

(12) PATENT
(19) AUSTRALIAN PATENT OFFICE

(11) Application No. AU 200020757 B2
(10) Patent No. 781771

(54) Title
Pivotable razor assembly and cartridge

(51) ⁶ International Patent Classification(s)
B26B 021/22 B26B 021/16

(21) Application No: 200020757 (22) Application Date: 2000.03.08

(30) Priority Data

(31) Number	(32) Date	(33) Country
09/295881	1999.04.21	US

(43) Publication Date : 2000.10.26
(43) Publication Journal Date : 2000.10.26
(44) Accepted Journal Date : 2005.06.09

(71) Applicant(s)
Warner-Lambert Company

(72) Inventor(s)
Paul D. Richard; Thomas A. Follo

(74) Agent/Attorney
Shelston IP, Level 21, 60 Margaret Street, SYDNEY NSW 2000

(56) Related Art
US 5199173
US 4275498
US 3935639

ABSTRACT OF THE DISCLOSURE

A razor cartridge (11) and assembly (10) is disclosed. The cartridge includes curved journals at opposing sides and is arranged for pivotable movement on an associated handle assembly.

11
10
11
10
11
10
11
10
11
10

AUSTRALIA

PATENTS ACT 1990

COMPLETE SPECIFICATION

FOR A STANDARD PATENT

ORIGINAL



Name of Applicant/s: Warner-Lambert Company

Actual Inventor/s: Paul D Richard and Thomas A Foilo

Address for Service: BALDWIN SHELSTON WATERS
60 MARGARET STREET
SYDNEY NSW 2000

Invention Title: 'PIVOTABLE RAZOR ASSEMBLY AND CARTRIDGE'

The following statement is a full description of this invention, including the best method of performing it known to me/us:-

File: 27414AUP00

PIVOTABLE RAZOR ASSEMBLY AND CARTRIDGE

FIELD OF THE INVENTION

The present invention relates to razor assemblies having pivotable cartridges. More particularly, the present invention relates to a razor assembly including
5 a pivotably mounted razor cartridge for use during shaving.

BACKGROUND OF THE INVENTION

Any discussion of the prior art throughout the specification should in no way be considered as an admission that such prior art is widely known or forms part of common general knowledge in the field.

10 In an effort to increase comfort and shaving efficiency, many shaving razor assembly designs having pivotable razor cartridges have been developed.

Notwithstanding these prior art designs, a need for pivotable razor assembly designs having improved features such as enhanced stability, smoothness in operation and the like continues to exist. It is an object of the present invention to overcome or ameliorate
15 at least one of the disadvantages of the prior art, or to provide a useful alternative.

SUMMARY OF THE INVENTION

According to a first aspect, the present invention provides a razor cartridge comprising:

- 20 first and second opposing end members;
- a frame connected between said first and second end members;
- at least one blade supported by said frame and extending between said first and second end members; and
- a curved journal secured to each of said first and second end members, and being adapted to facilitate pivotal connection of said cartridge to a handle assembly,
- 25 wherein each of said first and second end members include an inner surface facing said inner surface of the other one of said end members, said first and second end members also including an arcuate bottom surface, and
- wherein said curved journal of each end member extends inwardly from a corresponding one of said inner surfaces toward the other one of said end members.

Unless the context clearly requires otherwise, throughout the description and the claims, the words 'comprise', 'comprising', and the like are to be construed in an inclusive sense as opposed to an exclusive or exhaustive sense; that is to say, in the sense of "including, but not limited to".

5 According to a second aspect, the present invention provides a razor assembly comprising:

 a handle assembly; and

 a razor cartridge pivotally attached to said handle assembly, said razor cartridge including first and second opposing end members, a frame connected between
10 said first and second end members, at least one blade supported by said frame and extending between said first and second end members, and a curved journal secured to each of said first and second end members, said curved journals being pivotally connected to said handle assembly,

 wherein each of said first and second end members includes an inner
15 surface facing said inner surface of the other one of said end members, said first and second end members also including an arcuate bottom surface, and

 wherein said curved journal of each end member extends inwardly from a corresponding one of said inner surfaces toward the other one of said end members.

 Preferably the curved journals to be connected adjacent to the arcuate
20 bottom surface of their corresponding end member. The curved journals may be integral with their corresponding end members.

 The razor cartridge preferably includes a plurality of blades, and in a particularly preferred embodiment includes three blades.

 In another preferred embodiment, the first and second opposing end
25 members are integral with the frame, and are made of a polymeric material.

 According to a third aspect, the present invention provides a razor cartridge comprising:

 first and second opposing end members;

 a frame connected between said first and second end members;

30 at least one blade supported by said frame and extending between said first and second end members; and

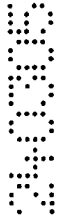

a curved journal formed on each of said first and second end members, and being adapted to facilitate pivotal connection of said cartridge to a handle assembly,

wherein each of said first and second end members include an inner surface facing said inner surface of the other one of said end members, said first and second end members also including an arcuate bottom surface, and

wherein said curved journal of each end member is arranged on a corresponding one of said inner surfaces of said end members, and extends substantially along the contour of the arcuate bottom surface of said end members.

According to another aspect, the present invention provides a razor assembly comprising:

a handle assembly; and

a razor cartridge pivotally attached to said handle assembly, said razor cartridge including first and second opposing end members, a frame connected between said first and second end members, at least one blade supported by said frame and extending between said first and second end members, and a curved journal formed on each of said first and second end members, said curved journals being pivotally connected to said handle assembly,

wherein each of said first and second end members include an inner surface facing said inner surface of the other one of said end members, said first and second end members also including an arcuate bottom surface, and

wherein said curved journal of each end member is arranged on a corresponding one of said inner surfaces, and extends substantially along the contour of said arcuate bottom surface.

In a preferred embodiment, the handle assembly comprises a handle and a clam shell connector structure arranged at an end of the handle. The clam shell connector structure may comprise a pair of arms, each having an arcuate bearing surface. In this preferred embodiment, the curved journals of the associated razor cartridge are adapted to rotate on corresponding ones of the arcuate bearing surfaces during use of the razor assembly.

Preferably, each of the arms of the clam shell connector structure includes a capture member which is arranged above and extends parallel with the arcuate bearing surface so as to define a curved passageway therebetween. In accordance with this



embodiment, the capture member and the arcuate bearing surface act in combination to capture a corresponding one of the curved journals therebetween thus pivotably securing the razor cartridge on the handle assembly.

At least one embodiment of the present invention overcomes various shortcomings in the prior art by providing a pivotable razor assembly including a cartridge having opposing ends with curved journals to facilitate pivotable connection of the cartridge to a handle assembly.

BRIEF DESCRIPTION OF THE DRAWINGS

The above features and advantages of the present invention will be more fully understood with reference to the following detailed description when taken in conjunction with the accompanying drawings.

FIG. 1 is a perspective view of a preferred embodiment of the present razor cartridge.

FIG. 2 is an exploded view of the razor cartridge shown in FIG. 1.

15
20
25
30

15
20
25
30

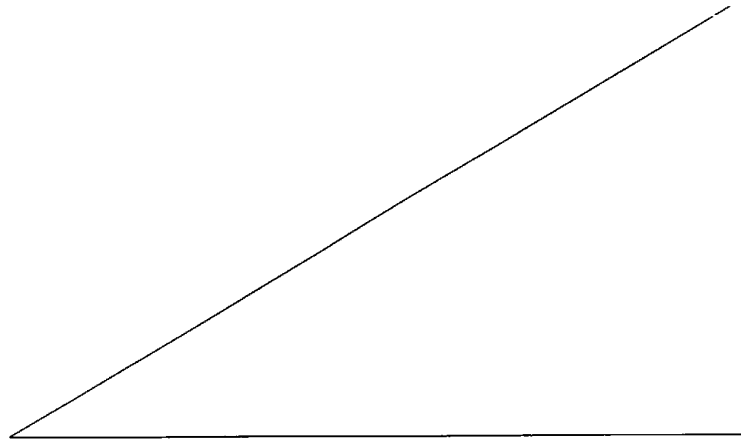

FIG. 3 is a bottom plan view of the razor cartridge shown in FIG. 1.

FIG. 4 is a rear view of the razor cartridge shown in FIG. 1.

FIG. 5 is a front view of the razor cartridge shown in FIG. 1.

FIG. 6 is a partially exploded perspective view of the present razor
5 cartridge and a portion of an associated handle.

FIG. 7 is a rear view of the razor cartridge illustrated in a mounted
position on a portion of an associated handle and shown in a flexed configuration.

FIG. 8 is a partial cross-sectional view of the razor cartridge shown
in FIG. 7.

10 FIG. 9 is a schematic side cross-sectional view of the razor assembly
of FIG. 1 shown in an at rest position.

FIG. 10 is a schematic side cross-sectional view of the razor assembly
of FIG. 9 shown in a pivoted configuration.

DETAILED DESCRIPTION OF THE PREFERRED EMBODIMENTS

15 With reference to FIGS. 1-10, the razor assembly 10 includes a
cartridge 11 and an associated handle assembly 94. The cartridge 11 has opposing
first and second end members 12 and 14 with a central section of a frame generally
designated 16 extending therebetween. In the preferred embodiment, the frame 16
is integral with the first and second opposing end members 12 and 14.

20 The frame 16 includes a plurality of vertically arranged ribs 18 as
shown in FIGS. 1, 3 and 4. The ribs may be equidistantly spaced from each other.
In alternate embodiments, the razor cartridge 11 may include one or more

vertically arranged ribs unevenly spaced from each other. In the preferred embodiment shown in FIGS. 1-10, ribs 18 provide support for razor blades 24, 36 and 48. Each of the ribs 18 include several longitudinal slots 20 in which the razor blades 24, 36 and 48 are arranged. The ribs have a rear face 22 as shown in FIGS.

5 4, 6 and 7.

Although the cartridge 11 shown in the preferred embodiment of FIG. 1 is a triple bladed cartridge including a seat blade 24, an intermediate blade 36 and a top blade 48, various aspects of the present invention may be used with a cartridge having more or less than three blades. The cartridge 11 includes a seat blade 24 having a cutting edge 26 and a rear edge 28.

10

The seat blade 24 includes a top surface 30 and a bottom surface 32.

As best shown in FIGS. 2 and 3, the seat blade 24 includes a plurality of large wash-through holes 34. In a preferred embodiment, each of the wash-through holes 34 is larger than the wash-through holes of prior art razor blades, and may encompass a total area of about 8.0-13.0 mm², and is more preferably about 12.3 mm². Of course, in alternate embodiments, the size of the wash-through holes 34 may vary outside of the preferred range. As shown in FIG. 2, the seat blade 24 is supported on the frame 16 in an aligned row of slots 20 of corresponding ribs 18.

15

The intermediate blade 36 also includes a cutting edge 38, a rear edge 40, a top surface 42 and a bottom surface 44. A plurality of wash-through holes 46 are arranged between the cutting and rear edges 38 and 40 so as to create a

20

passageway between the top and bottom surfaces 42-44. In a preferred embodiment, the wash-through holes 46 are also substantially larger than the wash-through holes of prior art razor blades and each may encompass a total area of about 5.0-7.0 mm², and is more preferably about 6.4 mm². As with the wash-through holes 34 of the seat blade, the size of the wash-through holes 34 may vary outside of the preferred range.

Another inventive feature of cartridge 11 is that the wash-through holes become progressively larger in the lower blades (e.g., the wash through holes 34 of the seat blade 24 are larger than the wash-through holes 46 of the intermediate blade 36). The particular geometric configuration and dimensions of wash-through holes 34 and 46 may vary substantially in alternate embodiments of the present invention. In certain embodiments, each of the wash-through holes may encompass a total area of at least 4 mm². However, in other embodiments, each of the wash-through holes in the various blades of cartridge 11 may encompass a total area of less than 4 mm².

The cartridge 11 also includes a top blade 48. Unlike the seat blade 24 and the intermediate blade 36, the top blade 48 need not include any wash-through holes. In a preferred embodiment, the top blade 48 is somewhat conventional in that it includes a cutting edge 50, a rear edge 52, a top surface 54 and a bottom surface 56. However, in alternate embodiments, the top blade 48 may also include wash-through holes.

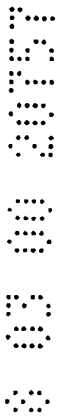

With respect to the triple-bladed construction of the cartridge 11, as shown in FIGS. 1, 9 and 10, the associated razor blades (i.e., seat blade 24, intermediate blade 36 and top blade 48) have a progressively shorter width (from their rear to front edges) in order to maintain desired span and exposure angles for shaving efficiency. However, the present invention is not limited to any particular blade dimension, configuration or geometry.

In the preferred embodiment described herein and shown in the accompanying drawings, the entire razor assembly 10 of the present invention is disposable. However, in alternate embodiments of the present invention, only the cartridge may be disposable.

The purpose of wash-through holes 34 and 46 is to facilitate removal of shaving cream and hair which may become lodged between blade surfaces during shaving. The cartridge 11 is generally designed to maximize rinsability (i.e., wash-through). While one aspect of the improved wash-through is due to the arrangement of the wash-through holes, another aspect relates to the straight wash-through as discussed below.

It is desirable to maximize the overlap of the wash-through holes 34 and 46. In the preferred embodiment where the wash-through holes 34 of the seat blade 24 are larger than the wash-through holes 46 of the intermediate blade 36, it is desirable to maximize the area of each wash-through hole 34 arranged directly above a corresponding area of one of the wash-through holes 46.

In a preferred embodiment, a relatively small distance may exist between the forward-most portion of wash-through holes 46 and the forward-most edge of intermediate blade 36. In other embodiments, the edge of intermediate blade 36 may be positioned so that it is actually arranged over a portion of the wash-through holes 46. While this arrangement is desirable from a wash-through perspective, it is difficult to achieve due to desired span and exposure, dimensions and angles.

It is also desirable for the side edges of each wash-through hole 34 to be arranged over a corresponding wash-through hole 46. However, in alternate embodiments, it is not necessary for the side edges of wash-through holes 34 to overlap corresponding wash-through holes 46.

Yet another significant aspect of the present invention is that the cartridge 11 facilitates a straight wash-through (i.e., from the front through the rear of the blades) of otherwise trapped shaving cream and hair in that it does not include a solid rear wall. Instead, the only rear wall sections of the cartridge 11 are those associated with first and second end members 12 and 14 and the rear faces 22 of the ribs 18. As illustrated in FIG. 4, the cartridge 11 includes relatively large open sections 66 through which deposited shaving cream and hair can be rinsed. This aspect of the present invention will also be discussed further below in connection with the operation thereof. In a preferred embodiment, the open sections 66 encompass a greater width than the solid wall sections, such as the width of rear faces 22 of rib 18. By way of example, each of the open sections 66,



may have a width of about 5.2 mm, while the width defined by each of the rear faces 22 of ribs 18 may be about 0.8 mm.

While the combination of the progressively larger wash-through holes and the straight wash-through feature facilitate the substantially improved wash-through characteristics of the cartridge 11, it should be appreciated that each of these features by themselves provide substantial advantages over prior art razor cartridges. Similarly, the relatively large wash-through hole size by itself is also an advantageous feature.

As illustrated in FIGS. 1, 2, 6 and 8, the first end member 12 includes an arcuate bottom surface 58 and a journalled end member 60 which extends inwardly toward the second side member 14. Similarly, the second side member 14 includes an arcuate bottom surface 62 and a journalled end member 64 which extends inwardly toward the first end member 12. The journalled end construction of cartridge 11 is an innovative feature which facilitates improved pivotability between the cartridge 11 and handle assembly 94. As shown in FIG. 5, the journalled end members 60 and 64 are tapered inwardly to allow the cartridge to pivot while it is in a flexed configuration.

In a preferred embodiment, the axis about which the cartridge 11 pivots extends between the cap 80 and guard bar 72, and is located on the shave plane (i.e., a tangent line between the cap and the guard bar). This arrangement optimizes blade contact with a person's skin during shaving.

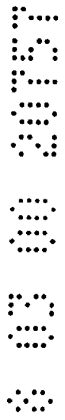

In a preferred embodiment, the curved journalled end members 60 and 64 are integral with their corresponding side members 12 and 14 and extend inwardly toward the other side member. Further, journalled end members 60 and 64 preferably follow the contour of associated arcuate bottom surfaces 58 and 62, respectively.

In addition to being mounted within the slots 20 of the ribs 18, the razor blades 24, 36 and 48 may be secured in assembled position within the cartridge frame 16 by posts (not shown) which extend through corresponding post holes 70 (FIG. 2) arranged near the rear section of all of the blades. As is known in the shaving razor field, the posts may be formed when the cartridge 11 including the blades are retained in a fixture. Outer holes 71 may have the same configuration as post holes 70, but are used to locate the razor blades 24, 36 and 48 during the manufacturing process.

The cartridge 11 is shown in FIGS. 1, 2 and 5 as including a guard bar 72. As is known to those skilled in the art, a guard bar is designed to be the first element of a safety razor to contact a person's skin during the shaving stroke. The guard bar 72 will control the manner in which the skin approaches the cutting edge 26 of the seat blade 24. The guard bar 72 may be a molded rubber strip 70 having a herring bone design or other desired design to facilitate the flow of skin over the guard bar segments during shaving.

In assembled position, the guard bar 72 is retained on a seat formed of segments 74 and 76, which have a unique structure. In particular, each of the



segments 74 are formed on a portion of a front horizontal beam 84 (described further below), while each of the segments 76 are formed on the forward-most portion of corresponding ribs 18.

The cartridge 11 also includes a cap 80, which forms a part of frame 5 16. The cap 80 is arranged above and in back of the top blade 48. As evident from FIGS. 1, 2 and 7, a shaving aid 82 may be arranged on cap 80. Various materials have been used in the prior art as shaving aids and may also be used in connection with the present invention. The term "shaving aid" as used herein, refers equally either to the active ingredient combined with a delivery system, such 10 as a water-insoluble microporous matrix structure or to the active ingredient alone. Previously suggested active ingredients include those in U.S. Patent No. 4,170,821 to Booth, which is hereby incorporated by reference. A shaving aid may comprise one of various combinations of the following:

A. A lubricating agent for reducing the frictional forces between 15 the razor and the skin, e.g., a microencapsulated silicone oil.

B. An agent which reduces the drag between the razor parts and the shaver's face, e.g., a polyethylene oxide in the range of molecular weights between 100,000 and 6 million; a non-ionic polyacrylamide; and/or a natural polysaccharide derived from plant materials such as "guar gum."

20 C. An agent which modifies the chemical structure of the hair to allow the razor blade to pass through the whiskers very easily, e.g., a depilatory agent is one example.

D. A cleaning agent which allows the whisker and skin debris to be washed more easily from the razor parts during shaving, e.g., a silicon polyethylene oxide block copolymer and detergent such as sodium lauryl sulphate.

E. A medicinal agent for killing bacteria, or repairing skin
5 damage and abrasions.

F. Cosmetic agent for softening, smoothing, conditioning or improving the skin.

G. A blood coagulant for the suppression of bleeding that occurs from nicks and cuts.

10 H. An astringent for constricting blood vessels thereby stemming the flow of bodily fluids such as lymph which may exude from skin which has been irritated during shaving.

Alternatively, the shaving aid may comprise one or more of these shaving aids disclosed in U.S. Patent Nos. 5,056,221; 4,044,120; and 5,095,619,
15 which are also incorporated herein by references.

Other activate ingredients may include various pigments, e.g., titanium dioxide, fragrances, aloe vera, flavoring agents, mineral oils, essential oils and other oils derived from plants. In addition to one or more active ingredients, the shaving aids of the present invention may also comprise other compounds or
20 blends of compounds such as water insoluble polymers such as polystyrene and polypropylene.

Although the particular type of shaving aid utilized is not a significant aspect of the present invention, it is inventive that in a preferred embodiment, the razor cartridge 11 is constructed and arranged to flex through an imaginary plane which extends through the shaving aid 82. Such flexing of the razor cartridge 11 is shown in FIGS. 7 and 8. When the razor cartridge 11 flexes, each of the razor blades 24, 36 and 48 bend from their rest position, where they have a substantially planar configuration to a configuration where the top surfaces thereof obtain a concave configuration. However, it should also be appreciated that the razor cartridge 11 may also flex so that the blades obtain a convex configuration with respect to the top surfaces thereof. Such flexing may be desirable in, for example, a women's razor.

Further, when the razor cartridge 11 flexes, it is preferable for the intermediate and seat blades 36 and 24 to slide longitudinally relative to each other within slots 20. This arrangement further facilitates flexibility of the cartridge and allows the vertical spacing between the blades to remain substantially constant during flexing.

Another significant aspect of the cartridge 11 is that it includes horizontally extending beams, such as front beam 84 and rear beam 88 which facilitate the flexible nature of the cartridge 11. In particular, the front horizontal beam 84 comprises a plurality of segments 86 which collectively form a saw-tooth pattern. The cartridge 11 also includes a rear horizontally extending beam 88 that comprises separate segments 90 which have an appearance substantially similar to

the collective appearance of the segments of the front horizontal beam 84. The segments 86 and 90 are arranged between respective ribs 18 on the cartridge frame 16. The segments 86 of front beam 84 are formed in conjunction with guard bar segments 74, as best illustrated in FIG. 3.

5 The structure of the front beam 84 and rear beam 88 are also inventive in various ways including their generally horizontally extending structure. In addition, the connection between the segments 86 of the front horizontally extending beam 84 and guard bar segments 74 is inventive.

10 The front beam 84 and rear beam 88 are generally constructed and arranged to flex along with cartridge frame 16 when an appropriate force is encountered during shaving. Upon flexing, horizontal beams 84 and 88 are placed under tension and thus bias the cartridge frame 16 to return to its at-rest position where the blades 24, 36 and 48 are in a substantially planar configuration. Thus, one function of horizontal beams 84 and 88 is to bias the razor cartridge 11 to
15 return to its at-rest position from a flexed position.

 The combination of front beam 84 and rear beam 88 is also beneficial in that it provides structural integrity to the cartridge 11. In particular, such combination helps prevent the cartridge 11 from twisting when shaving forces are applied.

20 Yet another significant aspect of the present invention is that the razor assembly 10 includes a cartridge 11 which is both flexible and pivotable. The center rib 18 includes a downwardly extending bearing surface 92 which, is used,



in a preferred embodiment to facilitate pivoting of the cartridge 11 as discussed below.

As shown in FIG. 6, the center rib 18 also includes a notch 97 to provide clearance from a contact surface 106 of a spring arm 104 to allow the cartridge 11 to flex where the top surface of the blades obtain a concave configuration. The notch 97 includes an upper surface that acts as a stop with respect to the contact surface 106 so that the cartridge 11 will not overflex.

The razor assembly 10 also includes a handle assembly 94 on which the cartridge 11 is pivotably mounted. In particular, the handle assembly 94 includes first and second side curved journal members 96 and 100, respectively. This aspect of the present invention is shown in FIGS. 1 and 6-10. The first side curved journal member 96 includes capture member 98 while the second side curved journal member 100 includes capture member 102. As evident from FIG. 8, the cartridge 11 is mounted on the handle assembly 94 by securing the arcuate journalled end members 60 and 64 on corresponding first and second curved journal members 96 and 100. More particularly, the curved journalled end members 60 and 64 of cartridge 11 are arranged within the curved passageway formed between a corresponding one of the curved journal members 96 and 100 and their respective capture members 98 and 102. This mounting structure may be considered a "clam shell" pivot arrangement formed by the cooperating curved journal members 96 and 100 with the curved journalled end members 60 and 64 of the cartridge 11.



As schematically illustrated in FIG. 9, the cartridge 11 of razor assembly 10 is initially biased to its rear-most position. As used herein, this rearward biased cartridge arrangement is also referred to as a "unidirectional" pivot arrangement. Such arrangement has certain advantages such as the elimination of deadband (i.e., where the cartridge is not under a spring-loaded or other bias force). The existence of deadband is undesirable because it may result in vibration of the cartridge 11 during handling of the razor assembly 10. However, it should be appreciated that the particular pivot arrangement may be modified in alternate embodiments of the present invention. For example, a forward biased (also unidirectional) or center biased pivot arrangement (bi-directional) may be used in place of the rearward biased pivot arrangement.

In the rearward biased embodiment schematically shown in FIG. 10, an upwardly extending spring arm 104 (best shown in FIGS. 6 and 7) extends from an end of the handle assembly 94. The spring arm 104 includes contact surface 106 at a top portion thereof which engages the downwardly extending bearing surface 92 from the center rib 18 of the cartridge 11. This structure urges the cartridge 11 to pivot to its rear-most position when the razor assembly 10 is not in use.

The contact surface 106 of spring arm 104 includes two bosses that provide a groove through a central portion of contact surface 106. The groove (unnumbered) receives the center rib 18 of the cartridge 11. When the cartridge 11 flexes during shaving, the journalled end members 60 and 64 open up as illustrated

in FIG. 7. The groove between the bosses maintain the cartridge 11 in a centered position.

The spring arm 104 has a substantially elongated triangular shape which provides for a desired degree of stiffness to help prevent side-to-side travel of cartridge 11. As best shown in FIGS. 6 and 7, a central portion of the triangular shaped spring arm 104 is cut away to provide the desired spring effect and to allow the center rib 18 of the cartridge 11 to rotate during flexing and/or pivoting of the cartridge 11.

As also illustrated in FIGS. 6 and 7, in a preferred embodiment, an integral "pivot frame" 103 is provided. The pivot frame 103 includes the spring arm 104 and the first and second curved journal members 96 and 100. The integral nature of the pivot frame 103 provides for manufacturing and structural advantages.

In operation, various advantages of the structural features of razor assembly 10 become evident. When the razor assembly 10 is in its at rest position, the cartridge 11 is neither flexed nor pivoted forwardly. However, during shaving, the cartridge 11 is designed to both pivot on the handle assembly 94 and to flex, if necessary. FIGS. 1 and 9 illustrate the razor assembly 10 when arranged in its at rest position prior to shaving. However, when a force is exerted on the razor cartridge 11 during shaving, the cartridge 11 may pivot forwardly (as shown in FIG. 10) on the clam-shell connector structure formed by the first and second bearing surfaces 96 and 100, and curved capture members 98 and 102 of the handle



assembly 94 in combination with the curved journalled end members 60 and 64 of the cartridge 11.

As discussed above, the cartridge 11 is constructed and arranged to flex through an imaginary plane which extends through the shaving aid 82. Such arrangement is designed to extend the life of the shaving aid 82 by minimizing cracking and wear thereof.

As is common with any multiple bladed razor, shaving cream and hair will become deposited between the surfaces of blades 24, 36 and 48 of cartridge 11 during use. It is desirable to remove such deposited shaving cream and hair as quickly and easily as possible. Efficient removal of deposited shaving cream and hair is accomplished through the use of several inventive features including the relatively large wash-through holes 34 and 46 of seat blade 24 and intermediate blade 36, respectively; the progressively larger nature of the wash-through holes 34 on seat blade 24 as compared to the wash-through holes 46 of intermediate blade 36; and the straight wash-through arrangement obtained by the open sections 66 at the open rear of cartridge 11. In this regard, when the cartridge 11 is rinsed after a shaving stroke, the water will force deposited shaving cream and hair straight through the cartridge 11 along the top and bottom surfaces of the associated blades and out of the rear sections 66. Removal of the unwanted shaving cream and hair will also be facilitated by wash-through holes 34 and 46.

It should be appreciated that although preferred embodiments of the present invention are discussed above, those of skill in the art are encouraged to

modify the disclosed structure and arrangement of various features of the present razor cartridge and assembly without departing from the scope of the present invention, which is defined by the claims set forth below.

1
2
3
4
5
6
7
8
9
10

THE CLAIMS DEFINING THE INVENTION ARE AS FOLLOWS:-

1. A razor cartridge comprising:
first and second opposing end members;
5 a frame connected between said first and second end members;
at least one blade supported by said frame and extending between said
first and second end members; and
a curved journal secured to each of said first and second end members,
and being adapted to facilitate pivotal connection of said cartridge to a handle assembly,
10 wherein each of said first and second end members include an inner
surface facing said inner surface of the other one of said end members, said first and
second end members also including an arcuate bottom surface, and
wherein said curved journal of each end member extends inwardly from a
corresponding one of said inner surfaces toward the other one of said end members.
15
2. The razor cartridge of claim 1 wherein said curved journal of each
end member extends substantially along the contour of the arcuate bottom surface of a
corresponding one of said end members.
3. The razor cartridge of claim 2 wherein said curved journals are
connected adjacent to said arcuate bottom surface of corresponding ones of said end
20 members.
4. The razor cartridge of claim 1 wherein said curved journals are
integral with corresponding ones of said end members.
5. The razor cartridge of claim 1 wherein said at least one blade
comprises a plurality of blades.
- 25 6. The razor cartridge of claim 1 wherein said curved journals are
tapered inwardly.
7. The razor cartridge of claim 1 wherein said first and second
opposing end members are integral with said frame.
8. A razor assembly comprising:
30 a handle assembly; and
a razor cartridge pivotally attached to said handle assembly, said razor
cartridge including first and second opposing end members, a frame connected between

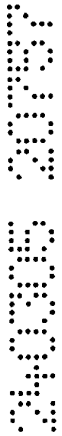

said first and second end members, at least one blade supported by said frame and extending between said first and second end members, and a curved journal secured to each of said first and second end members, said curved journals being pivotally connected to said handle assembly,

5 wherein each of said first and second end members includes an inner surface facing said inner surface of the other one of said end members, said first and second end members also including an arcuate bottom surface, and

 wherein said curved journal of each end member extends inwardly from a corresponding one of said inner surfaces toward the other one of said end members.

10 9. The razor assembly of claim 8 wherein said curved journal of each end member extends substantially along the contour of said arcuate bottom surface of a corresponding one of said end members.

 10. The razor assembly of claim 9 wherein said curved journals are connected adjacent to said arcuate bottom surface of corresponding ones of said end members.

 11. The razor assembly of claim 8 wherein said curved journals are integral with corresponding ones of said end members.

 12. The razor assembly of claim 8 wherein said at least one blade comprises a plurality of blades.

20 13. The razor assembly of claim 8 wherein said curved journals are tapered inwardly.

 14. The razor assembly of claim 8 wherein said handle assembly comprises a handle and a clam shell connector structure arranged at an end of said handle.

25 15. The razor assembly of claim 14 wherein said clam shell connector structure comprises a pair of arms each having an arcuate bearing surface, each of said curved journals being adapted to rotate on corresponding ones of said arcuate bearing surfaces during use of said razor assembly.

 16. The razor assembly of claim 15 wherein each of said pair of arms
30 include a capture member, at least a portion of said capture members being arranged above said arcuate bearing surface, said capture member and said arcuate bearing surface

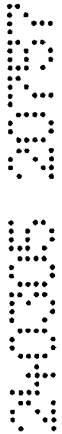

acting in combination to capture a corresponding one of said curved journals therebetween thus securing said razor cartridge on said handle assembly.

17. A razor cartridge comprising:
first and second opposing end members;
5 a frame connected between said first and second end members;
at least one blade supported by said frame and extending between said first and second end members; and

a curved journal formed on each of said first and second end members, and being adapted to facilitate pivotal connection of said cartridge to a handle assembly,
10 wherein each of said first and second end members include an inner surface facing said inner surface of the other one of said end members, said first and second end members also including an arcuate bottom surface, and

wherein said curved journal of each end member is arranged on a corresponding one of said inner surfaces of said end members, and extends substantially
15 along the contour of the arcuate bottom surface of said end members.

18. The razor cartridge of claim 17 wherein said curved journals are integral with a corresponding one of said end members.

19. The razor cartridge of claim 17 wherein said at least one blade comprises a plurality of blades.

20. The razor cartridge of claim 17 wherein said curved journals are tapered inwardly.

21. A razor assembly comprising:
a handle assembly; and

25 a razor cartridge pivotally attached to said handle assembly, said razor cartridge including first and second opposing end members, a frame connected between said first and second end members, at least one blade supported by said frame and extending between said first and second end members, and a curved journal formed on each of said first and second end members, said curved journals being pivotally connected to said handle assembly,

30 wherein each of said first and second end members include an inner surface facing said inner surface of the other one of said end members, said first and second end members also including an arcuate bottom surface, and

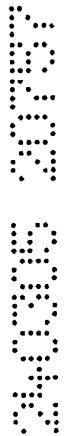

wherein said curved journal of each end member is arranged on a corresponding one of said inner surfaces, and extends substantially along the contour of said arcuate bottom surface.

22. The razor assembly of claim 21 wherein said first and second end members are integral with said frame.

23. The razor assembly of claim 21 wherein said at least one blade comprises a plurality of blades.

24. The razor assembly of claim 21 wherein said curved journals are tapered inwardly.

25. The razor assembly of claim 21 wherein said handle assembly comprises a handle and a clam shell connector structure arranged at an end of said handle.

26. The razor assembly of claim 25 wherein said clam shell connector structure comprises a pair of arms each having an arcuate bearing surface, each of said curved journals being adapted to rotate on corresponding ones of said arcuate bearing surfaces during use of said razor assembly.

27. The razor assembly of claim 26 wherein each of said pair of arms include a capture member, at least a portion of said capture member being arranged above said arcuate bearing surface, said capture member and said arcuate bearing surface acting in combination to capture a corresponding one of said curved journals therebetween thus securing said razor cartridge on said handle assembly.

28. A razor cartridge substantially as herein described with reference to any one of the embodiments of the invention illustrated in the accompanying drawings.

29. A razor assembly substantially as herein described with reference to any one of the embodiments of the invention illustrated in the accompanying drawings.

DATED this 24th Day of March, 2005

Shelston IP
Attorneys for: WARNER-LAMBERT COMPANY

FIG. 1

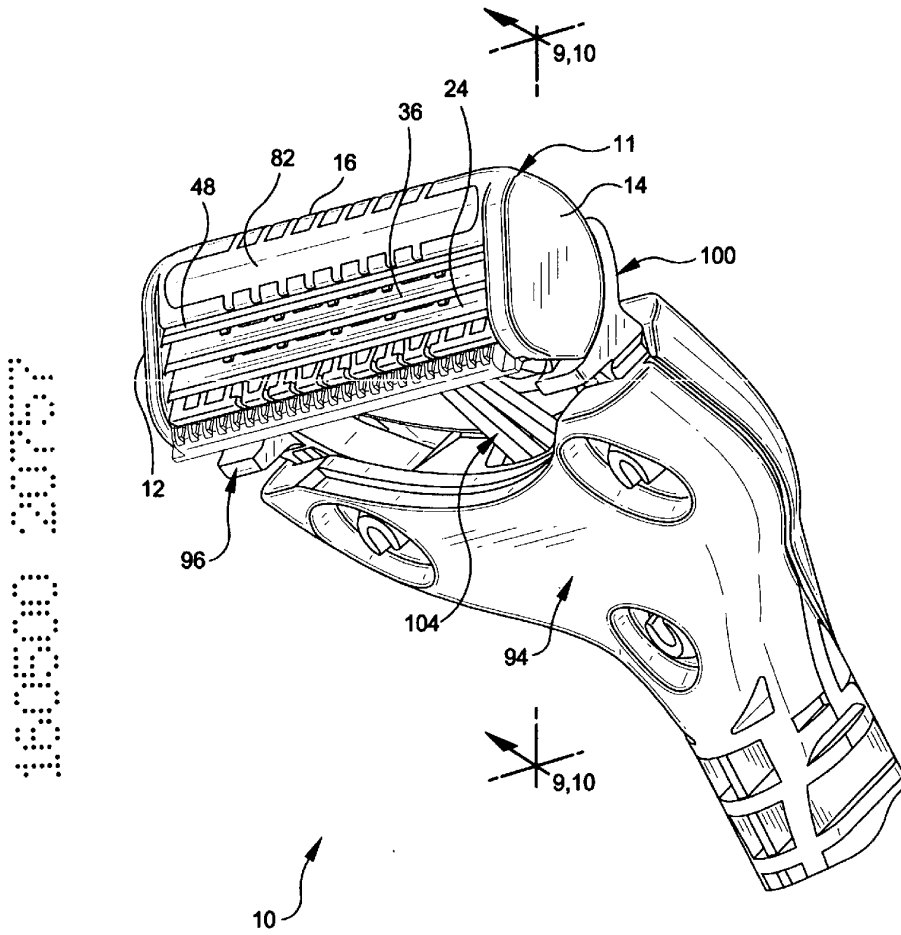

FOR OFFICE USE ONLY

16000 3075

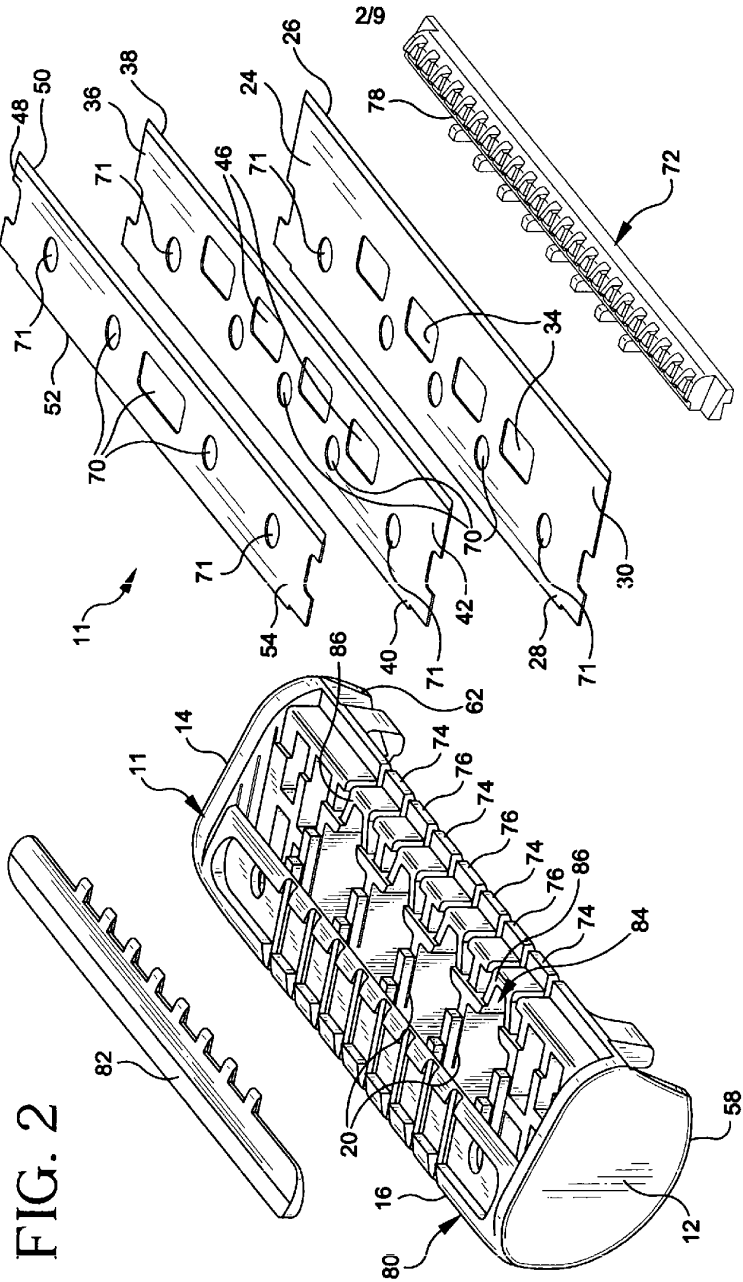

16000 3073

FIG. 3

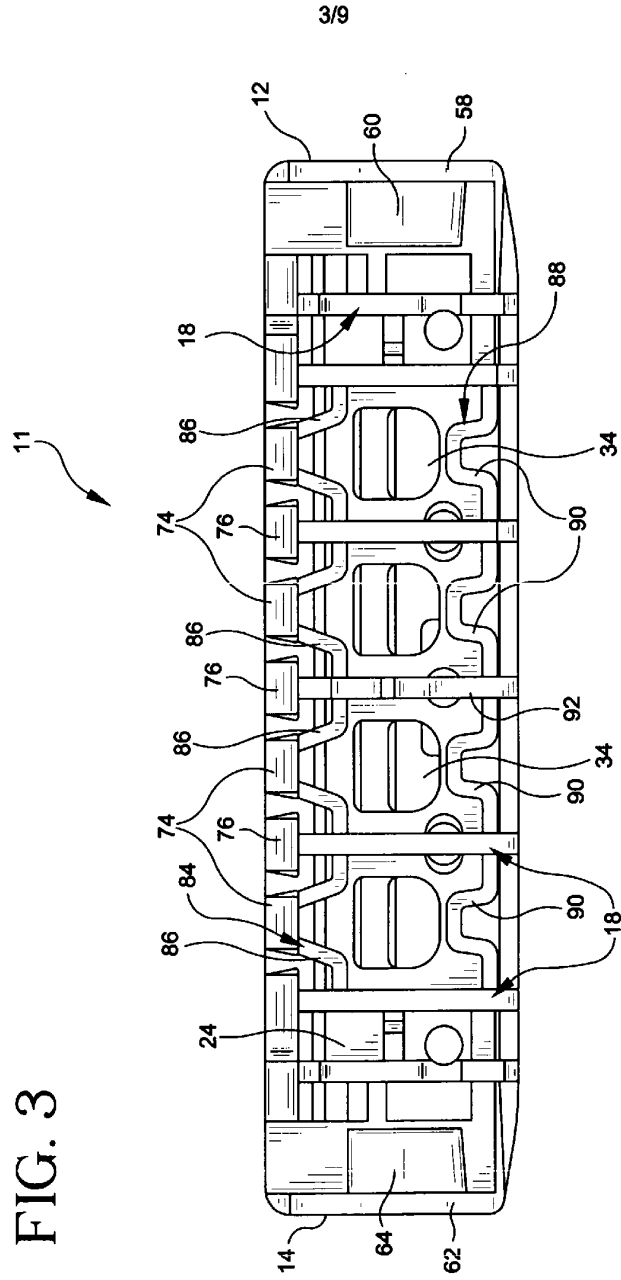

16500 3075

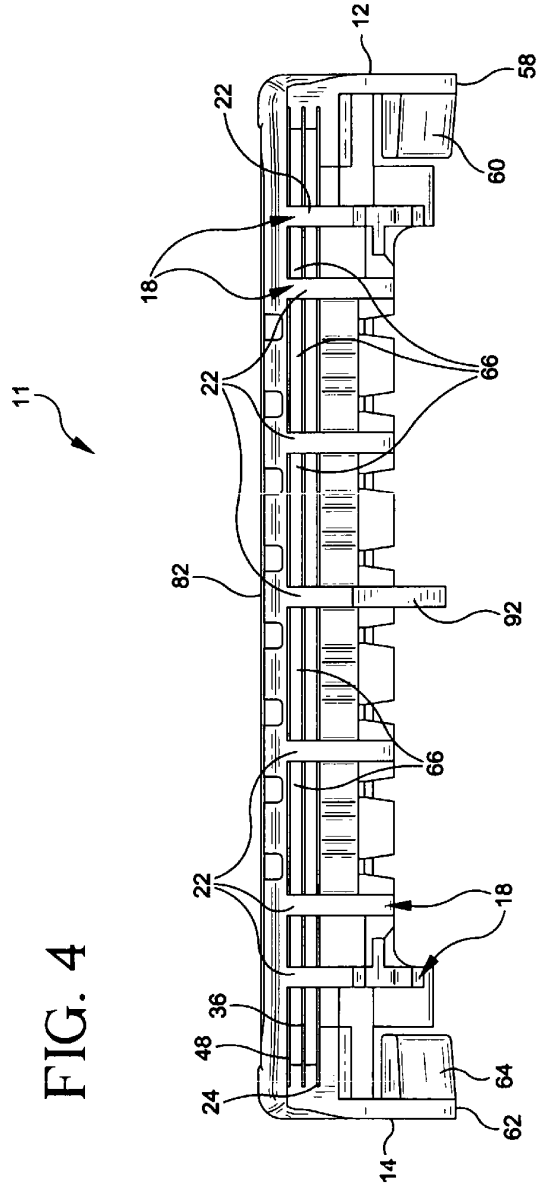
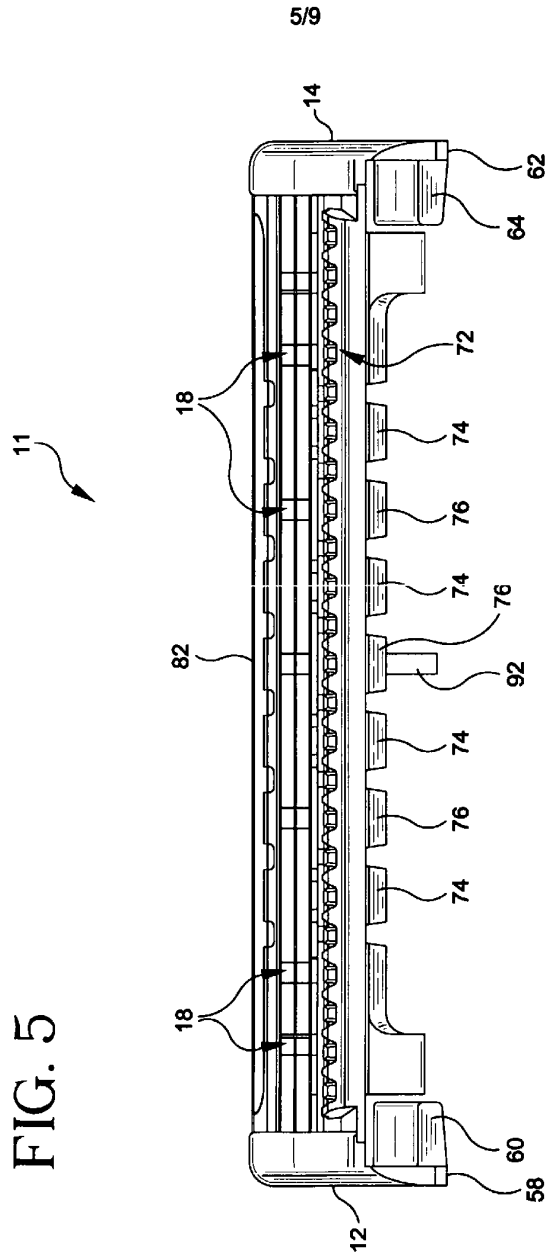

FIG. 4

10000 20757

FIG. 5



15000 20757

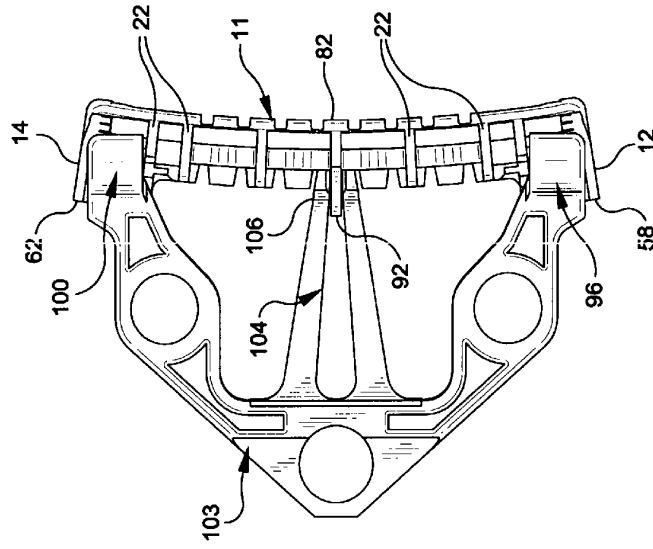

FIG. 7

16000 0005

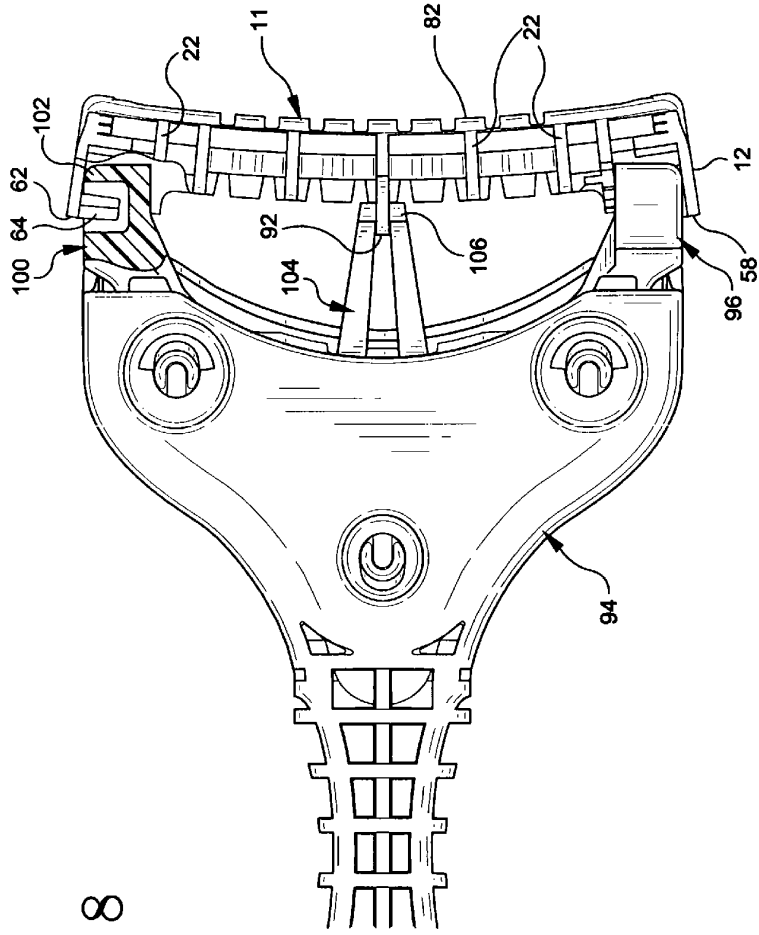

FIG. 8

FIG. 9

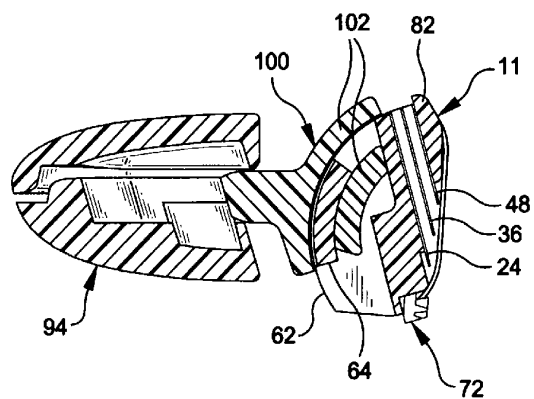
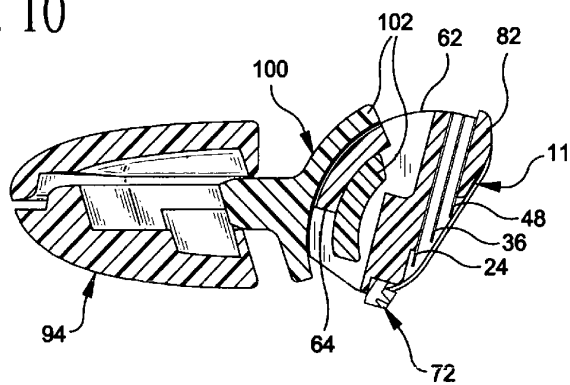

FIG. 10



100
102
82
11
48
36
24
94
62
64
72