



US00D820222S

(12) **United States Design Patent**
Clymer et al.

(10) **Patent No.:** **US D820,222 S**

(45) **Date of Patent:** **** *Jun. 12, 2018**

(54) **LOAD CONTROL DEVICE**

FOREIGN PATENT DOCUMENTS

(71) Applicant: **Lutron Electronics Co., Inc.**,
Coopersburg, PA (US)

EM 000646047-0013 6/2006
ES D0503833-0003 9/2006

(72) Inventors: **Erica L. Clymer**, Northampton, PA
(US); **Brad Michael Kreschollek**,
Bethlehem, PA (US); **Matthew Philip
McDonald**, Phoenixville, PA (US);
Elliot G. Jacoby, Glenside, PA (US);
Joel S. Spira, Coopersburg, PA (US)

OTHER PUBLICATIONS

Design No. ESD0503833-0003, www.tmdn.org/tmdsviw-web/
welcome, © 2007-2012, 3 pages, application date Sep. 27, 2006;
accessed Jul. 1, 2014.

(Continued)

(73) Assignee: **LUTRON ELECTRONICS CO.,
INC.**, Coopersburg, PA (US)

Primary Examiner — Selina Sikder

(74) *Attorney, Agent, or Firm* — Condo Roccia Koptiw
LLP

(*) Notice: This patent is subject to a terminal dis-
claimer.

(57) **CLAIM**

The ornamental design for a load control device, as shown
and described.

(**) Term: **15 Years**

(21) Appl. No.: **29/578,779**

(22) Filed: **Sep. 23, 2016**

DESCRIPTION

This application is also related to U.S. patent application Ser.
No. 29/449,250, filed on Mar. 14, 2013 and entitled "Load
Control Device," U.S. patent application Ser. No. 29/449,
237, filed on Mar. 14, 2013 and entitled "Load Control
Device," U.S. patent application Ser. No. 29/449,242, filed
on Mar. 14, 2013 and entitled "Load Control Device," U.S.
patent application Ser. No. 29/449,257, filed on Mar. 14,
2013 and entitled "Load Control Device," and U.S. patent
application Ser. No. 29/449,263, filed on Mar. 14, 2013 and
entitled "Load Control Device."

FIG. 1 is a perspective view of an embodiment of a load
control device embodying our new design;
FIG. 2 is a front view of the load control device of FIG. 1;
FIG. 3 is a first side view of the load control device of FIG.
1;
FIG. 4 is a second side view of the load control device of
FIG. 1;
FIG. 5 is a top view of the load control device of FIG. 1; and,
FIG. 6 is a bottom view of the load control device of FIG.
1.

The broken lines in the drawings are included for the
purpose of illustrating an environment of the article and

(Continued)

Related U.S. Application Data

(63) Continuation of application No. 29/481,133, filed on
Jan. 31, 2014, now Pat. No. Des. 769,830, which is a
(Continued)

(51) **LOC (11) Cl.** **14-03**

(52) **U.S. Cl.**
USPC **D13/168**

(58) **Field of Classification Search**
USPC D13/168, 174; D14/341, 218, 250
(Continued)

(56) **References Cited**

U.S. PATENT DOCUMENTS

3,779,851 A 12/1973 Hertz
D254,849 S 4/1980 Matsuda
(Continued)

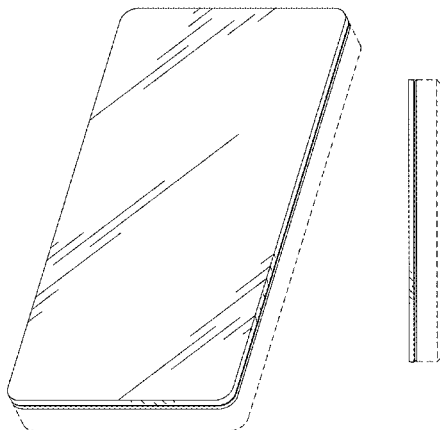

form no part of the claimed design. Additionally, the rear view forms no part of the claimed design.

1 Claim, 3 Drawing Sheets

Related U.S. Application Data

continuation of application No. 29/449,232, filed on Mar. 14, 2013, now Pat. No. Des. 718,723.

(58) **Field of Classification Search**

CPC H03J 1/0025; H03J 9/00; H03J 9/02; H03J 9/04; H03J 9/06; H01H 2009/187; H01H 9/02; H01H 9/0214; H01H 9/0242; H01H 9/18; H05B 37/02; H05B 37/0272; H05B 39/088; G08C 17/00; G08C 17/02; G08C 19/28; G08C 23/02; G08C 23/04; H04M 1/0262; H04M 1/0266; H05K 5/0017; G02F 1/1333; G06F 1/1626; G06F 3/0488; H01M 2/1061

See application file for complete search history.

(56) **References Cited**

U.S. PATENT DOCUMENTS

4,269,318 A 5/1981 Levitt et al.
 4,532,395 A 7/1985 Zukowski
 4,718,866 A 1/1988 Yamaguchi
 4,783,581 A 11/1988 Flowers et al.
 4,803,380 A 2/1989 Jacoby et al.
 5,153,816 A 10/1992 Griffin
 5,196,782 A 3/1993 D'Aleo et al.
 D336,744 S 6/1993 Kahn et al.
 D337,569 S 7/1993 Kando
 5,248,919 A 9/1993 Hanna et al.
 D353,798 S 12/1994 Bryde et al.
 5,621,283 A 4/1997 Watson et al.
 5,637,930 A 6/1997 Rowen et al.
 5,837,937 A 11/1998 Reese et al.
 5,876,106 A 3/1999 Kordecki
 6,026,605 A 2/2000 Tippett
 6,120,262 A 9/2000 McDonough et al.
 D439,220 S 3/2001 Mayo et al.
 6,380,696 B1 4/2002 Sembhi et al.
 6,507,377 B1 1/2003 Jung
 D487,429 S 3/2004 Bennett et al.
 D496,003 S 9/2004 Spira
 D496,335 S 9/2004 Spira
 D500,037 S 12/2004 Ozolins et al.
 6,835,906 B2 12/2004 Okamoto et al.
 D504,889 S 5/2005 Andre et al.
 6,963,040 B1 11/2005 Urman
 6,992,612 B2 1/2006 Pessina et al.
 D514,590 S 2/2006 Naruki
 D515,448 S 2/2006 Nelson et al.
 D516,040 S 2/2006 Moye
 D527,711 S 9/2006 Spira et al.
 D529,448 S 10/2006 de Melo et al.
 7,142,932 B2 11/2006 Spira et al.
 D537,046 S 2/2007 Blair et al.
 D543,951 S 6/2007 Blair et al.
 7,250,579 B2 7/2007 Ahlers et al.
 D557,259 S 12/2007 Hirsch
 D557,666 S 12/2007 Schroter
 D558,757 S 1/2008 Andre et al.
 D567,768 S 4/2008 Lee et al.
 7,365,282 B2 4/2008 Altonen et al.
 D583,337 S 12/2008 Ni
 D592,607 S 5/2009 Felegy, Jr. et al.
 7,547,119 B2 6/2009 Kuwana et al.
 7,579,717 B2 8/2009 Blair et al.

D602,446 S 10/2009 Felegy, Jr. et al.
 D602,486 S 10/2009 Andre et al.
 D606,030 S 12/2009 Felegy, Jr. et al.
 D614,146 S 4/2010 Felegy, Jr. et al.
 D619,544 S 6/2010 Petrillo et al.
 D619,106 S 7/2010 Felegy, Jr. et al.
 D619,972 S 7/2010 Felegy, Jr. et al.
 D622,719 S 8/2010 Andre et al.
 D624,880 S 10/2010 Felegy, Jr. et al.
 D626,092 S 10/2010 Clymer et al.
 D627,308 S 11/2010 Snyder et al.
 D627,309 S 11/2010 Snyder et al.
 D627,343 S 11/2010 Andre et al.
 7,869,206 B2 1/2011 Dabov et al.
 D631,854 S 2/2011 Blair et al.
 D631,855 S 2/2011 Blair et al.
 D633,874 S 3/2011 Feldstein et al.
 D636,347 S 4/2011 Felegy, Jr. et al.
 D638,375 S 5/2011 Clymer et al.
 D638,835 S 5/2011 Akana et al.
 D640,209 S 6/2011 Felegy, Jr. et al.
 D640,219 S 6/2011 Sutherland et al.
 D640,641 S 6/2011 Felegy, Jr. et al.
 D645,001 S 9/2011 Margolin et al.
 8,027,157 B2 9/2011 Shen et al.
 D646,232 S 10/2011 Felegy, Jr. et al.
 D647,066 S 10/2011 Jacoby et al.
 D647,882 S 11/2011 Kim et al.
 D649,123 S 11/2011 Jacoby et al.
 8,116,073 B2 2/2012 Hung et al.
 D655,254 S 3/2012 Jacoby et al.
 D660,809 S 5/2012 Kern Koskela et al.
 8,237,601 B2 8/2012 Dunbar et al.
 D666,978 S 9/2012 Felegy, Jr. et al.
 D669,038 S 10/2012 Felegy, Jr. et al.
 D672,344 S 12/2012 Li
 8,330,639 B2 12/2012 Wong et al.
 D673,510 S 1/2013 Felegy, Jr. et al.
 D678,261 S 3/2013 Akana et al.
 D688,214 S 8/2013 Ducret et al.
 8,525,372 B2 9/2013 Huang
 D694,197 S 11/2013 Felegy, Jr. et al.
 D694,716 S 12/2013 Felegy et al.
 D704,151 S 5/2014 Jacoby et al.
 D704,153 S 5/2014 Altonen et al.
 D705,779 S 5/2014 Akana et al.
 D712,363 S 9/2014 Clymer et al.
 D713,361 S 9/2014 Spira
 D718,723 S 12/2014 Clymer et al.
 D719,108 S * 12/2014 Clymer D13/168
 D769,830 S * 10/2016 Clymer D13/168
 D770,395 S * 11/2016 Clymer D13/168
 2005/0072661 A1 4/2005 Katagiri
 2006/0281501 A1 12/2006 Zuo et al.
 2007/0096903 A1 5/2007 Hibshman et al.
 2008/0024462 A1 1/2008 Kim et al.
 2008/0123271 A1 5/2008 Shu
 2009/0049773 A1 2/2009 Zadesky et al.
 2009/0245565 A1 10/2009 Mittleman et al.
 2010/0110013 A1 5/2010 Li et al.
 2011/0075065 A1 3/2011 Ozolins et al.
 2011/0151945 A1 6/2011 Jiang et al.
 2011/0188179 A1 8/2011 Myers et al.
 2011/0279300 A1 11/2011 Mosebrook
 2012/0013450 A1 1/2012 Lee et al.
 2012/0050988 A1 3/2012 Rothkopf et al.
 2012/0092812 A1 4/2012 Lewis et al.
 2014/0300567 A1 10/2014 Inata et al.

OTHER PUBLICATIONS

Design No. EM000646047-0013, www.tmdn.org/tmdsview-web/welcome, © 2007-2012, 6 pages, application date Dec. 7, 2006; accessed Jul. 1, 2014.

* cited by examiner

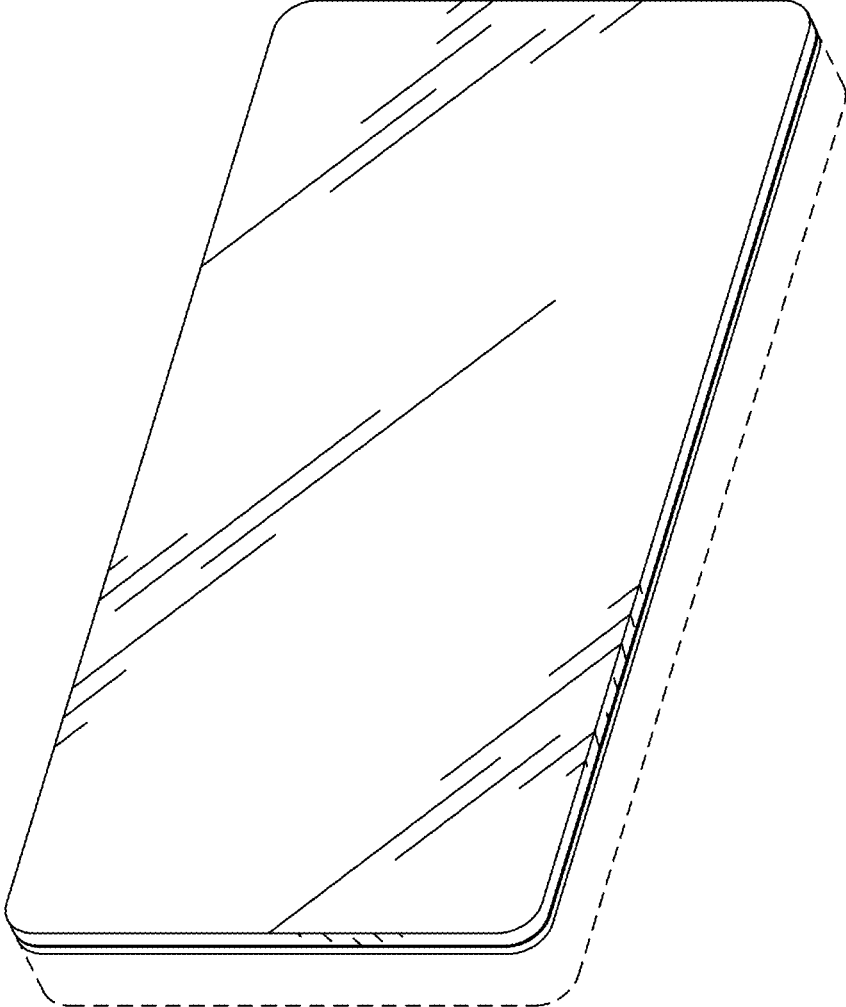

FIG. 1

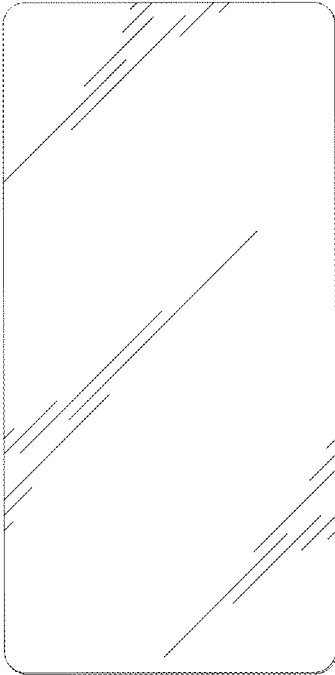

FIG. 2



FIG. 3

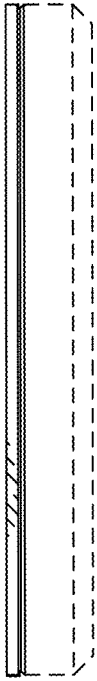

FIG. 4



FIG. 5

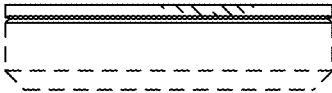

FIG. 6