

(19) World Intellectual Property Organization
International Bureau



(43) International Publication Date
30 November 2006 (30.11.2006)

PCT

(10) International Publication Number
WO 2006/127593 A2

- (51) International Patent Classification: **Not classified**
- (21) International Application Number:
PCT/US2006/019727
- (22) International Filing Date: 23 May 2006 (23.05.2006)
- (25) Filing Language: English
- (26) Publication Language: English
- (30) Priority Data:
60/683,635 23 May 2005 (23.05.2005) US
- (71) Applicant (for all designated States except US):
SYNECOR, LLC [US/US]; 3908 Patriot Drive, Suite 170, Durham, NC 27703 (US).
- (72) Inventors; and
- (75) Inventors/Applicants (for US only): **STACK, Richard, S.** [US/US]; 106 Alder Place, Chapel Hill, NC 27514 (US). **BALBIERZ, Daniel, J.** [US/US]; 973 Cambridge Road, Redwood City, CA 94601 (US). **ATHAS, William, L.** [US/US]; 3901 King Charles Road, Durham, NC 27707 (US). **LUNSFORD, John** [US/US]; 123 Leslie Drive, San Carlos, CA 94070 (US). **VAN BLADEL, Kevin**

[US/US]; 1425 Murdell Lane, Livermore, CA 94550 (US). **MOHAN, Ashik** [US/US]; 115 Constitution Drive, Suite 3, Menlo Park, CA 94025 (US). **CREWS, Sam** [US/US]; 115 Constitution Drive, Suite 3, Menlo Park, CA 94025 (US). **VEMURA, Shuji** [US/US]; 115 Constitution Drive, Suite 3, Menlo Park, CA 94025 (US). **HAWES, Rob** [US/US]; 115 Constitution Drive, Suite 3, Menlo Park, CA 94025 (US).

(74) Agents: **FROST, Kathleen, A.** et al.; **STALLMAN & POLLOCK LLP**, 353 Sacramento Street, Suite 2200, San Francisco, CA 94111 (US).

(81) Designated States (unless otherwise indicated, for every kind of national protection available): AE, AG, AL, AM, AT, AU, AZ, BA, BB, BG, BR, BW, BY, BZ, CA, CH, CN, CO, CR, CU, CZ, DE, DK, DM, DZ, EC, EE, EG, ES, FI, GB, GD, GE, GH, GM, HR, HU, ID, IL, IN, IS, JP, KE, KG, KM, KN, KP, KR, KZ, LC, LK, LR, LS, LT, LU, LV, LY, MA, MD, MG, MK, MN, MW, MX, MZ, NA, NG, NI, NO, NZ, OM, PG, PH, PL, PT, RO, RU, SC, SD, SE, SG, SK, SL, SM, SY, TJ, TM, TN, TR, TT, TZ, UA, UG, US, UZ, VC, VN, YU, ZA, ZM, ZW.

[Continued on next page]

(54) Title: RESTRICTIVE AND/OR OBSTRUCTIVE IMPLANT SYSTEM FOR INDUCING WEIGHT LOSS

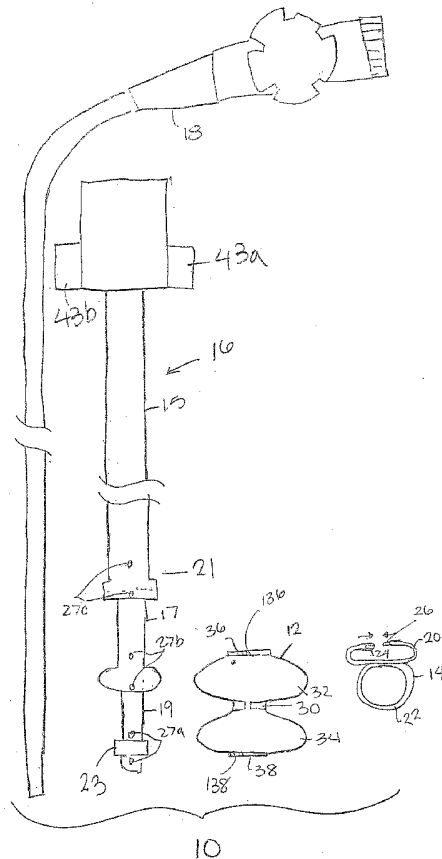

(57) Abstract: The present application describes an implant system useable for positioning an implant device such as a device useful for restricting passage of ingested food into the stomach. In one embodiment, the disclosed system includes a plurality of anchors that may be coupled to tissue within the stomach, or to a tissue tunnel formed by plicating stomach wall tissue. The anchor includes a loop. During use, the implant device is inserted through the loop and expanded such that it retains its position within the loop until removed. Instruments for implanting and explanting the implant device are also described.

WO 2006/127593 A2



(84) **Designated States** (*unless otherwise indicated, for every kind of regional protection available*): ARIPO (BW, GH, GM, KE, LS, MW, MZ, NA, SD, SL, SZ, TZ, UG, ZM, ZW), Eurasian (AM, AZ, BY, KG, KZ, MD, RU, TJ, TM), European (AT, BE, BG, CH, CY, CZ, DE, DK, EE, ES, FI, FR, GB, GR, HU, IE, IS, IT, LT, LU, LV, MC, NL, PL, PT, RO, SE, SI, SK, TR), OAPI (BF, BJ, CF, CG, CI, CM, GA, GN, GQ, GW, ML, MR, NE, SN, TD, TG).

Published:

— *without international search report and to be republished upon receipt of that report*

For two-letter codes and other abbreviations, refer to the "Guidance Notes on Codes and Abbreviations" appearing at the beginning of each regular issue of the PCT Gazette.

RESTRICTIVE AND/OR OBSTRUCTIVE IMPLANT
SYSTEM FOR INDUCING WEIGHT LOSS

5 FIELD OF THE INVENTION

The present invention relates generally to the field of implants for inducing weight loss in patients, and specifically to devices and methods for reducing the effective volume of a patient's stomach and/or creating restrictions to slow passage of food into the stomach.

10

BACKGROUND OF THE INVENTION

An anatomical view of a human stomach S and associated features is shown in Fig. 1A. The esophagus E delivers food from the mouth to the proximal portion of the stomach S. The z-line or gastro-esophageal junction Z is the irregularly-shaped border
15 between the thin tissue of the esophagus and the thicker tissue of the stomach wall. The gastro-esophageal junction region G is the region encompassing the distal portion of the esophagus E, the z-line, and the proximal portion of the stomach S.

Stomach S includes a fundus F at its proximal end and an antrum A at its distal end. Antrum A feeds into the pylorus P which attaches to the duodenum D, the proximal
20 region of the small intestine. Within the pylorus P is a sphincter that prevents backflow of food from the duodenum D into the stomach. The middle region of the small intestine, positioned distally of the duodenum D, is the jejunum J.

Fig. 1B illustrates the tissue layers forming the stomach wall. The outermost layer is the serosal layer or "serosa" S and the innermost layer, lining the stomach interior, is
25 the mucosal layer or "mucosa" MUC. The submucosa SM and the multi-layer muscularis M lie between the mucosa and the serosa.

Prior art treatments for obesity range from diet and medication to highly invasive surgical procedures. Some of the more successful surgical procedures are the vertical banded gastroplexy or the proximal gastric pouch with a Roux-en-Y anastomosis.
30 However, known complications are present with each of these procedures. More successful and less invasive options are desired.

BRIEF DESCRIPTION OF THE DRAWINGS

Fig. 1A is a schematic illustration of a human stomach and a portion of the small intestine.

Fig. 1B is a cross-sectional perspective view of a portion of a stomach wall,
5 illustrating the layers of tissue forming the wall.

Fig. 2 is a side elevation view of one embodiment of an implant system, including an endoscope, delivery tool, implant, and anchor.

Fig. 3A is a schematic illustration of a human stomach illustrating a tissue tunnel formed at the gastro-esophageal junction region of a stomach.

Fig. 3B is a cross-section view of the tissue tunnel of Fig. 3A, taken along the
10 plane designated 3B-3B.

Fig. 3C is a cross-sectional perspective view of a portion of stomach wall, showing another type of tissue tunnel that may be used.

Fig. 3D is a cross-sectional top view of a stomach showing three such tissue
15 tunnels in tissue plications formed on the wall of a stomach.

Fig. 4A is a cross-section view of a stomach taken along the plane designated 4A-4A in Fig. 3A and further illustrating retention of two anchors of the type shown in Fig. 2 within the tissue tunnels.

Fig. 4B is a cross-section view similar to Fig. 4A showing an alternative
20 arrangement of two anchors of the type shown in Fig. 2 within the tissue tunnels.

Fig. 4C is a perspective view of an alternative embodiment of an anchor.

Fig. 4D is a cross-section view similar to Fig. 4A showing a second alternative
embodiment of an anchor.

Fig. 5A is a side elevation view of an implant in the radially expanded position.

Fig. 5B is a side elevation view of the implant of Fig. 5A in the streamlined
implantation position.

Fig. 5C is a cross-sectional side elevation view of an implant positioned within a
stomach.

Fig. 6 is a perspective view of an alternative embodiment of an implant.

Fig. 7 is a cross-sectional side elevation view of a second alternative embodiment
of an implant.

Figs. 8A through 8F are a sequence of drawings illustrating a method for forming a tissue tunnel of the type shown in Fig. 3A on the wall of a stomach.

Fig. 9A is a cross-sectional view similar to Fig. 4A showing use of a third alternative embodiment of an anchor. Two such anchors are shown connected to two
5 plications formed in the stomach wall.

Fig. 9B is a cross-sectional side view taken along the plan designed 9B-9B in Fig. 9A.

Figs. 10A through 10F are a sequence of drawings illustrating use of the system of Fig. 2 to position an implant.

10 Figs. 11A and 11C are a sequence of drawings illustrating use of the system of Fig. 2 to remove an implant.

Fig. 12 is a cross-section view similar to Fig. 4A illustrating a fourth alternative anchor embodiment.

Fig. 13 illustrates use of the anchor of Fig. 12 to support an implant.

15 Fig. 14 illustrates use of the anchor of Fig. 12 to support an alternative implant.

DETAILED DESCRIPTION

The drawings show a number of implants intended to induce weight loss in one or more of a variety of ways, as well as anchoring devices that support such implants within
20 the stomach.

For the purposes of this application, the terms "restrictive devices", "satiation devices," or "obstructive devices" will be used to mean implants intended to induce weight loss in one or more of a variety of ways. These include, but are not limited to, slowing the rate at which food passes from the esophagus into the stomach, physically
25 restricting the amount of food that can be consumed, effectively reducing the stomach volume, and/or imparting pressure against portions of the GI system (e.g. stomach, esophagus, esophageal sphincter, etc) causing the patient to experience sensations of fullness, and/or affecting levels of hormones or other substances in the body that control or affect feelings of hunger, and/or affecting the amount of ingested food absorbed by the
30 body. The anchoring devices and methods described herein are useful for various types of satiation implants, including those not specifically described herein and including those positionable in the esophagus, the gastro-esophageal junction region and other portions of the stomach including the proximal stomach, fundus, antrum, etc.

The devices may be provided in one or more kits, which may further comprise instructions for use according to any of the implantation and/or retention methods described herein. Optionally, such kits may further include any of the other system components described in relation to the devices and associated methods, and any other materials or items relevant to those devices and methods. For example, kits may include endoscopic or laparoscopic stapling, suturing and/or cutting instruments, guidewires, positioning mandrels, and any other tools needed to carry out the procedure.

It should be noted that although the embodiments are described in the context of satiation devices, certain of the described components and methods might be equally suitable with other types of implants. These implants include, but are not limited to prosthetic valves for the treatment of gastro-esophageal reflux disease, gastric stimulators, pH monitors and drug eluting devices that release drugs, biologics or cells into the stomach or elsewhere in the GI tract. Such drug eluting devices might include those which release leptin (a hormone which creates feelings of satiety), Ghrelin (a hormone which creates feelings of hunger), octreotide (which reduces Ghrelin levels and thus reduces hunger), Insulin, chemotherapeutic agents, natural biologics (e.g. growth factor, cytokines) which aid in post surgery trauma, ulcers, lacerations etc. As yet another example, the implant may provide a platform to which specific cell types can adhere, grow and provide biologically-active gene products to the GI tract. As other alternatives, an implant may provide a platform for radiation sources that can provide a local source of radiation for therapeutic purposes, or provide a platform whereby diagnostic ligands are immobilized and used to sample the GI tract for evidence of specific normal or pathological conditions, or provide an anchor point for imaging the GI tract via cameras and other image collecting devices.

It should also be noted that certain embodiments described herein have applicability for retaining implants in parts of the body outside the GI system. Thus, the term "implant" will thus be used to refer to satiation devices as well as other types of medical devices that may be implanted in the esophagus, gastro-esophageal junction, stomach, elsewhere within the GI tract, or in other hollow organs, vessels, and cavities of the body.

Fig. 2 shows one embodiment of an implant system 10 for inducing weight loss. System 10 includes a satiation implant 12, and one or more anchors 14 for supporting the implant within a stomach, such as in the region of the gastro-esophageal junction, and a

delivery tool 16 for use in introducing and positioning the implant 12. System 10 may optionally include an endoscope 18, which may be one of various endoscopes available for use in endoscopic procedures.

Anchor 14 includes a fastener 20 and a loop 22. Fastener 20 serves as a coupling
5 device that enables the anchor to be coupled to a tissue structure within the stomach. It is preferably a C-bar type fastener and includes male and female connectors 24, 26 that engage with one another as indicated by arrows in Fig. 2. Referring to Fig. 3A, fastener 20 is proportioned to be suspended from a tissue tunnel 28 formed using stomach wall tissue as will be discussed in more detail in connection with Figs. 8A through 8F. During
10 implantation of the anchor, one connector 24 of fastener 20 is preferably threaded through the tissue tunnel 28 and engaged with the other connector 26 to form the fastener into a loop encircling a portion of the tissue tunnel. This is advantageous in that the anchor 14 may be coupled to the tissue without penetration of the mucosal tissue by the anchor 14 or associated sutures, staples, etc, although such penetration may be used if desired. Anchor
15 14 may be formed of a flexible material that will withstand the acidic environment of the stomach. Examples of such materials include, but are not limited to polyesters (e.g. Dacron® polyester), ePTFE fabric (e.g. GoreTex® fabric or others), urethanes such as ChronoFlex® polyurethane, nylon fabrics, silicone, other polymeric materials.

The anchor 14 may be used alone or in combination with one or more additional
20 anchors. As illustrated in Fig. 4A, in a first embodiment two or more of such anchors 14 are positioned in separate tissue tunnels 28, with the loops 22 of the anchors 14 roughly aligned with one other. This arrangement allows the anchors to be independent of one another so as to minimize tensile forces between the anchors in response to movement of the stomach walls. Alternatively, the anchors may be interconnected. For example in the
25 arrangement shown in Fig. 4B, the anchors are positioned with the male connector 24 of each anchor coupled to the female connector 26 of the other anchor. In a variation of this embodiment, a single anchor may be used in which a single loop (similar to loop 22) is provided with two or more fasteners 20 connected to it. In either of these latter
30 embodiments, an element of play can be built into the loop so as to minimize tensile forces between the fasteners. For example, as shown in Fig. 4C, the loop 22a may be formed of mating components that slide relative to one another in response to movement of the stomach walls.

Fig. 4D illustrates yet another alternative anchor 14b in which the anchor 14b is formed of a flexible elongate band having mating elements such as connectors 24b, 26b. This anchor 14b may be implanted by feeding one end of the band through two or more tissue tunnels 28 in a manner which forms a portion of the band into a loop 22b as shown. The sections of the band forming the loop may lie on top of one another as shown in Fig. 4D, or they may be intertwined.

Referring again to Fig. 2, implant 12 is proportioned to be securely held within the loop 22 of the anchor 14. In one embodiment, implant 12 includes a relatively narrow waist section 30 situated between an orad section 32 and an aborad section 34. With this arrangement, the loop 22 of anchor 14 can engage the waist section 30 as described with respect to Figs. 10E – 10F so as to support the implant 12 within the stomach.

Referring to Figs. 2 and 5A, implant 12 preferably includes a an orad ring 36 surrounding an orad opening 136 and an aborad opening 138 surrounded by ring 38. The waist section 30 may include a ring similar to rings 36, 38.

A passageway 40 ends between the openings 136, 138. Passageway 40 allows for access by an endoscope and other instruments as detailed in the Implantation section below. The implant 12 may be hollow, in which case the passageway 40 may be continuous with the hollow interior of the implant. Alternatively, the implant may be toroidal, with the passageway forming the central opening of the toroid (see Fig. 6).

Implant is preferably made of a flexible, self expandable, material suitable for use within the stomach. Examples include polyesters (e.g. Dacron® polyester), ePTFE fabric (e.g. GoreTex® fabric or others), urethanes such as ChronoFlex® polyurethane, nylon fabrics, silicone, latex, or other polymeric materials. As shown in Fig. 5A, implant 12 may include a frame 42 (e.g. which may be formed of a mesh, strut elements 44 and/or other features). The frame is preferably manufactured using nitinol or shape memory polymers to facilitate self-expansion of the implant. Frame 42 may be provided with a covering or coating formed of Dacron® polyester, silicone, urethanes or other material, or it may be provided without a covering or coating. The implant materials are sufficiently flexible to allow the implant 12 to be manipulated to a streamlined position, such as by applying tension between the orad section 32 and the aborad section 34 as shown in Fig. 5B, or by compressing the implant radially inwardly. The waist 30 and the rings 36, 38 and may include small holes 31, 37 and 39, respectively, for receiving wires, sutures, or other elements that may be used to anchor the implant 12 on an implantation tool.

The shape and dimensions of the implant 12 are selected to induce weight loss by restricting patient eating in one or more ways. For example, referring to Fig. 5C, the implant 12 may be contoured such that when the orad section 32 is positioned in close proximity to the surrounding walls of the gastro-esophageal junction region, very little
5 food can pass around the implant 12, and the dimensions of the passageway 40 restrict the amount of food that can pass through the passageway 40 at one time. Thus, the restrictive and obstructive nature of the device slows passage of food from the esophagus into the stomach, and prevents the patient from eating large quantities of food. In various
10 embodiments, the dimensions of the passageway 40 may be selected based on the amount of flow restriction needed for the patient. In other embodiments, the passageway 40 may be sealed, extremely narrow, or absent from the implant so as to cause all ingested food to eventually flow around the limited space around the perimeter of the implant.

The implant preferably includes soft, atraumatic edges in regions that might contact the surface of stomach mucosa, to prevent irritation of the tissue. In one
15 alternative embodiment, the outer profile of the implant may be spherical or semi-spherical such that the device can roll over the stomach surface during movement of the stomach.

In an alternative implant 12a shown in Fig. 6, the surface of orad section 32a is substantially flat. The aborad section 34a may be curved as shown, or it may be flat.

20 Fig. 7 shows an alternative embodiment of an implant 12b which functions as a space occupier in addition to or as an alternative to restricting flow of food from the esophagus to the stomach. In the Fig. 7 embodiment, the aborad section 34b is sufficiently large to occupy sufficient space within the stomach to create feelings of satiety and/or to reduce stomach capacity. In some embodiments, the implant 12b may
25 have an expanded volume in the range of approximately 200 – 700 cc, sufficient to fill a portion of the stomach, thereby causing the patient to feel full and thus limiting food intake. Implant 12b may be inflatable, and it may include an inflation port 46 or a region of self-sealing material, either of which may be engaged by an inflation tube introduced into the stomach after the implant is positioned.

30 The Fig. 7 embodiment may be positioned at various locations within the stomach. For example, it may be positioned in the gastro-esophageal junction region or the fundus where it may function to occupy space so as to reduce effective stomach volume, but also to create restrict the rate at which food can descend from the esophagus into the stomach

as discussed with prior embodiments. Alternatively, it may be positioned in the antrum A or the pylorus P (Fig. 1A) to reduce the effective stomach volume and/or to slow the exit of food from the stomach into the intestines.

Referring again to Fig. 2, implantation tool 16 for the implant 12 of Fig. 2
5 includes an outer shaft 15, a middle shaft 17 and an inner shaft 19. Outer shaft 15 is arranged to receive the orad section 32 of the implant and may include a broadened mount 21 to facilitate seating of the orad ring 36 on the shaft 15. Similarly, inner shaft may also have a mount 23 for receiving the aborad section 34 of the implant 12, and middle shaft 17 might also include a mount 25 for accommodating the waist section 30 of
10 the implant 12. Shafts 15, 17, 19 are slidable telescopically relative to one another. Thus, the shafts may be moved to an expanded position to spread the mounts 21, 23, 25 relative to one another and to thus elongate the implant into the streamlined orientation shown in Fig. 5B. Similarly, the shafts may be adjusted to close the spacing between the mounts 21, 23, 25, thereby allowing the implant to assume its natural orientation.

Retraction of the shafts may be actuated using release tabs 43a, 43b on the handle
15 of the implantation tool. For example, the implantation tool 16 may include spring loaded latches (not shown) that retain the tool in the expanded position and that are disengaged using the release tabs 43a, 43b. Thus, for example, depression of release tab 43a will release the latch associated with outer shaft 15, thus causing the outer shaft to slide
20 distally relative to the middle shaft 17. Similarly, actuation of release tab 43b will disengage the latch associated with inner shaft 19 so as to allow the inner shaft to slide proximally relative to the middle shaft. In this embodiment, movement of the shafts upon release of the latches may be spring biased or manual.

Small holes 27a, b, c may be formed in each of the shafts 15, 17, 19 for receiving
25 wires, sutures, or other elements that may be used to anchor the implant 12 on the implantation tool 16.

Alternative implantation tools may rely on other mechanisms for delivering the
implant to the desired location. For example, alternative tools may include retractable elements for grasping portions of the implant (e.g. the rings or loops such as the loops 84,
30 86 shown in Fig. 11A) and then releasing the implant when it is the proper position. Alternative embodiments may also rely solely on the shape memory properties of the implant for expansion of the implant within the body.

Anchor Implantation

Exemplary methods for implanting anchors 14 will next be described.

In a preferred method, tissue tunnels 28/28a (Figs. 3A-3C) are formed to provide an anatomical structure on the stomach wall to which the anchors 14 may be coupled.

5 The tunnels may be formed using laparoscopic, endoscopic, and/or surgical approaches. Various procedures for forming tissue s/tunnels are described in Applicant's prior application WO 2005/037152, entitled "Devices and Methods for Retaining a Gastro-Esophageal Implant" published April 25, 2002, which is commonly owned with the present application and which is incorporated herein by reference.

10 As discussed in the prior application, tissue tunnels may be created using tissue plications formed by grasping sections of tissue and stapling or suturing the tissue together to form tissue structures. Such structures may be tunnel-like in the sense that they have an interior space bounded by tissue, and openings positioned so that an anchor or other portion of a medical device may be passed through one opening, through the
15 interior space of the tunnel, and out the other opening. The interior walls of the tunnel may lie in contact with one another, collapsing the interior space in the same way the space within a shirt is collapsed. In other embodiments, the tunnels may retain a more tubular shape.

Several such procedures rely in part on adhesion of the serosal tissue lining the
20 outer surface of the stomach. It has been found that serosal tissue layers can adhere to form relatively strong bonds when held in apposition to one another.

For example, the tissue tunnels might be similar to the tunnels 28 shown in Figs. 3A and 3B, or they might alternately be tunnels 28a of the type shown in Figs. 3C and 3D created by forming holes 90 in serosal tissue plications 92. Methods for forming either
25 type of tissue tunnel may be carried out in a manner that takes advantage of the strong adhesions formed when serosal tissue surfaces are held in apposition. Other methods not specifically described herein may also be used without departing from the scope of the present invention.

Figs. 8A through 8F illustrate one method of forming tissue tunnels (also referred
30 to as tissue pockets) such as the type shown in Figs. 3A and 3B.

The orientation of the tunnels is chosen to best accommodate the particular type of anchor/implant arrangement to be used. For example, tunnels may have an orad-aborad orientation as shown in Fig. 8F, or a more transverse orientation as in Figs. 3A and 4A.

Referring to Fig. 8A, a rod 48 is positioned on the exterior surface of the stomach, and sutures 50 are attached to the rod 48 and passed through the stomach walls. The sutures 50 are drawn inwardly using an endoscopic grasper (not shown) to “tent” a section 52 of tissue of the type shown in Fig. 8C. If desired, the method may be
5 performed without the rod 48 as shown in Fig. 8B, in which case a pair of sutures 50a may be passed from the stomach interior, through the stomach wall, and then back into the stomach interior, and then drawn inwardly using an endoscopic grasper 54 to tent the tissue as shown in dashed lines.

Next, a line 56 of staples or sutures are applied across the tented tissue from the
10 mucosal side of the stomach – thereby forming an enclosed pocket 58 on the exterior surface of the stomach as shown in Fig. 8D. The rod 48 (if used) is enclosed within the pocket 58. Stapling/suturing may be performed using an endoscopic stapler 60a passed through the esophagus into the stomach, or using a laparoscopic stapler 60b introduced into the stomach through a surgical gastronomy site – both of which are shown in Fig. 8C.
15 The stapler/suture device preferably has characteristics that will form a suture/staple line 56 that is sufficiently patent to seal the serosal tissue together to prevent stomach leakage prior to complete serosal adhesion, but that ensures good blood flow so as to promote healing of the stapled tissue. For example, a conventional stapler modified to have a staple cartridge in which alternate staples have been removed may achieve this purpose.

20 A collar 62 may be placed around the tented tissue 52 as shown in Fig. 8C prior to suturing/stapling so as to apply tension to the wall tissue to facilitate suturing or stapling.

The suture line 56 holds the serosal layers of tissue together as shown in Fig. 8E, thereby holding the pocket 58 together. The ends 64 of the pocket are cut, turning the enclosed pocket 58 into a tissue pocket or tunnel 28 having ends that open into the
25 stomach interior. The rod 48, if used, is removed from the tunnel 28. The tissue preferably heals together to form an adhesion that maintains the tunnel.

Because the tissue tunnel 28 is formed of serosal tissue, it may be desirable to line the tunnel/ 28 with a stent-like device 68 or another liner to both reinforce the and protect the serosal surface from the acidic stomach environment. Many of the embodiments
30 described above rely upon formation of tissue adhesions between opposed tissue layers. The liner may also function as scaffolding that promotes tissue ingrowth and/or function to reinforce the adhesions that form.

The procedure is repeated to form as many tunnels as are needed to support the desired number of anchor(s) in the stomach. Over time, the regions of tissue held in apposition will adhere together due to the body's physiological or biological response, such as formation of fibrous tissue or scar tissue, growth of new tissue, or a growing, healing, or knitting together of the opposed tissue layers. The term "adhesion" will be used in this application to refer to the adhering of opposed tissue layers as a result of any physiological or biological response, including but not limited to those listed above.

To form tissue tunnels 28a of the type shown in Figs. 3C and 3D, a serosal plication 92 is formed. More specifically, tissue within the stomach interior is pinched together to draw serosal layers on the stomach exterior into contact with one another, thereby forming a folded tissue tab or plication 92. A hole 90 is formed in the plication 92 and staples 94 or sutures, etc., are placed around the hole 90 to keep the tissue pinched together until a serosal adhesion forms. Multiple plications 92 may be formed as shown in Fig. 3D.

Once the tunnels 28 (or 28a) are formed, one or more anchor(s) 14 may be coupled to the tunnels. In a preferred method, the tunnels are allowed to heal and then a later procedure is carried out to couple the anchors 14 to the tunnels and to position the implant 12. If desired, however, the anchors may be implanted during the same procedure in which the tunnels are formed, and the implant may then be positioned in a later procedure after the tunnels have healed. Naturally, tunnel formation, anchor attachment, and implant positioning may also be performed in three separate procedures.

To implant the anchors 14, each anchor is passed through the esophagus and into the stomach, preferably under endoscopic visualization. The anchor 14 and associated instruments may be passed down a sheath positioned in the esophagus so as to protect the surrounding tissues. A portion of the fastener 20 of the anchor is passed through the tissue tunnel 28, and the connectors 24, 26 are engaged to form the fastener 20 into a loop as shown in Fig. 4A. An endoscopic grasper or other suitable endoscopic instruments may be used for this purpose. According to the first embodiment, a second anchor is coupled to a second tissue tunnel as shown. At this point, the loops 22 of the anchors 14 preferably overlap and are ready to receive the implant 12.

Figs. 9A and 9B illustrate an alternative method for implanting anchors 14d. According to this method, anchors 14d are attached to tissue plications 28d formed in the stomach wall. Various methods for forming plications are described in WO

2005/037152, entitled "Devices and Methods for Retaining a Gastro-Esophageal Implant" published April 25, 2002. According to one method of forming a serosal plication, tissue within the stomach interior is pinched together (using an endoscopic grasper, for example) to pinch serosal layers on the stomach exterior into contact with one another, thereby forming folded tissue tab as shown. A reinforcing patch 9 may be positioned between the serosal tissue layers. The patch may function as scaffolding that promotes tissue ingrowth and/or function to reinforce the adhesions that form. Sutures 11 (which may be bioabsorbable), pledgets 13, t-bars or other fastening means are used to hold the tissue layers together at least until adhesions bond the tissue layers together. These fasteners may also be used to attach the anchors 14d to the plication as shown, although in an alternative method the anchors 14d are coupled to the plications 28d using sutures, staples or other fasteners after the plications have healed.

Eventually, adhesions form between the tissue layers (and through and/or onto the interstices of the patch) and serve to reinforce the bond between the tissue layers.

The patch may be a synthetic or non-synthetic mesh, porous material, slotted material, or any other material through which adhesions will form or onto which tissue will grow. Examples include, but are not limited to, polypropylene, materials sold under the trade names Goretex or Dacron, or tissue graft material such as the Surgisis material sold by Wilson Cook Medical, Inc. The material may be treated with tissue-ingrowth promoting substances such as biologics.

Implant Positioning

Fig. 10A illustrates one method of mounting the implant 12 to the tool 16 in preparation for implantation. In this figure, the implant walls are shown as transparent so that the orad and aborad rings 36, 38 and the waist ring 30 can be seen. In a preferred method, the implant is attached to the tool at three attachment points which fall at the orad ring, the aborad ring, and the waist section. In alternative methods the implant may be attached at different locations, such as only the aborad or orad ends of the device, or elsewhere.

To mount the implant according to the method of Fig. 10A, a first retention element such as nitinol wire 29a is introduced into an opening at the open proximal end of the tool and passed distally through the lumen of the inner shaft 19. The distal end of the wire is then extended through the distalmost one of the holes 27c, through opening 39 in

the aborad ring 38, then inserted back into the lumen of the inner shaft and returned to the proximal end of the tool 16 and may be marked and held together by a tab 41c. The two ends of the wire 29c are retained outside the tool. Similarly, a second nitinol wire 29b is passed down the annular space between the inner shaft 19 and the middle shaft 17, passed out of the middle shaft through one of the openings 27b, then through opening 31 in the waist ring 30 of the implant and back into the annular space via the most proximal one of the openings 27b. The ends of the wire 29b are retained by a tab 41b. This process is repeated at the orad end of the implant to anchor the orad ring 36 using nitinol wire 29a. The relative positions of the shafts 15, 17, 19 are adjusted to place the implant 12 in the elongated position, and then locked in place.

Referring to Fig. 10B, once the implant 12 is assembled onto the implant tool 16, the tool 16 is positioned over the endoscope 18 by sliding the endoscope through the central lumen of the tool's inner shaft 19. Next, the distal end of the endoscope is passed orally into the esophagus, and then through the loops 22 of the anchors 14 previously implanted. The endoscope is retroflexed as shown in Fig. 10C, allowing the surgeon to visually confirm that the endoscope has passed through both loops.

Referring to Fig. 10D, the implant tool 16 is advanced over the endoscope until the waist 30 of the implant 12 is adjacent to the loops 22. The waist of the implant may be marked with identifying markers to simplify this step of the procedure. Once the waist 30 is properly positioned, release tab 43a is depressed to allow the outer shaft 15 of the implant tool 16 to slide distally, causing the orad ring 36 to move closer to the waist 30 thus expanding orad section 32 of the implant as shown in Fig. 10E. Once it is visually confirmed that the expanded orad portion of the implant is properly positioned, wire 29a is withdrawn to disconnect the orad ring 36 from the implant tool 16.

Next, referring to Fig. 10F, the release tab 43b is activated to allow the inner shaft 19 to be withdrawn in a proximal direction, bringing the aborad ring 38 closer to the waist 30 and allowing the aborad portion 34 of the implant to expand. Proper deployment is visually confirmed, and then the wires 29b and 29c are withdrawn to detach the implant 12 from the tool 16.

Removal

Figs. 11A and 11B illustrate one example of a method for removing the implant 12. According to the method of Figs. 11A and 11B, removal is carried out using an

extraction tool 72 comprised of a sheath 74 and a hollow rod 76 telescopically disposed within the sheath 74. Endoscope 18 is slidable through the lumen of the hollow rod 76.

Sheath 74 includes a small side lumen 78. An elongate wire having a hook 80 at its distal end is extendable through the side lumen 78 to deploy the hook 80 from the
5 distal end of the sheath 74. Another hook 82 is positioned on the distal end of the hollow rod.

Initially, the extraction tool 72 is arranged with the hollow rod 76 fully withdrawn into the sheath 74, but with the endoscope 18 extending distally from the distal end of the sheath 74. The tool 72 is introduced into the esophagus such that the sheath 74 is
10 positioned proximally of the implant 12. The endoscope 18 is advanced through the implant 12 and retroflexed as shown in Fig. 11A to permit visualization of the procedure.

Next, hook 80 is advanced through sheath 74 and manipulated to ensnare a retrieval loop 84 on the orad portion of the implant 12. Alternatively, the hook 80 may be used to grasp the orad ring 36 (Fig. 2) of the implant. Once the orad portion of the
15 implant has been engaged, hollow rod 76 is advanced to allow hook 82 to capture a retrieval loop 86 on the aborad end of the implant 12 (or to capture the aborad ring 38). The hollow rod 76 and sheath 74 are moved in opposite directions to elongate the implant 12 as shown in Fig. 11B, and are then simultaneously withdrawn from the stomach (along with the endoscope 18) while maintaining the implant in the elongated position. Once the
20 implant 12 has been explanted, only the anchors 14 remain in place as shown in Fig. 11C.

Alternative Configuration

Fig. 12 illustrates an alternative anchor 14e which may be used to support an implant. Anchor 14e may be a single component or multiple components arranged to
25 form a web-like structure in a gastro-esophageal junction. As discussed with other anchor embodiments, the anchor 14e is preferably linked to tissue tunnels 28, although it may alternatively be coupled to serosal plications as discussed in connection with Figs. 9A and 9B, or it may be attached to the tissue in other ways.

Referring to Figs. 13, anchor 14e may include a loop 22e for receiving an implant
30 12e as described above in connection with other embodiments. The implant 12e may have an hourglass shape defined by a central waist section as with implant 12 of Fig. 2, or it may be tapered as shown in Fig. 13. Referring to Fig. 14, the anchor 14e may also be used to support an implant 12f by simply preventing the implant 12f from descending

further into the gastrointestinal tract. For example, the implant 12f may take the form of a space occupying balloon that is not physically attached or coupled to the anchor 14e.

Implantation of the anchor 14e may be accomplished using techniques described above. The implant 12f may be positioned by coupling an inflation tube to an inflation
5 port in the implant 12f, and then passing the implant 12f down a sheath positioned in the esophagus. Once the implant is within the stomach, the inflation tube is used to inflate the implant 12f, and is then detached from the implant and withdrawn from the body.

The implant 12e may be implanted using a methodology similar to that described in the Implantation section.

10 Various components and methods have been described herein. These embodiments are given by way of example and are not intended to limit the scope of the present invention. It will be apparent to persons skilled in the relevant art that various changes in form and detail may be made therein without departing from the spirit and scope of the invention. This is especially true in light of technology and terms within the
15 relevant art(s) that may be later developed.

It should be appreciated, moreover, that the various features of the embodiments that have been described might be combined in various ways to produce numerous additional embodiments. Also, while various materials, dimensions, shapes, implantation locations, etc. have been described for use with disclosed embodiments, others besides
20 those disclosed may be utilized without exceeding the scope of the invention. For example, the anchoring methods and devices are not limited to use within the gastrointestinal system and may be used for implants placed elsewhere in the body.

Any and all patents, patent applications and printed publications referred to above are incorporated by reference.

WHAT IS CLAIMED IS:

1. An implant system, comprising:
an anchor including a loop and a coupling device configured to couple the
5 anchor to a tissue structure within a patient; and
an implant device positionable within the loop.
2. The implant system of claim 1, wherein the implant device includes a
waist section positioned to seat within the loop.
10
3. The implant system of claim 1, wherein the coupling device includes a free
end extendable through a tissue tunnel defined by the tissue structure to couple the anchor
to the tissue structure.
- 15 4. The implant system of claim 1, wherein the coupling device is configured
to couple the anchor to a tissue plication within a human stomach, and wherein the
implant device is proportioned to slow the rate of passage of food into the stomach to
induce weight loss in the patient.
- 20 5. The implant system of claim 1, wherein the coupling device is configured
to couple the anchor to a tissue plication within a human stomach, and wherein the
implant device is proportioned to significantly reduce the effective volume of the stomach
to limit food intake by the patient.
- 25 6. The implant system of claim 1, wherein the implant device includes a
passage from a distal portion to a proximal portion of the implant device.
7. The implant system of claim 1, wherein the coupling device is configured
to couple the anchor to a tissue plication within a human stomach, wherein the implant
30 device is mountable to an implantation tool, wherein the implantation tool is proportioned
to extend from a mouth of the patient to position the implant device within the loop
positioned within the stomach.

8. The implant system of claim 7, wherein the implant device is expandable for engagement with the loop.

5 9. The implant system of claim 8, wherein a proximal portion of the implant device is mountable to a first portion of the implantation tool, wherein a distal portion of the implant device is mountable to a second portion of the implantation tool, and wherein the first and second portions of the implantation tool are longitudinally moveable relative to one another to expand the implant device for engagement with the loop.

10 10. The implant system of claim 1, further including a plurality of anchors, each including a loop and a coupling device configured to couple the anchor to a tissue structure within a patient, wherein the loops are positionable in the patient in at least partial alignment with one another and wherein the implant device is positioning within the at least partially aligned loops.

15

11. The implant system of claim 10, wherein the implant device includes a passage and wherein the implant tool is extendable through the passage.

20 12. The implant system of claim 7, wherein the implantation tool includes a lumen and wherein the system further includes an endoscope extendable through the lumen.

25 13. The implant system of claim 1, further including instructions for use instructing a user to couple the anchor to a plication formed in tissue and to insert the implant device into the loop of the anchor.

30 14. The implant system of claim 1, further including instructions for use instructing a user to form a tissue tunnel by creating a serosal plication in stomach tissue, to couple the anchor to the tissue tunnel, and to insert the implant device into the loop of the anchor.

15. A method of implanting a medical device, comprising the steps of:
providing an anchor including a loop;

coupling the anchor to tissue within a patient; and
passing an implant device into the loop and retaining the implant device
within the loop.

5 16. The method of claim 15, wherein the tissue is within a human stomach.

 17. The method of claim 16, wherein the tissue is within a gastro-esophageal
junction region.

10 18. The method of claim 15, wherein the implant device includes a waist, and
wherein the retaining step includes seating the waist within the loop.

 19. The method of claim 15, wherein the method further includes the steps of:
forming a plication in body tissue, the plication defining a tissue tunnel;
15 and
 extending a portion of the anchor through the tissue tunnel.

 20. The method of claim 19, wherein the anchor includes a fastener having
first and second ends, wherein the coupling step includes extending the first end through
20 the tissue tunnel and engaging the first and second ends.

 21. The method of claim 15, wherein the passing step includes mounting the
implant device to a distal portion of an implantation tool and extending the distal portion
of implantation tool from a mouth of the patient through the loop positioned within the
25 stomach.

 22. The method of claim 21, wherein the retaining step includes expanding the
implant device within the loop.

 23. The method of claim 22, wherein:
30 the method further includes mounting a proximal portion of the implant device to
a first portion of the implantation tool and mounting a distal portion of the implant device
to a second portion of the implantation tool, and

the expanding step includes longitudinally moving the first and second portions of the implantation tool relative to one another to expand the implant device.

24. The method of claim 15, wherein the coupling step includes coupling a
5 plurality of anchors to the tissue, each anchor including a loop, wherein the passing step includes passing the implant device through the loops and retaining the implant device within the loops.

25. An implant device positionable within the stomach, the implant device
10 including a proximal portion, a distal portion, and reduced-diameter waist portion disposed between the proximal and distal portions.

26. The implant device of claim 25, further including a longitudinal passage
extending through the implant device.
15

27. The implant device of claim 25, further including instructions for use
instructing a user to position the implant device at a gastro-esophageal junction region of
a human stomach.

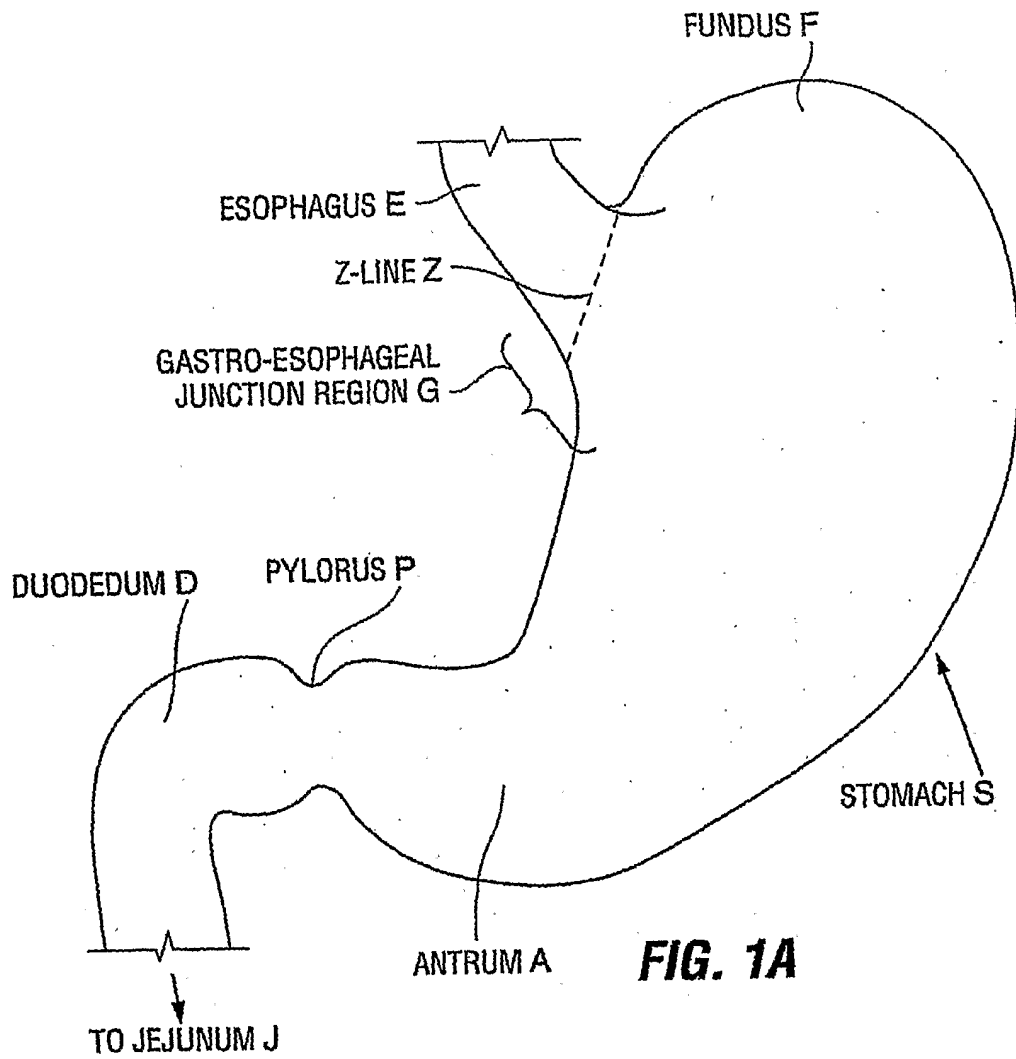

FIG. 1A

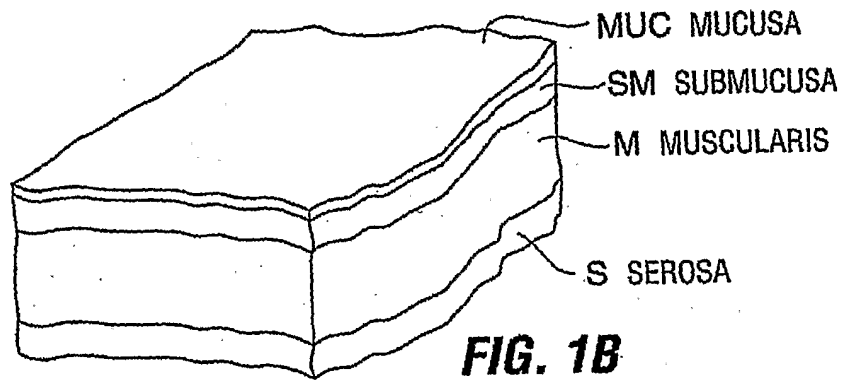
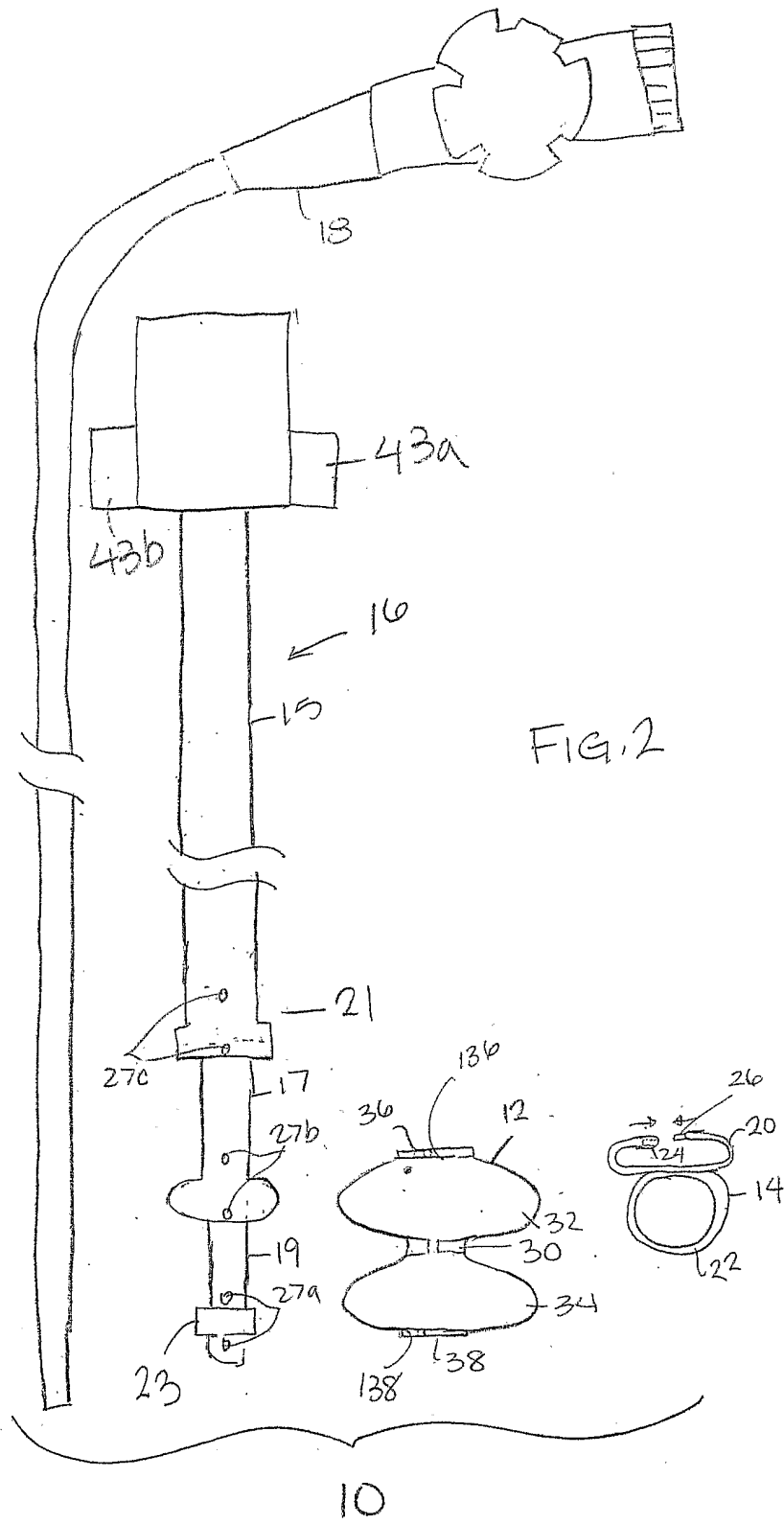

FIG. 1B



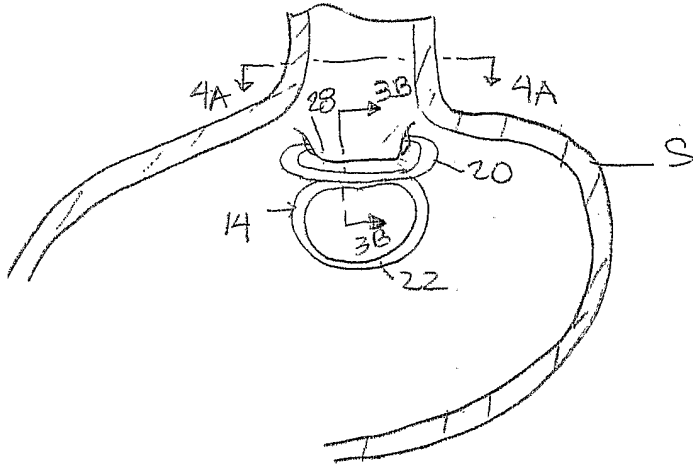

FIG 3A

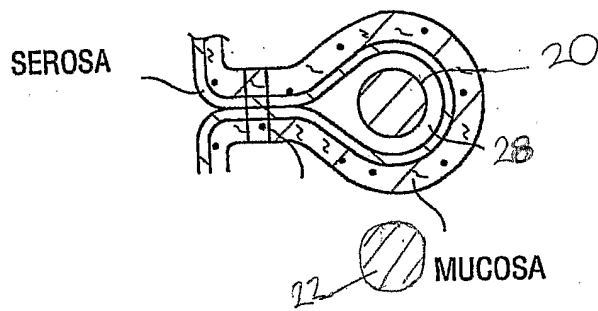

FIG. 3B

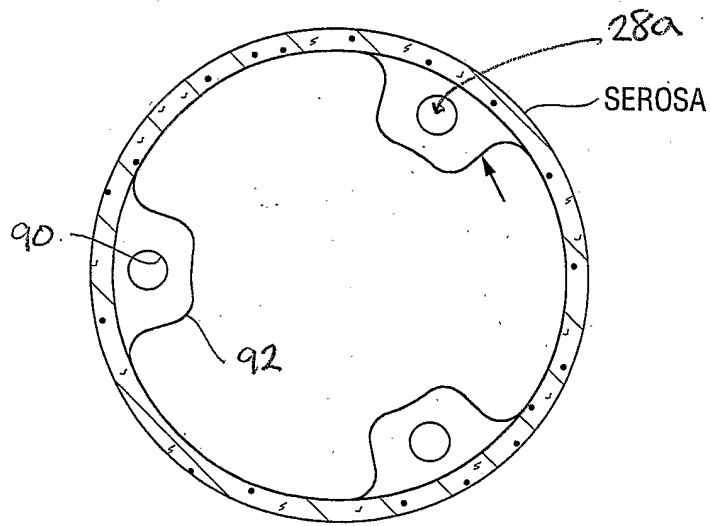
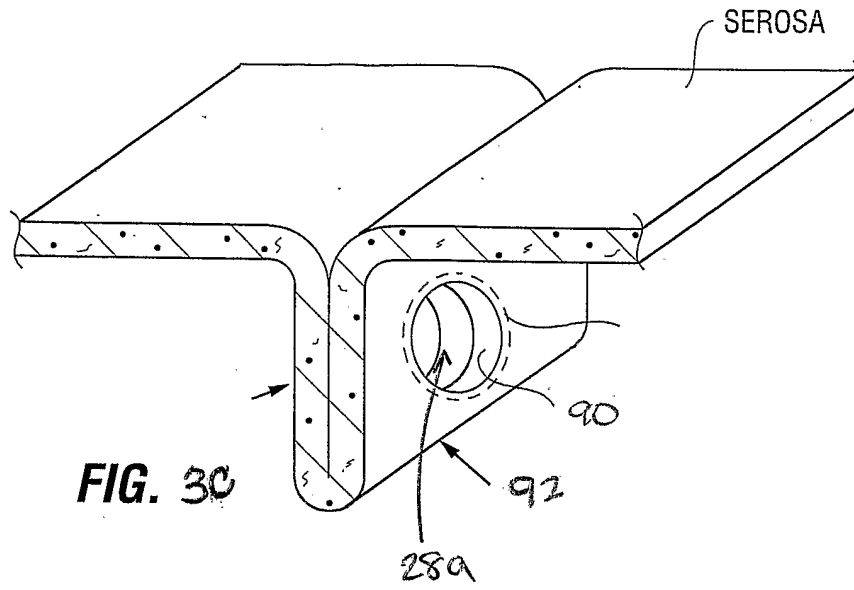
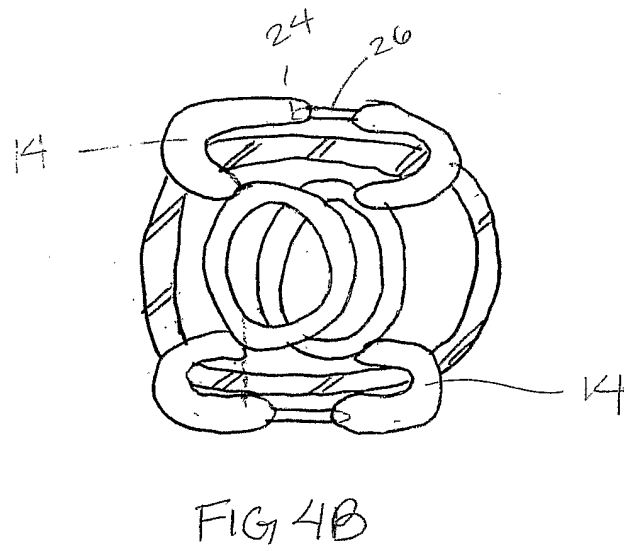
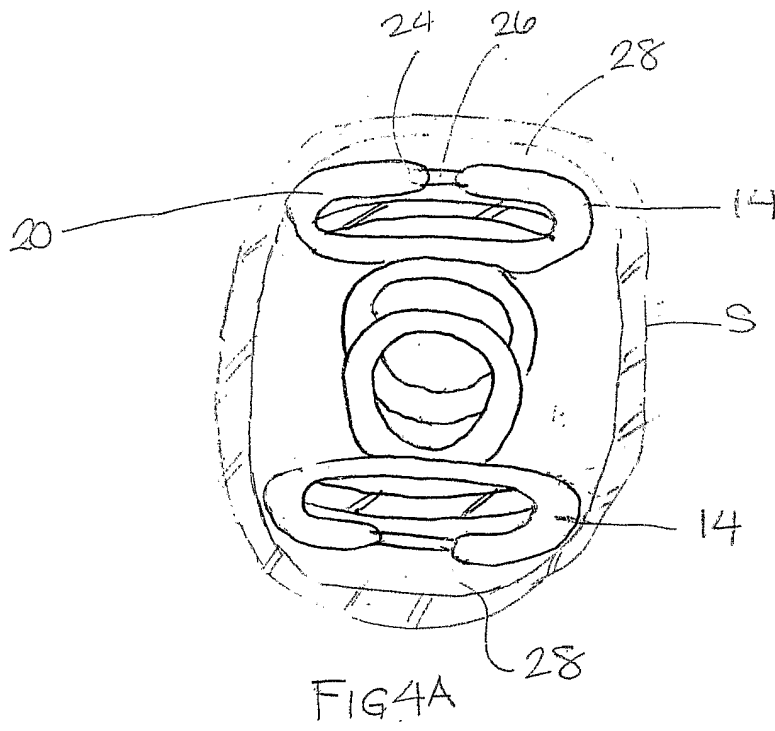
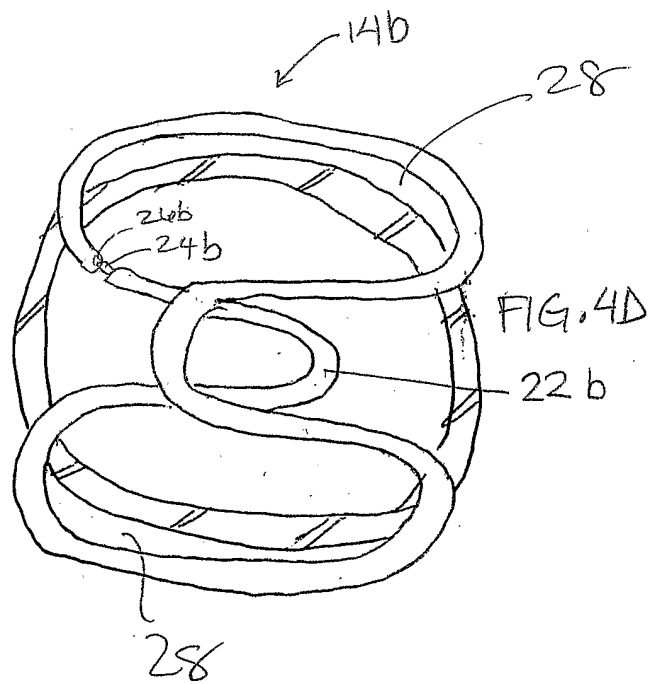
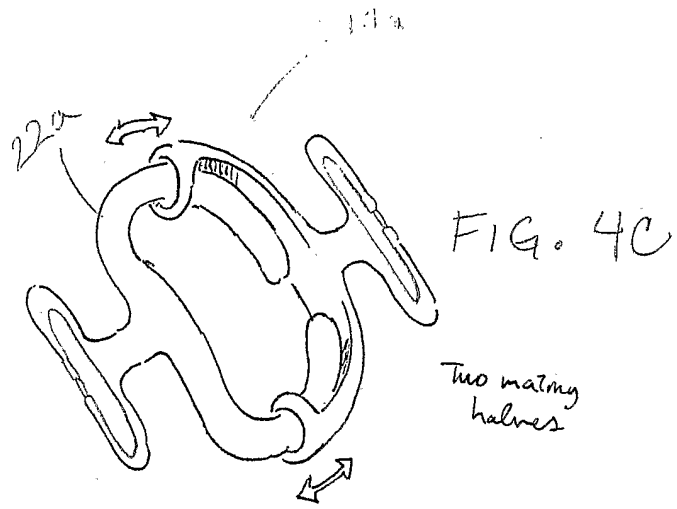
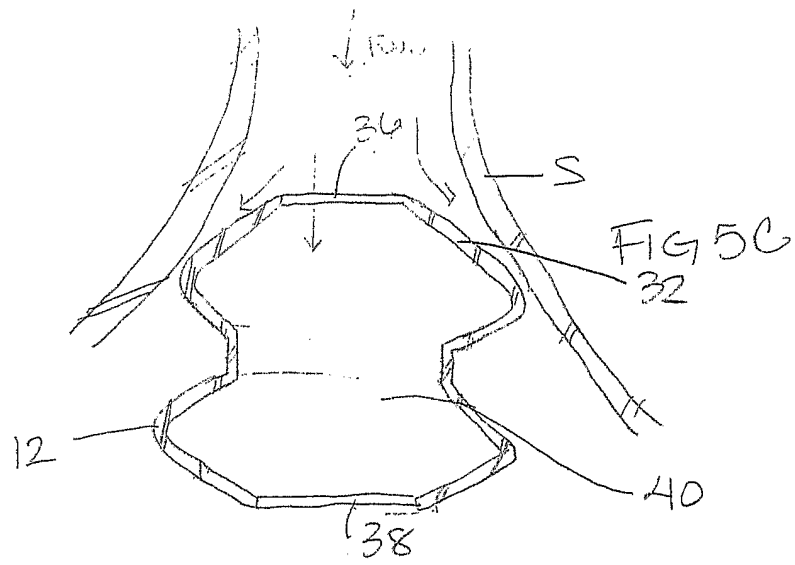

FIG. 3D







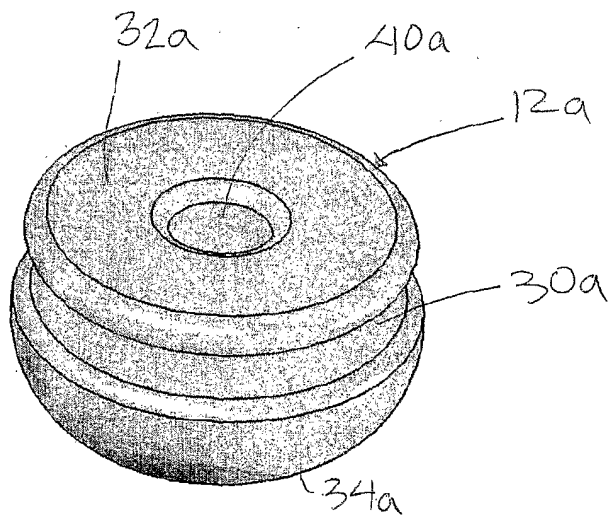
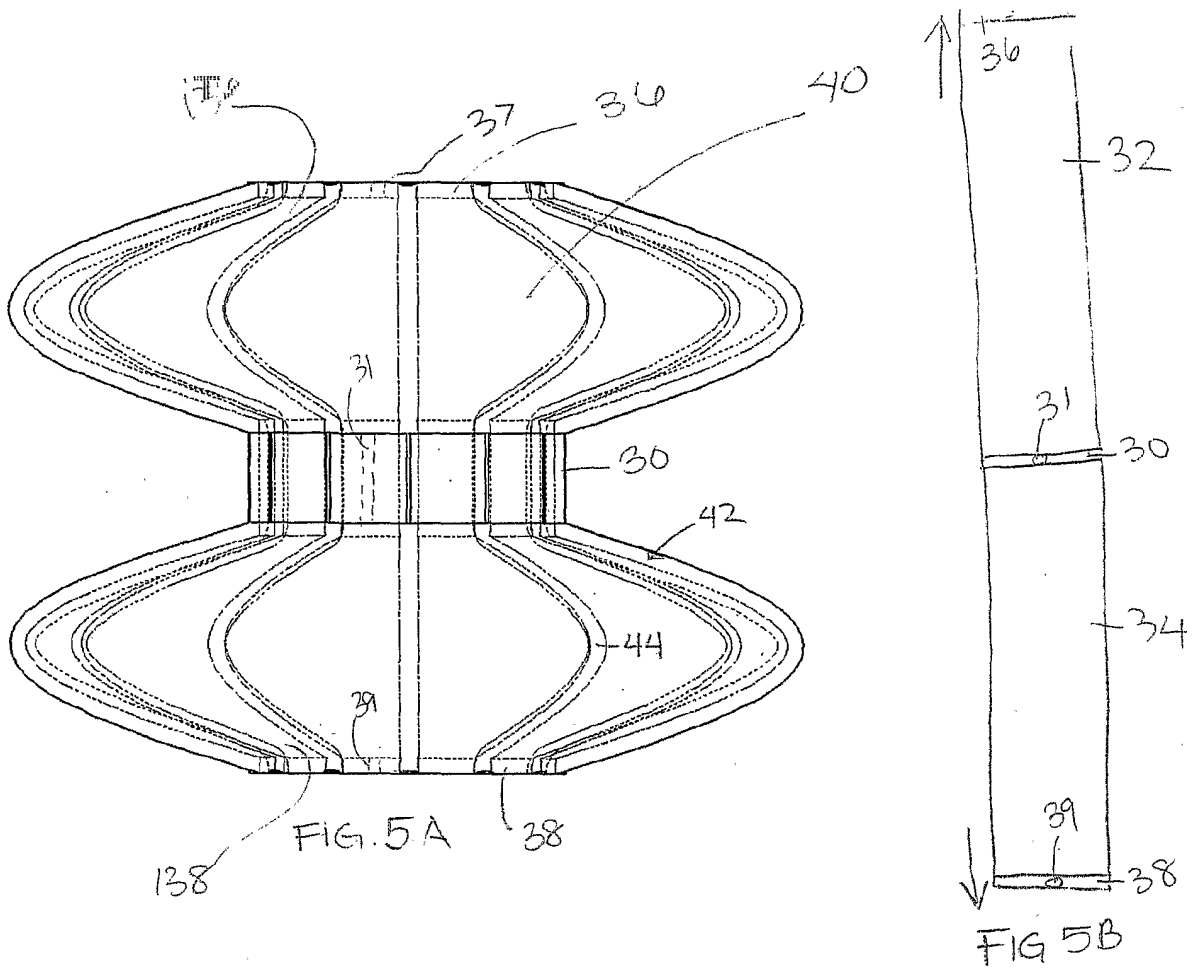

FIG 6

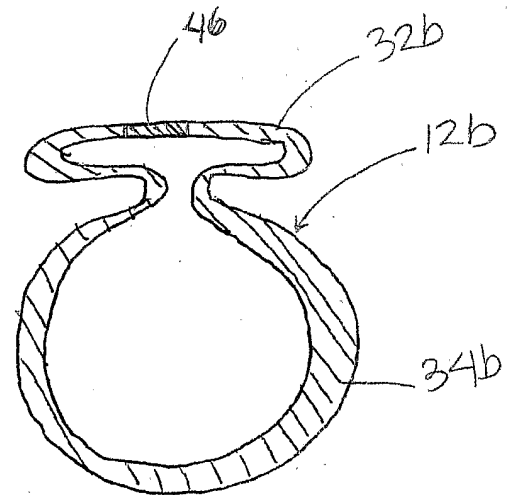

FIG 7

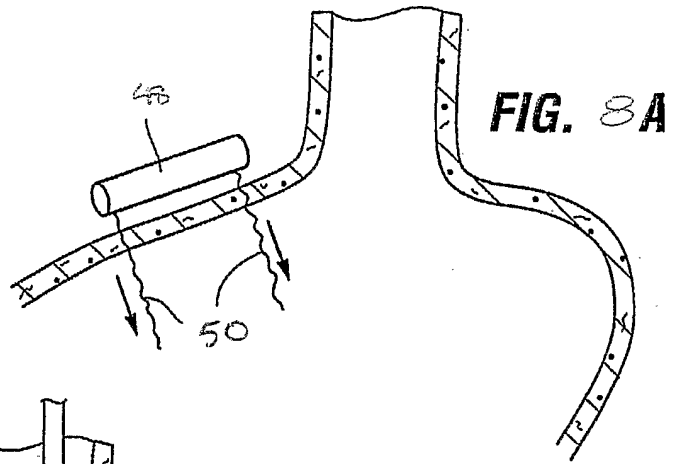

FIG. 8A

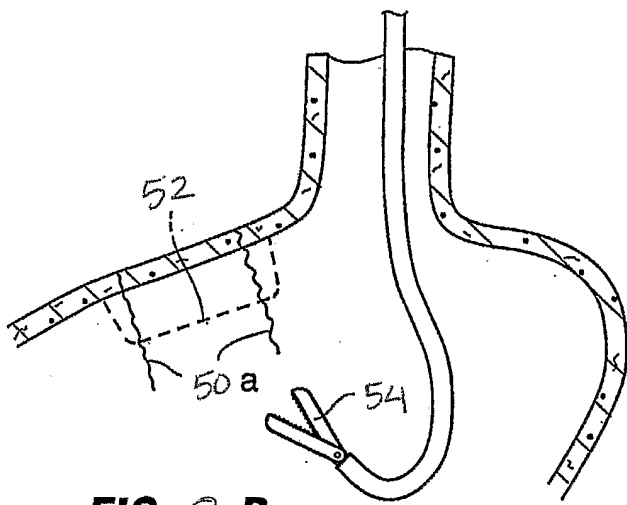

FIG. 8B

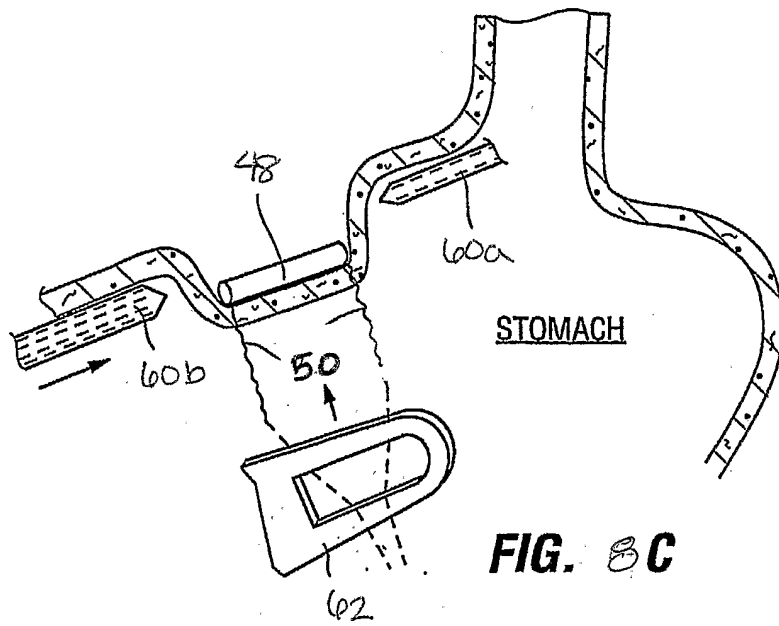
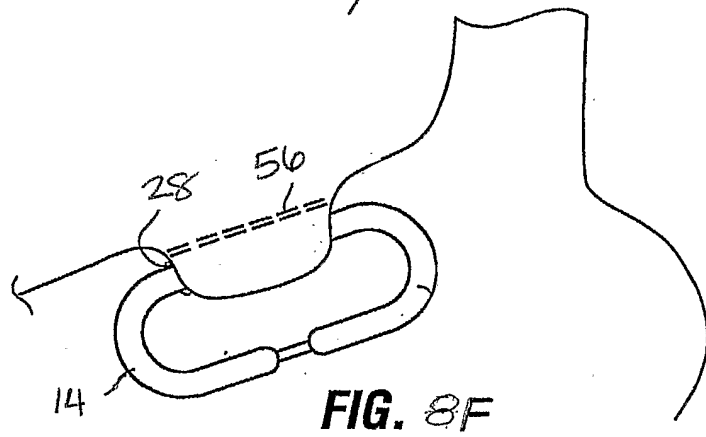
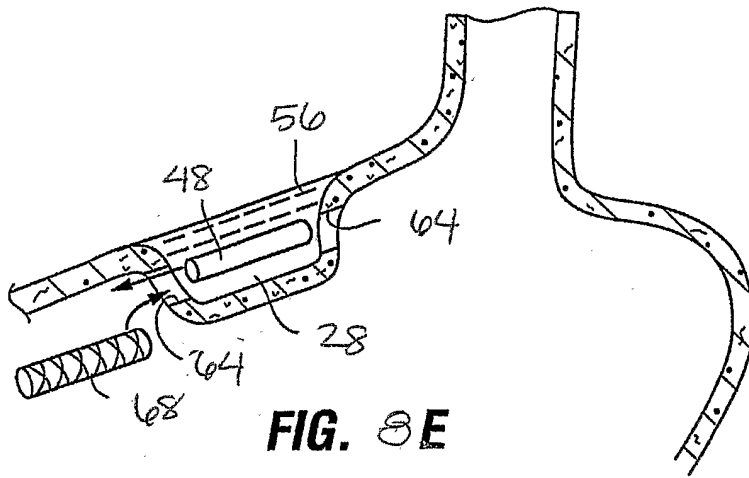
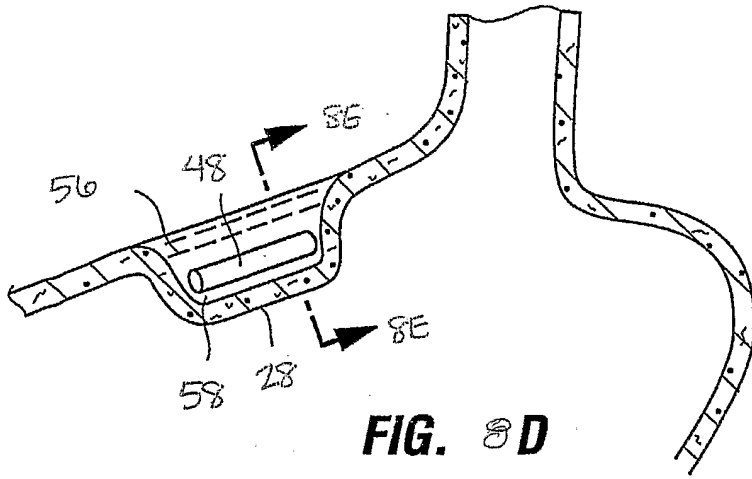
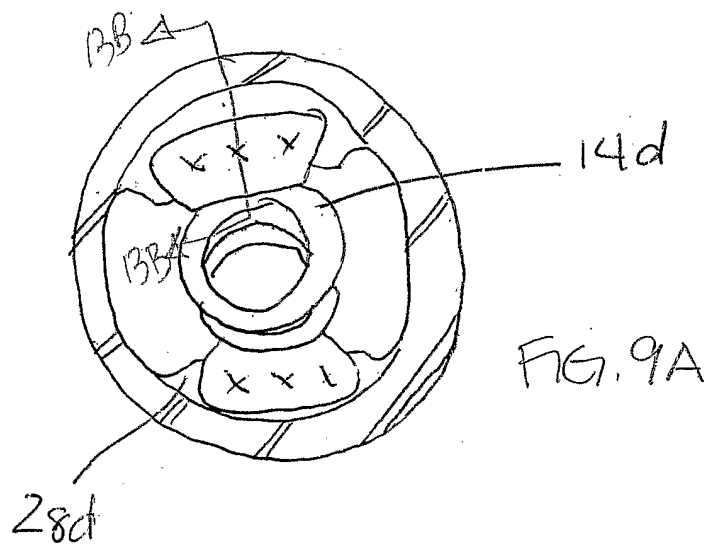
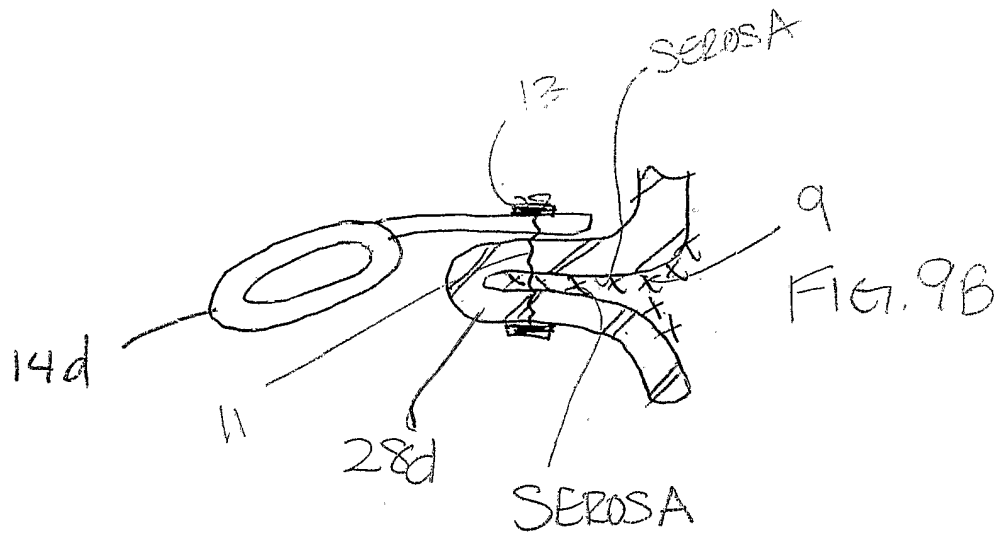

FIG. 8C





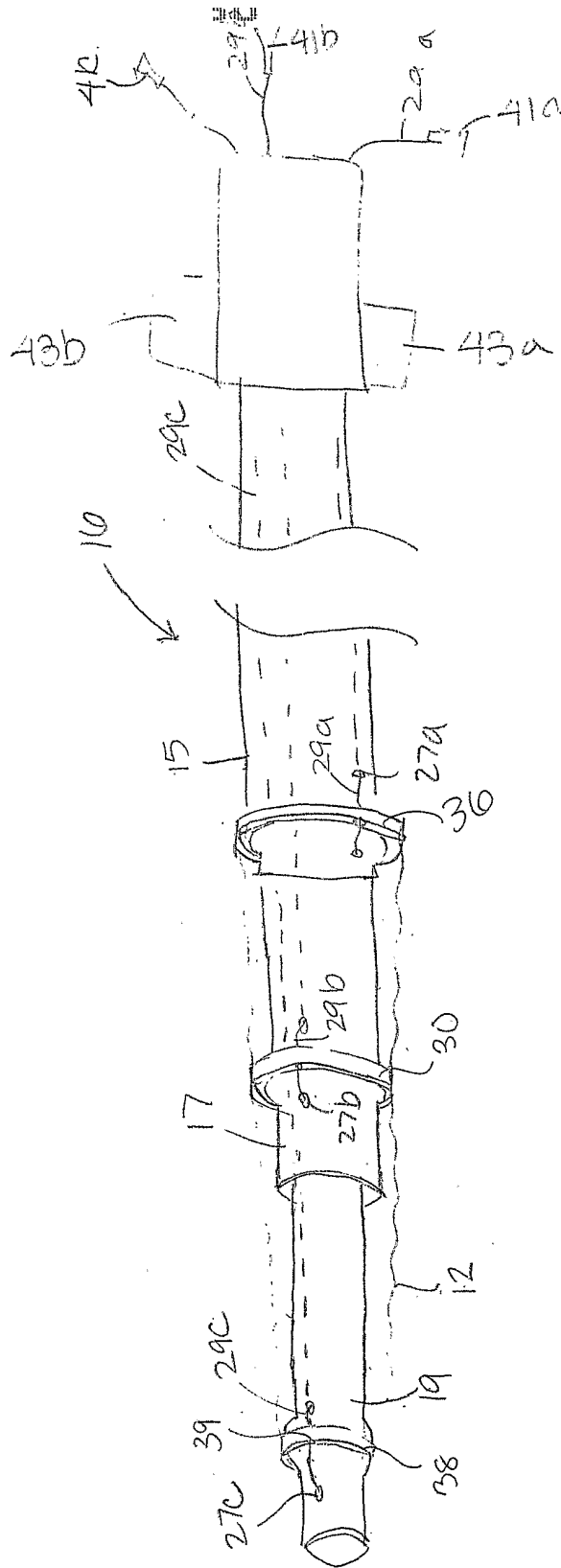

FIG. 10A

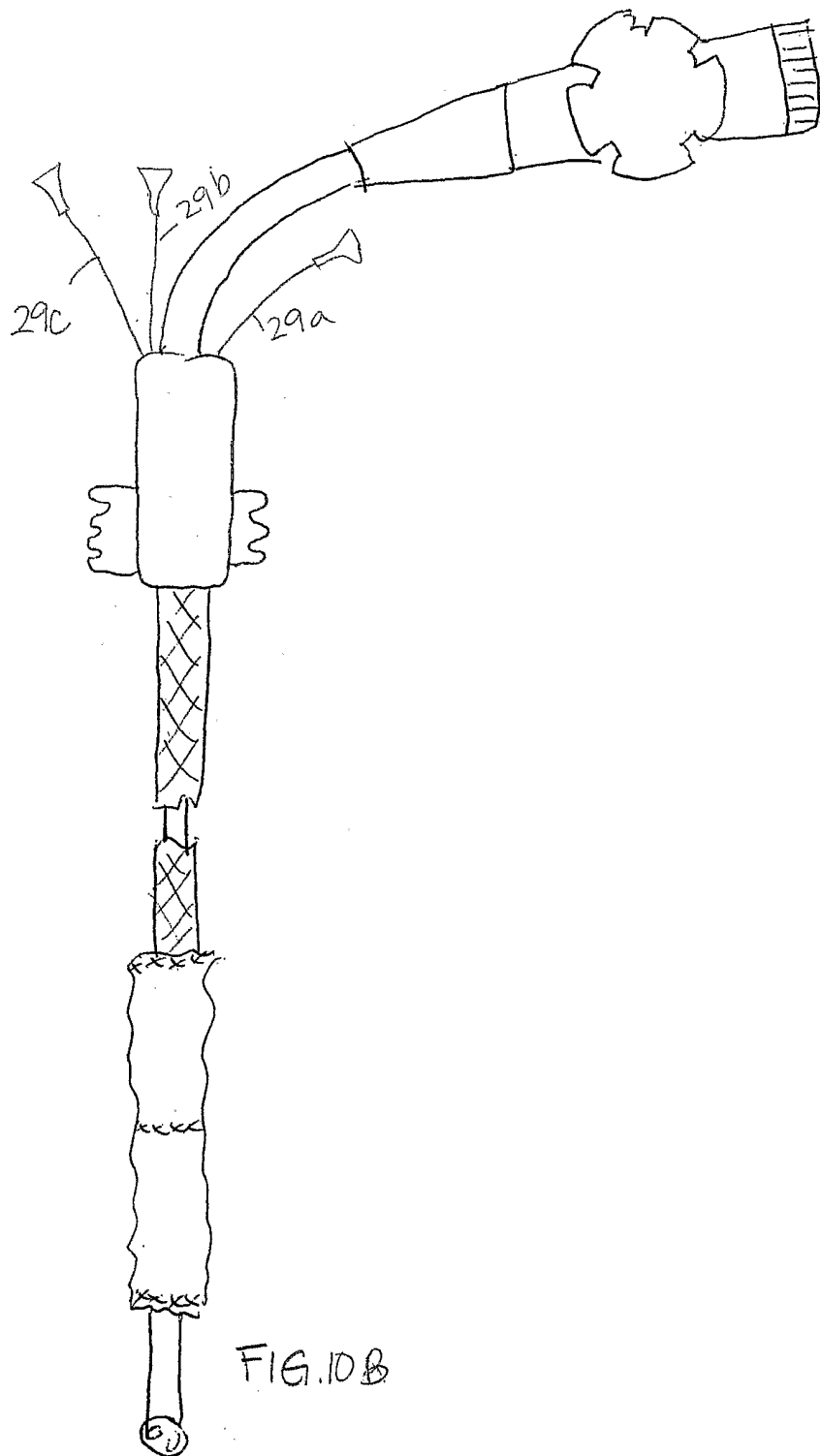

FIG. 10B

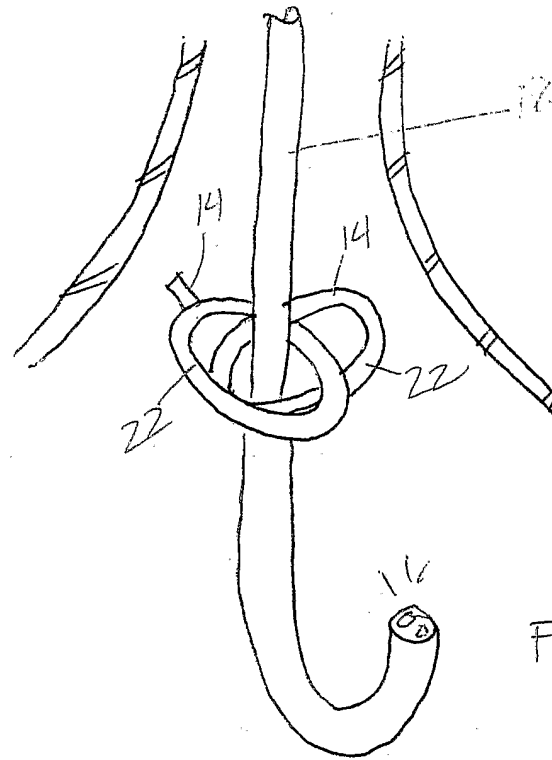

FIG. 10C

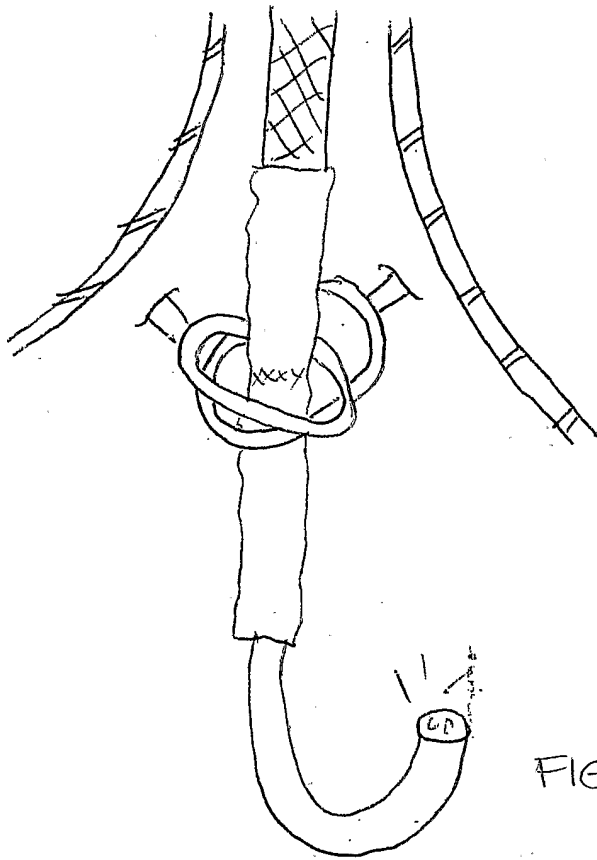

FIG. 10D

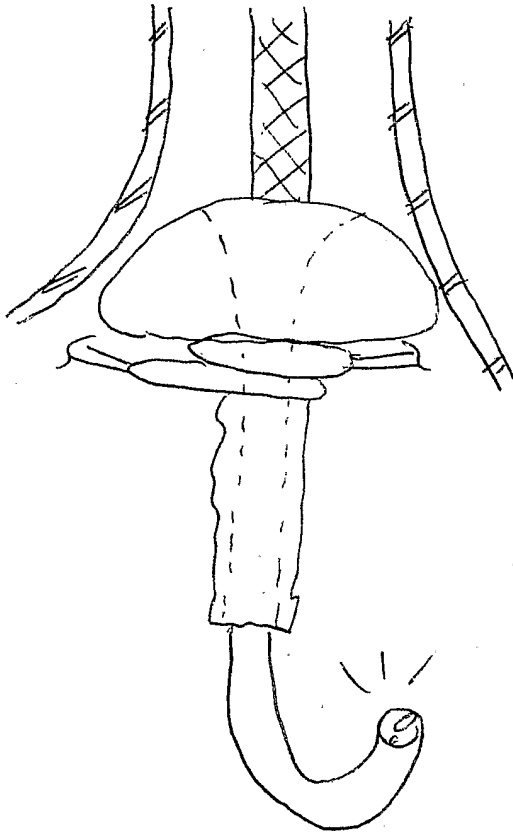

FIG 10E

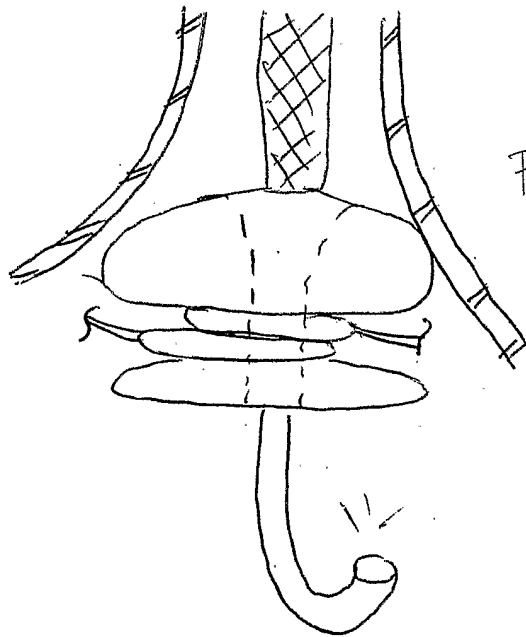

FIG 10F

