



US00D652363S

(12) **United States Design Patent**
Chung

(10) **Patent No.:** **US D652,363 S**

(45) **Date of Patent:** **** Jan. 17, 2012**

(54) **WHEEL**

(75) Inventor: **Suny Chung**, Yorba Linda, CA (US)

(73) Assignee: **Wheel Pros, LLC**, Lakewood, CO (US)

(**) Term: **14 Years**

(21) Appl. No.: **29/359,217**

(22) Filed: **Apr. 7, 2010**

(51) **LOC (9) Cl.** **12-16**

(52) **U.S. Cl.** **D12/211**

(58) **Field of Classification Search** D12/204-213;
301/37.101, 64.101, 65, 64.201

See application file for complete search history.

(56) **References Cited**

U.S. PATENT DOCUMENTS

| | | | | |
|--------------|---------|--------------------|-------|---------|
| D428,846 S * | 8/2000 | Yoshida et al. | | D12/211 |
| D481,663 S * | 11/2003 | Maifirini | | D12/211 |
| D524,217 S * | 7/2006 | Aoki | | D12/211 |
| D533,825 S * | 12/2006 | Baumgartner | | D12/211 |
| D534,473 S * | 1/2007 | Bernoni | | D12/211 |
| D544,822 S * | 6/2007 | Walbey, Jr. et al. | | D12/211 |
| D552,525 S * | 10/2007 | Celik | | D12/211 |
| D580,336 S * | 11/2008 | Chung | | D12/211 |
| D580,841 S * | 11/2008 | Gallert | | D12/211 |
| D605,574 S * | 12/2009 | Abdallah | | D12/211 |
| D626,053 S * | 10/2010 | Groom | | D12/211 |
| D629,733 S * | 12/2010 | Tirado | | D12/211 |
| D638,770 S * | 5/2011 | Chung | | D12/211 |

* cited by examiner

Primary Examiner — Stacia Cadmus

(74) *Attorney, Agent, or Firm* — Garcia-Zamor IP Law; Ruy M. Garcia-Zamor

(57) **CLAIM**

The ornamental design for a wheel, as shown and described.

DESCRIPTION

FIG. 1 is a perspective view of a wheel showing my new design;

FIG. 2 is a front elevational view of the wheel of FIG. 1;

FIG. 3 is a left side elevational view of the wheel of FIG. 1, the right side elevational view of the wheel of FIG. 1 is a mirror image of FIG. 3;

FIG. 4 is a top plan view of the wheel of FIG. 1;

FIG. 5 is a bottom plan view of the wheel of FIG. 1;

FIG. 6 is a rear elevational view of the wheel of FIG. 1;

FIG. 7 is a perspective view of a wheel according to a second preferred embodiment of my new design;

FIG. 8 is a front elevational view of the wheel of FIG. 7;

FIG. 9 is a left side elevational view of the wheel of FIG. 7, the right side elevational view of the wheel of FIG. 7 is a mirror image of FIG. 9;

FIG. 10 is a top plan view of the wheel of FIG. 7;

FIG. 11 is a bottom plan view of the wheel of FIG. 7; and,

FIG. 12 is a rear elevational view of the wheel of FIG. 7.

The broken lines in FIGS. 1-12 represent environment and are for illustrative purposes only and do not constitute part of the claimed design.

1 Claim, 10 Drawing Sheets

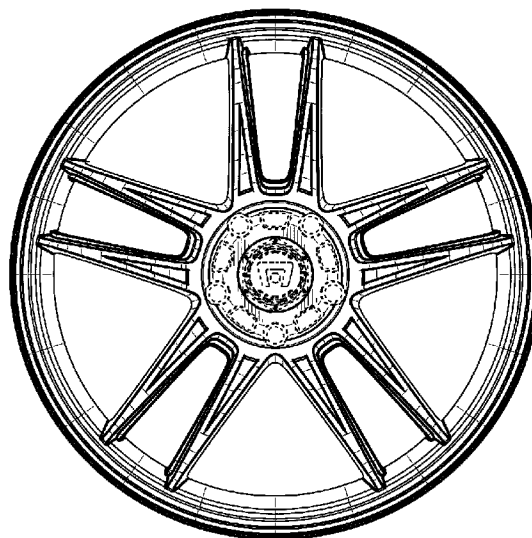
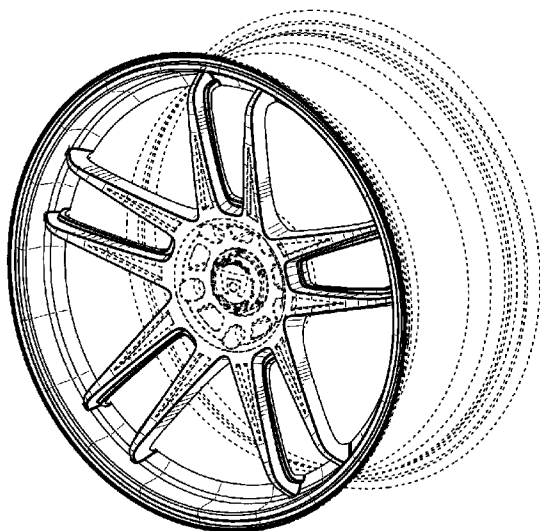

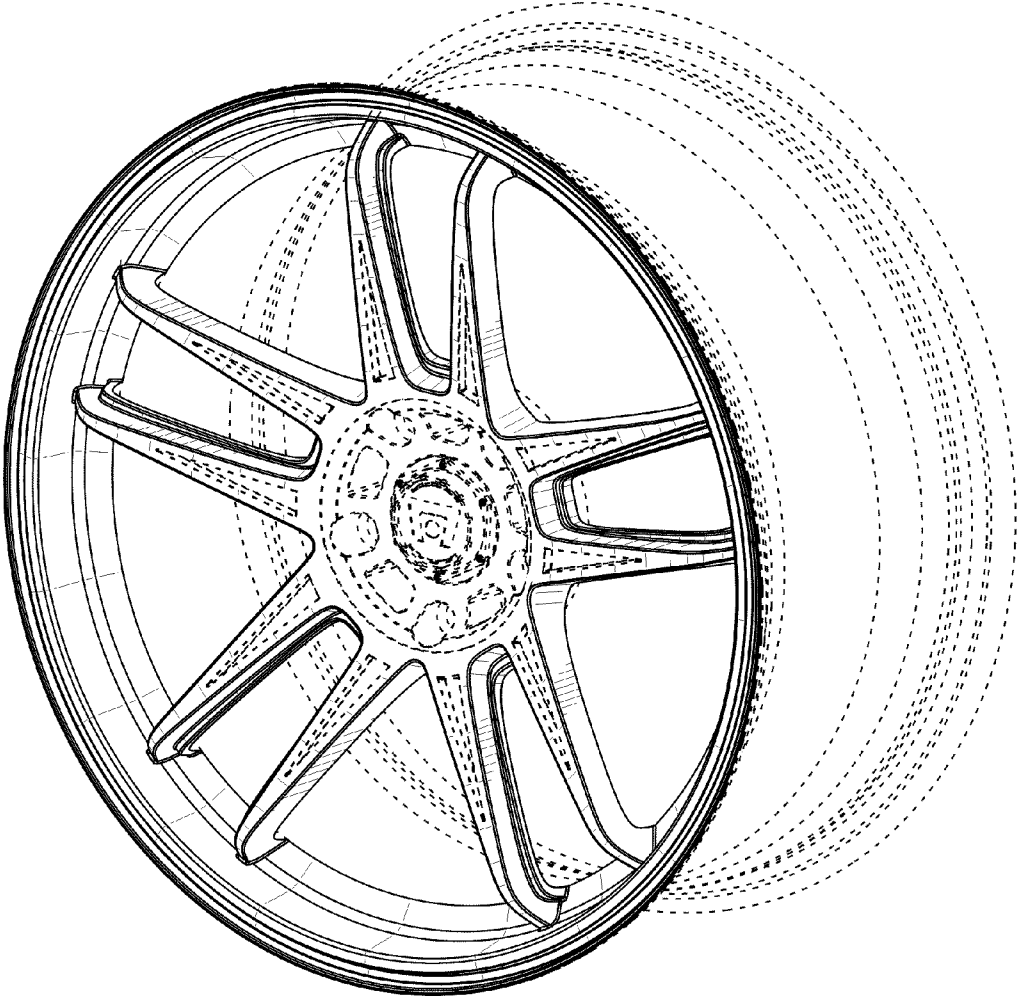

FIG. 1

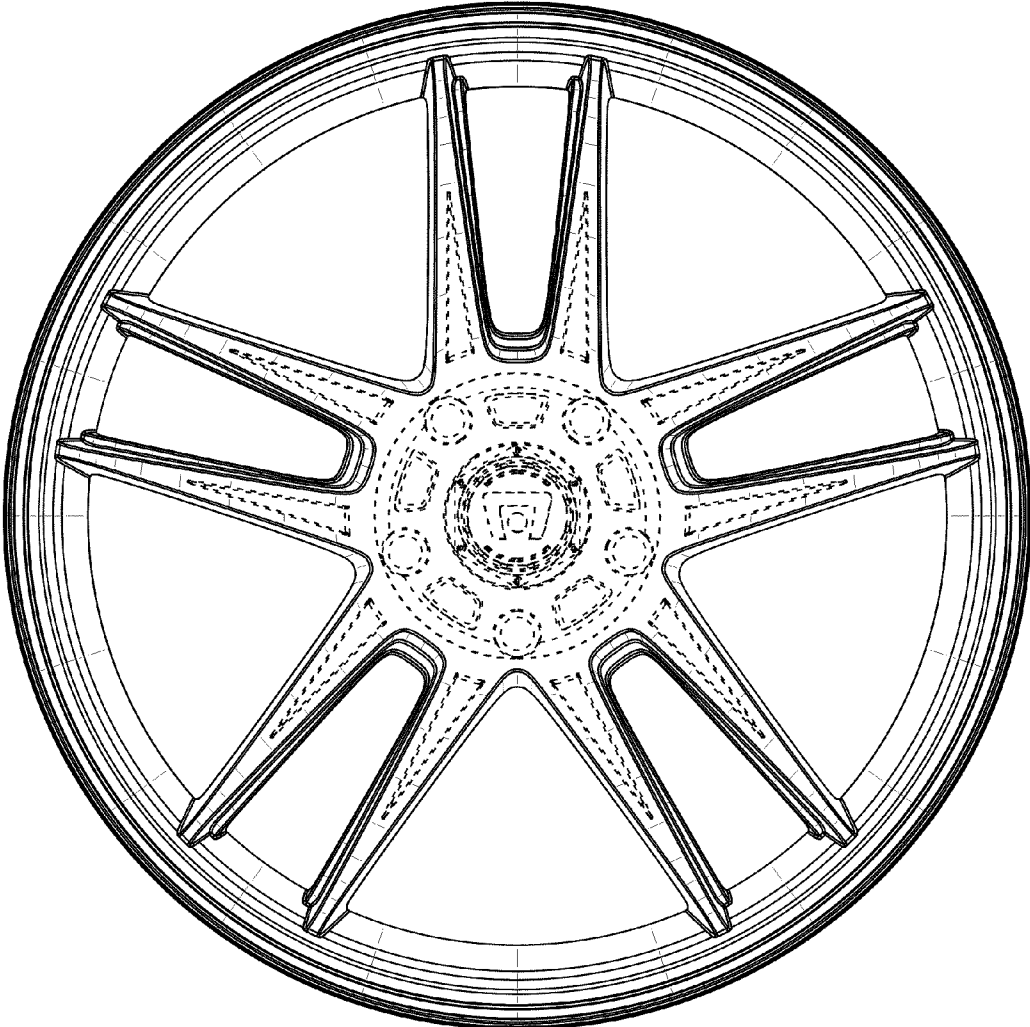

FIG. 2

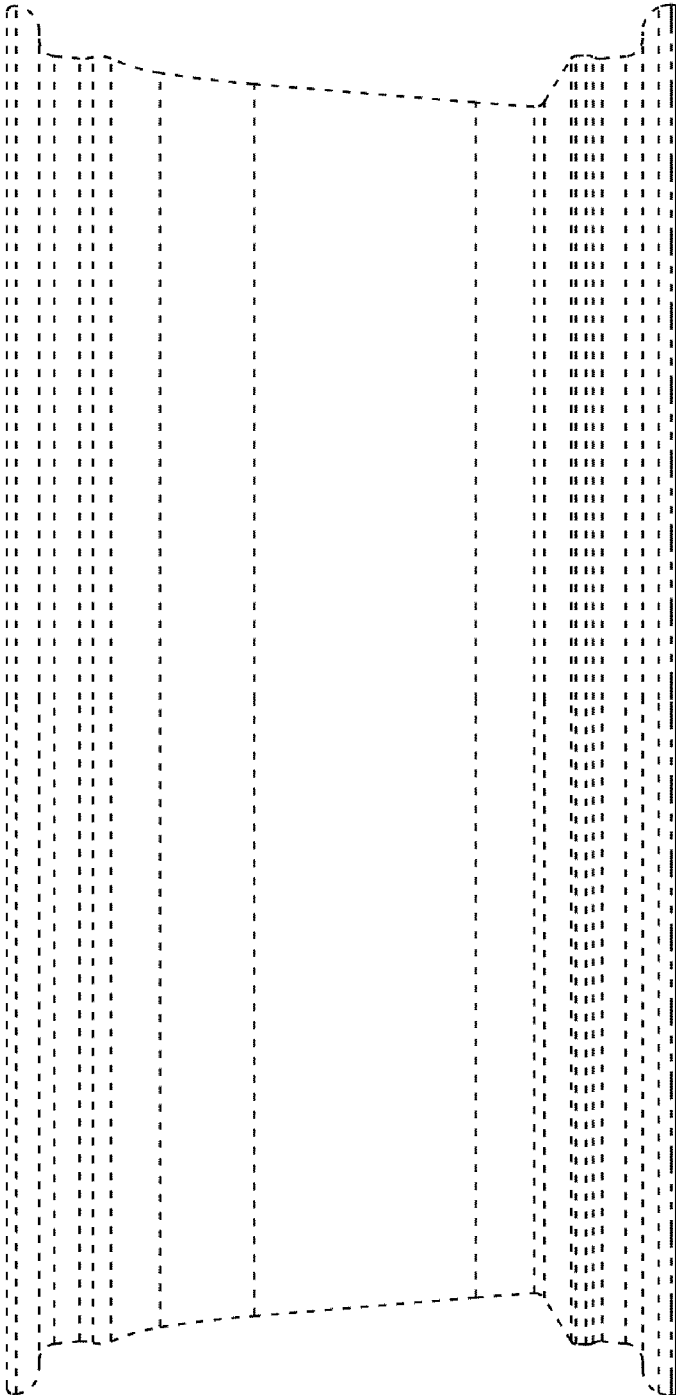

FIG. 3

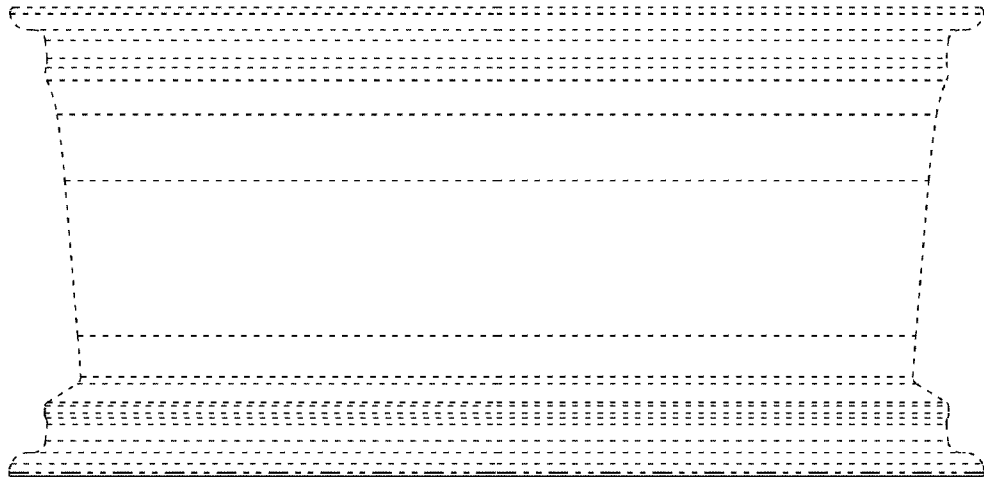

FIG. 4

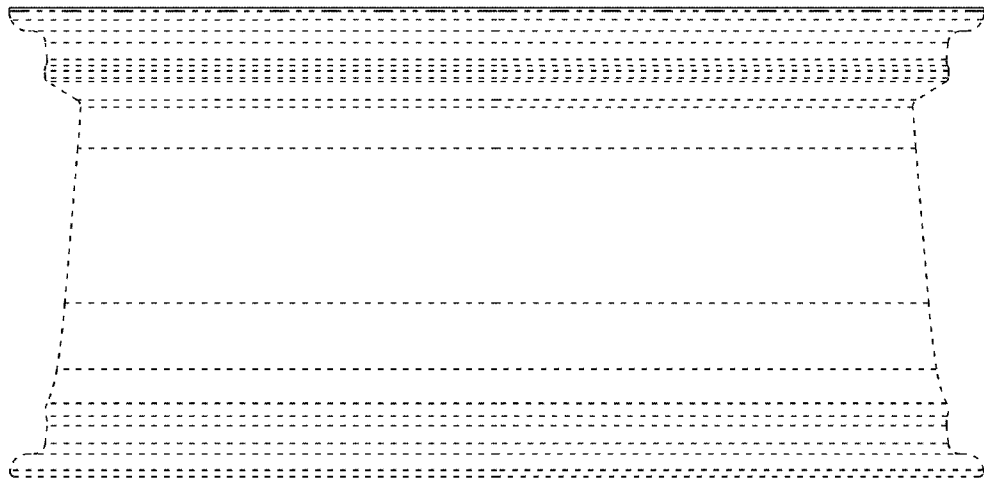

FIG. 5

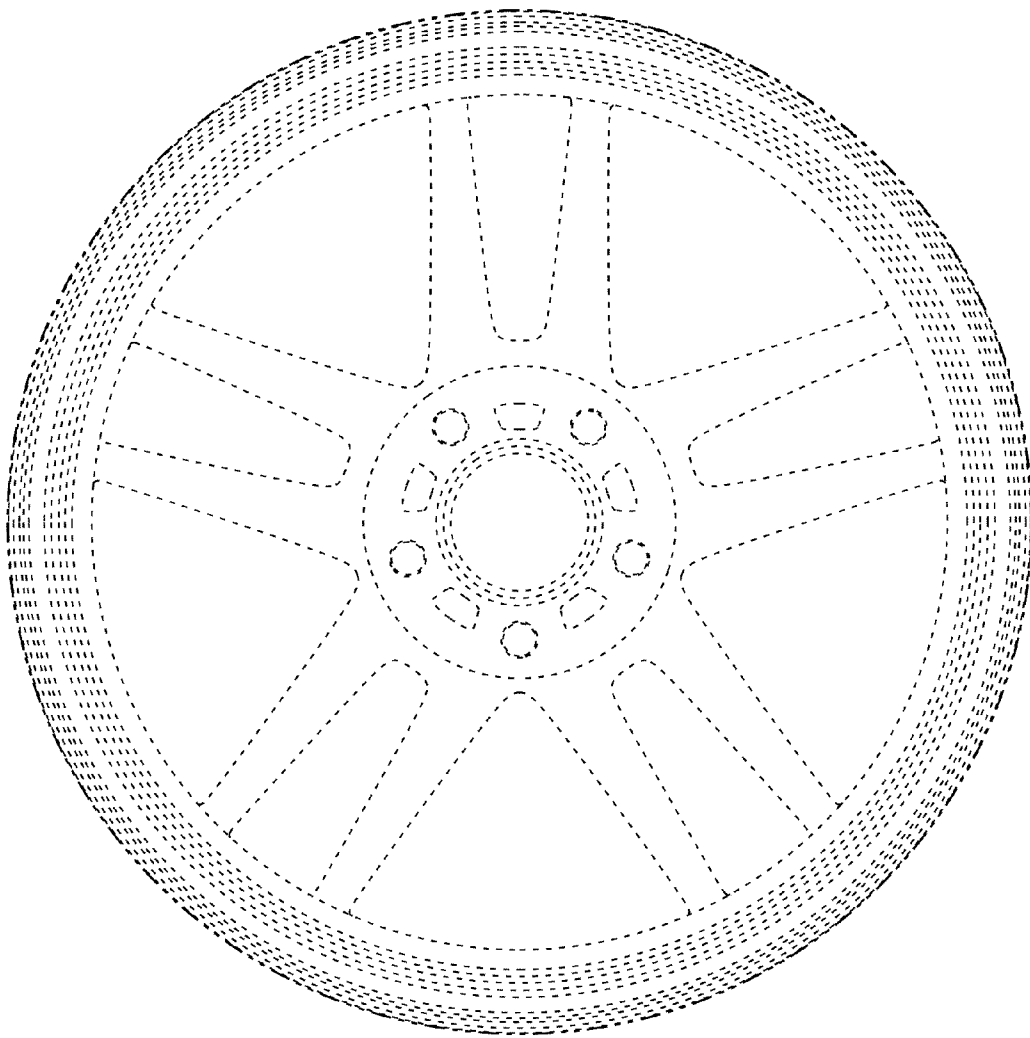

FIG. 6

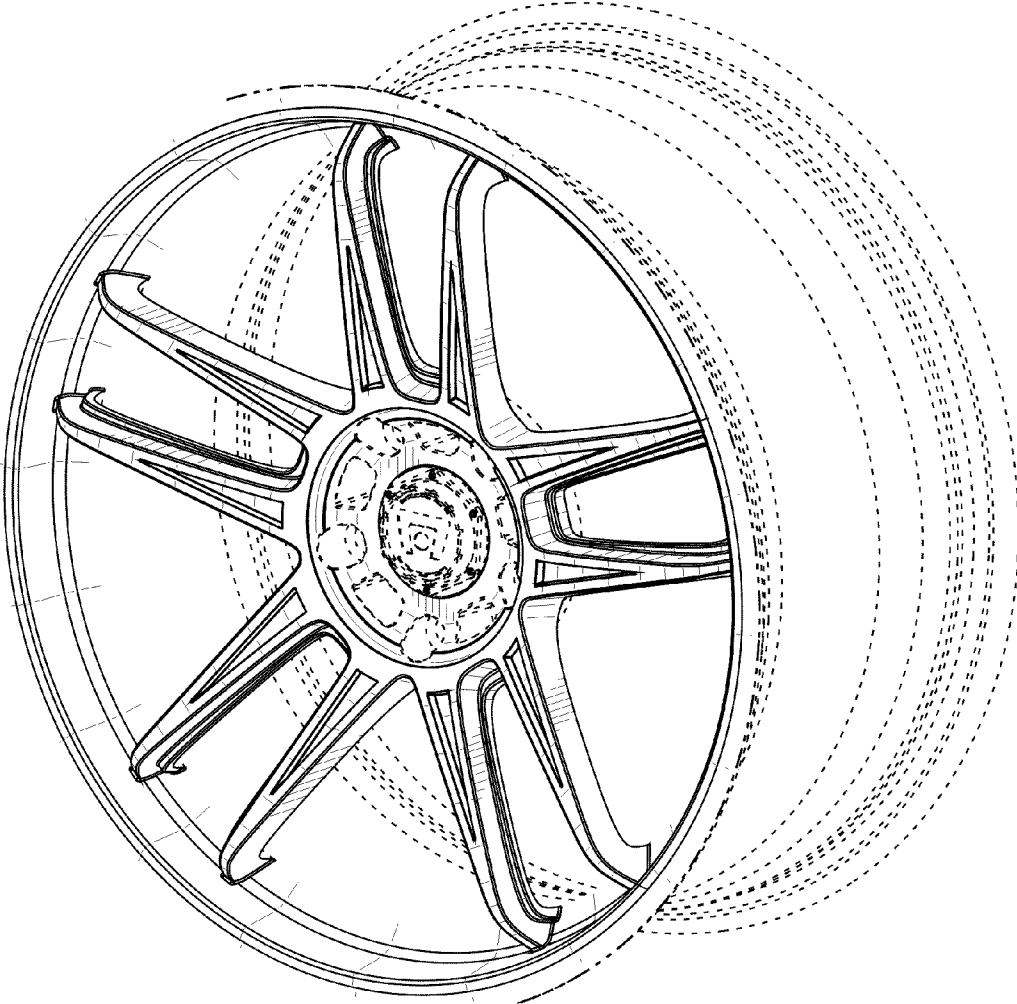

FIG. 7

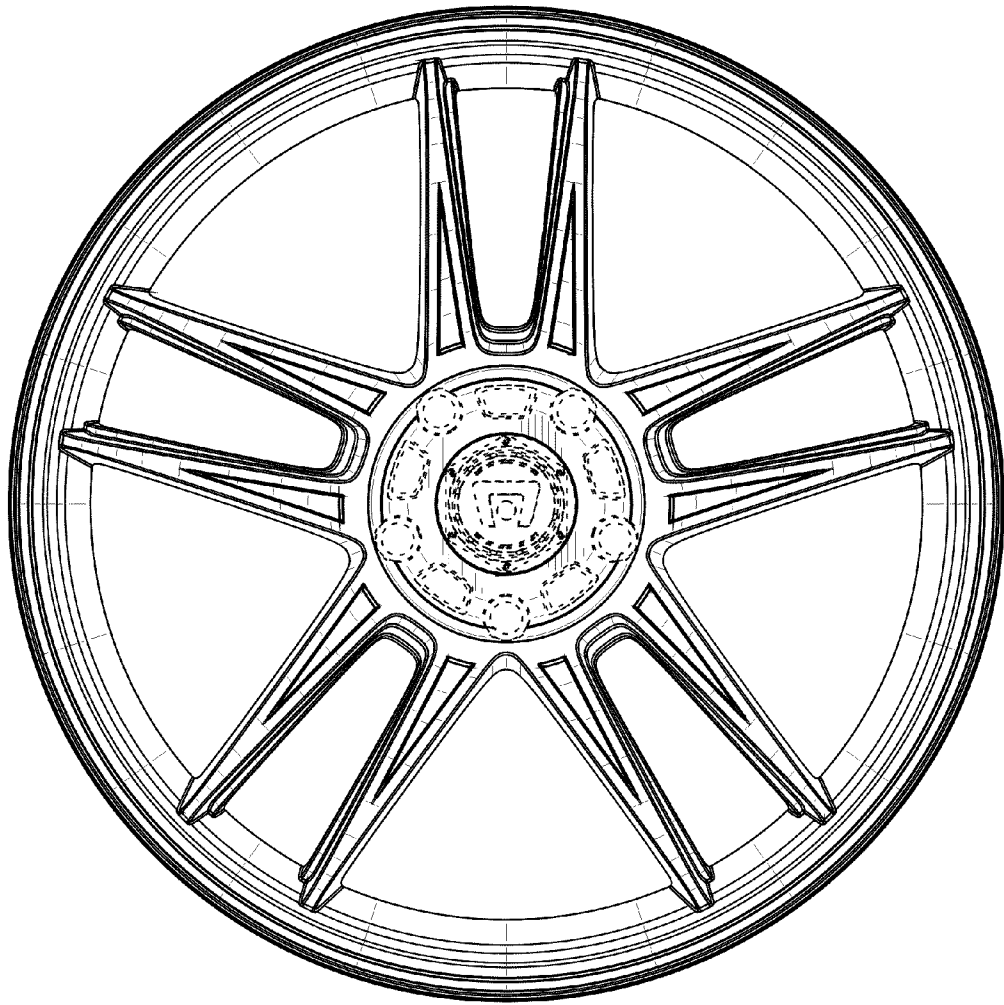

FIG. 8

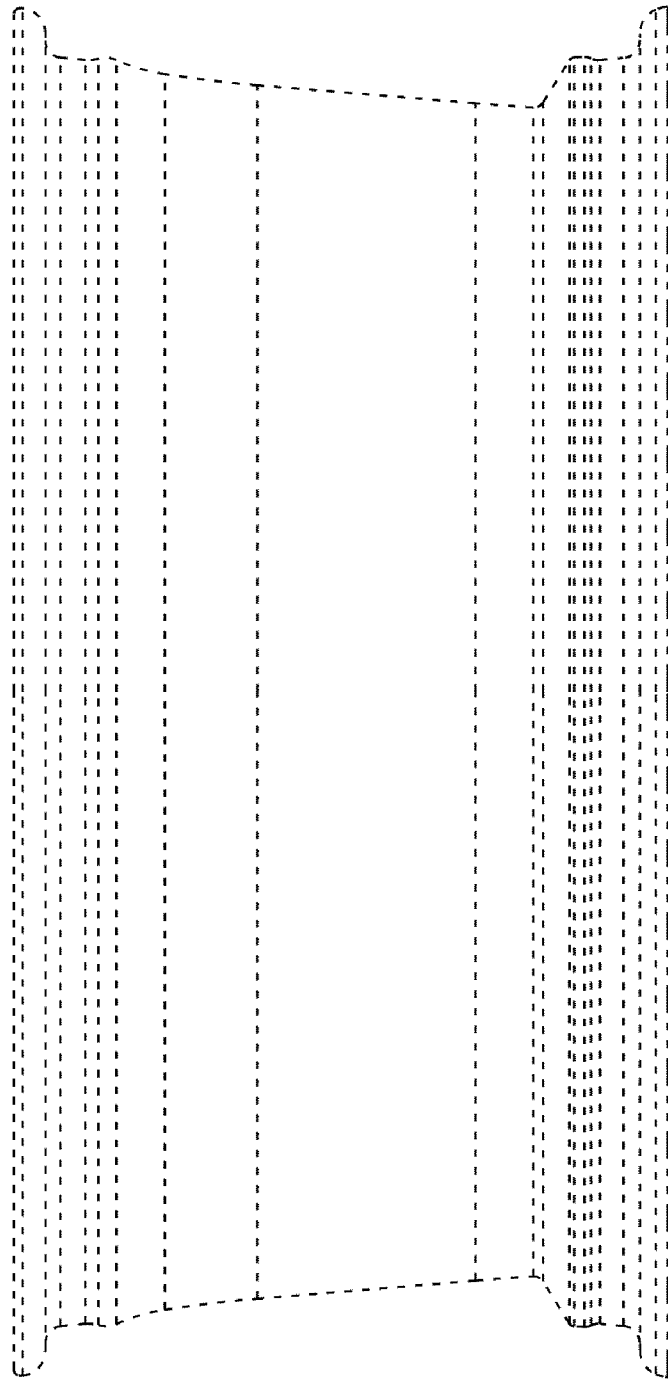

FIG. 9

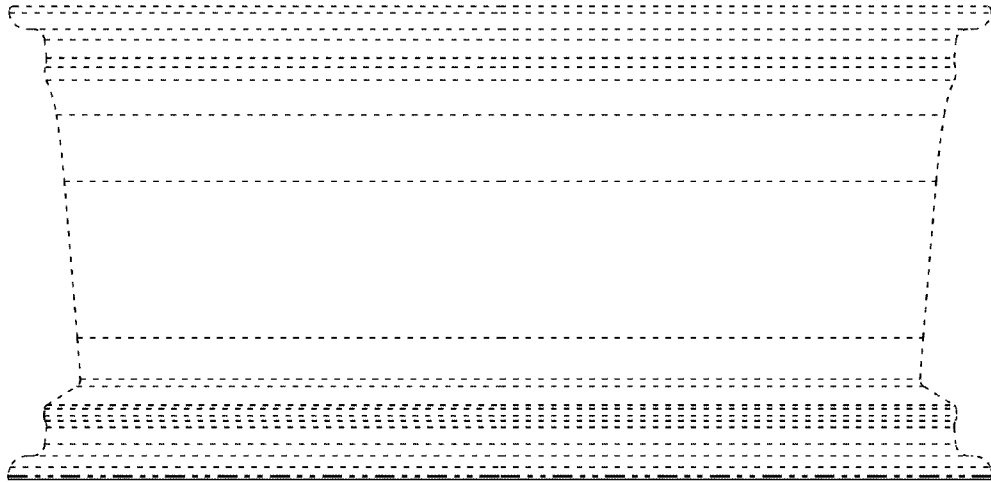

FIG. 10

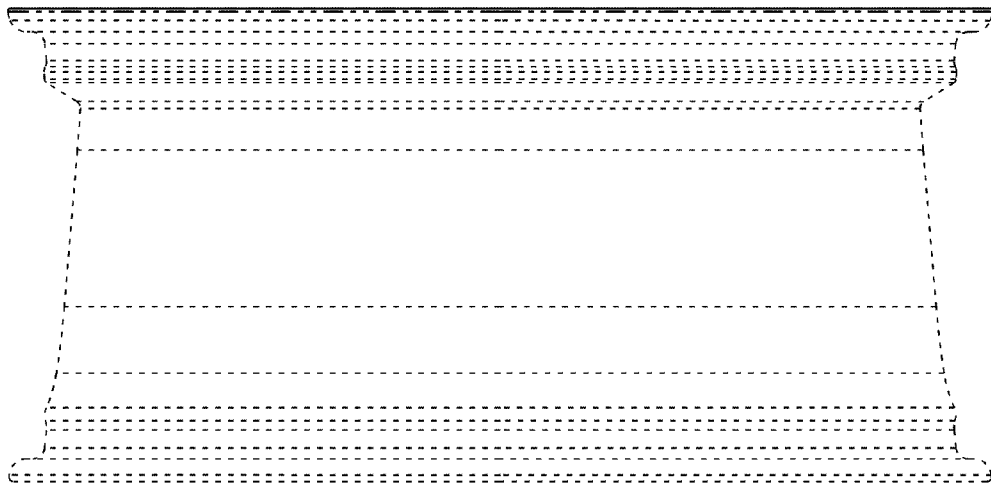

FIG. 11

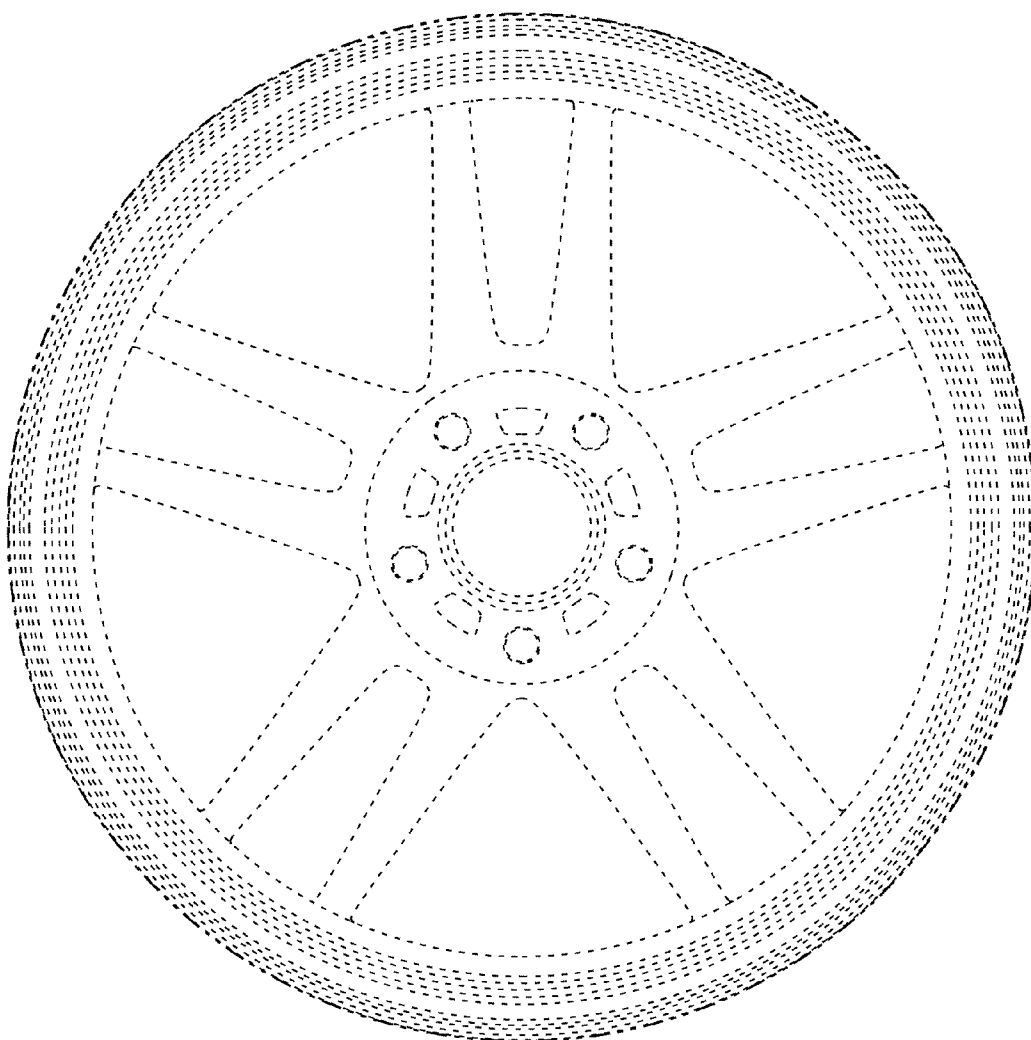

FIG. 12