

Sept. 2, 1958

B. G. SIMMONS

2,849,874

STRUCTURAL BLOCK JOINT

Filed Sept. 26, 1955

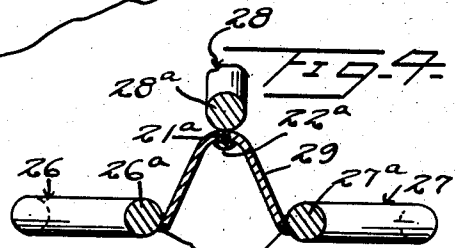
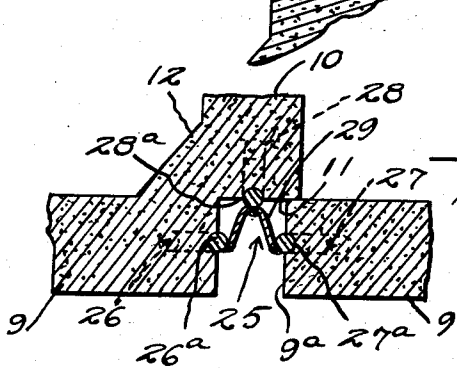
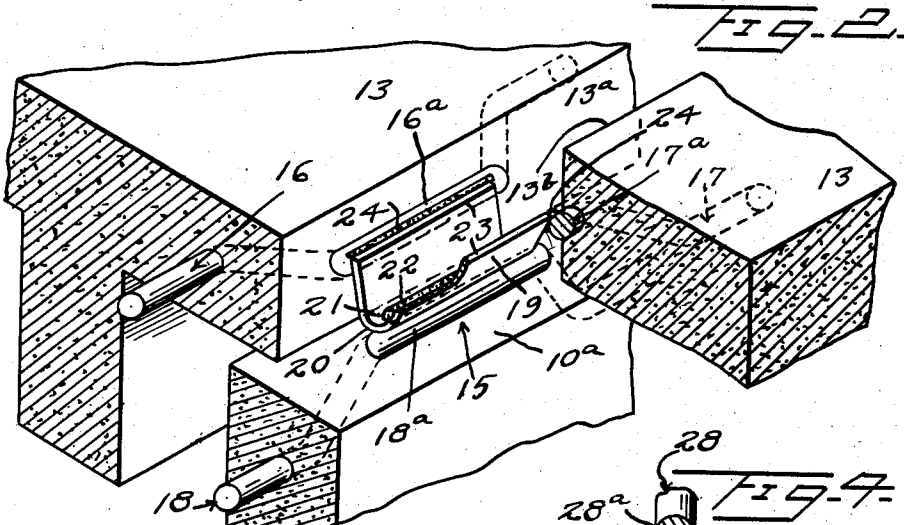
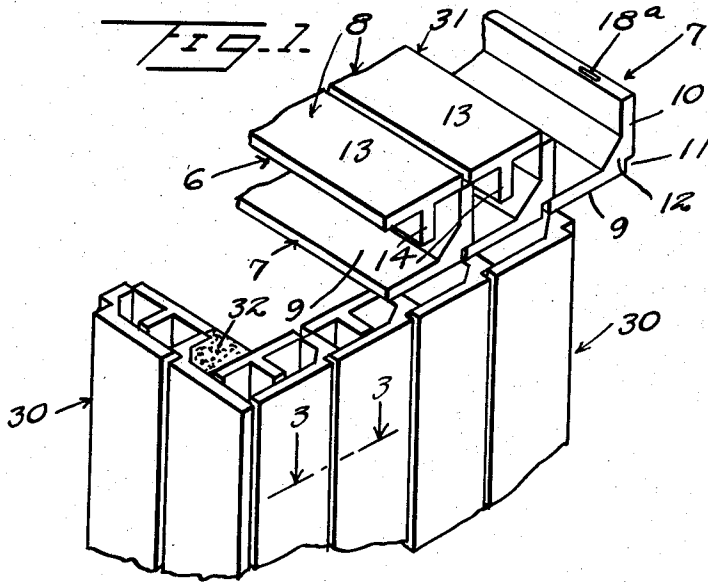

INVENTOR

B.G. Simmons

BY John N. Randolph

ATTORNEY

1

2,849,874

STRUCTURAL BLOCK JOINT

Bowie G. Simmons, Mobile, Ala.

Application September 26, 1955, Serial No. 536,659

1 Claim. (Cl. 72-107)

This invention relates to a precast concrete structural unit formed of sections, a plurality of which units are capable of being readily assembled to provide a hollow concrete wall, floor, ceiling or roof.

Another object of the invention is to provide a precast structural unit including novel means for anchoring the individual sections of each unit together and for anchoring or connecting adjacent units to form a wall, floor, ceiling or roof.

A further object of the invention is to provide anchoring or connecting means which are so constructed as to permit relative expansion and contraction of the individual units and sections and to compensate for irregularities in adjacent edges thereof.

Various other objects and advantages of the invention will hereinafter become more fully apparent from the following description of the drawing, illustrating a presently preferred embodiment thereof, and wherein:

Figure 1 is a fragmentary perspective view in elevation showing a plurality of the structural units assembled to form parts of walls and a part of a floor, ceiling or roof;

Figure 2 is an enlarged fragmentary perspective view in section illustrating details of sections of the structural units;

Figure 3 is an enlarged cross sectional view taken substantially along a plane as indicated by the line 3-3 of Figure 1, and

Figure 4 is an enlarged cross sectional view of the connecting means, as shown in Figure 3, removed from the concrete sections.

Referring more specifically to the drawing, the structural unit comprising the invention is designated generally 6 and is composed of a precast concrete section 7 and a precast concrete section 8.

The concrete section 7 is of angular shape in cross section and is composed of the sides 9 and 10 which form a right angle with one another. The section 7 is provided with a notch 11 of right angular cross section formed in the outer corner of the sides 9 and 10 and which extends from end-to-end of said angular section 7. The inner side of the corner formed by the sides or walls 9 and 10 is thickened as seen at 12, opposite to the notch 11, so that the corner of the section 7 is not weakened by the notch 11.

The section 8 of each structural unit 6 is of T-shaped cross section and comprises a bar portion 13 and a web 14. Said web 14 projects perpendicularly from one side of the bar 13 and is spaced midway between the longitudinal edges thereof and extends from end-to-end of said bar.

The sections 7 and 8 are provided with anchoring units, designated generally 15, and illustrated in Figures 2, 3 and 4. The anchoring or connecting units 15 comprise rods 16, 17 and 18 and a connecting plate 19. The rods 16 and 17 are anchored in complementary portions of the bars 13 adjacent longitudinal edges thereof and have intermediate portions 16a and 17a which are offset relative to the end portions of said rods and which are outwardly

2

offset relative to the longitudinal edges 13a and 13b of the bars 13, so that said intermediate rod portions 16a and 17a are exposed. Similarly, the rod 18 is anchored in the side 10 and has its offset intermediate portion 18a disposed outwardly with respect to the longitudinal edge 10a, which is located remote from the notch 11, and so as to be disposed in an exposed position. It will be understood that the rods 16, 17 and 18 of each anchoring or connecting unit 15 are disposed corresponding distances from complementary ends of the sections 7 and 8 and that any number of said connecting units may be provided along the lengths of said sections. The plate 19 is of substantially V-shaped cross section and has a rounded intermediate portion 20 provided with a plurality of slots or elongated openings 21. Said intermediate portion 20 is adapted to rest upon the rod portion 18a and is secured thereto by welding as seen at 22 through the slots or openings 21. The longitudinal edges 23 of the plate 19 bear against the rod portions 16a and 17a, as seen in Figure 2, and are secured thereto by welding, as seen at 24. Thus, the sections 7 and 8 of a structural unit 6 are connected together by the parts 16, 18 and 19 of each connecting unit 15 and the sections 8 of adjacent units 6 are connected by the parts 16 and 17 and the plate 19. The connecting unit 15 also connects the section 7 of the unit 6 to the section 8 of an adjacent unit 6 by the parts 17, 18 and 19 thereof, all as clearly illustrated in Figure 2.

Connecting units 25, corresponding to the units 15, are provided for connecting the sections 7 of adjacent units 6. As best illustrated in Figure 3, the rod 26, corresponding to the rod 16, is anchored in the wall 9 of a section 7 and has its offset intermediate portion 26a exposed in the notch 11 of said section. The rod 28 is embedded and anchored in the lower part of the wall or side 10 and has its intermediate portion 28a partially exposed in the notch 11. A rod 27, corresponding to the rod 17, is anchored in the side 9 of an adjacent section 7 and has its intermediate portion 27a protruding from the longitudinal edge 9a, which is disposed remote from the notch 11 of said last mentioned wall 9. The plate 29, corresponding to the plate 19, is assembled in the same manner with the rod portions 26a, 27a and 28a, as the plate 19 is assembled with the rod portions 16a, 17a and 18a, respectively. However, since the rod 28, corresponding to the rod 18, is disposed above relative than below the plane of the rods 26 and 27, the plate 29 is disposed in an inverted position as illustrated in Figures 3 and 4.

Figure 4 clearly illustrates the slots or openings 21a in the intermediate portion of the plate 29 to receive the welds 22a by which the intermediate portion of said plate 29 is secured to the rod portion 28a. Figure 4 also clearly shows the longitudinal edges of the plate 29 secured by the welds 24a to the rod portions 26a and 27a.

It will thus be readily apparent that the connecting units 15 and 25 will effectively function for connecting the sections 6 and 7 together as previously described to form walls as seen at 30 or a floor, ceiling or roof, as seen at 31 in Figure 1. Either of the sections 7 and 8 may constitute either the upper or the lower parts of the horizontal structural member 31 or the inner or the outer parts of the vertical structural member 30. It will also be understood that after the sections have been assembled the connecting plates 19 and 29 are applied and are welded to the rod portions to which said plates are anchored.

The sides 10 are of sufficient thickness so that the edges 13a and 13b of adjacent sections 8 may substantially overlie the sides of the wall 10 so that the bar portions 10 will have adequate support on the upper edge 10a. However the edges 13a and 13b are still spaced a substan-

tial distance apart to provide an open joint so that any irregularities therein will not interfere with assembly of the structural units 6. Similarly, as illustrated in Figure 3, edge portions 9a of the sides 9 extend substantially into the notches 11 so that the sides 9 provide substantial supports for the sides 10 of adjacent sections while still leaving an open joint of considerable width. These open joints of the notches 11 and between the edges 13a and 13b may be filled with a suitable expansion joint material such as mortar, cement or plaster, not shown. Since the connecting plates 19 and 29 are capable of yielding, the joints in which said members are disposed may be expanded or restricted in response to contraction or expansion of the sections 7 and 8.

The web 14 of each unit 6 is of a height substantially less than that of the wall 10 so that said web does not contact any part of the section 7 but rather is merely utilized to provide beam strength for the bar portion 13, and the dimensions of said web may vary depending upon the area spanned and the load to be sustained by the bar portion. Thus, when the units 6 are disposed horizontally, the sides 10 will alone sustain the load borne by said units. The relative widths of the sides 9 and 10 of the sections 7 may likewise be varied.

The gap left in the corner formed by the two vertical walls 30, as seen in Figure 1, may be filled with a suitable filler material 32.

Various modifications and changes are contemplated and may obviously be resorted to, without departing from the spirit or scope of the invention as hereinafter defined by the appended claim.

I claim as my invention:

In combination with two substantially coplanar wall portions having opposed adjacent edges disposed in spaced apart relation to one another and a third wall portion disposed at substantially a right angle to the plane of said two wall portions and having an edge disposed adjacent the gap between said adjacent edges and combining therewith to form an open joint; a connecting unit comprising rods associated with and having end portions embedded and anchored in said wall portions, said rods having exposed intermediate parts spaced outwardly from said edges of the wall portions and disposed in said open joint and relative to one another to form a triangle with two of said exposed parts positioned in opposed relation to one another, and a plate of substantially V-shaped cross section having sides secured to said opposed intermediate parts and an intermediate portion secured to the other intermediate part for connecting said rods and the wall portions together, said plate being yieldable to accommodate contraction and expansion of the open joint.

References Cited in the file of this patent

UNITED STATES PATENTS

1,420,020	Ceriat	June 20, 1922
1,998,448	Crowe	Apr. 23, 1935
2,154,619	Hurley	Apr. 18, 1939

FOREIGN PATENTS

9,689	Great Britain	Apr. 24, 1913
608,744	France	Apr. 30, 1926