



US00D740095S

(12) **United States Design Patent**  
**Battenfeld**

(10) **Patent No.:** **US D740,095 S**

(45) **Date of Patent:** **\*\* Oct. 6, 2015**

(54) **CRIMPING PLIERS**

(71) Applicant: **WEZAG GmbH Werkzeugfabrik,**  
Stadtallendorf (DE)

(72) Inventor: **Kurt Battenfeld,**  
Ebsdorfergrund/Wittelsberg (DE)

(73) Assignee: **WEZAG GMBH**  
**WERKZEUGFABRIK,** Stadtallendorf  
(DE)

(\*\*) Term: **14 Years**

(21) Appl. No.: **29/447,162**

(22) Filed: **Mar. 1, 2013**

**Related U.S. Application Data**

(63) Continuation of application No. 29/438,937, filed on  
Dec. 5, 2012, and a continuation of application No.  
29/438,940, filed on Dec. 5, 2012, and a continuation  
of application No. 29/438,942, filed on Dec. 5, 2012.

(30) **Foreign Application Priority Data**

Jun. 5, 2012 (EP) ..... 002052555

(51) **LOC (10) Cl.** ..... **08-05**

(52) **U.S. Cl.**  
USPC ..... **D8/52**

(58) **Field of Classification Search**

USPC ..... D8/60, 51, 52, 54, 59, 32; 72/370.12,  
72/316-322, 300, 352, 381, 409.16,  
72/409.13, 409.1; 29/268, 270, 750, 751,  
29/753, 566.4; 81/421; 7/107; 30/91.2,  
30/134, 90.1

CPC . H02G 1/1202; H02G 1/1204; H02G 1/1234;  
H02G 1/1212

See application file for complete search history.

(56) **References Cited**

**U.S. PATENT DOCUMENTS**

5,913,933 A \* 6/1999 Beetz et al. .... 72/409.16  
6,026,671 A \* 2/2000 Battenfeld ..... 72/409.12

(Continued)

*Primary Examiner* — Ian Simmons

*Assistant Examiner* — Harold Blackwell, II

(74) *Attorney, Agent, or Firm* — Thomas | Horstemeyer,  
LLP

(57) **CLAIM**

The ornamental design of crimping pliers, as shown and  
described.

**DESCRIPTION**

FIG. 1 is a perspective view showing my new crimping pliers  
with opened handle and for an additional actuation mecha-  
nism at the top of the pliers head in an open state;

FIG. 2 is a front side view thereof;

FIG. 3 is a right side view thereof;

FIG. 4 is a rear view thereof;

FIG. 5 is a left side view thereof;

FIG. 6 is a top view thereof;

FIG. 7 is the bottom view thereof;

FIG. 8 is a perspective view showing my new crimping pliers,  
wherein the handles are in an open operating state and the  
additional actuation mechanism is in a closed state;

FIG. 9 is a front side view thereof;

FIG. 10 is a right side view thereof;

FIG. 11 is a rear view thereof;

FIG. 12 is a left side view thereof;

FIG. 13 is a top view thereof;

FIG. 14 is the bottom view thereof;

FIG. 15 is a perspective view showing my new crimping  
pliers, wherein the handles are in a closed operating state and  
the additional actuation mechanism is in an open state;

FIG. 16 is a front side view thereof;

FIG. 17 is a right side view thereof;

FIG. 18 is a rear view thereof;

FIG. 19 is a left side view thereof;

FIG. 20 is a top view thereof; and,

FIG. 21 is the bottom view thereof.

The broken lines illustrate portions of the crimping pliers  
which form no part of the claimed design.

**1 Claim, 21 Drawing Sheets**

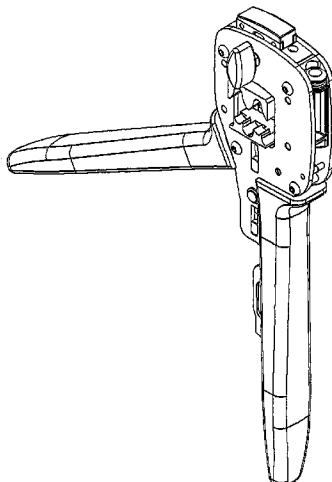

(56)

**References Cited**

U.S. PATENT DOCUMENTS

D544,323	S	*	6/2007	Hutchfield	.....	D8/52	D693,198	S	*	11/2013	Hutchfield et al.	.....	D8/51
8,230,715	B2	*	7/2012	Battenfeld et al.	.....	72/409.16	2009/0044410	A1	*	2/2009	Battenfeld	.....	30/91.2
D693,196	S	*	11/2013	Hutchfield et al.	.....	D8/51	2009/0183547	A1	*	7/2009	Battenfeld et al.	.....	72/409.12
D693,197	S	*	11/2013	Hutchfield et al.	.....	D8/51	2009/0217791	A1	*	9/2009	Battenfeld et al.	.....	81/421
							2009/0249855	A1	*	10/2009	Battenfeld et al.	.....	72/409.13
							2011/0072593	A1	*	3/2011	Battenfeld et al.	.....	7/107

\* cited by examiner

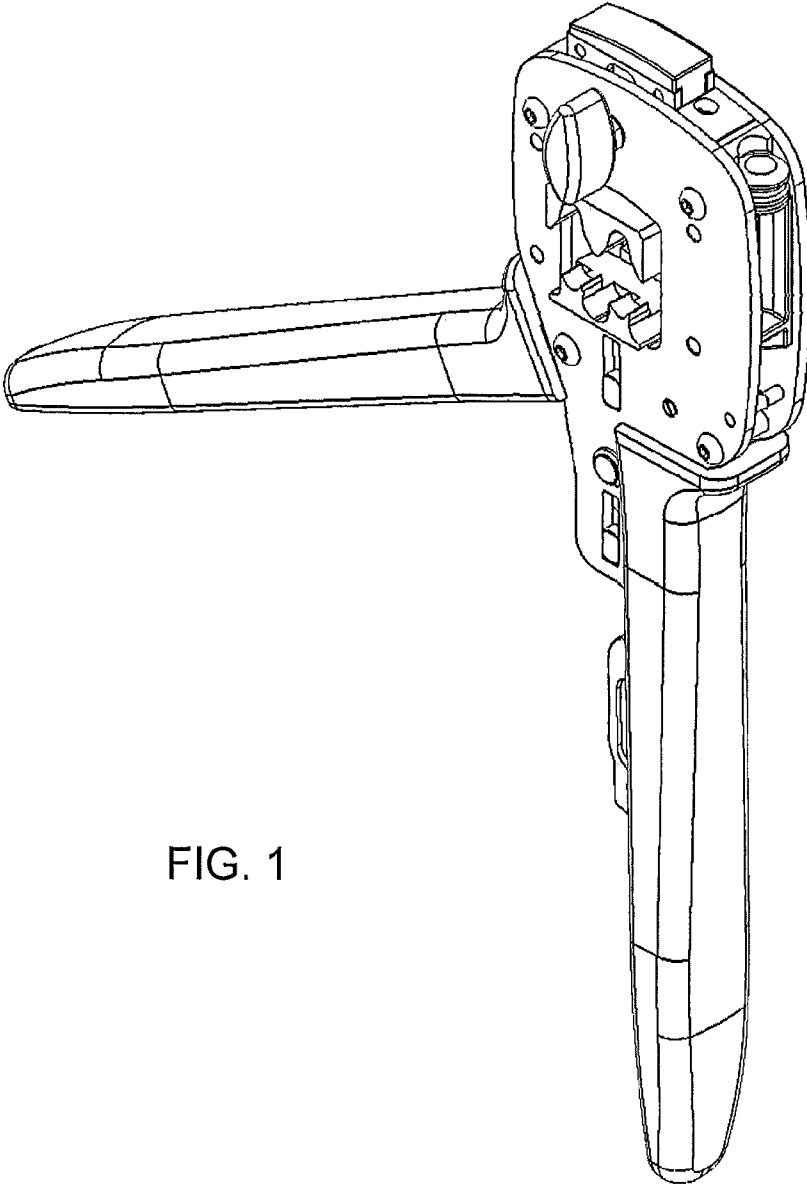

FIG. 1

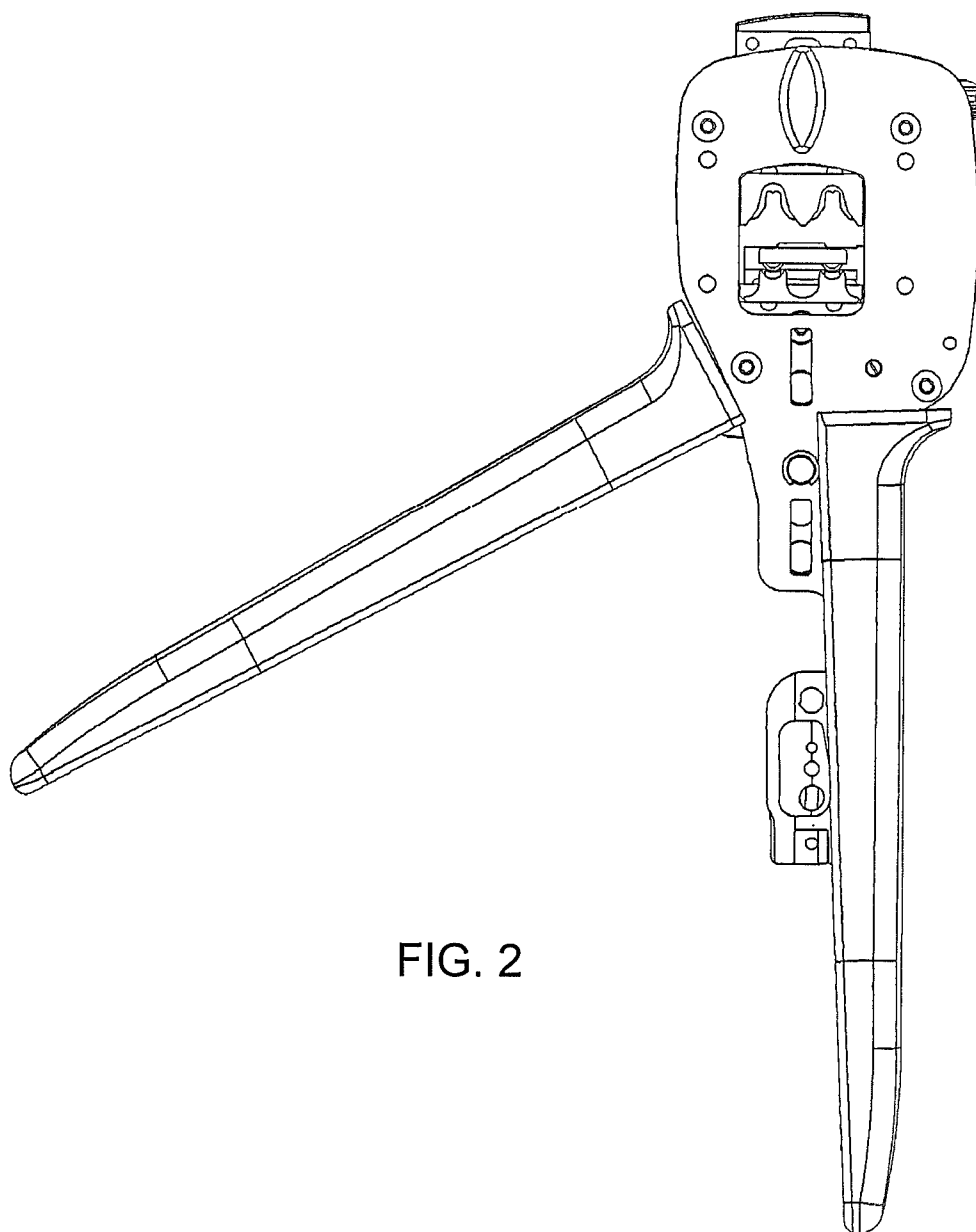

FIG. 2

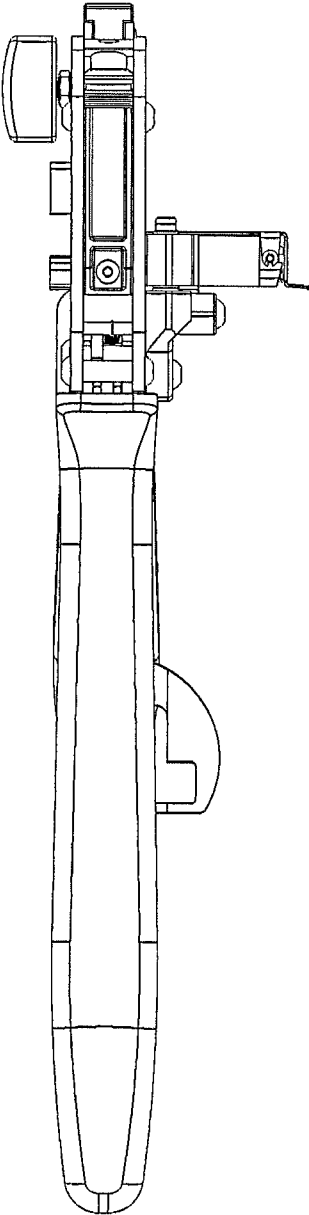

FIG. 3

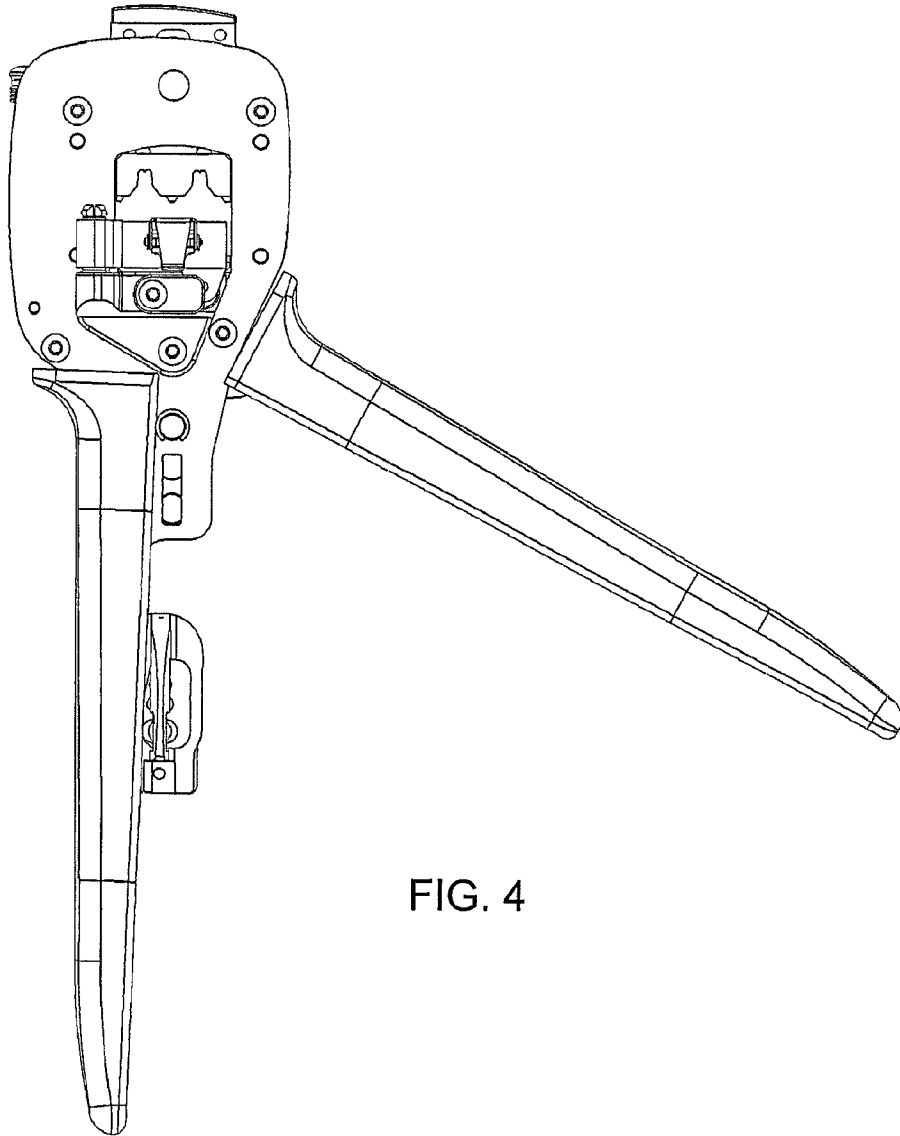

FIG. 4

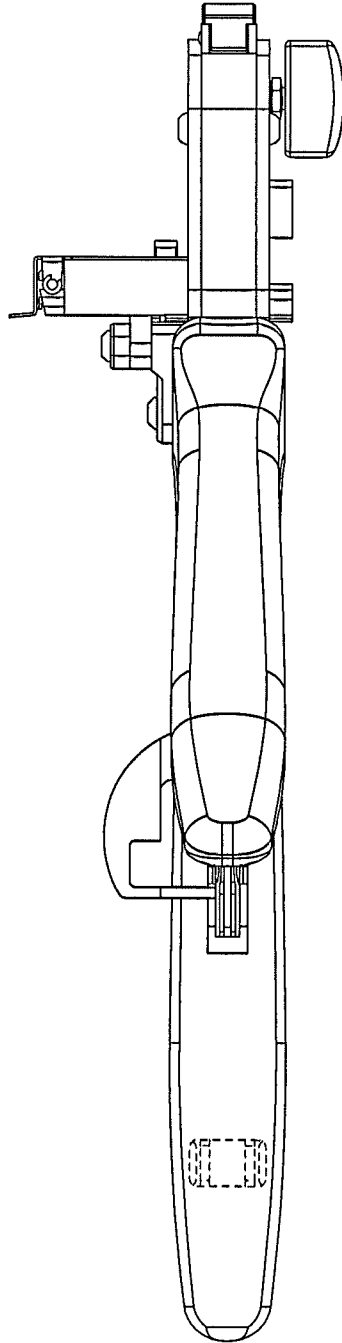

FIG. 5

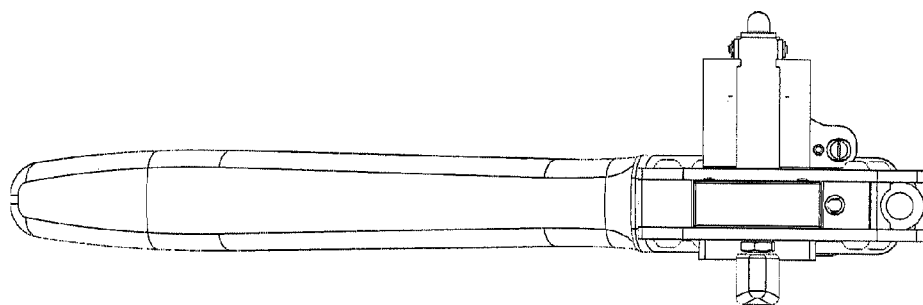

FIG. 6



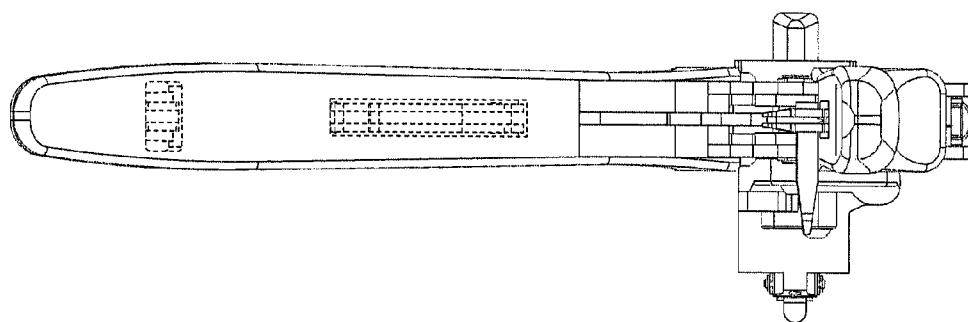

FIG. 7

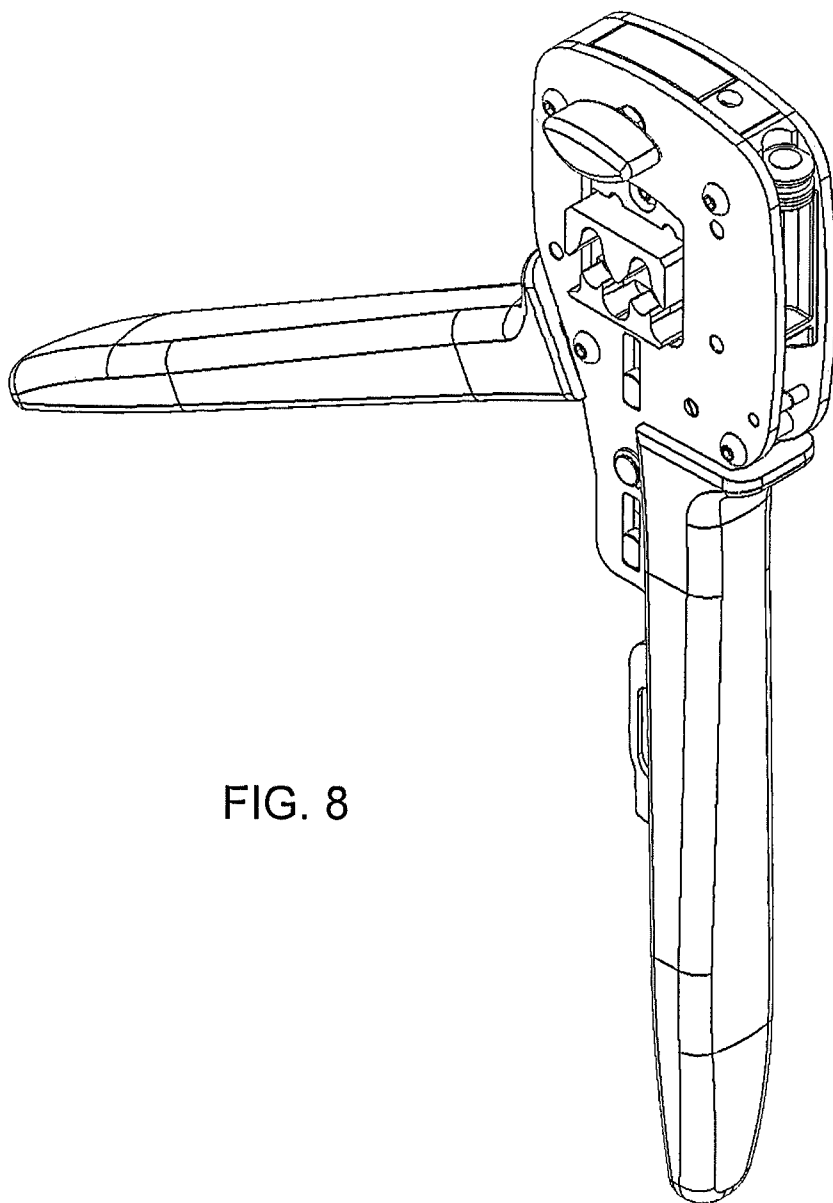

FIG. 8

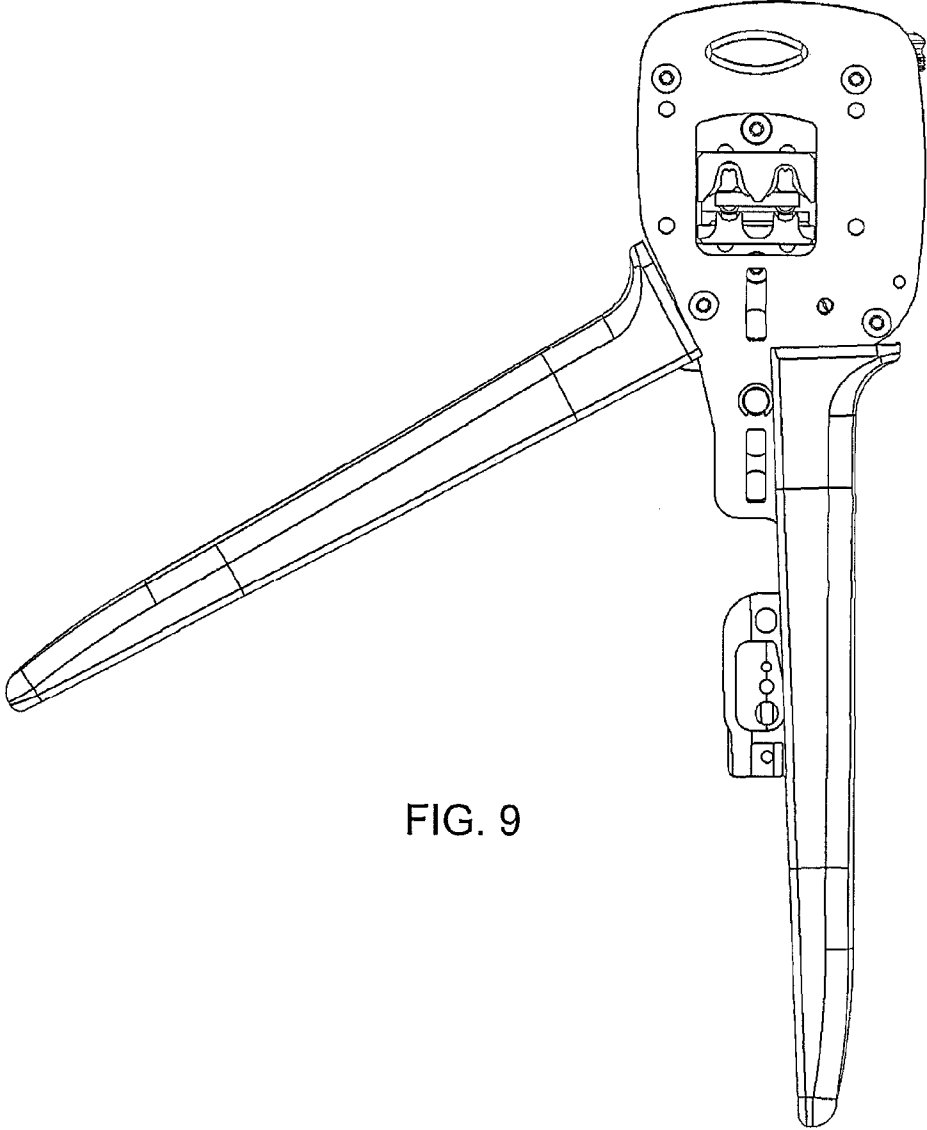

FIG. 9

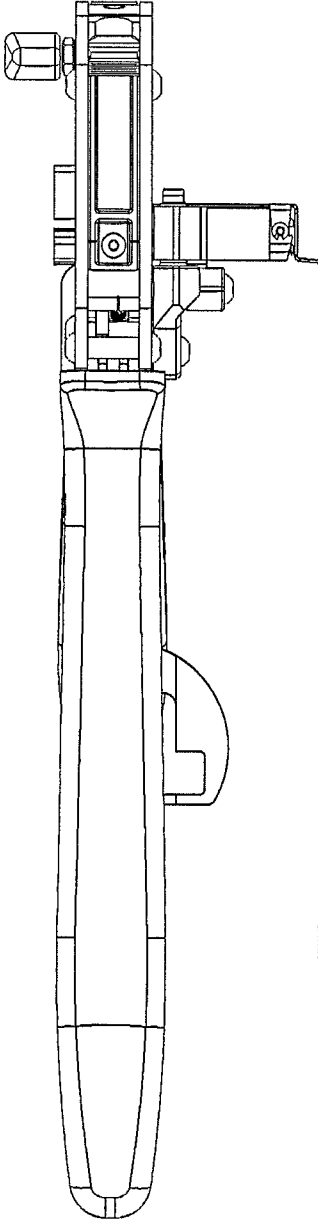

FIG. 10

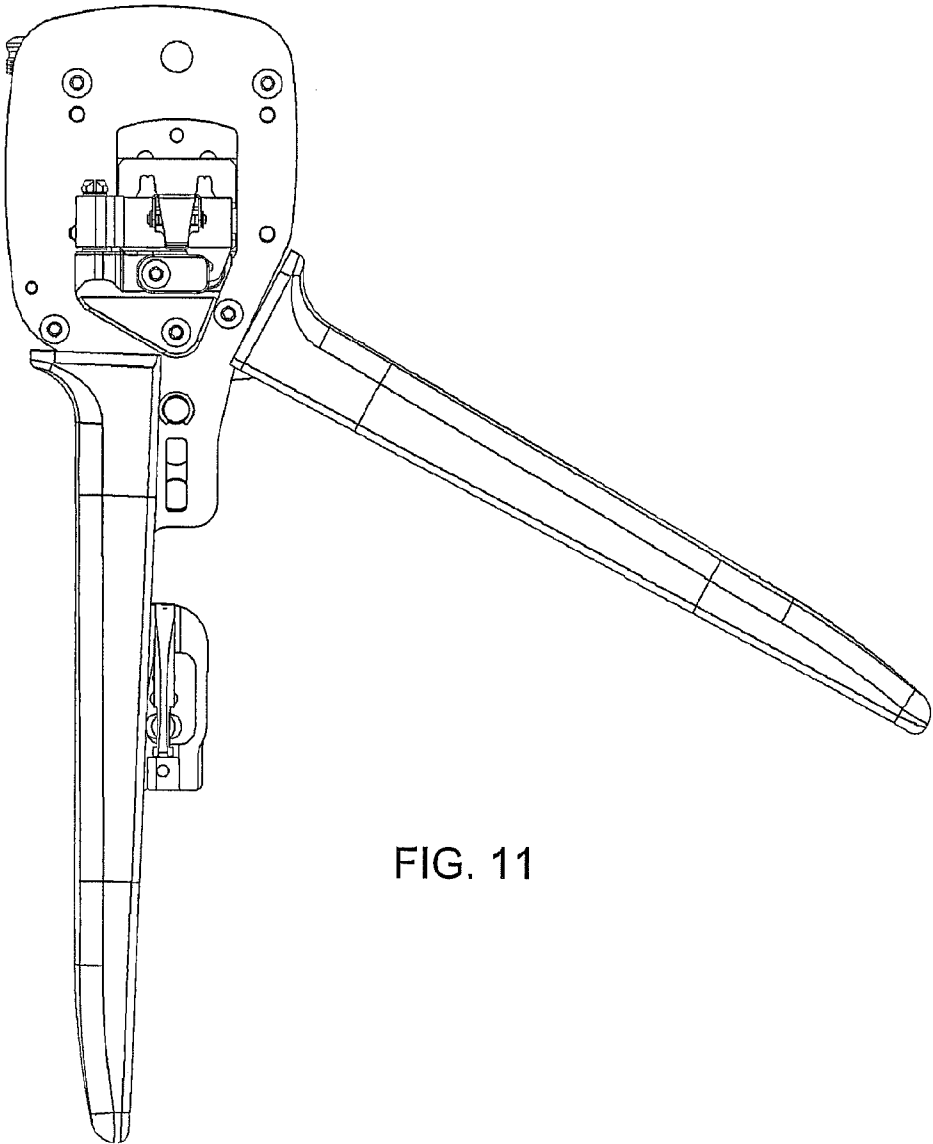

FIG. 11

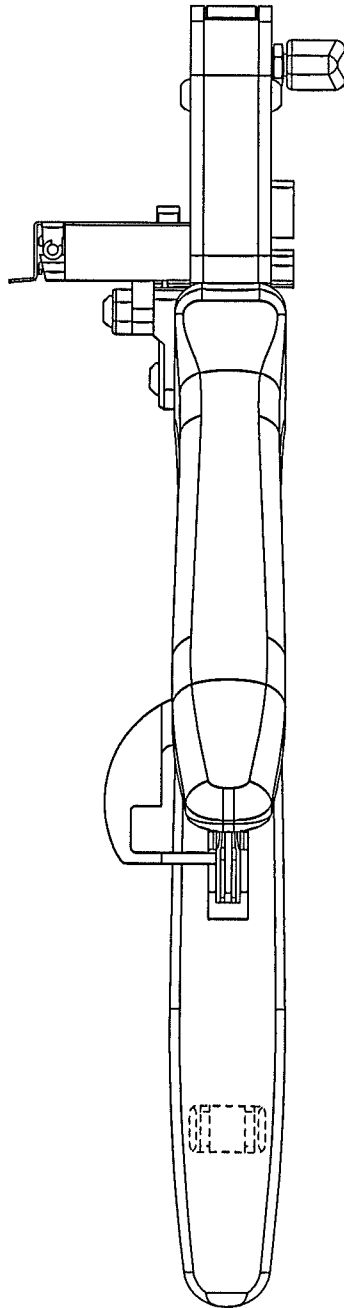

FIG. 12

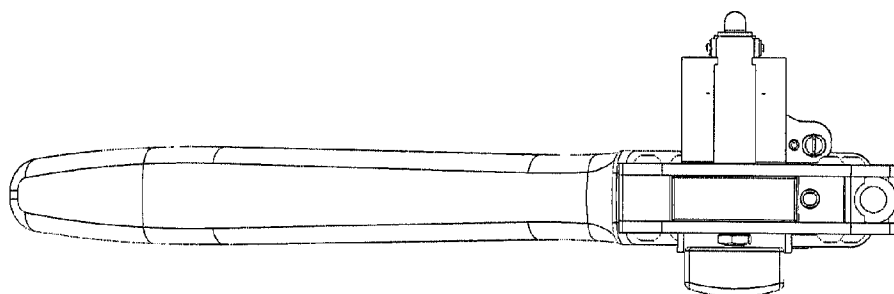

FIG. 13

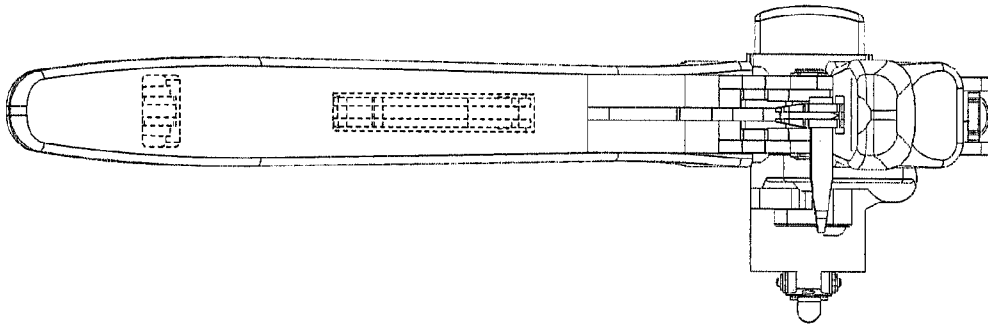

FIG. 14



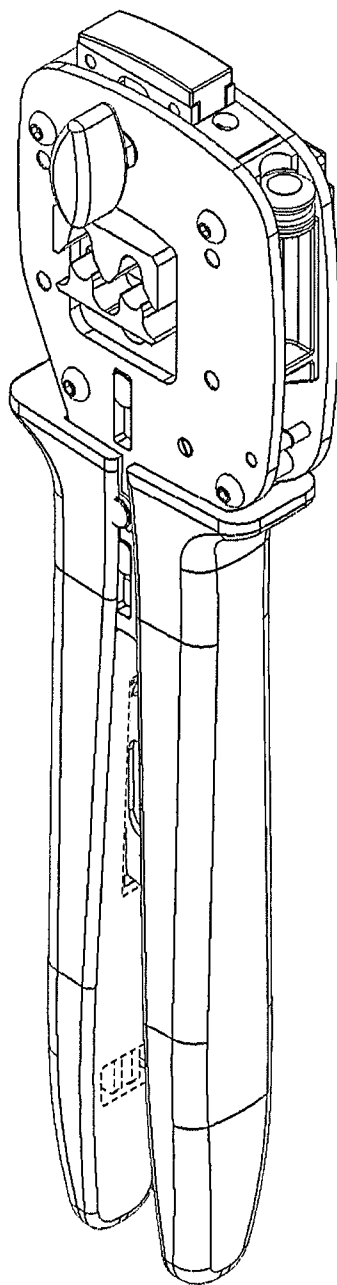

FIG. 15

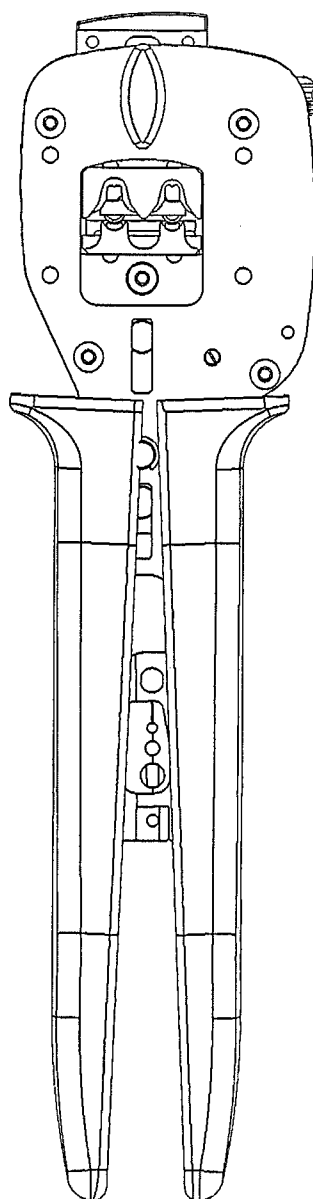

FIG. 16

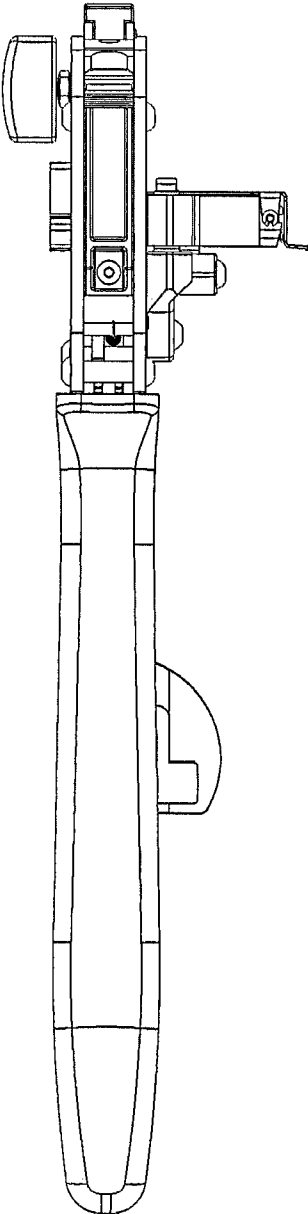

FIG. 17

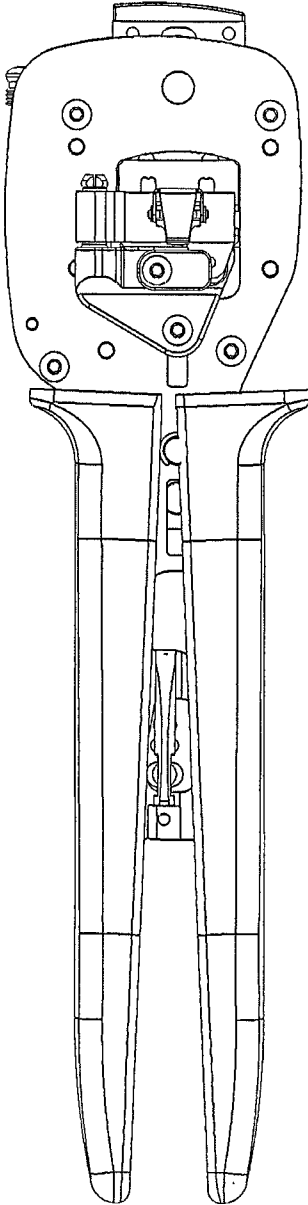

FIG. 18

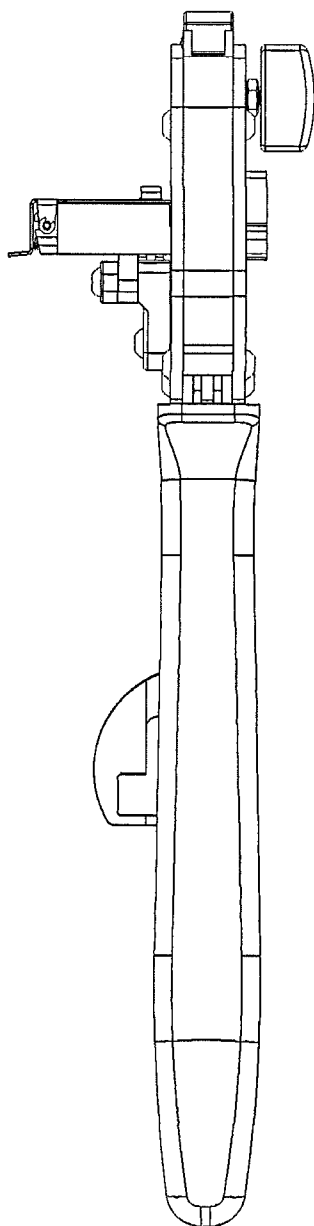

FIG. 19

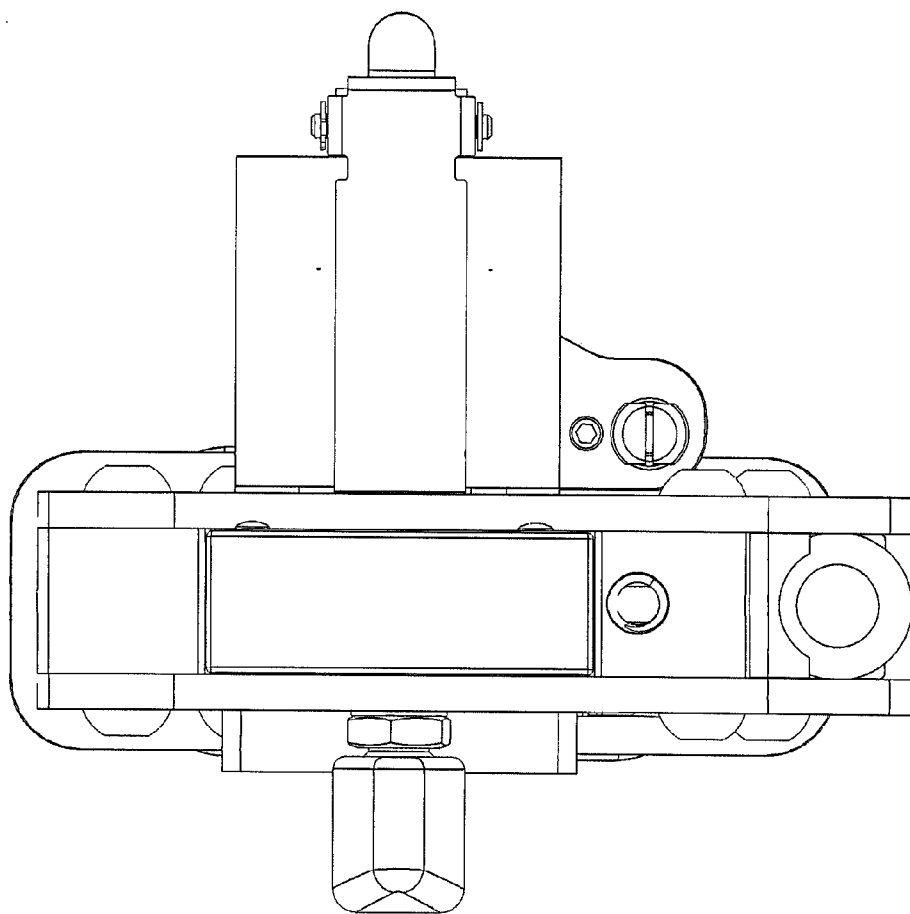

FIG. 20

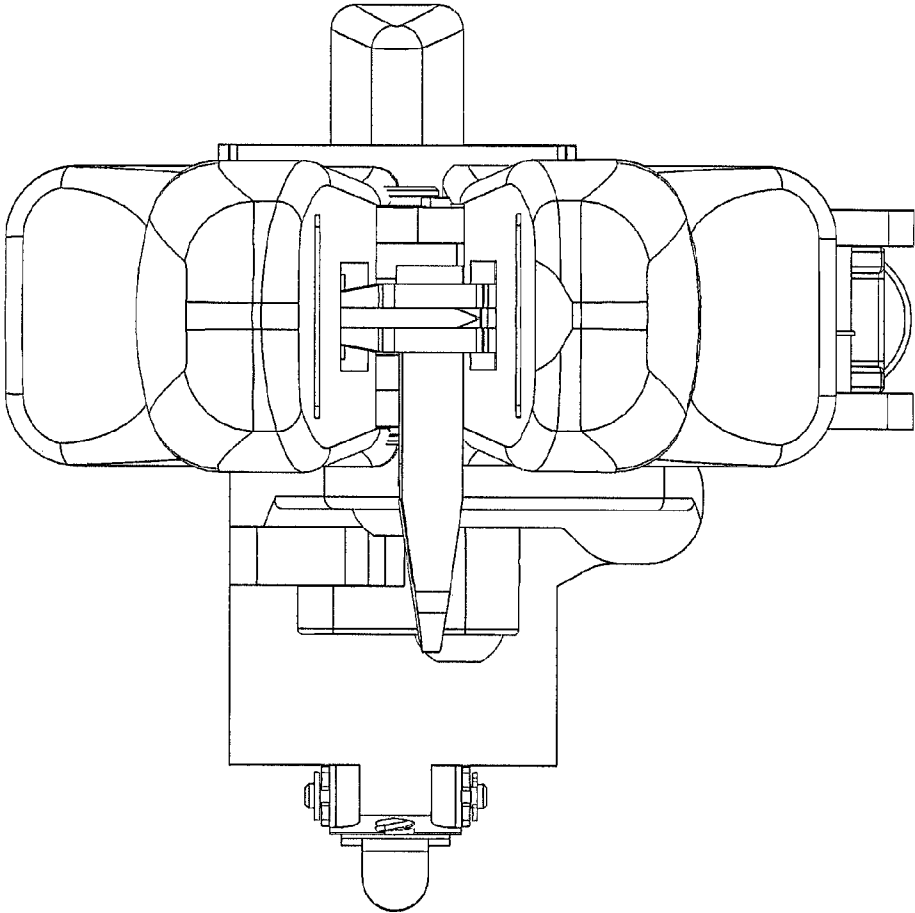

FIG. 21