

April 14, 1970

K. A. G. ATTEBO

3,506,075

DRILL STRING ELEMENT TRANSFER MECHANISM

Filed Oct. 4, 1967

4 Sheets-Sheet 1

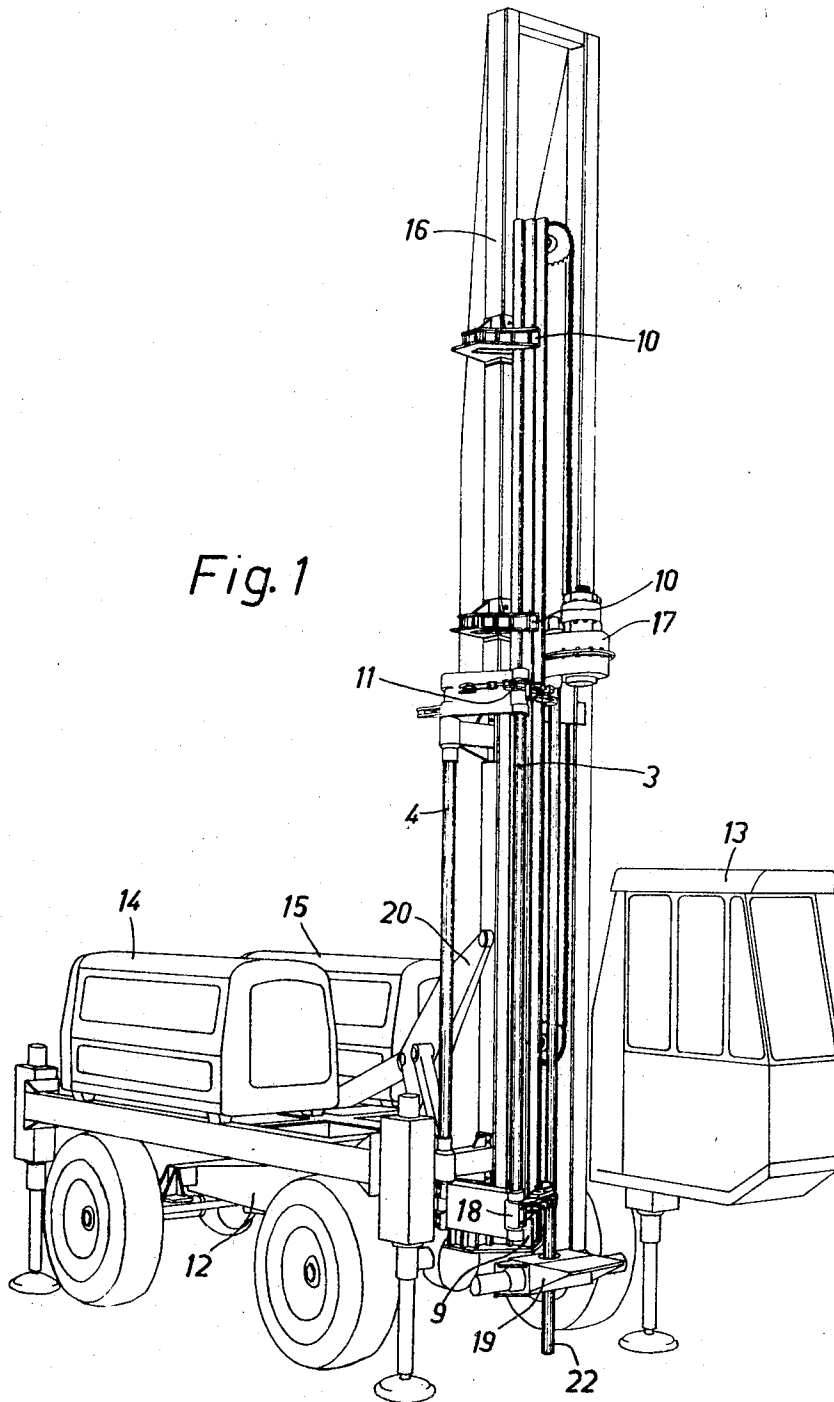

Fig. 1

INVENTOR
KURT ANDERS GUSTAV ATTEBO

By *Greer Marchal Jr.*

April 14, 1970

K. A. G. ATTEBO

3,506,075

DRILL STRING ELEMENT TRANSFER MECHANISM

Filed Oct. 4, 1967

4 Sheets-Sheet 2

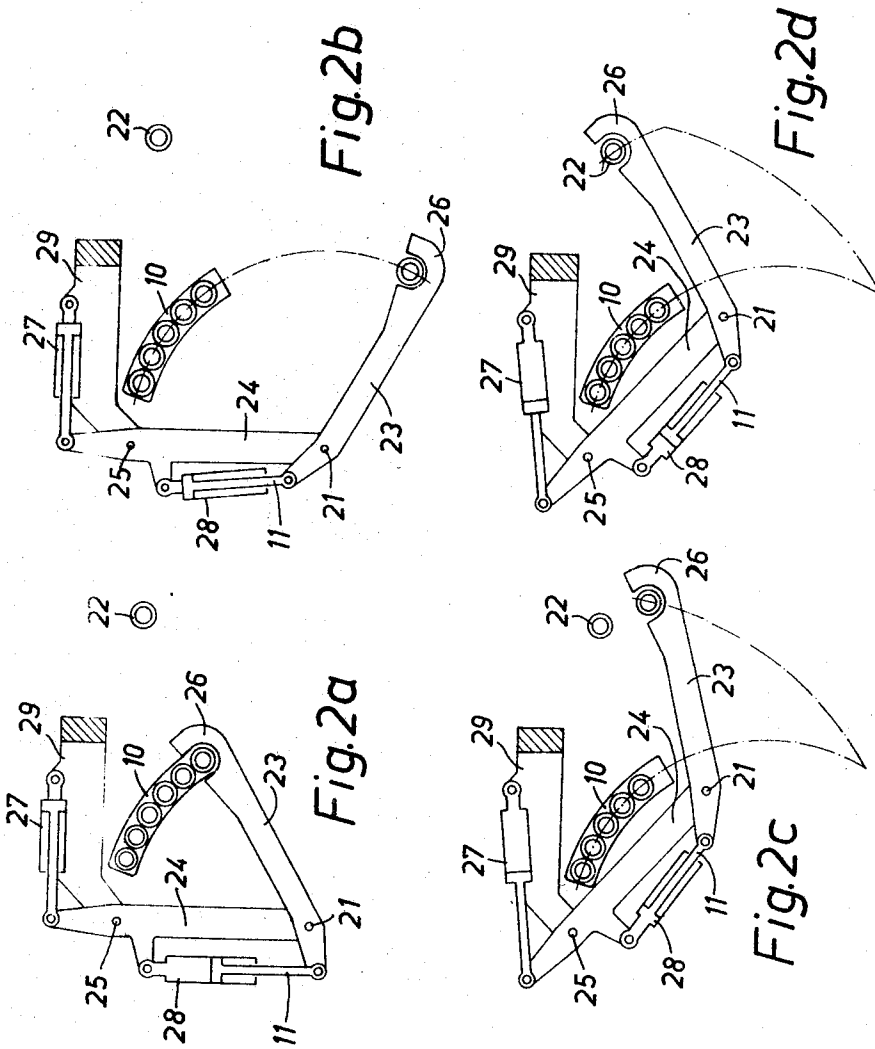

INVENTOR
KURT ANDERS GUSTAV ATTEBO
By *Greer Marichabji*

April 14, 1970

K. A. G. ATTEBO

3,506,075

DRILL STRING ELEMENT TRANSFER MECHANISM

Filed Oct. 4, 1967

4 Sheets-Sheet 3

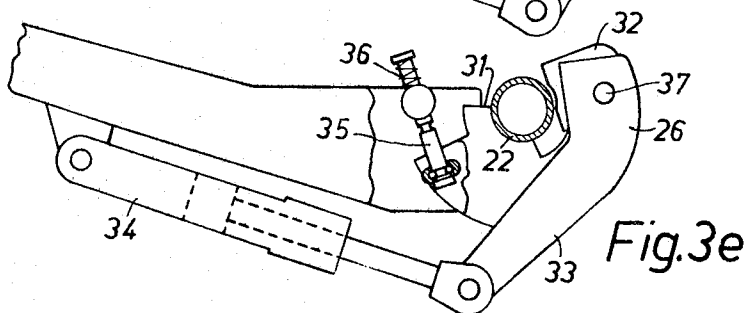
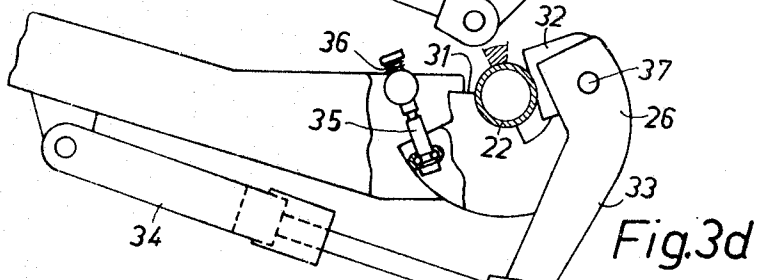
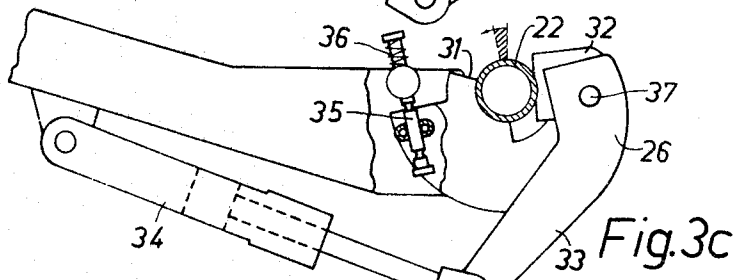
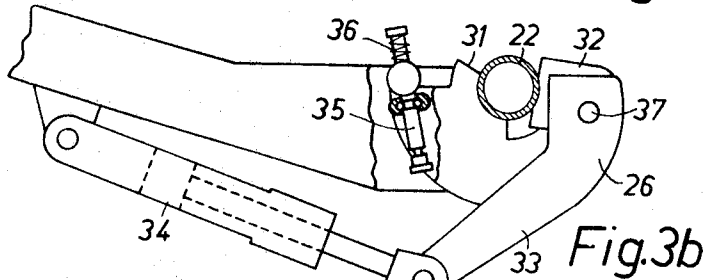
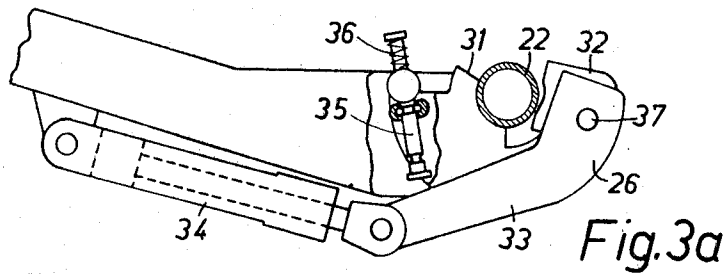

INVENTOR
Kurt Anders Gustav Attebo
By *GREEN MARSHALL JR.*

April 14, 1970

K. A. G. ATTEBO

3,506,075

DRILL STRING ELEMENT TRANSFER MECHANISM

Filed Oct. 4, 1967

4 Sheets-Sheet 4

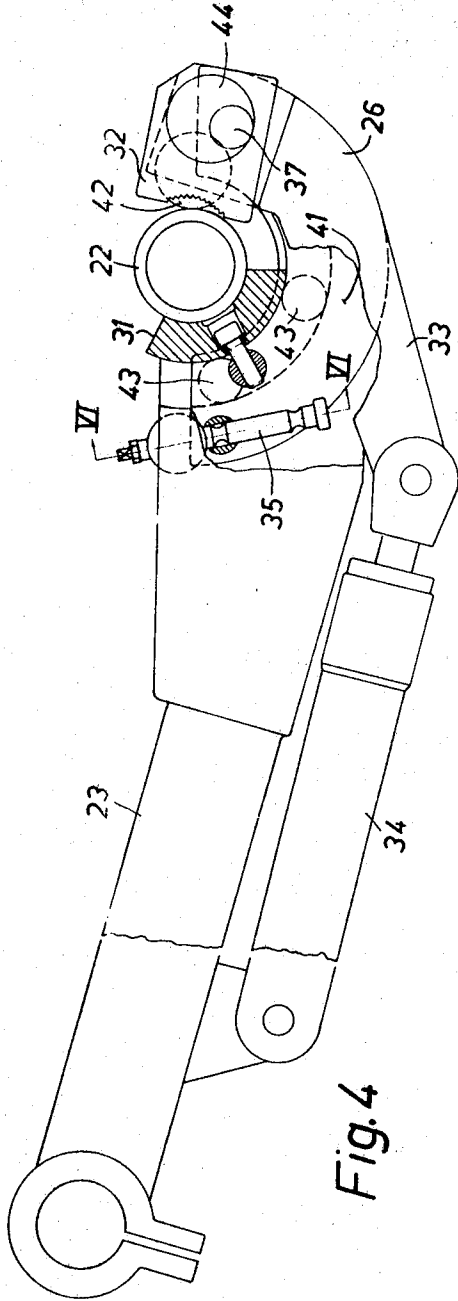

Fig. 4

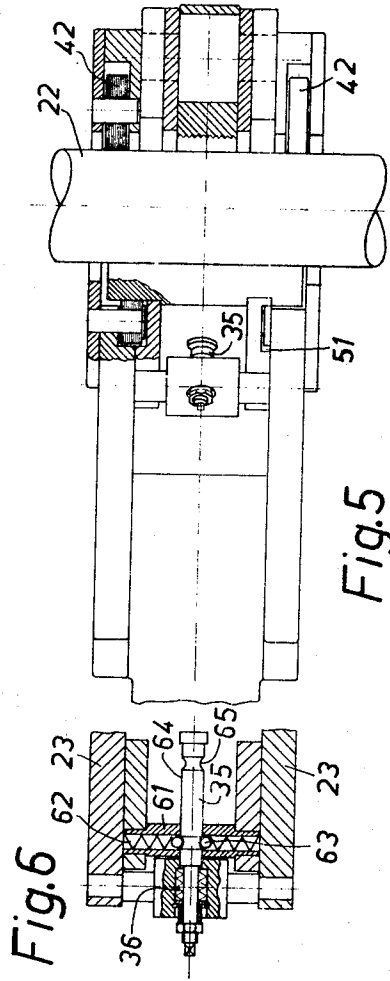

Fig. 5

Fig. 6

INVENTOR
Kurt Anders Gustav Attebo

By *Green, Marichal, Jr.*

1

2

3,506,075

**DRILL STRING ELEMENT TRANSFER
MECHANISM**

Kurt Anders Gustav Attebo, Barkarby, Sweden, assignor
to Atlas Copco Aktiebolag, Nacka, Sweden, a cor- 5
poration of Sweden

Filed Oct. 4, 1967, Ser. No. 672,880

Claims priority, application Sweden, Oct. 7, 1966,

13,594/66

Int. Cl. E21b 19/14

U.S. Cl. 175—52

12 Claims 10

ABSTRACT OF THE DISCLOSURE

For facilitating the handling of the drill string elements, 15
such as tubes or rods, of machines especially for quarry
drilling and rendering such handling possible with small
power of manipulation the invention provides an arrange-
ment comprising at least one gripping arm system, pivota-
ble in a plane perpendicular to the drill string axis, said 20
system comprising two pivotally interconnected arms, viz.
an inner arm and an outer arm, said inner arm being
pivotally mounted at the drilling machine frame on an
axis parallel to the drill string axis, and the outer arm
having, at its free end a gripping means for gripping the 25
drill string element, said inner arm being movably actua-
ted by a first actuator means pivotally connected between
said inner arm and said drilling machine frame, and said
outer arm being pivotally mounted on said inner arm and
pivotally actuated in relation to said inner arm by a 30
second actuator means pivotally connected between said
inner and outer arms for swinging said outer arm relative
to said inner arm.

DISCLOSURE

The present invention relates to drilling machines for 40
sinking wells, for quarry drilling or for other purposes,
and refers to an arrangement for laterally moving the
drill string elements to and fro between a drill string
element magazine and the drill string axis, said drill
string elements being made as tubes or rods.

Drilling machines having arrangements for automatic 45
handling and moving the drill string elements to and from
a working position are known in the art. Thus in one
known type of drilling machine the drill string element
rack is movably mounted on a chassis so that insertion
and withdrawal of drill string elements into and from the 50
rack can be remotely controlled by one man from the
operator's position. Also an arrangement is known for
assembling and disassembling drill string elements, said
arrangement comprising an upper and a lower set of
jaws, the upper jaw set being rotatable by means of a 55
motor.

The present invention has for its object to provide a 60
simple arrangement for handling drill string elements,
such as tubes or rods, more particularly an arrangement
in drilling machines for laterally moving drill string
elements to and fro between a drill string element
magazine and a drill string axis, and when disassembling such 65
elements disengaging the same in a simple way.

A preferred embodiment of the arrangement accord- 70
ing to the invention is characterized by at least one grip-
ping arm system, pivotable in a plane perpendicular the
drill string axis, said system comprising two pivotally in-
terconnected arms, viz. an inner arm and an outer arm,
said inner arm being pivotally mounted at the drilling
machine frame on an axis parallel to the drill string axis,
and the outer arm having at its free end a gripping
means for gripping the drill string element, each of said
arms having a manipulating device for swinging the arms

with respect of each other and with respect to the drill-
ing machine frame.

The advantage of an arrangement according to the
present invention in comparison with such prior art ar-
rangements for handling drill string elements lies in
particular in the fact that the gripping arm system ac-
cording to the invention requires less power for its opera-
tion and makes possible a simplified, quicker and more
rapid handling of the drill string elements when compared
with known arrangements, whereby the dead time in con-
nection with the drilling can be substantially reduced.

The invention will be described in detail in the follow-
ing specification with reference to the accompanying
drawings, in which a preferred embodiment of a gripping
arm system according to the invention for a quarry drill-
ing machine is illustrated by way of example.

In the drawings:

FIG. 1 is a perspective view of the drilling machine with
the gripping arm system according to the invention;

FIGS. 2a-d show diagrammatically in plan views the
gripping arm system of the machine in different positions;

FIGS. 3a-e show more detailed in plan views the grip-
ping means proper at the free end of the outer arm of
the gripping arm system;

FIG. 4 shows still more detailed and on a larger scale
the gripping means in a plan view;

FIG. 5 is a side view of the gripping means of FIG.
4, partially in section;

FIG. 6 is a section through the gripping means, taken
along the line VI—VI in FIG. 4.

In FIG. 1, a drilling machine is shown, having a
wheeled chassis 12, an operator's cab 13, a compressor
unit 14, a hydraulic pump unit 15, a rotary drive unit
17, a mast cradle 20 and a mast 16. A drill string element
rack or magazine is made as a structural unit with the
mast 16. Said magazine comprises channels in support
brackets 10 and a bottom part 9. Although the support
bracket channels can be made straight, arc-shaped chan-
nels are preferred as well as a U-shaped bottom part
having the same curvature as said channels. The mast
16 further includes in its structure a drill string element
support 19 and a main gripping arm system 11 with a
parallel auxiliary gripping arm system 18. At least one
side of the support bracket channels is covered by rubber
or the like so that the drill string elements when inserted
in the magazine are jammed between the channel walls
and thus cannot fall out from the magazine.

In FIGS. 2a-d there is shown diagrammatically the
main gripping arm system 11 according to FIG. 1 in
different gripping positions. The gripping arm system 11
comprises an arm 29, firmly connected with the mast 16,
and two movable arms, viz. an outer arm 23 and an
inner arm 24, with associated manipulating devices 28
and 27, respectively, said manipulating devices in this
embodiment being hydraulically operated cylindrical
jacks. The inner arm 24 is pivoted on the stationary arm
29 through a pivot pin 25, and the outer arm 23 is pivoted
on the inner arm 24 through a pivot pin 21. The hydrauli-
cally operated jack 27 is pivoted at one end on the inner
end of the arm 29 and at its other end on the inner end
of the arm 24. In a similar way the hydraulically operated
jack 28 is pivoted at one end on the arm 24 at a point
somewhat outside of the pivot pin 25 and at its other end
on the inner end of the arm 23. The connection between
the jack 27 and the arm 24 is adjustable so as to permit
an exact adjustment of the axis of the pivot pin 21. The
end positions of the jack 27 are carefully defined by
means of a stop in that end of the cylinder directed to-
wards the mast 16 and by means of an adjusting nut on
the piston of the jack in that end of the piston directed
towards the arm 24. The auxiliary gripping arm system 18

3

according to FIG. 1 has also two pivotable arms, viz. an inner arm and an outer arm, a rod 3 connecting the inner ends of the outer arms of the gripping systems with each other, and a rod 4 connecting the inner ends of the inner arms of the gripping systems with each other. Thus the jacks 27 and 28 are provided to control the auxiliary gripping system in parallel with the main gripping system. The main gripping system 11 is provided to grip the drill string elements substantially at their central point and the auxiliary gripping arm system 18 is provided to grip said elements at their lower ends. Both gripping arm systems have at their outer ends a gripping means, such as 26.

In FIGS. 3a-d is shown the gripping means 26 at the outer end of the outer arm of the gripping system. The gripping means 26 is shown in greater detail in FIGS. 4, 5 and 6. The gripping means 26 comprises a manipulating device 34 (not shown in FIGS. 2a-d) in the form of a hydraulically operated cylindrical jack, a lever 33, jaws 31 and 32, a jaw holder 41 and a ball-type locking device 35 having two locking positions and a return spring 36 therefor. More particularly, the locking device 35, FIG. 6, comprises a bolt 64 having two circular recesses 65 spaced axially thereon, two balls 63 in a hollow stud 61 being adapted to be pressed into one or the other of said recesses by means of springs 62. The stud 61 is fixedly connected to the jaw holder 41. The return spring 36 is nested in a socket member pivotally connected to the outer arm 23, FIG. 6, and bears against an adjustable abutment sleeve on the bolt 64. The jaw 31 is carried at the inner end portion of the jaw holder 41, in which is rotatably journaled at the outer end portion thereof a pivot 37 fixedly connected to the lever 33. The jaw holder 41 is semicircularly arcuate and comprises arcuate guide channels 51, in which supporting rollers 43 carried by the outer arm 23 are received for supporting the jaw holder 41 for partial rotation thereon. The jaw 32 is mounted pivotally on an eccentric journal or element 44 forming part of the pivot 37. As more clear from FIGS. 4 and 5 the gripping means 26 also comprises back-up rollers 42 for the drill string elements received therein.

The arrangement according to the invention operates as follows. At the position of gripping system 11 as shown in FIG. 2a, a drill string element, such as a tube, is taken out from the magazine 10, the gripping taking place substantially at the tube centre of gravity, and the manipulating device, viz. the hydraulic jack 27, being in its inner end position and the jack piston pushed against the stop at the cylinder bottom, the other manipulating device, viz. the jack 28, occupying an intermediate position. According to FIG. 2b the jack 27 is still in its end position, while the outer arm 23 of the gripping system has swung out, the tube as gripped describing an arc with the pivot pin 21 as center. It is to be observed that the magazine is curved with the same radius as the radius of said arc. In the position according to FIG. 2c the jack 28 is still in its end position, while the jack 27 now has occupied its outer end position, the adjusting nut being in contact with the inside of the cover of the cylinder. The inner arm 24 has swung about the pivot pin 25 together with the outer arm 23 and the tube as gripped, said tube describing an arc having the pivot pin 25 as its center. Finally in the position according to FIG. 2d the jack 27 is locked in its outer end position, while the jack 28 has occupied an intermediate position at the same time as the outer arm 23 has swung inwards with the pivot pin 21 as turning point. The tube as gripped is then moved to a position above and coaxial with a tube 22 already in the drill string, and is thus ready to be connected with said latter tube. When moving and assembling tubes, the tube in the drill string is held by means of the tube support 19 in FIG. 1. The new tube as moved from the magazine is screwed onto the driving shaft of the rotary drive until 17 which now occupies its upper position, said tube thereafter being screwed onto

4

the tube in the drill string by means of the rotary drive unit. When disassembling tubes and moving them to the magazine the above operation occurs in the reverse way.

When gripping a tube in the magazine or in the drill string, said tube will in the manner shown in FIG. 3a lie close to the back-up roller 42 and the gripping surface of the jaw 31, as is shown in greater detail in FIG. 4. When the piston of the jack is pressed to the right, the lever 33 turns about the pivot 37. At the same time the jaw 32 is pressed against the tube 22 by the eccentric action from the pivot 37 and the journal 44. This position is shown in FIG. 3b. During the continued pressing of the piston of the jack 34 to the right, the jaws 31 and 32 and the tube as gripped are turned about an axis that coincides with the tube axis due to the supporting of the jaw holder. At the same time the locking device 35 passes from one to the other of its locking positions, because the hollow stud 61 is taken along in the turning of the jaw holder 41. This is more clear from FIGS. 3c and d, the end position of the piston of the jack 34 and the lower locking position of the locking device 35 being shown in FIG. 3d. When the piston of the jack 34 has arrived to its right end position the spring 36 is fully compressed. The jamming effect between the jaws 31 and 32 is now dependent only upon the compression of the spring 36, so the jamming effect can be maximized with respect to the strength of the tube. This is achieved because the piston of the jack 34 abuts against its end stop just at the moment the spring 36 is fully compressed. The mutual turning of the jaws and the tube about the tube axis is utilized for disengaging the uppermost tube from the drill string, said drill string being fixed by means of the tube support 19 according to FIG. 1. FIG. 3e shows finally how the piston in the jack 34 returns to its original position as in FIG. 3a, the spring 36 first being relieved and the tube thereafter being released when the lever 33 returns through the action from the locking device 35 retaining the jaw 31.

I claim:

1. An arrangement in drilling machines, for moving drill string elements to and fro between a drill string element magazine and a drill string axis, characterized by at least one gripping arm system, pivotal in a plane perpendicular to the drill string axis, said system comprising two pivotally interconnected arms, an inner arm and an outer arm, said inner arm being pivotally mounted at the drilling machine frame on an axis parallel to the drill string axis, and the outer arm having, at its free end a gripping means for gripping the drill string element, each of said arms having a manipulating device for swinging the arms with respect to each other and with respect to the drilling machine frame, said gripping means comprising two opposing gripping jaws and a lever with an associated manipulating device supported by said outer arm, one of said jaws having a substantially semicircular gripping segment and defining an opening for insertion of the drill string element and being mounted in one end of a jaw holder, the other end of which is mounted in the outer end of the outer arm and being rotatable around an axis coinciding with the axis of the drill string element as gripped, the other one of said jaws being mounted in the other end of the jaw holder at an eccentric element which is rotatable by means of the lever in such a way that pivoting the lever to and fro causes a movement of the jaws towards and from each other respectively and further characterized in that the jaws are adapted after gripping the drill string element and when further pivoting of the lever, to rotate the drill string element through an angle corresponding to the distance between two locking positions of a locking bolt with a spring, said locking bolt in the tensioned position of said spring corresponding to the end position of the lever manipulating device so that the clamping force between the jaws is dependent only upon the spring tension, said spring, when the lever is pivoting back to its original position, being relieved

5

and thereafter the drill string element being released because the locking bolt retains said one jaw.

2. In an arrangement in drilling machines for moving drill string elements to and from between a drill string element magazine and a position coaxial with the drilling machine, an elongated drilling machine support, a drilling machine movably mounted for reciprocal movement along said support, magazine rack members fixedly mounted on said support for carrying a plurality of drill string elements stacked therein adjacent each other in parallel relation to said support, a pair of interconnected inner arms spaced in the longitudinal direction of said support and pivotally mounted on said support for swinging movement in planes perpendicular thereto, a pair of interconnected outer arms spaced in the longitudinal direction of said support and pivotally connected to the outer end portions of said inner arms for swinging movement in planes perpendicular to said support, gripping means at the outer end portions of said outer arms for gripping said drill string elements, a first pressure fluid actuated power jack connected between said inner and outer arms for swinging the outer arms with respect to said inner arms, and a second pressure fluid actuated power jack connected between said support and said inner arms for swinging the latter relative to said support to and fro between a first position, in which the swing path described by said gripping means during actuation of said first power jack coincides with the axis of at least one of said drill string elements in said rack members, and a second position, in which the swing path described by said gripping means coincides with the axis of the drilling machine.

3. An arrangement according to claim 2 in which said magazine rack members are arcuate defining a radius for the axes of the drill string element supported therein equal to the distance between said gripping means and the pivotal connection between said inner and outer arms.

4. In an arrangement in drilling machines for moving drill string elements to and fro between a drill string element magazine and a position coaxial with the drilling machine, an elongated drilling machine support with the drilling movably mounted for reciprocal movement along said support, magazine rack members fixedly mounted on said support for carrying a plurality of drill string elements stacked therein adjacent each other in parallel relation to said support, a pair of interconnected arms spaced in the longitudinal direction of said support and pivotally mounted on said support for swinging movement in planes perpendicular to said support, gripping means at the outer end portions of said arms for gripping said drill string elements, pressure fluid actuated power jack means operatively connected to said support and said arms for swinging said arms to and fro between a first position, in which said gripping means are coaxial with one of said drill string elements in said rack members, and a second position, in which said gripping means are coaxial with the drilling machine, additional pressure fluid actuated power jack means connected between said arms and said gripping means for causing the latter to clamp a drill string element therein upon initial actuation of said additional power jack means, and means mounting said gripping means for partial rotation on said arms for enabling said additional power jack means during continued actuation thereof to partially rotate said drill string element clamped in said gripping elements through an angle sufficient to uncouple a threaded connection between the uppermost and the next-to-uppermost of said drill elements when in alignment with the drilling axis.

5. An arrangement according to claim 4 in which each gripping means comprises a jaw holder partially rotatably mounted at the outer end of said arms, gripping jaw means on said jaw holder, an eccentric element rotatably journaled in said jaw holder and engaging one of said jaw means for the movement thereof toward and away from said other jaw means, and a lever connected to said

6

additional power jack means and to said eccentric element for movement of said one jaw means towards said other jaw means during initial actuation of said additional power jack means and for partially rotating said jaw holder and jaw means during continued actuation of said additional power jack means.

6. In a drill string element moving means and drilling machine arrangement, a wheeled chassis, an elongated mast means on said chassis, a drilling unit longitudinally movably supported on said mast means for reciprocal movement along a path defining a drilling axis aligned with said drilling unit and parallel with said mast means, a tube support secured forwardly on said mast means in alignment with said drilling axis, drill string elements connectable to and disconnectable from one another and said drilling unit while aligned on said drilling axis, means in said tube support for holding the one of said drill string elements extending therethrough while drill string elements or said drilling unit are connected to or disconnected from said one drill string element, magazine rack members fixedly mounted on said mast means for carrying a plurality of said drill string elements stacked therein adjacent each other in parallel relation to said drilling axis, and at least one gripping arm system for moving said drill string elements laterally to and fro between said magazine rack members and alignment with said drilling axis, each said arm system comprising pivotally interconnected inner arm and outer arm, said inner arm having pivot means thereon mounting each arm system pivotally on said mast means in a plane perpendicular to said drilling axis, a first actuator means pivotally connected between said inner arm and said mast means for swinging said arm system relative to said mast means, a second actuator means pivotally connected between said inner and outer arms for swinging said outer arm relative to said inner arm, a gripping means movably mounted on said outer arm and a third actuator means between said outer arm and said gripping means for actuating said gripping means between gripping and release positions.

7. The drill string moving means and drilling machine arrangement according to claim 6 wherein said actuator means are hydraulic power jacks.

8. The drill string moving means and drilling machine arrangement according to claim 7 in which said magazine rack members are arcuate defining a stacking radius for the drill string element stacked therein equal to the distance between the axis of a drill string element when supported by said gripping means and the axis of pivotal interconnection between said inner and outer arms, and in which there are provided means for limiting swinging of said inner arm between two limiting positions such as to provide in one of said limiting positions swingability of said outer arm along an arc coinciding with the arcuate shape of said magazine racks as defined by said stacking radius, and to provide in the other of said limiting positions swingability of said outer arm along an arc extending through the drilling axis.

9. The drill string moving means and drilling machine arrangement according to claim 7 in which said gripping arm system is pivoted intermediately on said mast means for gripping said drill string element at or adjacent the center of gravity thereof.

10. The drill string moving means and drilling machine arrangement according to claim 9 in which there are provided means for coupling to said gripping arm system a duplicate auxiliary gripping arm system supported pivotally on said mast means for gripping the leading end of said drill string elements.

11. The drill string moving means and drilling machine arrangement according to claim 7 in which said gripping means includes a jaw holder, means mounting said jaw holder rotatably on the outer end of said outer arm about an axis coinciding with the axis of said drill string element when gripped by said gripping means,

7

gripping jaws on said jaw holder, and means mounted on said jaw holder and connected to said third power jack means for firstly moving upon actuation of said jack means said one jaw from said release to said gripping position and then for rotating said jaw holder upon further actuation of said jack means about the axis of rotation of said jaw holder.

12. The drill string moving means and drilling machine arrangement according to claim 11 in which said jaw holder is a segment carrying said jaws thereon in opposed relation to one another, said moving means of said one jaw including an eccentric element on said jaw holder in engagement with said one jaw thereon and a lever connected to said power jack means and said eccentric element and pivotally supported by the latter for

8

moving said one jaw between said release and gripping position upon actuation of said power jack means.

References Cited

UNITED STATES PATENTS

2,737,839	3/1956	Paget	81—53
3,061,011	10/1962	Paget	175—85 X
3,177,944	4/1965	Knights	175—85 X
3,316,783	5/1967	Wilson	81—54

ERNEST R. PURSER, Primary Examiner

U.S. Cl. X.R.

81—53; 173—23; 175—85; 214—2.5

UNITED STATES PATENT OFFICE
CERTIFICATE OF CORRECTION

Patent No. 3,506,075 Dated April 14, 1970

Inventor(s) KURT ANDERS GUSTAV ATTEBO

It is certified that error appears in the above-identified patent and that said Letters Patent are hereby corrected as shown below:

Column 5, line 4, "from" should read --fro--; lines 40-41, "with the drilling" should read --, a drilling machine--.
Column 6, line 9, "aid chassi," should read --said chassis,--.

SIGNED AND
SEALED
AUG 4 - 1970

(SEAL)

Attest:

Edward M. Fletcher, Jr.
Attesting Officer

WILLIAM E. SCHUYLER, JR.
Commissioner of Patents