

Nov. 11, 1947.

J. C. KARNES .

2,430,469

LUMINOUS GUN SIGHT

Filed Dec. 20, 1943

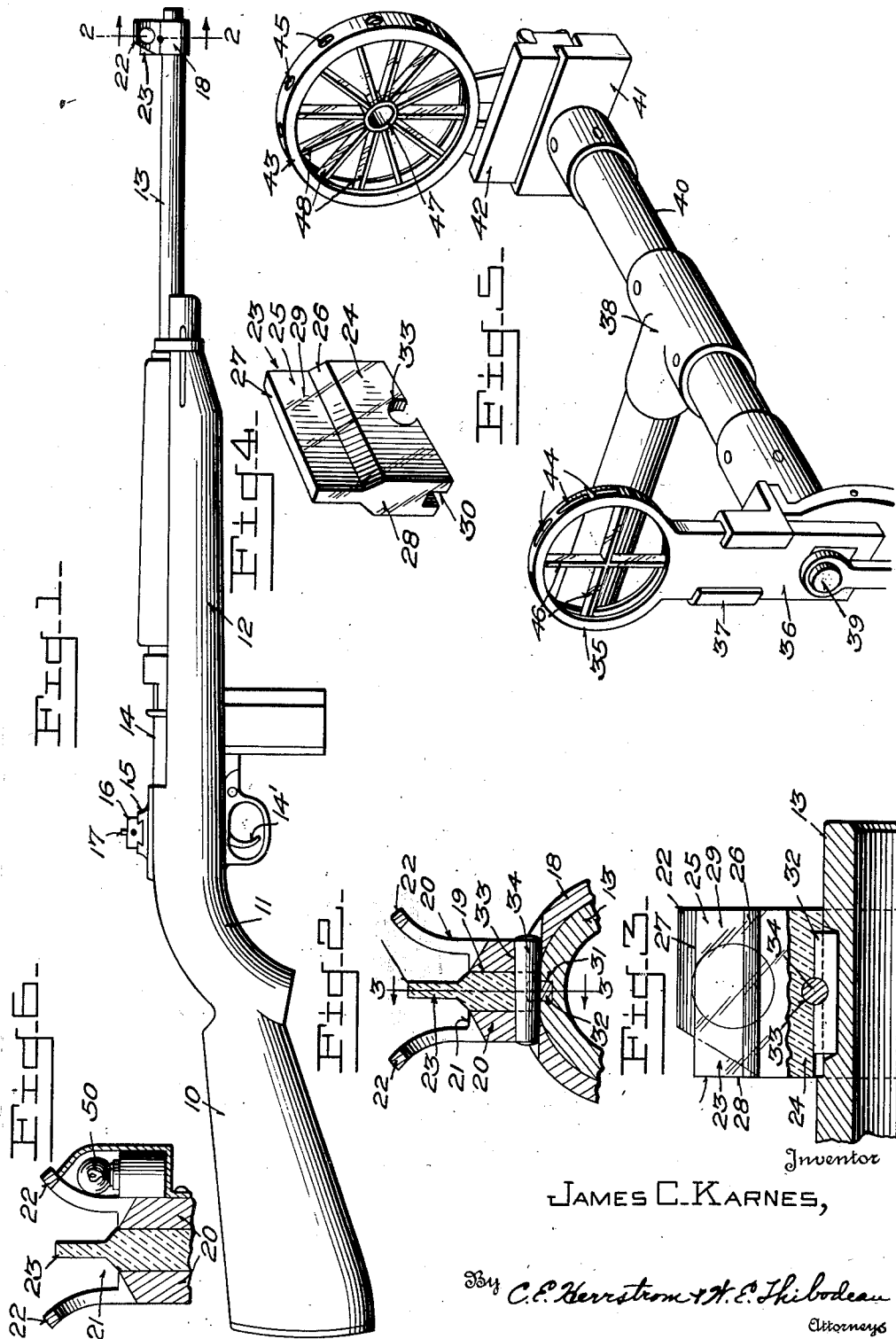

Inventor

JAMES C. KARNES,

*C. E. Kerrstrom & H. E. Thibodeau*  
Attorneys

Patented Nov. 11, 1947

2,430,469

## UNITED STATES PATENT OFFICE

2,430,469

## LUMINOUS GUN SIGHT

James C. Karnes, Buffalo, N. Y.

Application December 20, 1943, Serial No. 514,945

8 Claims. (Cl. 33-52)

(Granted under the act of March 3, 1883, as amended April 30, 1928; 370 O. G. 757)

1

The invention described herein may be manufactured and used by or for the Government for governmental purposes without the payment to me of any royalty thereon.

The invention relates to gun sights and is particularly useful in small arms anti-aircraft weapons, anti-tank weapons, and various automatic arms. It may also be found useful in large caliber guns for limited uses.

It is an object of the invention to provide a sight which will present a luminous line or lines at either the rear sight or the front sight of conventional function by which the alignment of the target with the sights may be more effectively observed by the eye. A special intent of the invention is to present means by which available illumination adjacent the gun may be focussed or concentrated in a line or lines coincident with the vertical plane of the axis of the gun, or on the axis of sights and target, or in a position corresponding to the bead or other sighting element of a gun, whether fixed or adjustable.

It is a further purpose to offer a sight of novel function in utilization in the sight of available illumination at the gun.

A further object is to enable artificial illumination of a sight in a novel way.

It is an advantage of the invention that conventional sight forms may be retained in my invention, usable in customary sighting by men using rifles fired from the shoulder, or automatic or other weapons mounted on stationary mounts, portable or fixed on tank or truck chassis or on aircraft structure.

A further advantage is to present a sight structure embodying my invention, which will be light in weight, free from likelihood of adhering ice, which will not corrode or deteriorate rapidly in the uses to be expected in military operations, and will not deteriorate objectionably by wear, strain or breakage in ordinary use over a reasonable life, and which may be easily replaced or maintained in effective condition.

Additional objects, advantages and features of invention reside in the arrangement, construction, and combination of parts involved in the embodiment of the invention, as will be apparent from the following description and accompanying drawings, wherein:

Figure 1 is a conventional side elevation of an army infantry rifle on which my invention is incorporated;

Figure 2 is a fragmentary cross section at the front sight and barrel;

Figure 3 is a fragmentary side elevation of the front sight, partly in section;

2

Figure 4 is a perspective view of the front sight insert.

Figure 5 is a perspective view of my invention adapted to the conventional form and mounting of the sights of an anti-aircraft gun of moderate caliber.

Figure 6 is a view, partly diagrammatic, showing the use of artificial illumination.

There is illustrated a conventional representation of a small arm adapted to be fired from the shoulder of the infantryman or other person, and having a stock 10, with grip 11, and forward barrel stock 12, in which the barrel 13 is set. A breech closure 14 of usual construction is also shown. The gun may include any suitable firing mechanism, not shown, and trigger 14'. Rearwardly of the breech closure there is an elevated rear sight base 15 on which there is transversely adjustable a sight piece 16 on which a pin or bead 17 is erected. Any usual means for effecting the transverse adjustment may be employed, and, if desired, elevating and lowering means for the bead may be employed; also any other conventional rear sight may be employed in this in-

stance. Adjacent the muzzle of the gun a clamp collar or split guard ring and mount 18 for the front sight is provided, which is fitted with a moderate drive fit on the barrel.

This ring is formed with a gap 19 or slot at its upper side, beside which upstanding guard plates 20 are formed on the ends of the ring parallel to the vertical diametrical plane of the barrel. The upper parts of these plates are relieved on their inner sides, as at 21 and are curved outwardly and divergently a distance forming guards proper 22.

Fitted removably between these plates there is a front sight 23, consisting of a block of a material which will be more particularly described hereinafter, the base 24 of which is of a thickness to fit tightly between the plates and against the barrel, but the upper part 25 of which in this instance is of much less thickness, shoulder fillets 26 being formed at the junction of the two. The top edge 27 of the upper part is parallel to the barrel, though this is not essential. The ends of the block may be smoothly finished in planes at right angles to the axis of the barrel, although the rear end 28 may incline rearwardly slightly at its upper part to avoid possibility of reflection thereby of light rays from the rear and to the right or left or above the user when aiming the arm. The upper part 25 of the sight has parallel lateral faces 29 of a vertical and longitudinal extent much greater than the transverse

measurement of this part, and may be of a thickness corresponding to that of the conventional sight bead or pin, or may be slightly thicker or thinner, according to the preference of the user and sighting practice. In the present instance it may be slightly thicker than the pin of the front sight. Its upper edge may be shaped to correspond to a knife edge or otherwise.

In the bottom face of the sight and in the top of the barrel, aligned longitudinal slots 30 and 31 are formed receiving a key 32 by which the sight is fixed against lateral displacement on the barrel, and a transverse tapered bore 33, is formed through the bases of the plates 20, the lower edge of the block 23, and adjacent parts of the ring proper, as well as through the upper edge of the key 32 and a peripheral part of the barrel, in which bore a tapered pin 34 is engaged to hold the parts against longitudinal movement on the barrel 13. The opening through the base of the sight is therefore in the form of a major segment of a circle. The sides of this opening being as a result convergent downwardly, the pin consequently will serve to prevent the block from being pulled radially from between the plates 20.

The material of the front sight is so formed as to be either translucent or transparent, and in practice has been a transparent body capable of transmitting therethrough a proportion of light rays incident to its lateral faces. These faces are preferably polished, although not essentially. A transparent plastic has been employed in which a material or materials are incorporated capable of responding to light rays incident to its surfaces 29 by diverting generating or otherwise emitting rays radially within the material, so that a substantial portion will be projected in directions coincident with or closely following the major plane of the upper part 25, or at such angles thereto as to be retained in the piece by reflection (especially total reflection) therewithin by the faces 29, until such rays reach or pass from the edges of the part 25. As a result, when the piece is exposed to ambient or even solely lateral light, a considerable concentration of light is produced at its narrow edges. These edges, then appear as a bright light or line, much more brilliant than a simple white surface illuminated by the available ambient daylight or sunlight if sunlight falls on the block 23. It is an advantage of the sight that it utilizes light from many directions simultaneously to produce the necessary concentration at the sight line, and is in that respect superior to a simple mirror or prismatic reflector reflecting light from a limited particular direction.

After one method, a fluorescent material such as a dye, is incorporated in the material of the sight, responsive to incident light waves to generate and radiate light waves, a large part of which, directly or by reflection inwardly from the surfaces 29, will move a substantial distance through the material toward the edge boundaries of the sight each point of origin adding by increment to light moving toward the edges up to a distance at which transmission is limited by absorption, so that at the edges a more or less bright illumination is manifest appearing as a bright line readily distinguishable even when the incident external illumination is comparatively slight.

After another method there may be incorporated in the mass of the material of the sight a structural property which by scattering or by refraction or otherwise will divert incident light with similar effect. In the case of the scattering effect the multiplicity of points of origin within

the material of rays at an angle to the polished faces 29 will each add on increment tending to be confined to paths within the body leading to the edges of the sight by reflection and by direct movement within the material so that the cumulative effect at the edges is manifest.

For these purposes a transparent medium has been used for the body of the material. The edges may have a slight grained or granular form in order to act as a transmitting screen on which the concentrated light may become visible. A material having the desired properties is commercially available, produced by the E. I. du Pont de Nemours & Company, of Arlington, New Jersey.

In the use of the arm with the sight in the form described the upper part 25 may be extended slightly above the mean line of sight in ordinary ranges of the gun and the elevation determined by the distance the opaque rear sight extends upwardly before the bright rear edge of the front sight. If the latter is thin enough, it will appear as a thin line of light stopping at its upper end on the line of sight, this corresponding to the present practice with the army rifle, although various other practices may be followed.

Calibrating and elevating means of any desired kind may be associated with the sights. Arrangements for the purposes being well understood.

An adaptation of the invention where both the rear and front sights are of the pseudo luminous or luminous character and also in forms corresponding to the conventional shapes, is shown in Figure 5. Here the rear sight comprises a metal ring 35, having a flat shank 36 in a plane with the ring and slidably adjustable vertically in a bracket 37, on a sight mount 38 all of familiar construction. A binding screw 39 on the shank locks it to the mounting at adjusted positions. The mount consists principally of a rectilinear bar 40 at the rear end of which the bracket 37 is secured, and at the forward end of the bar a transverse front sight base 41 is fixed on which a foot piece 42 of the front sight ring 43 is transversely slidable, being secured in adjusted positions by familiar means not shown, the structure of this sight as described thus far being well known.

The ring 35, as customary is smaller than the ring 43, and has formed therein a series of light-admitting openings 44 elongated in the direction of concentric circular elements of the ring, and the front sight ring is formed with a similar series of openings 45.

Fixed in the ring 35 there are two cross bars 46 at right angles to each other, one being normally vertical and the other horizontal. These bars are of thin flat material such as before described having a substantial major transverse dimension, sufficient to permit incidence of light readily on their two major or lateral faces. The openings 44 and 45 contribute to the access of light to the bars.

In the front sight ring there is a concentric center ring 47 very small as compared to the rings 35 and 43, and to this there are attached a multiplicity of radial bars 48, extending to and secured to the ring 43. The bars 48 are of such number as to leave ample spacing between their bases at the center ring for sighting a target through the sight, and in the present instance twelve are shown, which includes vertical ones at top and bottom of the series and also horizontal ones at each side. These bars, are similar to the bars 46 in material and transverse dimensions.

2,430,469

5

The bars 46, ring 47, and bars 48 will all function in response to light incident on their major faces to produce a substantially uniform concentration of light at the edges, and the front and rear sights thus constructed may be used by the gun pointer in the familiar ways heretofore practiced or which may be newly devised due to the advantages of my invention.

The sights embodying my invention as disclosed have the advantage of being clearly distinguishable under dim lighting conditions, where it would be difficult to distinguish the ordinary sights heretofore used. At the same time the illuminated edges of the sight elements do not become glaring or so brilliant as to impair ocular perception of the target in strong light.

In one form of the invention I have provided a small battery-energized lamp 50 beside the sight 23, hooded so that its light falls only on the sight piece 23, and this may be made attachable, as a lamp and cell unit, to the guard piece 20 at one side, or a sight unit incorporating the lamp and cell may be used interchangeably with the piece 23, or including a barrel mounting.

A material, among others, for producing a scattering effect would be a suspension in the plastic during manufacture, of fine particles of a sulphur salt which in fine form are capable under incident light of throwing laterally scattering rays of light in the blue portion of the spectrum and in larger size such lateral rays will tend toward the red end of the spectrum. Fluorescent agents adapted to be incorporated in plastics available for the use described include anthracene, which has been used in cellulose acetate, rhodamene, uranium, fluorescein and numerous fluorescent dyes.

Using either fluorescent material or one with a scattering effect, certain radiated light will be thrown out through the lateral broad faces 29 of the block but this is immaterial and does not make the sight conspicuous. In the case of fluorescent material there is a slight glow perceptible, and in the case of scattering effect a grey is created corresponding to a piece of grey paper. Light transmitted through the part 25 in either case is colored according to the nature of the material used.

The divergent upper surfaces of the guards 22 may serve additionally as reflectors, throwing light from above against the sides of the block and increasing its radioactive function.

The invention is not considered as including in its scope the use of radioactive luminous paint and the like as a surface application to define and itself constitute the actual bright line or figure which it is desired to produce.

I claim:

1. A sight comprising a guard and mount, said mount having a lower part shaped to fit slidably on a barrel and the like and having a channel-like space therein over the barrel, a photoactive light emitting sight body of the character described set in said space, said mount having upwardly extended laterally divergent guard parts co-extensive in height and length with the sight body, and means to secure the mount and body in operative positions on a barrel, including a barrel part in the mount, said sight body being set on and against the barrel, longitudinal key slots being formed in the under face of the sight body and in the top of the barrel part, and a key set in said slots.

2. In a gun sight, a sight line defining member

6

of a light transmitting material having a thickness corresponding to that of a conventional sight pin or less, said member being of much greater dimensions longitudinally of the sight and vertically than said thickness, said member having lateral reflecting surfaces thereon and a line-defining edge, said member being constructed with photoactive light emitting material, whereby radiation and reflection of light from said surfaces within said material will produce a concentration of light at said edge and means to mount said member in the sight with its major dimension aligned with the line of sight and having said edge exposed.

3. A sight piece comprising a thin transparent body having parallel lateral reflecting surfaces and constructed and adapted to generate and radiate light within said body, so that by radiation and reflection within the body a concentration of light will be formed at distal edge parts, a sight device constructed to establish a line of sight including said sight piece, said sight piece being mounted with an edge coincident with said line of sight.

4. A sight comprising a guard and mount having a lower part constructed for mounting on a gun barrel its upper part consisting of upstanding ears spaced to form therebetween a channel-like space over the barrel, a thin elongated sight body of transparent material having lateral reflecting surfaces, set in said space and having at least one upstanding edge exposed so as to be aligned with the line of sight, said ears being bent laterally outward to form divergent guard parts substantially coextensive in height and length with the sight body, said body having therein a photoactive light emitting material, and means to secure the mount and body in sighting positions on a barrel.

5. The structure of claim 2 in which said member comprises a transparent plastic containing a fluorescent material.

6. The structure of claim 3 in which said body comprises a transparent solidified plastic containing a fluorescent material.

7. The structure of claim 3 in which said member consists of a transparent medium containing a photoactive light emitting material.

8. A sight comprising a guard and mount body having a lower part shaped to fit slidably on a barrel and the like and having a longitudinal channel-like space therein over the barrel, a sight body set in the channel-like space, a transverse bore being formed through the mount and sight body and part of the barrel, the sides of said bore in the sight body including an angle of more than 180° and including also a small fraction of the thickness of the barrel, and a transverse pin fitted in the transverse bore.

JAMES C. KARNES.

#### REFERENCES CITED

The following references are of record in the file of this patent:

#### UNITED STATES PATENTS

Number	Name	Date
604,344	Cooper	July 12, 1898
70 1,043,678	De Bertouch	Nov. 5, 1912
2,181,081	Ganaway	Nov. 21, 1939

#### FOREIGN PATENTS

Number	Country	Date
75 141,296	Great Britain	Apr. 6, 1920