



(19) **United States**
(12) **Patent Application Publication**
Orcutt

(10) **Pub. No.: US 2008/0245087 A1**
(43) **Pub. Date: Oct. 9, 2008**

(54) **SYSTEM FOR CONTROLLED FLUID HEATING USING AIR CONDITIONING WASTE HEAT**

(76) Inventor: **John Walter Orcutt**, Richardson, TX (US)

Correspondence Address:
JOHN W. ORCUTT
1800 N. CHEYENNE DR.
RICHARDSON, TX 75080-2904 (US)

(21) Appl. No.: **11/784,478**

(22) Filed: **Apr. 7, 2007**

Publication Classification

(51) **Int. Cl.**
F25B 27/02 (2006.01)

(52) **U.S. Cl.** **62/238.7**

(57) **ABSTRACT**

A system is disclosed which utilizes air conditioning waste to heat a second fluid such as swimming pool water. The second

condenser for pool water heating is connected in parallel with the air conditioning condenser. An accumulator is connected between the condensers and the expansion valve to absorb fluctuations in refrigerant level due to different operating conditions caused by the pool water heating, thereby ensuring that liquid refrigerant is always supplied to the expansion valve. A controller reads the ambient air temperature at the air conditioning condenser and reads the air conditioning system condensing pressure and uses an algorithm to compute ambient air fan speed at the air conditioning condenser based on these two inputs to maintain a consistent heated pool water temperature.

An alternate system includes first and second condensers connected in series with an accumulator connected between the second condenser and the expansion valve and a pressure equalization line connected between the compressor and the accumulator. A controller reads the ambient air temperature at the air conditioning condenser and reads the air conditioning system condensing pressure and uses an algorithm to compute ambient air fan speed at the air conditioning condenser based on these two inputs to maintain a consistent heated pool water temperature.

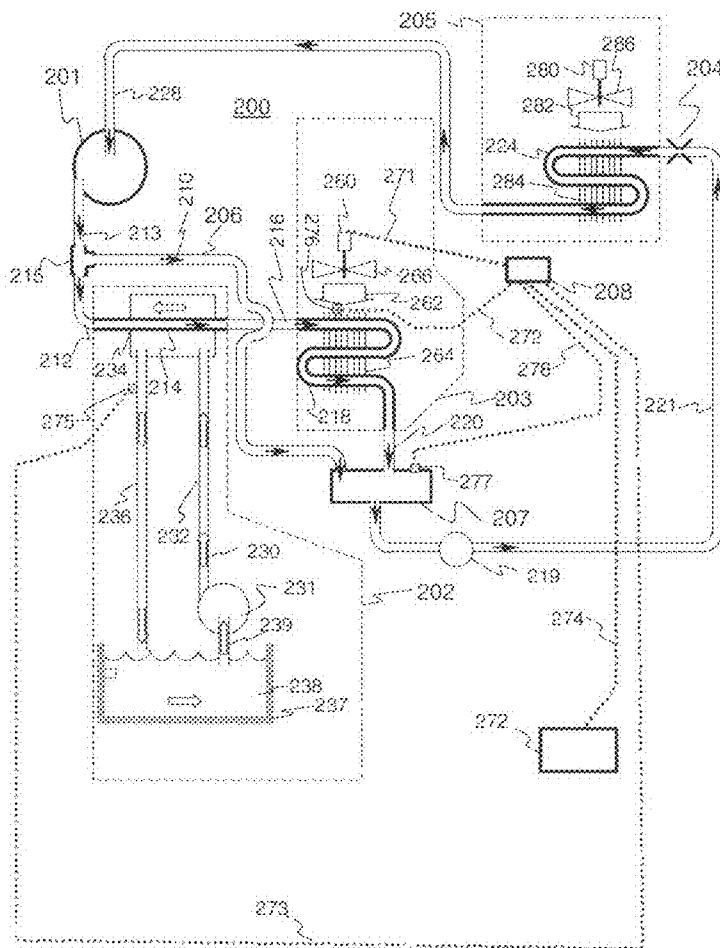
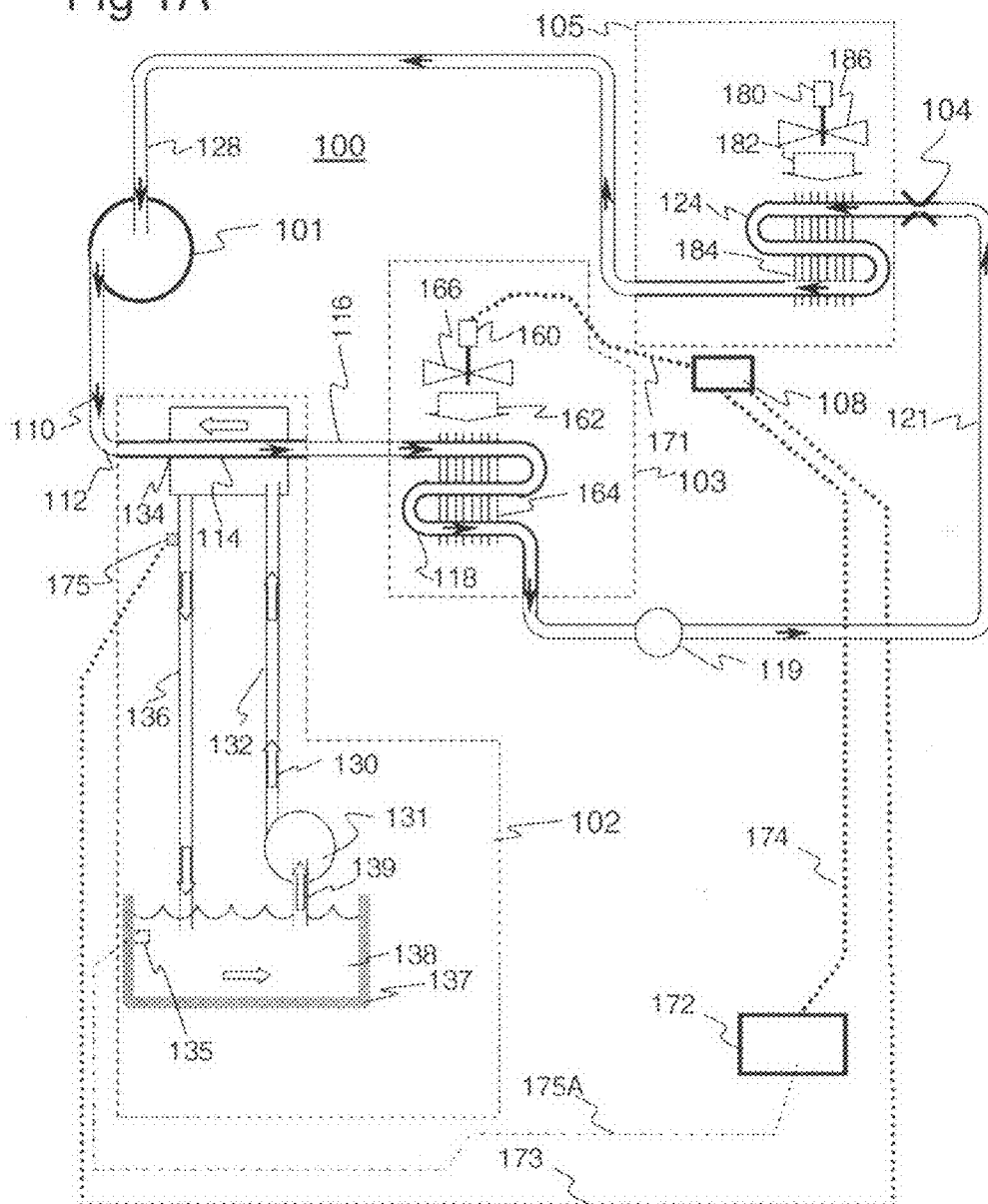

Fig 1A



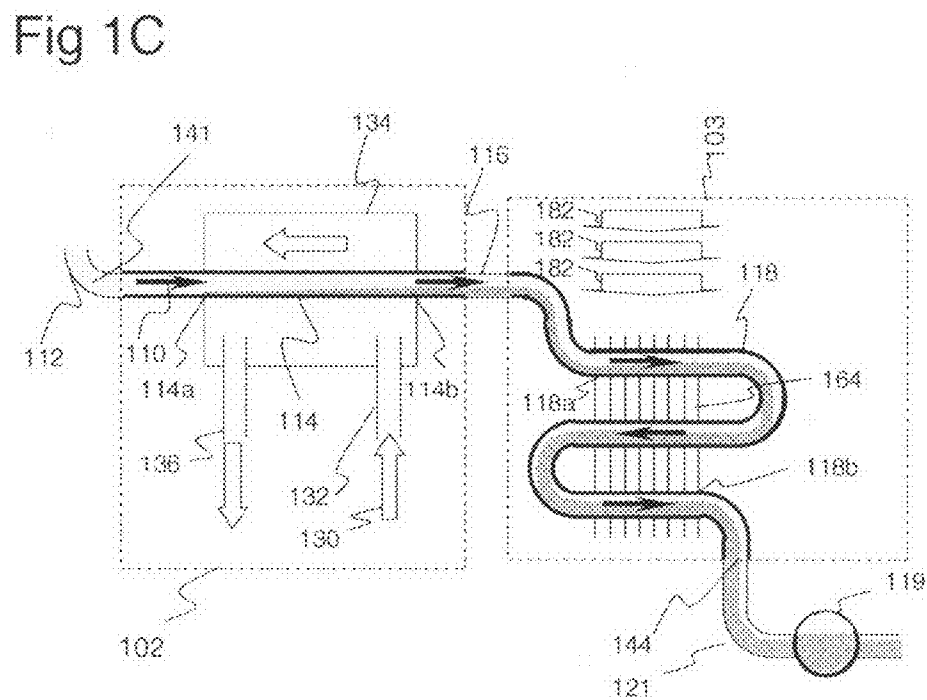
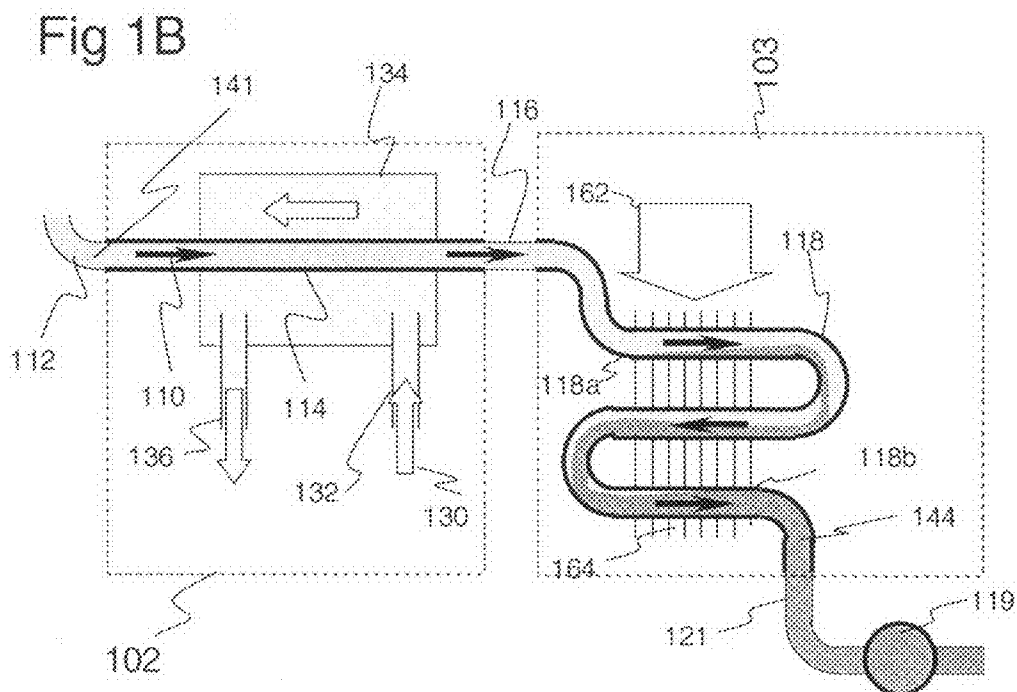

Fig 1D

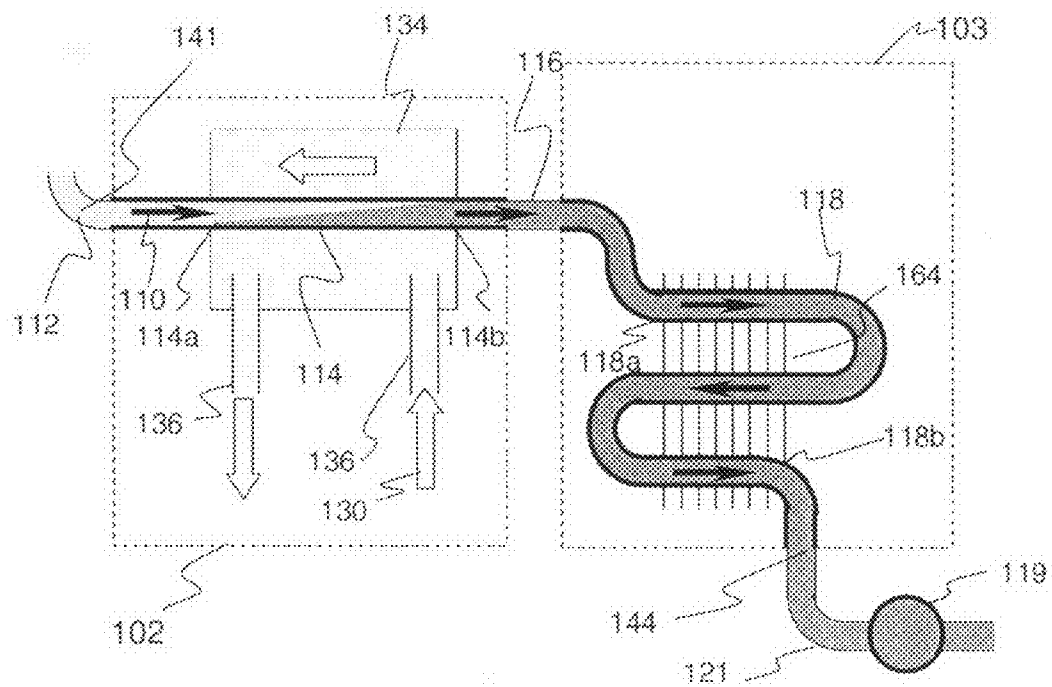

Fig 1E

Theoretical Outlet Water Temperature, Air Conditioning System Condensing Pressure, Condenser Fan ON/OFF, and Hot Water BTU/Hr Requirements at various Operational Conditions for Fig 1A with 90°F ambient at the refrigerant to air condenser, 60°F water inlet to refrigerant to water condenser, where the refrigerant to water condenser has the same capacity as the air conditioning system.

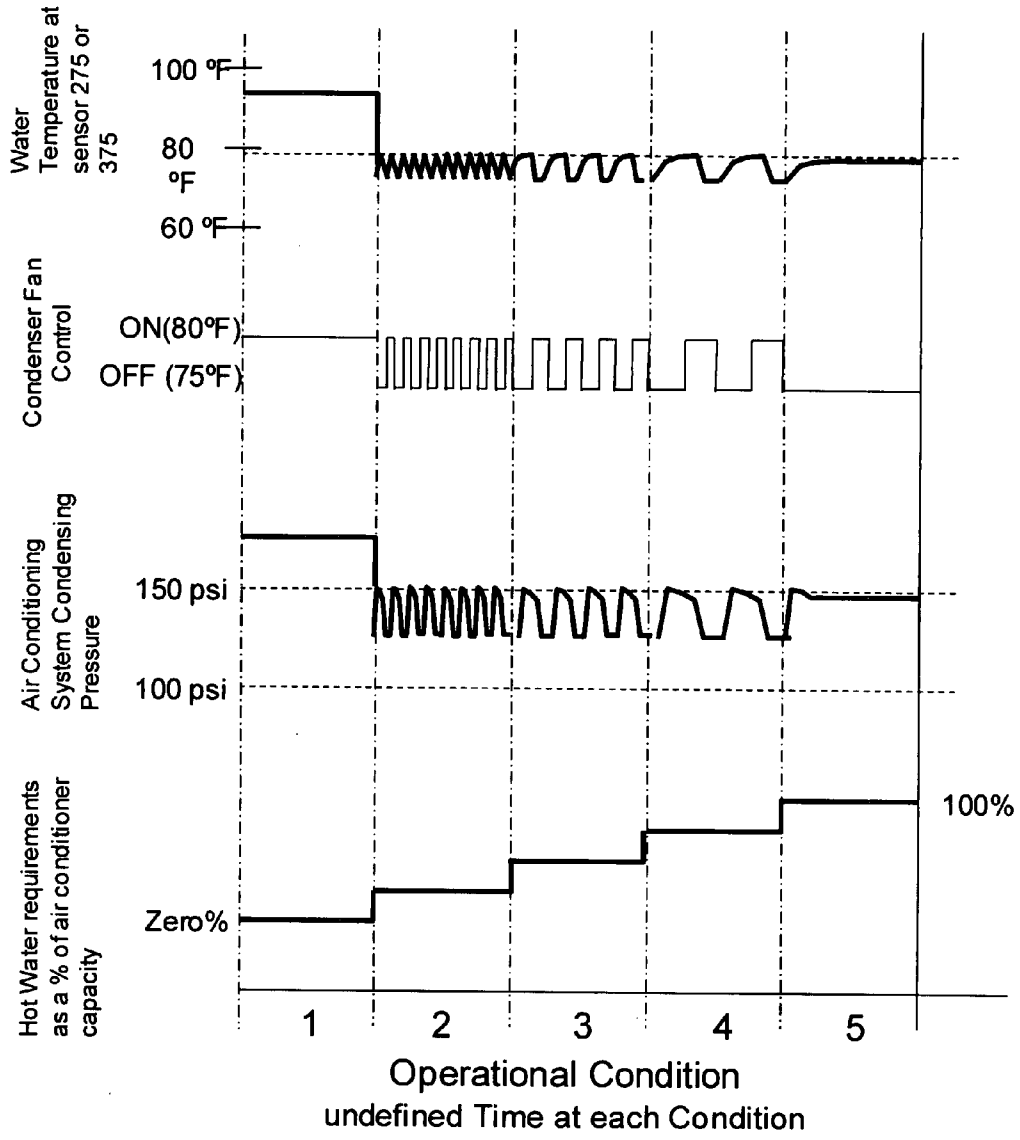
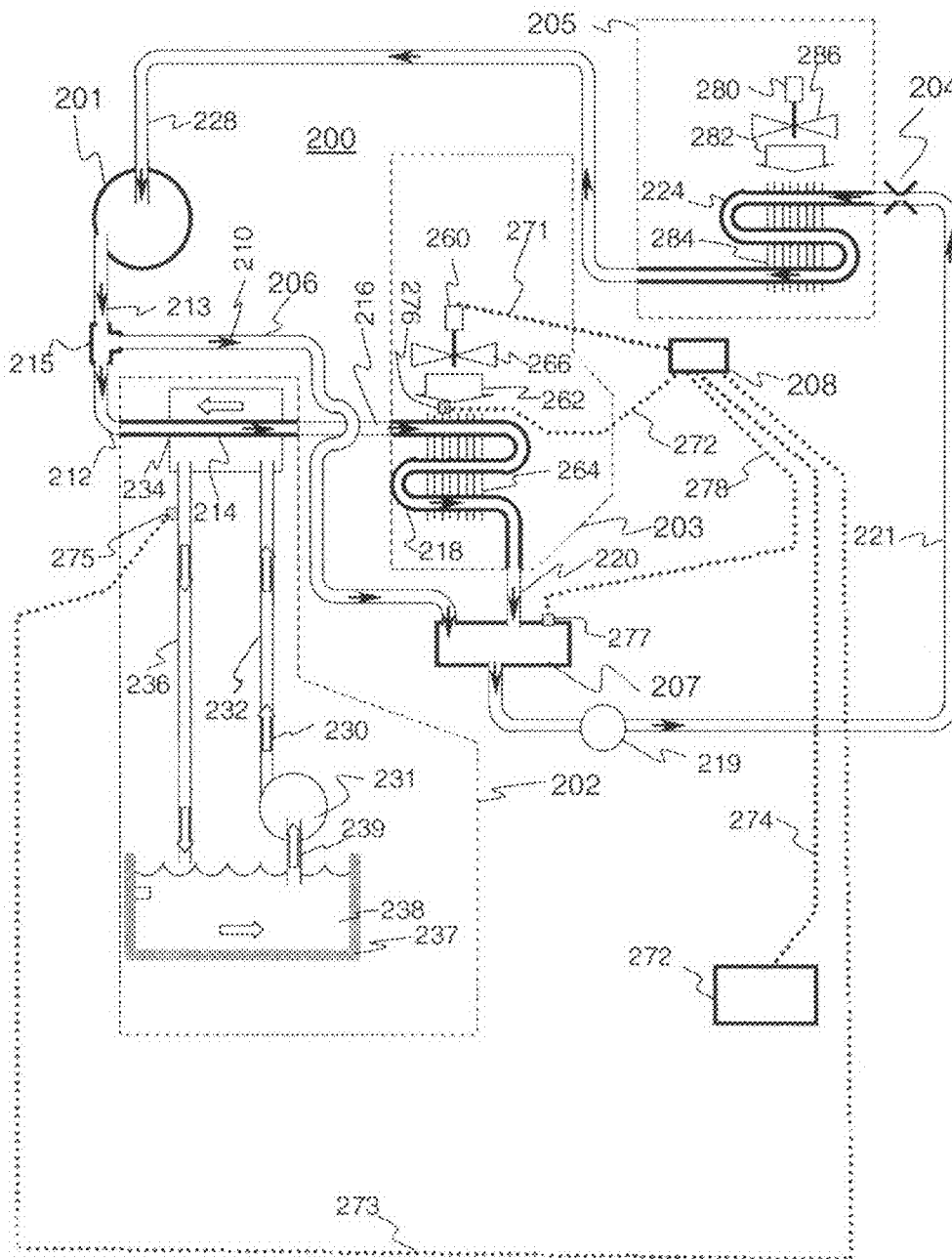

Fig 2A



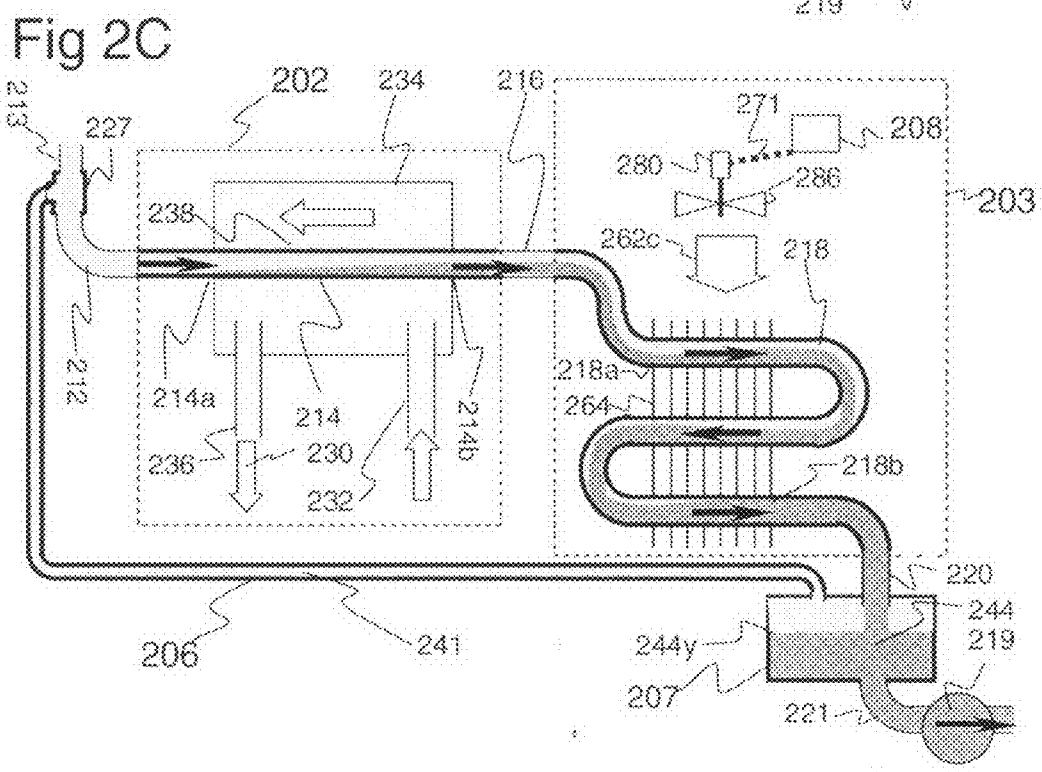
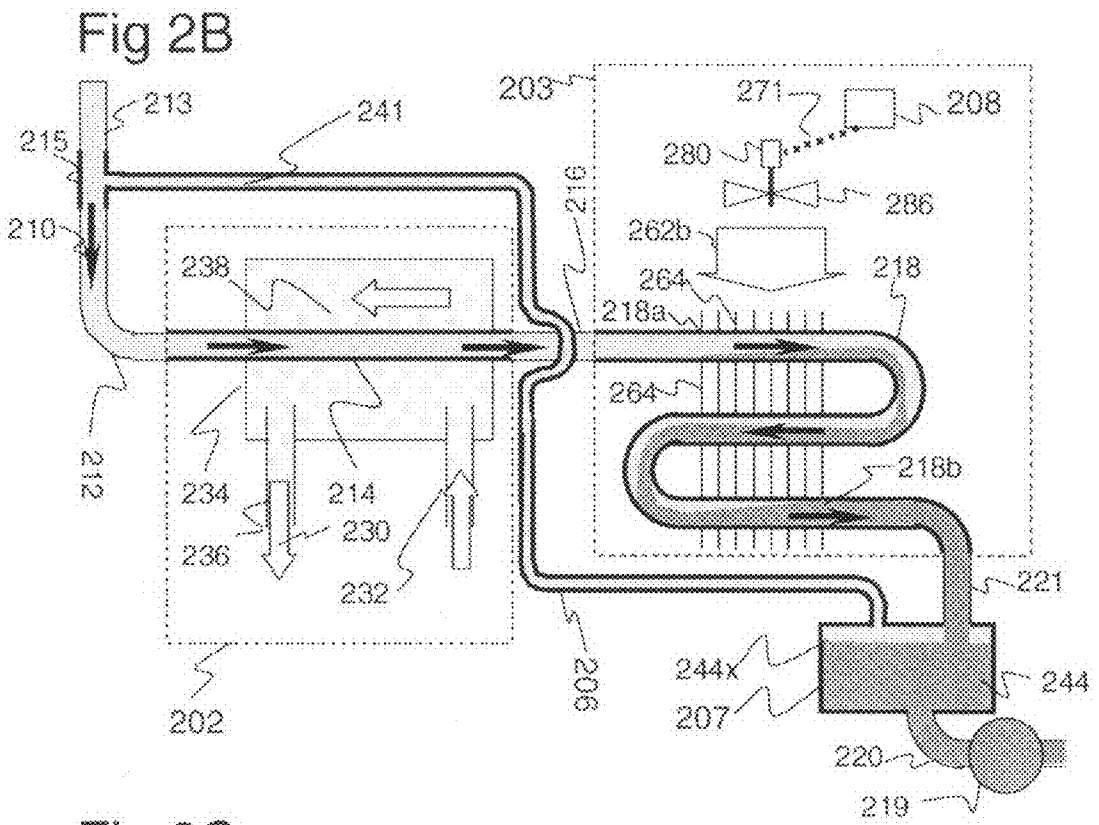

Fig 2D

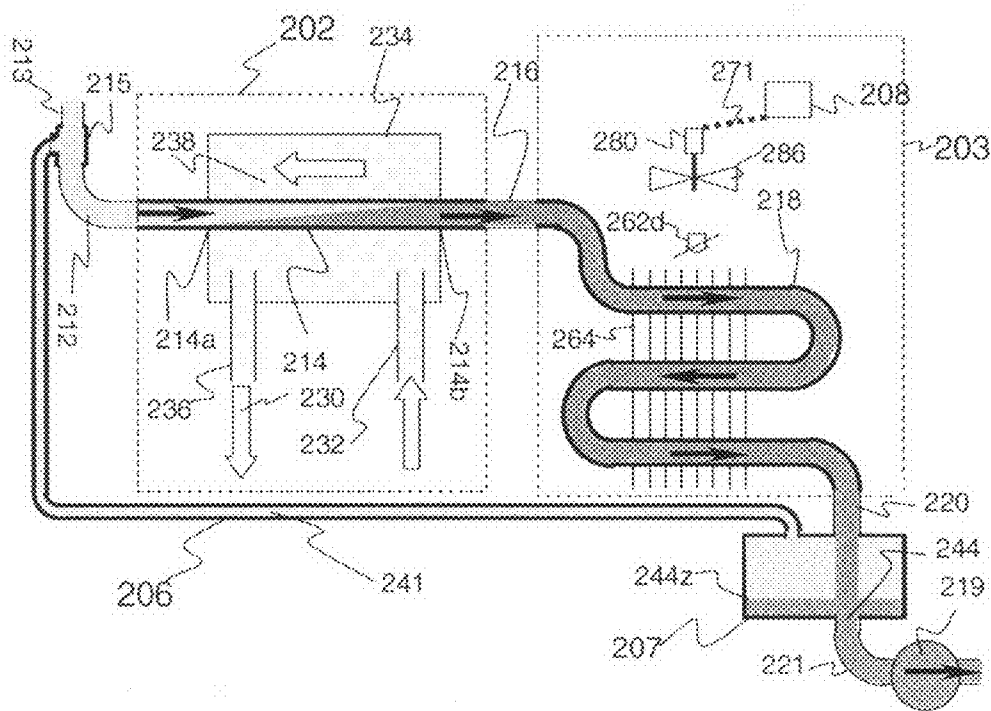

Fig 3A

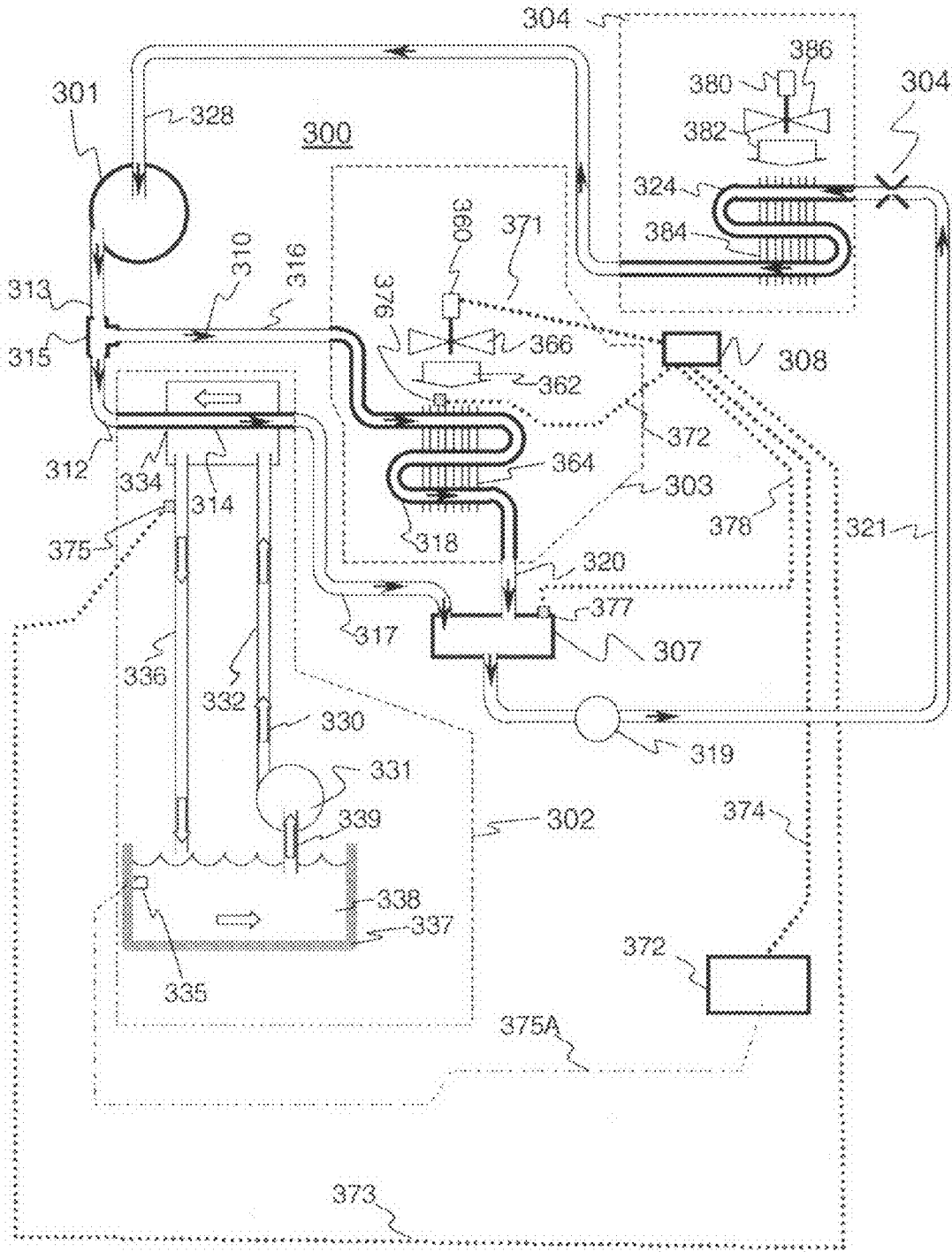

Fig 3D

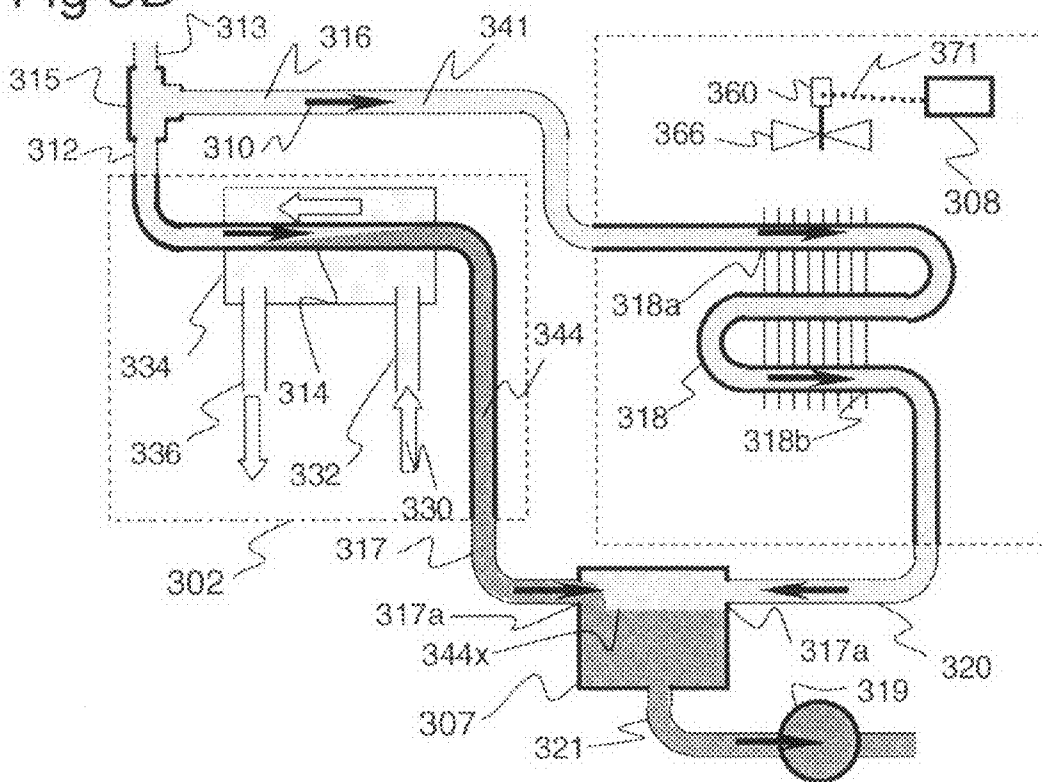

Fig 3E

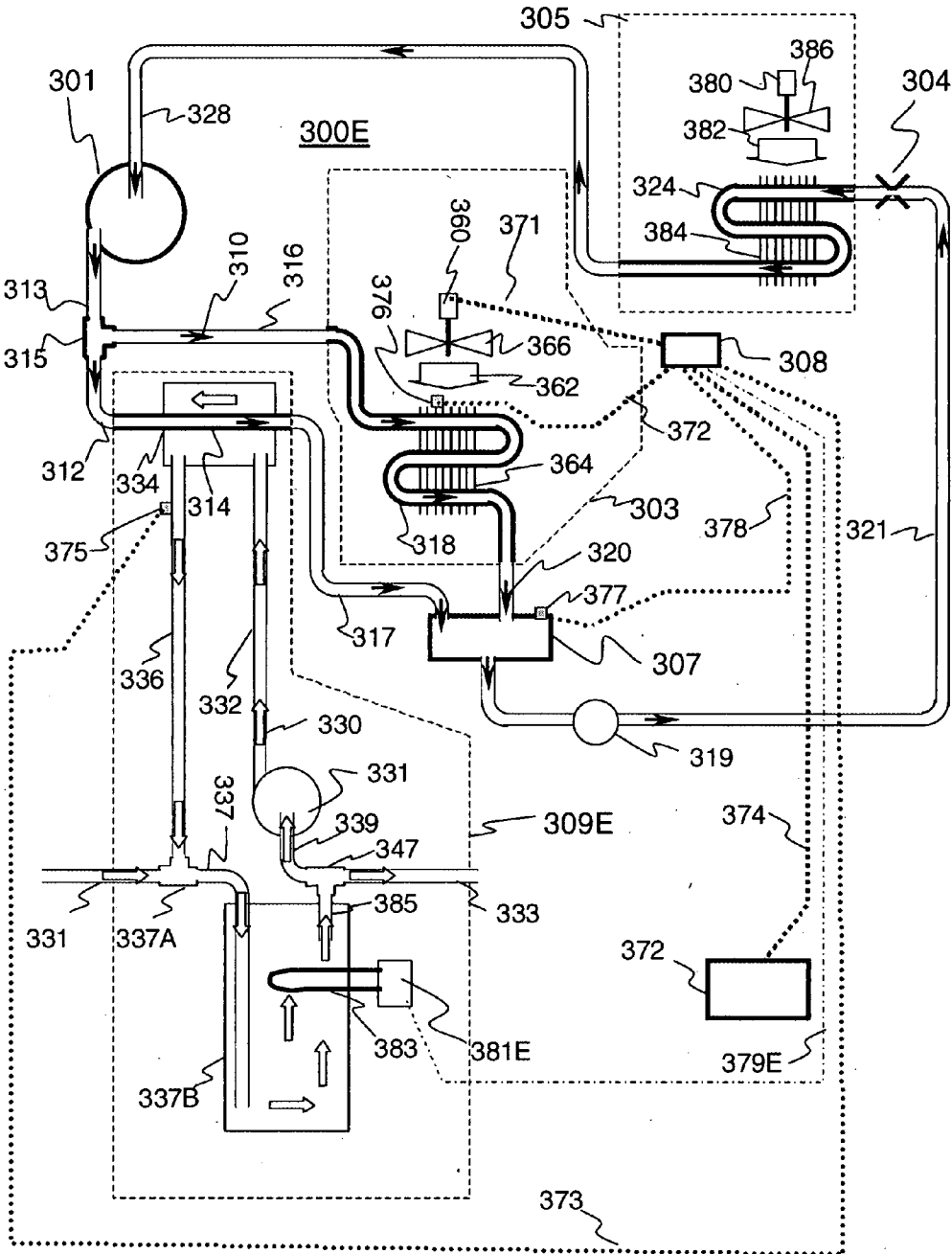

Fig 3F

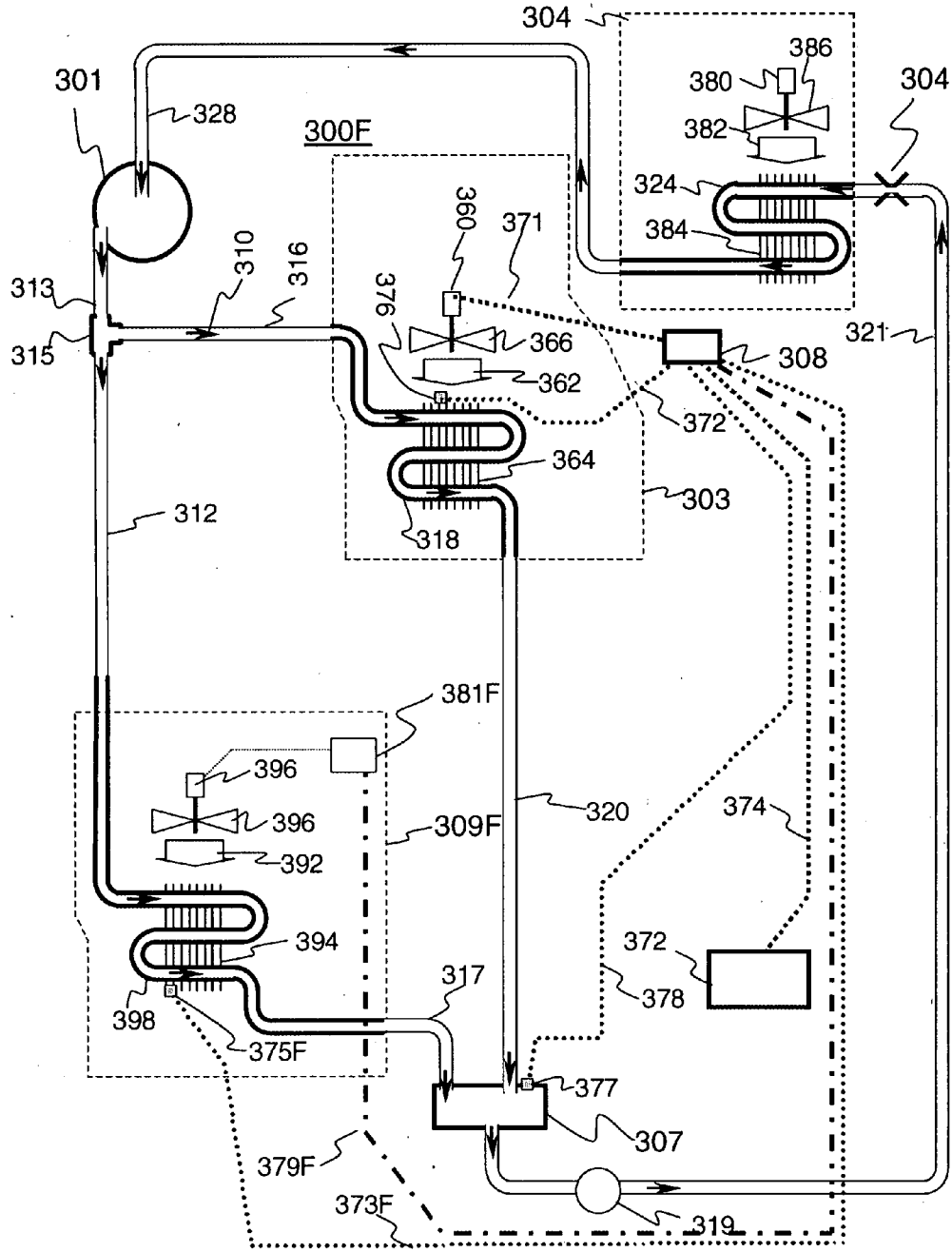

Fig 4A

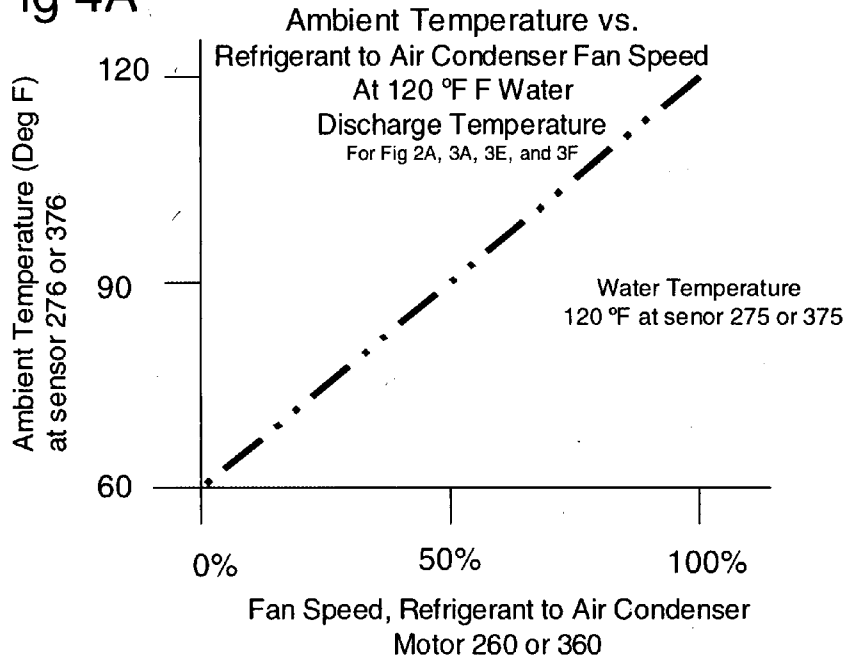

Fig 4B

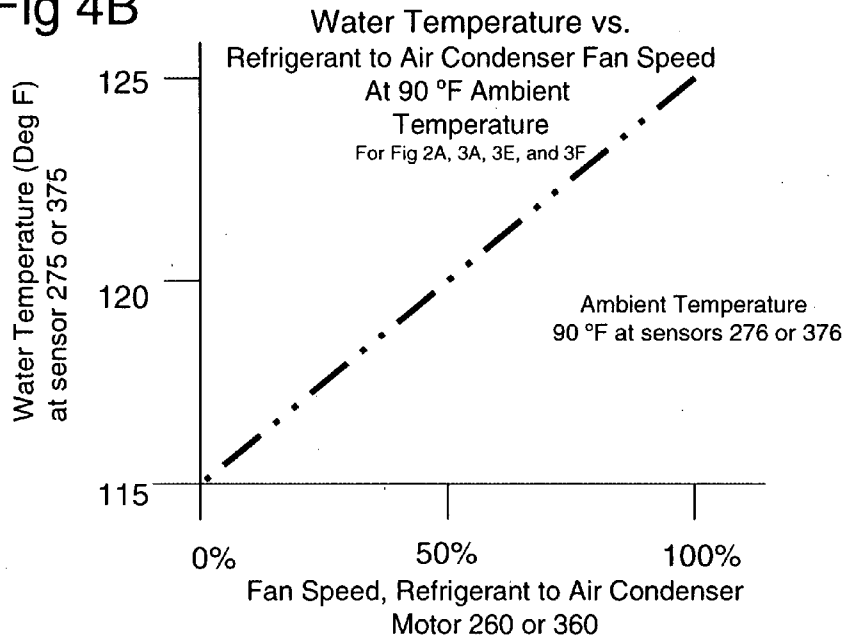

Fig 5A

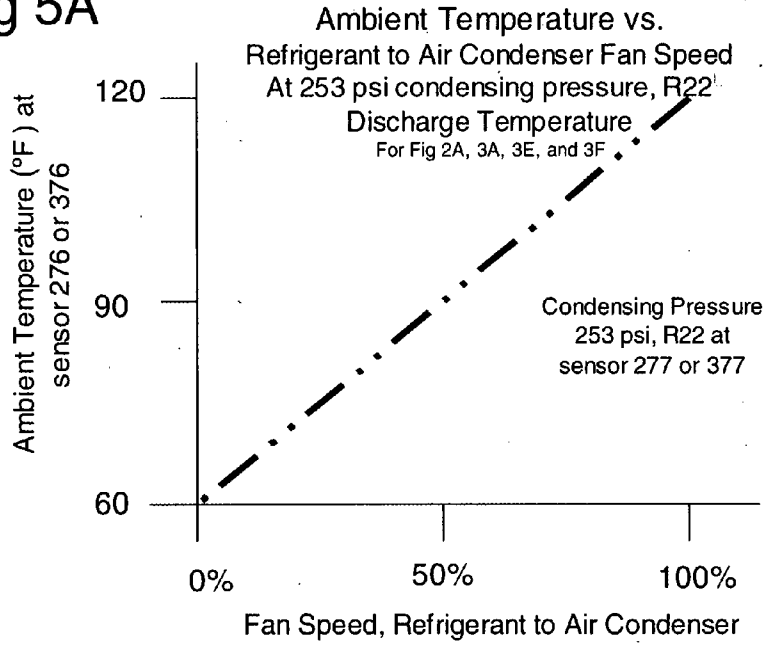

Fig 5B

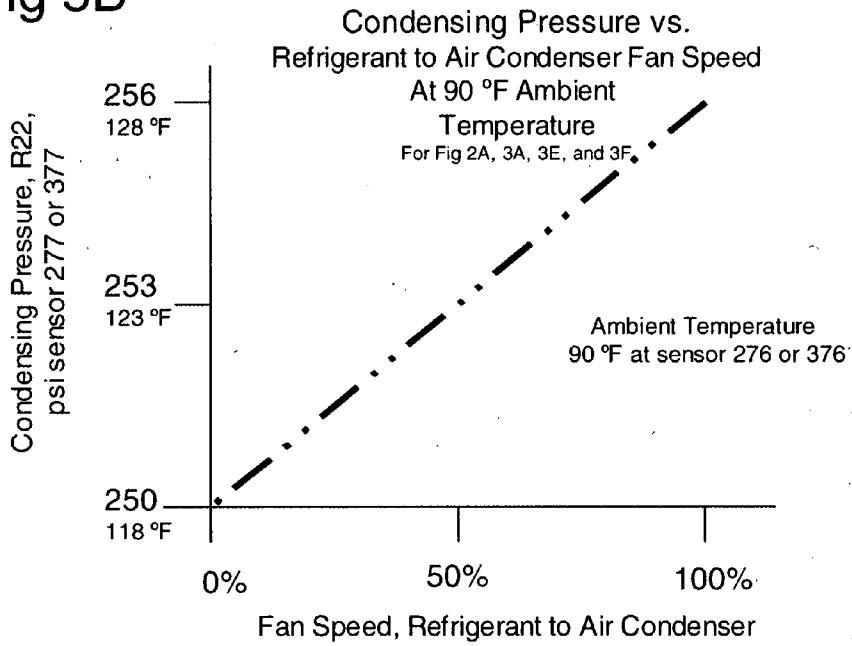
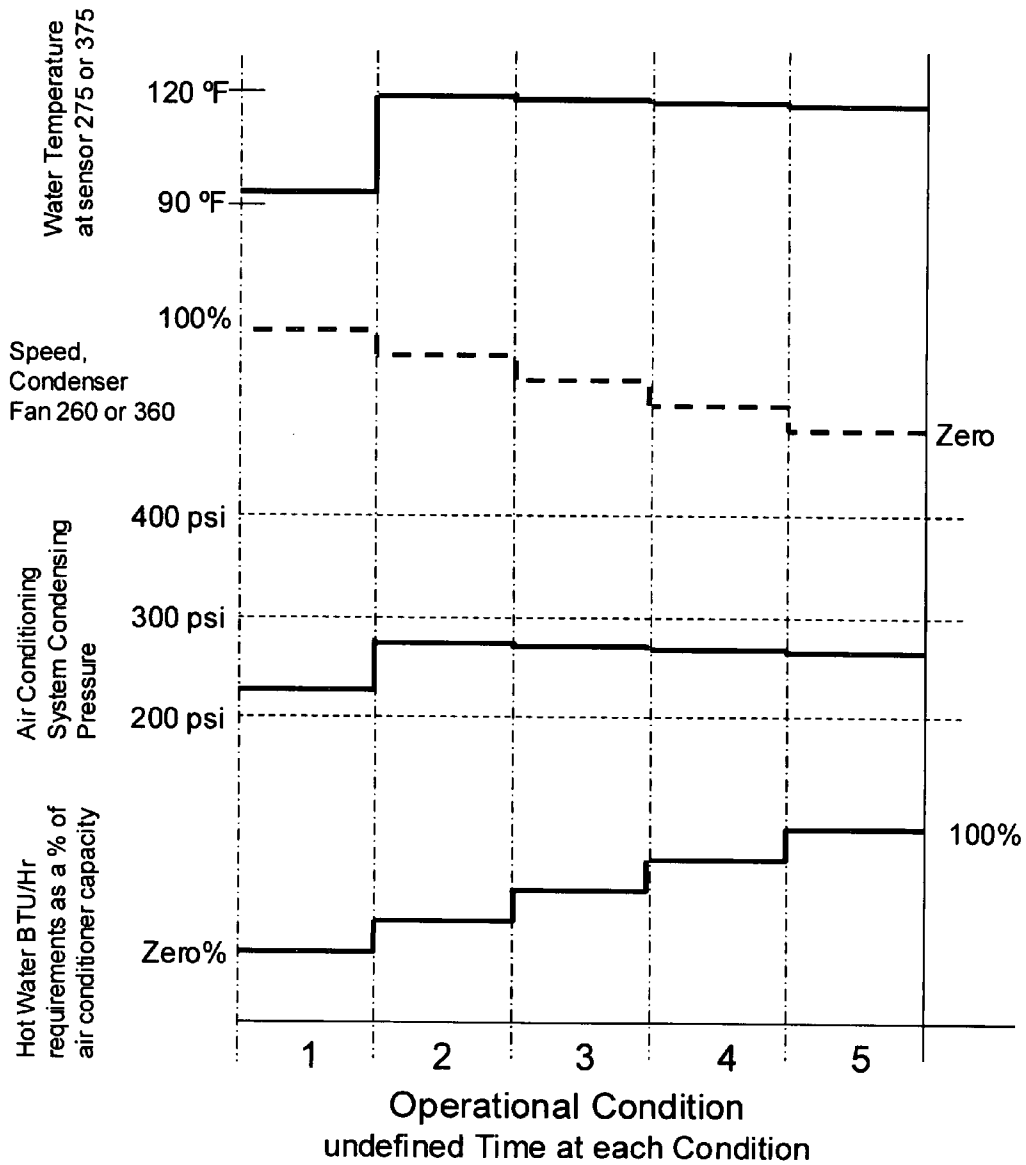

Fig 6A

Theoretical Outlet Water Temperature, Air Conditioning System Condensing Pressure, Condenser Fan Speed, and Hot Water BTU/Hr Requirements at various Operational Conditions for Fig For Fig 2A, 3A, 3E, and 3F with 90°F ambient at the refrigerant to air condenser, where the refrigerant to water condenser has the same capacity as the air conditioning system.



SYSTEM FOR CONTROLLED FLUID HEATING USING AIR CONDITIONING WASTE HEAT

TECHNICAL FIELD

[0001] The present invention relates to the recovery of waste heat from a refrigeration or an air conditioning system, to provide a heated fluid at a controlled, consistent temperature.

BACKGROUND

[0002] The use of a heater to warm swimming pool water is quite common among swimming pool owners. Many existing systems use electric, gas, or fuel oil-heating units, which are costly to operate. Attempts to utilize air conditioning waste heat to provide a safe, economical, and low energy consuming pool water heating system, such as shown in U.S. Pat. No. 3,976,123 issued to Davies, have not been commercially successful as previous systems did not maintain a constant discharge temperature, were inefficient to operate, and could cause equipment damage.

SUMMARY OF THE INVENTION

[0003] It is a general object of the present invention to provide a pool water heater that uses the waste heat from a refrigeration or an air conditioning system to heat pool water, or other fluids, to useful and desired temperatures, and to do such water heating with consistent, controlled output water temperatures, with optimum air conditioning system efficiency, and without equipment damage.

[0004] This and other objects and features are provided, in accordance with one aspect of the present invention, by an air conditioning system comprising a compressor connected to a first condenser and to a second condenser, connected in parallel or in series. The condensers and the compressor are connected to an accumulator, the accumulator connected to an expansion valve, the expansion valve connected to an evaporator, and the evaporator connected to the compressor. A pump draws water from a pool of water and supplies the water to the first condenser and then the water is returned to the pool. A control system adjusts the thermal performance of the second condenser to increase or decrease the condensing pressure and condensing temperature to heat the water to the desired temperature, based on the readings of two sensors, pressure and/or temperature, while the accumulator supplies the proper amount of liquid refrigerant to the expansion valve during all phases of operation. Other applications are presented for hot water heating and clothes drying.

BRIEF DESCRIPTION OF THE DRAWINGS

[0005] FIG. 1A shows a prior art air conditioning waste heat recovery system for heating pool water; FIG. 1B, 1C, and 1D show a partial enlargement of FIG. 1A and show the condition of the hot high temperature gaseous and liquid refrigerant with no pool water heating, partial pool water heating with the system charged with no pool water heating, and partial pool water heating with system charged with full pool water heating, respectively;

[0006] FIG. 1E shows Theoretical Outlet Water Temperature, Air Conditioning System Condensing Pressure, Condenser Fan ON/OFF, and Hot Water Requirements at various Operational Conditions;

[0007] FIG. 2A shows a first embodiment of the present invention air conditioning waste heat recovery system for heating pool water where the condensers are connected in series to an accumulator with a pressure equalization line between the compressor and accumulator, and the thermal performance of refrigerant-to-air condenser is controlled by adjusting its fan speed; FIG. 2B, 2C, and 2D show a partial enlargement of FIG. 2A, and show the condition of the hot high temperature gaseous and liquid refrigerant with no pool water heating, partial pool water heating, and maximum pool water heating, respectively;

[0008] FIG. 3A shows a second embodiment of the present invention air conditioning waste heat recovery system for heating pool water Where the condensers are connected in parallel between the compressor and accumulator and the thermal performance of refrigerant-to-air condenser is controlled by adjusting its fan speed; FIG. 3B, 3C, and 3D show a partial enlargement of FIG. 3A, and show the condition of the hot high temperature gaseous and liquid refrigerant with no pool water heating, partial pool water heating, and maximum pool water heating, respectively;

[0009] FIG. 3E is similar as FIG. 3A except the pool water heater is replaced by domestic or commercial hot water heating;

[0010] FIG. 3F is similar as FIG. 3A except the pool water heater is replaced by clothes dryer heating;

[0011] FIG. 4A and 4B show the control graphs for controlling the water temperature from the refrigerant-to-water condenser using ambient air temperature at the refrigerant-to-air condenser and exit water temperature at the refrigerant-to-water condenser to modulate fan motor speed in FIG. 2A and 3A and associated Figures;

[0012] FIG. 5A and 5B show the control graphs for controlling the water temperature from the refrigerant-to-water condenser using ambient air temperature at the refrigerant-to-air condenser and the system condensing pressure to modulate fan motor speed in FIG. 2A and 3A and associated Figures;

[0013] FIG. 6A shows Theoretical Outlet Water Temperature, Air Conditioning System Condensing Pressure, Condenser Fan Speed, and Hot Water Requirements at various Operational Conditions.

DETAILED DESCRIPTION

[0014] The use of air conditioning waste heat to heat swimming pool water has been demonstrated and is well know in the art. Davies discloses a system for controlled heating of pool water using waste heat of an air conditioner where the refrigerant-to-air condenser fan is cycled on and off in response to a sensor monitoring the temperature of the water exiting the refrigerant-to-water condenser. If the water temperature is below the Fan Off Set Point, the air conditioning condenser fan will be turned off, increasing the condensing pressure and temperature, increasing the amount of heat going into the refrigerant-to-water condenser, increasing the temperature of the water exiting refrigerant-to-water condenser. When the water temperature reaches the Fan On Set Point, which is higher than the Fan Off Set Point, the air conditioning fan will be turned on, decreasing the condensing pressure and temperature, reducing the amount of heat going into the refrigerant-to-water condenser, lowering the temperature of the water exiting refrigerant-to-water condenser. However, there are a number of inherent disadvantages present in this and other prior art systems. The cycling of the

condenser fan is a poor practice as the rate of cycling can become too high, burning out the condenser fan motor. Cycling of the condenser fan increases as the water heating BTU/hr load decreases as when the inlet water temperature approaches the Fan Off Set Point. Increasing the temperature separation between the Condenser Fan On and Off Set Points will reduce the instances of motor burn out but increases the temperature swing in the outlet temperature of the water exiting the refrigerant-to-water condenser which is unacceptable in many applications like domestic hot water heating.

[0015] Davies states "In operation, the transfer of heat to the pool water does not interfere with the refrigeration and cooling capabilities of refrigeration loop". This is a common false belief, because it is assumed that the air conditioning system is more efficient due to the additional condensing capacity of the refrigerant-to-water condenser. But in fact, a 15% degradation has been observed with a small, 1-ton pool water refrigerant-to-water condenser installed on a 3-ton air conditioning system. The degradation is caused by the refrigerant-to-water condenser, which when in operation takes liquid refrigerant from the refrigerant-to-air condenser, disrupting the balance of liquid refrigerant in the system, allowing hot gaseous refrigerant to reach the air conditioner's expansion valve and evaporator. Larger degradations will occur if larger refrigerant-to-water condensers are used, which is one reason why prior air pool water heaters use smaller refrigerant-to-water condensers. The air conditioning system is usually charged with refrigerant without pool water heating. With just the refrigerant-to-air condenser running, refrigerant is added until a solid column of liquid exits the refrigerant-to-air condenser. The solid column of refrigerant liquid can be seen in a sight glass installed after the condenser and the solid column of refrigerant liquid keeps high pressure gaseous refrigerant out of the evaporator, which would degrade the operation of the evaporator. When the pool water is turned on, refrigerant is condensed in the refrigerant to-water condenser and this amount of liquid is removed from the refrigerant-to-air condenser allowing high pressure gaseous refrigerant to reach the expansion valve and evaporator. Gaseous refrigerant will now be seen in the sight glass. The result is the operational efficiency of the air conditioning system is lowered. The amount of gaseous refrigerant reaching the expansion valve and evaporator is dependent upon the amount of refrigerant being condensed in the refrigerant-to-water condenser. Charging the air conditioner when the pool heater is running will keep the refrigerant liquid column up to the expansion valve and evaporator while water is being heated by the refrigerant-to-water condenser. But when the pool heater is turned off excess liquid refrigerant will pass thru the evaporator to the compressor, destroying the compressor, as the compressor cannot compress a liquid. A larger pool water refrigerant-to-water condenser will increase the risk of compressor damage, which is why they are sized to the small side. Air conditioning inefficiency due to high pressure gaseous refrigerant reaching the evaporator and compressor damage risks are additional problems that have limited the use of air conditioning waste heat to heat pool water or other fluids.

[0016] Referring now to FIG. 1A, a prior art air conditioning waste heat recovery system for heating pool water is shown generally as 100. The air conditioning waste heat recovery system comprises a compressor 101, a pool water condenser 102, a refrigerant-to-air condenser 103, an expansion valve 104, an air to refrigerant evaporator 105 and refrigerant-to-air fan motor controller 108. The refrigerant flow is

shown by arrows 110. Compressor 101 is connected to and supplies gaseous high pressure refrigerant-to-water condenser 134 condensing line 114 with refrigerant line 112, the refrigerant-to-water condenser 134 condensing line 114 is connected to and supplies high pressure gaseous and/or liquid refrigerant to refrigerant-to-air condenser 103 refrigerant line 118 with refrigerant line 116, the refrigerant-to-air condenser 103 refrigerant line 118 supplies high pressure liquid refrigerant to expansion valve 104 with refrigerant line 121, the expansion valve 104 supplies low pressure liquid refrigerant to evaporator 105 refrigerant line 124, the evaporator 105 refrigerant line 124 supplies low pressure gaseous refrigerant to compressor 101 with refrigerant line 128. The pool water flow is shown by arrows 130. Pump 131 is connected to and draws pool water 138 from pool 137 with line 139, pump 131 is connected to and supplies the pool water 138 to the refrigerant-to-water condenser 134 with water line 132, the water condenser 134 puts pool water 138 in contact for heat exchange with refrigerant line 114 which heats the pool water 138, the water condenser 134 supplies heated water to the pool 137 with water line 136. The waste heat recovery system refrigerant-to-air condenser 103 consists of a refrigerant line 118 with thermally connected fins 164, fan motor 160 with fan blades 166 that blow ambient air 162 across the fins 164, heating the ambient air 162. The waste heat recovery system expansion valve 104 causes the high pressure liquid refrigerant to become low pressure liquid refrigerant. The waste heat recovery system air to refrigerant evaporator 105 consists of a refrigerant line 124 with thermally connected fins 184, fan motor 180 with fan blades 186 which blow interior home air 182 across fins 184, cooling the interior home air 186, supplying low pressure gaseous refrigerant 141 to compressor 201. Refrigerant-to-air fan motor controller 108 reads the temperature of the exit water at sensor 175 with electrical line 173 and turns fan motor 160 off once the predefined exit water temperature is reached with electrical line 171. Now, all of the condensing must happen at the refrigerant-to-water condenser 134 refrigerant line 114 which increases the condensing pressure and temperature, heating the pool water 138 to a higher temperature. Fan motor controller 108 continues to read the exit water temperature with sensor 175 and will turn fan motor 160 back on when the exit water temperature increases to the predefined Fan ON temperature. Condensing will now occur in both condensers, lowering the condensing pressure and temperature, heating the pool water 138 to a lower temperature. If the pool water 138 temperature drops below the predefined Fan OFF set point, the OFF/ON cycle will repeat. The in home thermostat 172 tells fan motor controller 108 when system 100 is running.

[0017] Referring now to FIG. 1B, 1C, and 1D, partial enlargements of FIG. 1A, where refrigerant lines 112, 114, 116, 118, and 121 are shown coming to, through, and exiting pool water and refrigerant-to-air condenser 103 at various operational conditions. Refrigerant flow direction is shown by arrows 110.

[0018] Referring now to FIG. 1B where the pool water condenser is not being used and there is no pool water flow. Only the refrigerant-to-air condenser 103 is in operation and it is supporting the full air conditioning load. Liquid refrigerant 144 is only condensed in the refrigerant-to-air condenser 103. Condensing starts at point 118a when the gaseous high pressure, high temperature refrigerant 141 comes in contact for heat exchange with the portion of refrigerant line 118 that is in contact for heat exchange with the thermally

conductive fins 164 that are cooled by ambient air 162. Condensing basically ends at point 118b as refrigerant line 118 continues past thermally conductive fins 164. Approximately one half of the condenser volume between point's 118a and 118b are filled with liquid refrigerant 144. The air conditioning system is normally charged with refrigerant with just the refrigeration to air condenser running, and charging is stopped when the outlet of the refrigerant-to-air condenser is solid liquid as seen in sight glass 119.

[0019] Referring now to FIG. 1C, where both the pool water condenser 102 and refrigerant-to-air condenser 103 are in operation. Pool water flow is shown by arrows 130. Liquid refrigerant 144 is condensed in both condensers. Condensing starts at point 114a when the gaseous high pressure, high temperature refrigerant comes in contact for heat exchange with the portion of refrigerant line 114 that is in contact for heat exchange with and cooled by pool water 138. Now there is liquid refrigerant in both condensers and since the system was charged with only the refrigeration to air condenser 103 running, there is not enough refrigerant in the system to allow a solid column of liquid exiting the refrigerant-to-air condenser 103 as seen in sight glass 119. Now both gaseous high pressure refrigerant 141 and liquid refrigerant 144 reach the expansion valve 104 and air to refrigerant evaporator 105, reducing system efficiency

[0020] Referring now to FIG. 1D, where the air conditioning system has been charged with both the pool water condenser 102 and the refrigerant-to-air condenser 103 running. Now there is a solid column of liquid refrigerant 144 exiting the refrigerant-to-water condenser 134 and there is no high pressure gas 141 reaching the expansion valve 104 or the air to refrigerant evaporator 105, as shown in sight glass 119, for proper operational efficiency. However, when the pool water is turned off, the refrigerant liquid volume will revert to that of FIG. 1B and the liquid refrigerant volume difference between FIG. 1D and FIG. 1B will go into the air to refrigerant evaporator 105 and on to the compressor 101. Any liquid refrigerant 144 reaching the compressor 101 will cause severe damage and is dangerous.

[0021] Referring now to FIG. 1E, where theoretical Outlet Water Temperature, Air Conditioning System Condensing Pressure, Condenser Fan ON/OFF, and Hot Water Requirements at various Operational Conditions are shown for FIG. 1A. Five Operational Conditions are presented. The No. 1 Condition is for no pool water heating and the Hot Water requirement is zero. The air conditioning system is working normally as shown is FIG. 1B. The No. 5 Condition is for full pool water heating and the Hot Water requirement is 100%. Refrigerant condensing is taking place only in the refrigerant-to-water condenser. There is very little cycling of fan motor 160 under this condition and if the system was charged with refrigerant under this operating condition, the liquid refrigerant distribution would be as shown in FIG. 1D. If the system was charged with refrigerant under operation condition No. 1, the liquid refrigerant distribution would be as shown in FIG. 1C and hot gaseous refrigerant would reach the expansion valve, degrading air conditioning performance. The No. 2, No. 3, and No. 4 conditions are for 25%, 50% and 75% Hot Water requirements. Fan motor cycling decreases as the Hot Water requirements increase. Fan motor cycling at the lower Hot Water requirements will damage the typical refrigerant-to-air condenser fan motor. Fan motor cycling can be reduced by increasing the difference between the Fan ON and Fan OFF set points but this causes higher hot water temperature

differences between Fan ON and Fan OFF operation, which is unacceptable to other applications like hot water heating. If the system was charged with refrigerant under operating condition No 5, the liquid refrigerant distribution would be as shown in FIG. 1E, but excess liquid refrigerant, the liquid difference between FIG. 1D and 1E, would be available to damage the compressor. Under these conditions, the lower the hot water requirements, the more liquid refrigerant is available to damage the compressor. If the system was charged with refrigerant under operation condition No. 1, the liquid refrigerant distribution would be as shown in FIG. 1C and hot gaseous refrigerant would reach the expansion valve, degrading air conditioning performance. If the system is charged under conditions 2, 3, or 4, the system will only operate correctly at these specific operating conditions.

[0022] Accordingly, it is desirable to have an air conditioning waste heat system capable of heating pool water to desired temperatures with good operational efficiency, consistent output temperatures, and no equipment damage.

[0023] Referring now to FIG. 2A, an air conditioning waste heat recovery system for heating pool water according to the present invention is shown generally as 200, and comprises a compressor 201, a pool water condenser 202, a refrigerant-to-air condenser 203 where the condensers are connected in series; a pressure equalization line 206, an accumulator 207, a fan speed control 208 for the refrigerant-to-air condenser 203 fan motor 260, an expansion valve 204, and an air to refrigerant evaporator 205. Arrows 210 show the refrigeration flow. Compressor 201 is connected to and supplies gaseous high pressure refrigerant to refrigerant line tee 215 with refrigerant line 213, the refrigeration tee 215 is connected to and supplies gaseous high pressure, high temperature refrigerant to refrigerant-to-water condenser 234 condensing line 214 with refrigerant line 212, the refrigerant-to-water condenser 234 condensing line 214 is connected to and supplies gaseous and or liquid refrigerant-to-air condenser 203 refrigerant line 218 with refrigerant line 216, the refrigerant-to-air condenser 203 refrigerant line 218 supplies high pressure liquid refrigerant to accumulator 207 with refrigerant line 220. The tee 215 also supplies gaseous high pressure refrigerant to accumulator 207 with pressure equalization line 206. The accumulator 207 is connected to and supplies high pressure liquid refrigerant to expansion valve 204 with refrigerant line 221, the expansion valve 204 supplies low pressure liquid refrigerant to evaporator 205 refrigerant line 224, the evaporator 205 refrigerant line 224 supplies low pressure gaseous refrigerant to the compressor 201 with refrigerant line 228. The pool water condenser 202 water flow is shown by arrows 230. Pump 231 is connected to and draws pool water 238 from pool 237 with line 239, the pump 231 is connected to and supplies the pool water 238 to the refrigerant-to-water condenser 234 with water line 232, the water condenser 234 puts the pool water 238 in contact for heat exchange with the refrigerant line 214 which heats the pool water 238, the water condenser 234 supplies heated pool water 238 to the pool 237 with water line 236. The waste heat recovery system refrigerant-to-air condenser 203 consists of a refrigerant line 218 with thermally connected fins 264, fan motor 260 with fan blades 266 that blow ambient air 262 across the fins 264, heating the ambient air 262. Fan speed controller 208 is connected to and adjusts fan motor 260 speed from zero to 100%, which controls the amount of condensation taking place in the refrigerant-to-air condenser 203 and raises or lowers the condensing pressure in both condensers to obtain

the desired water temperature exiting the refrigerant-to-water condenser 234. The waste heat recovery system expansion valve 204 causes the high pressure liquid refrigerant to become low pressure liquid refrigerant. The waste heat recovery system air to refrigerant evaporator 205 consists of a refrigerant line 224 with thermally connected fins 284, fan motor 280 with fan blades 286 which blow interior home air 282 across the fins 284, cooling the interior home air 286 and supplying gaseous refrigerating to compressor 201 by refrigerant line 228. The control system 208 that modulates the refrigerant-to-air condenser 203 fan 206 will be discussed in detail later.

[0024] Referring now to FIG. 2B, 2C, 2D, partial enlargements of FIG. 2A, where refrigerant lines 213, 212, 214, 215, 216, 218, and 221 are shown coming to, through, and exiting pool water condenser 202, refrigerant-to-air condenser 203 and accumulator 207; and pressure equalization line 206 is connected between tee 215 a head of pool water refrigerant-to-water condenser 202 and the accumulator 207. Arrows 210 show refrigerant flow direction.

[0025] Referring now to FIG. 2B, the pool water condenser 202 is not being used and there is no pool water flow. The refrigerant-to-air condenser 203 is in operation and its condensing capacity is controlled by fan motor controller 208 running fan motor 280 at 100 percent of fan capacity, because water heating is not desired. Liquid refrigerant 244 is condensed only in the refrigerant-to-air condenser 203. Condensing starts at point 218a when the gaseous high pressure, high temperature refrigerant 241 comes in contact for heat exchange with the portion of refrigerant line 218 that is in contact for heat exchange with the cooling fins 264. Condensing basically ends at point 218b as refrigerant line 218 continues past thermally conductive fins 264. The condensing volume between point's 218a and 218b are approximately one half filled with liquid refrigerant. The air conditioning system has been charged with the refrigerant with just the pool water condenser 202 running as shown in FIG. 2D, which is the maximum liquid refrigerant condition and charging, stopped when the outlet of the refrigerant-to-air condenser 203 is solid liquid as seen in sight glass 119. The accumulator 207 has the capacity to receive the unneeded liquid refrigerant when the pool water condenser is not in operation and pressure equalization line 206 allows accumulator volume changes without forcing the excess liquid refrigerant through the system, to avoid compressor damage.

[0026] Referring now to FIG. 2C, where both the pool water condenser 202 and refrigerant-to-air condenser 203 are both in operation. Arrows 230 show pool water flow. Condensing starts at point 214a when the gaseous high pressure, high temperature refrigerant 241 comes in contact for heat exchange with the portion of refrigerant line 214 that is in contact for heat exchange with and cooled by the pool water 238. Now there is liquid refrigerant in both condensers and since the system was charged with only the pool water condenser 202 running, there is enough liquid refrigerant 244 in the accumulator 207 to supply liquid refrigerant 244 so that a continuous column of liquid exits the accumulator 207 as seen in sight glass 219. Now only liquid refrigerant 244 reaches the expansion valve 204 and air to refrigerant evaporator 205, maintaining system efficiency. Fan motor controller 208 adjusts fan motor 260 speed between zero and 100%, which increases or decreases the condensing pressure and

temperature to maintain the desired water temperature at the point 214b in the pool water refrigerant-to-water condenser 202.

[0027] Referring now to FIG. 2D, where the pool water condenser 202 is running at 100% and carrying the full air conditioning load. Refrigerant-to-air condenser 203 fan motor 280 has been turned off by motor controller 208. This is the maximum water heating capability of the waste heat recovery system 200 and all of the condensing energy is going into heating the pool water. Arrows 230 show pool water flow. Condensing starts at point 214a when the gaseous high pressure, high temperature refrigerant 241 comes in contact for heat exchange with that portion of refrigerant line 214 that is in contact for heat exchange with and cooled by the pool water 238. Now there is the maximum liquid refrigerant in both condensers and this is the operational condition for proper charging of the air conditioning waste heat recovery system for heating pool water. Now there is enough liquid refrigerant 244 in the accumulator 207 to supply liquid refrigerant 244 to allow a solid column of liquid to exit the accumulator 207 when pool water condenser 202 is not in operation and there is enough accumulator capacity to accept unneeded liquid refrigerant when pool water condenser 202 is running up to 100% of capacity. Since the accumulator maintains a constant liquid refrigerant supply to expansion valve 204 and the accumulator has the capacity to hold unneeded liquid refrigerant 244, the system works at peak efficiency and there is no risk of compressor damage.

[0028] Referring now to FIG. 2A again, fan 260 controller 208 receives inputs or sends outputs from water exit temperature sensor 275 by electrical line 273, from condensing pressure sensor 277 at accumulator 207 by electrical line 278, from ambient air temperature sensor 276 at refrigerant-to-air condenser 203 by electrical line 272, and controls fan motor 260 speed with control line 271. Controller 208 determines if water heating is needed and controller 208 turns on the air conditioning system by electrical line 274 to in home thermostat 272. Controller then adjusts the speed of fan 260 per control graphs shown in FIG. 4A and 4B to maintain the selected water exit temperature from refrigerant-to-water condenser 234 as read at sensor 275.

[0029] The size of the accumulator is dependent upon the sizes of the system condensers 234 and 203. Typically the accumulator volume must be at least equal to the volume delta between the liquid volume shown in FIG. 2B and the liquid volume shown in FIG. 2D between point 214a and the point where line 221 enters accumulator 207. This will guarantee that the expansion valve only sees liquid refrigerant under all stated operating conditions. A 5 to 10% additional accumulator volume is usually added as a safety factor.

[0030] Referring now to FIG. 3A, an air conditioning waste heat recovery system for heating pool water accordingly to the present invention is shown generally as 300 where the condensers are connected in parallel and the refrigerant-to-air condenser capacity is controlled by ambient air flow 362. The assembly 300 comprises a compressor 301, a pool water condenser 302, a refrigerant-to-air condenser 303, an accumulator 307, a fan speed control 308 for the refrigerant-to-air condenser 303, an expansion valve 304, and an air to refrigerant evaporator 305. Arrows 310 show the refrigeration flow. Compressor 301 is connected to and supplies gaseous high pressure refrigerant to refrigerant line tee 315 with refrigerant line 313, the refrigeration tee 315 is connected in parallel to and supplies gaseous high pressure refrigerant to both refrigerant

erant-to-water condenser 334 condensing line 314 with refrigerant line 312, and refrigerant-to-air condenser 303 condensing line 318 with refrigerant line 316. Both condensers supply high pressure gaseous and/or liquid refrigerant to accumulator 307 with refrigerant lines 317 and 320. Accumulator 307 supplies liquid refrigerant to expansion valve 305 and evaporator 304 with refrigerant line 321. Evaporator 304 supplies low pressure gaseous refrigerant to compressor 301 with refrigerant line 328. The pool water condenser 302 water flow is shown by arrows 330. Pump 331 is connected to and draws pool water 338 from pool 337 with line 339, the pump 331 is connected to and supplies the pool water 338 to the refrigerant-to-water condenser 334 with water line 332, the refrigerant-to-water condenser 334 puts the pool water 338 in contact for heat exchange with the refrigerant line 314 which heats the pool water 338, the refrigerant-to-water condenser 334 supplies heated water to the pool 337 with water line 336. The waste heat recovery system refrigerant-to-air condenser 303 consists of a refrigerant line 318 with thermally connected fins 364, fan motor 360 with fan blades 366 that blow ambient air 362 across the fins 364, heating the ambient air 362 and fan speed controller 308 which controls the amount of condensation taking place in the refrigerant-to-air condenser 303 by adjusting the amount of ambient air 362 blowing over the fins 364. The waste heat recovery system expansion valve 304 and air to refrigerant evaporator 305 operate in the conventional manner supplying low pressure gaseous refrigerating to compressor 301 by refrigerant line 328.

[0031] Referring now to FIG. 3B, 3C, and 3D, partial enlargements of FIG. 3A, where refrigerant lines 315, 313, 312, 314, 317, 316, 318, 320 and 321 are shown coming to, through, and exiting pool water condenser 302, refrigerant-to-air condenser 303 and accumulator 307. Both condensers are connected in parallel. Refrigerant flow is shown with arrows 310.

[0032] Referring now to FIG. 3B, pool water condenser 302 is not in operation and all condensing is occurring at the refrigerant-to-air condenser. Compressor 301 is connected to and supplies gaseous high pressure refrigerant 341 to refrigerant line tee 315 with refrigerant line 313, the refrigeration tee 315 is connected in parallel to and supplies gaseous high pressure refrigerant 341 to both refrigerant-to-water condenser 334 condensing line 314 with refrigerant line 312, and refrigerant-to-air condenser 303 condensing line 318 with refrigerant line 316. Both condensers supply high pressure gaseous 341 and liquid refrigerant 344 to accumulator 307 with refrigerant line 317 and 320, respectively. Accumulator 307 supplies liquid refrigerant 344 to expansion valve 305 and evaporator 304 with refrigerant line 321. The pool water condenser 302 is not being used and there is no pool water flow. The refrigerant-to-air condenser 303 is in operation and its condensing capacity is controlled by fan motor controller 308 running fan motor 360 at 100 percent of fan capacity. Liquid refrigerant 344 is condensed only in the refrigerant-to-air condenser 303. Condensing starts at point 318a when the gaseous high pressure, high temperature refrigerant 341 comes in contact for heat exchange with the portion of refrigerant line 318 that is in contact for heat exchange with the cooling fins 364. Condensing basically ends at point 318b as refrigerant line 318 continues past thermally conductive fins 364. Accumulator 307 accepts or supplies liquid refrigerant 344 as required, maintaining a constant liquid refrigerant flow to expansion valve 304 as shown in sight glass 319.

[0033] Referring now to FIG. 3C, where both the pool water condenser 302 and refrigerant-to-air condenser 303 are both in operation. Arrows 330 show pool water flow. Condensing starts at point 314a when the gaseous high pressure, high temperature refrigerant comes in contact for heat exchange with the portion of refrigerant line 314 that is in contact for heat exchange with and cooled by the pool water 338. Now there is liquid refrigerant in both condensers and since the system was charged with only the larger volume condenser running, there is enough liquid refrigerant 344 in the accumulator 307 to allow a solid column of liquid to exit the accumulator 307 as seen in sight glass 319. Now only liquid refrigerant 344 reaches the expansion valve 304 and air to refrigerant evaporator 305, maintaining system efficiency. Fan motor controller 308 adjusts fan motor 380 speed between zero and 100%, which increases or decreases the condensing pressure and condensing temperature to maintain the desired water temperature at the point 314b in the pool water condenser 302.

[0034] Referring now to FIG. 3D where only the pool water condenser 302 is running. Arrows 330 show pool water flow and refrigerant flow is shown by arrows 310. Condensing starts at point 314a when the gaseous high pressure, high temperature refrigerant comes in contact for heat exchange with the portion of refrigerant line 314 that is in contact for heat exchange with and cooled by the pool water 338. Fan motor controller 308 running fan motor 280 at zero percent of fan capacity, which makes all condensing take place in the pool water condenser 302. This is the maximum water heating condition. Accumulator 307 accepts or supplies liquid refrigerant as required, maintaining a constant liquid refrigerant flow to expansion valve 304 as shown in sight glass 319.

[0035] Referring now to FIG. 3E, which is similar to FIG. 3A except the pool water source has been replaced with a hot water heater. Fan 360 controller 308 receives inputs or sends outputs from water exit temperature sensor 375 by electrical line 373, from refrigerant-to-water condenser 334, from water heater control module 381E by electrical line 379E, from condensing sensor 377 at accumulator 307 by electrical line 378, from ambient air temperature sensor 376 at refrigerant-to-air condenser 303 by electrical line 372, and controls fan motor 360 speed with control line 371. Water heater control module 381 tells controller 308 that water heating is needed and the air conditioning system is turned on by electrical line 374 to in home thermostat 372. Controller then adjusts the speed of fan 360 per control graphs shown in FIG. 4A and 4B or FIG. 5A and 5B to maintaining the selected water exit temperature from refrigerant-to-water condenser 334 as read at sensor 375 or 377.

[0036] Referring now to FIG. 3F, which is similar to FIG. 3A except the pool water source has been replaced with a clothes dryer condenser. Fan 360 controller 308 receives inputs or sends outputs from refrigerant-to-air clothes dryer sensor 379F by electrical line 373F, from clothes dryer control module 381 F by electrical line 379F, from condensing pressure sensor 377 at accumulator 307 by electrical line 378, from ambient air temperature sensor 376 at refrigerant-to-air condenser 303 by electrical line 372, and controls fan motor 360 speed with control line 371. Clothes dryer control module 381 tells controller 308 that air heating is needed and the air conditioning system is turned on by electrical line 374 to in home thermostat 372. Controller 308 then adjusts the speed of fan 360 per control graphs shown in FIG. 4A and 4B or 5A and 5B to maintaining the selected air exit temperature from

clothes dryer condenser 309F as read at sensor 375F. Note that charts 4A, 4B, 5A and 5B are for controlling the water exit temperature and that these water exit temperatures must be replaced with the wanted clothes dryer air exit temperatures for proper control and operation.

[0037] Other applications could be to Pasteurize milk or beer using the waste heat from a Dairy or Brewery's refrigeration systems or Hospital hot water heating using the Hospital's air conditioning waste heat. These applications could be met year round as their refrigeration or air conditioning systems run year round. Most air conditioned factory or office complexes could have their fluid heating needs met using their refrigeration or air conditioning waste heat.

[0038] System charging of two condensers in parallel is done with only the condenser with the larger liquid requirement running. Typically, this is the refrigerant-to-air condenser 303 in FIG. 3A. However, there are instances where the other condensers may have the larger liquid requirement and in those cases, system charging must be done with only that condenser running. Charging is complete when the sight glass 319 is full of liquid.

[0039] The size of the accumulator for condensers connected in parallel is determined by subtracting the liquid requirements of each condenser when it alone is running as shown in FIG. 3B and FIG. 3D and plus an additional safety factor amount such as 1% of the system's liquid refrigerant volume. For the refrigerant-to-water condenser 334 the volume is typically equal to 1/2 of the volume between points 314a and 314b and the volume between points 314b and 317a as shown in FIG. 3D. For the refrigerant-to-air condenser 303, the refrigerant liquid volume is typically equal to 1/2 the volume between points 318a and 318b and the volume between points 318b and 321a as shown in FIG. 3B.

[0040] Referring now to FIG. 4A, a graph is shown of ambient temperature measured at sensor 276 or 376 at the refrigerant-to-air condenser 203 or 303 vs. refrigerant-to-air condenser fan speed for maintaining controlled exit water temperature from the pool water condenser 202 or 302 by controller 208 or 308 in FIG. 2A or FIG. 3A, respectively. As shown in the previous sentence, the last two digits of an item number are the same between FIG. 2A and FIG. 3A, and the first digit is either 2 or 3, respectively. From this point forward, this convention will apply unless otherwise noted. The graph in FIG. 4A is for an exit water temperature set point of 120° F. as read by sensor 275 at the pool water condenser 202 and an operational ambient temperature range from 60 to 120° F. as read by sensor 276. The 120° F. exit water temperature set point is chosen by the system operator. The operational ambient temperature range is the expected ambient temperature range at the refrigerant-to-air condenser. As the ambient temperature moves from 60 to 120° F., the fan speed will change from zero fan speed to 100% fan speed with a defined constant exit water temperature from the refrigerant-to-water condenser of 120° F.

[0041] Referring now to FIG. 4B, a graph is shown of exit water temperature from the refrigerant-to-water condenser as read at sensor 275 vs. refrigerant-to-air condenser fan speed for maintaining controlled exit water temperature from the refrigerant-to-water condenser as read at sensor 275. This graph is for the mid point ambient of 90° F. at the refrigerant-to-air condenser as read by sensor 276 and an exit water temperature from the refrigerant-to-water condenser range of 10° F. centered about the 120 degree set point. As the exit water temperature from the refrigerant-to-water condenser

moves from 115 to 125° F., the fan speed control will change from zero fan speed to 100% fan speed at a constant 90° F. ambient temperature at the refrigerant-to-air condenser.

[0042] The control formula for graphs 4A and 4B can be represented by the following mathematical formula:

$$[25+(T_{ambMP}-T_{amb})K_{amb}]+[25+(T_{wSP}-T_{wact})K_w]=\% \text{ fan speed at the refrigerant-to-air condenser.}$$

Where:

[0043] All temperatures are in ° F.

[0044] T_{amb} equals the ambient air temperature at the refrigerant-to-air condenser 276.

[0045] T_{ambMP} equals the mid point of expected ambient air temperatures at the refrigerant-to-air condenser.

[0046] T_{wact} equals the actual exit water temperature from the refrigerant-to-water condenser at sensor 275.

[0047] T_{wSP} equals exit water temperature set point desired from the refrigerant-to-water condenser.

[0048] K_{amb} equals a constant that sets the control sensitivity to changes in ambient temperature at the refrigerant-to-air condenser. The ambient air temperature at the refrigerant-to-air condenser has a second order effect on the actual exit water temperature from the refrigerant-to-water condenser and K_{amb} is set at -1.66, a relatively insensitive number.

[0049] K_w equals a constant that sets the control sensitivity to changes in exit water temperature from the refrigerant-to-water condenser. Since controlling the exit water temperature from the refrigerant-to-water condenser is the goal of this control and by definition is the first order effect, K_w is set at -10 for these graphs. The higher the K_{amb} and K_w values, the higher the control reaction to changes in temperature. In the values above, K_w is 16.66 times more sensitive to its temperature changes than K_{amb} . If the system has problems maintaining accurate exit water temperatures from the refrigerant-to-water condenser, K_w should be increased. If K_w is too high, the control will be too sensitive, causing rapid oscillations in fan speed. If K_w is too low, the control will be too insensitive, causing problems maintaining accurate exit water temperatures from the refrigerant-to-water condenser. K_w values from -10 to -20 are usually acceptable.

[0050] The exit water temperature at sensor 275 should run within 2 degrees of the T_{wSP} temperature. If the exit water temperature at sensor 275 runs to the low side, increase T_{wSP} . If, the exit water temperature at sensor 275 runs to the high side, decrease T_{wSP} .

[0051] Referring again to FIG. 4A and FIG. 4B, it is possible to change sensor 275 or 375 from reading the water exit temperature to reading the system condensing temperature and to get similar control results with all other conditions being the same.

[0052] The control formula for graphs 4A and 4B for using system condensing temperature instead of water exit temperature can be represented by the following mathematical formula:

$$[25+(T_{ambMP}-T_{amb})K_{amb}]+[25+(T_{conTSP}-T_{conTact})K_{conT}]=\% \text{ fan speed at the refrigerant-to-air condenser.}$$

Where:

[0053] All temperatures are in ° F.

[0054] T_{amb} equals the ambient air temperature at the refrigerant-to-air condenser 276.

[0055] T_{ambMP} equals the mid point of expected ambient air temperatures at the refrigerant-to-air condenser.

[0056] $T_{conT act}$ equals the actual system condensing temperature from the refrigerant-to-water condenser at sensor 275.

[0057] $T_{conT SP}$ equals system condensing temperature set point need to produce the desired exit water temperature from the refrigerant-to-water condenser.

[0058] K_{amb} equals a constant that sets the control sensitivity to changes in ambient temperature at the refrigerant-to-air condenser. The ambient air temperature at the refrigerant-to-air condenser has a second order effect on the actual exit water temperature from the refrigerant-to-water condenser and K_{amb} is set at -1.66 , a relatively insensitive number.

[0059] K_{conT} equals a constant that sets the control sensitivity to changes in system condensing temperature which affects exit water temperature at the refrigerant-to-water condenser. Since controlling the exit water temperature from the refrigerant-to-water condenser is the goal of this control and by definition is the first order effect, K_{conT} is set at -10 for these graphs. The higher the K_{amb} and K_{conT} values, the higher the control reaction to changes in temperature. In the values above, K_{conT} is 16.66 times more sensitive to its temperature changes than K_{amb} . If the system has problems maintaining accurate exit water temperatures from the refrigerant-to-water condenser, K_{conT} should be increased. If K_{conT} is too high, the control will be too sensitive, causing rapid oscillations in fan speed. If K_{conT} is too low, the control will be too insensitive, causing problems maintaining accurate exit water temperatures from the refrigerant-to-water condenser. Kw values from -10 to -20 are usually acceptable.

[0060] The exit water temperature at sensor 275 should run within 2 degrees of the $T_{conT SP}$ depending upon the size of the refrigerant-to-water condenser. If the exit water temperature at sensor 275 runs to the low side, increase $T_{conT SP}$. If the exit water temperature at sensor 275 runs to the high side, decrease $T_{conT SP}$.

[0061] Referring now to FIG. 5A, a graph is shown of ambient temperature at the refrigerant-to-air condenser vs. refrigerant-to-air condenser fan speed for maintaining controlled exit water temperature from the refrigerant-to-water condenser by controller 208 in FIG. 2A and 308 in FIG. 3A. This graph is for a condensing pressure set point of 253 psi and an operational ambient temperature range from 60 to 120° F. As the ambient temperature moves from 60 to 120° F., the fan speed control will change from zero fan speed to 100% fan speed with a defined constant condensing pressure of 253 psi.

[0062] Referring now to FIG. 5B, a graph is shown of exit water temperature from the refrigerant-to-water condenser vs. condensing for maintaining controlled exit water temperature from the refrigerant-to-water condenser. This graph is for the mid point condensing pressure of 253 psi and a condensing pressure range of 6 psi centered about the 253 psi set point. These pressures are for R-22 and must be representative of the refrigerant being used by the system. As the condensing pressure moves from 250 to 256 psi, the fan speed control will change from zero fan speed to 100% fan speed at a constant 90 degree F. ambient temperature at the refrigerant-to-air condenser.

[0063] The control formula for these two graphs can be represented by the following mathematical formula:

$$K_{con} = \frac{[25 + (T_{ambMP} - T_{amb})K_{amb}] + [25 + (P_{conSP} - P_{act})2.5]}{\% \text{ refrigerant-to-air condenser fan speed}}$$

Where:

[0064] T_{amb} equals the ambient air temperature at the refrigerant-to-air condenser.

[0065] T_{ambMP} equals the mid point of expected ambient air temperatures at the refrigerant-to-air condenser.

[0066] P_{act} equals the actual condensing pressure at the refrigerant-to-water condenser and is selected based on the refrigerant used and the desired exit temperature of the refrigerant-to-water condenser. In this case the pressure is measured at the accumulator.

[0067] P_{conSP} equals condensing pressure set point desired from the refrigerant-to-water condenser.

[0068] K_{amb} equals a constant that sets the control sensitivity to changes in ambient temperature at the refrigerant-to-air condenser. The ambient air temperature at the refrigerant-to-air(condenser has a second order effect on the actual exit water temperature from the refrigerant-to-water condenser and K_{amb} is set at -1.66 , a relatively insensitive number.

[0069] K_{con} equals a constant that sets the control sensitivity to changes in condensing pressure at the refrigerant-to-water condenser and thereby the exit water temperature from the refrigerant-to-water condenser. Since controlling the exit water temperature from the refrigerant-to-water condenser is the goal of this control and by definition K_{con} is the first order effect, K_{con} is set at -10 for these graphs. The higher the K_{amb} and K_{con} values, the higher the control reaction to changes in temperature and pressure, respectively. In the values above, K_{con} is 16.66 times more sensitive to its changes than K_{amb} . If the system has problems maintaining accurate exit water temperatures from the refrigerant-to-water condenser, K_{con} should be increased. If K_{con} is too high, the control will be too sensitive, causing rapid oscillations in fan speed. If Kw is too low, the control will be too insensitive, causing problems maintaining accurate exit water temperatures from the refrigerant-to-water condenser. Kw values from -10 to -20 are usually acceptable.

[0070] The exit water temperature at sensor 275 should run within 2 degrees of the P_{conSP} based on the pressure-temperature of the refrigerant being used. If the exit water temperature at sensor 275 runs to the low side, increase P_{conSP} . If the exit water temperature at sensor 275 runs to the high side, decrease P_{conSP} .

[0071] Referring now to FIG. 6A, where Theoretical Outlet Water Temperature, Air Conditioning System Condensing Pressure, Condenser Fan Speed, and Hot Water Requirements at various Operational Conditions are shown for FIG. 2A and 3A. Five Operational Conditions are presented. The No. 1 Condition is for no pool water heating and the Hot Water requirement is zero. The air conditioning system is working normally as shown in FIG. 2B or FIG. 3B and the refrigerant-to-air fan motor 260 is running at 100%. The No. 5 Condition is for full pool water heating and the Hot Water requirement is 100%. Refrigerant condensing is taking place only in the refrigerant-to-water condenser as shown in FIG. 2D and 3D and the refrigerant-to-air fan motor 250 is not running, forcing all condensing to take place at the refrigerant-to-water condenser 234. The No. 2, No. 3, and No. 4 conditions are for

25%, 50% and 75% Hot Water requirements. Fan motor 260 is controlled by controller 208 per control graphs 4A and 4B or 5A and 5B. The ambient air temperature at sensor 276 is 90° F. and has the fan motor 260 running at 50%. Sensor 275 gives the exit temperature of the heated pool water and controller 208 reads this sensor and adjusts fan 260 speed up or down from the 50% level set by ambient sensor 275 per the control formula given previously or control graphs in FIG. 4A and 4B. Since the control formula is 16.66 times more sensitive to the exit water temperature than the ambient air temperature, slight changes in exit water temperature will be corrected by significant changes in refrigerant-to-air condenser fan speed allowing consistent water temperature control over a wide range of operating conditions.

[0072] The same results can be reached by replacing Sensor 275 or 375 readings with condenser pressure sensor 277 or 377 and using control graphs shown in FIG. 5a and 5B and their formula presented previously.

[0073] While the invention has been particularly shown and described with reference to preferred embodiments thereof it is well understood by those skilled in the art that various changes and modifications can be made in the invention without departing from the spirit and scope of the invention as defined by the appended claims.

What is claimed is:

1. A heat pump system for refrigeration or air conditioning, and for heating a fluid comprising:
 - a compressor for supplying high pressure, high temperature gaseous refrigerant to a first condenser for heat exchange with a first condensing fluid and to a second condenser for heat exchange with a second condensing fluid;
 - an expansion valve for receiving high pressure liquid refrigerant from said first and said second condensers;
 - an evaporator for receiving low pressure liquid refrigerant from said expansion valve and supplying low pressure gaseous refrigerant to said compressor;
 - a controller for adjusting the condensing fluid flow rate of said second condenser based on inputs from a first sensor for reading the condensing fluid condition at the first condenser and from a second sensor reading the ambient condition of the second condensing fluid.
2. The system of claim 1 wherein said first condenser and said second condenser are connected in parallel.
3. The system of claim 2 wherein an accumulator is connected between said first and said second condensers for receiving gaseous and or liquid refrigerant, and said accumulator supplies liquid refrigerant to said expansion valve.
4. The system of claim 1 wherein said first condenser and said second condenser are connected in series, and an accumulator is connected between said second condenser and said expansion valve, and a pressure equalization line is connected between said compressor and said accumulator, and said accumulator supplies liquid refrigerant to said expansion valve.
5. The system of claim 1 wherein said first sensor reads the condensing fluid exit temperature of said first condenser, and said second sensor reads the ambient air temperature at said second condenser, and said second condensing fluid is ambient air.
6. The system of claim 5 wherein said controller adjusts the ambient air flow as a percentage of maximum flow in accordance with the following formula: $[25+(T_{ambMP}-T_{amb})K_{amb}]+[25+(T_{wSP}-T_w)K_w]$.

7. The system of claim 6 wherein said ambient air flow rate at said second condenser is adjusted by changing the ambient air fan speed of said second condenser.

8. The system of claim 1 wherein said first sensor reads the condensing pressure of said refrigeration or air conditioning system, and said second sensor reads the ambient air temperature at said second condenser, and said second condensing fluid is ambient air.

9. The system of claim 8 wherein said controller adjusts the ambient air flow rate as a percentage of maximum flow rate in accordance with the following formula: $[25+(T_{ambMP}-T_{amb})K_{amb}]+[25+(P_{conSP}-P_{act})2.5 K_{con}]$.

10. The system of claim 9 wherein said ambient air flow rate at said second condenser is adjusted by changing the ambient air fan speed of said second condenser.

11. The system of claim 1 wherein said first sensor reads the condensing temperature of said refrigeration or air conditioning system, and said second sensor reads the ambient air temperature at said second condenser, and said second condensing fluid is ambient air.

12. The system of claim 11 wherein said controller adjusts the ambient air flow as a percentage of maximum flow in accordance with the following formula: $[25+(T_{ambMP}-T_{amb})K_{amb}]+[25+(T_{conTSP}-T_{conT})K_{conT}]$.

13. The system of claim 12 wherein said ambient air flow rate at said second condenser is adjusted by changing the ambient air fan speed of said second condenser.

14. A heat pump system for refrigeration or air conditioning, and for heating a fluid comprising:

- a compressor for supplying high pressure, high temperature gaseous refrigerant to a first condenser for heat exchange with a first condensing fluid and to a second condenser for heat exchange with a second condensing fluid;
 - said first and second condensers being connected in parallel;
 - an accumulator for receiving high pressure gaseous and/or liquid refrigerant from said first and second condensers;
 - an expansion valve for receiving high pressure liquid refrigerant from said accumulator;
 - an evaporator for receiving low pressure liquid refrigerant from said expansion valve and supplying low pressure gaseous refrigerant to said compressor;
 - a controller for adjusting the condensing fluid flow rate of said second condenser based on inputs from a first sensor for reading the condensing fluid condition at the first condenser and from a second sensor reading the ambient condition of the second condensing fluid.
15. A heat pump system for refrigeration or air conditioning, and heating a fluid comprising:
- a compressor supplying high pressure, high temperature gaseous refrigerant to a first condenser for heat exchange with a first condensing fluid;
 - said first condenser supplying gaseous and/or liquid refrigerant to a second condenser for heat exchange with a second condenser fluid;
 - an accumulator for receiving high pressure liquid refrigerant from said second condenser;
 - a pressure equalization line between said compressor and said accumulator;
 - an expansion valve for receiving high pressure liquid refrigerant from said accumulator;

an evaporator for receiving low pressure liquid refrigerant from said expansion valve and supplying low pressure gaseous refrigerant to said compressor;

a controller for adjusting the condensing fluid flow rate of said second condenser based on inputs from a first sensor for reading the condensing fluid condition at the first condenser and from a second sensor reading the ambient condition of the second condensing fluid.

16. The system of claim **1** where said first fluid is selected from but not limited to water, milk, beer, oil, or air, and said second fluid is selected from but not limited to air, water, oil, or a water antifreeze mix.

17. The system of claim **14** where said first fluid is selected from but not limited to water, milk, beer, oil, or air, and said second fluid is selected from but not limited to air, water, oil, or a water antifreeze mix.

* * * * *