



(51) International Patent Classification:
H04W 36/32 (2009.01)

(21) International Application Number:
PCT/EP2017/082586

(22) International Filing Date:
13 December 2017 (13.12.2017)

(25) Filing Language: English

(26) Publication Language: English

(30) Priority Data:
17155118.7 08 February 2017 (08.02.2017) EP

(71) Applicant: **BRITISH TELECOMMUNICATIONS PUBLIC LIMITED COMPANY** [GB/GB]; 81 Newgate Street, London EC1A 7AJ (GB).

(72) Inventors: **MEHRAN, Farhad**; Ground Floor, Faraday Building 1 Knightrider Street, London EC4V 5BT (GB). **MACKENZIE, Richard**; Ground Floor, Faraday Building 1 Knightrider Street, London EC4V 5BT (GB). **TUK-MANOV, Anvar**; Ground Floor, Faraday Building 1 Knightrider Street, London EC4V 5BT (GB). **FITCH, Michael**; Ground Floor, Faraday Building 1 Knightrider Street, London EC4V 5BT (GB). **BRIGGS, Keith**;

Ground Floor, Faraday Building 1 Knightrider Street, London EC4V 5BT (GB).

(74) Agent: **BRITISH TELECOMMUNICATIONS PUBLIC LIMITED COMPANY, INTELLECTUAL PROPERTY DEPARTMENT**; Ground Floor, Faraday Building 1 Knightrider Street, London EC4V 5BT (GB).

(81) Designated States (unless otherwise indicated, for every kind of national protection available): AE, AG, AL, AM, AO, AT, AU, AZ, BA, BB, BG, BH, BN, BR, BW, BY, BZ, CA, CH, CL, CN, CO, CR, CU, CZ, DE, DJ, DK, DM, DO, DZ, EC, EE, EG, ES, FI, GB, GD, GE, GH, GM, GT, HN, HR, HU, ID, IL, IN, IR, IS, JO, JP, KE, KG, KH, KN, KP, KR, KW, KZ, LA, LC, LK, LR, LS, LU, LY, MA, MD, ME, MG, MK, MN, MW, MX, MY, MZ, NA, NG, NI, NO, NZ, OM, PA, PE, PG, PH, PL, PT, QA, RO, RS, RU, RW, SA, SC, SD, SE, SG, SK, SL, SM, ST, SV, SY, TH, TJ, TM, TN, TR, TT, TZ, UA, UG, US, UZ, VC, VN, ZA, ZM, ZW.

(84) Designated States (unless otherwise indicated, for every kind of regional protection available): ARIPO (BW, GH, GM, KE, LR, LS, MW, MZ, NA, RW, SD, SL, ST, SZ, TZ, UG, ZM, ZW), Eurasian (AM, AZ, BY, KG, KZ, RU, TJ, TM), European (AL, AT, BE, BG, CH, CY, CZ, DE, DK, EE, ES, FI, FR, GB, GR, HR, HU, IE, IS, IT, LT, LU, LV, MC, MK, MT, NL, NO, PL, PT, RO, RS, SE, SI, SK, SM,

(54) Title: CELLULAR TELECOMMUNICATIONS NETWORK

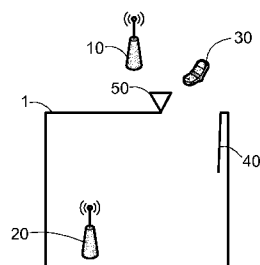

(57) Abstract: This invention relates to a method of operating a cellular telecommunications network, and to a first base station and a UE for implementing the method, the method comprising the steps of: receiving data from an external sensor indicating a first change in a propagation environment between the UE and the base station; and, in response, reconfiguring a connectivity property for the UE.

Figure 1

TR), OAPI (BF, BJ, CF, CG, CI, CM, GA, GN, GQ, GW,
KM, ML, MR, NE, SN, TD, TG).

Published:

— *with international search report (Art. 21(3))*

CELLULAR TELECOMMUNICATIONS NETWORK

Field of the Invention

The present invention relates to a cellular telecommunications network.

5

Background to the Invention

A cellular telecommunications network includes a plurality of base stations which each transmit wireless signals about a coverage area (typically called a “cell”) to one or more User Equipment (UE). The base stations are also connected to a core network to interconnect the UE with the Internet and core network nodes (such as the Operations Support System (OSS)). In conventional cellular networks, this “backhaul” connection between the base station and the core network is typically via an Ethernet or optical fibre link, but in modern cellular networks this may be in part via a Digital Subscriber Line (DSL) connection (for example, if the base station is a “Home evolved Node B” (HeNB), also known as a small cell).

10
15

As each base station has a limited coverage area and UEs are normally mobile, cellular networking protocols have a defined process for UEs to disconnect from one base station and connect to another base station with seamless connectivity. This process is known as a “handover”. A general overview of the handover process will now be described, which is divided into three phases – preparation, execution and completion. The UE is connected to a first base station of a plurality of base stations. The first base station is therefore the UE’s “serving” base station, and the UE is configured to perform measurements of various parameters of its serving base stations and of other base stations of the plurality of base stations. In the preparation phase, the serving base station provides one or more thresholds to the UE for the measurements. If the UE’s measurements satisfy one or more of these thresholds, then a measurement report is sent from the UE to the serving base station, which triggers the handover of the UE to another base station. The serving base station determines which other base station should become the next serving base station for the UE based on the UE’s measurement report. The serving base station and this target base station agree for the handover to take place. In the next phase, execution, the serving base station informs the UE that it should handover to the target base station. The UE will then connect to the target base station. In the completion phase, all routing of packets for the UE is changed to the target base station. The handover is then complete.

20

25

30

35

Conventional cellular networks have coverage areas which may span several squared kilometres. These are now often referred to as macrocells. In recent years, small cells (such as femtocells, metrocells, picocells and microcells) have also been deployed to increase capacity in the network. Most cellular networking protocols currently use frequency bands having a maximum frequency at or less than 3GHz, which can offer large coverage areas but have limited capacity.

To increase capacity to accommodate growing demands for cellular data services, it is expected that future cellular networking protocols will additionally operate above 3GHz (and often above 6GHz). However, any cellular networking protocol using such relatively high-frequencies will be presented with technical problems. For example, the propagation distance of these relatively high-frequency transmissions will be relatively less than conventional cellular networks. In particular, the propagation distance will be very poor through solid materials, such that these relatively high-frequency transmissions are unlikely to penetrate through buildings. To address this problem, it is expected that network operators will deploy base stations using these relatively high-frequencies at a much higher density (per unit area) compared to base station deployment in conventional cellular networks.

Nonetheless, there is a further technical problem, which will now be described. As the coverage areas of these relatively high-frequency base stations have propagation distances which attenuate so rapidly (in air and especially through materials) compared to that of conventional base stations, the relatively high-frequency base stations have very little time to coordinate a handover. In current cellular networks, there is usually sufficient time for the UEs to complete the three phases of the handover before the UE moves out of the serving base station's coverage area. This is because the received signal power at the UE degrades at such a low rate that the handover may be triggered and complete before the UE moves to a position where there is no service from the serving base station at all. In relatively high-frequency base station coverage areas where the degradation of received signal power at the cell edge may be relatively high, it may not be possible for the UE, serving base station and target base station to coordinate such a handover before the UE moves out of range of the serving base station. In such a scenario, the Quality of Service (QoS) for the UE will drop significantly.

It is therefore desirable to alleviate some or all of the above problems.

Summary of the Invention

5 According to a first aspect of the invention, there is provided a method of operating a cellular telecommunications network, the network including a first base station and a User Equipment, UE, the method comprising the steps of: receiving data from an external sensor indicating a first change in a propagation environment between the UE and the base station; and, in response, reconfiguring a connectivity property for the UE.

10 Embodiments of the present invention allow cellular networks to react to data from an external sensor indicating (e.g. detecting or predicting) that the propagation environment between the UE and the base station is changing. The base station may respond to this data by reconfiguring a connectivity property for the UE in order to mitigate any negative impact on QoS for the UE. For example, if the sensor data indicates that the coverage area of the serving base station will soon not cover the UE (e.g. because the user is
15 shutting a door or is about to enter a location not covered by the serving base station), the serving base station may receive data indicating this change from an external sensor (e.g. a door or proximity sensor) and initiate a handover to a more suitable base station.

20 The step of reconfiguring the connectivity property for the UE may include adjusting the first base station's configuration. This may be, for example, adjusting the transmission power of the first base station or, if the base station includes a steerable antenna, this may include adjusting a steering angle of the steerable antenna. Thus, the step of reconfiguring a connectivity parameter may be by adjusting the serving base station's
25 settings, such as its transmission power, the antenna steering angle or its identifier.

The step of reconfiguring the connectivity property for the UE may include instructing a handover of the UE to a second base station, and may further include adjusting the second base station's configuration. The second base station may include a steerable
30 antenna, and the step of adjusting the second base station's configuration may include adjusting a steering angle of the steerable antenna.

The first base station may include a database including an association between the data from the external sensor indicating the first change in propagation environment and a
35 plurality of possible reconfigurations responsive to the first change in propagation

environment, and the method may further include the steps of: determining, from the database, a first reconfiguration of the plurality of possible reconfigurations associated with the first change in propagation environment; and reconfiguring the connectivity property for the UE according to the determined first reconfiguration. In this manner, the first base station is able to record many possible reconfigurations (e.g. to handover to one of several neighbouring base stations) and trial each possible reconfiguration in response to received data indicating a change in the propagation environment. The method may further comprise the steps of receiving success data indicating whether the first reconfiguration was successful; receiving further data from the external sensor indicating the first change in propagation environment; determining, from the database, a second reconfiguration of the plurality of possible reconfigurations associated with the first change in propagation environment based on the received success data; and reconfiguring the connectivity property for the UE according to the determined second reconfiguration. In this manner, the network may learn from previous responsive reconfigurations and make more informed decisions in response to receiving data indicating the same change in the propagation environment.

According to a second aspect of the invention, there is provided a computer program comprising instructions which, when the program is executed by a computer, cause the computer to carry out the method of the first aspect of the invention. The computer program may be stored on a computer-readable data carrier.

According to a third aspect of the invention, there is provided a base station for a cellular telecommunications network, the cellular telecommunications network including a User Equipment, UE, the base station comprising: a transceiver adapted to communicate with the UE and to receive data from an external sensor indicating a first change in a propagation environment between the UE and the transceiver; and a processor adapted to reconfigure a connectivity property for the UE in response to receiving the data.

The processor may be adapted to reconfigure the connectivity parameter by instructing a handover to a second base station or by adjusting the base station's or second base station's configuration.

The step of adjusting the base station's or second base station's configuration may include adjusting a steering angle of an antenna.

The base station may further comprise a database including an association between the data from the external sensor indicating the first change in propagation environment and a plurality of possible reconfigurations responsive to the first change in propagation environment, and the processor is further adapted to: determine, from the database, a first reconfiguration of the plurality of possible reconfigurations associated with the first change in propagation environment; and to reconfigure the connectivity property for the UE according to the determined first reconfiguration.

The transceiver may be further adapted to receive success data indicating whether the first reconfiguration was successful and to receive further data from the external sensor indicating the first change in propagation environment; and the processor may be further adapted to determine, from the database, a second reconfiguration of the plurality of possible reconfigurations associated with the first change in propagation environment based on the received success data; and to reconfigure the connectivity property for the UE according to the determined second reconfiguration.

According to a fourth aspect of the invention, there is provided a node for a cellular telecommunications network, the cellular telecommunications network including a first base station and a User Equipment, UE, the node comprising a transceiver adapted to receive data from an external sensor indicating a first change in a propagation environment between the UE and the first base station; and a processor adapted to reconfigure a connectivity property for the UE in response to receiving the data.

Brief Description of the Figures

In order that the present invention may be better understood, embodiments thereof will now be described, by way of example only, with reference to the accompanying drawings in which:

Figure 1 is a schematic diagram illustrating a first embodiment of a cellular telecommunications network of the present invention;

Figure 2 is a schematic diagram of a base station of the network of Figure 1;

Figure 3 is a schematic diagram of a sensor of the network of Figure 1;

Figure 4a is a schematic diagram of the network of Figure 1 in a first state;

Figure 4b is a schematic diagram of the network of Figure 1 in a second state;

Figure 5 is a flow diagram illustrating a first embodiment of a method of the present invention;

Figure 6a is a schematic diagram of a second embodiment of a cellular telecommunications network of the present invention in a first state;

5 Figure 6b is a schematic diagram of the network of Figure 6a in a second state;

Figure 7 is a flow diagram illustrating a second embodiment of a method of the present invention;

Figure 8a is a schematic diagram of a third embodiment of a cellular telecommunications network of the present invention in a first state;

10 Figure 8b is a schematic diagram of the network of Figure 8a in a second state;

Figure 9 is a flow diagram illustrating a third embodiment of a method of the present invention;

Figure 10a is a schematic diagram of a fourth embodiment of a cellular telecommunications network in a first state;

15 Figure 10b is a schematic diagram of the network of Figure 10a in a second state;

Figure 10c is a schematic diagram of the network 10a in a third state;

Figure 11 is a schematic diagram of a remote transceiver of the network of Figure 10a; and

Figure 12 is a flow diagram illustrating a fourth embodiment of a method.

20

Detailed Description of Embodiments

A first embodiment of the present invention will now be described with reference to Figures 1 to 3. Figure 1 illustrates an enclosed area 1 and a first and second base station 10, 20. The first base station 10 is outside the enclosed area and serves a User Equipment (UE) 30. The second base station 20 is inside the enclosed area. The enclosed area 1 includes a door 40, which is open in Figure 1, and a door status sensor 50.

25

The first base station 10 is shown in more detail in Figure 2. The first base station 10 includes a first transceiver 11, a processor 13, memory 15, a second transceiver 17, and a third transceiver 18, all connected via bus 19. In this embodiment, the first transceiver 11 is an antenna configured for wireless communication via a cellular telecommunications protocol using a frequency band covering (at least in part) frequencies above 3GHz. The second transceiver 17 is a backhaul interface (in this example, an optical fibre connection) for connecting the first base station 10 to the core

35

network and the Internet. The third transceiver 18 is configured for wireless communication with the door status sensor 50.

5 In this embodiment, the first and second base stations 10, 20 are substantially the same and comprise the same components.

10 The door status sensor 50 is shown in more detail in Figure 3. The sensor 50 includes a transceiver 51, a processor 53, a motion sensor 55, and memory 57, all connected via bus 59. The transceiver 51 is configured for wireless communications with the first and second base stations 10, 20. The motion sensor 55 is positioned on the door 40 and produces an electrical signal which is a function of the door opening angle, θ . This signal is recorded in memory 57 together with a timestamp. It is therefore possible to determine if the door 40 is fully closed or fully open based on the maximum and minimum values of the door opening angle. Furthermore, it is also possible to determine whether the door is opening or closing based on whether the door opening angle is increasing or decreasing. The door status sensor 50 is also configured to transmit the value of the door opening angle to the first and second base station 10, 20. In this embodiment, this message is transmitted in response to several triggers (e.g. the rate of change of the door opening angle exceeding a threshold, the door opening angle being at a maximum indicating the door being fully open, and the door opening angle being at a minimum indicating the door being fully closed).

25 A first embodiment of a method of the invention will now be described with reference to Figures 4a, 4b and 5. The scenario depicted in Figure 4a is identical to that of Figure 1. It is also noted that the UE 30 is in position P_A and is connected to the first base station 10. The door 40 is open and the door status sensor 50 sends a signal to the first and second base stations 10, 20 indicating that the door opening angle is indicative of the door being fully open. The first and second base stations 10, 20 receive these signals via their first transceivers and record this data in memory.

30 Figure 4b illustrates the same cellular communications network but at a later time. The UE 40 has moved from position P_A , outside the enclosed area 1, to position P_B , inside the enclosed area 1. The user is also shutting the door such that the door opening angle is decreasing. Accordingly, the door status sensor 50 detects that the rate of change of

the door opening angle is greater than a threshold and transmits signals to the first and second base stations 10, 20 indicating that the door is closing.

5 In this embodiment, the first and second base stations 10, 20 use relatively high-frequency transmissions which are unable to penetrate the building materials of the enclosed area 1. Accordingly, as the user enters the enclosed area 1 and shuts the door behind them (i.e. as the UE 30 moves from position P_A to position P_B), the following process (as illustrated in Figure 5) takes place.

10 In a first step S1.1, the first base station 10 receives the signal from the door status sensor 50 indicating that the door is closing. In response, in step S1.2, the first base station 10 sends a message to the second base station 20 requesting the handover of the UE 30 to the second base station 20, and the second base station 20 responds by sending a handover acceptance message to the first base station 10. In this
15 embodiment, these messages are sent using the first transceivers. In step S1.3, the first base station sends an instruction message to the UE 30 instructing it to connect to the second base station 20. These messages are sent and received before the door 40 is shut such that the UE 30 may be instructed to handover to the second base station 20 whilst it may still receive the relatively high-frequency transmissions from the first base
20 station 10. In step S1.4, the UE 30 connects to the second base station 20 and all traffic for the UE 30 is redirected via the second base station 20.

Thus, by implementing this embodiment of the method of the present invention, the cellular network is able to ensure that the UE 30 receives seamless connectivity despite
25 the UE 30 moving to a position where there is no service from its serving base station and the rate of change of received power of signals from the serving base station at the edge of its coverage area is so high that there is not enough time to perform a conventional handover. This problem is solved, in this embodiment, by using an external sensor to indicate that the propagation environment is changing which triggers the
30 handover to the second base station 20.

A second embodiment of the invention will now be described with reference to Figure 6a. This embodiment uses the same enclosed area 1, first and second base station 10, 20 and UE 30 as the first embodiment, and the same reference numerals have been
35 used. This embodiment further includes a window 60 and a window status sensor 70,

which operate in a similar manner to the door 40 and door status sensor 50 of the first embodiment (such that the window may move between an open and closed state, and the window sensor 70 is configured to produce a signal indicating that the window is open, closed or that the rate of change of window opening angle indicates that the window is opening or closing).

A second embodiment of the method of the present invention will now be described with reference to Figures 6a, 6b and 7. Figure 6a depicts a first state in which the UE 30 is positioned inside the enclosed area 1 and is connected to the second base station 20. The window 60 is closed and the window status sensor 70 transmits a signal to the first and second base stations 10, 20 indicating the same.

Figure 6b depicts a second state in which the UE 30 is still positioned inside the enclosed area 1 but the window 60 is now open. Figure 7 illustrates the second embodiment of the method of the present invention which is implemented in this scenario. In a first step (step 2.1), the user opens the window 60 and the rate of change of the window opening angle exceeds the threshold such that the window sensor 70 transmits a signal to the first and second base stations 10, 20 indicating that the window 60 is opening.

In a second step (step S2.2), the second base station 20 receives this signal and, in response, initiates a handover of the UE 30 to the first base station 10. This is performed as signals from the first base station 10 would otherwise significantly interfere with any transmission between the second base station 20 and the UE 30 if the UE 30 continued to be served by the second base station 20. Accordingly, the second base station 20 sends a message to the first base station 10 requesting a handover of the UE 30 (step S2.3), and the first base station responds by sending a message to the first base station 10 accepting the handover (step S2.4). The second base station 20 then sends a message to the UE 30 instructing it to connect to the first base station 10 (step S2.5), and all traffic for the UE 30 is redirected via the first base station 10.

Thus, the second embodiment of the method of the present invention also utilises an external sensor to identify when there is a change in the propagation environment for the UE 30 (despite the UE being static in this example) and, in response, initiates a handover before any reduction in the UE's QoS.

35

A third embodiment of the present invention will now be described with reference to Figure 8a. This embodiment again uses the same enclosed area 1, first and second base station 10, 20 and UE 30 as the first embodiment, and the same reference numerals have been used. In this embodiment, the UE 30 is positioned inside the enclosed area 1 and is connected to the second base station 20. Furthermore, the first base station 10 is positioned outside the enclosed area 1 and has a coverage area 12 depicted in Figure 8a. The door status sensor 50 is again configured to transmit signals to the first and second base stations 10, 20 indicating whether the door 40 is open, closed, or the rate of change of the door opening angle has exceeded a threshold indicating that the door 40 is opening or closing.

A third embodiment of a method of the present invention will now be described with reference to Figures 8a, 8b and 9. Figure 8a depicts a first state in which the UE 30 is positioned inside the enclosed area 1 in position P_A and is served by the second base station 20. The door 40 is open and the first and second base stations 10, 20 receive signals indicating the same.

Figure 8b depicts a second state in which the UE 30 is now positioned outside the enclosed area 1 in position P_B and the door 40 is now closed. Figure 9 illustrates the third embodiment of a method of the present invention which is implemented in this scenario. In a first step (step S3.1), the user moves from position P_A to P_B . The user is also shutting the door such that the door opening angle is decreasing. Accordingly, the door status sensor 50 detects that the rate of change of the door opening angle is greater than a threshold and transmits signals to the first and second base stations 10, 20 indicating that the door is closing.

In step S3.2, the first and second base stations 10, 20 receive and react to this signal. In step S3.3, the second base station 20 sends a message to the first base station 10 which requests a) the handover of the UE 30 to the first base station 10 and b) that the first base station 10 reconfigures its antenna configuration such that its coverage area 12 covers the UE's new position P_B . The first base station 10 responds by sending a handover acceptance message to the second base station 20 and, in step S3.4, by reconfiguring its antenna configuration such that its coverage area 12 includes position P_B . In step S3.5, the second base station 20 sends an instruction message to the UE 30 instructing it to connect to the first base station 10. These messages are sent and

received before the door 40 is shut such that the UE 30 may be instructed to handover to the first base station 10 and the first base station 1 reconfigures its coverage area before the door 40 is closed. In step S3.6, the UE 30 connects to the first base station 10 and all traffic for the UE 30 is redirected via the first base station 10.

5

In a further enhancement to any one of the above embodiments of the present invention, the first and second base stations 10, 20 are configured to compile a database (stored in memory) having the following data values:

1. An event profile;
- 10 2. A possible reconfiguration profile; and
3. A success ratio.

The base stations are configured to store a plurality of different event profiles, wherein each event profile describes a particular sequence of UE and/or sensor based events (e.g. the UE is connected to a particular base station, the sensor detects a particular change, etc.). The base stations are then configured to populate the database with all possible reconfiguration profiles for each event profile, wherein each possible reconfiguration profile describes a particular responsive action the base station may employ in response to that particular event profile (e.g. handover to another base station, reconfigure an antenna configuration). Lastly, the base stations are configured to receive feedback on each reconfiguration profile used in the network and calculate a value of the success ratio of that reconfiguration profile when used in response to that event. An example database is illustrated in Table 1, below:

20

Event Profile	Possible Reconfiguration Profile	Success Ratio
E1 (UE 30 connected to first base station (BS) 10; door sensor 50 indicates that door 40 is closing)	P1 (No reconfiguration)	0
E1 (UE 30 connected to first BS 10; door sensor 50 indicates that door 40 is closing)	P2 (Handover UE 30 to second BS 20; second BS 20 antenna configuration 1)	1
E2 (UE 30 connected to second BS 20; door sensor 50 indicates that door 40 is closing)	P3 (No reconfiguration)	0

E2 (UE 30 connected to second BS 20; door sensor 50 indicates that door 40 is closing)	P3 (Handover UE 30 to first BS 10; first BS 10 antenna configuration 1)	0.2
E2 (UE 30 connected to second BS 20; door sensor 50 indicates that door 40 is closing)	P3 (Handover UE 30 to first BS 10; first BS 10 antenna configuration 2)	1
E3 (UE 30 connected to second BS 20; window sensor 70 indicates that window 60 is opening)	P4 (No reconfiguration)	0.1
E3 (UE 30 connected to second BS 20; window sensor 70 indicates that window 60 is opening)	P5 (Handover UE 30 to first BS 10, first BS 10 antenna configuration 1)	1
E3 (UE 30 connected to second BS 20; window sensor 70 indicates that window 60 is opening)	P6 (Handover UE 30 to first BS 10, first BS 10 antenna configuration 2)	1

Table 1: Table illustrating event profiles, reconfiguration profiles and success ratio

The first and second base stations 10, 20 are therefore able to build an association between each event profile and each reconfiguration profile. This database may increase in size rapidly as each possible event profile (which may comprise a sequence of sub-events each associated with a particular sensor) may be associated with each possible reconfiguration profile (which may comprise each neighbouring base station and each possible configuration of that base station, including antenna configuration, power configuration, etc.). The first and second base stations 10, 20 may then trial each possible reconfiguration profile whenever a particular event occurs, and receive feedback on whether that was a success or not (e.g. by the target base station informing it of whether the UE successfully connected and received threshold QoS values) to calculate a success ratio value. Once these reconfiguration profiles have been trialled several times, the database becomes a useful resource for the first and second base stations 10, 20 to make informed decisions on a suitable response to a particular event profile. This improves the likelihood of subsequent responsive reconfigurations being successful.

In the above embodiments, the reconfiguration (e.g. handover) is triggered by a sensor event and is completed before the propagation environment changes. For example, in

the first embodiment, the sensor detects that the door is closing, and the handover is complete before the door is closed. However, the skilled person will understand that it is not essential for the invention to be limited to scenarios in which the reconfiguration completes before the change in the propagation environment. For example, the base stations may be configured to transmit these signals at a relatively low frequency that may span a much larger coverage area and with improved propagation properties through solid materials.

The skilled person will also understand that, in the enhanced embodiment in which the base station improves the likelihood of a reconfiguration being a success based on prior reconfigurations, the base station receives data regarding the success of prior reconfigurations to calculate the success ratio value. This data may be received from another base station, the UE, or another network entity measuring the performance of the UE.

The skilled person will also understand that it is not essential for all steps of the handover process to take place in the present invention. That is, the preparation phase (in which the base station provides the UE with thresholds for its measurements, and the UE sends a message to the base station when the measurements satisfy such thresholds) are not necessary as the trigger for the reconfiguration is receipt of data from the external sensor. Such a handover may be known as a "blind" handover.

The skilled person will also understand that the present invention is not limited to the reconfiguration of a connectivity parameter for a single UE. That is, the method of the present invention may comprise the step of a configuration parameter between a base station and a plurality of UEs being reconfigured in response to data from an external sensor. For example, in the example of the second embodiment in which a window opens and signals from the first base station would significantly interfere with the connection between the second base station and its UEs, the second base station may receive the signal from the window sensor indicating that the window is opening and, in response, initiate the handover of several of its connected UEs to the first base station. There may also be an intermediate step in which the second base station instructs the preparation of measurement reports from its UEs to determine which should be transferred to the first base station.

Furthermore, the method of the present invention may also include a step of determining which UE or group of UEs should be party to the reconfiguration following receipt of the external sensor data based on some logic, such as the determined location of one or more UEs.

5

A fourth embodiment will now be described with reference to Figure 10a, in which the same reference numerals have been used for similar components. Figure 10a illustrates an enclosed area 1 and a first and second base station 10, 20. The first base station 10 is outside the enclosed area 1 and the second base station 20 is inside the enclosed area 1. The enclosed area 1 includes a door 40, and a door status sensor 50. As in the previous embodiments, the door sensor 50 is configured to determine the opening angle of door 40 and is configured to transmit a value of the door opening angle in response to several triggers (e.g. the rate of change of the door opening angle exceeding a threshold, the door opening angle being at a maximum indicating the door being fully open, and the door opening angle being at a minimum indicating the door being fully closed).

10

15

Figure 10a also illustrates a remote transceiver 80. The remote transceiver 80 is shown in more detail in Figure 11, and includes a first transceiver 81 (configured to communicate with a UE via an antenna), a processor 83, memory 85, and a second transceiver 87, all connected via bus 89. The remote transceiver 80 is configured to receive signals from a base station (such as the first or second base station 10, 20) via the second transceiver 87, and transmit these signals via the first transceiver 81. In this embodiment, the remote transceiver 80 is connected to the first base station 10 via their respective second transceivers 17, 87 (such that the remote transceiver 80 may therefore be considered a remote radio head for the first base station 10), although the remote transceiver 80 is only configured to repeat all signals of the first base station 10 (rather than having distinct transmissions like regular remote radio heads).

20

25

A method will now be described with reference to Figures 10a to 10c and Figure 12. In a first state as shown in Figure 10a, the UE 30 is positioned outside the enclosed area (in position P_A) and is connected to the first base station 10. The UE then moves into the enclosed area 1 to position P_B and the user closes the door 40 (as shown in Figure 10b), such that the rate of change of the door opening angle exceeds a threshold and the door status sensor 50 produces a signal indicating that the door is closing. In this

30

embodiment, this signal is transmitted to the first and second base stations 10, 20 (step S4.1)

5 The first base station 10 receives this signal (step S4.2) and reacts to it by sending an instruction signal to the remote transceiver 80 (step S4.3). This instruction signal is sent via the second transceiver 17 of the first base station 10 to the second transceiver 87 of the remote transceiver 80 (this may be via the cellular core network, or may be an alternative dedicated connection). The remote transceiver 80 receives this instruction signal and, in response, is activated (that is, it switches from an unpowered or low-power state, to a fully powered and fully operational state).

10 In step S4.4, the first base station 10 also sends a stream of UE downstream data to the remote transceiver 80 via their respective second transceivers 17, 87. In this embodiment, this stream of UE downstream data is the same data that is transmitted by the first transceiver 11 to all UEs served by the first base station 10. As shown in Figure 10b, the remote transceiver 80 is configured to transmit these signals (via its first transceiver 81) about a coverage area 82 that fills the enclosed area 1 (step S4.5). In doing so, the first base station 10 and the remote transceiver 80 are able to react to the sensor data indicating that there is going to be a change in the propagation environment between the UE and the first base station 10 to ensure that the UE receives seamless connectivity. Thus, even once the door 40 closes and the UE 30 is in a position that is no longer directly served by the first base station 10, it still maintains its downstream and upstream connection via the remote transceiver 80.

25 In this embodiment, the UE 30 is encouraged to subsequently hand over to the second base station 20 in the following process. As shown in Figure 10c, the remote transceiver 80 gradually reduces its coverage area 82 (step S4.6), for example, from 100% to 0% of its transmission power over a time period of 10 seconds. In doing so, the UE's 30 connection to the remote transceiver 80 will gradually deteriorate. During this time period, the UE continues to prepare measurement reports of its serving base stations and of other base stations in the network (e.g. the second base station). Eventually, one or more parameters in the measurement report for the first base station will drop below its threshold, thus triggering a handover. The UE 30 will therefore send the measurement reports to the first base station 10 (step S4.7), and the first base station 35 10 will coordinate a handover of the UE 30 to the second base station 20 (step S4.8).

The skilled person will understand that it is not essential for the remote transceiver 80 to be a remote radio head of the first base station 10 and/or have a wired connection to the first base station 10. Instead, the remote transceiver 80 may be a cellular repeater in which the second transceiver 87 is an antenna. In this arrangement (and following the example used above), the second transceiver 87 may be positioned outside the enclosed area 1, receive the cellular signals transmitted by the first base station 10, and repeat these signals by transmitting them from the first transceiver 81 into the enclosed area 1. More generally, the cellular repeater may have a plurality of receiving antennas and a plurality of transmitting antennas, which may all be positioned in distinct locations (such as either side of a wall).

The skilled person will also understand that it is not essential for the remote transceiver and first base station 10 to communicate using the backhaul. That is, the first base station 10 and remote transceiver 80 may communicate using distinct antennae operating with a lower frequency range (e.g. one that may penetrate the wall). Furthermore, the remote transceiver 80 may be activated directly by the external sensor (e.g. by receiving the signal from the external sensor at one of its transceivers, or a further transceiver) with no intervention from a base station.

The above embodiments detail several forms of sensor. However, the skilled person will understand that the invention is not limited to these examples. That is, the benefits of the present invention may be realised by any sensor that is external to the cellular network and that may detect or predict a change in the propagation environment between the base station and the UE. These sensors may be, for example, mechanical, (e.g. piezoelectric), sound, radiofrequency or motion sensors. Furthermore, the primary purpose of the sensor does not have to be for the benefits of the invention. Any device which has a suitable detector for detecting or predicting a change in the propagation environment may be used. For example, a device containing an Intelligent Personal Assistant, IPA, (such as Microsoft © Cortana, or Amazon © Alexa) may be used to detect or predict a change in the propagation environment (for example, if the user instructs the IPA to shut a door or window). Furthermore, it is not essential that the base stations have separate wireless interfaces for communicating with the external sensor. The interface may also be a separate wired interface, or may also be implemented by the first

or second transceiver (e.g. the first transceiver using a different frequency to those used with the UE).

5 In the above embodiments, the base station and UEs are configured for cellular communications above 3GHz, which would be significantly attenuated by solid materials such that they would be unlikely to penetrate into an area enclosed by solid materials. However, the skilled person will understand that the invention is not limited to such frequencies. The present invention is beneficial in any situation in which there are abrupt changes in the serving base station's coverage area. This may be realised by base
10 stations with relatively low-frequency transmissions (such as traditional base stations operating below 3GHz) being unable to penetrate areas enclosed by very high density materials (as such materials would still attenuate these transmissions over a very short distance).

15 Furthermore, the skilled person will understand that any (detected or predicted) change in the propagation environment may be used as the trigger to reconfigure a connectivity parameter for the UE, and the invention is therefore not limited to the examples identified above. The skilled person will also understand that the particular reconfigurations detailed in the above embodiments are merely examples, and any form of reconfiguration
20 may be used. For example, the serving/target base station may use a different transmission power, frequency band or identifier. Furthermore, the serving base station may handover to another base station, or merely to another sector of the same base station.

25 The skilled person will also understand that it is not necessary for the base station to react to the data from the sensor indicating a change in the propagation environment. That is, any network node may be configured to receive data from a sensor indicating a change in a propagation environment between a base station and a UE, and, in response, initiate the above detailed methods (such as, for example, sending an
30 instruction message to the base station to initiate a handover of the UE to another base station). Furthermore, such a network node may also be the UE.

The skilled person will understand that any combination of features is possible within the scope of the invention, as claimed.

35

CLAIMS

1. A method of operating a cellular telecommunications network, the network including a first base station and a User Equipment, UE, the method comprising the steps of:
- 5 receiving data from an external sensor indicating a first change in a propagation environment between the UE and the base station; and, in response, reconfiguring a connectivity property for the UE.
- 10 2. A method as claimed in Claim 1, wherein the step of reconfiguring the connectivity property for the UE includes adjusting the first base station's configuration.
3. A method as claimed in Claim 2, wherein the first base station includes a steerable antenna, and the step of adjusting the first base station's configuration
- 15 includes adjusting a steering angle of the steerable antenna.
4. A method as claimed in Claim 1, wherein the step of reconfiguring the connectivity property for the UE includes instructing a handover of the UE to a second base station.
- 20 5. A method as claimed in Claim 4, wherein the step of reconfiguring the connectivity property for the UE further includes adjusting the second base station's configuration.
- 25 6. A method as claimed in Claim 5, wherein the second base station includes a steerable antenna, and the step of adjusting the second base station's configuration includes adjusting a steering angle of the steerable antenna.
7. A method as claimed in any one of the preceding claims, wherein the first base station includes a database including an association between the data from the
- 30 external sensor indicating the first change in propagation environment and a plurality of possible reconfigurations responsive to the first change in propagation environment, and the method further includes the steps of:
- 35 determining, from the database, a first reconfiguration of the plurality of possible reconfigurations associated with the first change in propagation environment; and

reconfiguring the connectivity property for the UE according to the determined first reconfiguration.

8. A method as claimed in Claim 7, further comprising the steps of:

- 5 receiving success data indicating whether the first reconfiguration was successful;
receiving further data from the external sensor indicating the first change in
propagation environment;
determining, from the database, a second reconfiguration of the plurality of possible
reconfigurations associated with the first change in propagation environment based on
10 the received success data; and
reconfiguring the connectivity property for the UE according to the determined second
reconfiguration.

9. A computer program comprising instructions which, when the program is

- 15 executed by a computer, cause the computer to carry out the method of any one of the
preceding claims.

10. A computer-readable data carrier having stored thereon the computer program
of Claim 9.

20

11. A base station for a cellular telecommunications network, the cellular
telecommunications network including a User Equipment, UE, the base station
comprising:

- 25 a transceiver adapted to communicate with the UE and to receive data from an external
sensor indicating a first change in a propagation environment between the UE and the
transceiver; and
a processor adapted to reconfigure a connectivity property for the UE in response to
receiving the data.

- 30 12. A base station as claimed in Claim 11, wherein the processor is adapted to
reconfigure the connectivity parameter by instructing a handover to a second base
station or by adjusting the base station's or second base station's configuration.

13. A base station as claimed in Claim 12, wherein the step of adjusting the base station's or second base station's configuration includes adjusting a steering angle of an antenna.

5 14. A base station as claimed in any one of Claims 11 to 13, further comprising a database including an association between the data from the external sensor indicating the first change in propagation environment and a plurality of possible reconfigurations responsive to the first change in propagation environment, and the processor is further adapted to:
10 determine, from the database, a first reconfiguration of the plurality of possible reconfigurations associated with the first change in propagation environment; and to reconfigure the connectivity property for the UE according to the determined first reconfiguration.

15 15. A base station as claimed in any one of Claims 11 to 14, wherein the transceiver is further adapted to receive success data indicating whether the first reconfiguration was successful and to receive further data from the external sensor indicating the first change in propagation environment; and the processor is further adapted to determine, from the database, a second reconfiguration of the plurality of
20 possible reconfigurations associated with the first change in propagation environment based on the received success data; and to reconfigure the connectivity property for the UE according to the determined second reconfiguration.

25 16. A node for a cellular telecommunications network, the cellular telecommunications network including a first base station and a User Equipment, UE, the node comprising
a transceiver adapted to receive data from an external sensor indicating a first change in a propagation environment between the UE and the base station; and
a processor adapted to initiate a reconfiguration of a connectivity property for the UE in
30 response to receiving the data.

17. A node as claimed in Claim 16, being the UE.

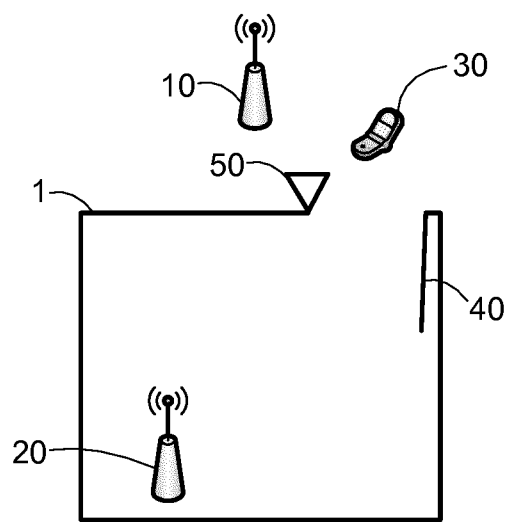

Figure 1

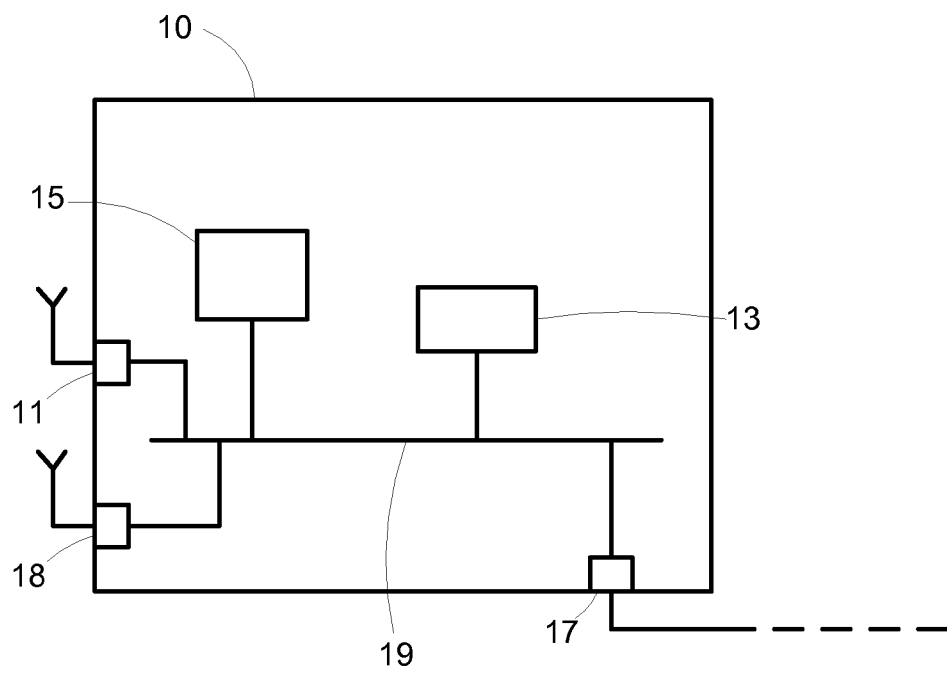

Figure 2

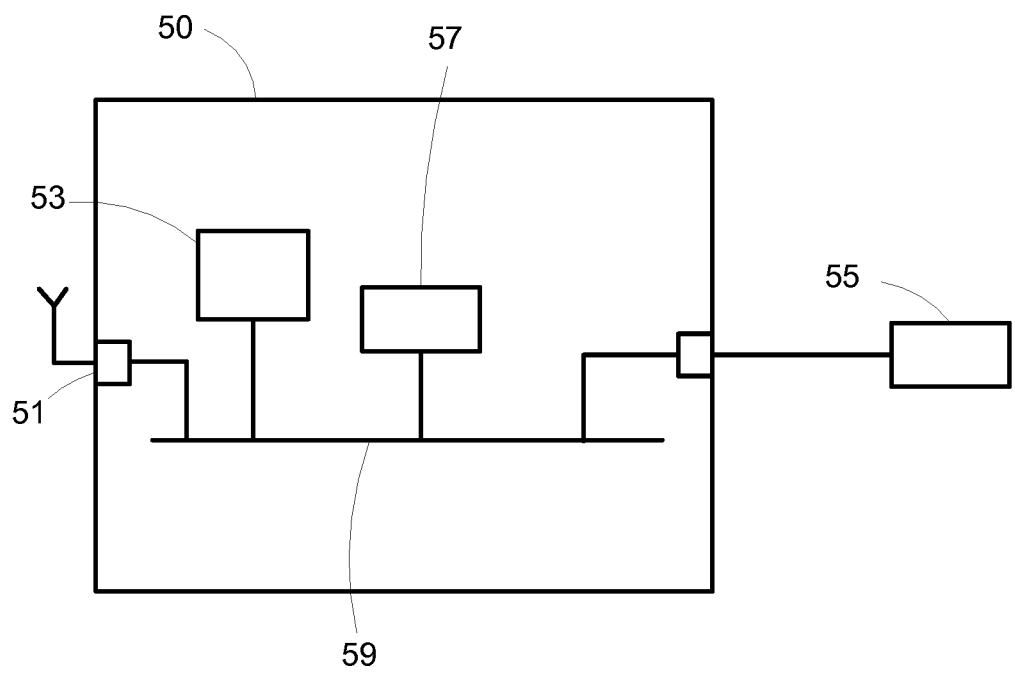

Figure 3

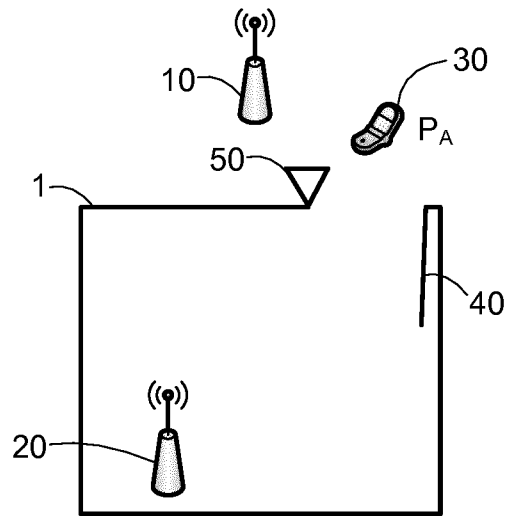

Figure 4a

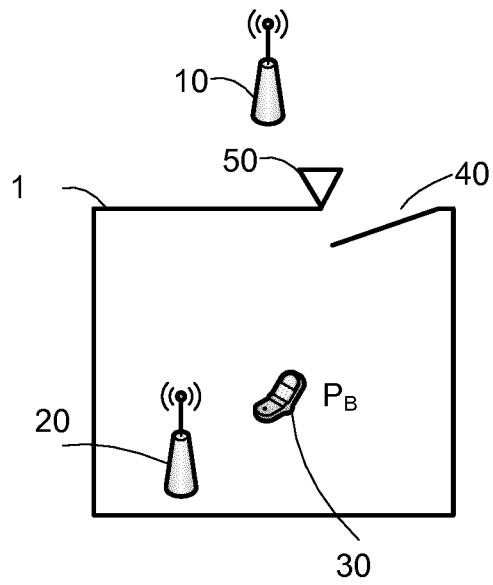

Figure 4b

5/12

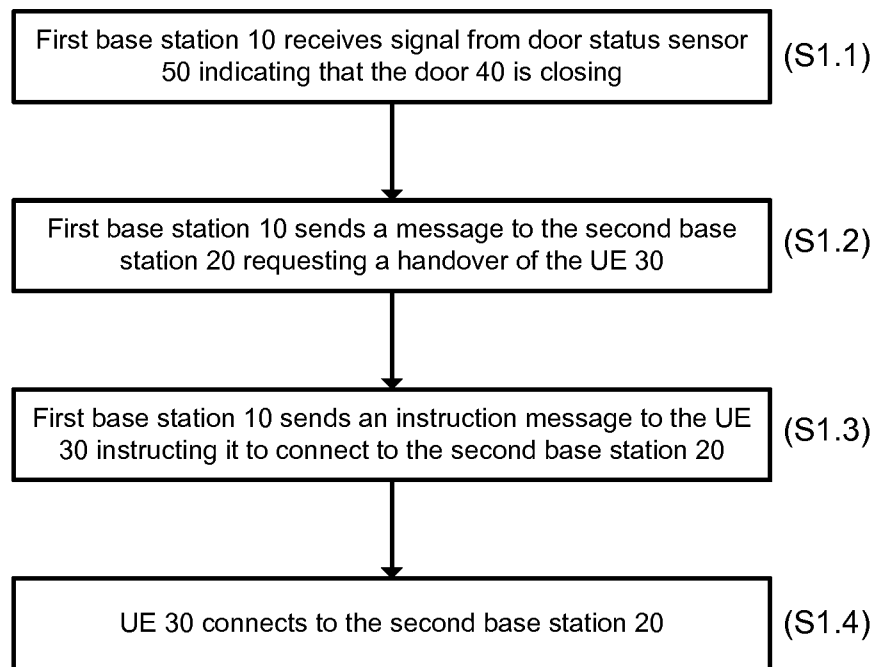

Figure 5

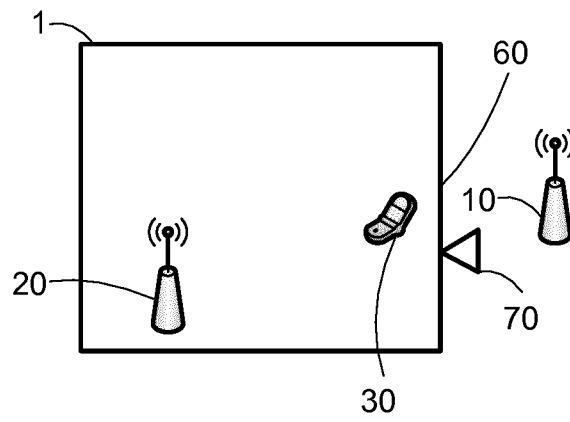

Figure 6a

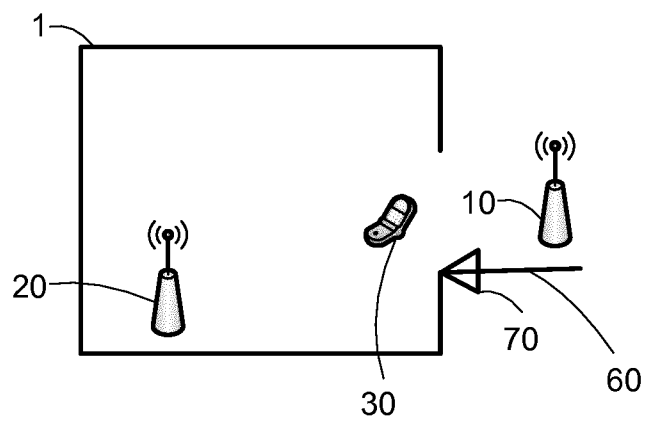

Figure 6b

7/12

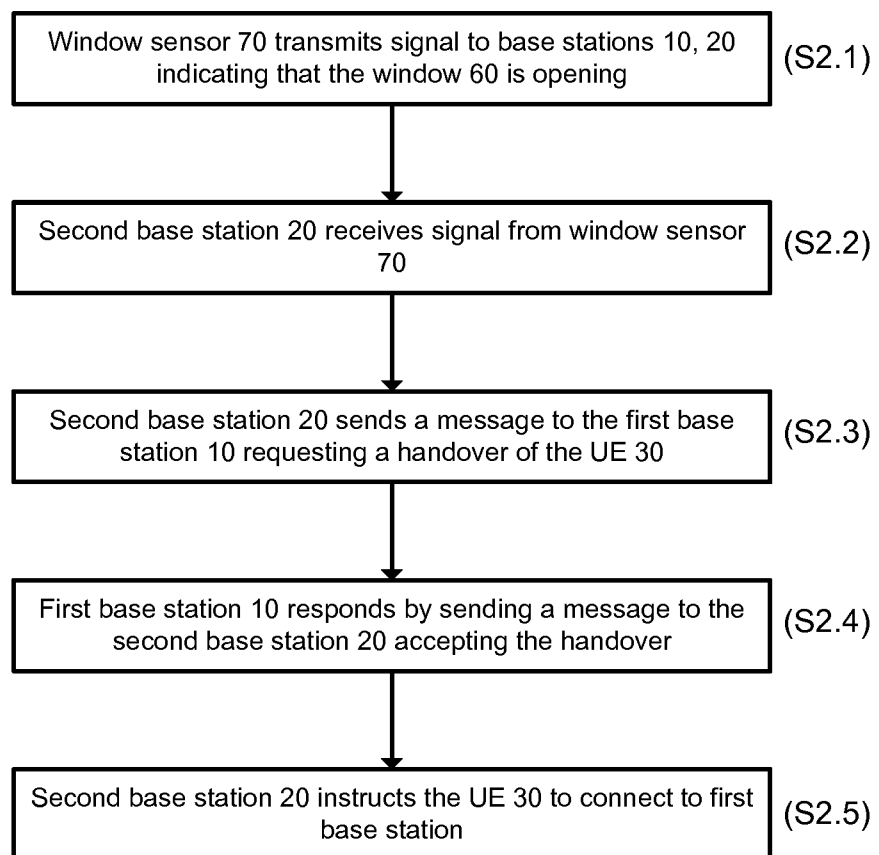

Figure 7

8/12

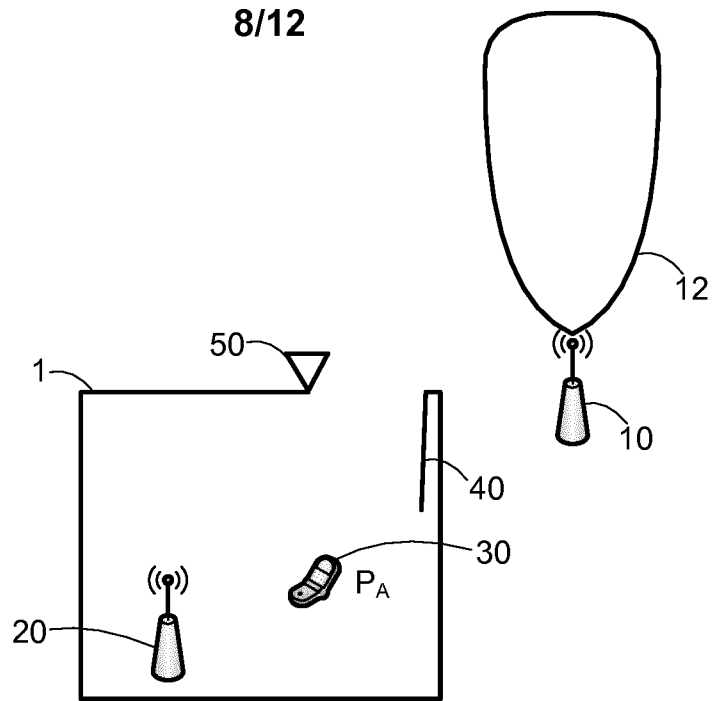

Figure 8a

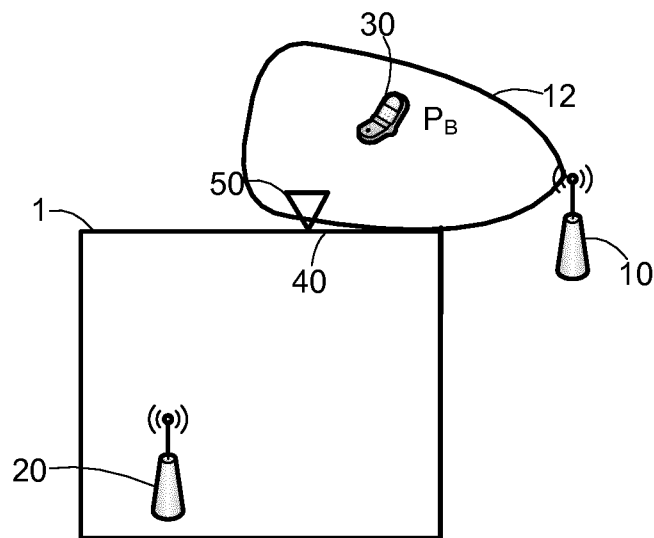

Figure 8b

9/12

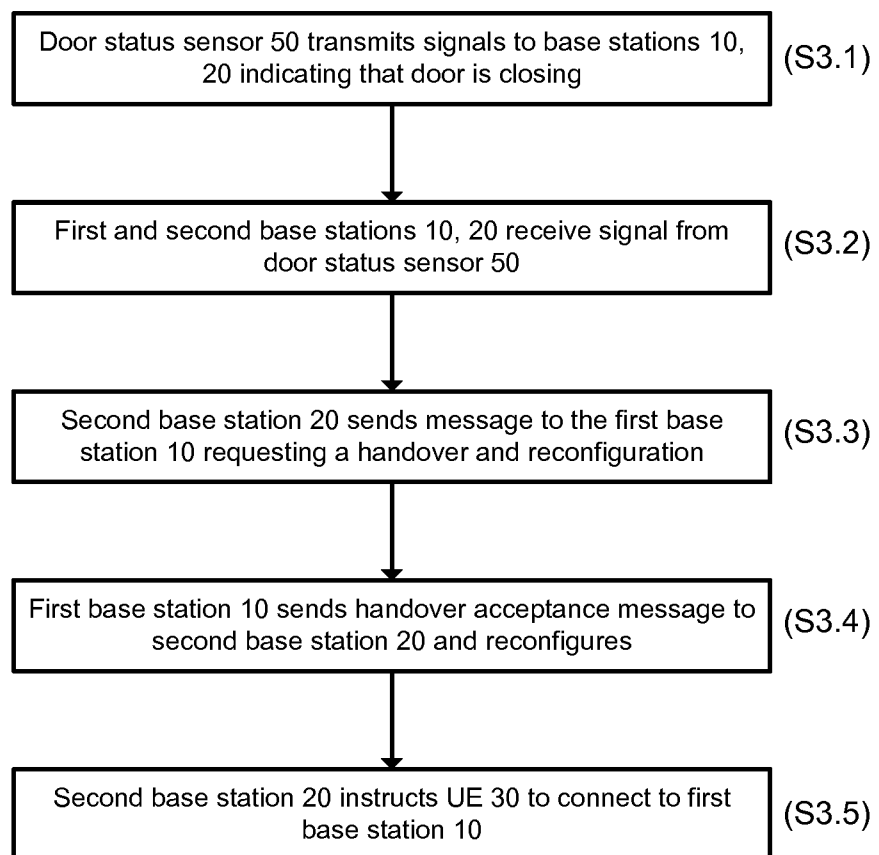

Figure 9

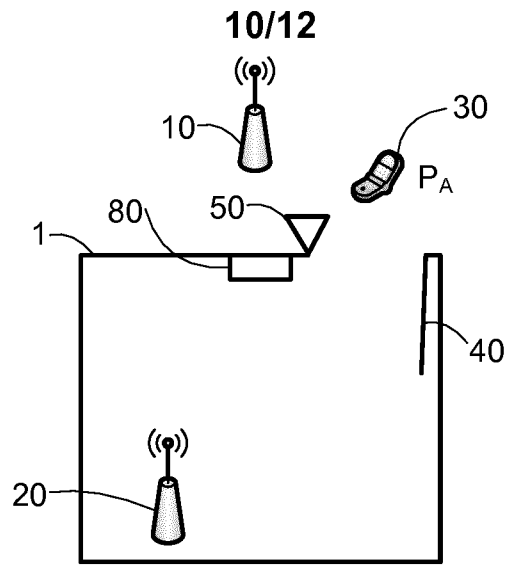

Figure 10a

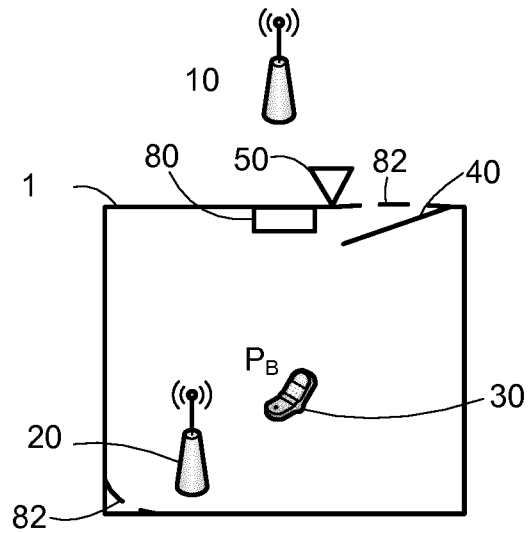

Figure 10b

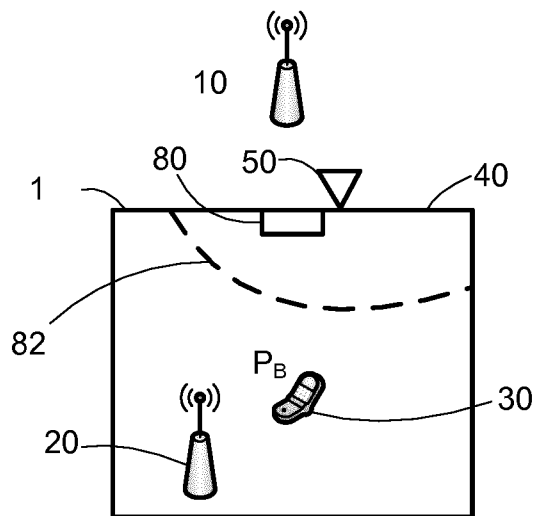

Figure 10c

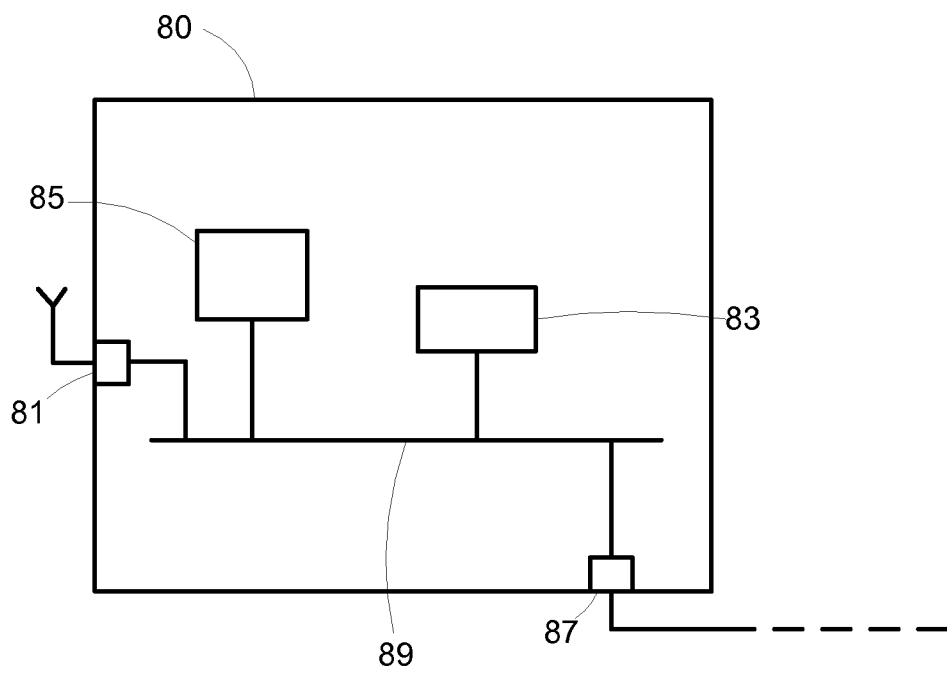

Figure 11

12/12

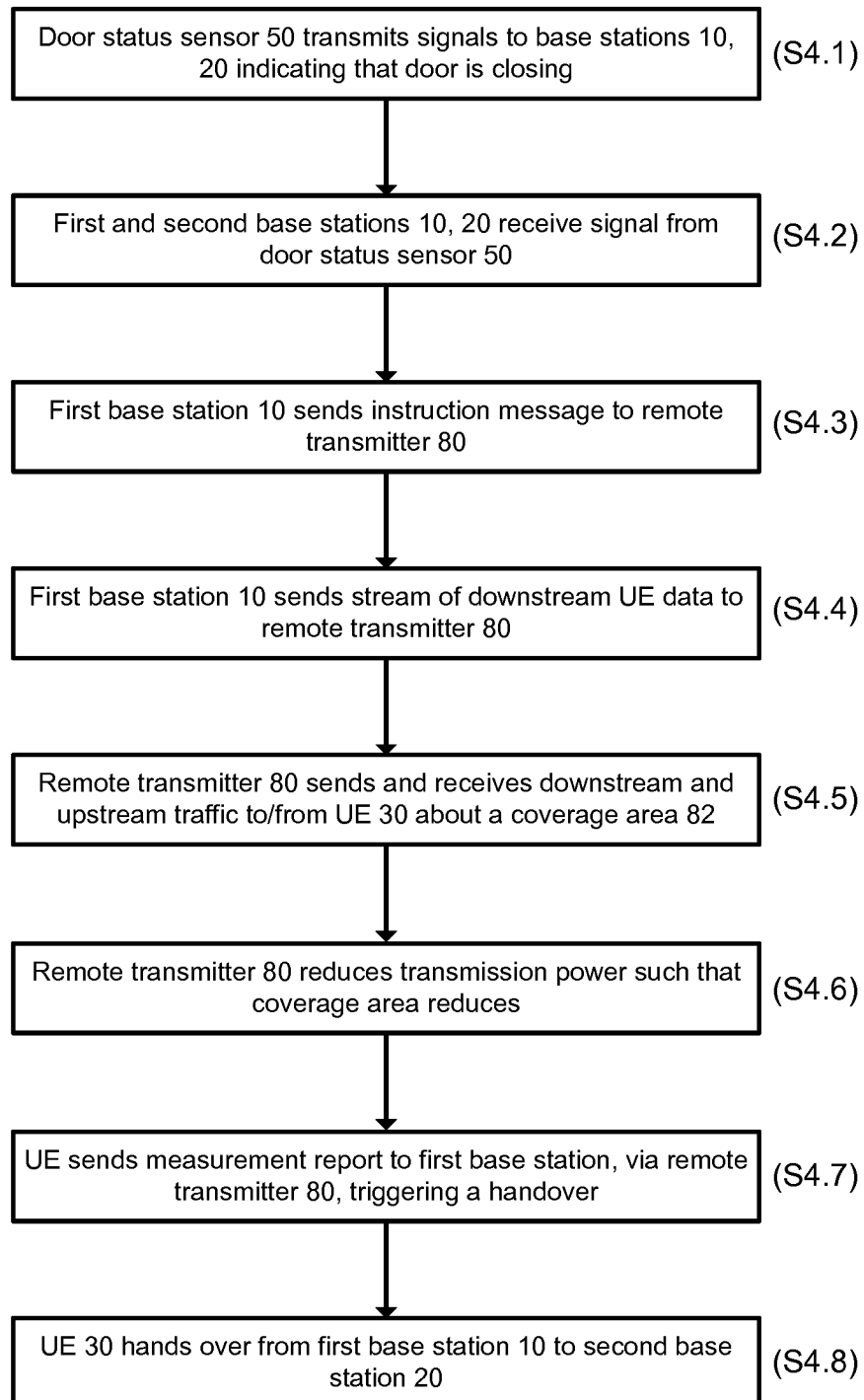

Figure 12

INTERNATIONAL SEARCH REPORT

International application No
PCT/EP2017/082586

A. CLASSIFICATION OF SUBJECT MATTER
INV. H04W36/32
ADD.
According to International Patent Classification (IPC) or to both national classification and IPC

B. FIELDS SEARCHED
Minimum documentation searched (classification system followed by classification symbols)
H04W
Documentation searched other than minimum documentation to the extent that such documents are included in the fields searched

Electronic data base consulted during the international search (name of data base and, where practicable, search terms used)
EPO-Internal, INSPEC, WPI Data

C. DOCUMENTS CONSIDERED TO BE RELEVANT		
Category*	Citation of document, with indication, where appropriate, of the relevant passages	Relevant to claim No.
X	US 2013/237245 A1 (TINNAKORNSRISUPHAP PEERAPOL [US] ET AL) 12 September 2013 (2013-09-12) the whole document	1-17
X	WO 2009/121833 A1 (VODAFONE PLC [GB]; BECK ROGER [GB]; PROCTOR TOBY [GB]) 8 October 2009 (2009-10-08) abstract page 23, line 15 - page 24, line 20	1-17
A	US 2005/048972 A1 (DORENBOSCH JHEROEN P [US] ET AL) 3 March 2005 (2005-03-03) abstract ----- -/--	1-17

Further documents are listed in the continuation of Box C.

See patent family annex.

* Special categories of cited documents :

- "A" document defining the general state of the art which is not considered to be of particular relevance
- "E" earlier application or patent but published on or after the international filing date
- "L" document which may throw doubts on priority claim(s) or which is cited to establish the publication date of another citation or other special reason (as specified)
- "O" document referring to an oral disclosure, use, exhibition or other means
- "P" document published prior to the international filing date but later than the priority date claimed

"T" later document published after the international filing date or priority date and not in conflict with the application but cited to understand the principle or theory underlying the invention

"X" document of particular relevance; the claimed invention cannot be considered novel or cannot be considered to involve an inventive step when the document is taken alone

"Y" document of particular relevance; the claimed invention cannot be considered to involve an inventive step when the document is combined with one or more other such documents, such combination being obvious to a person skilled in the art

"&" document member of the same patent family

Date of the actual completion of the international search 17 January 2018	Date of mailing of the international search report 09/02/2018
Name and mailing address of the ISA/ European Patent Office, P.B. 5818 Patentlaan 2 NL - 2280 HV Rijswijk Tel. (+31-70) 340-2040, Fax: (+31-70) 340-3016	Authorized officer Carnerero Álvaro, F

INTERNATIONAL SEARCH REPORT

International application No
PCT/EP2017/082586

C(Continuation). DOCUMENTS CONSIDERED TO BE RELEVANT		
Category*	Citation of document, with indication, where appropriate, of the relevant passages	Relevant to claim No.
A	US 2015/334604 A1 (BANKS ROBERT EDWARD [GB] ET AL) 19 November 2015 (2015-11-19) paragraph [0018] paragraph [0029] paragraph [0038] paragraph [0072] paragraph [0074] paragraph [0089] paragraph [0093] - paragraph [0097] -----	1-17

INTERNATIONAL SEARCH REPORT

Information on patent family members

International application No PCT/EP2017/082586

Patent document cited in search report	Publication date	Patent family member(s)	Publication date	
US 2013237245	A1	12-09-2013	CN 104160738 A	19-11-2014
			JP 6147773 B2	14-06-2017
			JP 2015509692 A	30-03-2015
			US 2013237245 A1	12-09-2013
			WO 2013134724 A1	12-09-2013

WO 2009121833	A1	08-10-2009	EP 2266337 A1	29-12-2010
			ES 2547535 T3	07-10-2015
			GB 2459434 A	28-10-2009
			US 2012140642 A1	07-06-2012
			US 2015023208 A1	22-01-2015
			WO 2009121833 A1	08-10-2009

US 2005048972	A1	03-03-2005	EP 1661419 A1	31-05-2006
			JP 2007503759 A	22-02-2007
			US 2005048972 A1	03-03-2005
			WO 2005022937 A1	10-03-2005

US 2015334604	A1	19-11-2015	EP 2947916 A2	25-11-2015
			GB 2526286 A	25-11-2015
			US 2015334604 A1	19-11-2015
