

(12) INTERNATIONAL APPLICATION PUBLISHED UNDER THE PATENT COOPERATION TREATY (PCT)

(19) World Intellectual Property Organization
International Bureau



(43) International Publication Date
13 February 2003 (13.02.2003)

PCT

(10) International Publication Number
WO 03/011755 A1

(51) International Patent Classification⁷: **C01B 31/02**

(21) International Application Number: PCT/GB02/03438

(22) International Filing Date: 26 July 2002 (26.07.2002)

(25) Filing Language: English

(26) Publication Language: English

(30) Priority Data:
0118341.7 27 July 2001 (27.07.2001) GB
0118276.5 27 July 2001 (27.07.2001) GB
0118279.9 27 July 2001 (27.07.2001) GB

(71) Applicant (for all designated States except US): **UNIVERSITY OF SURREY** [GB/GB]; Guildford, Surrey GU2 7XH (GB).

(72) Inventors; and

(75) Inventors/Applicants (for US only): **SILVA, Professor Sembukutiarachilage Ravi** [GB/GB]; 29 Verran

Road, Camberley, Surrey GU15 2ND (GB). **HAQ, Sajad** [GB/GB]; 3 Alder Road, Glasgow G43 2UY (GB). **BOSKOVIC, Bojan, O.** [YU/GB]; 51 Kingfisher Close, St. Peters, Worcester WR5 3RY (GB).

(74) Agents: **MUSKER, David, Charles** et al.; R.G.C. Jenkins & Co., 26 Caxton Street, London SW1H 0RJ (GB).

(81) Designated States (national): AE, AG, AL, AM, AT, AU, AZ, BA, BB, BG, BR, BY, BZ, CA, CH, CN, CO, CR, CU, CZ, DE, DK, DM, DZ, EC, EE, ES, FI, GB, GD, GE, GH, GM, HR, HU, ID, IL, IN, IS, JP, KE, KG, KP, KR, KZ, LC, LK, LR, LS, LT, LU, LV, MA, MD, MG, MK, MN, MW, MX, MZ, NO, NZ, OM, PH, PL, PT, RO, RU, SD, SE, SG, SI, SK, SL, TJ, TM, TN, TR, TT, TZ, UA, UG, US, UZ, VN, YU, ZA, ZM, ZW.

(84) Designated States (regional): ARIPO patent (GH, GM, KE, LS, MW, MZ, SD, SL, SZ, TZ, UG, ZM, ZW), Eurasian patent (AM, AZ, BY, KG, KZ, MD, RU, TJ, TM), European patent (AT, BE, BG, CH, CY, CZ, DE, DK, EE, ES, FI, FR, GB, GR, IE, IT, LU, MC, NL, PT, SE, SK, TR), OAPI patent (BF, BJ, CF, CG, CI, CM, GA, GN, GQ, GW, ML, MR, NE, SN, TD, TG).

[Continued on next page]

(54) Title: PRODUCTION OF CARBON NANOTUBES

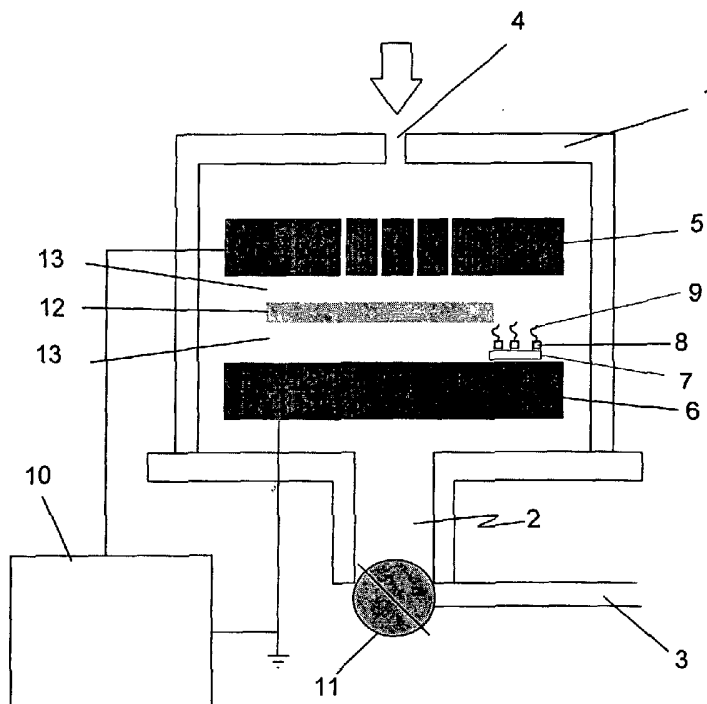

(57) Abstract: A method of forming carbon nanotubes by plasma enhanced chemical vapour deposition using a carbon containing gas plasma, wherein the carbon nanotubes are not formed on a substrate at a temperature 300 °C or above.



WO 03/011755 A1



Published:

- *with international search report*
- *before the expiration of the time limit for amending the claims and to be republished in the event of receipt of amendments*

For two-letter codes and other abbreviations, refer to the "Guidance Notes on Codes and Abbreviations" appearing at the beginning of each regular issue of the PCT Gazette.

PRODUCTION OF CARBON NANOTUBES

The present invention relates to a method of making carbon nanotubes, in particular a method of forming carbon nanotubes using plasma enhanced
5 chemical vapour deposition (PECVD). The term 'carbon nanotubes' (CNTs) is used herein as a generic term to embrace single-walled and multi-walled carbon nanotubes, carbon nanofibres, carbon nanofilaments and carbon nanoropes (ropes of carbon nanotubes).

The existence of CNTs is well documented in academic literature,
10 since 1991 when Iijima first observed them in carbon arc deposits (Iijima S., Nature, 354 (1991) 56). There are many different ways of making them, including arc discharge, laser vaporisation, electron beam and catalytic pyrolysis. Other known methods are to use chemical vapour deposition (CVD) and plasma enhanced CVD (PECVD).

15 Background information discussing CNTs is disclosed in prior art document 'Nanotubes for electronics' in the December 2000 issue of Scientific American (P.G. Collins et al.) pp. 38 – 45. This document discloses a method of CNT production, wherein a substrate is placed in a vacuum oven or flow tube, heated to temperatures of the order of 500°C to 1200°C and a carbon-
20 containing gas such as methane is introduced optionally in the presence of a transition metal-containing catalyst, whereupon it decomposes into, inter alia, carbon vapour. Some of the carbon vapour forms or condenses as carbon nanotubes.

Other prior art documents concerned with CNT production are 'Crystalline Ropes of Metallic Carbon Nanotubes' in Science, Reports pp.483-487, vol 273, 26 July 1996; 'Tensile strength of single walled carbon nanotubes directly measured from their macroscopic ropes', Applied Physics Letters, Vol 77, No 20, 13th November 2000; and 'Bulk Morphology and diameter distribution of single-walled carbon nanotubes synthesised by catalytic decomposition of hydrocarbons', chemical physics letters, 289 (1998) 602-610.

A further technique for growing CNTs is disclosed in the International patent application WO 99/65821, wherein a method of forming CNTs on materials such as glass, silica, quartz and silicon using Plasma Enhanced Chemical Vapour Deposition (PECVD) is disclosed. This 'hot filament' PECVD method uses high gas temperatures of between 300°C and 700°C, so as to deposit CNTs on, for example, glass having a strain point temperature of 666°C. A heat filament situated above the material directly heats the material on to which the CNTs are deposited, the heat filament providing the energy required to produce the plasma above the substrate, and therefore provide the mechanism to disassociate the hydrocarbon gas and form CNTs using a catalyst. The glass onto which CNTs are deposited can then be used in the production of flat panel displays.

CNTs have other known applications, such as hydrogen storage devices. This application is particularly suited to CNTs as H₂ is approximately 0.28nm in diameter, whereas the approximate distance

between graphene layers in multiwalled CNTs is approximately 0.34nm. Thus, CNTs provide a means of storing H₂ in an efficient manner for use in fuel cells.

It is also possible to use CNTs in applications such as electrochemical capacitors (super-capacitors), nanoelectronics, electronic and photonic device applications, field emission devices, polymer composite fabrication, MEM's (micro electro-mechanical systems), microwave resonators, structural materials, and electronic semiconductor materials. A composite material could consist of glass, metal, ceramic, polymer, graphite and a mixture of any of these.

In known polymer composite fabrication techniques, CNTs are grown in a chamber using a known high temperature technique. The CNTs are removed from the chamber by, for example, scraping the CNTs off the chamber wall. The CNTs are then mixed with the polymer to provide a strengthened composite material.

A further example of CNT production is given in EP1129990A1, wherein a method is disclosed using high frequency, R.F. and microwave PECVD to deposit CNTs on a substrate heated to a temperature between 500°C and 1000°C.

All of these prior methods have substantial substrate temperatures, ranging from 300°C up to and above 1000°C, for the necessary energy input required to produce CNTs.

The present invention has been devised and modified to provide an improved low temperature, in particular room temperature, PECVD process for the formation and growth of CNTs. With the present invention it is now possible to deposit CNTs onto substrates at much lower temperatures than
5 previously carried out, providing an increase in the commercial potential of CNT production, especially where CNTs are applied to commercially significant materials that could not be used with the known high temperature methods of deposition.

According to this invention, there is provided a method of forming
10 carbon nanotubes by plasma enhanced chemical vapour deposition using a carbon containing gas plasma, wherein the carbon nanotubes are not formed on a substrate at a temperature 300°C or above.

Other aspects and embodiments are as described or claimed hereafter.

In order that the invention may be illustrated, more easily appreciated
15 and readily carried into effect by those skilled in the art, embodiments thereof will now be described by way of non-limiting example only, with reference to the accompanying drawings in which:

Figure 1 is a schematic illustration of a suitable radio-frequency plasma chamber for forming and growing CNTs upon a substrate, according
20 to an embodiment of the present invention;

Figure 2 shows a plasma chamber using primary and secondary power supplies, e.g. combined microwave and radio-frequency, according to an embodiment of the present invention;

Figure 3 is a typical scanning electron micrograph (SEM) of CNTs produced at room temperature in radio-frequency methane plasma on Ni catalyst particles, according to an embodiment of the present invention;

5 Figure 4A is a typical transmission electron micrograph (TEM) of an radio-frequency PECVD produced nanotube containing a terminal nickel particle, produced according to an embodiment of the present invention;

Figure 4B is an energy filtered TEM image showing a nickel map, indicating the nickel content (in white) at the tip of a nanotube produced according to an embodiment of the present invention;

10 Figure 4C is a close up of the TEM shown in Figure 4A, indicating the herringbone structure of the CNTs produced according to an embodiment of the present invention;

Figure 4D shows the proposed method of formation of the CNTs produced according to an embodiment of the present invention;

15 Figure 5, consisting of Figures 5A and 5B, shows SEM pictures of CNTs formed in example 9 using combined radio-frequency and microwave plasma enhanced CVD;

20 Figure 6 is a TEM picture of CNTs exhibiting bi-directional growth, formed in example 10, using combined radio-frequency and microwave plasma enhanced CVD;

Figure 7, consisting of Figures 7A and 7B, shows TEM pictures of CNTs exhibiting branching at a 'Y'-shaped junction, formed in example 11, using combined radio-frequency and microwave plasma enhanced CVD;

Figure 8 is an SEM picture of ropes of CNTs produced (as bundles of closely packed nanotubes), formed in example 12 after nitric acid treatment, using combined radio-frequency and microwave plasma enhanced CVD; and

5 Figure 9 is an SEM picture of ropes of CNTs produced (as bundles of densely packed nanotubes) after nitric acid treatment using combined radio-frequency and microwave plasma enhanced CVD.

DESCRIPTION OF PREFERRED EMBODIMENT

Referring firstly to Figure 1, the plasma chamber of a Plasma
10 Technology DP800 radio-frequency PECVD system is used as shown diagrammatically. A vacuum chamber housing 1 is capable of evacuation via channels 2 and 3 controlled by an auto pressure throttle valve 11. Evacuation of the interior of the chamber 1 is effected via a roots/rotary pump in communication with channel 3. The chamber 1 has a gas inlet 4 for receiving
15 a flow of the required gas or gaseous mixture, typically a hydrocarbon gas such as methane CH₄.

An earthed electrode 6 is provided in the lower part of the chamber, whilst a powered electrode 5 is provided in the upper part of the chamber and connected to the appropriate power source. In this embodiment, the power
20 source used is a 13.56MHz radio-frequency power supply unit (PSU) 10.

A substrate 7 is coated with a nickel powder (99% purity) with an average particle diameter from 4 to 7µm obtained from Goodfellow Cambridge Ltd. The substrate used in this embodiment is a graphite plate

substrate, but it will be obvious to a skilled person that any other substrate may be used. Approximately 50mg of the nickel powder catalyst was dispersed as a uniform thin layer on the top of the substrate.

The substrate is placed on the earthed electrode and the chamber is
5 evacuated. The substrate 7 is shown in Figure 1 coated with ultrafine nickel powder 8 (shown in exaggerated form in the Figure) upon which the CNTs 9 (shown in exaggerated form in the Figure) are formed. Methane gas of 99.999% (five 9s) purity is allowed to flow into the chamber at a rate of 30 sccm ($\text{cm}^3/\text{minute}$), using a suitable device such as a mass flow controller.
10 Radio-frequency power is switched on at a power setting of 300W in order to strike a plasma. After the plasma is struck, the gas flow rate is adjusted to provide a working pressure of approximately 133.3 Pascal (1 Torr) and the radio-frequency power supply 10 is adjusted to operate at 200W to maintain the plasma 12. The plasma has a sheathed region 13 in which the substrate 7
15 is situated. The substrate 7 may be subjected to only a low potential difference e.g. of the order less than 40V, preferably less than 20V to facilitate a gentle growth process for the carbon nanotubes. The potential difference to some extent determines the direction of growth and alignment of the CNTs.

20 It is the very high temperature of the plasma that provides the necessary energy to produce the required reaction of the gases in the chamber, thereby allowing the radio-frequency system to transport the disassociated hydrocarbon species and carbon ions to the substrate and initialise the CNT

growth from the catalyst. The plasma temperature is approximately 2-3 eV, which equates to approximately 24000 to 36000 Kelvin.

The electrodes 5, 6 are temperature controlled by using a combination of a water-cooling system (not shown) and heaters so, as the plasma is generated and maintained, the electrodes are kept at the desired temperature. The temperature of the substrate on the electrodes during a plasma in this embodiment is between 29°C and 32°C. This low temperature substrate temperature allows for a wide variety of previously unused substrates to be used for CNT deposition.

During different process runs carried out, various temperatures ranging from room temperature to 250°C were used. Although it will be clear to a skilled person that higher temperatures could be used. Also, various process times were used from 10 to 30 minutes

A sample of process parameters from eight separate runs using the apparatus shown in Figure 1 is shown in Table 1 as Examples 1 to 8.

TABLE 1

Example	Catalyst	Substrate	Hydrocarbon	Radio Frequency	Time	Micro-wave Energy	Temp
1	Ni powder 4-7 μ m	Graphite	CH ₄ f=30scm 99.9% pure	13.56 MHz, 200w	30min	None	30°C
2	Ni powder 4-7 μ m	Graphite	CH ₄ f=30scm 99.9% pure	13.56 MHz, 200w	15min	None	250°C
3	Ni powder 4-7 μ m	Graphite	CH ₄ f=30scm 99.9% pure	13.56 MHz, 200w	15min	None	250°C
4	Ni powder 4-7 μ m	Graphite	CH ₄ f=30scm 99.9% pure	13.56 MHz, 200w	30min	None	30°C
5	Ni powder 4-7 μ m	Plastics	CH ₄ f=30scm 99.9% pure	13.56 MHz, 200w	30min	None	30°C
6	Ni powder 4-7 μ m	Silicon	CH ₄ f=30scm 99.9% pure	13.56 MHz, 200w	30min	None	100°C
7	Ni powder 4-7 μ m	Plastics	CH ₄ f=30scm 99.9% pure	13.56 MHz, 200w	30min	None	30°C
8	Ni powder 4-7 μ m	Plastics	CH ₄ f=30scm 99.9% pure	13.56 MHz, 200w	30min	None	30°C

The characterisations of the nanotubes formed were performed on a Hitachi S-4000 field emission scanning electron microscope (SEM) and a Philips CM 200 transmission electron microscope (TEM). The samples studied by TEM were prepared by ultrasonic dispersion of 'as grown' samples in isopropanol, a drop of the suspension was then deposited on a thin amorphous carbon film supported on a copper grid. The samples were then allowed to dry.

An SEM micrograph of example 1 showing carbon nanotubes grown on a substrate kept at room temperature in a radio-frequency plasma-enhanced CVD is provided in Figure 3. Figure 3 shows nickel catalyst particles at the end of the CNTs, as white spots, suggesting a tip growth model. The tip growth model is depicted in stages (i) to (iv) in Figure 4D. TEM studies have shown the multi-walled nature of the produced nanotubes with the associated catalyst particle at the tip, as shown in Figure 4A. Figure 4B shows the nickel content at the tip of the CNT, using an energy filtered TEM image showing a nickel map.

The interlayer spacing of 0.34nm typical for graphene sheets along the CNT axis was found in the expanded region of the nanotube. The typical lengths of carbon nanotubes produced varied from 0.5 to 5 μ m, with diameters ranging from 5 to 15nm. Adjusting the deposition times, gas flows, catalyst particle conditions, gas concentrations & type, and D.C. bias applied to the substrate may vary the length and thickness of CNTs.

Figure 4C shows a TEM structure analysis of the carbon nanotubes. The TEM shows graphite platelets, which are usually aligned parallel to the side facets of the cone-shaped catalyst particle in the form of a "herringbone" stacking arrangement at the growth end of the nanotube.

It has been shown from the discussed method that radio-frequency plasmas can produce carbon nanotubes, which grow on a substrate kept at a temperature below 300°C and in particular at room temperature. This low temperature plasma enhanced CVD method is suitable for growing well-

aligned carbon nanotubes selectively by using the metal catalytic effect, where the temperature at the point of CNT growth permits the use of temperature sensitive substrates.

In general, the carbon nanotubes catalytically produced tended to
5 adopt a whisker-like form where the catalyst particle is carried away from the substrate during the growth process and remains at the tip of the nanotube. The diameter of the carbon nanotube was the same as that of the nickel particle at their head. Catalyst particles at the growing end of the nanotube were usually "pear-shaped", and completely enveloped by a layer of carbon.
10 Moreover, each nickel particle was responsible for the growth of a single nanotube, unidirectional or bi-directional. Most carbon nanotubes produced were composed of multiple co-axial tubes with the spacing between tube walls being approximately the graphene interplanar distance of 0.34nm. However, it is also possible to produce growth of the carbon nanotubes in
15 coiled form.

APPLICATIONS

This new method of production allows for the formation of CNTs on commercially significant materials, and growth over relative large areas.
20 Many new CNT applications have since become available due to the large number of available materials for use as substrates on which CNTs can now be deposited because of the lower temperature process. Highly temperature sensitive materials such as plastics, or any other types of polymer, ceramics,

textiles, paper, or even organic materials may now be used as materials for CNT deposition.

Examples of CNT applications available through using this method are the deposition of CNTs on to textiles for use in applying printed circuits to clothing and the reinforcement of material fibres; the production of flexible
5 displays using CNTs; the deposition of CNTs onto living organisms, and due to the inert nature of CNTs, the application of CNT devices internally placed in living organisms. It may also be possible to use nanotubes as DNA storage devices.

10 An example of a possible application using this method is to insert an item of clothing such as the cuff of a shirt into a CNT deposition chamber. Prior to being inserted in to the chamber, the cuff would be coated with a nickel catalyst in a particular pattern so as to be able to form a printed circuit. The deposition of the CNTs, in-situ within the chamber, would produce a
15 printed circuit in the same pattern as the nickel catalyst pattern deposited on the cuff. The circuit could be, for example, part of a mobile communication device enabling people to communicate with each other without having to carry mobile phones as separate devices. This method therefore provides an efficient way of depositing electrical circuits onto fabrics.

20 Due to the inertness of carbon it is possible to deposit CNTs on organic material, providing a wide range of suitable applications. An example of using this method on organic material is the deposition of a pacemaker circuit onto a heart prior to a transplant. Firstly a catalyst material is placed

on the surface of a heart suitable for transplantation in a pattern required to form a pacemaker device. The heart is then inserted into a suitably clean chamber, and the CNTs are grown. Once the CNTs have grown, the heart is then removed and transplanted into the patient.

5 A further example of using this method in a new application is the deposition of CNTs onto flexible transparent sheets for use in flexible display applications. A material such as PVA (polyvinyl acetate) could be used as a substrate in the same manner as the applications discussed above.

10 It is also possible to use this method of forming CNTs to provide improved ceramic material products. For example, the CNTs are deposited in-situ within the chamber into ceramic powder, thereby forming a ceramic composite. The ceramic composite mixture is removed from the chamber and formed into ceramic devices. This method provides a way of reinforcing ceramic materials, and providing conductive ceramics.

15 A further example is to place polymer resin into the chamber and deposit the CNTs in-situ into the resin. The resultant polymer composite is then available for use as a conductive and/or reinforced material.

20 A further example of an application in which CNTs may be used is to form EMI (Electro Magnetic Impulse). The CNTs may be formed in a composite material (e.g. glass, metal, ceramic, polymer, graphite or any combination of these), wherein the composite material is then able to shield devices or people from RF or microwave radiation.

CNTs may also be grown on a paper substrate using the described method, whereby CNTs are deposited on a paper substrate within the chamber to form a circuit using a catalyst material. The paper circuit may then be used as a biodegradable electronic device, which is easily and cheaply
5 manufactured, and can be thrown away when no longer required.

CNTs have special qualities such as good conductivity and resistance to temperature. Nanotubes are very stiff and sharp, whilst nanofibres are slightly more flexible. Ropes of CNTs have good tensile strength, which is useful in applications where durability and power are required. Also, as
10 carbon is not easily detectable, it is also possible to make CNT circuits that can be hidden.

It is now possible for any of these products or devices, including the known applications discussed in the introduction, to be fabricated more economically under a less restrictive environment.

15

DESCRIPTION OF SECOND EMBODIMENT

A procedure for the production of carbon nanotubes using a combination of radio-frequency and microwave energy will now be discussed.

Referring to Figure 2, there is shown a chamber 21 capable of
20 evacuation firstly via a rotary pump 22, and then after a certain pressure is reached, via a turbo pump 23. An earthed electrode 24 is shown in similar fashion to the chamber shown in Figure 1. However, the chamber 21 is adapted to receive a microwave generator 25 consisting of a magnetron 26

and a tuner 27. The microwave generator's grid electrode 28 serves as the powered electrode for the purposes of applying radio-frequency power across the earthed electrode 24 and powered electrode 28. The microwave generator is of a type known per se and arranged to direct microwave radiation into the plasma-generating region 29. The microwave power source is used in combination with the radio-frequency power source in order to provide energy for the plasma.

In use, a substrate (not shown) such as a graphite plate is dispersed with approximately 50 mg of nickel powder catalyst as a uniform thin layer on the top of a graphite substrate. The catalyst used for carbon nanotubes growth is nickel powder (99% purity), with average particle diameter from 4 to 7 μm obtained from Goodfellow Cambridge Ltd.

The substrate is placed upon the earthed electrode 24 with the electrode 24 being water-cooled (not shown). A carbon containing gas, such as methane gas of 99.999% (five 9s) purity (obtained from BOC Ltd.) is used. The gas is introduced in to the chamber prior to switching on the radio-frequency and microwave power supplies. The gas flow rate is set to 70 sccm ($\text{cm}^3/\text{minute}$) and is maintained at a constant flow rate. Once the gas flow has started flowing into the chamber a plasma is struck, as discussed in the previous embodiment. However, in this embodiment combined radio-frequency and microwave plasma enhanced CVD is performed with radio-frequency power ranging from 100W–200W and microwave power ranging

from 240 to 840W. The microwave and radio-frequency plasma input power is kept constant during the CNT deposition.

Various process times were used from 15 to 30 minutes, with a process pressure of 1.6 Pascal (12 mTorr).

5 The carbon nanotubes form and grow from the metal catalyst particles, within the sheathed region of the plasma. The substrate was partly heated directly by the plasma without an additional heating source, however the temperature of the substrate during the CNT deposition process was recorded as 24°C.

10 The nanotubes of examples 9 to 13, as shown in Table 2, were grown in a combined radio-frequency and microwave plasma enhanced CVD system, as depicted in Figure 2, using a 2.45 GHz microwave power supply. The following table (TABLE 2) shows the results of five process runs that used combined radio-frequency and microwave plasma enhanced CVD.

TABLE 2

Example	Catalyst	Substrate	Hydrocarbon	Radio Frequency	Time	Micro-wave Energy	Temp
9	Ni powder 4-7 μ m	Silicon	CH ₄ f=70scm 99.9% pure	13.56 MHz, 100w	15min	2.45GHz 500w	<100°C
10	Ni powder 4-7 μ m	Glass	CH ₄ f=70scm 99.9% pure	13.56 MHz, 100w	15min	2.45GHz 840w	<100°C
11	Ni powder 4-7 μ m	Graphite	CH ₄ f=70scm 99.9% pure	13.56 MHz, 100w	15min	2.45GHz 240w	<100°C
12 *	Ni powder 4-7 μ m	Silicon	CH ₄ f=70scm 99.9% pure	13.56 MHz, 100w	15min	2.45GHz 840w	<100°C
13 *	Ni powder 4-7 μ m	Glass	CH ₄ f=70scm 99.9% pure	13.56 MHz, 100w	15min	2.45GHz 840w	<100°C

*After treatment in 35% nitric acid for 4 minutes.

The average length of CNTs produced using combined radio-frequency and microwave power was between 0.5 and 5 μ m with a thickness from 5 to 80 nm. Varying different parameters as discussed in the preferred embodiment may of course produce various different lengths and thickness of CNTs.

Bi-directional growth of CNTs grown by combined radio-frequency and microwave plasma enhanced CVD methods was observed, as grown in example 10 & 11 and shown in Figures 6, 7A & 7B.

Figure 6 shows the bi-directional growth characteristics seen using the combined radio-frequency and microwave PECVD CNT deposition method. The diamond-shaped catalyst particle can be seen in Figure 6 situated in the middle of the CNT.

In addition to the unidirectional and bi-directional morphologies, CNTs grown by the combined radio-frequency microwave PECVD method have unexpectedly shown branching during growth and “Y” and “H” shaped junctions have been formed, as shown in Figures 7A and 7B. The branches of
5 a CNT growth were of the order of 20nm in diameter, whilst the roots were of the order of 40nm in diameter.

In Figure 7A an SEM micrograph of the area with interconnecting networks of CNTs is shown. Figure 7B is a magnification of the rectangular area marked in Fig. 7A.

10 The synthesis of connections between two or more different CNTs is an important step in the development of carbon nanotube-based electronic devices and conducting structures, by creating interconnections for electronic devices on a nanometer scale. Interconnecting networks of branched CNTs are very important for the creation of a new generation of conducting
15 composite materials, as a network may be grown without any need to rearrange grown individual CNTs to form a network.

DESCRIPTION OF THIRD EMBODIMENT

20 Although the CNTs are deposited onto substrates within the chamber in the two previous embodiments, it is also possible to produce CNTs within the chamber and then apply them to a substrate that is external to the chamber. The temperature and atmospheric environment of the substrate can be easily controlled, as the substrate is not in close proximity to the plasma.

A plasma is struck as discussed in either of the previous embodiments. However, a substrate with a catalyst particle layer is not placed within the chamber prior to striking the plasma. Instead, catalyst particles are injected into the plasma area of the chamber, in which, the catalyst particles react with the plasma as discussed previously and CNTs are grown. The catalyst particles may, for example, be dissolved in a liquid such as benzene and injected into the chamber. Alternatively, an aerosol may be used to inject the catalyst.

The CNTs formed from the catalyst particles are then extracted from the chamber by any means possible. For example, a pump may direct the CNTs through a venting channel, or an electromagnetic force may be set up around the chamber directing the CNTs towards a suitable chamber exit point.

After the CNTs are collected from the chamber, they are deposited onto a substrate of choice, such as previously discussed. The CNTs are deposited onto a substrate in a predefined pattern according to the application requirements. For example, the substrates may be placed on to a moving belt, which is moved underneath a nozzle that emits CNTs, the CNTs deposited in a predetermined pattern. Alternatively, the substrates may be placed on a stationary surface, whilst the CNT emitting nozzle is moved over the top of the substrates, depositing the CNTs in the required pattern.

This method clarifies that additional heat sources are not required to heat substrates to provide the mechanism for growth of CNTs, and all that is

required is a carbon containing plasma in which the catalyst particles can react.

In this method, it is not necessary to stop CNT production in order to insert subsequent substrates or groups of substrates, as in previous
5 embodiments. Therefore, this method provides a higher throughput due to the continuous CNT production, extraction and deposition onto external substrates.

DESCRIPTION OF FOURTH EMBODIMENT

10 Using any of the methods described previously it is also possible to produce ropes of roughly-aligned CNTs, which have been synthesised after nickel catalysed plasma enhanced chemical vapour deposition (PECVD) of methane at substrate temperatures below 300°C, and in particular at room temperature.

15 After production of the CNTs using the methods described previously, the chamber is vented to atmospheric pressure and the substrate on which CNTs were deposited was removed from the chamber. The mixture of the synthesised CNTs and the remaining nickel powder catalyst was removed from the substrate and then placed in an appropriately acid proof container.

20 The mixture of CNTs and nickel powder was covered in a 35% nitric acid solution for 3 to 10 minutes. The mixture was then rinsed with de-ionised water to remove the nitric acid from the mixture. CNT ropes were produced in dried sediment, as seen in a scanning electron microscope (SEM)

examination. Rope diameters were from 20 μ m up to 80 μ m, and the lengths of the ropes were up to a few millimetres.

It is thought that the CNTs were self-organised into ropes by hydrophobic adhesion in de-ionised water, which was used to discontinue
5 nitric acid action, and bundled together by van der Waals force.

The size of these ropes can offer easy manipulation with special opportunities for their characterisation and applications, in particular the utilisation of their inherent strength.

For example, the ropes may be intertwined with fabrics to provide for
10 a reinforced protective garment.

Ropes produced using this method may be used in composite materials (e.g. glass, metal, ceramic, polymer, graphite and any mixture thereof). Ropes may also be used in any of the applications discussed previously

15 **DISCUSSION OF FURTHER EMBODIMENTS**

Catalytic carbon nanotubes (CNT) were grown with the substrates, upon which the CNTs were formed, being kept at temperatures below 300°C, and in particular down to room temperature using radio-frequency plasma chemical vapour deposition (CVD) and combined radio-frequency microwave
20 plasma CVD methods. Instead of using high temperatures (300°C+) to provide an appropriate growth environment for the CNT, the present invention utilises hydrocarbon plasmas to provide the energy dynamics necessary for dissociation of the carbon and subsequent catalytic growth on

transition metal particles, with a wide range of different substrates being kept at temperatures below 300°C and in particular down to room temperature.

It will be apparent to a skilled person that the term plasma used herein embraces an ionised gas, or ionised vapour, or a collection of ionised particles. The plasma may be in the form of a beam, such as a plasma beam which can be produced e.g. by a filtered cathodic vacuum arc apparatus. The plasma can be, for example, generated by microwave energy or by radio-frequency energy or by a combination of microwave energy and radio-frequency energy. Also, it would be clear to the skilled person that ECR (electron cyclotron resonance) microwave plasma could be utilised for the growth of CNTs. As such, any type of plasma may be used and may be generated by a primary power source optionally combined with at least one secondary power source.

It will be also be apparent to a skilled person that any gaseous medium containing carbon can be used. The gaseous medium is preferably a hydrocarbon gas such as methane, acetylene or ethylene. However, any other carbon-containing gases could be used, such as, for example, carbon monoxide or carbon dioxide. The gaseous medium can also be a mixture of carbon-containing gases, or a mixture of a carbon containing gas with a carrier gas such as Nitrogen (N₂), Hydrogen (H₂), or Argon (Ar). Whichever carbon-containing gas or mixture of gases is used, it is preferred that the gas used during CNT production is non-destructive or non-etching in the plasma state. It is therefore preferred to avoid any gas which, when ionised, forms

ionic species likely to adversely affect the structure or operation of the plasma chamber. However, it is possible to use ammonia (NH_3) as a carrier gas, where the ammonia is used to react with the catalyst.

It will also be apparent to a skilled person that it is preferred for the gaseous medium to be of high purity, for example greater than 98% pure. However, less pure gases may be used.

It will also be apparent to a skilled person that the plasma methods are preferably effected within a suitable vacuum chamber constructed to generate, maintain and withstand a gaseous plasma. Suitable plasma chambers are known per se and will not require further substantial elaboration to the notional skilled person.

It will also be apparent to a skilled person that, although in the embodiment described above the microwave power supplied was at a frequency of 2.45 GHz, the frequency used could be any frequency in the band 2 to 3 GHz.

It would also be apparent to a skilled person that, although the microwave power applied in the embodiment described above was in the range 240W to 840W, the power range applied could be between 20W and 6kW. These levels of microwave power are preferably applied and maintained throughout the period of nanotube growth required e.g. for at least 10 minutes preferably at least 15 minutes, more preferably at least 20 minutes. The maximum applied time is not especially critical and is likely to be

influenced by economic factors, and the required characteristics of the nanotubes.

It will also be apparent to a skilled person that radio-frequency power may be applied alone, or combined with microwave power to provide a plasma, and that although the frequency of the radio-frequency power used in the embodiments described above was set to 13.56 MHz that any frequency in the band 90KHz – 30MHz may be used. Also, although in the embodiments discussed above the power was set to 200W, it will be apparent that power settings in the range 20W – 10kW can be used.

It will also be apparent to a skilled person that the power supply unit could be a pulsed or DC power supply. If a pulsed power supply is used to generate or support the plasma, it may be of a frequency in the range 25 to 250kHz and of a power up to about 10kW. The plasma could be generated using a pulsed power supply combined with radio-frequency and/or microwave energy.

Although the two embodiments using radio-frequency energy alone and radio-frequency energy combined with microwave energy show substrate temperatures of 24°C to 32°C, it will be apparent to the skilled person that any substrate temperature may be obtained by using chiller units with antifreeze to cool the substrates down, and heater units in the electrodes to heat the substrates up. For example, temperatures may be below 300°C down to room temperature (20°C to 35°C), or even down to 0°C and lower. It will also be clear to a skilled person that it may be possible to use liquid nitrogen

on the substrates to produce CNTs using a hot filament PECVD method, with the substrate being kept at a low temperature.

It will be apparent to a skilled person that it is preferred for a metal catalyst to be present, for example a transition metal such as nickel, cobalt, iron, or any mixture thereof upon a substrate as previously discussed.

It will also be apparent to a skilled person that although nickel powder of 99% purity, and an average particle diameter of 4-7 μ m was used in the specific embodiments that it is possible to use a less pure, or indeed a higher purity nickel powder, and varying sized particles.

Also, it will be apparent to the skilled person that the catalyst need not to be powder. It may be present as a thin metal film or as a metal film thermally treated, to form metal island arrays, for example by vacuum or inert gas annealing between 200°C and 800°C. Alternatively, such metal film may be etched chemically or by plasma treatment, preferably plasma etched in an NH₃ plasma between 2-20 minutes. The metal particle size of such island arrays, preferably nickel island arrays is preferably of the order 2 to 100 nm.

It will also be apparent to a skilled person that various process pressures, gas flows & concentrations, and D.C. bias may be used during the plasma-striking stage and the deposition stage of this CNT production method.

CLAIMS

1. A method of forming carbon nanotubes by plasma enhanced chemical vapour deposition using a carbon containing gas plasma, wherein
5 the carbon nanotubes are not formed on a substrate at a temperature 300°C or above.
2. A method according to claim 1 wherein the substrate is not separately heated.
10
3. A method according to claim 2 wherein the substrate is kept at a temperature below 300°C.
4. A method according to claim 3 wherein the substrate is kept at
15 a temperature of 200°C or below.
5. A method according to claim 4 wherein the substrate is kept at a temperature of 150°C or below.
- 20 6. A method according to claim 5 wherein the substrate is kept at a temperature of 100°C or below.

7. A method according to claim 6 wherein the substrate is kept at a temperature of 50°C or below.

8. A method according to claim 7 wherein the substrate is kept at substantially room temperature.

9. A method according to claim 1 further comprising the step of cooling the substrate.

10. A method according to claim 9 wherein the substrate is kept at a temperature below 0°C.

11. A method according to claim 9 further comprising the step of cooling the substrate with liquid nitrogen.

15

12. A method according to any preceding claim further comprising the step of growing carbon nanotubes within a chamber on a substrate that is placed within the chamber.

20

13. A method according to claim 12 further comprising the step of placing a catalyst on a surface of the substrate.

14. A method according to any preceding claim wherein the substrate is placed on an earthed electrode of a plasma generator, within the sheathed region of the plasma.

5 15. A method according to claim 14 wherein the potential difference between the substrate/catalyst and the plasma is less than 100 volts.

16. A method according to claim 15 wherein the potential difference between the material/catalyst and the plasma is less than 70 volts.

10

17. A method according to claim 16 wherein the potential difference between the material/catalyst and the plasma is less than 40 volts.

18. A method according to any preceding claim effected within a plasma chamber further comprising the step of cooling the electrodes.

15

19. A method according to claim 18 wherein the electrodes are cooled by water.

20

20. A method according to claim 1 further comprising the step of growing the carbon nanotubes within a chamber and then depositing the carbon nanotubes on a substrate that is external to the chamber.

21. A method according to claim 20 further comprising the step of injecting a catalyst into the chamber.

5 22. A method according to claims 13 or 21 wherein the catalyst is a metal.

23. A method according to claim 22 wherein the metal is a transition metal.

10 24. A method according to claim 23 wherein the transition metal includes a metal, or mixture of metals, from the group comprising nickel (Ni), cobalt (Co) and iron (Fe).

15 25. A method according to claim 21 wherein the catalyst is in the form of a powder.

26. A method according to claim 13 wherein the catalyst is in the form of a powder, film or island arrays.

20 27. A method according to claim 26 wherein the island arrays are etched island arrays of which the particle size is between 2nm and 100nm.

28. A method according to claim 25 or 26 wherein the powder has a particle size from 1 μ m to 10 μ m.

5 29. A method according to any preceding claim wherein the substrate is of organic material.

30. A method according to any of claims 1 to 29 wherein the substrate is a fabric.

10 31. A method according to any of claims 1 to 30 wherein the substrate is a plastics material.

32. A method according to any of claims 1 to 30 wherein the substrate is a polymer.

15 33. A method according to any of claims 1 to 29 wherein the substrate is paper.

20 34. A method according to any preceding claim wherein the plasma is of an ionised gas or gas mixture.

35. A method according to any preceding claim wherein the plasma is in the form of a beam.

36. A method according to any preceding claim wherein the plasma is generated by radio-frequency energy.

5 37. A method according to any preceding claim wherein the plasma is generated by radio-frequency energy combined with microwave energy.

10 38. A method according to any of claims 1 to 35 wherein the plasma is generated by microwave energy.

39. A method according to any of claims 1 to 35 wherein the plasma is generated using a pulsed power supply.

15 40. A method according to any preceding claim wherein the plasma is generated by a primary power source and combined with at least one secondary power source.

20 41. A method according to any preceding claim wherein the carbon containing gas is a hydrocarbon gas.

42. A method according to claim 41 wherein the hydrocarbon gas is methane, acetylene, ethylene or any mixture of the said gases.

43. A method according to any of claims 1 to 40 wherein the carbon containing gas is carbon monoxide or carbon dioxide.

5 44. A method according to any of claims 1 to 40 wherein the carbon containing gas is non-destructive and non-etching of the substrate or chamber when in a plasma state.

10 45. A method according to any preceding claim wherein the carbon containing gas is combined with a carrier gas.

46. A method according to claim 45 wherein the carrier gas is from the group comprising nitrogen, hydrogen, argon and ammonia.

15 47. A method according to any preceding claim further comprising the step of performing the method in a vacuum chamber constructed to generate, maintain and withstand a gaseous plasma.

20 48. A method according to any preceding claim further comprising the step of inserting the carbon nanotubes into a liquid which will cause them to self-organise into ropes.

49. A method according to claim 48 wherein the liquid is water.

50. A method according to any of claims 1 to 47 subsequently followed by an acid treatment step for removal of excess catalyst particles.

5 51. A method according to claim 50 subsequently followed by a wash step to remove the acid.

52. A method according to any preceding claim, wherein a proportion of formed nanotubes are in at least one of the following forms: bi-
10 directional, branched, multiple-coaxial, coiled or densely packed ropes of nanotubes.

53. A carbon nanotube formed by a method according to claim 52 wherein the carbon nanotube comprises a substantially Y-shaped junction.

15

54. A carbon nanotube formed by a method according to claim 52 wherein the carbon nanotube comprises a substantially H-shaped junction.

55. A rope of carbon nanotubes obtained by a method according to
20 claim 52.

56. A method of providing a pattern of carbon nanotubes on a fabric or organic material.

57. A method of forming ropes of partially aligned carbon nanotubes, comprising placing said nanotubes in a liquid selected so that the nanotubes self-organise into bundles.

5

58. A method according to claim 57, in which said liquid comprises water.

1/9

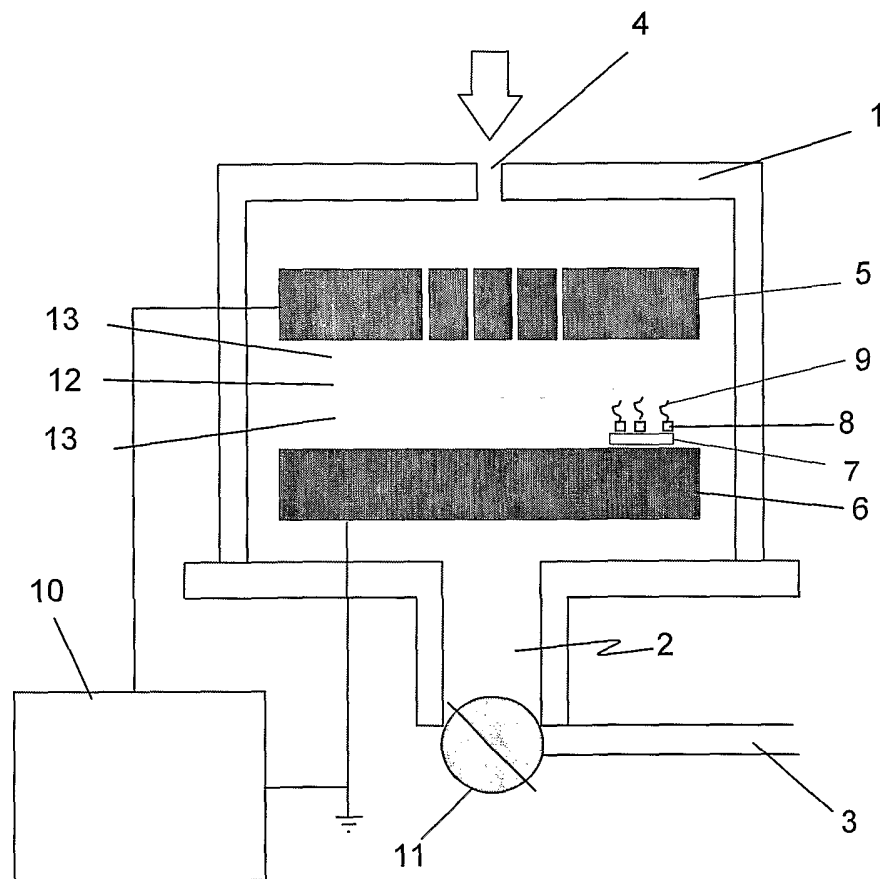

Figure 1

2/9

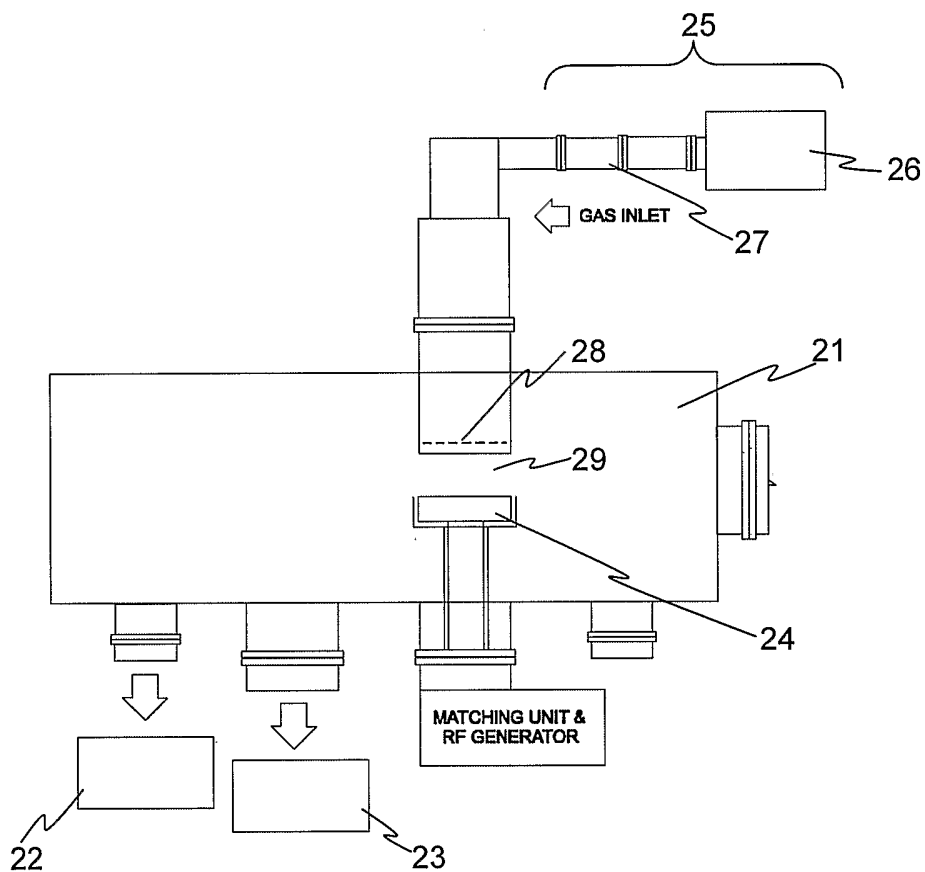

Figure 2

3/9

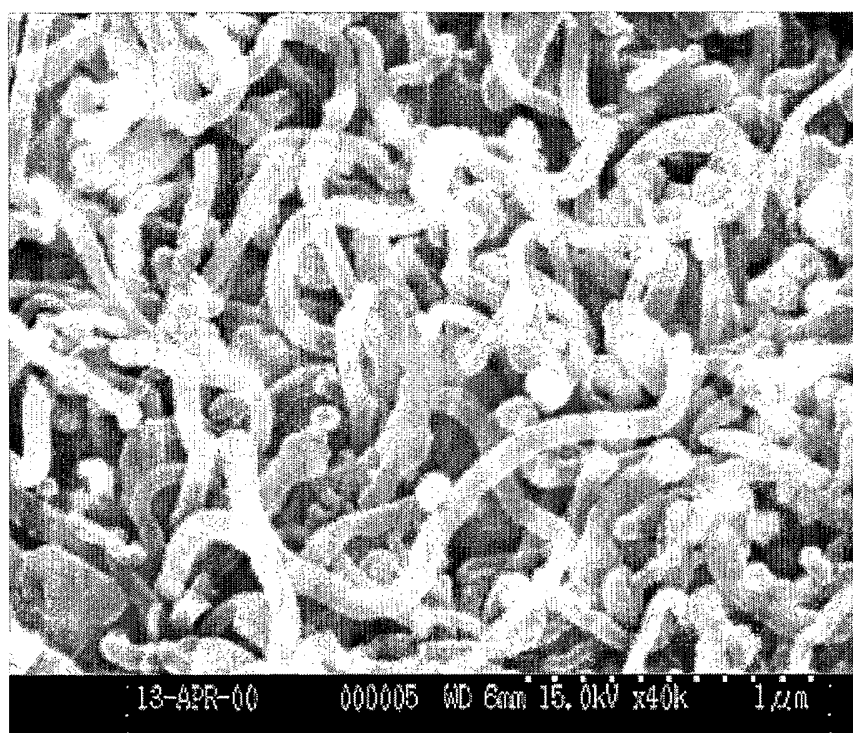
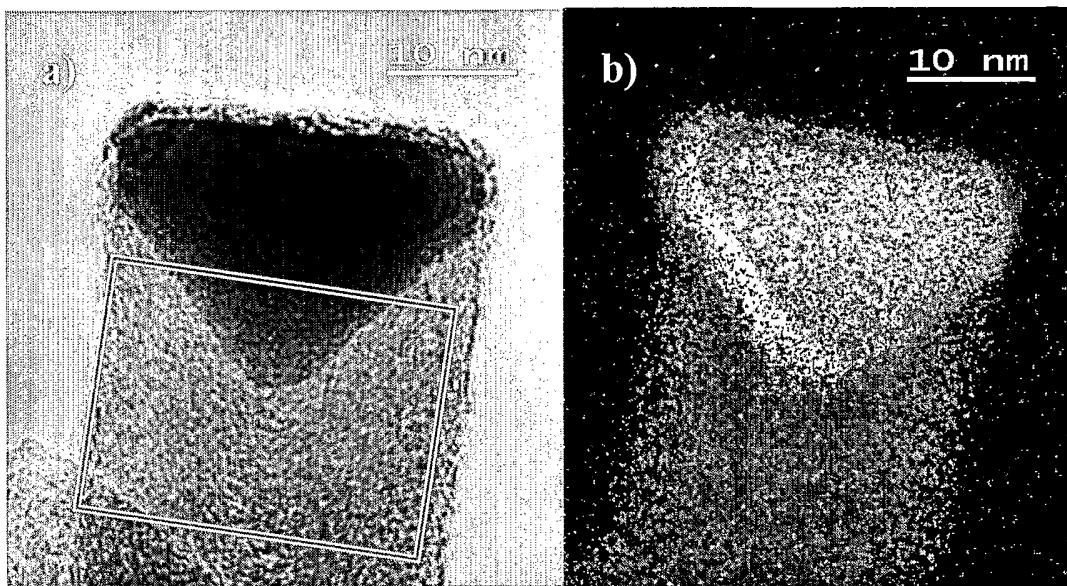

Figure 3

4/9



4A

4B

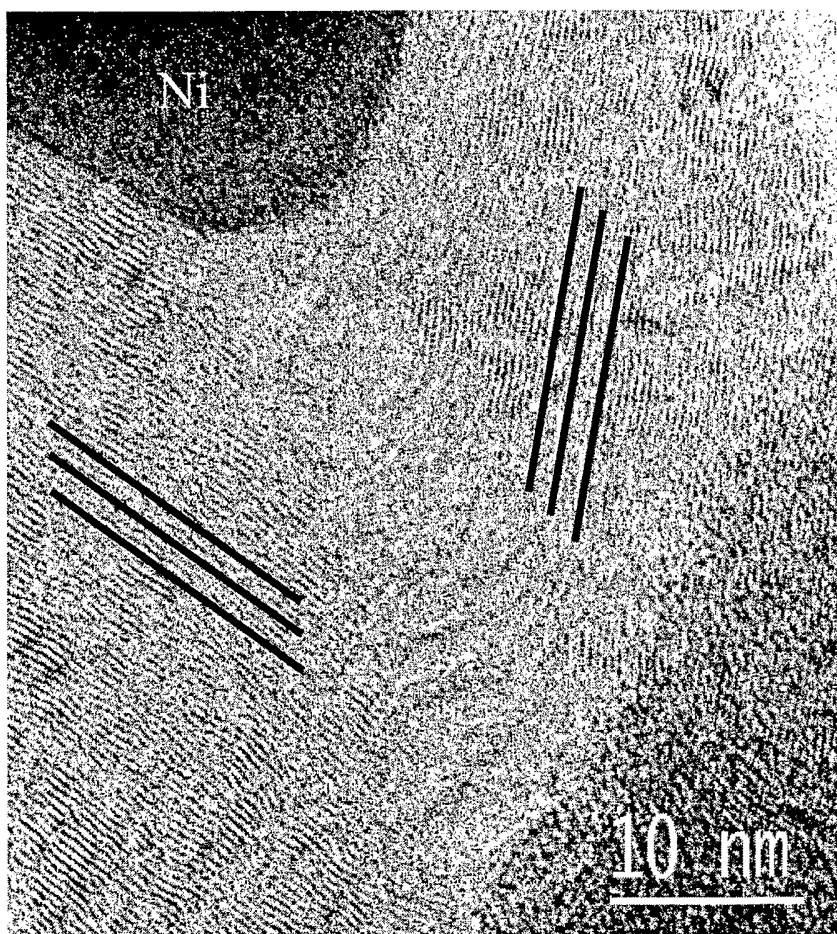

4C

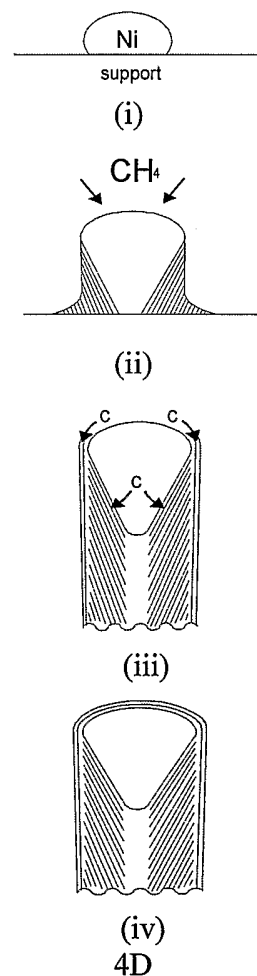

(iv)
4D

Figure 4

5/9

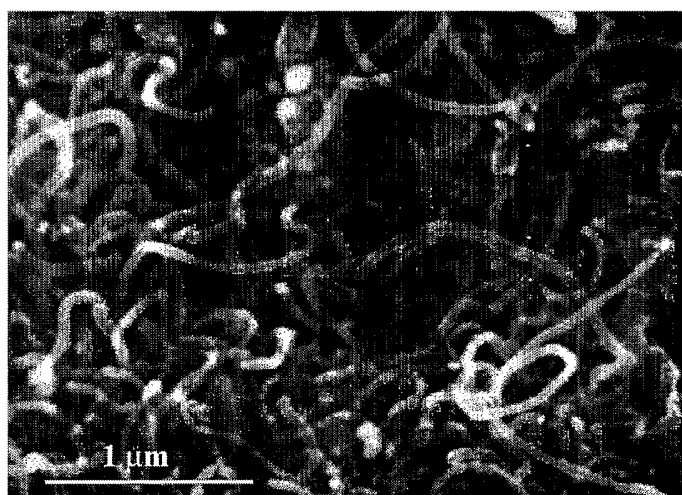

5A

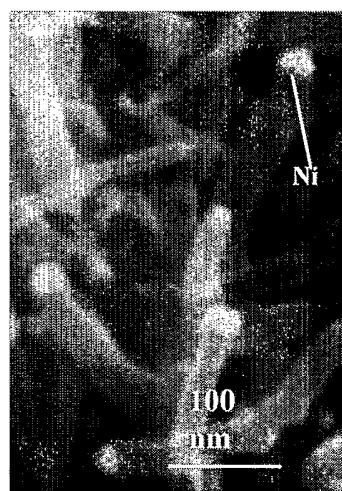

5B

Figure 5

6/9

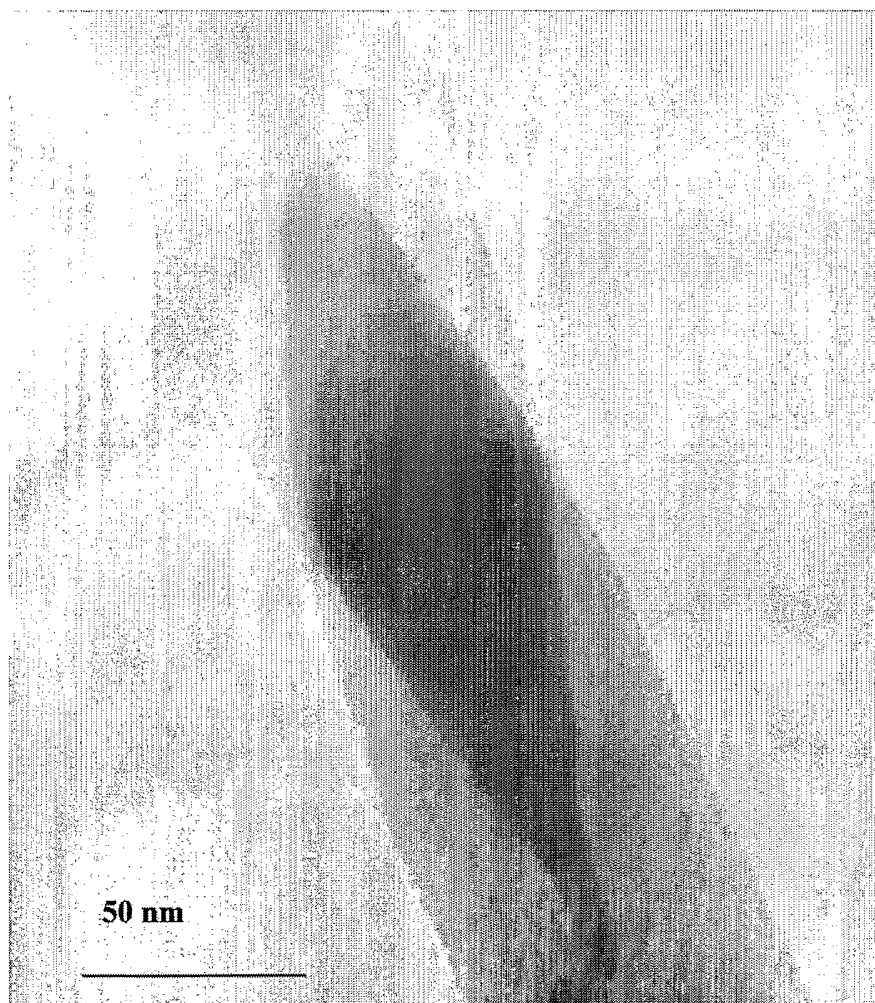
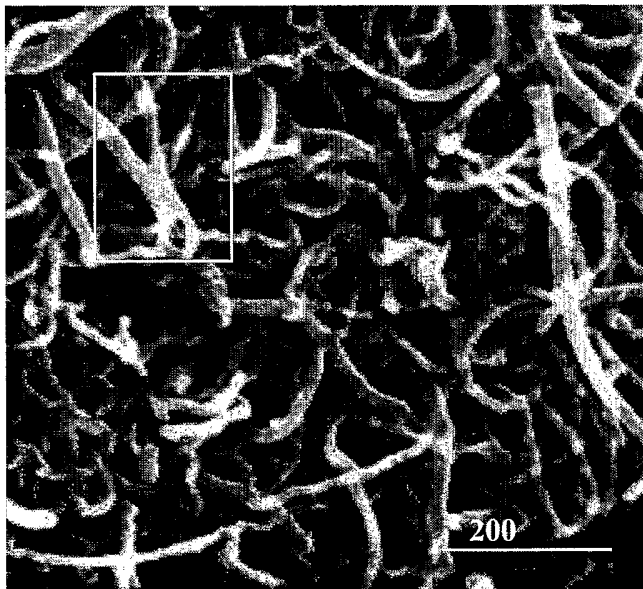

Figure 6

7/9



7A



7B

Figure 7

8/9

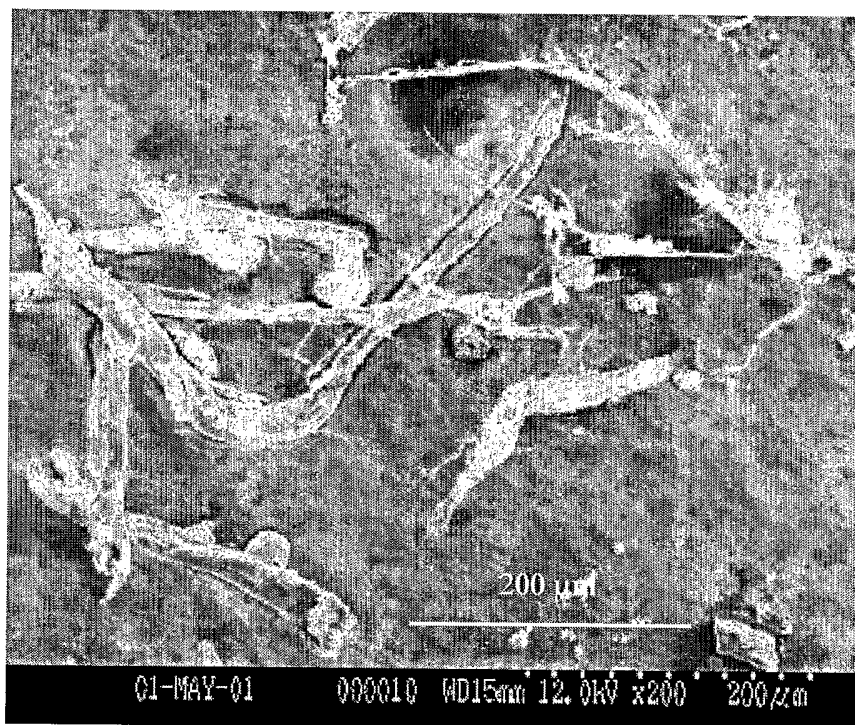

Figure 8

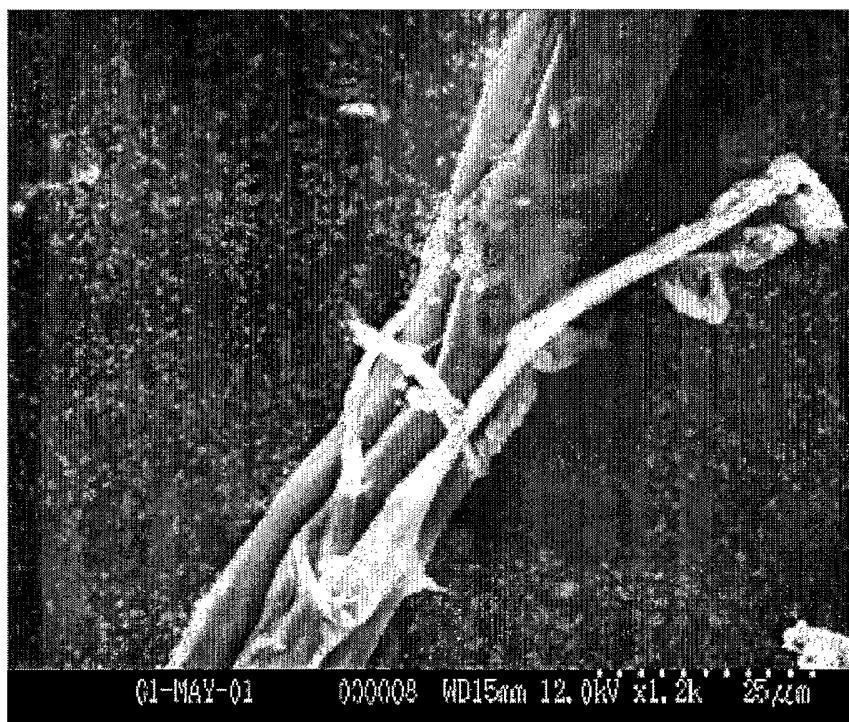

Figure 9

INTERNATIONAL SEARCH REPORT

International Application No
PCT/GB 02/03438

A. CLASSIFICATION OF SUBJECT MATTER
IPC 7 C01B31/02

According to International Patent Classification (IPC) or to both national classification and IPC

B. FIELDS SEARCHED

Minimum documentation searched (classification system followed by classification symbols)
IPC 7 C01B

Documentation searched other than minimum documentation to the extent that such documents are included in the fields searched

Electronic data base consulted during the international search (name of data base and, where practical, search terms used)
WPI Data, PAJ, INSPEC, COMPENDEX, CHEM ABS Data, EPO-Internal

C. DOCUMENTS CONSIDERED TO BE RELEVANT

Category °	Citation of document, with indication, where appropriate, of the relevant passages	Relevant to claim No.
X	SHOW Y ET AL: "Formation of carbon nanotube by using RF plasma CVD equipment from acetylene and hydrogen gases" NANOTUBES AND RELATED MATERIALS; BOSTON, MA, UNITED STATES, vol. 633, 27 November 2000 (2000-11-27), pages A13121-A13126, XP008010715 Materials Research Society Symposium - Proceedings 2001 the whole document	1-6, 12, 13, 22-24, 26, 34, 36, 41, 42, 44-46, 52, 55
Y	---	48-51
A	-/--	7, 8, 14-19

Further documents are listed in the continuation of box C. Patent family members are listed in annex.

° Special categories of cited documents :

A document defining the general state of the art which is not considered to be of particular relevance	*T* later document published after the international filing date or priority date and not in conflict with the application but cited to understand the principle or theory underlying the invention
E earlier document but published on or after the international filing date	*X* document of particular relevance; the claimed invention cannot be considered novel or cannot be considered to involve an inventive step when the document is taken alone
L document which may throw doubts on priority claim(s) or which is cited to establish the publication date of another citation or other special reason (as specified)	*Y* document of particular relevance; the claimed invention cannot be considered to involve an inventive step when the document is combined with one or more other such documents, such combination being obvious to a person skilled in the art.
O document referring to an oral disclosure, use, exhibition or other means	* & * document member of the same patent family
P document published prior to the international filing date but later than the priority date claimed	

Date of the actual completion of the international search 6 December 2002	Date of mailing of the international search report 20/12/2002
---	---

Name and mailing address of the ISA European Patent Office, P.B. 5818 Patentlaan 2 NL - 2280 HV Rijswijk Tel. (+31-70) 340-2040, Tx. 31 651 epo nl, Fax: (+31-70) 340-3016	Authorized officer Rigondaud, B
--	---

INTERNATIONAL SEARCH REPORT

International Application No

PCT/GB 02/03438

C.(Continuation) DOCUMENTS CONSIDERED TO BE RELEVANT		
Category °	Citation of document, with indication, where appropriate, of the relevant passages	Relevant to claim No.
Y	COLOMER J-F ET AL: "PURIFICATION OF CATALYTICALLY PRODUCED MULTI-WALL NANOTUBES" JOURNAL OF THE CHEMICAL SOCIETY. FARADAY TRANSACTIONS, ROYAL SOCIETY OF CHEMISTRY, CAMBRIDGE, GB, vol. 94, no. 24, 21 December 1998 (1998-12-21), pages 3753-3758, XP000799754 ISSN: 0956-5000 the whole document	50,51
X	VIGOLO B ET AL: "Macroscopic fibers and ribbons of oriented carbon nanotubes" SCIENCE, 17 NOV. 2000, AMERICAN ASSOC. ADV. SCI, USA, vol. 290, no. 5495, pages 1331-1334, XP008004074 ISSN: 0036-8075 the whole document	57,58
Y	---	48,49
X	JAE-HOON JUNG ET AL: "Preparation of carbon nanotubes on Ni/Fe alloy substrate and their application" IDW '00. PROCEEDINGS OF THE SEVENTH INTERNATIONAL DISPLAY WORKSHOPS, PROCEEDINGS OF 7TH INTERNATIONAL DISPLAY WORKSHOPS - IDW'00, KOBE, JAPAN, 29 NOV.-1 DEC. 2000, pages 1023-1026, XP008010846 USA the whole document	1-8,12, 13, 22-25, 34,38, 41,42, 44-46, 52,55
P,X	KUMAR S ET AL: "Realization of different carbon nanostructures by a microwave plasma enhanced chemical vapor deposition technique" APPL SURF SCI;APPLIED SURFACE SCIENCE OCT 22 2001, vol. 182, no. 3-4, 22 October 2001 (2001-10-22), pages 326-332, XP002223797 the whole document	1-8,12, 34,38, 41,42, 44,46, 52,55
P,X	SANO M ET AL: "Self-organization of PEO-graft-single-walled carbon nanotubes in solutions and Langmuir-Blodgett films" LANGMUIR, 21 AUG. 2001, AMERICAN CHEM. SOC, USA, vol. 17, no. 17, pages 5125-5128, XP002223799 ISSN: 0743-7463 the whole document	57,58

	-/--	

INTERNATIONAL SEARCH REPORT

In International Application No
PCT/GB 02/03438

C.(Continuation) DOCUMENTS CONSIDERED TO BE RELEVANT		
Category °	Citation of document, with indication, where appropriate, of the relevant passages	Relevant to claim No.
A	<p>WANG X ET AL: "Synthesis of multi-walled carbon nanotubes by microwave plasma-enhanced chemical vapor deposition" THIN SOLID FILMS, ELSEVIER-SEQUOIA S.A. LAUSANNE, CH, vol. 390, no. 1-2, 30 June 2001 (2001-06-30), pages 130-133, XP004246662 ISSN: 0040-6090 the whole document</p> <p style="text-align: center;">----</p>	<p>1,21-24, 26,30, 38,41, 45-47,52</p>
A	<p>EBBESEN THOMAS W:: "Production and purification of carbon nanotubes" HANDBOOK OF APPLIED CRYPTOGRAPHY, CRC PRESS SERIES ON DISCRETE MATHEMATICS AND ITS APPLICATIONS, BOCA RATON, FL, CRC PRESS, US, 1997, pages 154-159, XP002148445 ISBN: 0-8493-8523-7 the whole document</p> <p style="text-align: center;">-----</p>	<p>50-52</p>

INTERNATIONAL SEARCH REPORT

International Application No
 FU/GB 02/03438

Patent document cited in search report	Publication date	Patent family member(s)	Publication date
KR 2001057162	A	NONE	
EP 1190987	A	27-03-2002	CN 1345694 A
			24-04-2002
			EP 1190987 A1
			27-03-2002
			JP 2002121015 A
			23-04-2002
			US 2002127170 A1
			12-09-2002