

(19) (12) (KR) (A)

(51) 。 Int. Cl.7

B23P 15/28

B23B 27/14

B23C 5/20

(11)

(43)

10-2004-0102009

2004 12 03

(21) 10-2004-7012940

(22) 2004 08 19

2004 08 19

(86) PCT/IB2003/000599

(87)

WO 2003/070416

(86) 2003 02 20

(87)

2003 08 28

(30) 2002/1473

2002 02 21

(ZA)

(71) ()

1559

(72) 2144

6

2193

7 가

11

2194

50

1724

10

12

-915 32

28

-918 94

121

-915 92

34

-906 55

53

(74)

:

(54)

(50)가

PCBN PCD
(58)

(68)

(56)

가

가

가

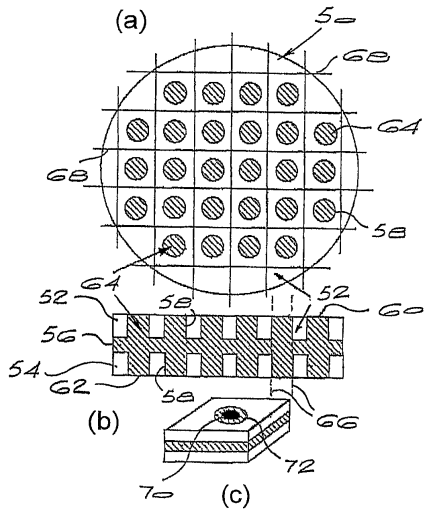

(tool insert)

(abrasive compact)

PCD

(cemented carbide)

PCBN

4,807,402

0 714 719

1 2

4,807,402

가

가 , PCD PCBN , PCBN 가 .

100mm 가 , 1.6mm 30mm, 55mm 125mm, 2mm 10mm 80mm .

가

가

, 60 가

3

가

1 (a) , (b) (a) , (c)

2 8 , (c) , (a) , (b)

1 가 (10) 1 (a) (12) , (12) (14) (rod) (16) (18)

(10) (20) (18)가 (14) (16) (22) (24)가 (26) (22)

(10) / / 가 , 1 (a) (b) 가 가

2 1 가 가 , 2 (c) 가

3 1 가 가 , 3 (c) (菱面體) 가

4 4 (c) 1 , 90 가 , 4 (30) (32) , 4 가 (20a, 20b) (21a, 21b) (28) (32) (34)

5 (10) 1 5 (c) (18) 5 (a) (20)
 3 (40) (36) (42) 60 가 (40)
 6 (60, 62) (64) (50) (58)가 (56) (58) (52, 54) 가 (60)
 (62) (66) (50) (56) (68) 6 (c)
 가 (72) (70)
 7 (58) 6 가 7 (c)
 가 (68)
 8 (68) 6 8 (c) 가 (58)
 4 5 가 6 (66) (68)
 가

(57)

1. (tool insert) , (superabrasive) ,

1 2. (abrasive compact)

2 3. PCD PCBN

1 4. 3 ,

(cemented carbide),

1 5. 4

5 6.

55mm 125mm , 1.6mm 30mm

6 7.

80mm 100mm , 2mm 10mm

1 8. 7

1 9. 8

10.

10 11.

10 12.

13.

12

60 가

3

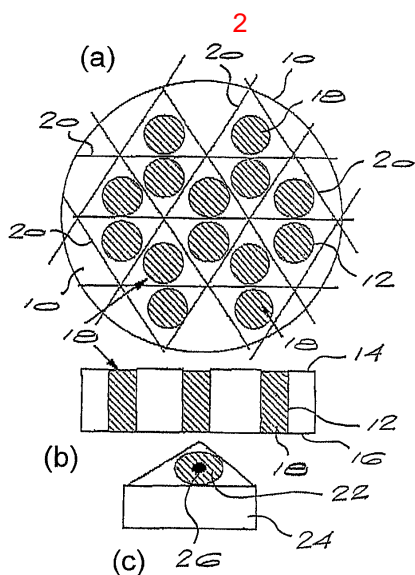
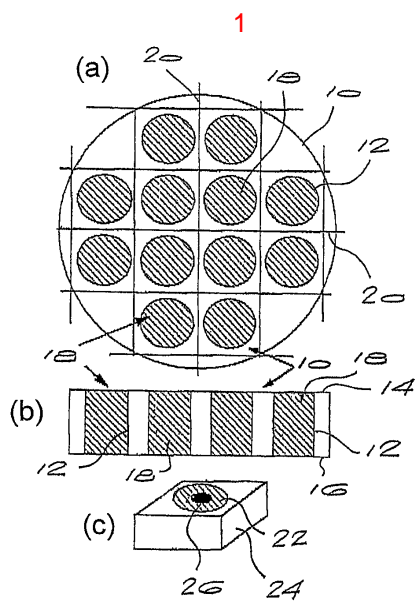

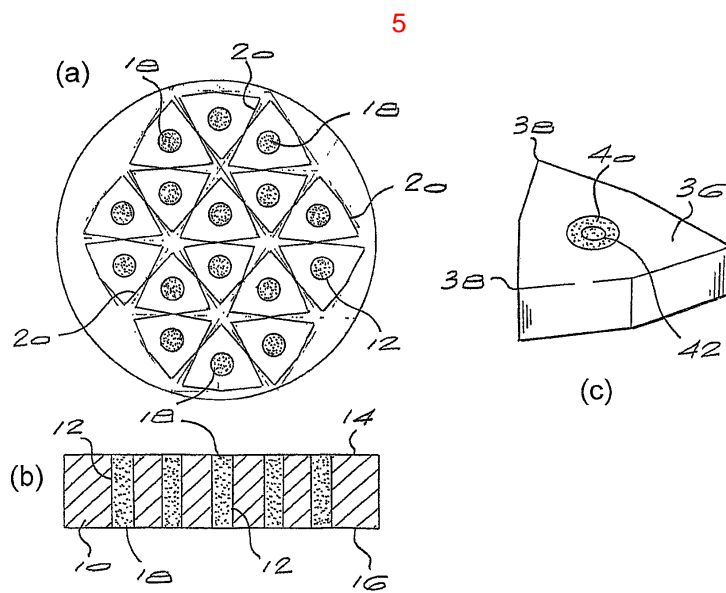
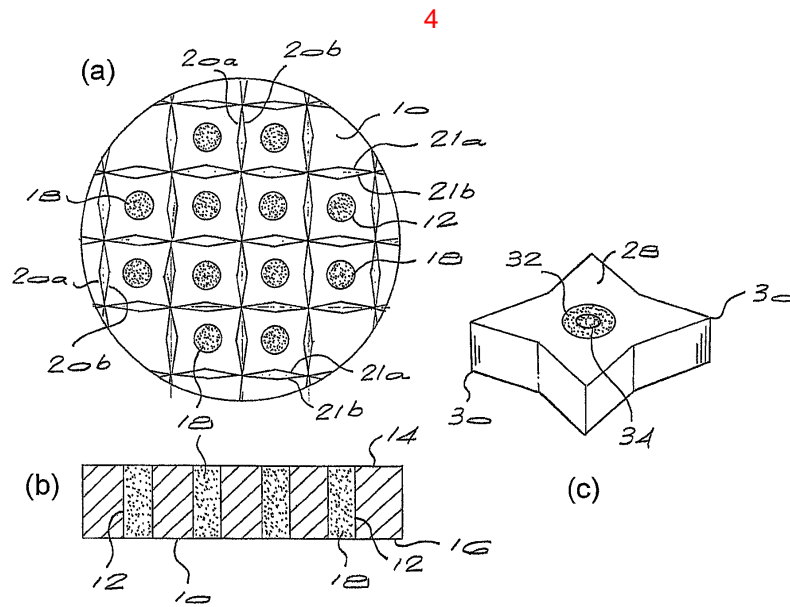
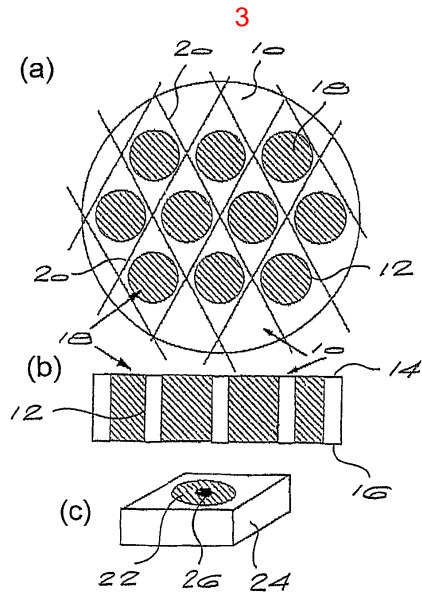

6

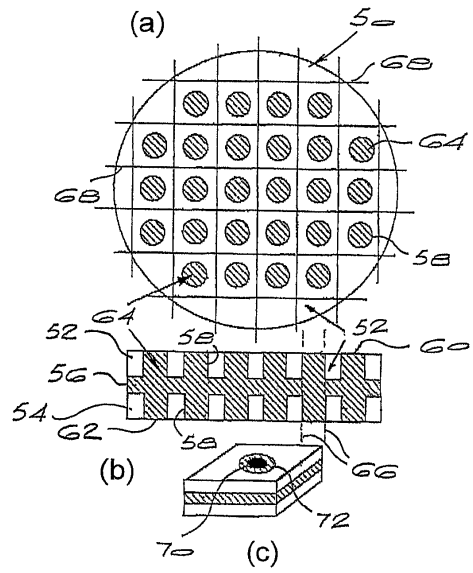

7

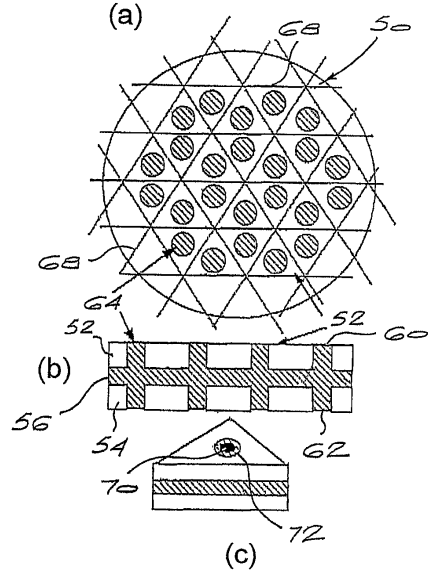

8

