



(11) **EP 2 098 457 A1**

(12) **EUROPEAN PATENT APPLICATION**

(43) Date of publication:
09.09.2009 Bulletin 2009/37

(51) Int Cl.:
B65D 21/02^(2006.01) B65D 45/22^(2006.01)

(21) Application number: **09152678.0**

(22) Date of filing: **12.02.2009**

(84) Designated Contracting States:
AT BE BG CH CY CZ DE DK EE ES FI FR GB GR HR HU IE IS IT LI LT LU LV MC MK MT NL NO PL PT RO SE SI SK TR
 Designated Extension States:
AL BA RS

(71) Applicant: **Lock & Lock Co., Ltd. Asan, Chungnam (KR)**

(72) Inventor: **Kim, Chang Ho Seoul (KR)**

(74) Representative: **Capasso, Olga et al De Simone & Partners S.p.A. Via Vincenzo Bellini, 20 00198 Roma (IT)**

(30) Priority: **07.03.2008 KR 20080021396**

(54) **Interlocking container**

(57) The present invention relates to an interlocking container (100) that has a wing (130) provided on the exterior wall of a container body (110) containing contents and fixes the other container body interlocked above the container body by means of the wing. The interlocking container includes a container body that includes a projecting portion (115) bent downward, which is provided at the circumference of an exterior wall, a first groove (116) grooved at an upper end of the projecting portion in a predetermined depth, and a hill portion (117)

that is provided at an entrance of the first groove and projects from an upper end of the projecting portion; a wing that includes a pair of hinges (113) projecting at one side of the exterior wall, a support body (133) hinge-coupled with the hinge, and a fixation projecting piece (135) projecting on one end of the support body to form a predetermined angle to the support body, which fits in the first groove through the fixation projecting piece; and a cover (150) that includes the projecting portion (115) and the hill portion (117).

[FIG. 5]

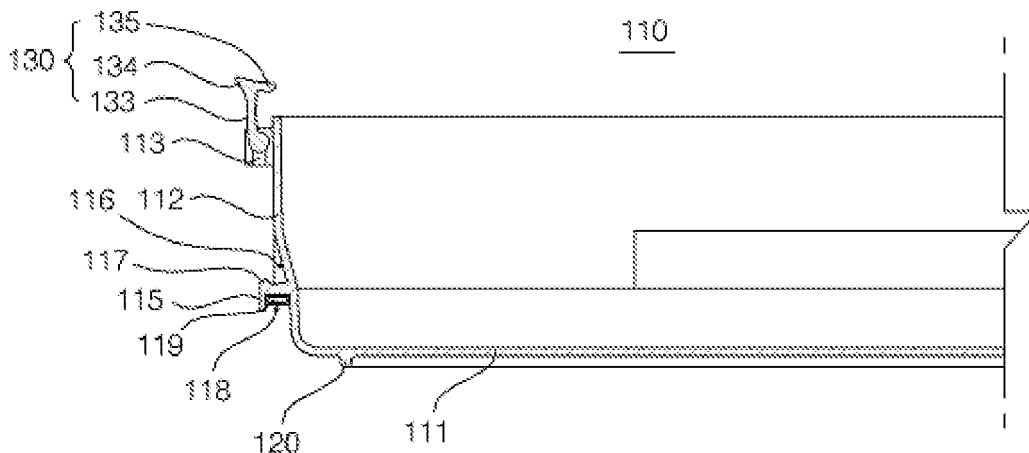

EP 2 098 457 A1

Description

BACKGROUND OF THE INVENTION

1. Technical Field

[0001] The present invention relates to an interlocking container. More particularly, the present invention relates to an interlocking container that has a wing provided on the exterior wall of a container body containing contents and fixes the other container body interlocked above the container body by means of the wing.

2. Related Art

[0002] In general, a container body containing food is molded by synthetic resin, heat-resistant glass, heat-resistant ceramics, etc. which are materials permitted for food storage. Among them, the product molded by the synthetic resin can be mass-produced, is low-priced, and is convenient to handle, as a result the product molded by the synthetic resin is most widely used. Locking devices are provided in a main body and a cover of the container in order to safely keep and store food stored in an airtight container and prevent the food from being leaked.

[0003] A plurality of suspension projections projecting outward from an edge of the container body are formed in the container body at predetermined intervals in a circumferential direction. Locking wings which are rotatable up and down around a hinge are formed in the cover and coupling holes into which the suspension projections of the container body are inserted are formed in the locking wings. In the container, the suspension projections are elastically inserted into and coupled to the coupling holes of the locking wing by rotating and pressing each of the locking wings to the container body in a state in which an opening of the container body is covered with the cover. However, since the coupling holes of the locking wings are not completely coupled with the suspension projections of the container body, fastening force between the containers is loose, which results in the stored contents frequently being discharged to the outside in the known container.

[0004] In addition, it is very difficult to form the known container in multiple layers. As less people eat at home and the size of the family decreases, various foods are cooked in smaller portions more frequently than cooking one type of food in a large amount at home. Therefore, the number of kinds of the stored food increases. In this case, several containers are required rather than the container's own size. However, in the case when several containers are used, several containers occupy too much space inside of a refrigerator. As a result, a multi-layered container in which several container bodies can be interlocked while only one cover is used is required. However, in the case when the container is molded to interlock the containers in multiple layers, a packing must be disposed

on each of the container bodies in addition to the cover in order to improve airtightness of each container body. The multi-layered container must have a structure in which the packing can be disposed on the cover and each container body. However, the known container does not have such a structure.

SUMMARY OF THE INVENTION

[0005] The present invention is contrived to solve the above-mentioned problems. An object of the present invention is to provide an interlocking container that has grooves grooved at a projecting portion in a predetermined depth through the projecting portion formed on the exterior wall of a container body and a hill portion for closing a part of each of the grooves in the container body and fixation projecting pieces that are inserted into the grooves and are suspended by the hill portion to prevent food from being leaked in a wing.

[0006] Further, another object of the present invention is to provide an interlocking container that considers the aesthetics by disposing a packing in the projecting portion of the container body and the grooves formed on the exterior wall of the container body.

[0007] The present invention is contrived to achieve the above-mentioned objects. There is provided an interlocking container that includes a container body that includes a projecting portion bent downward, which is provided at the circumference of an exterior wall, a first groove grooved at an upper end of the projecting portion in a predetermined depth, and a hill portion that is provided at an entrance of the first groove and projects from an upper end of the projecting portion; a wing that includes a pair of hinges projecting at one side of the exterior wall, a support body hinge-coupled with the hinge, and a fixation projecting piece projecting on one end of the support body to form a predetermined angle to the support body, which fits in the first groove through the fixation projecting piece; and a cover that includes the projecting portion provided at the circumference of the exterior wall and the hill portion provided on the top surface of the projecting portion, which covers the upper part of the container body.

[0008] Preferably, the container body has a flexible packing provided in a second groove that is formed by the exterior wall and the projecting portion.

[0009] Preferably, the wing further includes a handle provided on one surface of the support body and the container body further includes a joining fixation portion that connects the hinge formed on one surface of the container body with the hinge formed on the other surface of the container body in order to fix the container body.

[0010] Preferably, the interlocking container is molded by a plastic material and is transparent.

[0011] Preferably, the cover includes a grippable handle mounted on the top surface thereof.

[0012] The present invention takes the following effects in accordance with the above-mentioned configura-

ration. First, it is possible to remarkably improve a fastening force between containers interlocked through grooves formed in a container body and a fixation projecting pieces formed in a wing. It is possible to increase a lifespan of the interlocking container by preventing movement of the interlocking container and preventing a wearing phenomenon generated due to friction between the containers through inserting a packing into a gap between the exterior wall and the projecting portion.

BRIEF DESCRIPTION OF THE DRAWINGS

[0013]

FIG. 1 is a perspective view of an interlocking container according to an embodiment of the present invention;

FIG. 2 is an exploded perspective view of an interlocking container according to an embodiment of the present invention;

FIG. 3 is an enlarged view of a major part in a state before one surface of an interlocking container is joined according to an embodiment of the present invention;

FIG. 4 is an enlarged view of a major part in a state after one surface of an interlocking container is joined according to an embodiment of the present invention;

FIG. 5 is a cross-sectional view of a container body shown in FIG. 2 taken along the line A-A' according to an embodiment of the present invention;

FIG. 6 is a cross-sectional view of a cover shown in FIG. 2 taken along the line B-B' according to an embodiment of the present invention; and

FIG. 7 is a perspective view of an interlocking container according to another embodiment of the present invention.

DESCRIPTION OF THE PREFERRED EMBODIMENTS

[0014] Hereinafter, preferred embodiments of the present invention will be described in detail with reference to the accompanying drawings. First of all, we should note that in giving reference numerals to elements of each drawing, like reference numerals refer to like elements even though like elements are shown in different drawings. Further, in describing the present invention, well-known functions or constructions will not be described in detail since they may unnecessarily obscure the understanding of the present invention. Hereinafter, the preferred embodiment of the present invention will be described, but it will be understood to those skilled in the art that the spirit and scope of the present invention are not limited thereto and various modifications and changes can be made.

[0015] FIG. 1 is a perspective view of an interlocking container according to an embodiment of the present invention. FIG. 2 is an exploded perspective view of an

interlocking container according to an embodiment of the present invention. FIG. 3 is an enlarged view of a major part in a state before one surface of an interlocking container is joined according to an embodiment of the present invention. FIG. 4 is an enlarged view of a major part in a state after one surface of an interlocking container is joined according to an embodiment of the present invention. FIG. 5 is a cross-sectional view of a container body shown in FIG. 2 taken along the line A-A' according to an embodiment of the present invention. FIG. 6 is a cross-sectional view of a cover shown in FIG. 2 taken along the line B-B' according to an embodiment of the present invention. Hereinafter, an interlocking container according to an embodiment of the present invention will be described with reference to FIGS. 1 to 6.

[0016] As shown in FIGS. 1 and 2, the interlocking container 100 according to an embodiment of the present invention includes a container body 110, a wing 130, and a cover 150.

[0017] The container body 110 has a tub shape and is formed in a structure in which walls 113 are integrally provided at a circumference end of a top surface of a bottom 111. Therefore, the container body 110 has a space having a predetermined size so as to store contents therein. Inner and outer edges of the container body 110 are preferably curved by considering aesthetic.

[0018] The container body 110 has a pair of hinges 113 disposed at exterior upper ends of sides thereof and is hinge-coupled with the wing 130 through the hinge 113. Further, the container body 110 has joining fixation portions 114, such that the hinges 113 are not easily broken even due to a small external shock. The joining fixation portions 114 projects in a predetermined thickness so as to interconnect the hinges 113 projecting on one surface and the other surface thereof.

[0019] The container body 110 has a projecting portion 115 bent downward, which is formed on an exterior lower periphery thereof. Referring to FIGS. 3 and 4, the container body 110 has first grooves 116 of a right triangle formed above the projecting portion 115 and the container body 110 fits in the wing 130 disposed in the other container body through the first grooves 116. FIG. 3 illustrates a state before the wing 130 is fitted into the first grooves 116 and FIG. 4 illustrates a state after the wing 130 is fitted into the first grooves 116.

[0020] The container body 110 has a hill portion 117 that projects from the top surface of the projecting portion 115 and closes a part of each of the first grooves 116, which are formed at entrances of the first grooves 116 so as to further improve fit-coupling force with the wing 130. In this case, the hill portion 117 preferably has a triangle pole shape or a semicircular pole shape, such that the wing 130 can easily slide to the first grooves 116. Meanwhile, the first grooves 116 are not limited to the right triangle shape, but the first grooves 116 may have a general triangle shape or a semicircular shape. Further, it is apparent that each first groove 116 has a size equal to a length of each fit-in wing 130.

[0021] The container body 110 has second grooves 118 grooved upward, which are formed below the first grooves 116 by the projecting portion 115. Hereinafter, refer to FIG. 5. In the embodiment of the present invention, the second grooves 118 allows the container body to be coupled with an upper end of the other container body and secures the coupling force between the container bodies altogether with the first grooves 116. The second grooves 118 may include a packing 119 filled up therein.

[0022] In the embodiment of the present invention, the packing 119 serves to remove the movability while increasing airtightness between the container bodies. The packing 119 is preferably made of a rubber material having flexibility so as to prevent the lifespan of the second groove 118 from being shortened due to wearing of the second groove 118, which may be generated by frequent fitting therein.

[0023] Meanwhile, the container body 110 also includes a bottom protrusion 120 protruding downward from a bottom surface of the bottom 111. The bottom protrusion 120 is preferably formed on one periphery by considering easy standing of the container body 110. When the container body 110 includes the bottom protrusion 120, it is possible to prevent the entire bottom surface of the bottom 111 from being dirty due to outside wastes and when the container body 110 comes in contact with a cold material, etc., it is possible to prevent inner heat from being discharged through the bottom 111.

[0024] As described above, the wing 130 is hinge-coupled with the pair of hinges 113 formed on one surface of the container body 110. More specifically, the wing 130 is hinge-coupled with the hinges 113 by inserting protrusions formed at both ends of the wing 130 into grooves of the hinges 113. Hereinafter, referring to FIGS. 1 to 5, the wing 130 coupled to the container body 110 will be described over all. First, a role and a disposing structure of the wing 130 are described. Thereafter, a shape of the wing 130 is described. The shape of the wing 130 is clearly shown in FIGS. 3 to 5. Therefore, it is preferable to refer to FIGS. 3 to 5 for description of the shape of the wing 130.

[0025] The wing 130 serves to fix the other container body interlocked on the container body 110 in the embodiment of the present invention. Therefore, although the wing 130 is preferably provided on each side of the container body 110, the embodiment of the present invention needs not to be limited thereto. This reason is that the wing 130 can sufficiently carry out the fixing role even by disposing the wings 130 at both sides of the container body 110, which face each other.

[0026] As shown in FIG. 2, by considering that the container body 110 has a substantially rectangular shape, four wing portions including two first wing portions 131 in a horizontal direction and two second wing portions 132 in a vertical direction are mounted in the container body 110 as the wing 130.

[0027] Next, the shape of the wing 130 will be de-

scribed. The wing 130 includes a support body 133, a handle 134, and a fixation projecting piece 135 in the embodiment of the present invention. The support body 133 is a body forming a background of the wing 130 and is supported on the container body 110 by protrusions that are disposed at both ends thereof. The support body 133 includes a handle 134 and the fixation projecting piece 135 that project in different directions at one end of the support body.

[0028] The handle 134 is used as a handle to allow a user to easily operate the wing 130 by means of user's hands. The handle 134 projects outwards. It is most preferable that the handle 134 projects upward in an outer diagonal direction by considering that the handle 134 may be easily broken due to a small external shock when the handle 134 excessively projects outwards, the handle 134 must be convenient to grip, while having an aesthetic appearance. Meanwhile, in the embodiment of the present invention, the handle 134 generally has a length equal to a length of the support body 133, but the length of the handle 134 is not necessarily limited thereto.

[0029] The fixation projecting piece 135 is directly inserted into the first groove 116 of the container body 110 in the wing 130 and projects in a direction opposite to the handle 134. The fixation projecting piece 135 preferably project in a perpendicular direction to the support body 133. This reason is that the movability of the other container body can be more efficiently removed by allowing the fixation projecting piece 135 to be closely contacted with the other container body in this case.

[0030] The fixation projecting piece 135 has a structure in which one end of a bottom surface projects downward in the embodiment of the present invention. By this structure, it is possible to prevent the fixation projecting piece 135 from being separated from the first groove 116 after being inserted into the first groove 116.

[0031] The cover 150 is used as a cover that closes an opened top part of the container body 110. In the embodiment of the present invention, the cover 150 has a projecting portion 115 bent downward, which is formed on a side periphery thereof, and includes the hill portion 117 above the projecting portion 115 and the second groove 118 and the packing 119 below the projecting portion 115. The projecting portion 115, the hill portion 117, the second groove 118, and the packing 119 have been already described above. Therefore, the detailed description thereof will be herein omitted.

[0032] As described above, the interlocking container 100 according to the embodiment of the present invention is realized by interlocking the plurality of container bodies 110. The container bodies 110 interlocked on each container body are fastened with each other by means of the wing 120 and an inner space of the uppermost container body 110 is closed by the cover 150, whereby the interlocking container 100 can perform as the container.

[0033] The interlocking container 100 is preferably made of a light-weight material such as a plastic material by considering portability in the embodiment of the

present invention. Further, the interlocking container 100 is preferably manufactured by a transparent material in order to observe the present state (i.e., deterioration or not) of the contents stored therein.

[0034] Meanwhile the interlocking container 100 preferably has a handle provided on the top surface of the cover 150 so as to be gripped for easy transport. Referring to FIG. 7, reference numeral 710 represents the handle and reference numeral 700 represents an interlocking container including the handle 710 according to another embodiment.

[0035] The spirit of the present invention has been just exemplified. It will be appreciated by those skilled in the art that various modifications, changes, and substitutions can be made without departing from the essential characteristics of the present invention. Accordingly, the embodiments disclosed in the present invention and the accompanying drawings are used not to limit but to describe the spirit of the present invention. The scope of the present invention is not limited only to the embodiments and the accompanying drawings. The protection scope of the present invention must be analyzed by the appended claims and it should be analyzed that all spirits within a scope equivalent thereto are included in the appended claims of the present invention.

[0036] The interlocking container can store various and many contents rather than a general container. Accordingly, it is expected that the interlocking container will be spread more widely than the general container hereinafter. Therefore, the interlocking container according to the present invention has high industrial availability.

Claims

1. An interlocking container, comprising:

a container body that includes a projecting portion bent downward, which is provided at the circumference of an exterior wall, a first groove grooved at an upper end of the projecting portion in a predetermined depth, and a hill portion that is provided at an entrance of the first groove and projects from an upper end of the projecting portion;

a wing that includes a pair of hinges projecting at one side of the exterior wall, a support body hinge-coupled with the hinge, and a fixation projecting piece projecting on one end of the support body to form a predetermined angle to the support body, which fits in the first groove through the fixation projecting piece; and

a cover that includes the projecting portion provided at the circumference of the exterior wall and the hill portion provided on the top surface of the projecting portion, which covers the upper part of the container body.

2. The interlocking container according to claim 1, wherein the container body includes a second groove formed by the exterior wall and the projecting portion and a packing made of a flexible material, which is provided in the second groove.

3. The interlocking container according to claim 1, wherein the wing further includes a handle provided in the support body.

4. The interlocking container according to claim 1, wherein the container body further includes a joining fixation portion that connects the hinge formed on one surface of the container body with the hinge formed on the other surface of the container body in order to fix the container body.

5. The interlocking container according to claim 1, wherein the interlocking container is molded by a plastic material and is transparent.

6. The interlocking container according to claim 1, wherein the cover includes a grippable handle mounted on the top surface thereof.

FIG. 1

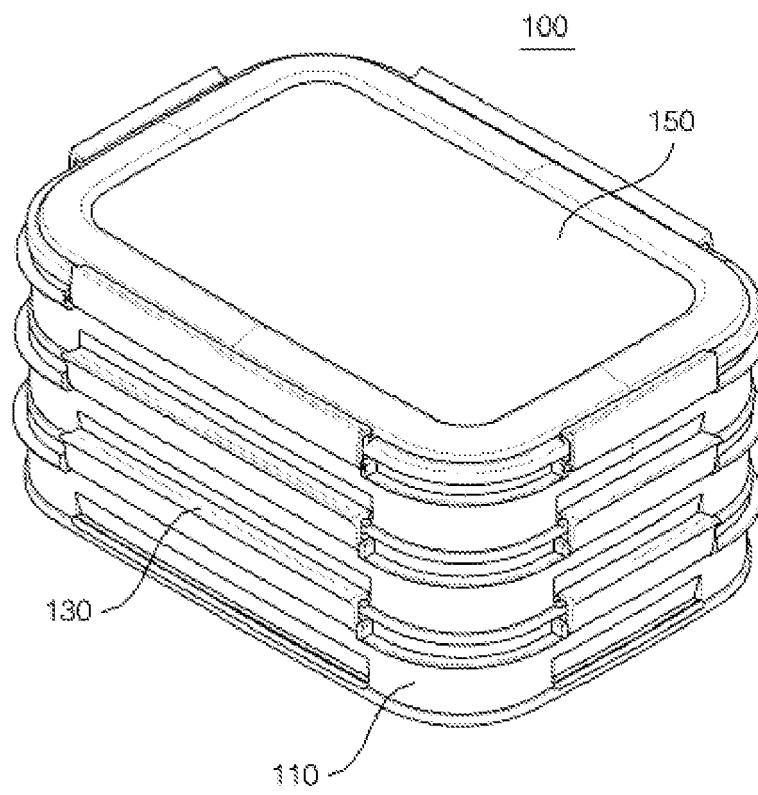

[FIG. 2]

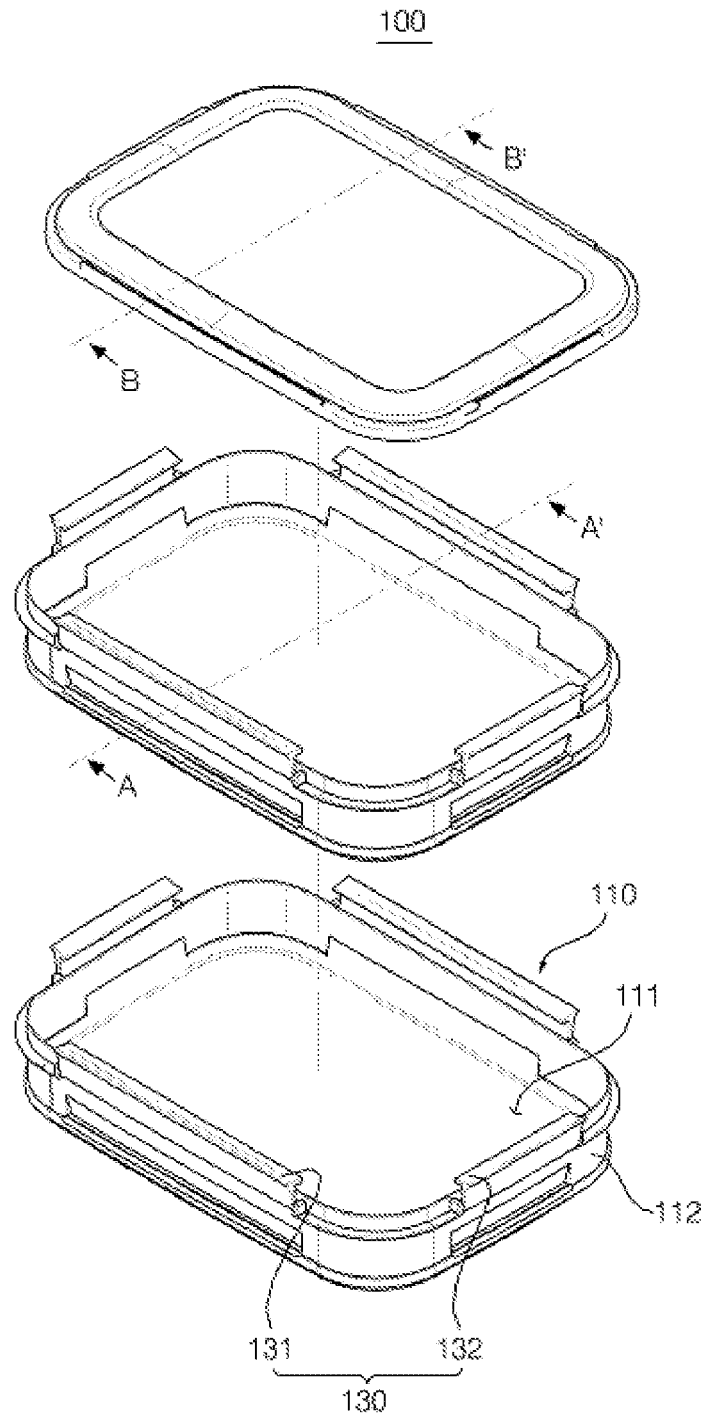

[FIG. 3]

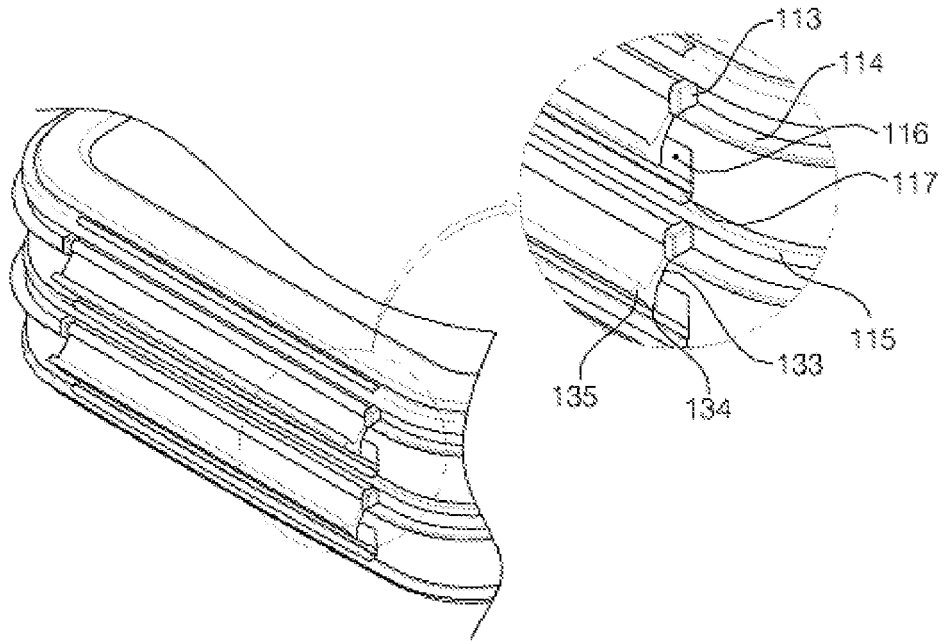

[FIG. 4]

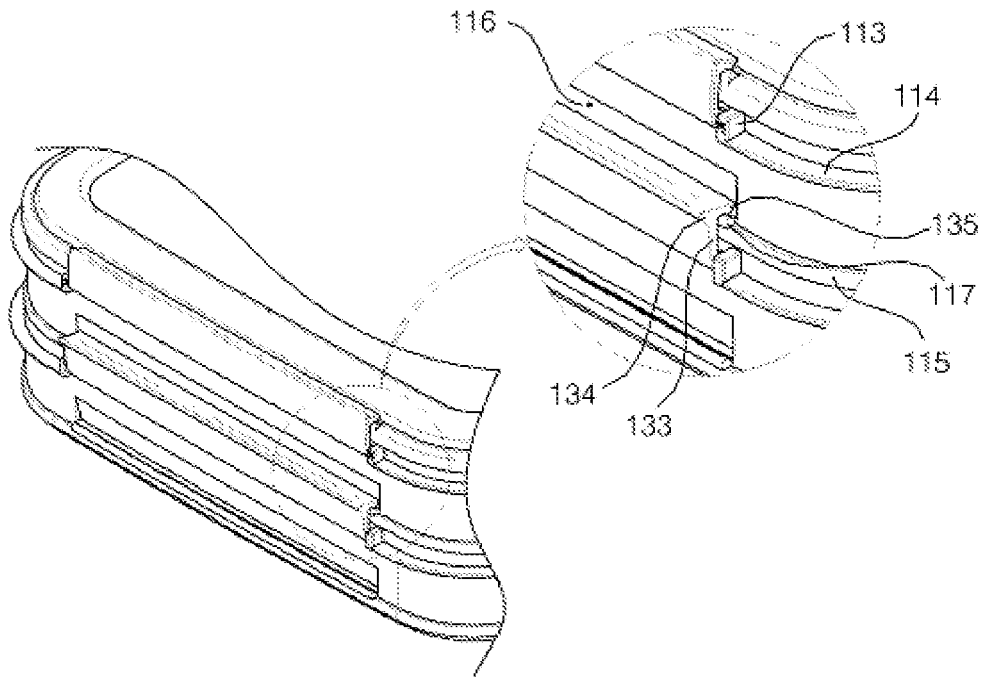

[FIG. 5]

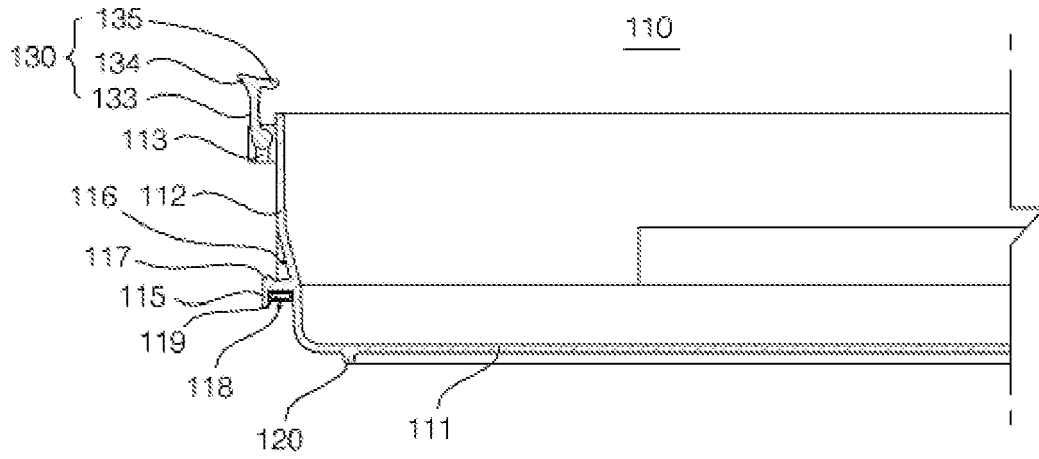

[FIG. 6]

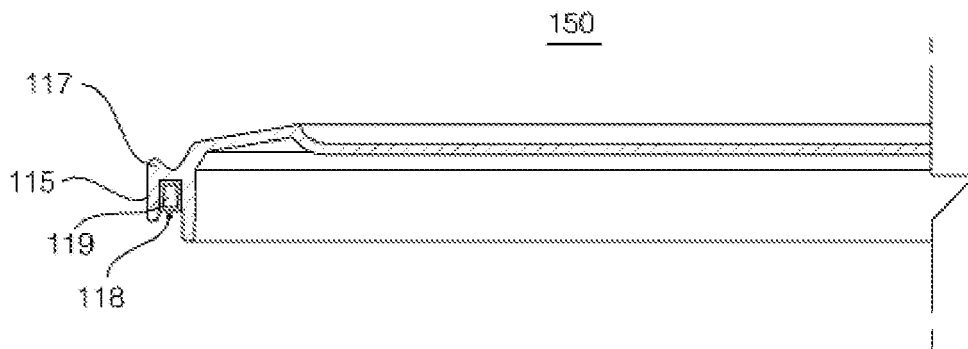

[FIG. 7]

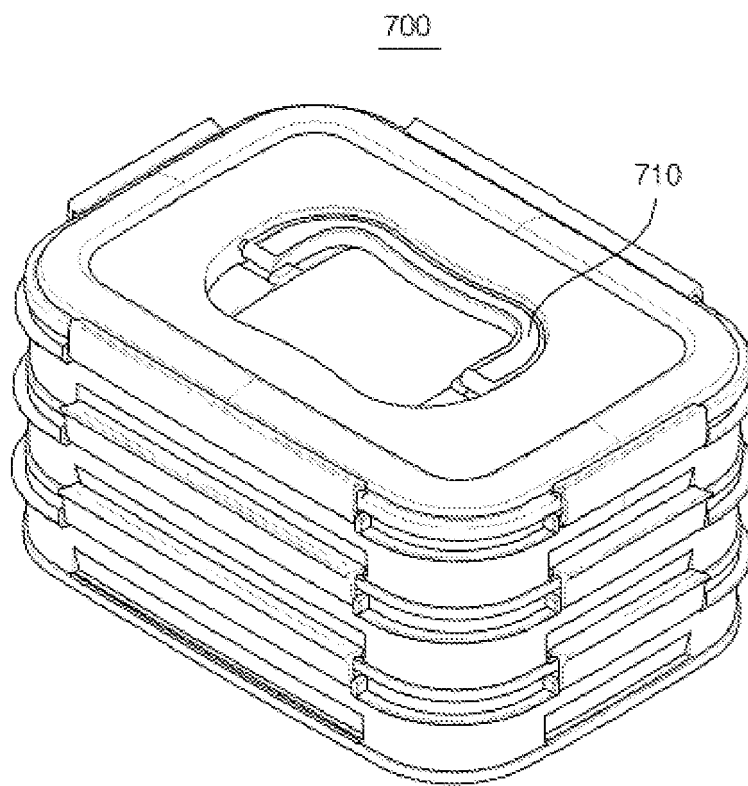



EUROPEAN SEARCH REPORT

Application Number
EP 09 15 2678

DOCUMENTS CONSIDERED TO BE RELEVANT			
Category	Citation of document with indication, where appropriate, of relevant passages	Relevant to claim	CLASSIFICATION OF THE APPLICATION (IPC)
X	US 6 321 925 B1 (CROUSE DOUGLAS N [US] ET AL) 27 November 2001 (2001-11-27) * the whole document *	1,3-5	INV. B65D21/02 B65D45/22
Y	-----	2,6	
Y	DE 72 44 356 U (AESULAP WERKE AG) 16 May 1974 (1974-05-16) * page 5, last paragraph; figure 4 *	2	
A	-----	1,4	
Y	DE 20 2006 008894 U1 (JELENIA PLAST SP Z O 0 [PL]) 3 August 2006 (2006-08-03) * paragraph [0021]; figures *	6	
A	GB 2 136 398 A (FARNELL JAMES WILLIAM) 19 September 1984 (1984-09-19) * page 1, line 121 - line 127; figure 2 *	2	
A	AU 645 008 B2 (KADER PLASTICS PTY LTD) 6 January 1994 (1994-01-06) * page 7, line 5 - page 8, line 2; figures *	1,3	
A	----- US 6 273 258 B1 (PIACENZA GIUSEPPE [IT]) 14 August 2001 (2001-08-14) * abstract; figures *	1	TECHNICAL FIELDS SEARCHED (IPC) B65D
The present search report has been drawn up for all claims			
Place of search The Hague		Date of completion of the search 23 April 2009	Examiner Gino, Christophe
CATEGORY OF CITED DOCUMENTS X : particularly relevant if taken alone Y : particularly relevant if combined with another document of the same category A : technological background O : non-written disclosure P : intermediate document		T : theory or principle underlying the invention E : earlier patent document, but published on, or after the filing date D : document cited in the application L : document cited for other reasons ----- & : member of the same patent family, corresponding document	

1
EPO FORM 1503 03.82 (F04C01)

**ANNEX TO THE EUROPEAN SEARCH REPORT
ON EUROPEAN PATENT APPLICATION NO.**

EP 09 15 2678

This annex lists the patent family members relating to the patent documents cited in the above-mentioned European search report. The members are as contained in the European Patent Office EDP file on
The European Patent Office is in no way liable for these particulars which are merely given for the purpose of information.

23-04-2009

Patent document cited in search report	Publication date	Patent family member(s)	Publication date
US 6321925	B1	27-11-2001	NONE
DE 7244356	U		NONE
DE 202006008894	U1	03-08-2006	NONE
GB 2136398	A	19-09-1984	NONE
AU 645008	B2	06-01-1994	AU 5292390 A 04-10-1990
US 6273258	B1	14-08-2001	NONE

EPO FORM P0459

For more details about this annex : see Official Journal of the European Patent Office, No. 12/82