



US00D890060S

(12) **United States Design Patent**
Buttigieg

(10) **Patent No.:** **US D890,060 S**

(45) **Date of Patent:** **** Jul. 14, 2020**

(54) **WHEEL**

(71) Applicant: **Jaguar Land Rover Limited**, Whitley,
Coventry (GB)

(72) Inventor: **Tom Buttigieg**, Coventry (GB)

(73) Assignee: **Jaguar Land Rover Limited**, Whitley,
Coventry (GB)

(**) Term: **15 Years**

(21) Appl. No.: **29/642,060**

(22) Filed: **Mar. 27, 2018**

(30) **Foreign Application Priority Data**

Oct. 3, 2017 (EM) 004383248

(51) **LOC (12) Cl.** **12-16**

(52) **U.S. Cl.**
USPC **D12/209**

(58) **Field of Classification Search**

USPC D12/204–213; D21/563
CPC B60B 7/00; B60B 7/02; B60B 7/04; B60B
7/01; B60B 7/06; B60B 3/02; B60B 3/04;
B60B 3/06; B60B 3/10; B60B 1/00;
B60B 1/08; B60B 1/10; B60B 1/12

See application file for complete search history.

(56) **References Cited**

U.S. PATENT DOCUMENTS

D460,037 S * 7/2002 Takechi D12/211
D469,048 S * 1/2003 van Hooydonk D12/209
(Continued)

Primary Examiner — Stacia A Cadmus

(74) *Attorney, Agent, or Firm* — Wood Herron & Evans
LLP

(57) **CLAIM**

The ornamental design for a wheel, as shown and described.

DESCRIPTION

FIG. 1 is a front left perspective view of a wheel for a vehicle according to the present invention;

FIG. 2 is a front view of the wheel shown in FIG. 1;

FIG. 3 is a left side view thereof, the right side being a mirror image thereof;

FIG. 4 is a front left perspective view of a wheel according to a second embodiment.

FIG. 5 is a front view of FIG. 4;

FIG. 6 is a left side view of FIG. 4.

FIG. 7 is a left side view thereof, the right side view being a mirror image thereof.

FIG. 8 is a rear view thereof.

FIG. 9 is a rear right perspective view thereof.

FIG. 10 is a rear left perspective view thereof.

FIG. 11 is a front left perspective view of a wheel for a vehicle according to another alternative embodiment of the present invention.

FIG. 12 is a front view of the wheel shown in FIG. 1.

FIG. 13 is a left side view thereof, the right side view being a mirror image thereof.

FIG. 14 is a front left perspective view of a wheel for a vehicle according to still another alternative embodiment of the present invention.

FIG. 15 is a front right perspective view of the wheel shown in FIG. 14.

FIG. 16 is a front view thereof.

FIG. 17 is a left side view thereof, the right side view being a mirror image thereof.

FIG. 18 is a rear view thereof.

FIG. 19 is a rear right perspective view thereof; and,

FIG. 20 is a rear left perspective view thereof.

The broken lines show environmental structure and form no part of the claimed invention.

In FIGS. 1-3 and 11-13, the broken line showing of the rear of the rim, the bolt holes, and the center hole in the central hub area is included for the purpose of illustrating environment and forms no part of the claimed design.

1 Claim, 14 Drawing Sheets

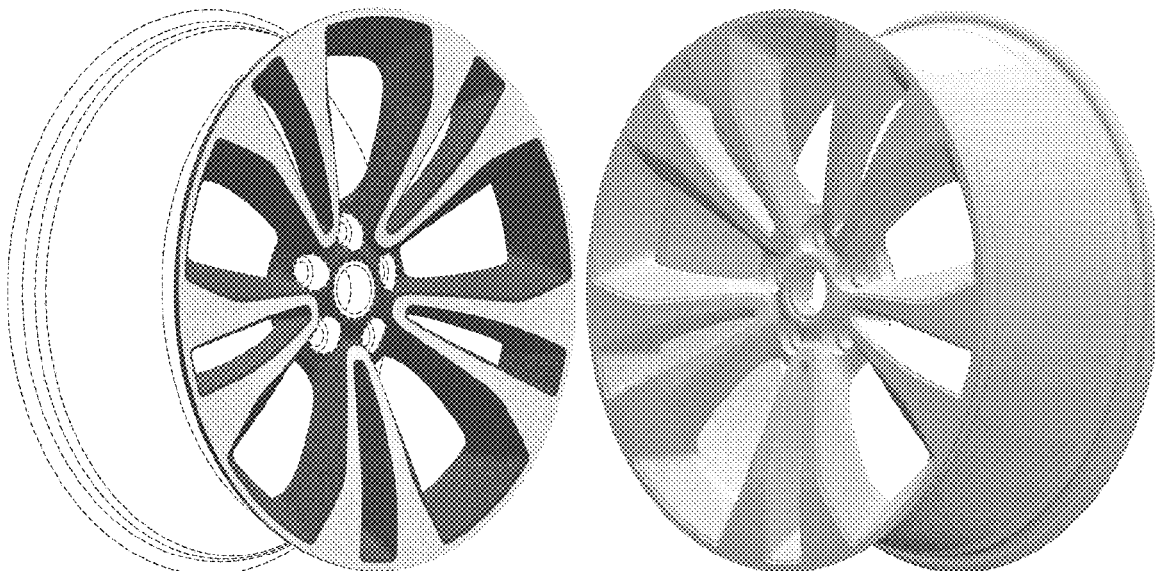

(56)

References Cited

U.S. PATENT DOCUMENTS

D477,262	S	*	7/2003	Koch	D12/209
D540,240	S	*	4/2007	Kountouras	D12/211
D594,396	S	*	6/2009	Juergens	D12/209
D594,802	S	*	6/2009	Gustafsson	D12/211
D639,716	S	*	6/2011	Juergens	D12/211
D641,679	S	*	7/2011	Vardis	D12/211
D650,315	S	*	12/2011	Juergens	D12/211
D713,317	S	*	9/2014	Akojima	D12/211
D723,987	S	*	3/2015	Kito	D12/209
D723,988	S	*	3/2015	Kito	D12/209
D729,720	S	*	5/2015	Chen	D12/211
D741,237	S	*	10/2015	Furst	D12/209
D746,752	S	*	1/2016	Beaven	D12/209
D751,020	S	*	3/2016	Mahoney	D12/211
D753,044	S	*	4/2016	Mielke	D12/209
D760,139	S	*	6/2016	Dionisopoulos	D12/209
D767,464	S	*	9/2016	Juergens	D12/209
D787,409	S	*	5/2017	Smith	D12/211
D795,148	S	*	8/2017	Ariga	D12/209
D811,979	S	*	3/2018	Svensson	D12/211
D834,488	S	*	11/2018	Smith	D12/209
D840,897	S	*	2/2019	Aiba	D12/209
D858,402	S	*	9/2019	Betancourt	D12/209
D864,074	S	*	10/2019	Badstuebner	D12/209

* cited by examiner

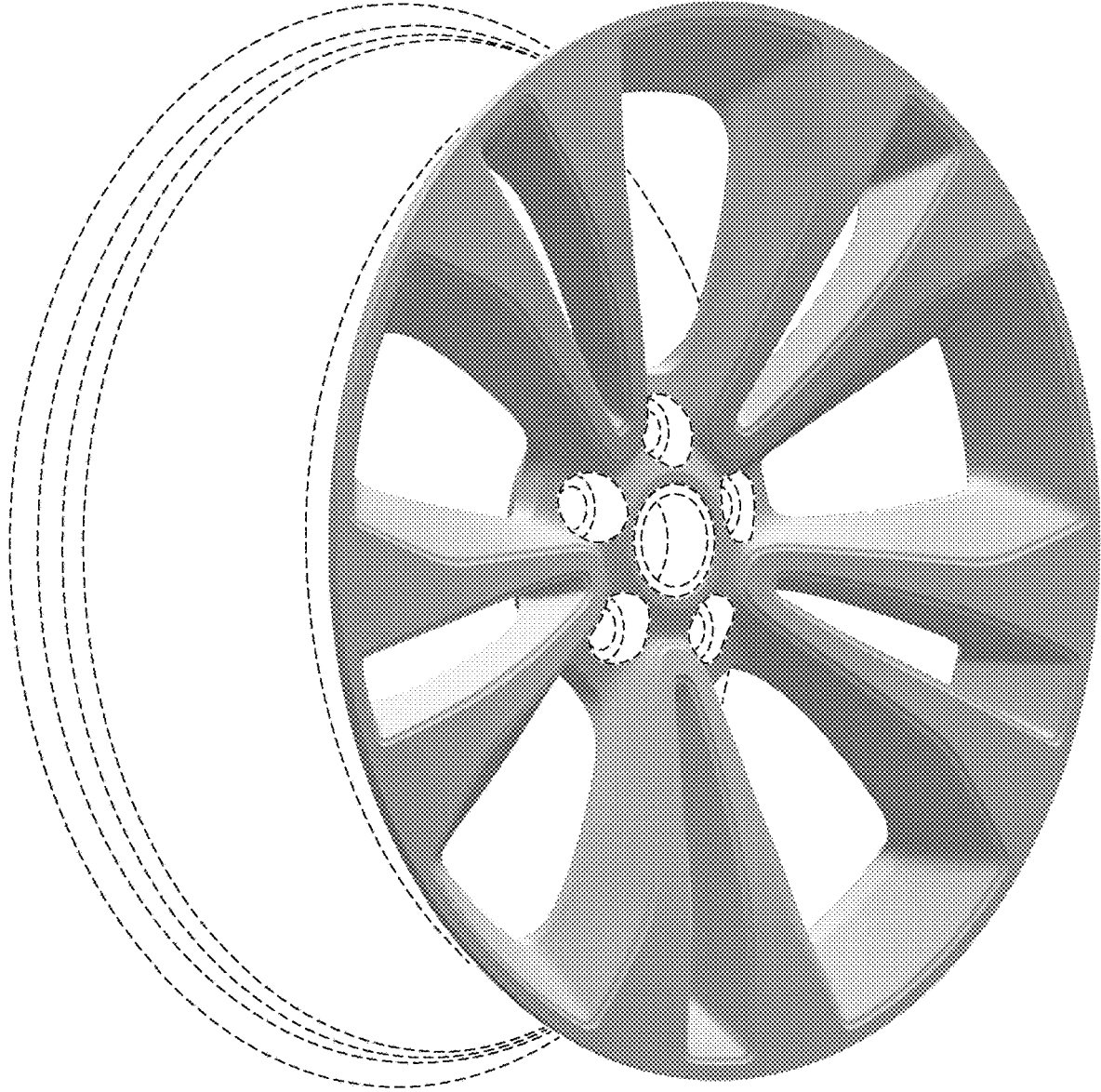

FIG. 1

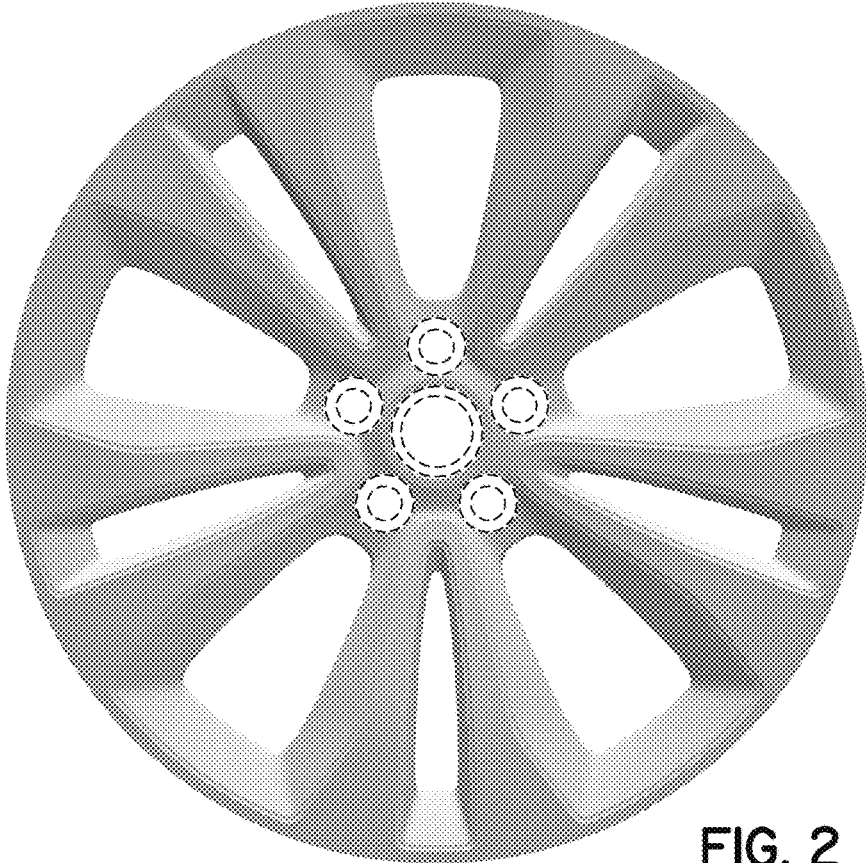

FIG. 2

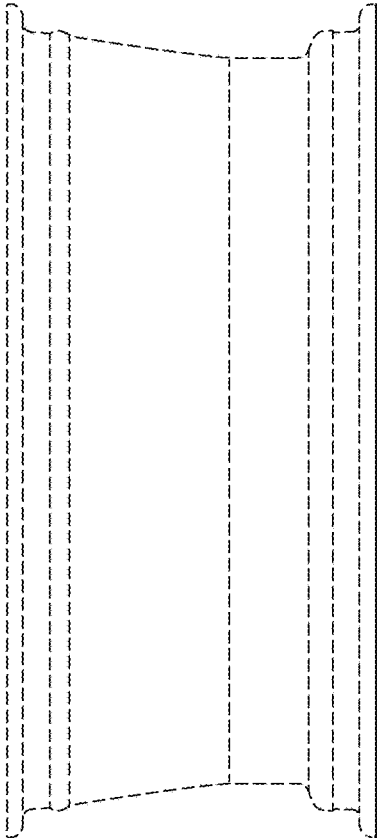

FIG. 3

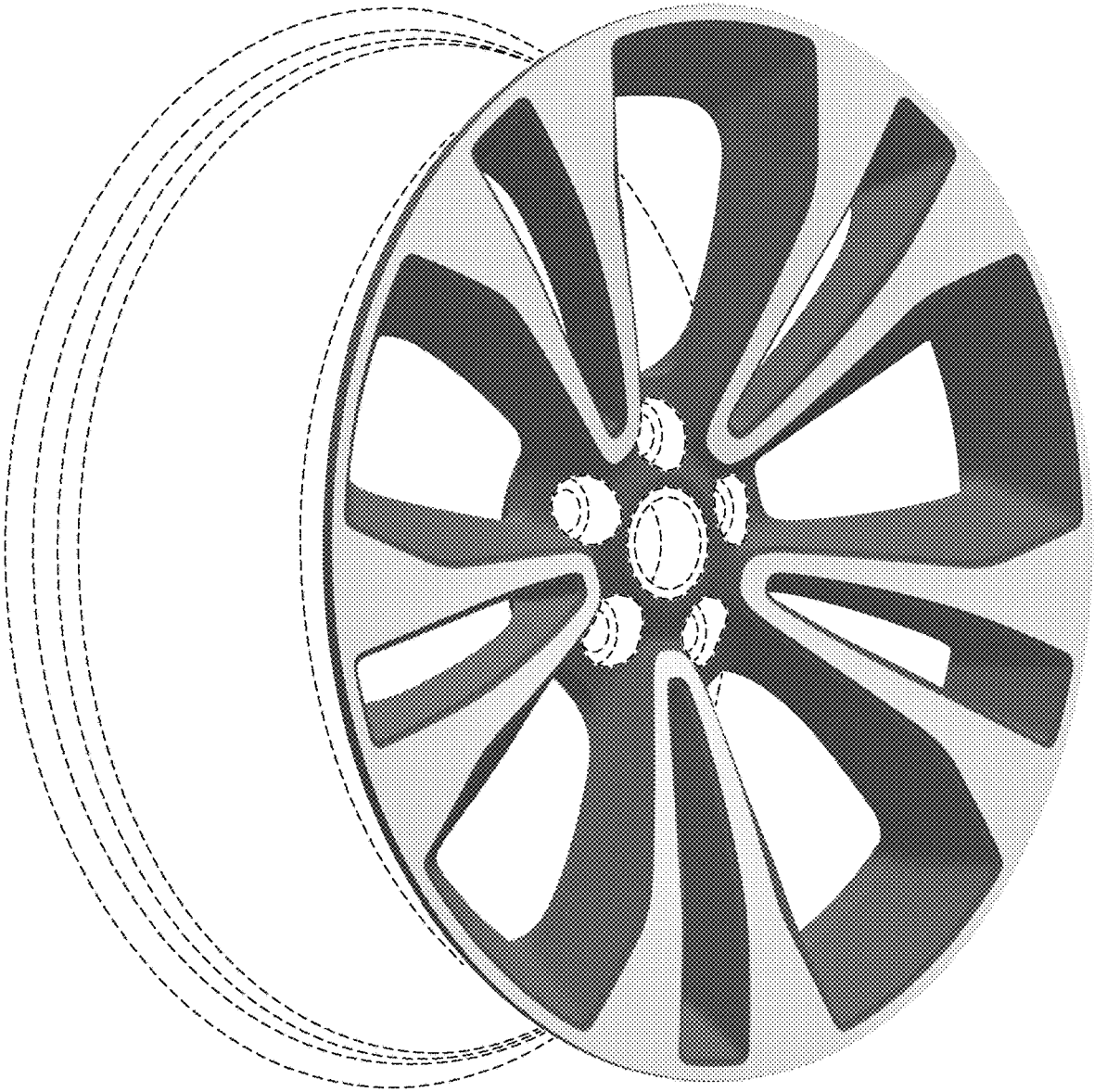

FIG. 4



FIG. 5

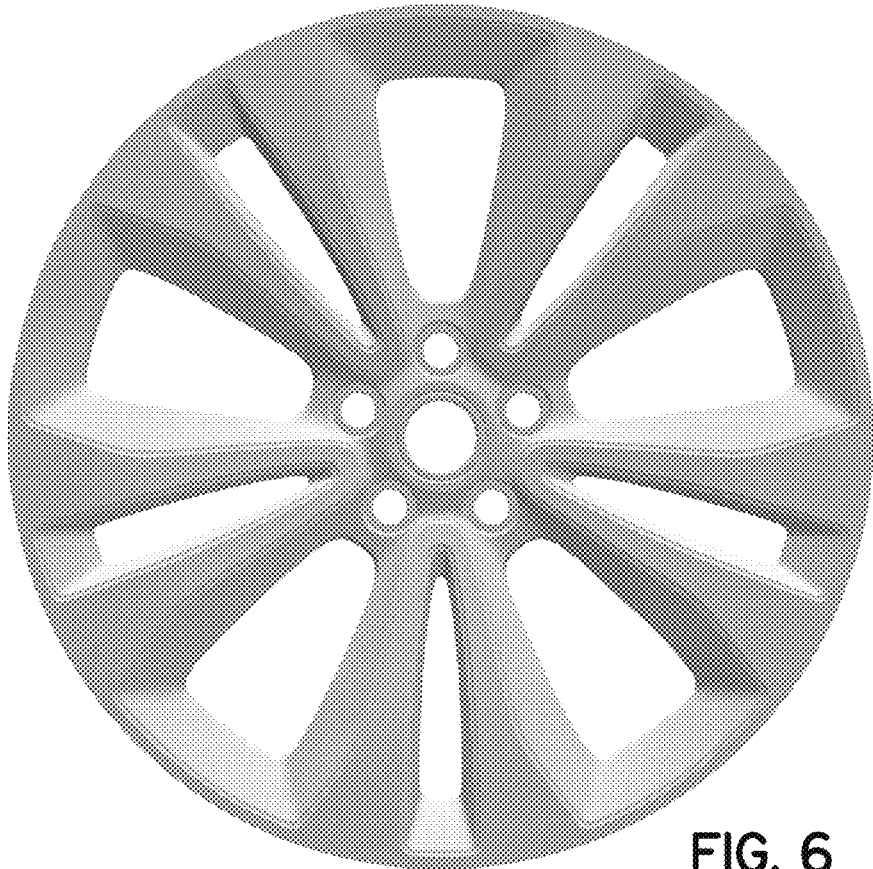

FIG. 6

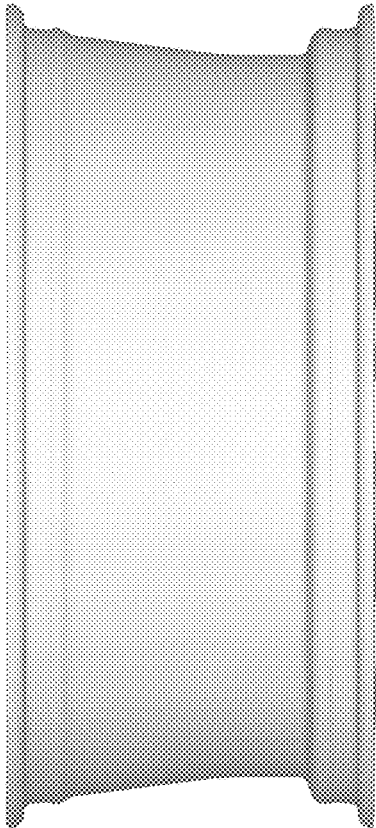

FIG. 7

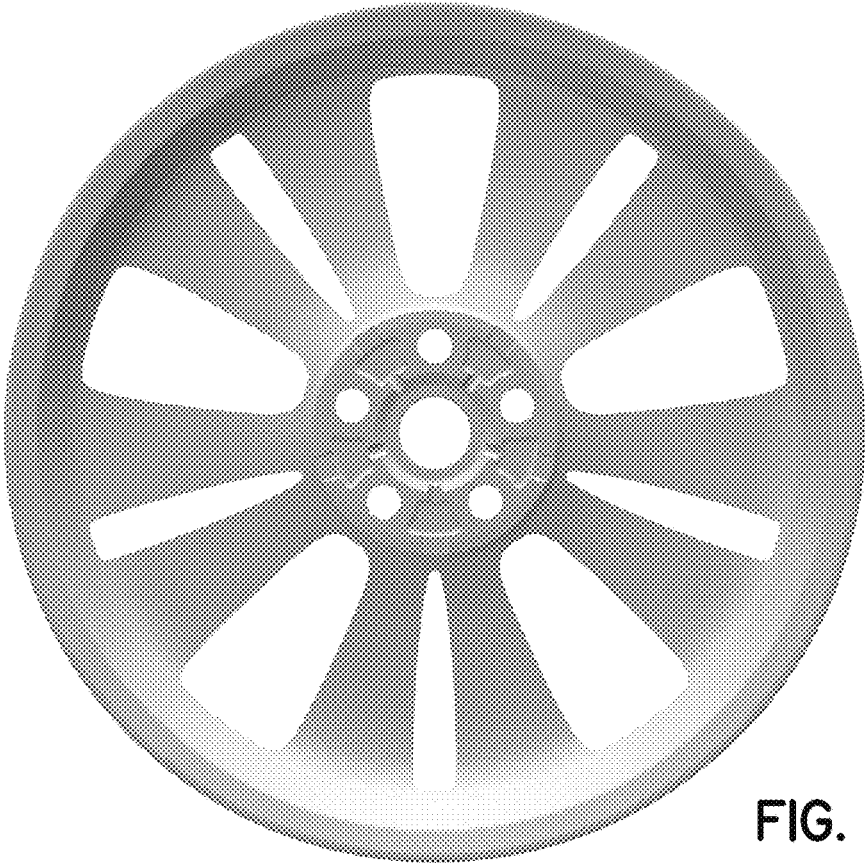

FIG. 8

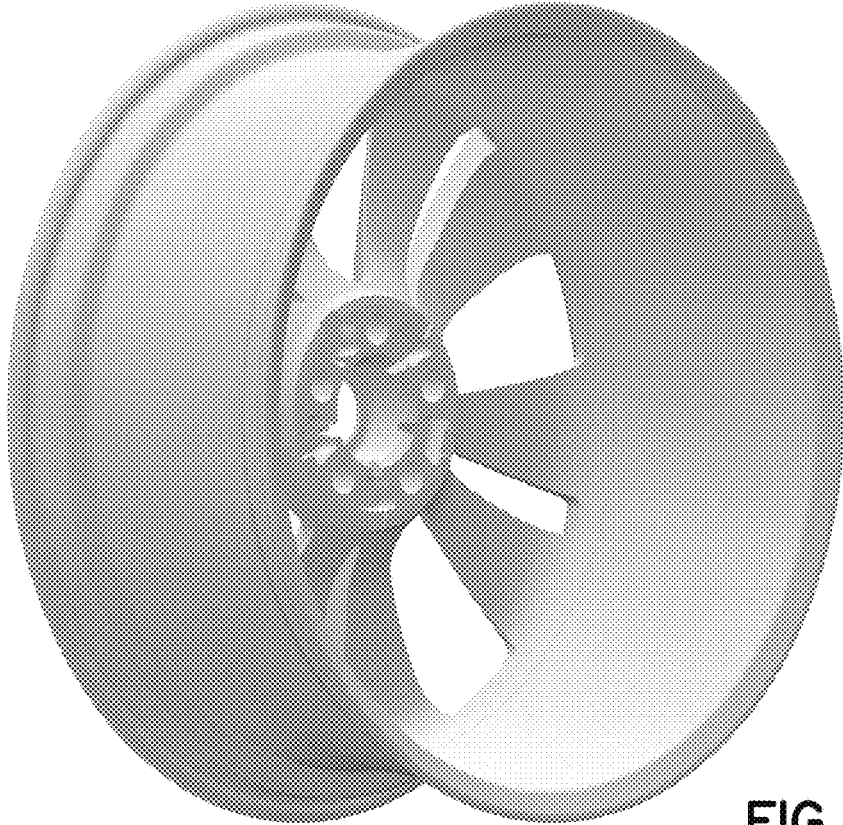

FIG. 9

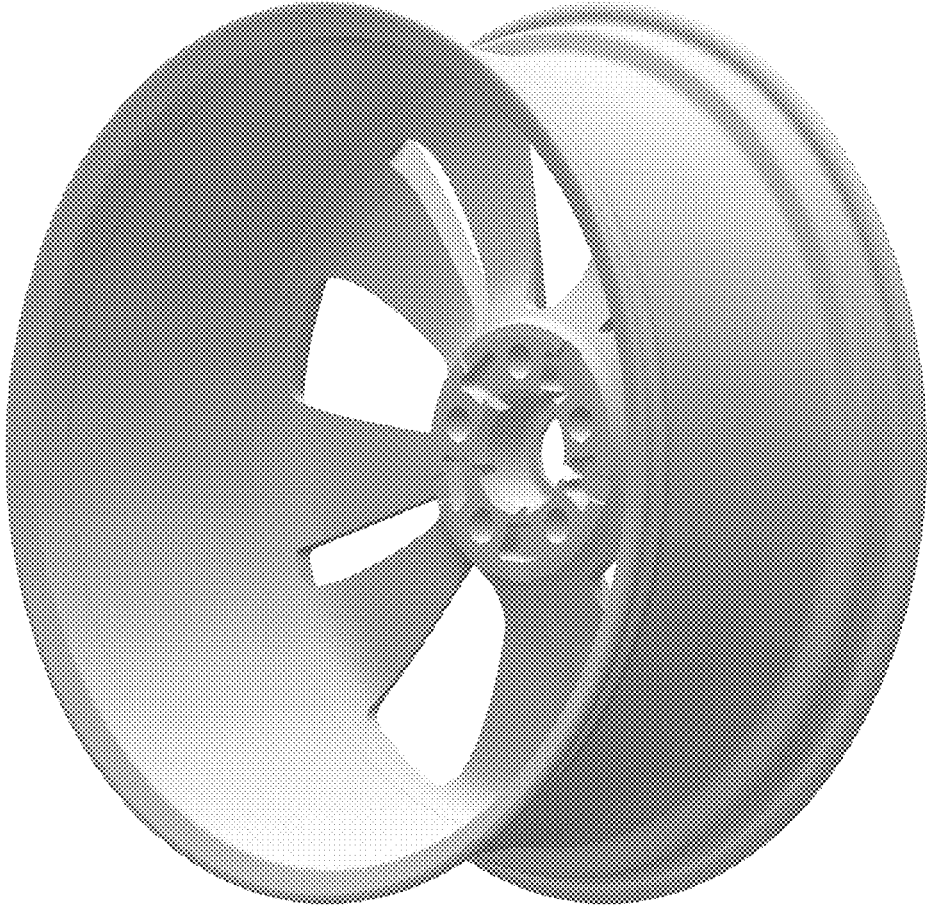

FIG. 10

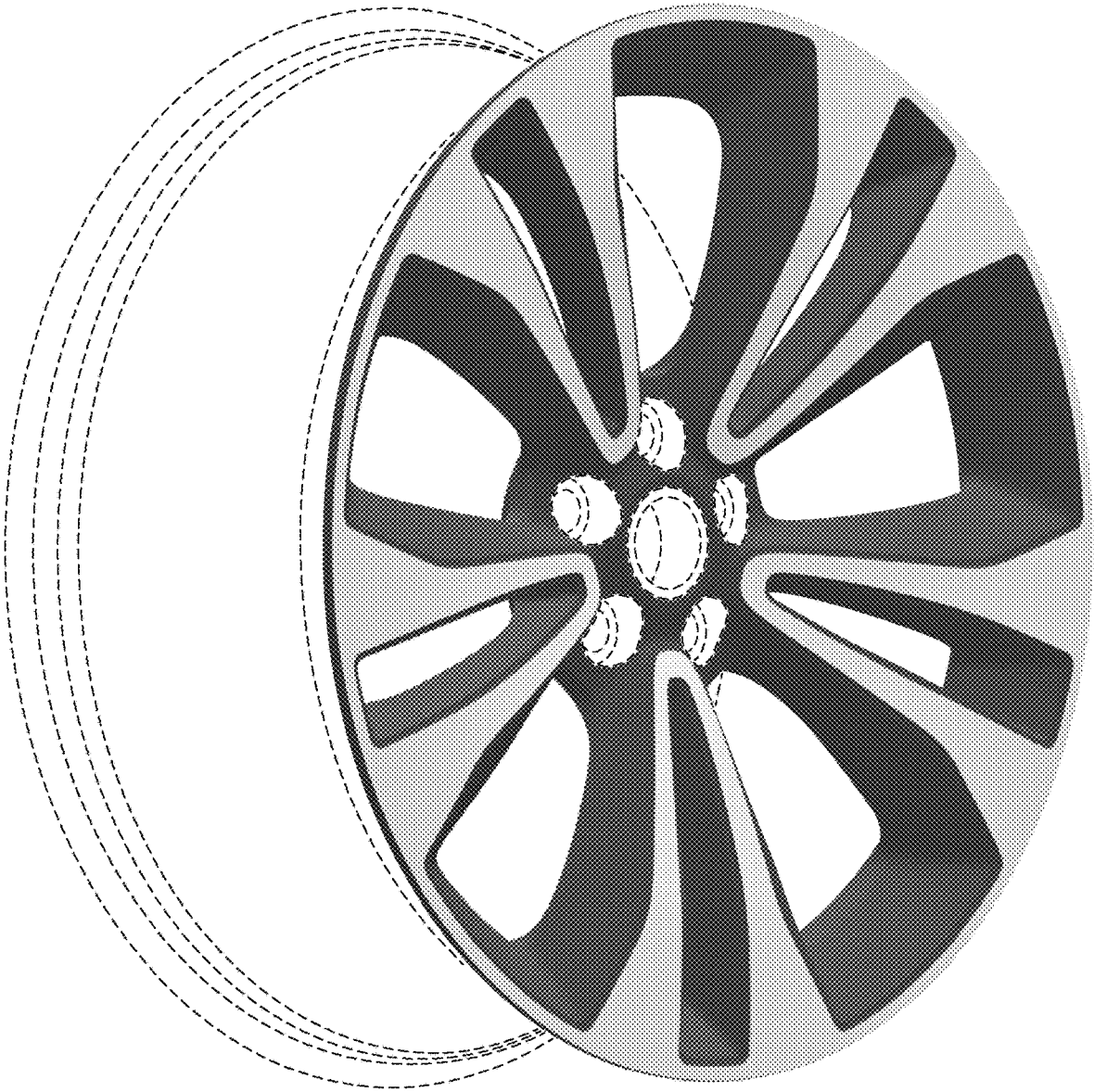

FIG. 11

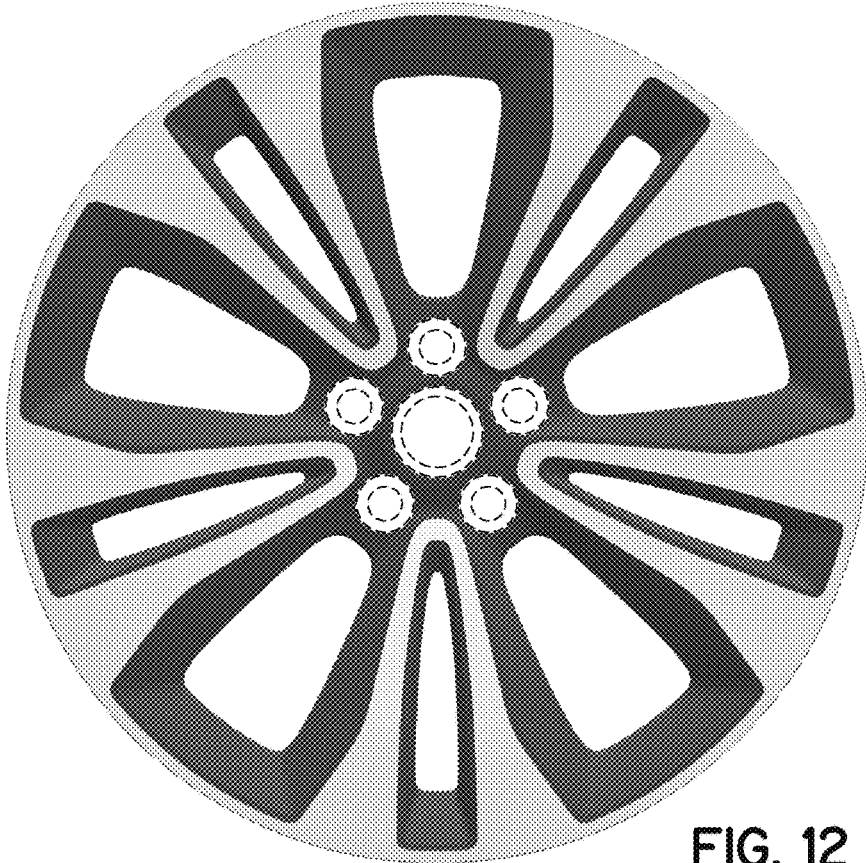

FIG. 12

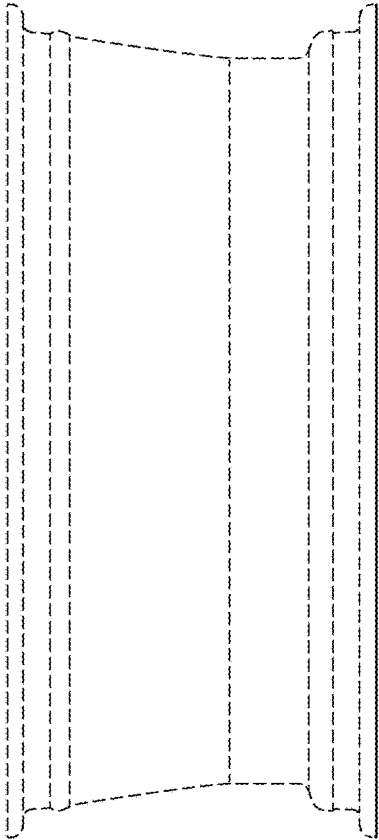

FIG. 13



FIG. 14



FIG. 15

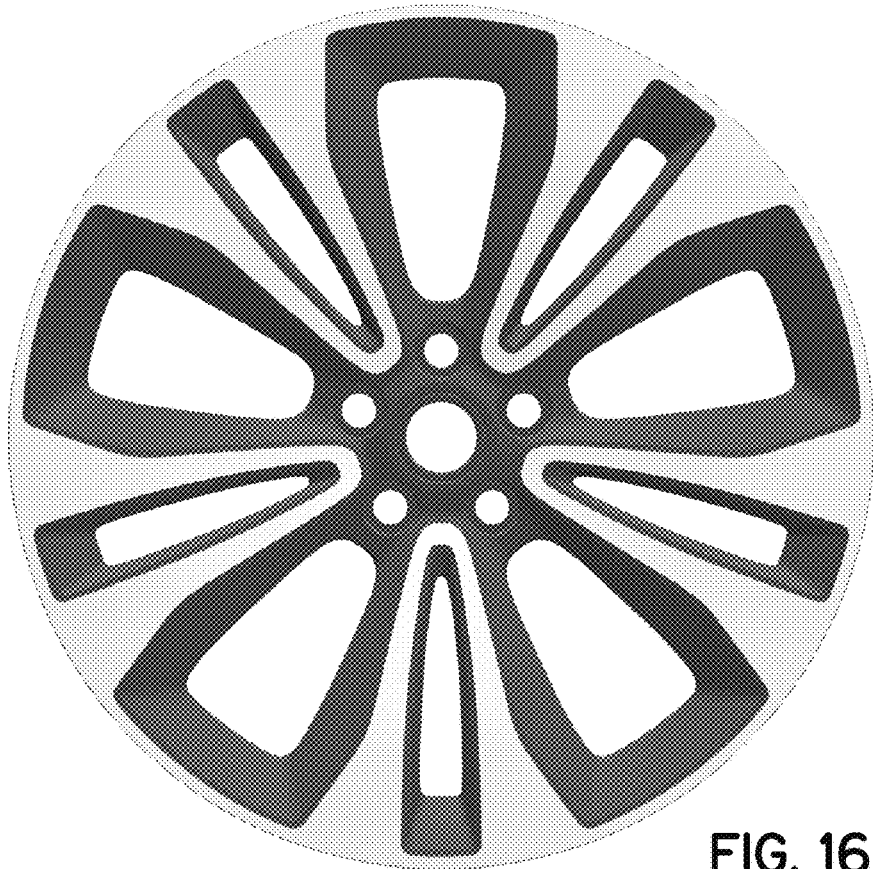

FIG. 16

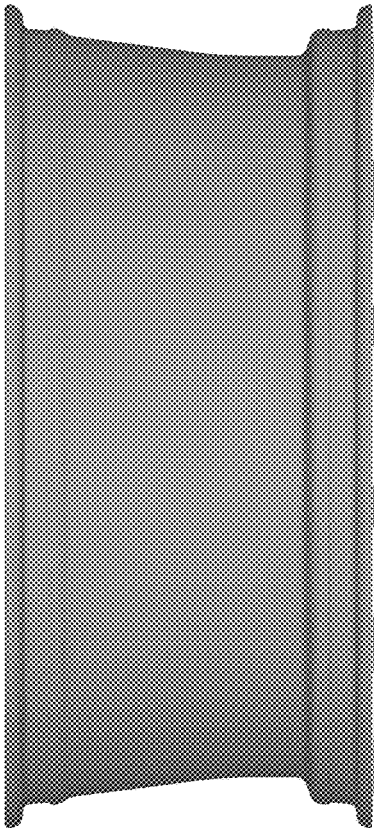

FIG. 17

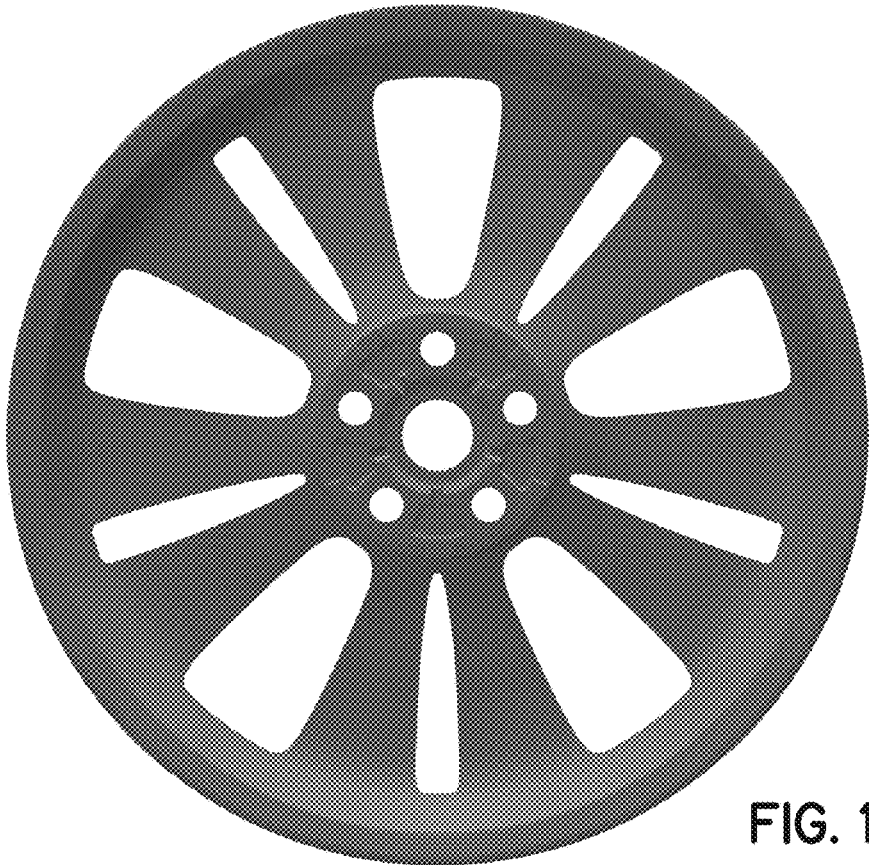

FIG. 18

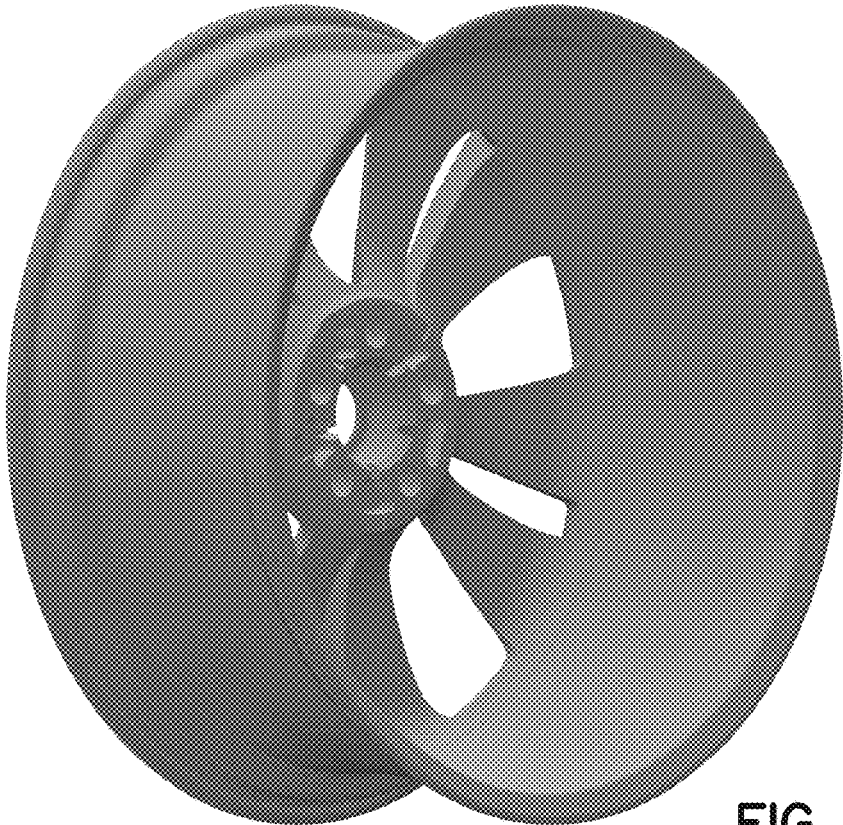

FIG. 19



FIG. 20

UNITED STATES PATENT AND TRADEMARK OFFICE
CERTIFICATE OF CORRECTION

PATENT NO. : D890,060 S
APPLICATION NO. : 29/642060
DATED : July 14, 2020
INVENTOR(S) : Tom Buttigieg

Page 1 of 1

It is certified that error appears in the above-identified patent and that said Letters Patent is hereby corrected as shown below:

On the Title Page

Column 2, under "Description," Line 10, reads "FIG. 6 is a left side view of Fig. 4," and should read
--FIG. 6 is a left side view of FIG. 4, the right side view being a mirror image thereof--.

Signed and Sealed this
Sixth Day of September, 2022

Katherine Kelly Vidal
Director of the United States Patent and Trademark Office