



(11) **EP 3 553 271 A1**

(12) **EUROPEAN PATENT APPLICATION**

(43) Date of publication:
16.10.2019 Bulletin 2019/42

(51) Int Cl.:
E21B 10/573^(2006.01) E21C 35/183^(2006.01)

(21) Application number: **19163685.1**

(22) Date of filing: **19.03.2019**

(84) Designated Contracting States:
AL AT BE BG CH CY CZ DE DK EE ES FI FR GB GR HR HU IE IS IT LI LT LU LV MC MK MT NL NO PL PT RO RS SE SI SK SM TR
 Designated Extension States:
BA ME
 Designated Validation States:
KH MA MD TN

(71) Applicant: **The Sollami Company**
Herrin, IL 62948 (US)

(72) Inventor: **Sollami, Phillip**
Herrin, IL 62948 (US)

(74) Representative: **Haseltine Lake Kempner LLP**
Redcliff Quay
120 Redcliff Street
Bristol BS1 6HU (GB)

(30) Priority: **11.04.2018 US 201815950676**

(54) **DIAMOND INSERT WITH HEAT TRANSFER BORE**

(57) An improved diamond coated bit tip insert (316) on a bit/holder, tool, and/or pick for road milling operations that includes a body including a tip and a base adjacent the tip, the tip including an overlay (318) on an outer surface of the tip. The bit tip insert also includes at least one heat transfer bore (328) extending from a distal end and/or bottom of the body to a bore termination adjacent the tip. The at least one bore of the bit tip insert is adapted to allow inward contraction when the overlay transfers heat into the base during operation.

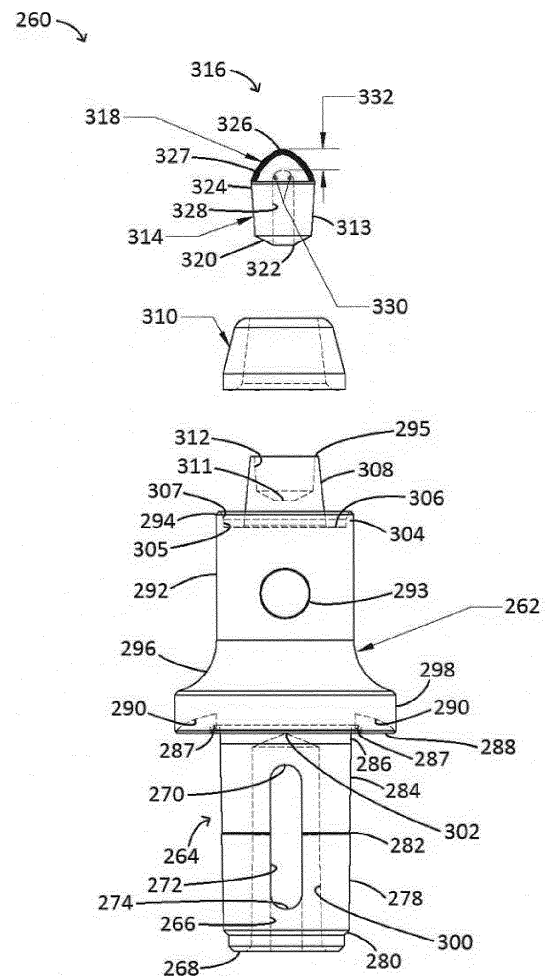

FIG. 13

EP 3 553 271 A1

Description

TECHNICAL FIELD

[0001] This disclosure relates to bit/bit holder combinations and, more particularly, to such a combination utilizing a larger PCD diamond layered ballistic tip insert with at least one heat transfer bore.

BACKGROUND

[0002] As basic infrastructure created in the 20th Century ages and wears, machinery for rejuvenating or replacing that infrastructure has become more important. While mining and trenching operation machinery may be included in this technology, road milling machinery, down hole tools in the oil well industry, and other similar industries area, thus far, the most prolific use of the instant machinery.

[0003] Road milling equipment utilizes a rotating drum having a plurality of bit assemblies removably mounted on the outside of the drum in spiral or chevron orientation. A typical rotating drum has a bit tip to bit tip diameter of between 42 and 54 inches and includes a plurality of mounting blocks generally secured thereto by welding in spiral or chevron patterns. The patterns noted provide for the bit blocks to be mounted behind and slightly axially to the side of one another such that the bits or combination bit/holders mounted in each bit block may have the tips of the bits positioned in close proximate relation along the axial length of the drum. As such, adjacent bit tips may be positioned anywhere from about .200 inch to about 5/8 inch axially apart for either removing concrete, asphalt, or the like, when replacing one or both of the pavement and underlayment for roadways, or may be positioned axially closer together, about .200 inch, for micro milling the surface of pavement to remove buckles, create grooves on curved surfaces such as cloverleaves, or the like.

[0004] Improvements in the bits and bit/holders that are removably mounted on the bit blocks have increased the useful in-service life of those removable parts. While such bit and bit/holders have been made of steel and hardened materials such as tungsten carbide, the use of diamond coated tips and man-made PCD (polycrystalline diamond) tips, has been shown to increase the in-service life of those bits and bit/holders.

[0005] Another improvement in bit/holders has been the invention of quick change holders that have eliminated the necessity of securing such holders with threaded nuts or retaining clips and have utilized the compressive elastic ductility of hardened steel to provide sufficient radial force between the holders and the bit block bores to retain holders mounted in their respective bit block bores during operation. While such bit assemblies have included rotatable and removable bits mounted in bit holders which, in turn, were mounted in bit blocks as noted above, the introduction of diamond materials on bit tips has in-

creased their in-service life 40 to 80 times and has, in some cases, allowed for the combining of bits and bit holders into a unitary construction with the tips no longer being rotatable on the holders.

5 **[0006]** A need has developed for improved structure at the front leading end or tip end of bit/holders that provide for improved wear characteristics, in-service life and finer milled road surfaces at reduced total cost.

10 SUMMARY

[0007] This disclosure relates generally to bit and/or pick assemblies for road milling, mining, and trenching equipment. One implementation of the teachings herein is a bit tip insert that includes a body comprising a tip and a base subjacent the tip, the tip including an overlay on an outer surface of the tip; and a first bore axially extending from a distal end of the body to a first bore termination adjacent the tip, the first bore adapted to allow inward contraction when the overlay transfers heat into the base during operation.

15 **[0008]** These and other aspects of the present disclosure are disclosed in the following detailed description of the embodiments, the appended claims and the accompanying figures.

BRIEF DESCRIPTION OF THE DRAWINGS

20 **[0009]** The features of the present disclosure which are believed to be novel are set forth with particularity in the appended claims. The disclosure may best be understood from the following detailed description of currently illustrated embodiments thereof taken in conjunction with the accompanying drawings wherein like numerals refer to like parts, and in which:

Fig. 1 is a front elevational view of a first embodiment of a bit/holder constructed in accordance with the present disclosure including a first embodiment of an improved and enlarged leading tip section;

Fig. 2a is a cross section view of a prior art 0.565 inch PCD tip insert mounted on a recess in a pick bolster;

Fig. 2b is a fragmentary cross section view of the 0.75 inch diameter PCD layered tip insert as in Fig. 1 shown for comparison purposes with the prior art disclosed on the other Fig. 2 drawings;

Fig. 2c is a diagram view showing the prior art tip of Fig. 2a superimposed on the front portion of the enlarged tip of Fig. 2b;

Fig. 2d is a fragmentary photograph of another prior art tip having a 0.565 inch diameter conical distal end;

Fig. 3 is a front elevational view of a second embodiment of a bit/holder constructed in accordance with the disclosure showing a second embodiment of a tip having a slight reverse taper in the aft or body portion thereof which is mounted on the front of the

holder portion thereof;

Fig. 4 is a photograph showing a front elevational view of a prior art bit/holder after substantial in-service use showing the wear characteristics on it after substantial use;

Fig. 5 is a photograph showing a side elevational view of the prior art bit/holder shown in Fig. 4 wherein separated material has flowed past the left side of the bit/holder in use;

Fig. 6 is an enlarged diagrammatic elevational detail view of a third embodiment of the enlarged tip insert;

Fig. 7 is a diagrammatic stop motion side view of the partial sweep of a bit assembly as it moves through its material separating operation;

Fig. 8 is a diagrammatic front view taken at 90 degrees to Fig. 7 showing the added side overlap of successive bit assemblies resulting in a finer finish cut using a drum with standard 0.625 inch center-to-center tip spacing;

Fig. 9 is a side elevation view of a third embodiment of a bit/holder and a fourth embodiment of a tip insert in accordance with implementation of this disclosure;

Fig. 10 is an exploded side elevation view of the third embodiment of the bit/holder and the fourth embodiment of the tip insert in accordance with implementations of this disclosure;

Fig. 11 is a cross-section view of a fourth embodiment of a bit/holder and a fifth embodiment of a tip insert in accordance with implementations of this disclosure;

Fig. 12 is an exploded side elevation view of the fourth embodiment of a bit/holder and the fifth embodiment of the tip insert in accordance with implementations of this disclosure;

Fig. 13 is an exploded side elevation view of a fifth embodiment of a bit/holder and a sixth embodiment of a tip insert in accordance with implementations of this disclosure;

Fig. 14 is side elevation view of a seventh embodiment of a tip insert in accordance with implementations of this disclosure;

Fig. 15 is a bottom elevation view of the seventh embodiment of the tip insert in accordance with implementations of this disclosure; and

Fig. 16 is an exploded side elevation view of the fifth embodiment of the bit/holder and the seventh embodiment of the tip insert in accordance with implementations of this disclosure.

DETAILED DESCRIPTION

[0010] The diameter of the base of the PCD ballistic insert is determined by the required geometric profile of the forward end of the point attack tool. As the machine or equipment size diminishes, so does the amount of horsepower of the engine or the machine needed to operate the machine.

[0011] The ballistic or parabolic style profile of the tip

of the PCD insert provides a longer conic tip than a standard straight line side profile of a frustoconical tip. The longer parabolic tip has a greater PCD coated length with more structural strength. The included angle of the tip varies axially. Sollami PCD tool is 180 degrees indexable to achieve extended life over prior art diamond coated tools, while maintaining nearly exactly the same cut surface profile.

[0012] Referring to Figs. 1 and 2, a first embodiment of a bit/holder 10, constructed in accordance with the present disclosure, includes features from this inventor's previous U.S. Patent Nos. 6371567, 6585326 and 6739327 which show both the shank 11 at the rear of the bit/holder and the forward end 12 of the bit/holder 10 having a diamond coated tungsten carbide tip insert 13 mounted in a generally cylindrical recess 14 at the center of an annular flange 15 extending axially outwardly from the steel body portion of the bit/holder. This steel annular flange 15 provides ductility and shock absorption characteristics to the generally ballistic shape tip 13 that is preferably made of tungsten carbide having either a single 13b or multiple layer (See Fig. 6) of industrial diamond or PCD superstructure over the forward conical portion of the tip. Additionally, an annular ring 16 of tungsten carbide is mounted over the steel annular flange 15 for added wear resistance to the aft portion of holder. The tungsten carbide annular ring 16 is preferably brazed in an annular groove 17 at the top of the body portion 18 of the holder 10.

[0013] In the illustrated embodiment of the bit/holder 10 when used for road milling purposes, the nominal outer diameter of the shank 11 is about 1.5 inches and the nominal outer diameter of the widest portion of the body 18 of the holder is about 2-5/8 inches at what is termed the "tire portion" 20 of the holder body 18. The diameter of the upper cylindrical portion 18a of the body 18 $[[a]]$ is about 1-3/4 inches and the axial length of the body from the rear annular flange 21 to the front of the cylindrical portion is about 3 inches. The length of the shank 11 in the embodiments shown approximates 2-1/2 inches. As taught in my U.S. Provisional Patent Application No. 61/944,676, filed February 26, 2014, now U.S. Non-provisional Patent Application No. 14/628,482, filed February 23, 2015, and now U.S. Patent Application Publication No. 2015/0240634, published August 27, 2015, the contents of which are incorporated by reference, bit holder shanks may be shorter, on the order of 1-1/2 inches.

[0014] With the forward cylindrical end of a bit holder body 18 having a diameter of about 1-3/4 inches, prior art bits or pick bolsters have been designed to have a conical surface aiding in diverting pavement material away from the forward tip portion of the bit/holder or bit.

[0015] In designing these structures, tip inserts having a front conical tip of PCD or diamond layered material 13b, as shown in Fig. 1, have been selected to provide best results. The diameter of the tip insert at its widest point for holders sized as above has thus far been a tip insert made to a base diameter of about 0.565 inch. In

experimenting with such diamond covered tip insert structures, applicant has discovered that using such a tip having a nominal diameter of 0.625, 0.75, 0.875 inch or larger ballistic tip insert may still be inserted in a modified structure substantially similar to that previously shown in U.S. Patent No. 6,739,327. Thus, the improvement is also compatible with existing drums and bit holder blocks. This illustrated 3/4 inch or larger diameter ballistic shaped tip insert 40 is also longer (See Fig. 6) in overall length than the 0.565 inch diameter prior insert utilized.

[0016] The overall length of the 3/4 inch diameter ballistic tip insert is about 1-1/8 inches. This length when mounted in the cylindrical recess 14, having a diameter of at least 0.625 inch, at the front of the bit holder body 18 allows the ballistic tip insert 13 to extend at least 5/8 inch from the front of the annular tungsten carbide collar 16 and to extend at least 1/2 inch outwardly of recess 14. When coating tungsten carbide inserts with diamond, high temperature, high pressure presses are used. Making more 0.565 diameter inserts has thus far yielded slightly cheaper inserts, but applicant has found that making fewer, larger inserts per manufacturing operation at cycle yields better milling results, although each insert is made at a slightly higher cost. Referring to Figs. 4 and 5, the wear pattern of a prior art PCD insert tip 25 attached to a tungsten carbide bolster bit/holder 26 of prior art 0.565 inch tip diameter is shown. The conical portion of the ballistic tip insert 25 shows some wear after substantial use of the tool. Most of the wear occurs immediately aft 27 of the widest part 28 of the tip insert. This wear occurs in the product shown on both sides in Fig. 4 and on the left (loosened material flow side in Fig. 5) in what is termed a "tungsten carbide bolster" 26 that initially is generally frustoconical in shape with a slightly convex worn outer surface. The right side of the tip 25 in Fig. 5 slides along the remaining roadway material. As shown in Figs. 4 and 5, this PCD conical front tip 25 extends minimally away from the front of the tungsten carbide bolster 26. It is submitted that the additional 5/8 inch extension of the improved 3/4 inch or larger diameter ballistic tip insert of the present disclosure urges removed asphalt and concrete material away from the tip 13 at the area of most wear (the left side of Fig. 5 in the prior art) and thus provides reduced wear on the annular ring.

[0017] Referring to Figs 2a, 2b, 2c and 2d, the bit tip insert 13 of the disclosure shown in Fig. 2b is compared with prior art 0.565 inch diameter conical tips shown in Fig. 2a. The added diamond coated conical area of the new tip 13 of Fig. 2b, shown in Fig. 2c solid line 13 at the sides of the prior art tip of Fig. 2a at 25, provides substantially greater diamond protected cutting area than the prior art. This added area, when used on neighboring like sized tips, on 5/8 inch center-to-center drums, provides substantial cutting overlap on pavement to be milled.

[0018] Figs. 2a and 2d show prior art 0.540 to 0.565 inch PCD inserts 25 which have conical PCD tips brazed to tungsten carbide bases mounted on a pick bolster 26

made of tungsten carbide.

[0019] Fig. 2c shows the outlines of tip insert 13 of the present disclosure as mounted in a bit holder with the prior art 0.565 tip and bolster of Fig. 2a superimposed at 25 thereon. As in Fig. 2b, the added (enlarged) diamond coated conical portion over this piece of prior art can readily be seen with similar advantages as discussed above. The profiles toward the top of the bit insert are similar, but the height of the tapered portion is greater than a 0.565 inch PCD tip producing better wear protection to the annular carbide ring as will be discussed below.

[0020] Fig. 2d shows another prior art 0.565 diamond tip insert 25. Applicant's 0.75 inch conical tip insert would provide similar advantages over this tip as mentioned in connection with Fig. 2c above.

[0021] Fig. 3 shows a second embodiment of a bit/holder 30 of the present disclosure utilizing a 0.75 inch nominal diameter diamond covered conical tip 31 with a tungsten carbide base 32 that is slightly reverse tapered at its sides 33, 34 at approximately a 2 degree half angle in this illustrated embodiment, that is, 2 degrees per side. In other embodiments, the tungsten carbide base 32 is slightly reverse tapered at its sides 33, 34 in the range of and including 1/100 of 1 degree to 15 degrees per side).

[0022] While prior art bits and bit/holders disclose an enlarged tungsten carbide conical portion just aft of the 0.565 inch base insert with PCD shaped tip, the present disclosure, having a steel annular tubular column 35 having a recess 37 (Fig. 3) into which the 0.75 diameter PCD insert 31 is inserted, provides additional shock absorbing characteristics as a result of the ductility of the steel and subjacent braze joint. Prior art PCD tungsten carbide inserts brazed to tungsten carbide bases do not possess those shock absorbing capabilities. The central steel annular tubular column 35 also provides for greater thermal expansion and contraction during use. As the forward end of the PCD insert 31 increases its working temperature, the steel column 35 and the braze joint will expand about twice the amount of tungsten carbide expansion for the same increase in temperature and radially grab the PCD insert 31 more securely. The carbide collar 36 restricts the steel column 35 from similarly expanding outwardly. The steel tubular column 35 has about twice the coefficient rate of thermal expansion value as tungsten carbide.

[0023] Thus, improved bit/holders 10, 30, utilizing a ballistic shape tip of an increased diameter from 0.565 inch to 0.75 inch and larger provides a superior product than previously known in the art while still being usable with present size bit holder blocks (not shown).

[0024] Referring to Fig. 6, a third embodiment of a ballistic shaped diamond coated tungsten carbide insert 40 is shown. A tip such as shown in the first embodiment could include a frustoconical tip having an approximately 1/8 inch curved radius at the top 41 thereof, and straight or parabolic conical sides leading down to the widest part of the base 44. Also, the tip 13 shown in the first embodiment has a cylindrical base 13a that extends at least

about 3/4 inch behind the generally conical tip 13, which fits into the cylindrical recess 14 at the top of the body 18 of the holder 10 in the first embodiment and is brazed into recess 14.

[0025] In the second embodiment of the bit/holder 30, the tip 31 shown in Fig. 3 and the third embodiment of the tip 40 of Fig. 6 also include an approximate 1/8 inch curved top. The sides 31a, 31b (Fig. 3) of the conical portion of the insert are parabolic in shape. An additional 1/8 inch thereafter, the parabola shape changes to a 60-1/2 degree separation and another 1/8 inch down from there the separation changes to an approximate 51 degree separation.

[0026] The parabolic shape of the ballistic tip 31 provides more mass under the multi layered diamond coating than would a straight side conical tip. Additionally, the top of the parabolic tip 31 provides improved separation of the material removed from the base thereof and directs the material removed further away from the base of the tip.

[0027] As shown, the base 32 of the tip 31 in the second embodiment is 3/4 inch in diameter and in the second embodiment includes a 2 degree per side taper toward the bottom of the insert which is about a total 1 inch to 1.5 inches in height.

[0028] As mentioned previously, it appears from the drawing shown in Fig. 3, that an important factor for wear in the bit/holder is the width of the base of the tip in the insert. While prior art inserts have been approximately 0.565 inch in diameter, increasing that diameter to 0.75 inch and larger provides a wider base at the point of greatest wear during use of such a bit/insert. Thus the use of a 0.75 inch or greater diameter insert base provides for greater longevity of use. Also, larger bit holders are utilized for trenching and mining operations, so larger bit inserts can be utilized there. Further, the increased length of the insert to 1 inch in length or greater allows at least a 5/8 inch exposed length of the insert that also directs material removed away from the base of the insert to decrease the wear in what Figs. 4 and 5 show as the most sensitive part of the wear for a bit/holder during use.

[0029] The third embodiment of the diamond coated tip 40 shown in Fig. 6 differs from that shown in Fig. 3 in that the diamond coating 46 includes a ridge or overfill portion 44 at the base of the parabolic curves 42, 43 that has a thickness of about 0.010 inch or more per side. The overfill or over formed portion 44 may not be regular in shape and does not need to be ground or removed into any specific shape. This added diameter also affects the shape of the finished surface as will be discussed in more detail below. Depending upon the grade of diamond material or PCD material used, this thickness of the diamond coating may typically be about 0.120 inch or less. Multiple layers of diamond coating 46, 47, as shown in Fig. 6, may be overlayed on the bit tip 40. It should be noted that with the greater diameter and outward extending diamond edge overfill 44 of the increased tip 40 shown in Fig. 6, a thinner diamond or PCD coating at 46, 47 may

be utilized in adjusting wear characteristics vs. cost. It should be noted that the conical area of a 0.75 inch diameter cone at the tip includes over 3.5 times the area of a 0.565 inch tip, providing a substantially more massive cutting tool.

[0030] Referring to Figs. 7 and 8, a plurality of cutting tools 50-50, constructed in accordance with the present disclosure, are shown sweeping across the cutting area of a surface to be removed. As previously described, the increased outer diameter of the bit tip to 0.75 inch adds mass to the exact area where most wear during use occurs. This increased cross section creates a shallow depth pattern as needed in micro milling, without requiring additional machine horsepower.

[0031] As previously discussed, a plurality of these bit assemblies 50-50 are mounted on cylindrical drum 51 in spiral or chevron fashion. A typical drum being about 7 feet to about 13 feet in length and typically 42 to 54 inches in diameter, may hold around 168 to 650 bit assemblies with center-to-center axial spacing of 0.625 inch between bit assemblies. This is in what is termed a "standard drum" previously used for removal of not only surface material, but also substrate material. Previously, drums used for micro milling have had center-to-center tip axial spacing of 0.20 inch between tips. As such, drums used for micro milling may have about 325 bit assemblies for same 7 feet 2 inch length drum. This is in drums term "double or triple hit drums," double hit drums may have about 25 percent more of the bit assemblies. Full lane micro milling drums that are about 13 feet in length may have 600 to 900 bit assemblies per drum at a 0.200 inch center-to-center axial tip spacing.

[0032] Applicant has found that the use of 3/4 inch nominal diameter or larger diamond coated bit tips when used at 1/2 to 1 inch depth of cut at approximately 92 rpm drum rotation speed and at a travelling speed of 20-40 ft/min may provide a surface approaching or equal to the flatness of a micro milled surface previously obtained with 0.565 inch diameter bit tips on drums having 0.200 inch center-to-center bit separation with same machine cutting specifications.

[0033] Fig. 8 shows a diagram of succeeding 0.75 inch bit tips of the present disclosure spaced at 0.625 inch apart which gives an axial overlap between adjacent bit tips of about 0.125 inch. This overlap is also at the point of most vertical curvature for even a 1/2 inch depth of the cut, leaving a substantially flatter surface than would be obtained using the 0.565 inch diameter bit tips. The fineness of the residual surface is also obtained by moving the drum at a slower speed (15-25 fpm). The faster in feet per minute the drum travels forward, the rougher the cut. It is therefore necessary not to outrun the cut. A speed of 60-120 feet per minute is considered normal for a rough cut.

[0034] As noted, the resulting fineness of the surface milled using the larger diameter bit tip approaches or achieves micro milling flatness by utilizing standard center-to-center diameter drums instead of the more expen-

sive drums presently made for micro milling operations. Additional fineness of cut can be achieved by modifying spacing to somewhat less than 0.625, but substantially greater than 0.2 inch center-to-center. Not only is the cost of the drum less, but utilizing fewer bit assemblies makes a lighter drum requiring less horsepower to operate with more fuel efficiency and less impact on the machine components.

[0035] Referring to Figs. 9 and 10, a fourth embodiment of a generally conical tip insert 116, that includes a parabolic curved section below an apex of the tip insert 116, in a third embodiment of a bit/holder 60 of the present disclosure is shown. The bit/holder 60 is a unitary bit and bit holder construction that includes a body 62 and a generally cylindrical hollow shank 64 axially depending from a bottom of the body 62. The shank 64 includes an elongate first slot 66 extending from a generally annular distal end 68 of the shank 64 axially upward or forward to an upper termination 70 adjacent the upper or forward end of the shank 64. In this embodiment, the shank 64 also includes an internally oriented second slot 72 located approximately 180 degrees around the annular shank 64 from the first slot 66. This second slot 72 is parallel to the first slot 66 and is an internal slot having a rearward semicircular termination 74 inwardly adjacent to the distal end 68 of the shank 64 and a forward semicircular termination 76 (not shown) generally coinciding longitudinally and axially with the upper termination 70 of the first slot 66.

[0036] In this illustrated embodiment, the shank 64 preferably includes a lower or first tapered portion 78 running axially from a stepped shoulder 80 adjacent the distal end 68 of the shank 64. The stepped shoulder 80 is disposed between the lower tapered portion 78 and the distal end 68. A diameter of the stepped shoulder 80 increases, or steps up, as it axially extends from the distal end 68 to the lower tapered portion 78. The first tapered portion 78 runs upwardly or axially from the stepped shoulder 80 of the shank 64 and terminates generally mid slot 66 longitudinally. The shank 64 also includes an annular shoulder 82 separating the lower tapered portion 78 from an upper or second tapered portion 84 which extends from the shoulder 82 to generally adjacent to the top of the shank 64 or forward terminations 70, 76 of slots 66, 72, respectively. The annular shoulder 82 is disposed between the lower tapered portion 78 and the upper tapered portion 84. A diameter of the annular shoulder 82 decreases, or steps down, as it axially extends from the lower tapered portion 78 to the upper tapered portion 84. A generally cylindrical top portion 86 of the shank 64 extends from a position adjacent the top or upper terminations 70, 76 of slots 66, 72, respectively, towards a generally annular back flange 88 that denotes the base or bottom of the body 62 of the bit/holder 60. The top of the shank 64 may include a rounded junction 87 between the top portion 86 of the shank 64 and the generally annular flange 88 of the body 62 of the bit/holder 60, which is provided to avoid sharp corners which may provide an area for stress cracks to begin.

[0037] The generally annular flange 88 includes a pair of horizontal slots 90-90 generally perpendicular to the longitudinal axis of the combination bit/bit holder, one on either side of the generally annular flange 88. The horizontal slots 90-90 are configured to receive a pair of bifurcated fork tines that may be inserted between the base of the body 62 of the bit/holder 60 and a base block (not shown) into which the shank 64 of the bit/holder combination is inserted and retained by outward radial force in use.

[0038] A central bore 100 longitudinally and axially extending through the shank 64 of the bit holder body 62 of the bit/holder 60 combination terminates at bore termination 102, which in this illustrated embodiment has a conical shape, which is approximately at the upper end of the shank 64. This allows the generally C-shaped annular side wall of the shank 64 to radially contract when the shank 64 is mounted in a tapered or cylindrical bore in a base block (not shown).

[0039] In this third illustrated embodiment of the bit/holder 60, the bit holder body 62 includes an generally cylindrical or annular upper body portion 92 depending from a forward end 94 of the upper body portion 92. Optionally, a mid-section of the upper body portion 92 of the bit/holder 60 may include a cross or through hole 93 substantially perpendicular to the longitudinal axis of the bit/holder 60. This cross hole 93 extends horizontally through the upper body portion 92 and forms a receiver for a drift pin (not shown) used in connection with the cup portion of a bit/holder insertion tool. In an alternate embodiment, the upper body portion 92 of the bit/holder 60 may not include a cross or through hole. A mediate body portion 96 subjacent the upper body portion 92 generally slopes axially and radially outwardly to a radially extending generally arcuate tire portion 98.

[0040] The bit holder body 62, in order to provide superior brazing of a tungsten carbide ring 110 to the forward end 94 of the upper body portion 92, includes a forwardly extending annular collar 104 that is created on the bit holder body 62 to provide an annular trough 106 around a tapered forward extension 108 of the bit holder body 62 onto which the annular ring 110 is mounted. In this illustrated embodiment, the annular collar 104 includes a cylindrical bottom inner wall 105 and a tapered top inner wall or countersink 107. The vertical outer wall of the trough 106 will keep brazing material from flowing outwardly of the joint between the base of the ring 110 and the annular trough 106 on which the ring 110 is positioned. The annular trough 106 is therearound positioned perpendicular to the axis of the bit/holder 60 from the interior of which axially extends the smaller radially oriented annular tapered upper or forward extension 108. Around this tapered forward extension 108 is fitted the annular tungsten carbide ring 110, seated in the annular trough 106, which may preferably be braised into unitary construction with the remainder of the bit/holder 60. The top or forwardmost portion of the tungsten carbide ring 110 and the annular tapered forward extension 108 of

the upper body portion terminate generally at a forward end 95 of the bit holder body 62 of the combination bit/holder 60.

[0041] With the bit holder body 62 of the present disclosure preferably made of 4340 or equivalent steel, the top of the forward extension 108 of the upper body 92 includes a radially declining tapered bore 112, or a generally cylindrical bore in other embodiments, extending from the co-terminal upper wall of the body axially inwardly thereof which defines, in this illustrated embodiment, a radially declining taper. In other embodiments, the bore can also have a hollow generally cylindrical shape or a slight draw or draft angle. The bore 112 extends a short distance longitudinally axially inwardly of the forward extension 108 to define a base 111 for the tip insert base 114. The base 111, in this illustrated embodiment, has a tapered shape. The bit holder body 62 also includes a bore 115 that axially extends from the base 111 of the bore 112 to a bore termination 117, which in this embodiment is conical shaped, within the upper body portion 92 of the bit/holder 60 adjacent the annular trough 106.

[0042] The tapered bore 112 provides a space for receiving a complementary shaped declining tapered outer surface 113 of the base 114 of the tip insert 116 for the bit/holder combination. In one exemplary implementation of the fourth embodiment, the tip insert 116 can have a diameter in the range of 5/8 inch to 1.250 inch. In this fourth embodiment, the base 114 includes a tapered portion 120 adjacent a distal end 122 of the base 114. The base 114 may be made of steel or tungsten carbide and includes a tip 118 at an outer or forward end 124 of the base 114. In this embodiment, an outer surface or forward end 126 of tip 118 has an overlay 127 of a polycrystalline diamond structure. The tip 118 can have a frustoconical shape, a flat generally cylindrical puck shape, a parabolic ballistic shape, and/or an arcuate shape. The outer surface 126 of the tip 118 may also include an overlay 127 of an industrial diamond material and may be a single coating or outer layer or multiple coating or outer layers of such industrial diamond material, natural diamond, polycrystalline diamond (PCD) material, and polycrystalline diamond composite or compact (PDC) material. The single or multiple coatings or layers may be formed by a high pressure, high temperature process. The overlay 127 occupies a large radial and axial profile of the tip 118 which allows faster heat transfer into a region subjacent to the overlay 127 PCD layer. Excessively high heat, such as temperatures above 1300 degrees F, is the greatest cause of PCD failure due to diamond connective failure, the quick heat transfer from the tip 118 of the PCD cutting zone, which is approximately 1/2 inch depth of cut per tip engagement, to the subjacent region below the PCD drastically reduces the possibility of a temperature of the tip 118 of the PCD reaching temperatures at or above 1300 degrees F for any extended period of time thereby avoiding failure of the PCD layer.

[0043] The tip insert 116 further includes a bore 119

that axially extends from the distal end 122 of the tip insert 116 to a bore termination 121, which in this embodiment has a rounded shape, within the tip 118 adjacent an apex thereof. In this illustrated embodiment, the bore termination 121 is approximately a minimum distance 128 (Fig. 10), which maybe approximately 3/16 inch, from the apex of the tip 118. The bore 115 and the bore 119 are adapted to receive an insert 123 made of a high heat transfer of conductor material, such as copper in this illustrated embodiment. The bore 115, the bore 119, and the insert 123 can vary in diameter 129 (Fig. 10) depending on the size of the tip insert 116. A depth 125 (Fig. 10) that the insert 123 axially extends into the upper body portion 92 of the bit/holder 60 is sufficient to transfer and/or disperse heat from the overlay 127.

[0044] Referring to Figs. 11 and 12, a fifth embodiment of a generally conical tip insert 216, that includes a parabolic curved section below an apex of the tip insert 216, in a fourth embodiment of a bit/holder 160 of the present disclosure is shown. The bit/holder 160 is a unitary bit and bit holder construction that includes a body 162 and a generally cylindrical hollow shank 164 axially depending from a bottom of the body 162. The shank 164 includes an elongate first slot 166 extending from a generally annular distal end 168 of the shank 164 axially upward or forward to an upper termination 170 adjacent the upper or forward end of the shank 164. In this embodiment, the shank 164 also includes an internally oriented second slot 172 (Fig. 12) located approximately 180 degrees around the annular shank 164 from the first slot 166. This second slot 172 is parallel to the first slot 166 and is an internal slot having a rearward semicircular termination 174 (Fig. 12) inwardly adjacent to the distal end 168 of the shank 164 and a forward semicircular termination 176 (not shown) generally coinciding longitudinally and axially with the upper termination 170 of the first slot 166.

[0045] In this illustrated embodiment, the shank 164 preferably includes a lower or first tapered portion 178 running axially from a stepped shoulder 180 adjacent the distal end 168 of the shank 164. The stepped shoulder 180 is disposed between the lower tapered portion 178 and the distal end 168. A diameter of the stepped shoulder 180 increases, or steps up, as it axially extends from the distal end 168 to the lower tapered portion 178. The first tapered portion 178 runs upwardly or axially from the stepped shoulder 180 of the shank 164 and terminates generally mid slot 166 longitudinally. The shank 164 also includes an annular shoulder 182 separating the lower tapered portion 178 from an upper or second tapered portion 184 which extends from the shoulder 182 to generally adjacent to the top of the shank 164 or forward terminations 170, 176 of slots 166, 172, respectively. The annular shoulder 182 is disposed between the lower tapered portion 178 and the upper tapered portion 184. A diameter of the annular shoulder 182 decreases, or steps down, as it axially extends from the lower tapered portion 178 to the upper tapered portion 184. A generally cylin-

dricial top portion 186 of the shank 164 extends from a position adjacent the top or upper terminations 170, 176 of slots 166, 172, respectively, towards a generally annular back flange 188 that denotes the base or bottom of the body 162 of the bit/holder 160. The top of the shank 164 may include a rounded junction 187 between the top portion 186 of the shank 164 and the generally annular flange 188 of the body 162 of the bit/holder 160, which is provided to avoid sharp corners which may provide an area for stress cracks to begin.

[0046] The generally annular flange 188 includes a pair of horizontal slots 190-190 (Fig. 12) generally perpendicular to the longitudinal axis of the combination bit/bit holder, one on either side of the generally annular flange 188. The horizontal slots 190-190 are configured to receive a pair of bifurcated fork tines that may be inserted between the base of the body 162 of the bit/holder 160 and a base block (not shown) into which the shank 164 of the bit/holder combination is inserted and retained by outward radial force in use.

[0047] A central bore 200 longitudinally and axially extending through the shank 164 of the bit holder body 162 of the bit/holder 160 combination terminates at bore termination 202, which in this illustrated embodiment has a conical shape, that is approximately at the upper end of the shank 164. This allows the generally C-shaped annular side wall of the shank 164 to radially contract when the shank 164 is mounted in a tapered or cylindrical bore in a base block (not shown).

[0048] In this fourth illustrated embodiment of the bit/holder 160, the bit holder body 162 includes a generally cylindrical or annular upper body portion 192 depending from a forward end 194 of the upper body portion 192. Optionally, a mid-section of the upper body portion 192 of the bit/holder 160 may include a cross or through hole 193 substantially perpendicular to the longitudinal axis of the bit/holder 160. This cross hole 193 extends horizontally through the upper body portion 192 and forms a receiver for a drift pin (not shown) used in connection with the cup portion of a bit/holder insertion tool. In an alternate embodiment, the upper body portion 192 of the bit/holder 160 may not include a cross or through hole. A mediate body portion 196 subjacent the upper body portion 192 generally slopes axially and radially outwardly to a radially extending generally arcuate tire portion 198.

[0049] The bit holder body 162, in order to provide superior brazing of a tungsten carbide ring 210 to the forward end 194 of the upper body portion 192, includes a forwardly extending annular collar 204 that is created on the bit holder body 162 to provide an annular trough 206 around a tapered forward extension 208 of the bit holder body 162 onto which the annular ring 210 is mounted. In this illustrated embodiment, the annular collar 204 includes a cylindrical bottom inner wall 205 and a tapered top inner wall or countersink 207. The vertical outer wall of the trough 206 will keep brazing material from flowing outwardly of the joint between the base of the ring 210

and the annular trough 206 on which the ring 210 is positioned. The annular trough 206 is therearound positioned perpendicular to the axis of the bit/holder 160 from the interior of which axially extends the smaller radially oriented annular tapered upper or forward extension 208. Around this tapered forward extension 208 is fitted the annular tungsten carbide ring 210, seated in the annular trough 206, which may preferably be braised into unitary construction with the remainder of the bit/holder 160. The top or forwardmost portion of the tungsten carbide ring 210 and the annular tapered forward extension 208 of the upper body portion terminate generally at a forward end 195 of the bit holder body 162 of the combination bit/holder 160.

[0050] With the bit holder body 162 of the present disclosure preferably made of 4340 or equivalent steel, the top of the forward extension 208 of the upper body 192 includes a radially declining tapered bore 212, or a generally cylindrical bore in other embodiments, extending from the co-terminal upper wall of the body axially inwardly thereof which defines, in this illustrated embodiment, a radially declining taper. In other embodiments, the bore can also have a hollow generally cylindrical shape or a slight draw or draft angle. The bore 212 extends a short distance longitudinally axially inwardly of the forward extension 208 to define a base 211 for the tip insert base 214. The base 211, in this illustrated embodiment, has a conical shape.

[0051] The tapered bore 212 provides a space for receiving a complementary shaped declining tapered outer surface 213 of the base 214 of the tip insert 216 for the bit/holder combination. In one exemplary implementation of the fifth embodiment, the tip insert 216 can have a diameter in the range of 5/8 inch to 1.250 inch. In this fifth embodiment, the base 214 includes a tapered portion 220 adjacent a distal end 222 of the base 214. The base 214 may be made of steel or tungsten carbide and includes a tip 218 at an outer or forward end 224 of the base 214. In this embodiment, an outer surface or forward end 226 of tip 218 has an overlay 227 (Fig. 11) of a polycrystalline diamond structure. The tip 218 can have a frustoconical shape, a flat generally cylindrical puck shape, a parabolic ballistic shape, and/or an arcuate shape. The outer surface 226 of the tip 218 may also include an overlay 227 of an industrial diamond material and may be a single coating or outer layer or multiple coating or outer layers of such industrial diamond material, natural diamond, polycrystalline diamond (PCD) material, and polycrystalline diamond composite or compact (PDC) material. The single or multiple coatings or layers may be formed by a high pressure, high temperature process. The overlay 227 occupies a large radial and axial profile of the tip 218 which allows faster heat transfer into a region subjacent to the overlay 227 PCD layer. Excessively high heat, such as temperatures above 1300 degrees F, is the greatest cause of PCD failure due to diamond connective failure, the quick heat transfer from the tip 218 of the PCD cutting zone, which is approxi-

mately 1/2 inch depth of cut per tip engagement, to the subjacent region below the PCD drastically reduces the possibility of a temperature of the tip 218 of the PCD reaching temperatures at or above 1300 degrees F for any extended period of time thereby avoiding failure of the PCD layer.

[0052] The tip insert 216 further includes a bore 228 that axially extends from the distal end 222 of the tip insert 216 to a bore termination 230, which in this embodiment has a rounded shape, within the tip 218 adjacent an apex thereof. The bore 228 is adapted to receive diamond particles 232 that may be brazed, packed firmly, bonded with epoxy, or the like, into the bore 228 and distribute heat generated at the cutting tip 118. The diamond particles 232 are sealed within bore 228 by a metal plug 234 that is placed in a space 229 (Fig. 12) within bore 228 adjacent the distal end 222 of the base 214.

[0053] Referring to Fig. 13, a sixth embodiment of a generally conical tip insert 316, that includes a parabolic curved section below an apex of the tip insert 316, in a fifth embodiment of a bit/holder 260 of the present disclosure is shown. The bit/holder 260 is a unitary bit and bit holder construction that includes a body 262 and a generally cylindrical hollow shank 264 axially depending from a bottom of the body 262. The shank 264 includes an elongate first slot 266 extending from a generally annular distal end 268 of the shank 264 axially upward or forward to an upper termination 270 adjacent the upper or forward end of the shank 264. In this embodiment, the shank 264 also includes an internally oriented second slot 272 located approximately 180 degrees around the annular shank 264 from the first slot 266. This second slot 272 is parallel to the first slot 266 and is an internal slot having a rearward semicircular termination 274 inwardly adjacent to the distal end 268 of the shank 264 and a forward semicircular termination 276 (not shown) generally coinciding longitudinally and axially with the upper termination 270 of the first slot 266.

[0054] In this illustrated embodiment, the shank 264 preferably includes a lower or first tapered portion 278 running axially from a stepped shoulder 280 adjacent the distal end 268 of the shank 264. The stepped shoulder 280 is disposed between the lower tapered portion 278 and the distal end 268. A diameter of the stepped shoulder 280 increases, or steps up, as it axially extends from the distal end 268 to the lower tapered portion 278. The first tapered portion 278 runs upwardly or axially from the stepped shoulder 280 of the shank 264 and terminates generally mid slot 266 longitudinally. The shank 264 also includes an annular shoulder 282 separating the lower tapered portion 278 from an upper or second tapered portion 284 which extends from the shoulder 282 to generally adjacent to the top of the shank 264 or forward terminations 270, 276 of slots 266, 272, respectively. The annular shoulder 282 is disposed between the lower tapered portion 278 and the upper tapered portion 284. A diameter of the annular shoulder 282 decreases, or steps down, as it axially extends from the lower tapered portion

278 to the upper tapered portion 284. A generally cylindrical top portion 286 of the shank 264 extends from a position adjacent the top or upper terminations 270, 276 of slots 266, 272, respectively, towards a generally annular back flange 288 that denotes the base or bottom of the body 262 of the bit/holder 260. The top of the shank 264 may include a rounded junction 287 between the top portion 286 of the shank 264 and the generally annular flange 288 of the body 262 of the bit/holder 260, which is provided to avoid sharp corners which may provide an area for stress cracks to begin.

[0055] The generally annular flange 288 includes a pair of horizontal slots 290-290 generally perpendicular to the longitudinal axis of the combination bit/bit holder, one on either side of the generally annular flange 288. The horizontal slots 290-290 are configured to receive a pair of bifurcated fork tines that may be inserted between the base of the body 262 of the bit/holder 260 and a base block (not shown) into which the shank 264 of the bit/holder combination is inserted and retained by outward radial force in use.

[0056] A central bore 300 longitudinally and axially extending through the shank 264 of the bit holder body 262 of the bit/holder 260 combination terminates at bore termination 302, which in this illustrated embodiment has a conical shape, which is approximately at the upper end of the shank 264. This allows the generally C-shaped annular side wall of the shank 264 to radially contract when the shank 264 is mounted in a tapered or cylindrical bore in a base block (not shown).

[0057] In this fifth illustrated embodiment of the bit/holder 260, the bit holder body 262 includes a generally cylindrical or annular upper body portion 292 depending from a forward end 294 of the upper body portion 292. Optionally, a mid-section of the upper body portion 292 of the bit/holder 260 may include a cross or through hole 293 substantially perpendicular to the longitudinal axis of the bit/holder 260. This cross hole 293 extends horizontally through the upper body portion 292 and forms a receiver for a drift pin (not shown) used in connection with the cup portion of a bit/holder insertion tool. In an alternate embodiment, the upper body portion 292 of the bit/holder 260 may not include a cross or through hole. A mediate body portion 296 subjacent the upper body portion 292 generally slopes axially and radially outwardly to a radially extending generally arcuate tire portion 298.

[0058] The bit holder body 262, in order to provide superior brazing of a tungsten carbide ring 310 to the forward end 294 of the upper body portion 292, includes a forwardly extending annular collar 304 that is created on the bit holder body 262 to provide an annular trough 306 around a tapered forward extension 308 of the bit holder body 262 onto which the annular ring 310 is mounted. In this illustrated embodiment, the annular collar 304 includes a cylindrical bottom inner wall 305 and a tapered top inner wall or countersink 307. The vertical outer wall of the trough 306 will keep brazing material from flowing

outwardly of the joint between the base of the ring 310 and the annular trough 306 on which the ring 310 is positioned. The annular trough 306 is therearound positioned perpendicular to the axis of the bit/holder 260 from the interior of which axially extends the smaller radially oriented annular tapered upper or forward extension 308. Around this tapered forward extension 308 is fitted the annular tungsten carbide ring 310, seated in the annular trough 306, which may preferably be braised into unitary construction with the remainder of the bit/holder 260. The top or forwardmost portion of the tungsten carbide ring 310 and the annular tapered forward extension 308 of the upper body portion terminate generally at a forward end 295 of the bit holder body 262 of the combination bit/holder 260.

[0059] With the bit holder body 262 of the present disclosure preferably made of 4340 or equivalent steel, the top of the forward extension 308 of the upper body 292 includes a radially declining tapered bore 312, or a generally cylindrical bore in other embodiments, extending from the co-terminal upper wall of the body axially inwardly thereof which defines, in this illustrated embodiment, a radially declining taper. In other embodiments, the bore can also have a hollow generally cylindrical shape or a slight draw or draft angle. The bore 312 extends a short distance longitudinally axially inwardly of the forward extension 308 to define a base 311 for the tip insert base 314. The base 311, in this illustrated embodiment, has a frustoconical shape.

[0060] The tapered bore 312 provides a space for receiving a complementary shaped declining tapered outer surface 313 of the base 314 of the tip insert 316 for the bit/holder combination. In one exemplary implementation of the sixth embodiment, the tip insert 316 can have a diameter in the range of 5/8 inch to 1.250 inch. In this sixth embodiment, the base 314 includes a tapered portion 320 adjacent a distal end 322 of the base 314. The base 314 may be made of steel or tungsten carbide and includes a tip 318 at an outer or forward end 324 of the base 314. In this embodiment, an outer surface or forward end 326 of tip 318 has an overlay 327 of a polycrystalline diamond structure. The tip 318 can have a frustoconical shape, a flat generally cylindrical puck shape, a parabolic ballistic shape, and/or an arcuate shape. The outer surface 326 of the tip 318 may also include an overlay 327 of an industrial diamond material and may be a single coating or outer layer or multiple coating or outer layers of such industrial diamond material, natural diamond, polycrystalline diamond (PCD) material, and polycrystalline diamond composite or compact (PDC) material. The single or multiple coatings or layers may be formed by a high pressure, high temperature process. The overlay 327 occupies a large radial and axial profile of the tip 318 which allows faster heat transfer into a region subjacent to the overlay 327 PCD layer. Excessively high heat, such as temperatures above 1300 degrees F, is the greatest cause of PCD failure due to diamond connective failure, the quick heat transfer from the tip 318 of the PCD cutting

zone, which is approximately 1/2 inch depth of cut per tip engagement, to the subjacent region below the PCD drastically reduces the possibility of a temperature of the tip 318 of the PCD reaching temperatures at or above 1300 degrees F for any extended period of time thereby avoiding failure of the PCD layer.

[0061] The tip insert 316 further includes a bore 328 that axially extends from the distal end 322 of the tip insert 316 to a bore termination 330, which in this embodiment has a rounded shape, within the tip 318 adjacent an apex thereof. In this illustrated embodiment, the bore termination 330 is approximately a minimum distance 332, which may be approximately 3/16 inch, from the apex of the tip 318. The bore 328 is adapted to allow for inward contraction and/or movement when the overlay 327 distributes heat generated at the cutting tip 318 and transfers the heat into the base 314 during cutting operations. The bore 328 prevents less outward expansion of the tungsten carbide portion of the tip insert 316, such as the base 314 and the tip 318 subjacent the overlay 327, in the direction of the overlay 327 and thereby prevents the expanded tungsten carbide from fracturing the overlay 327 of the tip insert 316.

[0062] Referring to Figs. 14-16, a seventh embodiment of a generally conical tip insert 416, that includes a parabolic curved section below an apex of the tip insert 416, and the fifth embodiment of a bit/holder 260, as described with respect to Fig. 13 above, of the present disclosure is shown. The tip insert 416 comprises a generally conical tip 418 at a forward end 424 of a tip insert base 414. In one exemplary implementation of the seventh embodiment, the tip insert 416 can have a diameter in the range of 5/8 inch to 1.250 inch. The base 414 comprises a complementary shaped declining tapered outer surface 413 that is adapted to be mounted in the tapered bore 312 of the bit/holder 260. In this seventh embodiment, the base 414 includes a tapered portion 420 adjacent a distal end 422 of the base 414. The base 414 may be made of steel or tungsten carbide and includes a tip 418 at an outer or forward end 424 of the base 414. In this embodiment, an outer surface or forward end 426 of tip 418 has an overlay 427 of a polycrystalline diamond structure. The tip 418 can have a frustoconical shape, a flat generally cylindrical puck shape, a parabolic ballistic shape, and/or an arcuate shape. The outer surface 426 of the tip 418 may also include an overlay 427 of an industrial diamond material and may be a single coating or outer layer or multiple coating or outer layers of such industrial diamond material, natural diamond, polycrystalline diamond (PCD) material, and polycrystalline diamond composite or compact (PDC) material. The single or multiple coatings or layers may be formed by a high pressure, high temperature process. The overlay 427 occupies a large radial and axial profile of the tip 418 which allows faster heat transfer into a region subjacent to the overlay 427 PCD layer. Excessively high heat, such as temperatures above 1300 degrees F, is the greatest cause of PCD failure due to diamond connective failure, the quick heat transfer from

the tip 418 of the PCD cutting zone, which is approximately 1/2 inch depth of cut per tip engagement, to the subjacent region below the PCD drastically reduces the possibility of a temperature of the tip 418 of the PCD reaching temperatures at or above 1300 degrees F for any extended period of time thereby avoiding failure of the PCD layer.

[0063] The tip insert 416 comprises a bore 428 that axially extends from the distal end 422, shown in Fig. 15, of the tip insert 416 to a bore termination 430, which in this embodiment has a rounded shape, within the tip 418 adjacent an apex thereof. In this illustrated embodiment, the bore termination 430 is approximately a minimum distance 436 (Fig. 16), which may be approximately 1/4 inch, from the apex of the tip 418. The tip insert 416 further comprises at least one bore 432, each bore 432 extending from the tapered portion 420 of the tip insert 416 to a bore termination 434, which in this embodiment has a rounded shape, within the tip insert 416. In this illustrated embodiment, bores 432 are radially positioned from bore 428 as shown in Fig. 15. Bore 428 and bores 432 are adapted to allow for inward contraction and/or movement when the overlay 427 distributes heat generated at the cutting tip 418 and transfers the heat into the base 414 during cutting operations. Bore 428 and bores 432 prevent less outward expansion of the tungsten carbide portion of the tip insert 416, such as the base 414 and the tip 418 subjacent the overlay 427, in the direction of the overlay 427 and thereby prevents the expanded tungsten carbide from fracturing the overlay 427 of the tip insert 416.

[0064] As used in this application, the term "or" is intended to mean an inclusive "or" rather than an exclusive "or". That is, unless specified otherwise, or clear from context, "X includes A or B" is intended to mean any of the natural inclusive permutations. That is, if X includes A; X includes B; or X includes both A and B, then "X includes A or B" is satisfied under any of the foregoing instances. In addition, "X includes at least one of A and B" is intended to mean any of the natural inclusive permutations. That is, if X includes A; X includes B; or X includes both A and B, then "X includes at least one of A and B" is satisfied under any of the foregoing instances. The articles "a" and "an" as used in this application and the appended claims should generally be construed to mean "one or more" unless specified otherwise or clear from context to be directed to a singular form. Moreover, use of the term "an implementation" or "one implementation" throughout is not intended to mean the same embodiment, aspect or implementation unless described as such.

[0065] While the present disclosure has been described in connection with certain embodiments and measurements, it is to be understood that the present disclosure is not to be limited to the disclosed embodiments and measurements but, on the contrary, is intended to cover various modifications and equivalent arrangements included within the scope of the appended claims,

which scope is to be accorded the broadest interpretation so as to encompass all such modifications and equivalent structures as is permitted under the law.

5 Aspects:

[0066] It is appreciated that any of aspects 1-40 can be combined.

10 1. A bit tip insert comprising:

a body comprising a tip and a base subjacent the tip, the tip including an overlay on an outer surface of the tip; and

15 a first bore axially extending from a distal end of the body to a first bore termination adjacent the tip, the first bore adapted to allow inward contraction when the overlay transfers heat into the base during operation.

20 2. The bit tip insert of aspect 1, wherein the overlay comprises at least one of a polycrystalline diamond, industrial diamond, natural diamond, polycrystalline diamond composite material, and polycrystalline diamond compact material.

25 3. The bit tip insert of aspect 1, wherein the overlay comprises at least one of:

30 at least one coating on the outer surface of the tip; and
at least one layer on the outer surface of the tip.

35 4. The bit tip insert of aspect 3, wherein the at least one coating and at least one layer on the outer surface of the tip is formed by a high pressure high temperature (HPHT) process.

40 5. The bit tip insert of aspect 1, further comprising: a tapered portion adjacent a distal end of the base.

45 6. The bit tip insert of aspect 5, further comprising: at least one second bore extending from the tapered portion adjacent a distal end of the base, each second bore including a second bore termination adjacent the tip, and each second bore adapted to allow inward contraction when the overlay transfers heat into the base during operation.

50 7. The bit tip insert of aspect 1, wherein the base is made of at least one of steel and tungsten carbide.

55 8. The bit tip insert of aspect 1, wherein the tip comprises one of a frustoconical shape, a flat generally cylindrical puck shape, an arcuate shape, a parabolic shape, and a conical shape, at least one of the conical shape and the parabolic shape including a parabolic curved section below an apex thereof.

9. The bit tip insert of aspect 1, wherein a sidewall of the base is one of cylindrical and tapered inwardly toward a bottom of the base.
10. The bit tip insert of aspect 1, wherein a distance between the first bore termination and an apex of the tip is approximately a minimum one of 3/16 inch and 1/4 inch.
11. The bit tip insert of aspect 1, further comprising: an insert disposed within the first bore of the bit tip insert, the insert adapted to transfer heat from the bit tip insert.
12. The bit tip insert of aspect 11, wherein the insert is made of a high heat transfer material.
13. The bit tip insert of aspect 11, wherein the insert is made of copper.
14. The bit tip insert of aspect 1, further comprising: a plurality of diamond particles disposed within the first bore of the bit tip insert, the diamond particles adapted to distribute heat generated at the tip.
15. The bit tip insert of aspect 14, wherein the plurality of diamond particles are at least one of brazed in the first bore, packed firmly within the first bore, and bonded with epoxy in the first bore.
16. The bit tip insert of aspect 14, further comprising: a metal plug disposed within the first bore between the plurality of diamond particles and the distal end of the body.
17. A tool comprising:
 a body comprising a first bore extending inwardly from a forward end of the body;
 a shank extending centrally axially from a bottom of the body; and
 a bit tip insert disposed in the first bore, the bit tip insert comprising:
 a bit tip body comprising a tip and a base subjacent the tip, the tip including an overlay on an outer surface of the tip; and
 a second bore axially extending from a distal end of the bit tip body to a second bore termination adjacent the tip, the second bore adapted to allow inward contraction when the overlay transfers heat into the base during operation.
18. The tool of aspect 17, wherein the first bore is one of cylindrical and tapered inwardly.
19. The tool of aspect 17, further comprising:
 a tapered portion adjacent the distal end of the bit tip body of the bit tip insert, the tapered portion adapted to contact a portion of the first bore of the body.
20. The tool of aspect 19, further comprising:
 at least one third bore extending from the tapered portion adjacent a distal end of the base, each third bore including a third bore termination adjacent the tip, and each third bore adapted to allow inward contraction when the overlay transfers heat into the base during operation.
21. The tool of aspect 17, wherein the first bore is disposed in a forward extension adjacent the forward end of the body.
22. The tool of aspect 21, wherein the forward extension is tapered.
23. The tool of aspect 21, further comprising:
 an annular trough laterally extending from a distal end of the forward extension; and
 an annular ring disposed around the forward extension and seated in the annular trough of the body.
24. The tool of aspect 23, wherein the annular ring is made of tungsten carbide.
25. The tool of aspect 17, wherein the overlay comprises at least one of a polycrystalline diamond, industrial diamond, natural diamond, polycrystalline diamond composite material, and polycrystalline diamond compact material.
26. The tool of aspect 17, wherein a sidewall of the base is one of cylindrical and tapered inwardly toward a bottom of the base.
27. The tool of aspect 17, wherein a distance between the second bore termination and an apex of the tip is approximately a minimum of one of 3/16 inch and 1/4 inch.
28. The tool of aspect 17, further comprising:
 an insert having a first end and a second end, the first end of the insert disposed within the second bore of the bit tip insert, the insert adapted to transfer heat from the bit tip insert.
29. The tool of aspect 28, wherein the insert is made of a high heat transfer material.
30. The tool of aspect 28, wherein the insert is made of copper.
31. The tool of aspect 17, further comprising:

a plurality of diamond particles disposed within the second bore of the bit tip insert, the diamond particles adapted to distribute heat generated at the tip.

32. The tool of aspect 31, wherein the plurality of diamond particles are at least one of brazed in the second bore, packed firmly within the second bore, and bonded with epoxy in the second bore.

33. The tool of aspect 31, further comprising: a metal plug disposed within the second bore between the plurality of diamond particles and the distal end of the bit tip body.

34. The tool of aspect 28, further comprising: a third bore axially extending from a bottom of the first bore of the body to a location adjacent the bottom of the first bore; and the second end of the insert disposed within the third bore, the insert extending to the location adapted to provide a depth that sufficiently transfers high heat from the tip of the bit tip insert.

35. The bit tip insert of aspect 11, wherein the insert varies in diameter depending on the size of the bit tip insert.

36. The tool of aspect 28, wherein the insert varies in diameter depending on the size of the bit tip insert.

37. The bit tip insert of aspect 11, wherein the insert is one of solid and hollow.

38. The tool of aspect 28, wherein the insert is one of solid and hollow.

39. The bit tip insert of aspect 1, wherein the body has a diameter between at least 5/8 inch and up to and including 1-1/4 inch.

40. The tool of aspect 17, wherein the bit tip body has a diameter between at least 5/8 inch and up to and including 1-1/4 inch.

Claims

1. A bit tip insert comprising:

A bit tip body comprising a tip and a base adjacent the tip, the tip including an overlay on an outer surface of the tip; and a bit tip insert bore axially extending from a distal end of the bit tip body to a bit tip insert bore termination adjacent the tip, the bit tip insert bore adapted to allow inward contraction when the overlay transfers heat into the base during operation.

2. The bit tip insert of claim 1, wherein the overlay comprises at least one of a polycrystalline diamond, industrial diamond, natural diamond, polycrystalline diamond composite material, and polycrystalline diamond compact material.

3. The bit tip insert of claim 1, wherein the overlay comprises at least one of:

at least one coating on the outer surface of the tip; and

at least one layer on the outer surface of the tip, wherein the at least one coating and at least one layer on the outer surface of the tip is formed by a high pressure high temperature (HPHT) process.

4. The bit tip insert of claim 1, further comprising:

a tapered portion adjacent a distal end of the base, and

at least one further bore extending from the tapered portion adjacent a distal end of the base, each further bore including a further bore termination adjacent the tip, and each further bore adapted to allow inward contraction when the overlay transfers heat into the base during operation.

5. The bit tip insert of claim 1, wherein the base is made of at least one of steel and tungsten carbide, or wherein the tip comprises one of a frustoconical shape, a flat generally cylindrical puck shape, an arcuate shape, a parabolic shape, and a conical shape, at least one of the conical shape and the parabolic shape including a parabolic curved section below an apex thereof, or wherein a sidewall of the base is one of cylindrical and tapered inwardly toward a bottom of the base, or wherein a distance between the bit tip insert bore termination and an apex of the tip is approximately a minimum one of 3/16 inch and 1/4 inch.

6. The bit tip insert of claim 1, further comprising: an insert disposed within the bit tip insert bore of the bit tip insert, the insert adapted to transfer heat from the bit tip insert.

7. The bit tip insert of claim 6, wherein the insert is made of a high heat transfer material, or wherein the insert is made of copper, or wherein the insert varies in diameter depending on the size of the bit tip insert.

8. The bit tip insert of claim 1, further comprising: a plurality of diamond particles disposed within the bit tip insert bore of the bit tip insert, the diamond particles adapted to distribute heat generated at the

tip.

9. The bit tip insert of claim 8, wherein the plurality of diamond particles are at least one of brazed in the bit tip insert bore, packed firmly within the first bore, and bonded with epoxy in the first bore, or wherein the bit tip insert further comprises:
 a metal plug disposed within the bit tip insert bore between the plurality of diamond particles and the distal end of the bit tip body. 5
 10
10. The bit tip insert of claim 1, wherein the bit tip body has a diameter between at least 5/8 inch and up to and including 1-1/4 inch. 15
11. A tool comprising:
 a tool body comprising a tool body bore extending inwardly from a forward end of the tool body; a shank extending centrally axially from a bottom of the tool body; and 20
 a bit tip insert according to any of claims 1-10 disposed in the tool body bore.
12. The tool of claim 11, wherein the tool body bore is one of cylindrical and tapered inwardly, or wherein the tool further comprises:
 a tapered portion adjacent the distal end of the bit tip body of the bit tip insert, the tapered portion adapted to contact a portion of the tool body bore. 25
 30
13. The tool of claim 11, wherein the tool body bore is disposed in a forward extension adjacent the forward end of the tool body. 35
14. The tool of claim 13, wherein the forward extension is tapered, or wherein the tool further comprises:
 an annular trough laterally extending from a distal end of the forward extension; and 40
 an annular ring disposed around the forward extension and seated in the annular trough of the tool body, wherein the annular ring is made of tungsten carbide. 45
15. The tool of claim 11, further comprising:
 a further tool body bore axially extending from a bottom of the tool body bore of the tool body to a location adjacent the bottom of the tool body bore; and 50
 the second end of the insert disposed within the further tool body bore, the insert extending to the location adapted to provide a depth that sufficiently transfers high heat from the tip of the bit tip insert. 55

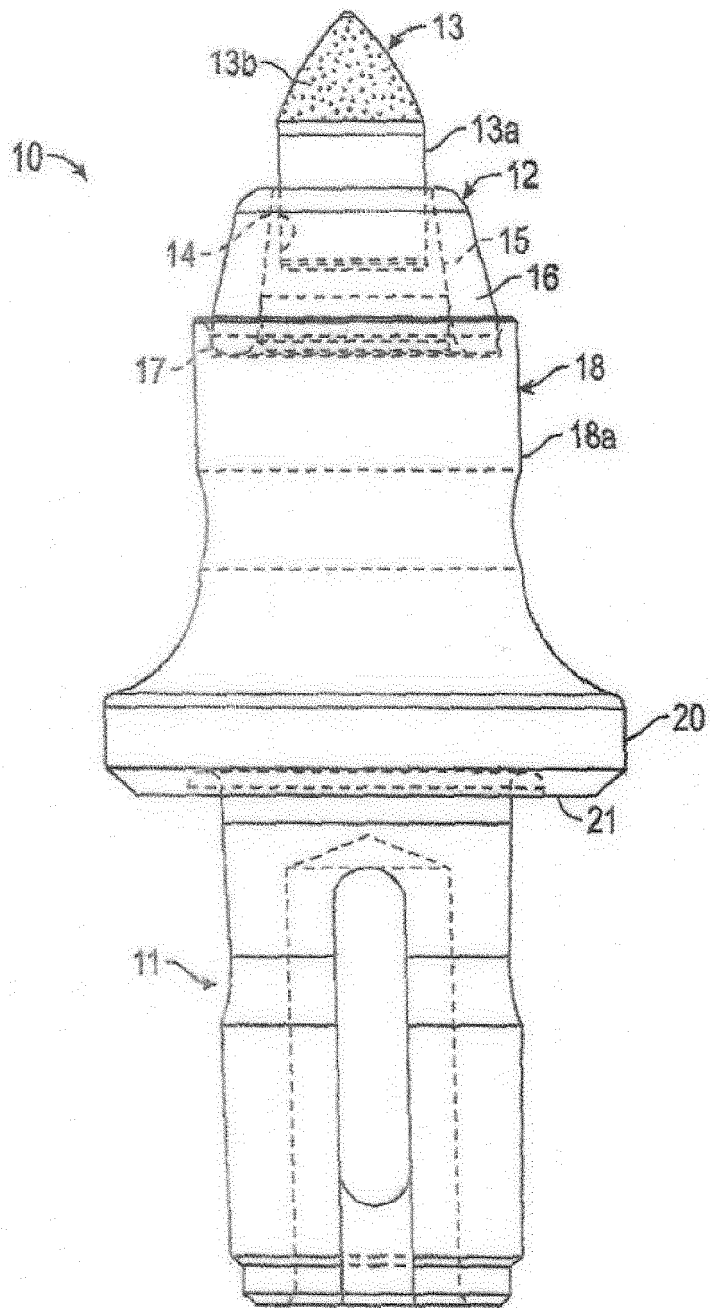

FIG. 1

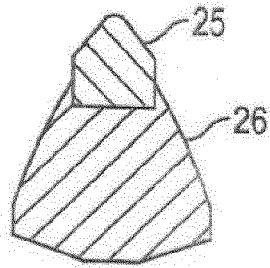

FIG. 2A
(Prior Art)

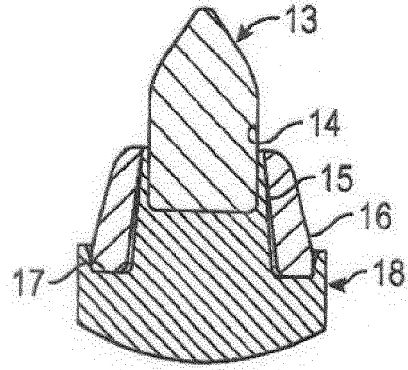

FIG. 2B

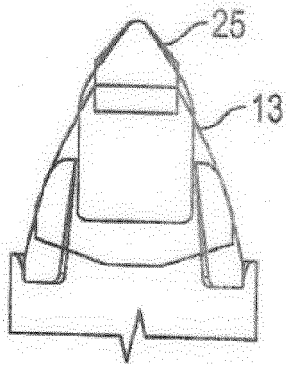

FIG. 2C

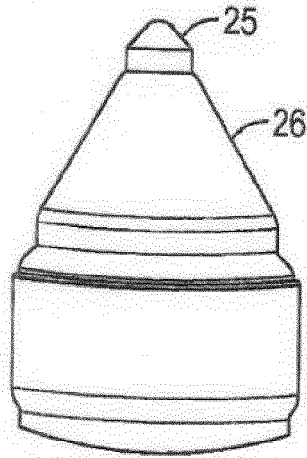

FIG. 2D
(Prior Art)

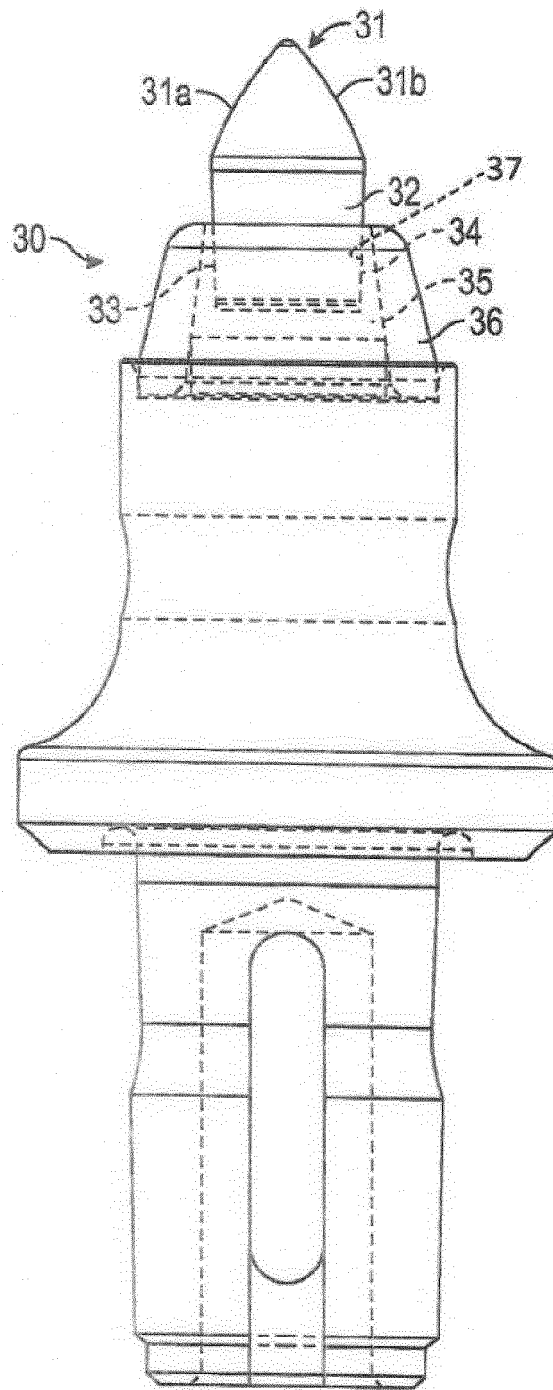

FIG. 3

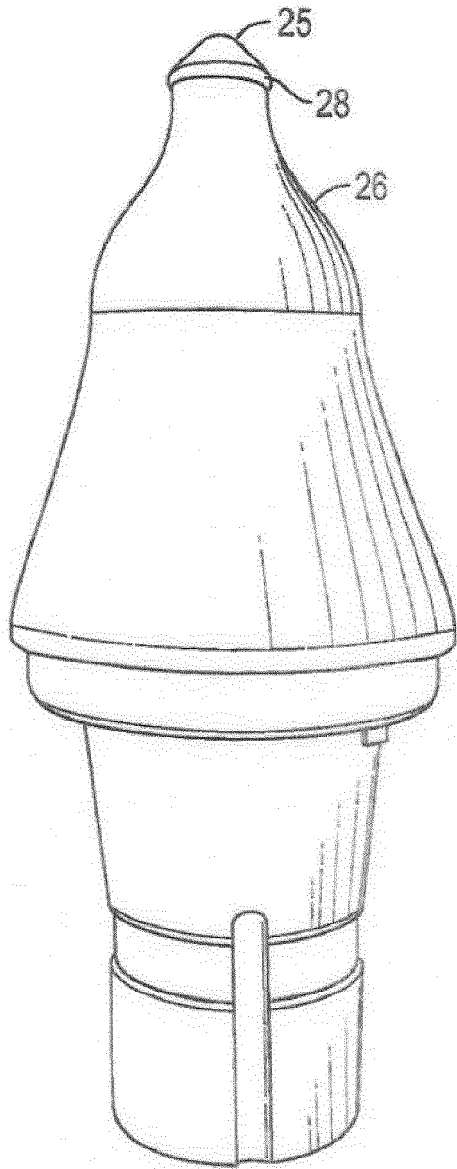

FIG. 4
(Prior Art)

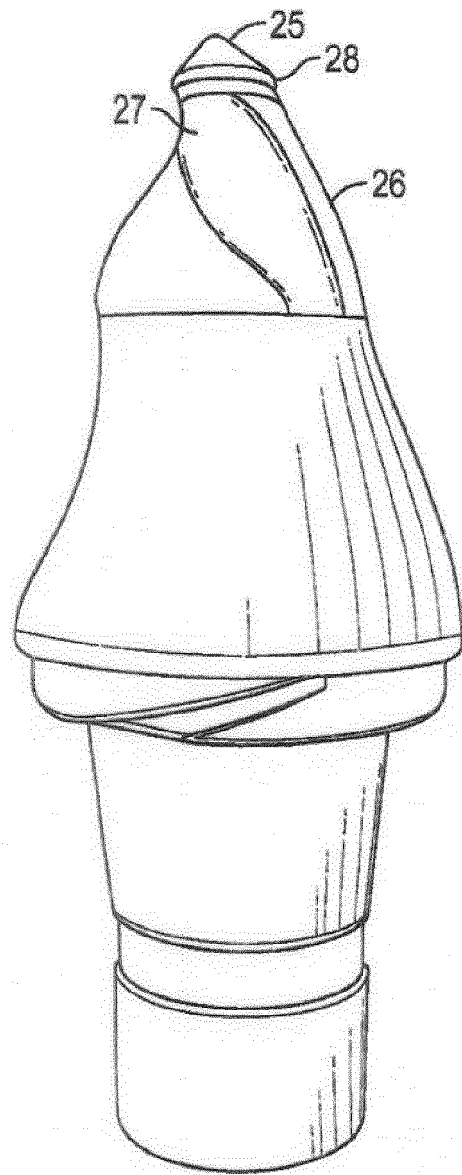

FIG. 5
(Prior Art)

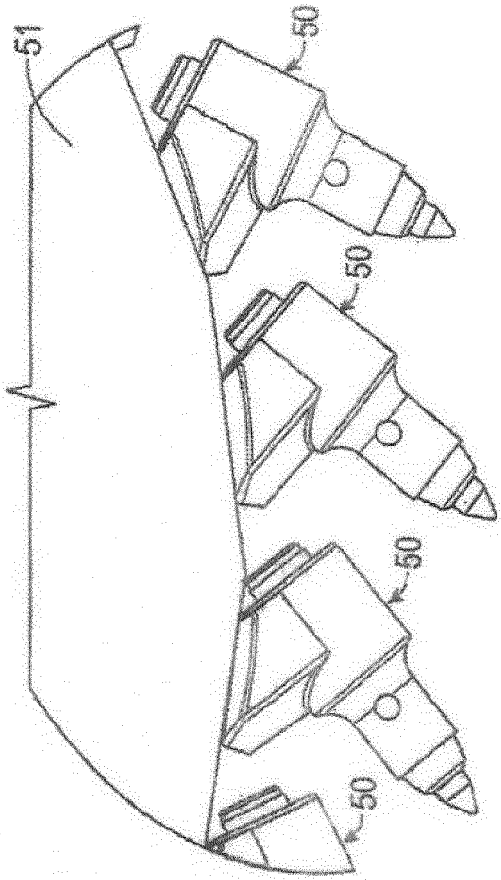

FIG. 7

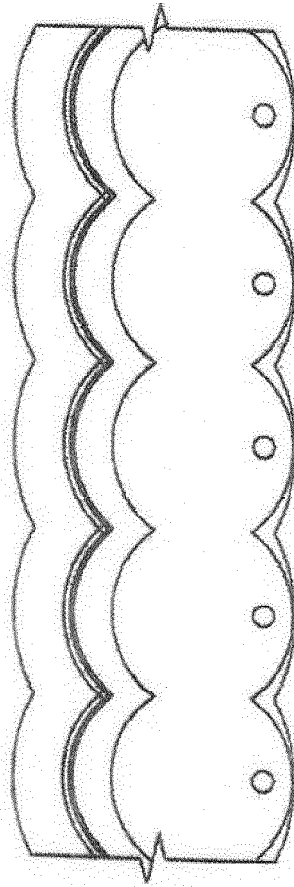

FIG. 8

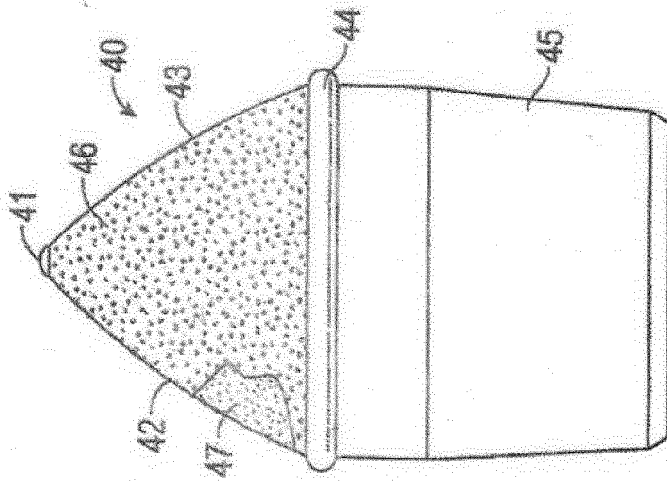

FIG. 6

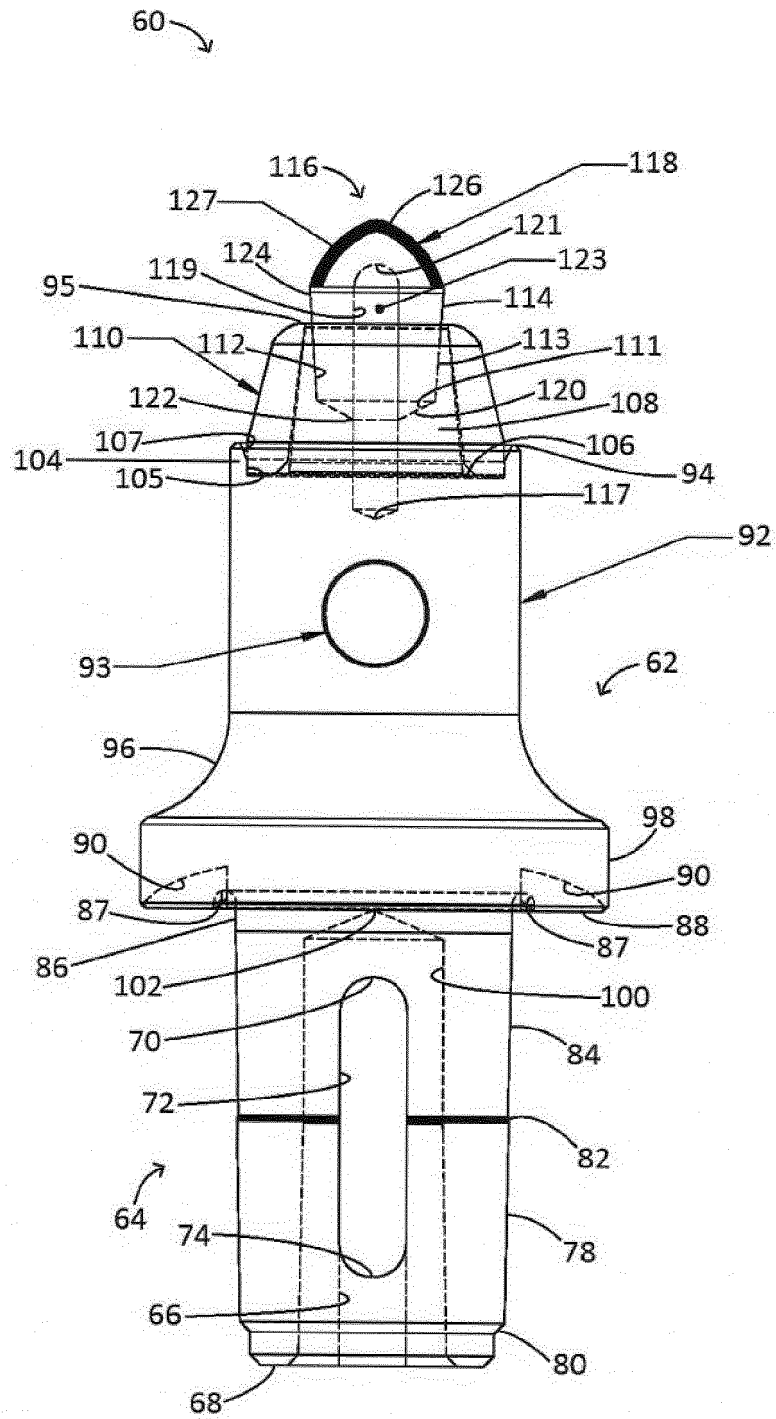

FIG. 9

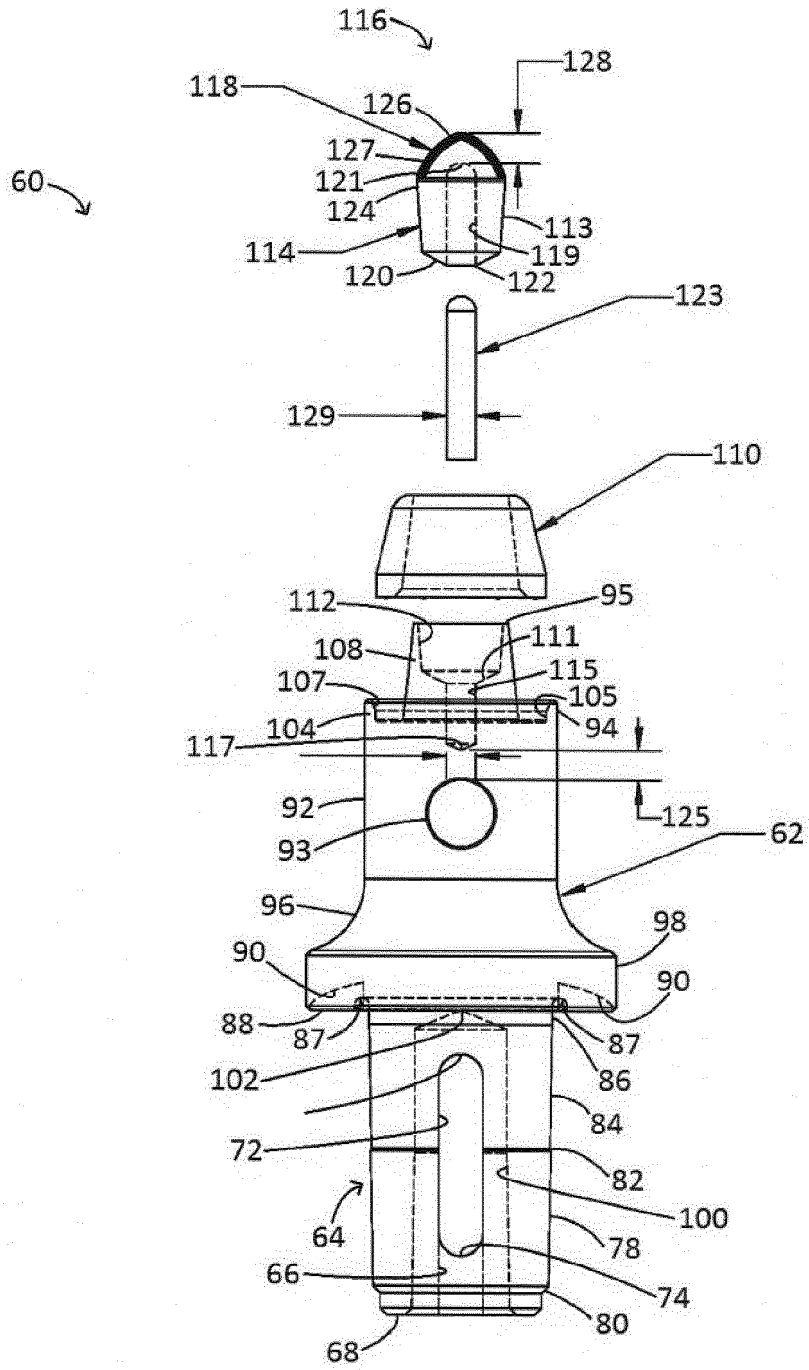

FIG. 10

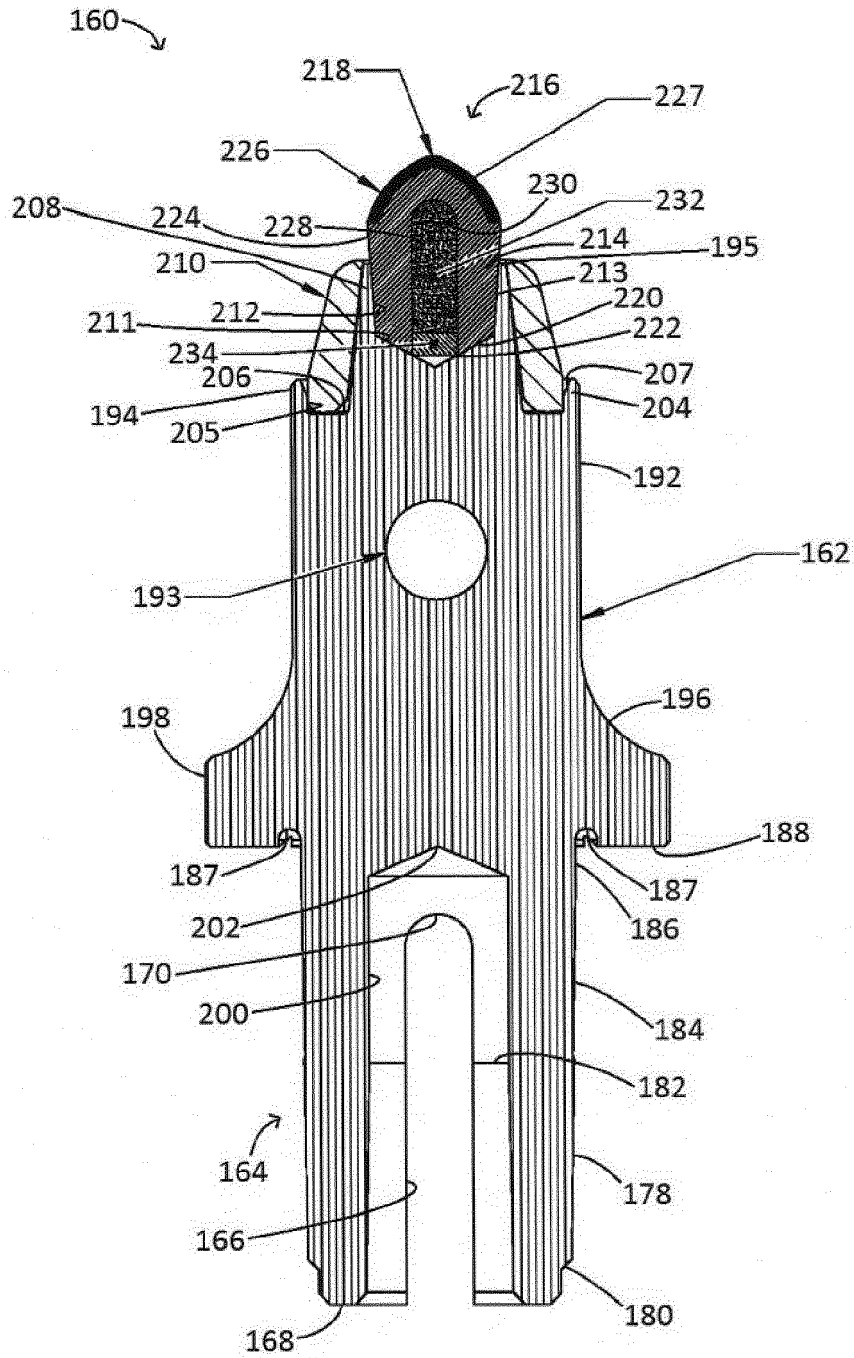

FIG. 11

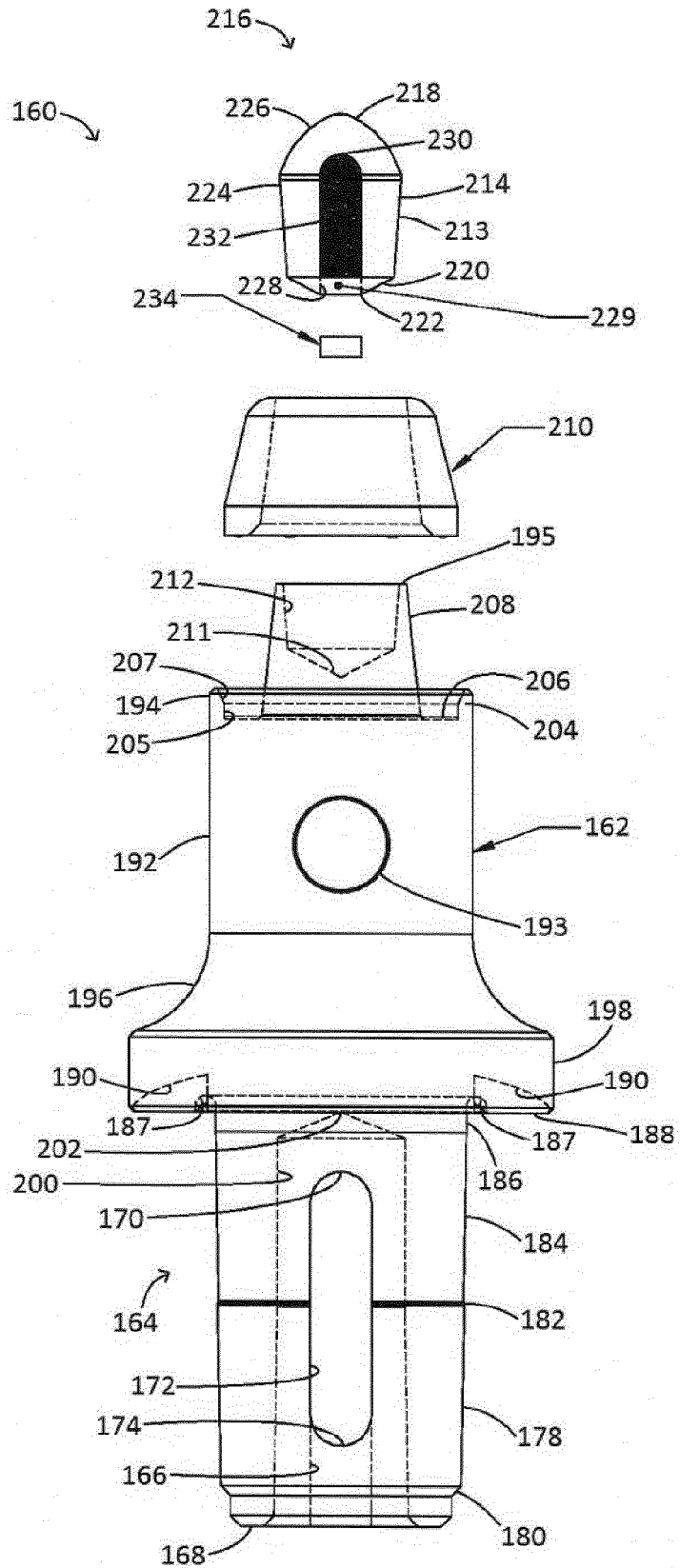

FIG. 12

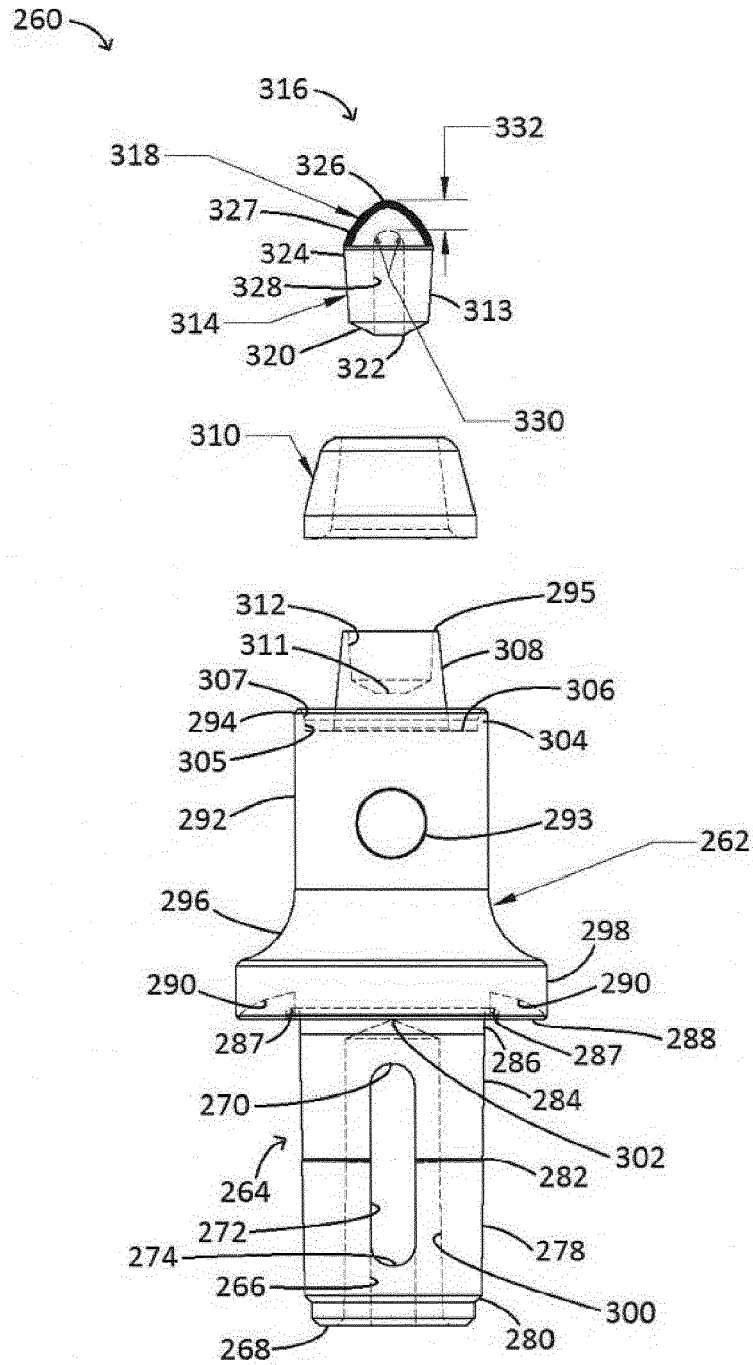

FIG. 13

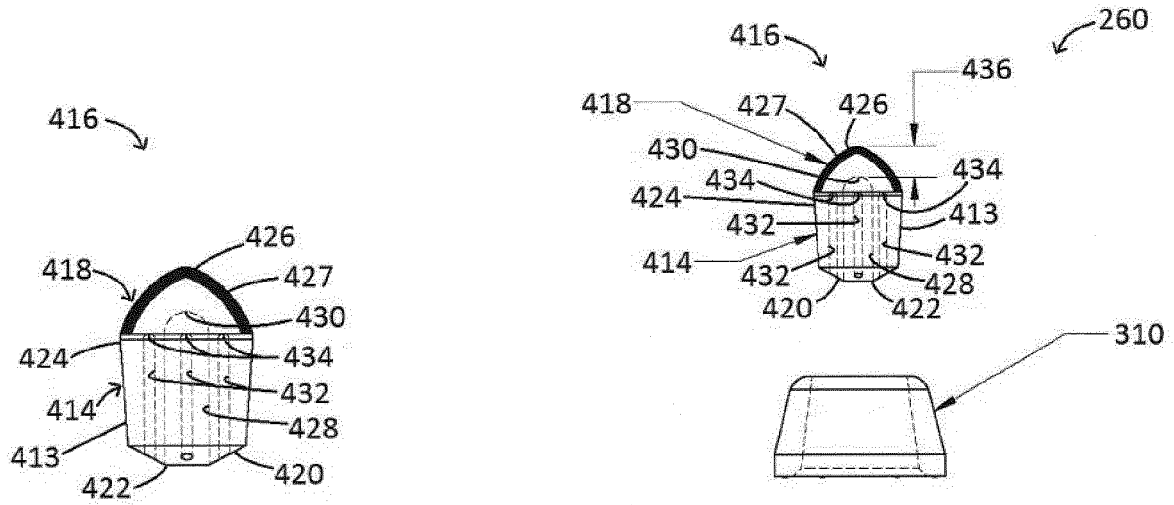

FIG. 14

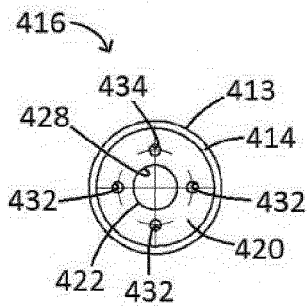

FIG. 15

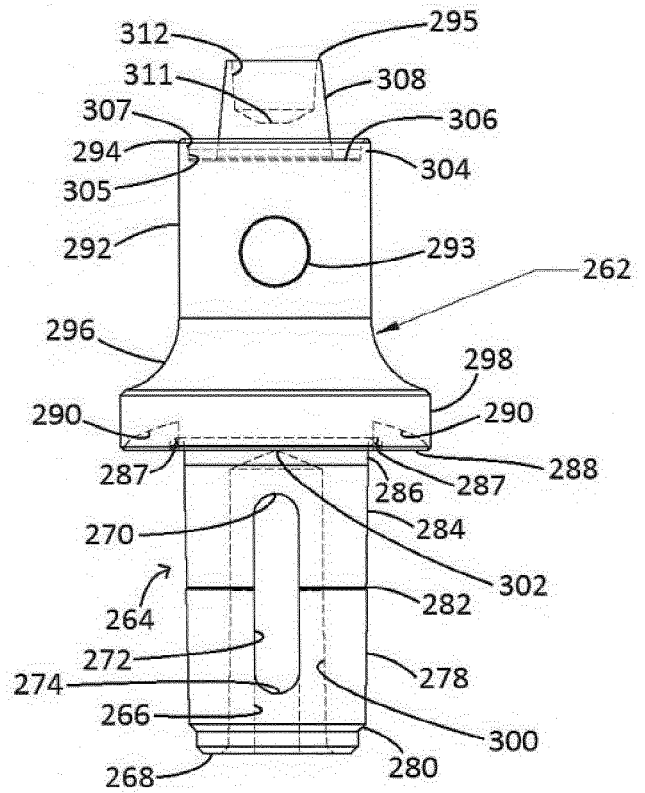

FIG. 16



EUROPEAN SEARCH REPORT

Application Number
EP 19 16 3685

5

10

15

20

25

30

35

40

45

50

55

DOCUMENTS CONSIDERED TO BE RELEVANT			
Category	Citation of document with indication, where appropriate, of relevant passages	Relevant to claim	CLASSIFICATION OF THE APPLICATION (IPC)
X	GB 2 534 370 A (HALCO ROCK TOOLS LTD [GB]) 27 July 2016 (2016-07-27) * page 10, line 15 - page 11, line 22 * -----	1-3,5-14	INV. E21B10/573 E21C35/183
A	US 5 924 501 A (TIBBITTS GORDON A [US]) 20 July 1999 (1999-07-20) * abstract *	1	
A	US 2008/145686 A1 (MIRCHANDANI PRAKASH K [US] ET AL) 19 June 2008 (2008-06-19) * paragraph [0037]; figure 51 * -----	1	
			TECHNICAL FIELDS SEARCHED (IPC)
			E21B E21C B28D E02F
The present search report has been drawn up for all claims			
Place of search		Date of completion of the search	Examiner
The Hague		2 September 2019	Rampelmann, Klaus
CATEGORY OF CITED DOCUMENTS			
X : particularly relevant if taken alone Y : particularly relevant if combined with another document of the same category A : technological background O : non-written disclosure P : intermediate document		T : theory or principle underlying the invention E : earlier patent document, but published on, or after the filing date D : document cited in the application L : document cited for other reasons & : member of the same patent family, corresponding document	

1
EPO FORM 1503 03/02 (P04C01)

ANNEX TO THE EUROPEAN SEARCH REPORT
ON EUROPEAN PATENT APPLICATION NO.

EP 19 16 3685

5 This annex lists the patent family members relating to the patent documents cited in the above-mentioned European search report.
The members are as contained in the European Patent Office EDP file on
The European Patent Office is in no way liable for these particulars which are merely given for the purpose of information.

02-09-2019

Patent document cited in search report	Publication date	Patent family member(s)	Publication date
GB 2534370	A	27-07-2016	NONE

US 5924501	A	20-07-1999	AU 1974697 A 02-09-1997
			DE 69714359 D1 05-09-2002
			EP 0828917 A2 18-03-1998
			US 5924501 A 20-07-1999
			US 6082223 A 04-07-2000
			WO 9730264 A2 21-08-1997

US 2008145686	A1	19-06-2008	BR PI0717332 A2 29-10-2013
			CA 2663519 A1 02-05-2008
			CN 101522930 A 02-09-2009
			CN 102764893 A 07-11-2012
			EP 2078101 A2 15-07-2009
			JP 5330255 B2 30-10-2013
			JP 5870071 B2 24-02-2016
			JP 2010507742 A 11-03-2010
			JP 2014037767 A 27-02-2014
			KR 20090069283 A 30-06-2009
			US 2008145686 A1 19-06-2008
			US 2011265623 A1 03-11-2011
			US 2013028672 A1 31-01-2013
			WO 2008051588 A2 02-05-2008
			ZA 200902032 B 25-09-2014

REFERENCES CITED IN THE DESCRIPTION

This list of references cited by the applicant is for the reader's convenience only. It does not form part of the European patent document. Even though great care has been taken in compiling the references, errors or omissions cannot be excluded and the EPO disclaims all liability in this regard.

Patent documents cited in the description

- US 6371567 B [0012]
- US 6585326 B [0012]
- US 6739327 B [0012] [0015]
- US 61944676 A [0013]
- US 62848215 A [0013]
- US 20150240634 A [0013]