



US 20110024989A1

(19) **United States**
(12) **Patent Application Publication**
Berdichevsky

(10) **Pub. No.: US 2011/0024989 A1**
(43) **Pub. Date: Feb. 3, 2011**

(54) **DYNAMIC SEAL**

continuation-in-part of application No. 11/065,023,
filed on Feb. 24, 2005, now Pat. No. 7,854,432.

(75) Inventor: **Alexander Berdichevsky,**
Farmington Hills, MI (US)

Publication Classification

Correspondence Address:
**FREUDENBERG-NOK GENERAL PARTNER-
SHIP**
LEGAL DEPARTMENT
47690 EAST ANCHOR COURT
PLYMOUTH, MI 48170-2455 (US)

(51) **Int. Cl.**
F16J 15/32 (2006.01)
F16J 15/16 (2006.01)
(52) **U.S. Cl.** *277/559; 277/500*

(73) Assignee: **FREUDENBERG-NOK**
GENERAL PARTNERSHIP,
Plymouth, MI (US)

(57) **ABSTRACT**

(21) Appl. No.: **12/902,716**

A dynamic shaft seal assembly is provided including a dynamic seal for engaging a rotary shaft. The dynamic seal includes a base portion that is mounted within a casing and has an axially extending barrel portion extending from a radially inner end of the base portion. The axially extending barrel portion terminates in a radially extending leg portion which extends inwardly from an end of the axially extending portion. A generally conically shaped seal portion extends from an end of the radially extending portion and the seal portion includes a radially inner face engaging the shaft and a radially outer face having a stiffening bead integrally formed thereon. The stiffening bead reduces the seal's propensity for "bell mouching" while the axially extending barrel portion provides improved shaft followability for the dynamic seal.

(22) Filed: **Oct. 12, 2010**

Related U.S. Application Data

(63) Continuation of application No. 11/285,652, filed on
Nov. 22, 2005, now Pat. No. 7,854,433, which is a

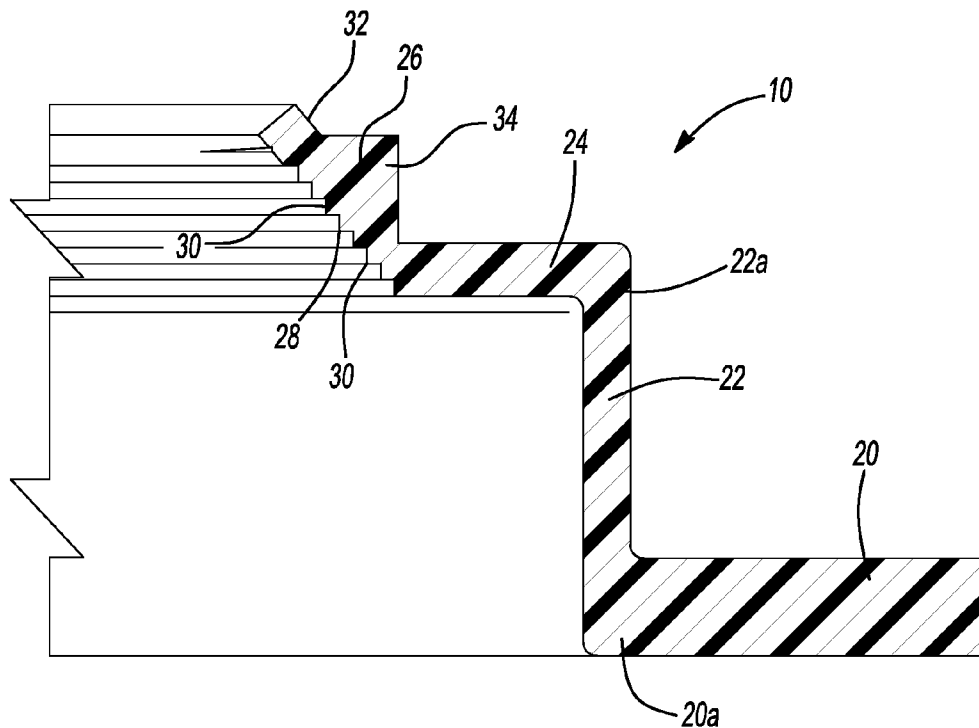

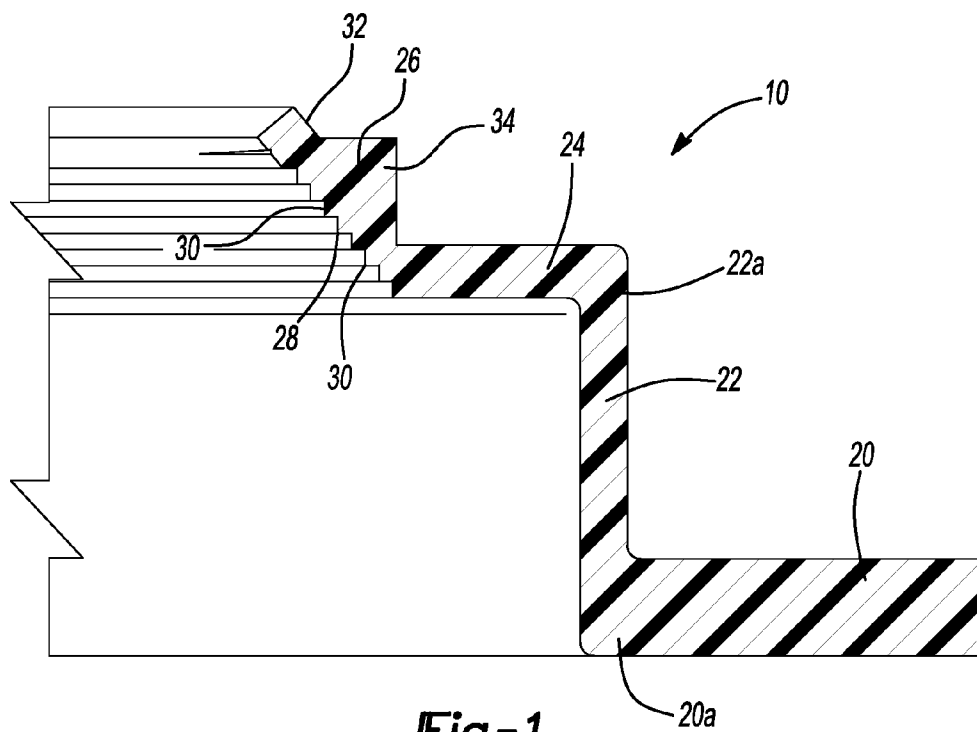

Fig-1

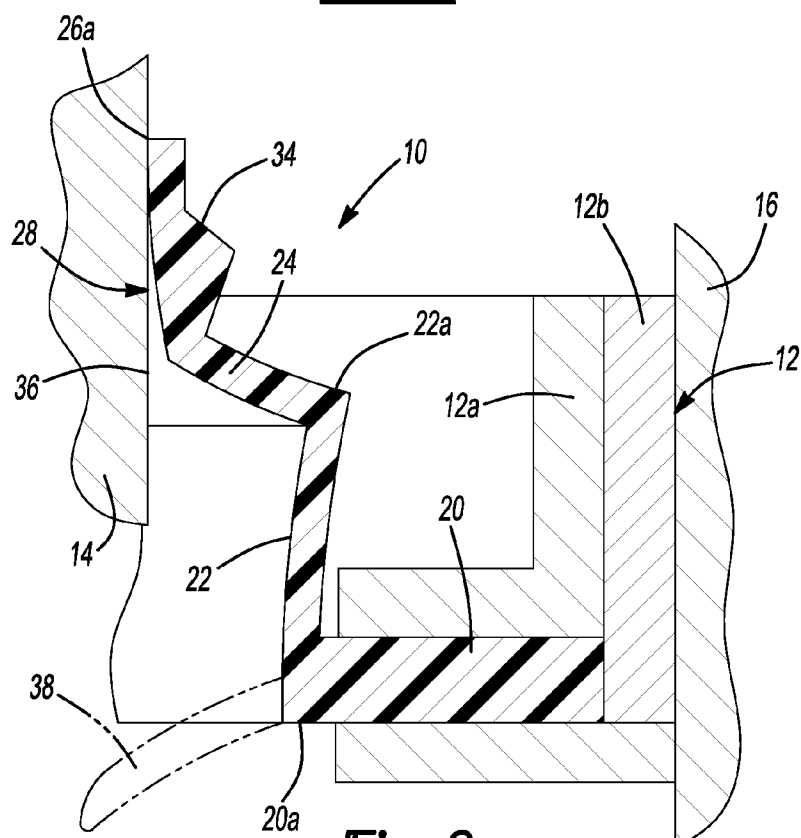

Fig-2

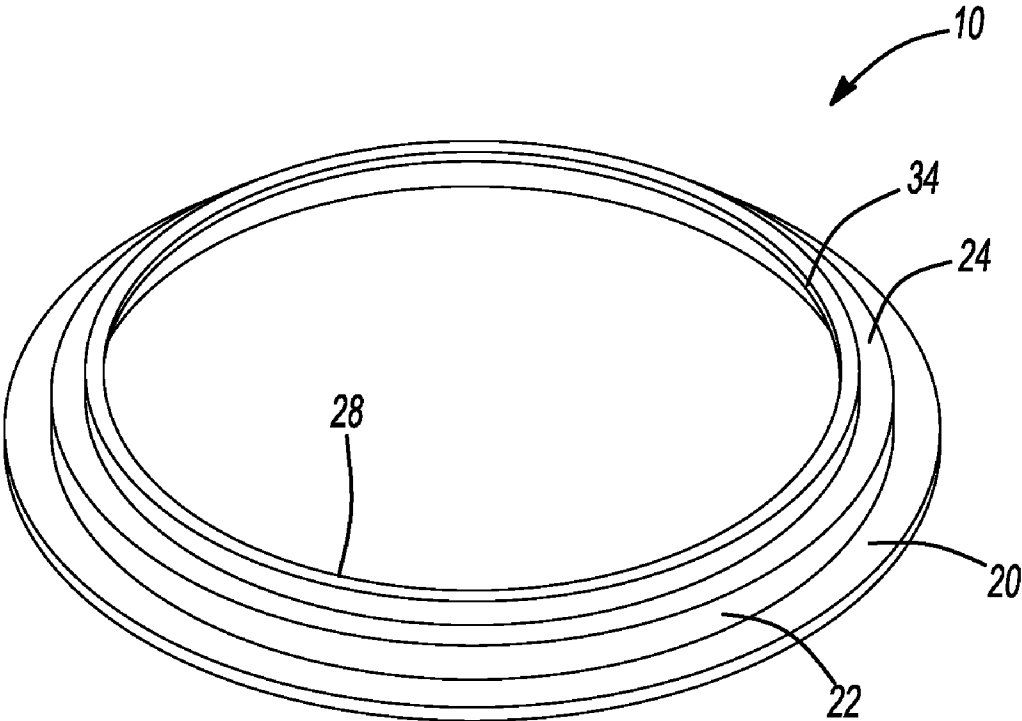

Fig-3

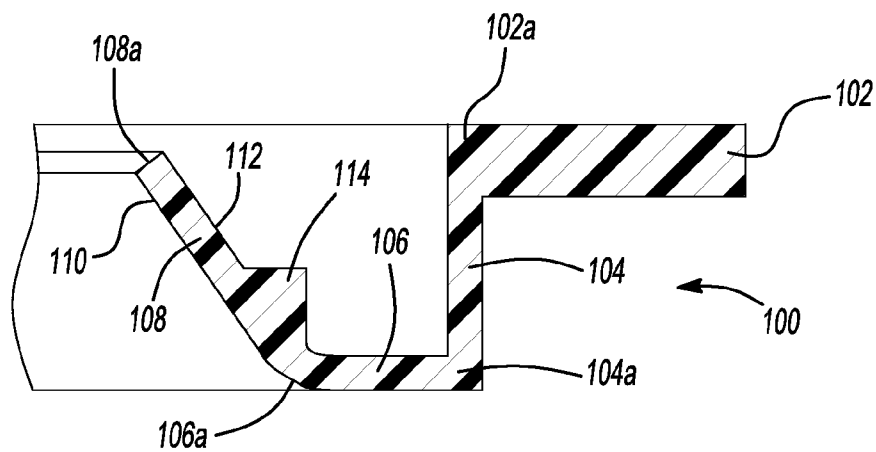

Fig-4

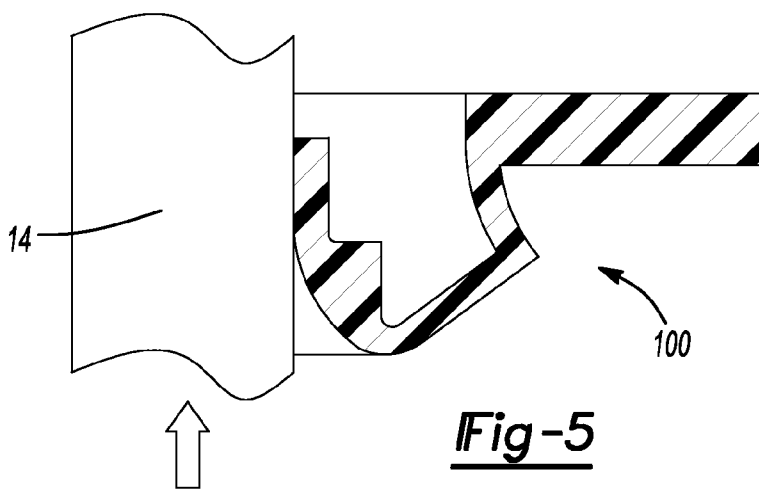

Fig-5

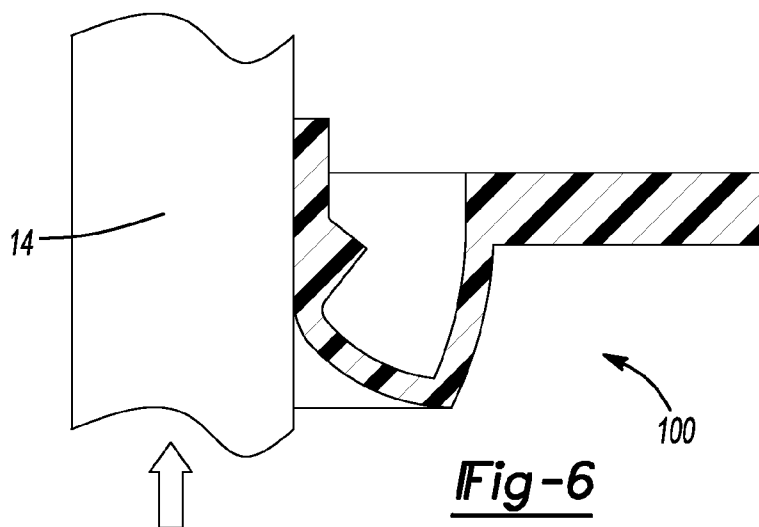

Fig-6

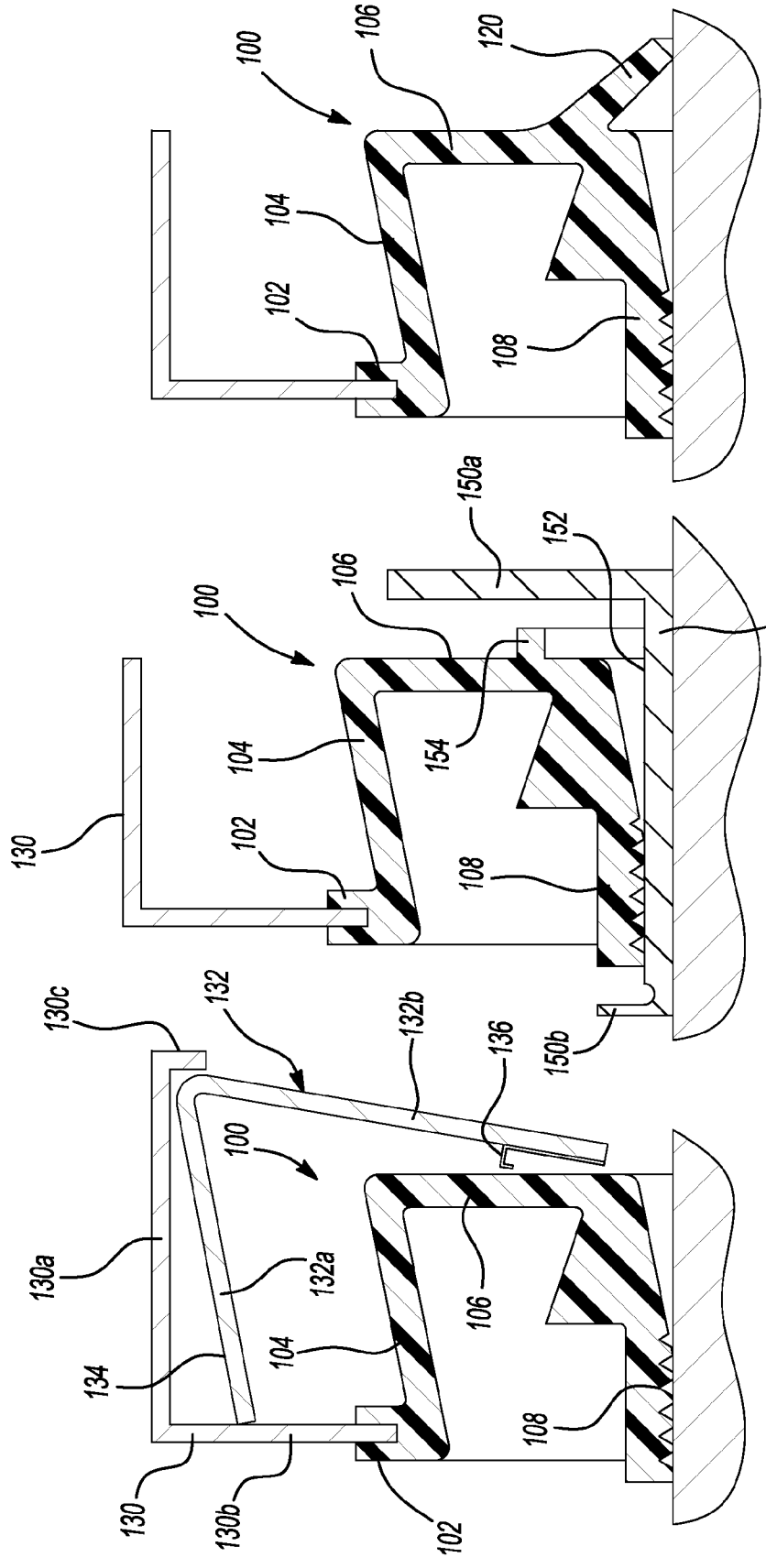

Fig-9

Fig-8

Fig-7

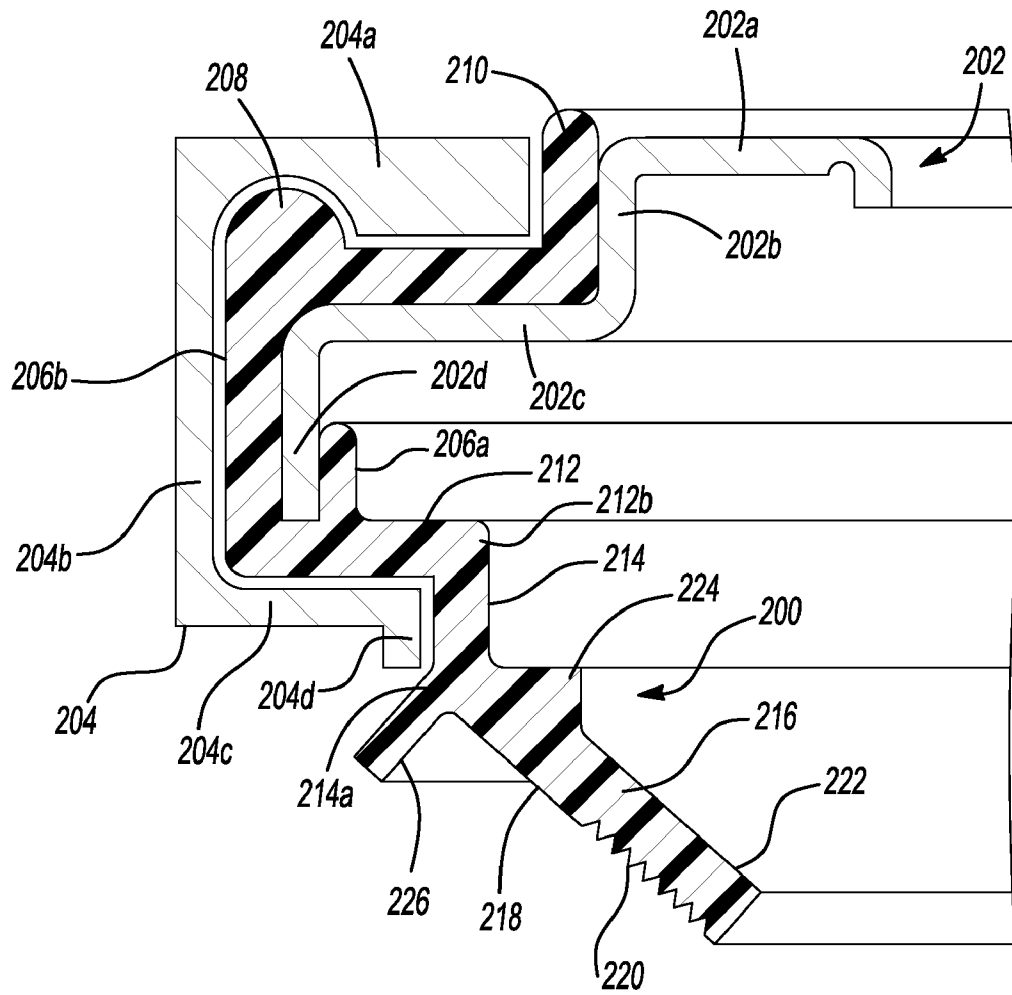

Fig-10

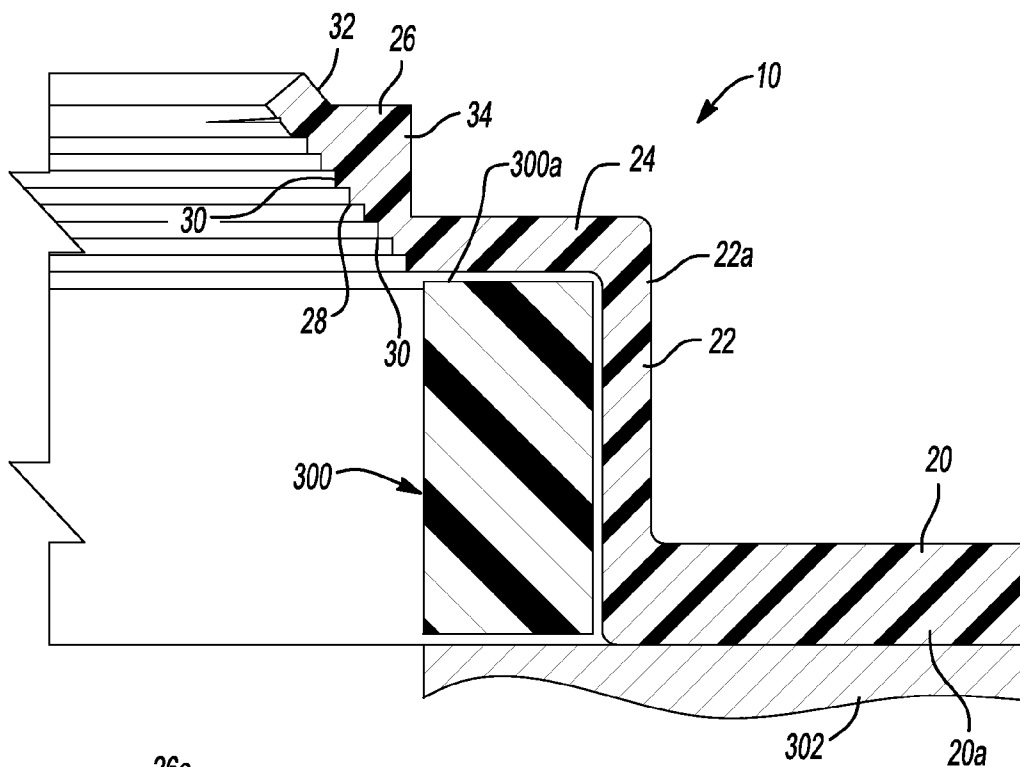

Fig-11

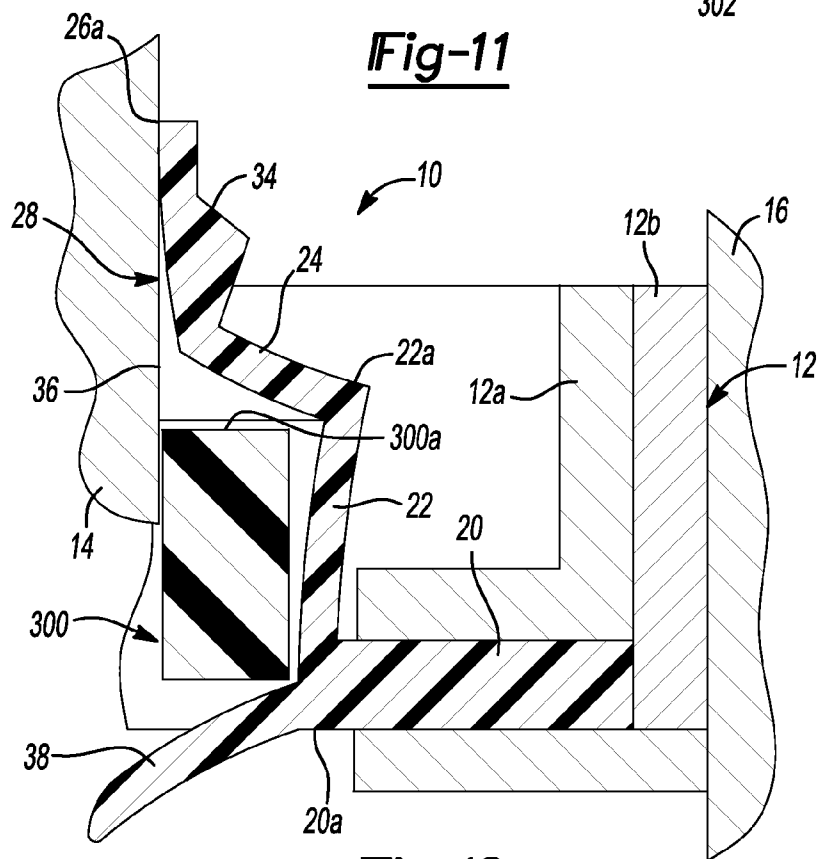

Fig-12

DYNAMIC SEAL

CROSS-REFERENCE TO RELATED APPLICATIONS

[0001] This application is a continuation of U.S. patent application Ser. No. 11/285,652, filed Nov. 22, 2005, which is a continuation-in-part of U.S. patent application Ser. No. 11/065,023, filed on Feb. 24, 2005, the disclosures of which are incorporated herein by reference in their entirety.

FIELD OF THE INVENTION

[0002] The present invention relates to “lay-down” dynamic shaft seals, and more particularly, to a dynamic shaft seal design to reduce the seal’s torque, propensity for bell mouthing, and for providing improved shaft followability and improved ability to withstand internal excessive pressure or vacuum. The “lay-down” seal for their function rely on hydrodynamic pumping features as opposed to “standard” or “point-contact” seals that rely primarily on the intrinsic ability of some elastomers to pump in properly designed seals.

BACKGROUND AND SUMMARY OF THE INVENTION

[0003] Rotary shaft seals have been utilized in machinery, the automobile industry, as well as other industries. Three major problems associated with seals designed to have substantial contact areas between the shaft and the lip of the seal are “bell mouth,” the shaft followability at low temperatures, and oil carbonization in the pumping grooves due to local temperature rise causing increased torque. “Bell mouth” is a phenomenon associated with the lift of the edge of the lip from the shaft. The problem is extenuated for highly incompressible materials, like rubber and PTFE. The ability of the seal to follow the shaft when the shaft either wobbles or is misaligned is also important to a seal design.

[0004] The present invention is designed to reduce seal torque, the propensity for “bell mouthing” and also provides for improved shaft followability at low temperatures. The dynamic seal includes an annular mounting portion which is capable of being mounted to a casing which surrounds a rotary shaft. The seal includes an axially extending portion extending from the radially inner end of the mounting portion, with a radially extending portion extending inwardly from an end of the axially extending portion. A generally conically shaped seal portion extends from an end of the radially extending portion with the seal portion including a radially inner face provided with a plurality of grooves or ribs and a radially outer face having a special bead defining a region of increased thickness. The bead acts as an integral spring to control the gap between the essentially conical portion of the seal and the shaft as well as a means for counteracting the “bell mouthing” propensity of the seal portion. The bead can have different shapes including a triangular-cross section or a rounded bead, as well as other configurations which are deemed to be appropriate. The bead is positioned slightly away from the edge of the lip to provide a sufficient lip “lay-down” to properly engage the hydrodynamic pumping features, which would normally be located on the lip contact area between the edge of the seal and the bead. The flexibility of the axially extending portion of the seal provides an improvement in the shaft followability due to the generally cylindrical shape of the axially extending portion having lower bending stiffness. Therefore, if the material of

the seal does not have sufficient intrinsic elasticity, making the axially extending portion of the seal in a generally cylindrical shape improves the overall shaft followability. The length and the wall thickness of the cylindrical portion allow one to control the degree of flexibility to match the application requirements.

[0005] Further areas of applicability of the present invention will become apparent from the detailed description provided hereinafter. It should be understood that the detailed description and specific examples, while indicating the preferred embodiment of the invention, are intended for purposes of illustration only and are not intended to limit the scope of the invention.

BRIEF DESCRIPTION OF THE DRAWINGS

[0006] The present invention will become more fully understood from the detailed description and the accompanying drawings, wherein:

[0007] FIG. 1 is a detailed cross-sectional view of the dynamic seal according to the principles of the present invention;

[0008] FIG. 2 is a cross-sectional view of the dynamic seal disposed against a shaft according to the principles of the present invention;

[0009] FIG. 3 is a perspective view of the dynamic seal according to the principles of the present invention;

[0010] FIG. 4 is a cross-sectional view of second embodiment of the dynamic seal according to the principles of the present invention;

[0011] FIG. 5 is a cross-sectional view of the seal of FIG. 4 shown under internal pressure;

[0012] FIG. 6 is a cross-sectional view of the seal of FIG. 4 shown under vacuum;

[0013] FIG. 7 is a cross-sectional view of a dynamic seal according to the principles of the present invention, incorporating a deflection limiting retainer;

[0014] FIG. 8 is a cross-sectional view of a dynamic seal according to the principles of the present invention including an interior shaft ring;

[0015] FIG. 9 is a cross-sectional view of a dynamic seal according to the principles of the present invention including a dust lip integrally formed therewith;

[0016] FIG. 10 is a cross-sectional view of a dynamic seal according to the principles of the present invention, including a support ring and casing;

[0017] FIG. 11 is a detailed cross-sectional view of the dynamic seal according to the principles of the present invention with a support ring disposed therein; and

[0018] FIG. 12 is a cross-sectional view of the dynamic seal disposed against a shaft according to the principles of the present invention with a support ring disposed therein.

DETAILED DESCRIPTION OF THE PREFERRED EMBODIMENTS

[0019] The following description of the preferred embodiment(s) is merely exemplary in nature and is in no way intended to limit the invention, its application, or uses.

[0020] With reference to FIGS. 1-3, the dynamic seal 10, according to the principles of the present invention, will now be described. The dynamic seal 10 is mounted to a casing 12 which is disposed in a fixed housing 16 (best shown in FIG. 2) in a manner which is well known in the art. The dynamic seal 10 engages a rotary shaft 14 so that the dynamic seal 10

provides a sealed relationship between the rotary shaft **14** and the housing **16** in which the casing **12** is disposed. With reference to FIG. 1, the dynamic seal **10** includes a mounting portion **20** which is designed to be engaged between first and second portions **12A**, **12B** of casing **12**. It should be noted that the mounting portion **20** can take on many shapes and forms and is not considered to be particularly relevant to the present invention. The mounting portion **20** is mounted to the casing **12** which can be made of plastic or metal and the mounting portion **20** can be clamped or bonded thereto according to well known mounting techniques.

[0021] The dynamic seal **10** includes an axially extending barrel portion **22** extending from a radially inner end **20A** of the mounting portion **20**. The axially extending barrel portion **22** is preferably generally cylindrical in shape although other shapes, such as conical or a convoluted curve shape, can also be utilized. The dynamic seal **10** includes a radially extending portion **24** extending inwardly from a distal end **22B** of the axially extending barrel portion **22**. A generally conically shaped seal portion **26** extends from a radially innermost end **24A** of the radially extending portion **24**. The seal portion **26** includes a radially inner face **28** which may be provided with a plurality of grooves **30**. The grooves **30** can be helical in shape or can take other known forms. The grooves **30** provided in the radially inner surface **28** of the seal portion **26** are capable of retaining oil therein in order to provide lubrication between the dynamic shaft seal **10** and rotary shaft **14** and also can provide a pumping function for returning leaked oil to the oil side of the seal. A radially outer face **32** of the conically shaped seal portion **26** is provided with a stiffening bead **34** defining a region of increased thickness. The stiffening bead **34** can have different shapes, including a triangular shape, as shown, or can have rounded or other shape configurations. The stiffening bead **34** is positioned slightly away from the end edge **26A** of the lip **26** to allow a proper contact area to develop. The bead **34** serves as an integrally formed spring for biasing the sealing lip **26** against the rotary shaft **14** for counteracting bell mouthing of the sealing lip **26**. Normally, the seal lip-free edge faces the oil side. However, reverse mounting is also possible. In that case, the design of the spiral grooves have to be accommodated appropriately to pump in the direction of the oil sump.

[0022] The improvement in the shaft followability of the dynamic seal **10** is provided by the axially extending barrel portion **22**. The generally cylindrical shape of the barrel portion **22** has a lower bending stiffness than other structures; therefore, the axially extending barrel portion **22** is able to readily account for a wobbling shaft or a shaft that is out of center relative to the housing **16**.

[0023] It should be noted that if desired or advantageous in a particular application, the dynamic shaft seal **10** of the present invention can optionally include one or more axial or radial dirt protective lips **38** as are known in the art, one of which is shown, for example, in FIG. 2. The optional dirt protective lip **38** can be formed integrally with the dynamic shaft seal, or can be formed separately therefrom and attached thereto, and can have any of a number of shapes or configurations, as is also known in the art. In addition, the lip **38** can protrude transversely from the dynamic shaft seal in any of a number of directions, including, but not limited to, the exemplary angular relationship protruding generally radially away and axially away from the shaft-engaging sealing components, as shown, for example, in FIG. 2.

[0024] The radially extending leg portion **24** can be straight, as shown, or alternatively, can be provided with a convoluted shape. The outer diameter of the shaft is specifically designed to have a larger diameter than the inner diameter of the radially inwardly extending leg portion **24**. As illustrated in FIG. 2, the generally conically shaped seal portion **26** is designed to take on a generally cylindrical form when deformed by the rotary shaft **14** and the leg **24** is designed to apply pressure to the heel portion **36** of the seal portion **26**. The leg portion **24** acts radially on the end **22A** of the barrel portion **22** which has a length sufficient to allow the barrel portion **22** to flex radially inwardly and outwardly to accommodate for shaft wobble or shaft misalignment. The length of the leg portion is derivative from the length of the seal portion, the amount of the seal-to-shaft interference, and the distance between the casing and the shaft.

[0025] The dynamic shaft seal **10** of the present invention can be utilized for isolating an oil environment from an air environment disposed on either side of the dynamic seal **10**. In order to optimize the seal design, the length of the seal portion **26** and the stiffness of the bead **34** (geometry, thickness, material, etc.) are specifically chosen for particular applications. Furthermore, the thickness of the radially extending leg portion **24** is also specifically designed to provide sufficient pressure on the heel **36** of the seal portion **26**. The thickness and length of the barrel portion **22** should also be specifically designed to accommodate the requisite flexibility of a particular application. The seal material composition for the dynamic seal can include plastic, rubber, or any of a wide variety of known elastomers, such as PTFE, TPE (thermoplastic elastomers), TPV (thermoplastic vulcanizates), and Flouroprene™ material, a composition described in U.S. Pat. No. 6,806,306. An additional embedded spring in the bead may be utilized in order to extend the life of the seal due to the fact that creep can occur in thermoplastic or elastomeric materials which prevents the material from regaining its original properties. The spring would then provide an additional radial load on the seal surface that the thermoplastic material is incapable of maintaining over a long life. The spring can also improve the robustness of the seal required in contaminated environments. Instead of imbedding, the spring can be placed in a specially designed and manufactured spring groove after completion of the molding operation (as is normal with other radial lip seals).

[0026] With reference to FIGS. 4-6, a dynamic seal according to a second embodiment of the present invention will now be described. The dynamic seal **100** includes a mounting portion **102** which is designed to be engaged between first and second portions of a casing. It should be noted that the mounting portion **102** can take on many shapes and forms and is not considered to be particularly relevant to the present invention. The mounting portion **102** is mounted to a casing which can be made of plastic or metal and the mounting portion **102** can be clamped, bonded or otherwise secured thereto according to well-known mounting techniques.

[0027] The dynamic seal **100** includes an axially extending barrel portion **104** extending from a radially inner end **102A** of the mounting portion **102**. The axially extending barrel portion **104** is preferably generally cylinder shaped although other shapes, such as conical or a convoluted curve shape, can also be utilized. The dynamic seal **100** includes a radially extending portion **106** extending inwardly from a distal end **104A** of the axially extending barrel portion **104**. A generally

conically shaped seal portion **108** extends from a radially innermost end **106A** of the radially extending portion **106**.

[0028] The axially extending barrel portion **104** extends in a first axial direction from mounting portion **102**, while the generally conically shaped seal portion **108** extends from the radially innermost end **106A** of radially extending portion **106** in an axial direction opposite to the first axial direction.

[0029] The seal portion **108** includes a radially inner face **110** which may be provided with at least one groove or a plurality of grooves. The grooves can be helical in shape or can take other known forms. The grooves provided in the radially inner surface **110** of the seal portion **108** are capable of retaining oil therein in order to provide lubrication between the dynamic shaft seal **100** and rotary shaft **14** and also can provide a pumping function for returning leaked oil to the oil side of the seal.

[0030] A radially outer face **112** of the conically shaped seal portion **108** is provided with a stiffening bead **114** defining a region of increased thickness. The stiffening bead **114** can have different shapes, including a triangular shape as shown, or can have rounded or other shaped configurations. The stiffening bead **114** is positioned slightly away from the end edge **108A** of the lip **108** to allow a proper contact area to develop. The bead **114** serves as an integrally formed spring for biasing the sealing lip **108** against the rotary shaft **14** for counteracting bell mounting of the sealing lip **108**. The location and shape of the bead **114** is dependent upon the specific application and the desired spring force.

[0031] Normally, the seal lip-free edge **108A** faces the oil side. However, reverse mounting is also possible. In that case, the design of the spiral grooves has to be accommodated appropriately to pump in the direction of the oil side.

[0032] With the design of the present invention, the dynamic seal **100** is capable of withstanding excessive internal pressure or vacuum. FIG. **5** illustrates a cross-sectional view of the dynamic seal **100** disposed against a shaft **14** and under a pressure of 170 MBAR. FIG. **6** illustrates the dynamic seal **100** disposed against a shaft **14** and exposed to a vacuum pressure of -50 MBAR. In the case of excessive internal pressure being applied to the dynamic seal **100**, the axially extending barrel portion **22** which radially overlaps the seal portion **108** provides a radial spring acting upon the radially extending portion **106** to limit the deformation in the seal portion **108**.

[0033] In the case of an excessive vacuum being applied, the axially extending barrel portion **104** limits the axial movement of radially extending portion **106**, thus limiting the axial movement of the seal portion **108**.

[0034] The improvement in the shaft followability of the dynamic seal **100** is provided by the axially extending barrel portion **104**. The generally cylindrical shape of the barrel portion **104** has a lower bending stiffness than other structures. Therefore, the axially extending barrel portion **104** is able to readily account for a wobbling shaft or a shaft that is out of center relative to the housing.

[0035] It should be noted that if desired or advantageous in a particular application, the dynamic seal shaft **100** of the present invention can optionally include one or more axial or radial dirt protective lips **120** as illustrated in FIG. **9**. The optional dirt protective lip **120** can be formed integrally with the dynamic shaft seal, or it can be formed separately therefrom and attached thereto and can have any of a number of shapes or configurations, as is also known in the art. The radially extending leg portion **106** can be straight, as shown,

or alternatively, can be provided with an angled or convoluted shape. As illustrated in FIGS. **5** and **6**, the generally conically shaped seal portion **108** is designed to take on a generally cylindrical form when deformed by the rotary shaft **14** and the leg **106** is designed to apply pressure to the heel portion of the seal portion **108**. The leg portion **106** acts radially on the end **104A** of the barrel portion **104** which has a length sufficient to allow the barrel portion **104** to flex radially inwardly and outwardly to accommodate for shaft wobble or shaft misalignment. The length of the leg portion **106** is derivative from the length of the seal portion **108**, the amount of the seal-to-shaft interference, and the distance between the casing and the shaft.

[0036] The dynamic shaft seal **100** can be utilized for isolating an oil environment from an air environment disposed on either side of the dynamic seal **100**. In order to optimize the seal design, the length of the seal portion **108** and the stiffness of the bead **114** (geometry, thickness, material, etc.) are specifically chosen for particular applications. Furthermore, the thickness of the radially extending leg portion **106** is also specifically designed to provide sufficient pressure on the heel of the seal portion **108**. The thickness and length of the barrel portion **104** should also be specifically designed to accommodate the requisite flexibility of a particular application. The seal material composition for the dynamic seal can include plastic, rubber, or any of a variety of known elastomers, such as PTFE, TPE (thermoplastic elastomers), TPV (thermoplastic vulcanizates) and Fluoroprene™ material.

[0037] With reference to FIG. **7**, the dynamic seal **100** according to the principles of the present invention is shown mounted to a retainer ring **130**. The retainer ring **130** is designed to be press fit within a bore of a housing and includes an axially extending portion **130A**, a first radially extending mounting portion **130B** to which the dynamic seal **100** is mounted, and a retaining flange **130C** disposed at an opposite end of the axially extending portion **130A**. A support ring **132** includes an axially extending arm portion **132A** and a radially inwardly extending arm portion **132B**. The axially extending arm portion **132A** is designed to be retained by the retainer **130** and can include an inwardly angled exterior surface **134** which facilitates the support ring **132** to being press fit within retaining flange **130C**. The radially inwardly extending arm portion **132B** is disposed adjacent to the radially extending portion **106** of dynamic seal **100** with an axial gap extending therebetween. The gap **136** permits axial movement of the radially extending portion **106**, but limits the axial movement thereof relative to the mounting portion **102**.

[0038] With reference to FIG. **8**, a dynamic seal **100**, according to the principles of the present invention is shown utilized in a cassette-type seal including a running sleeve **150** adapted to be mounted to a shaft and to be rotated therewith. The running sleeve **150** includes a finished exterior surface **152** that is engaged by the seal portion **108** of dynamic seal **100**. The running sleeve **150** also includes a radial wall portion **150A** extending adjacent to the radially extending portion **106** of the dynamic seal **100**. The radial wall portion **150A** limits the axial movement of the radially extending portion **106** of dynamic seal **100** in the rightward direction as illustrated in FIG. **8**. The radially extending portion **106** of the dynamic seal **100** may also include a protruding portion **154** that can come in contact with the radially extending wall portion **150A** of running sleeve **150**. The protruding portion **154** limits the contact surface that engages the radial wall

portion 150A so as to limit the friction contact between the dynamic seal 100 and running sleeve 150.

[0039] The running sleeve 150 also includes a radial flange portion 150B provided at a second end thereof that provides a barrier for limiting axial movement of the seal portion 108 in the leftward direction as illustrated in FIG. 8. Thus, the retaining flange 150B prevents the seal portion 108 from being dislodged from the exterior finished surface 152 of running sleeve 150. The running sleeve 150 can be connected to the retainer 130 so that the seal assembly can be assembled as a cassette-type seal or can be separate, as shown.

[0040] With reference to FIG. 10, a dynamic seal 200, according to the principles of the present invention, is shown. The dynamic seal 200 is mounted to a metal casing 202 and is also provided with a support ring 204 which can be made from plastic, metal, or other materials. The dynamic seal 200 is mounted to the casing 202 which is adapted to be disposed in a fixed housing in a manner which is well known in the art. The dynamic seal 200 engages a rotary shaft or other member so that the dynamic seal 200 provides a sealed relationship between the rotary member and the housing in which the casing 202 is disposed. The dynamic seal 200 includes a mounting portion 206A, 206B with the portion 206B of the mounting portion overlapping the metal casing 202 on at least one face thereof. A mounting portion 206B defines a bead portion 208 extending radially outward away from casing 202. The mounting portion 206B can also extend radially beyond metal casing 202 so as to provide a friction engagement with the housing in which the seal assembly is inserted. The mounting portion 206A, 206B can take on many shapes and forms. The dynamic seal 200 includes an axially extending barrel portion 212 extending from a radially inner end of the mounting portion 206A, 206B, the axially extending barrel portion 212 is preferably general cylindrical in shape, although other shapes, such as conical or a convoluted curve shape, can also be utilized. The dynamic seal 200 includes a radially extending portion 214 extending inwardly from a distal end 212B of the axially extending barrel portion 212. A generally conically shaped seal portion 216 extends from a radially innermost end 214A of the radially extending portion 214. The seal portion 216 includes a radially inner face 218 which may be provided with a plurality of grooves 220. The grooves 220 can be helical in shape or can take other known forms. The grooves 220 provided in the radially inner surface 218 of the seal portion 216 are capable of retaining oil therein in order to provide lubrication between the dynamic shaft seal 200 and a rotary member, and also can provide a pumping function for returning leaked oil to the oil side of the seal. A radially outer face 222 of the conically shaped seal portion 216 is provided with a stiffening bead 224 defining a region of increased thickness. The stiffening bead 224 can have different shapes, including a triangular shape, as shown, or can have rounded or other shaped configurations. The stiffening bead of 224 is provided to allow a proper contact area to develop on the sealing lip 216. The bead 224 serves as an integrally formed spring for biasing the sealing lip 216 against the rotary shaft for counteracting bell mouthing of the sealing lip 216. Normally, the seal lip-free edge faces the oil side. However, reverse mounting is also possible. A dirt protective lip 226 extends from the end portion 214A of radially extending leg portion 214.

[0041] The support ring 204 includes an outer ring portion 204A which engages the bead 208 of mounting portion 206B in order to provide an axial restraint on the support ring 204. A

radially extending portion 204B extends radially inward from the outer ring portion 204A and a second inner ring portion 204C extends axially from an innermost end portion of radial portion 204B. The inner ring 204C extends axially and parallel to the axially extending barrel portion 212 of dynamic seal 200. The inner ring 204C limits the radial movement of the axially extending barrel portion 212. The inner ring portion 204C includes a radially inwardly extending leg portion 204D which is generally parallel to the radially extending portion 214 of the dynamic seal 200. The radially extending leg portion 204D limits the axial movement of the radially extending portion 214 of the dynamic seal.

[0042] The casing 202 includes an outer ring portion 202A adapted to be received in a bore of a housing. A first radially inward step portion 202B extends radially inward from the outer ring portion 202A. An intermediate ring portion 202C extends axially from the radially inwardly extending portion 202B. A mounting arm 202D extends radially inward from the intermediate axial portion 202C. The dynamic seal 200 is mounted to the radially inwardly extending arm 202D.

[0043] With reference to FIG. 11, a free floating support ring 300 is shown for use with the dynamic seal 10 which is shown in FIG. 1. The support ring 300 can be formed from plastic, metal, or other materials. The support ring 300 extends axially and parallel to the axially extending barrel portion 22 of the dynamic seal 10 and limits the radial movement of the axially extending barrel portion 22. The support ring 300 includes a radially extending end surface 300a which is generally parallel to the radially extending portion 24 of the dynamic seal 10. The radially extending end surface 300a limits the axial movement of the radially extending portion 24 of the dynamic seal. The support ring 300 is restrained from axial movement by radially extending portion 24 and by the exterior housing 302, or can be otherwise restrained by other members such as a dust lip 38, as shown in FIG. 12, or by other means either attached to or separate from the seal assembly.

[0044] The description of the invention is merely exemplary in nature and, thus, variations that do not depart from the gist of the invention are intended to be within the scope of the invention. Such variations are not to be regarded as a departure from the spirit and scope of the invention.

What is claimed is:

1. A dynamic seal, comprising:

- an annular mounting portion;
- an axially extending portion extending in a first axial direction from said mounting portion toward an air side of the dynamic seal and terminating in a first end;
- a radially extending portion extending radially inwardly from said first end of said axially extending portion and being displaceable in a radially outward direction; and
- a generally conically shaped seal portion extending from an end of said radially extending portion in a direction opposite said first axial direction toward an oil side of the dynamic seal, said seal portion being adapted to take on a generally cylindrical form when engaged with a rotary member and thereby including a radially inner face adapted to engage the rotary member along a substantial axial length thereof, wherein said radially inner face of said seal portion is provided with at least one groove for retaining oil therein for providing a lubricated interface between the seal portion and the rotary member and providing a pumping function for returning leaked oil to the oil side of the dynamic seal.

2. The dynamic seal according to claim 1, wherein said seal is made from an elastomeric material.

3. The dynamic seal according to claim 1, wherein said seal is made from a plastic material.

4. The dynamic seal according to claim 1, further comprising a dirt lip extending from said radially extending portion.

5. The dynamic seal according to claim 4, wherein said dirt lip is integrally formed with said radially extending portion.

6. The dynamic seal according to claim 1, wherein the composition of said dynamic seal includes one of PTFE, thermoplastic elastomer, and thermoplastic vulcanizates.

* * * * *