



US00D740145S

(12) **United States Design Patent**
Holst et al.

(10) **Patent No.:** **US D740,145 S**

(45) **Date of Patent:** **** Oct. 6, 2015**

(54) **SENSOR**

Primary Examiner — Antoine D Davis

(71) Applicant: **WESTERNGECO L.L.C.**, Houston, TX (US)

(57) **CLAIM**
The ornamental design for a sensor, as shown and described.

(72) Inventors: **Einar Holst**, Oslo (NO); **Seth Friedly**, Sandvika (NO); **Kambiz Iranpour**, Oslo (NO)

DESCRIPTION

(73) Assignee: **WESTERNGECO L.L.C.**, Houston, TX (US)

FIG. 1 is a perspective view of a sensor according to a first embodiment.

(**) Term: **14 Years**

FIG. 2 is a front elevational view of the sensor according to the first embodiment, the rear elevational view thereof being a mirror image.

(21) Appl. No.: **29/497,500**

FIG. 3 is a right elevational view of the sensor according to the first embodiment, the left elevational view thereof being a mirror image.

(22) Filed: **Jul. 25, 2014**

FIG. 4 is a top plan view of view of the sensor according to the first embodiment.

(51) **LOC (10) CI.** **10-04**

FIG. 5 is a bottom plan view of the sensor according to the first embodiment.

(52) **U.S. CI.**
USPC **D10/83**

FIG. 6 is a perspective view of a sensor according to a second embodiment.

(58) **Field of Classification Search**
USPC D10/83, 70
CPC G01V 1/00-1/202; G01V 1/208-1/523;
G01V 2001/204-2001/207; G01V 2001/526;
G01V 2210/00-2210/74
See application file for complete search history.

FIG. 7 is a front elevational view of the sensor according to the second embodiment, the rear elevational view thereof being a mirror image.

(56) **References Cited**

U.S. PATENT DOCUMENTS

| | | | | |
|--------------|------|---------|-------------------------|-----------|
| 4,163,206 | A * | 7/1979 | Hall, Jr. | 367/160 |
| 5,531,112 | A * | 7/1996 | Young et al. | 73/152.02 |
| 6,034,923 | A * | 3/2000 | Wooters | 367/21 |
| 6,262,945 | B1 * | 7/2001 | Maples et al. | 367/154 |
| D698,677 | S * | 2/2014 | Gateman | D10/83 |
| D700,088 | S * | 2/2014 | Brizard | D10/83 |
| 2007/0235250 | A1 * | 10/2007 | Krumhansl et al. | 181/121 |
| 2011/0216625 | A1 * | 9/2011 | Manin et al. | 367/15 |
| 2012/0134237 | A1 * | 5/2012 | Esteban-Campillo et al. | 367/136 |
| 2013/0308426 | A1 * | 11/2013 | Scarlatti et al. | 367/129 |

* cited by examiner

FIG. 8 is a right elevational view of the sensor according to the second embodiment, the left elevational view thereof being a mirror image.

FIG. 9 is a top plan view of the sensor according to the second embodiment.

FIG. 10 is a bottom plan view of the sensor according to the second embodiment.

FIG. 11 is a perspective view of a sensor according to a third embodiment.

FIG. 12 is a front elevational view of the sensor according to the third embodiment, the rear elevational view thereof being a mirror image.

FIG. 13 is a right elevational view of the sensor according to the third embodiment, the left elevational view thereof being a mirror image.

FIG. 14 is a top plan view of the sensor according to the third embodiment.

FIG. 15 is a bottom plan view of the sensor according to the third embodiment.

FIG. 16 is a perspective view of a sensor according to a variant of the first embodiment.

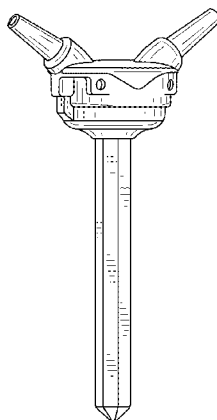

FIG. 17 is a front elevational view of the sensor according to the variant of the first embodiment, the rear elevational view thereof being a mirror image.

FIG. 18 is a right elevational view of the sensor according to the variant of the first embodiment, the left elevational view thereof being a mirror image.

FIG. 19 is a top plan view of view of the sensor according to the variant of the first embodiment.

FIG. 20 is a bottom plan view of the sensor according to the variant of the first embodiment.

FIG. 21 is a perspective view of a sensor according to a variant of the second embodiment.

FIG. 22 is a front elevational view of the sensor according to the variant of the second embodiment, the rear elevational view thereof being a mirror image.

FIG. 23 is a right elevational view of the sensor according to the variant of the second embodiment, the left elevational view thereof being a mirror image.

FIG. 24 is a top plan view of the sensor according to the variant of the second embodiment.

FIG. 25 is a bottom plan view of the sensor according to the variant of the second embodiment.

FIG. 26 is a perspective view of a sensor according to a variant of the third embodiment.

FIG. 27 is a front elevational view of the sensor according to the variant of the third embodiment, the rear elevational view thereof being a mirror image.

FIG. 28 is a right elevational view of the sensor according to the variant of the third embodiment, the left elevational view thereof being a mirror image.

FIG. 29 is a top plan view of the sensor according to the variant of the third embodiment; and,

FIG. 30 is a bottom plan view of the sensor according to the variant of the third embodiment.

1 Claim, 12 Drawing Sheets

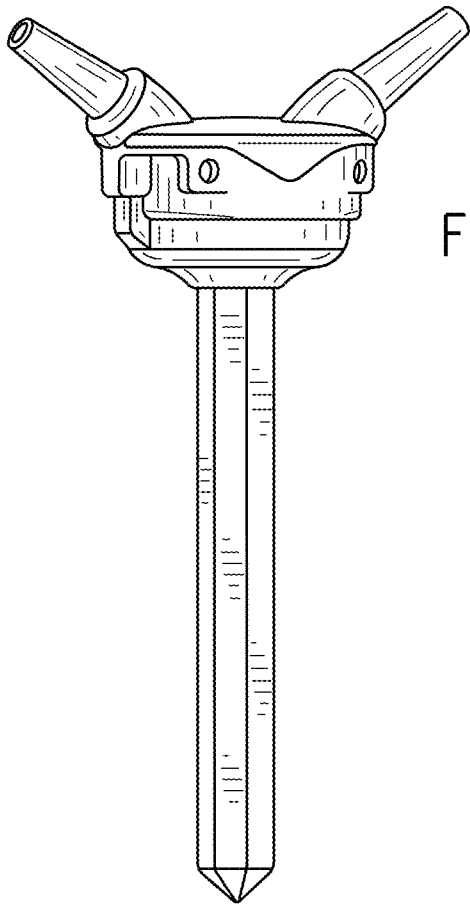

FIG. 1

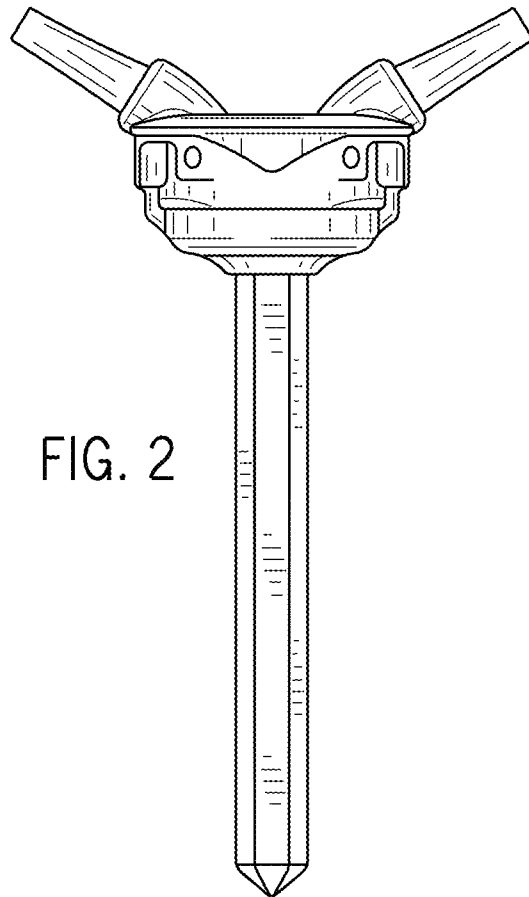

FIG. 2

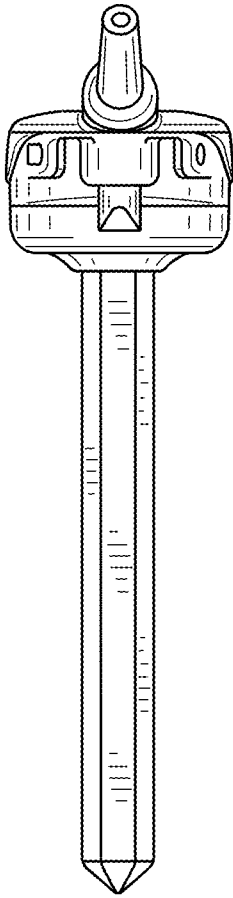

FIG. 3

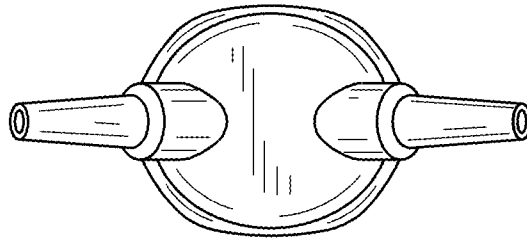

FIG. 4

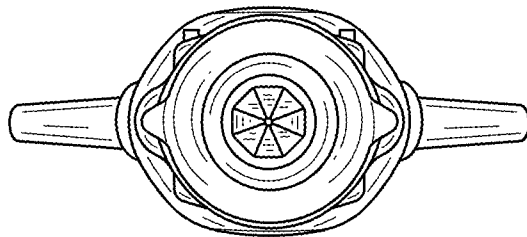

FIG. 5

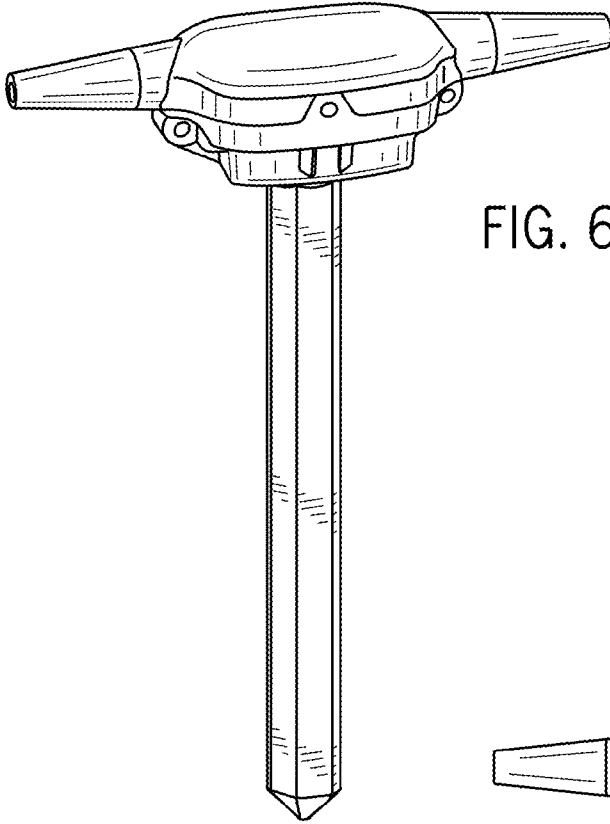

FIG. 6

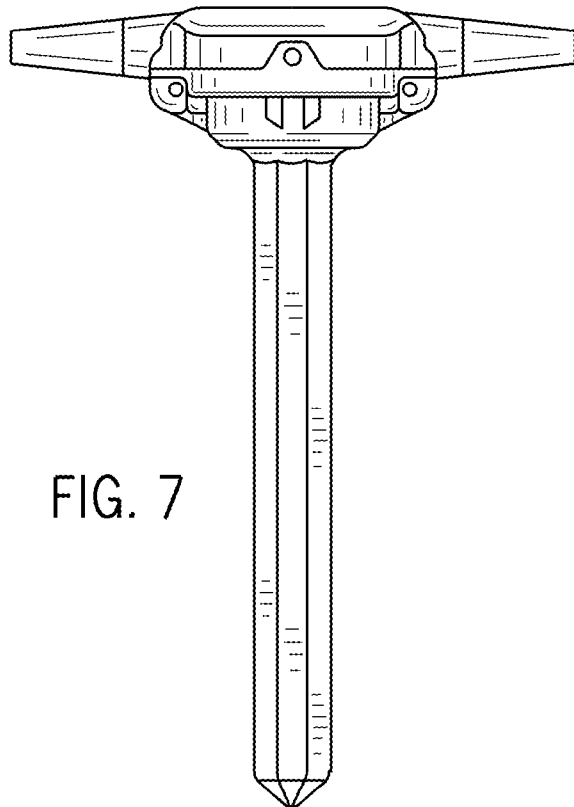

FIG. 7

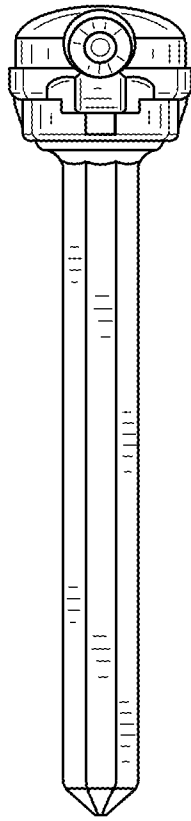

FIG. 8

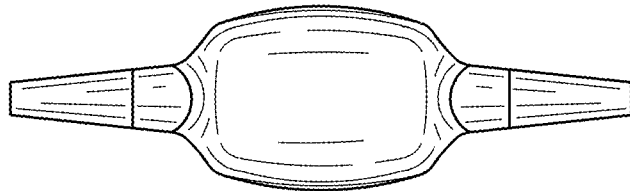

FIG. 9

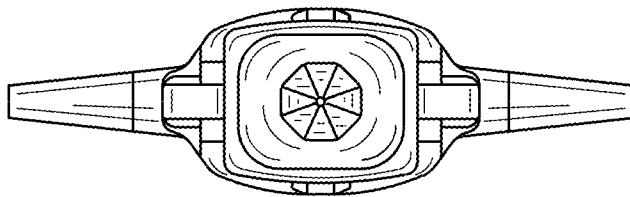

FIG. 10

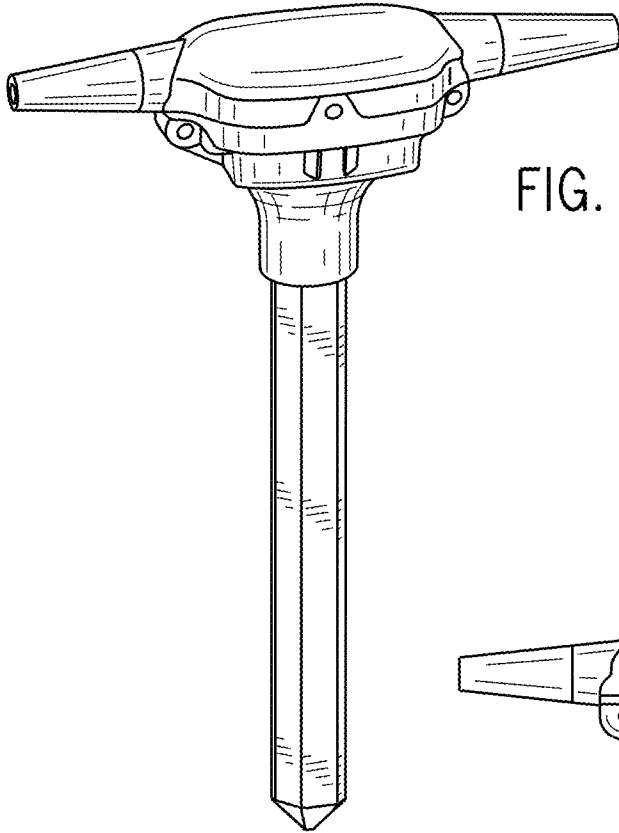

FIG. 11

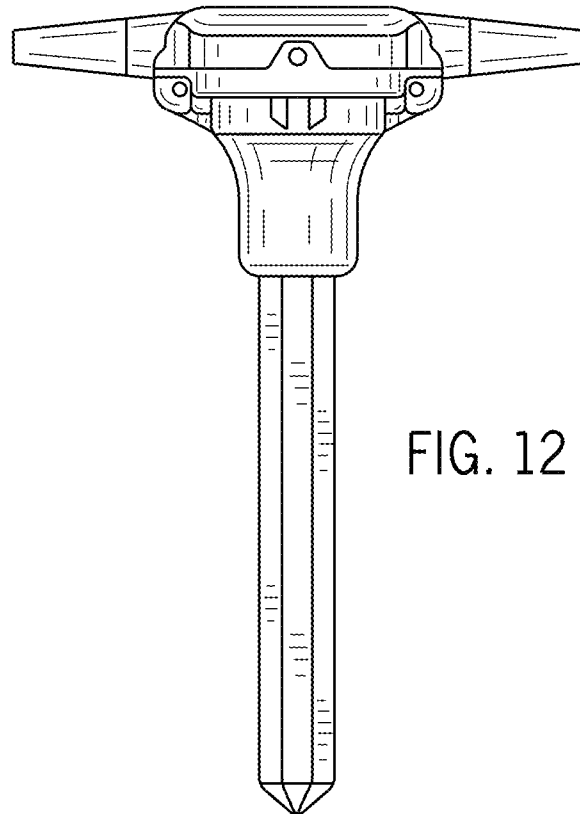

FIG. 12

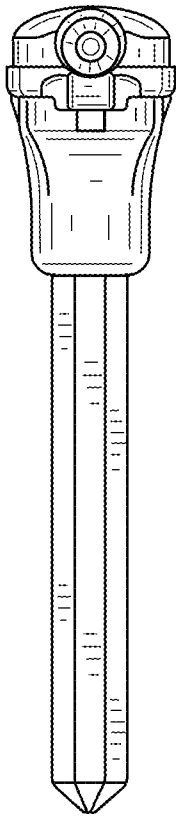

FIG. 13

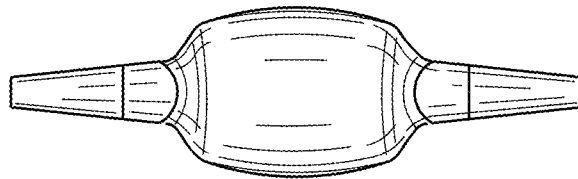

FIG. 14

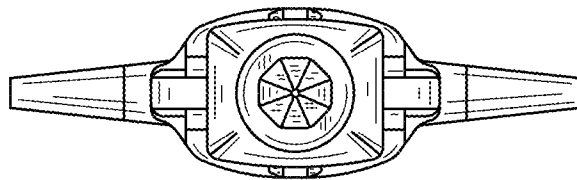

FIG. 15

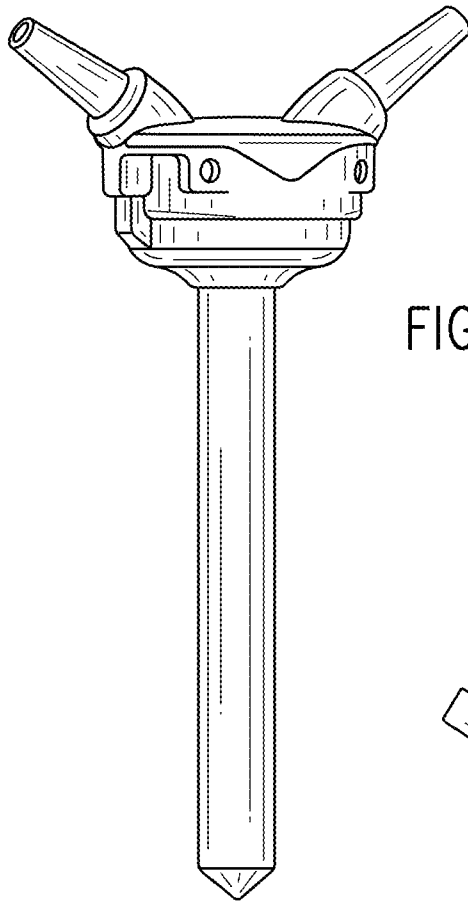

FIG. 16

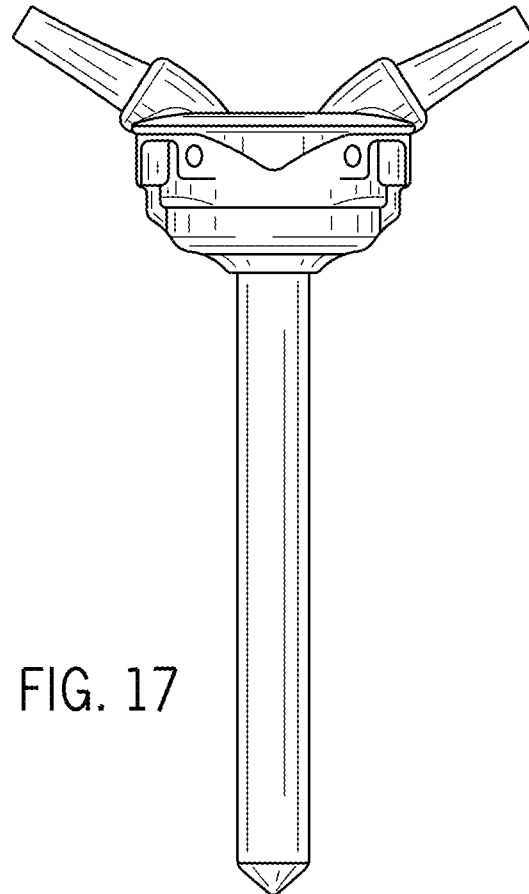

FIG. 17

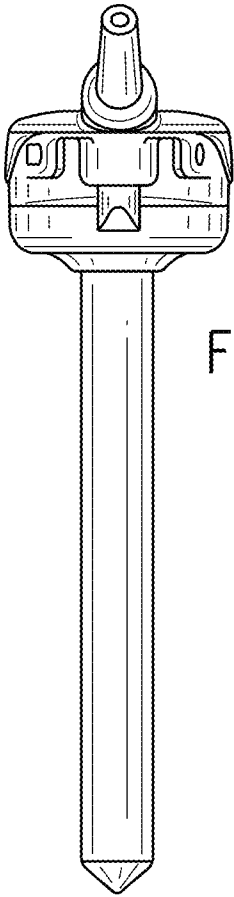

FIG. 18

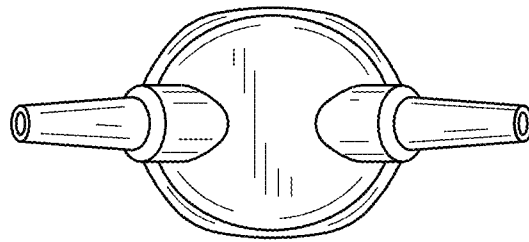

FIG. 19

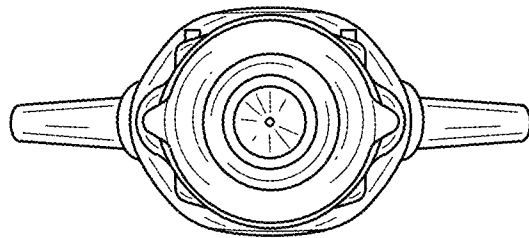

FIG. 20

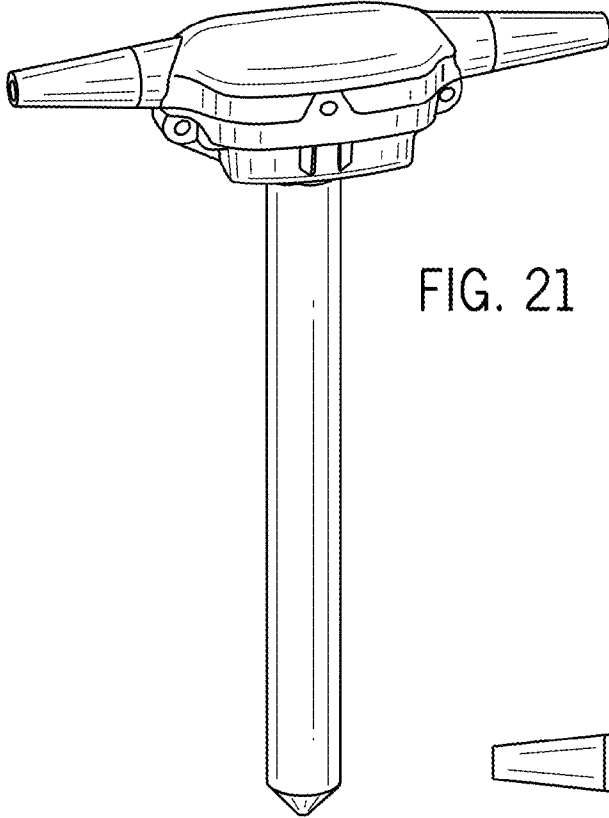

FIG. 21

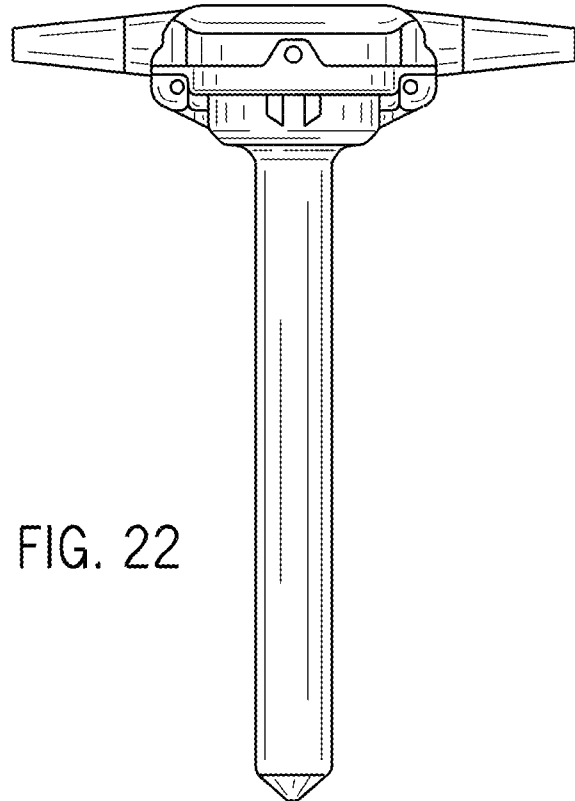

FIG. 22

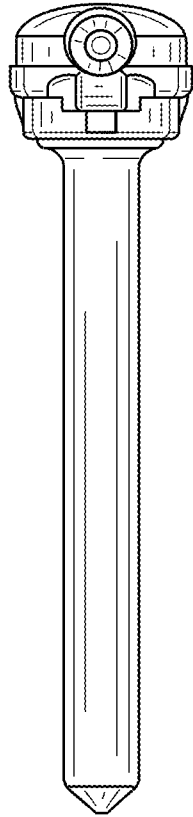

FIG. 23

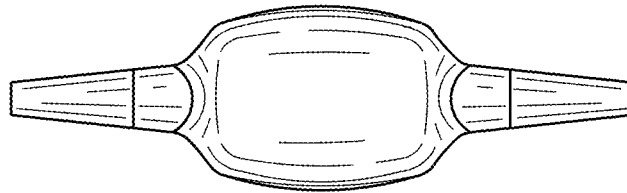

FIG. 24

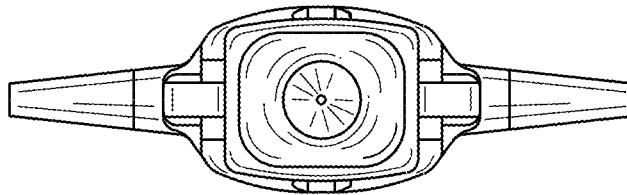

FIG. 25

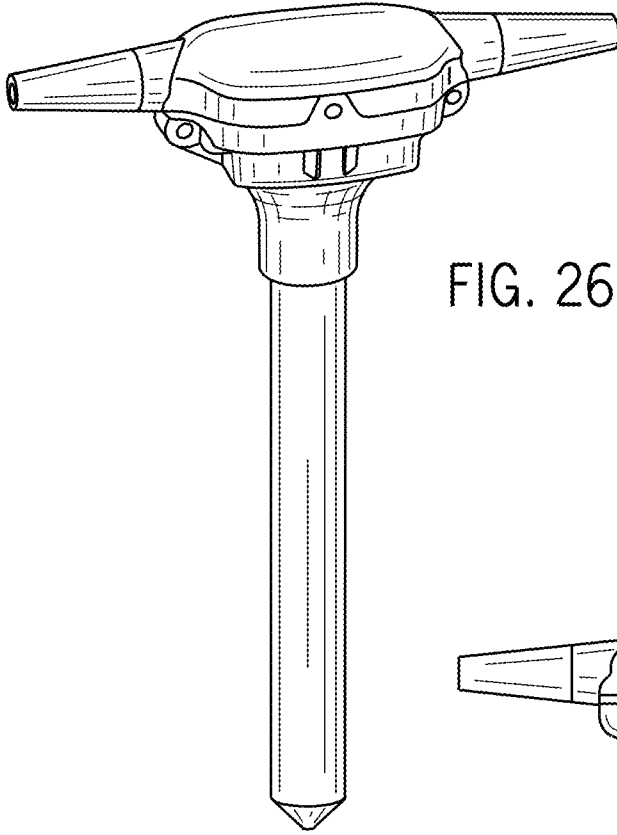

FIG. 26

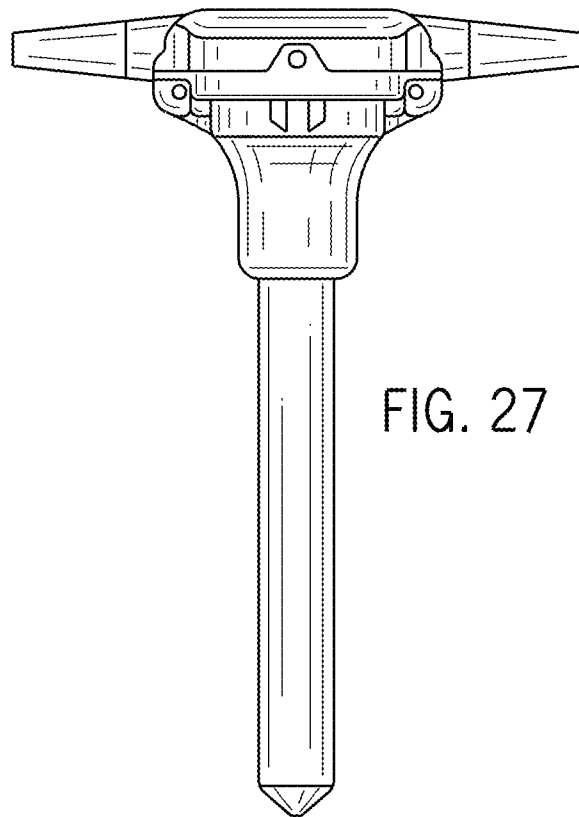

FIG. 27

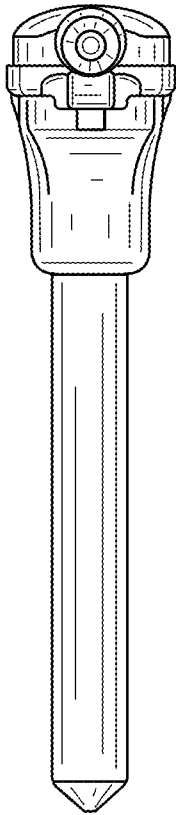

FIG. 28

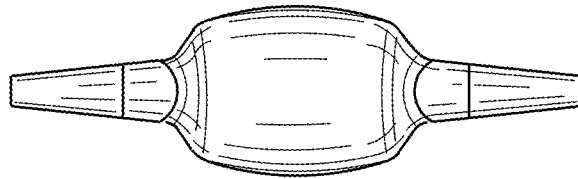

FIG. 29

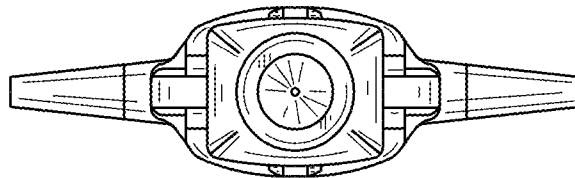

FIG. 30