



(12) **United States Design Patent**
Dayalan

(10) **Patent No.:** **US D892,899 S**
(45) **Date of Patent:** **** Aug. 11, 2020**

(54) **AUTOMOTIVE MONITORING CAMERA**

(71) Applicant: **Muthu Dayalan**, Charlotte, NC (US)

(72) Inventor: **Muthu Dayalan**, Charlotte, NC (US)

(**) Term: **15 Years**

(21) Appl. No.: **29/686,512**

(22) Filed: **Apr. 4, 2019**

(51) **LOC (12) Cl.** **16-01**

(52) **U.S. Cl.**
USPC **D16/208; D16/203**

(58) **Field of Classification Search**
USPC D16/200–204, 208, 218, 219;
D12/187–189, 400; 348/143, 148, 151,
348/360, 373–376; 396/419, 427–429,
396/433, 529, 535, 537–541; 340/932.2,
340/933, 937
CPC G03B 15/03; G03B 17/02; G03B 17/04;
G03B 17/48; G03B 17/56; G03B 19/04;
G08G 1/0175; H04N 5/2251; H04N
5/2252; H04N 5/2253; H04N 5/2254
See application file for complete search history.

(56) **References Cited**

U.S. PATENT DOCUMENTS

6,411,332 B1 *	6/2002	Whitby	H04N 5/2251 348/373
D511,352 S *	11/2005	Oliver	D16/203
D765,756 S *	9/2016	Liu	D16/203
D785,693 S *	5/2017	Kim	D16/202
D824,986 S *	8/2018	Bartram	D16/214

D824,988 S *	8/2018	Boling	D16/218
D836,699 S *	12/2018	Kim	D16/206
D849,107 S *	5/2019	Huang	D16/218
D855,678 S *	8/2019	Boling	D16/218
D855,681 S *	8/2019	Jacob	F16M 11/22 D16/219
D865,837 S *	11/2019	Hasegawa	D16/202
D881,255 S *	4/2020	Li	D16/202

* cited by examiner

Primary Examiner — Ramzi S Almatrahi

(57) **CLAIM**

The ornamental design for an automotive monitoring camera, as shown and described.

DESCRIPTION

FIG. 1 is a top, front and left perspective view of an automotive monitoring camera showing my new design; FIG. 2 is a bottom and front perspective view thereof; FIG. 3 is a front elevation view thereof; FIG. 4 is rear elevation view thereof; FIG. 5 is a right elevation view thereof; FIG. 6 is a left elevation view thereof; FIG. 7 is a top plan view thereof; FIG. 8 is a bottom plan view thereof; and, FIG. 9 is a top, front and left perspective view thereof, shown in a collapsed configuration. The broken lines depict portions of the automotive monitoring camera in which the design is embodied that form no part of the claimed design.

1 Claim, 9 Drawing Sheets

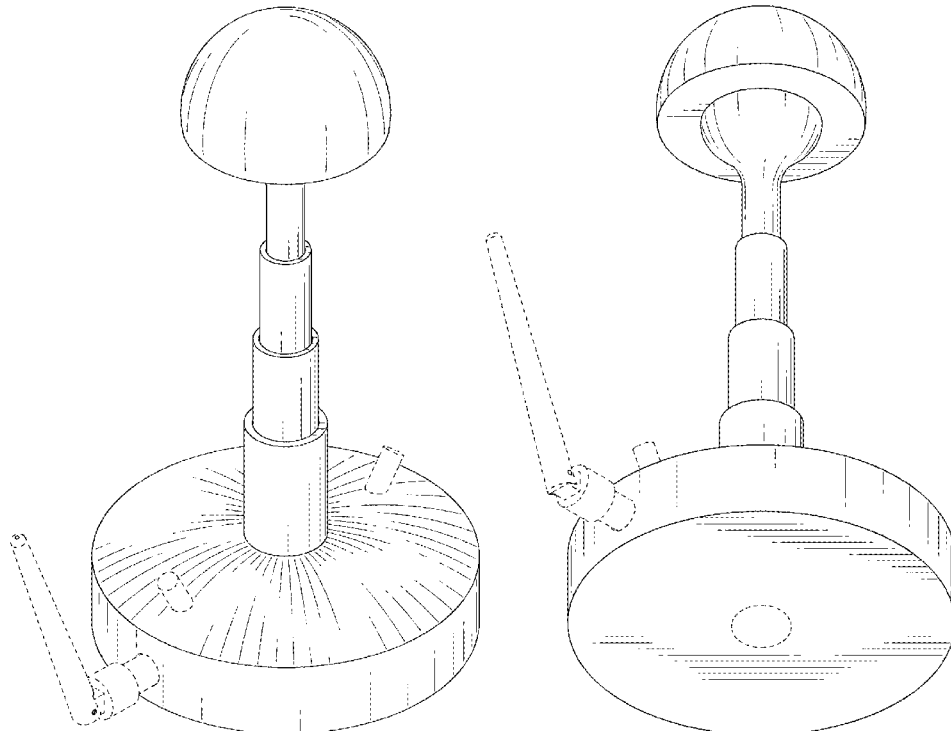

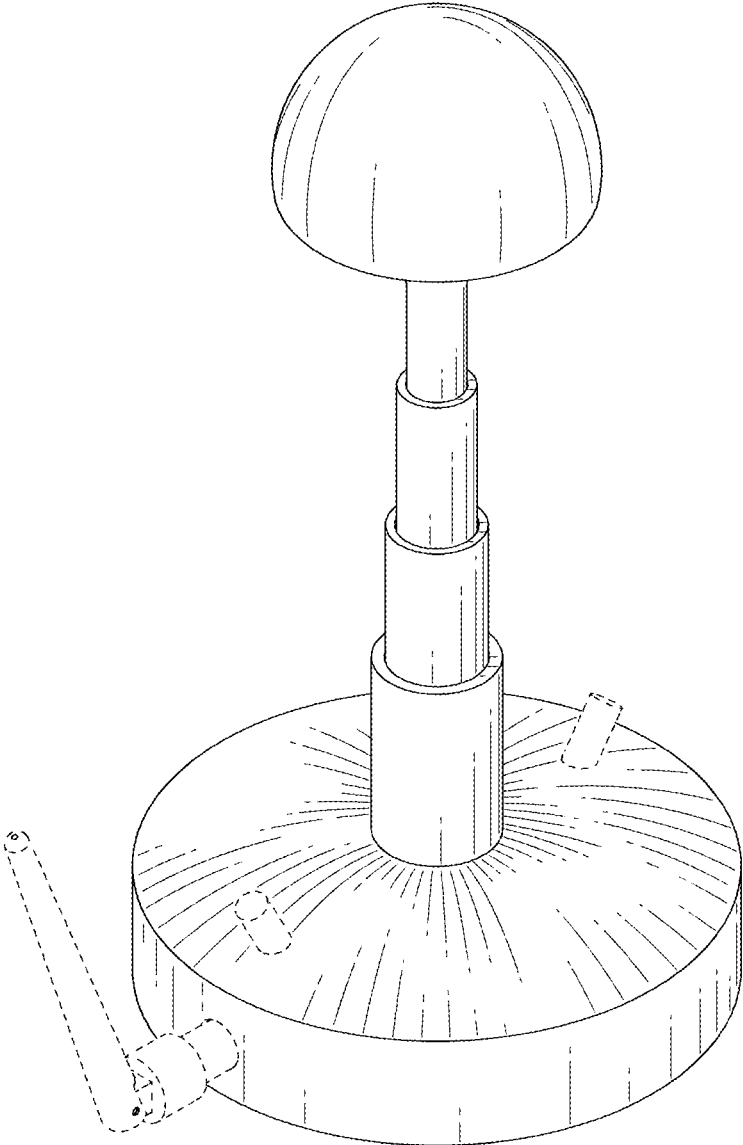

FIG. 1

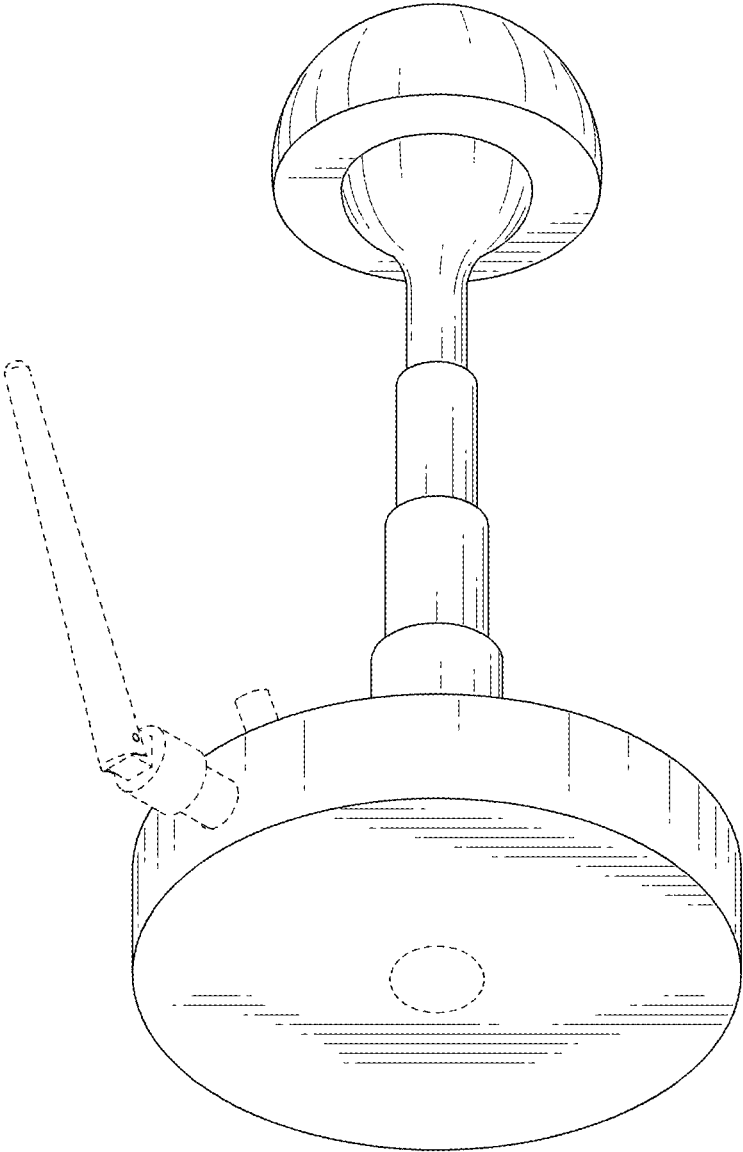

FIG. 2

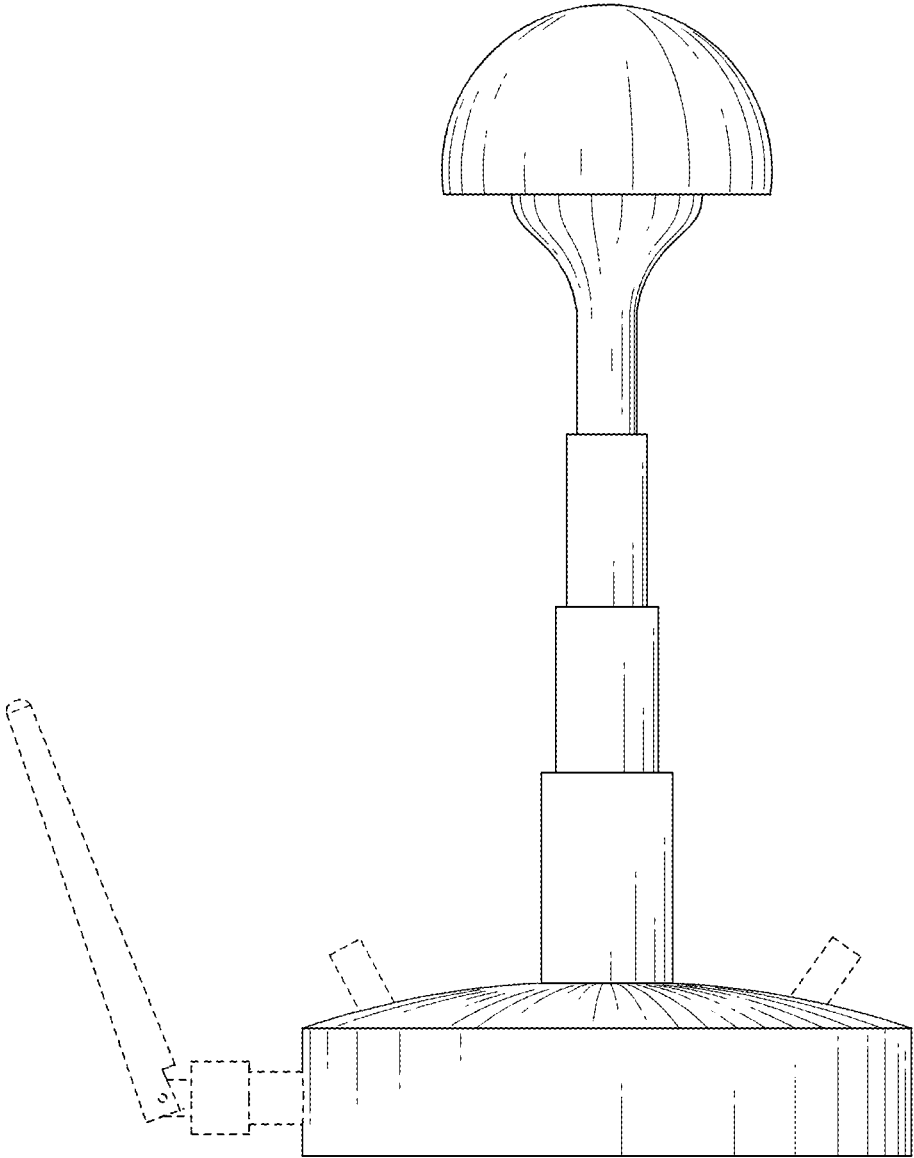

FIG. 3

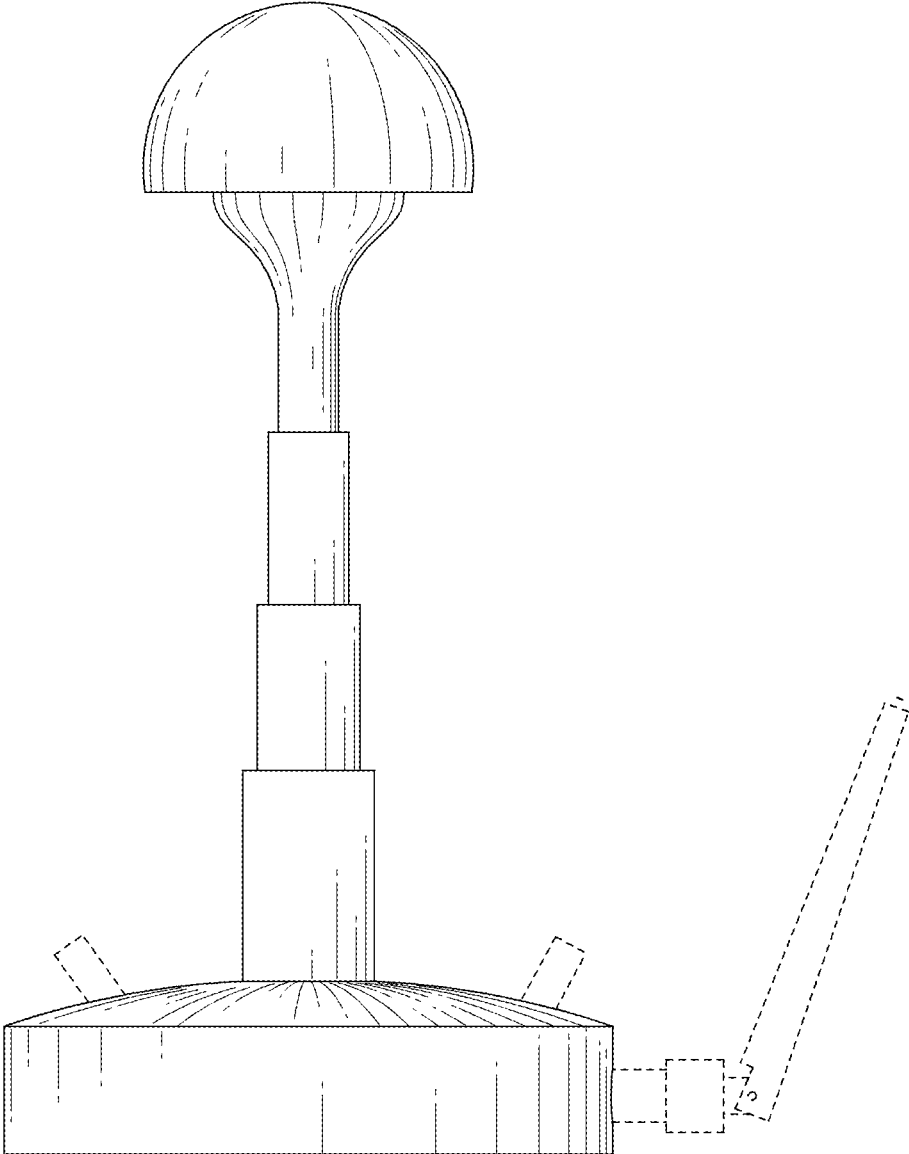

FIG. 4

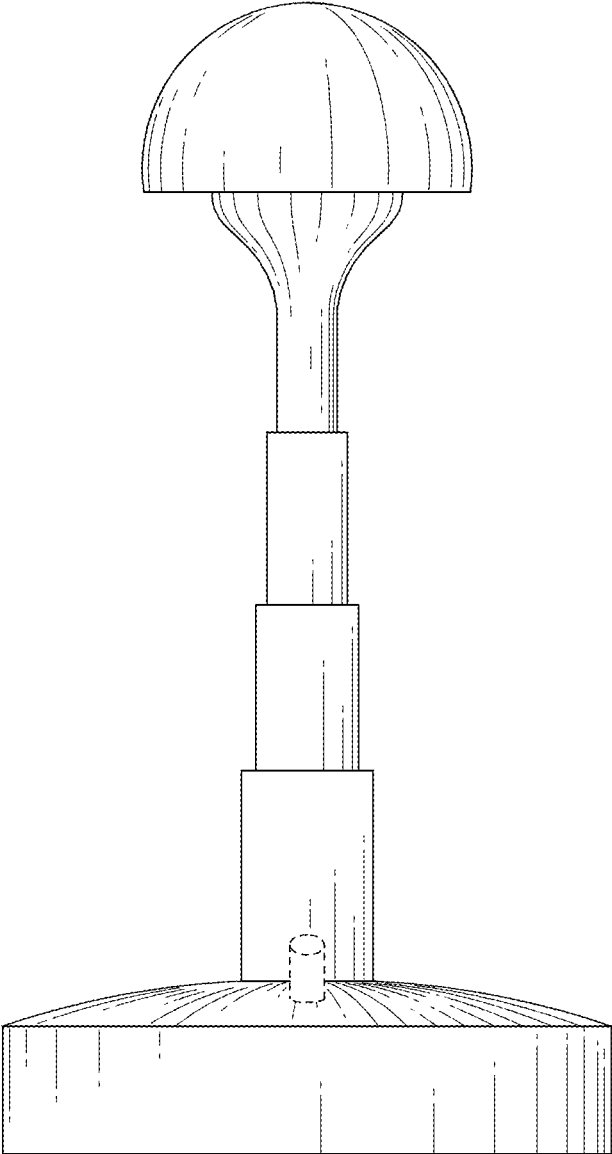

FIG. 5

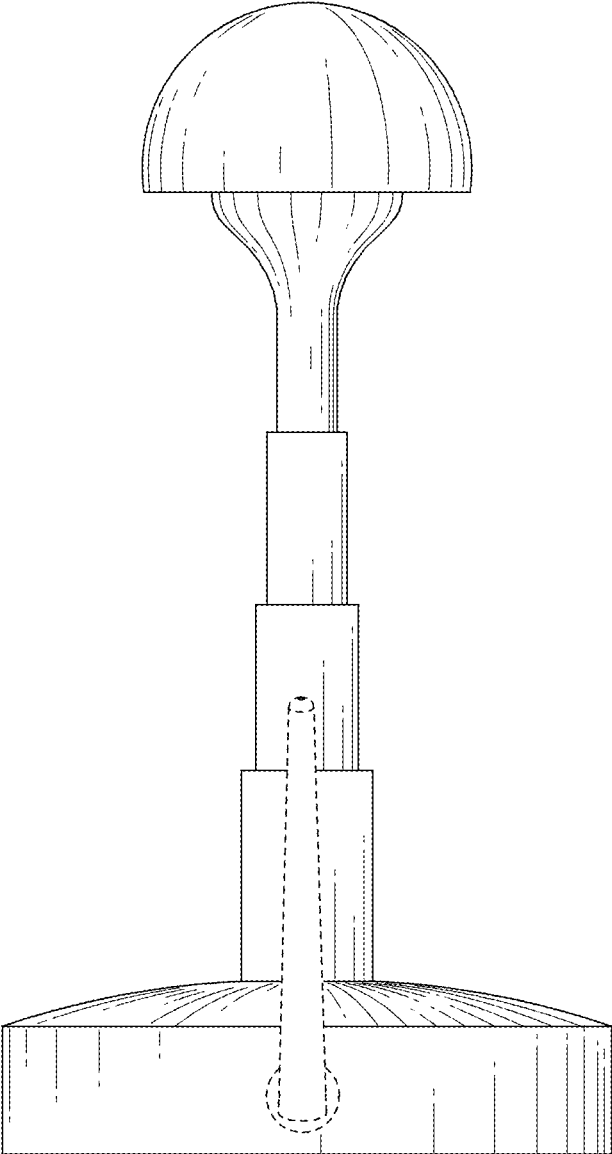

FIG. 6

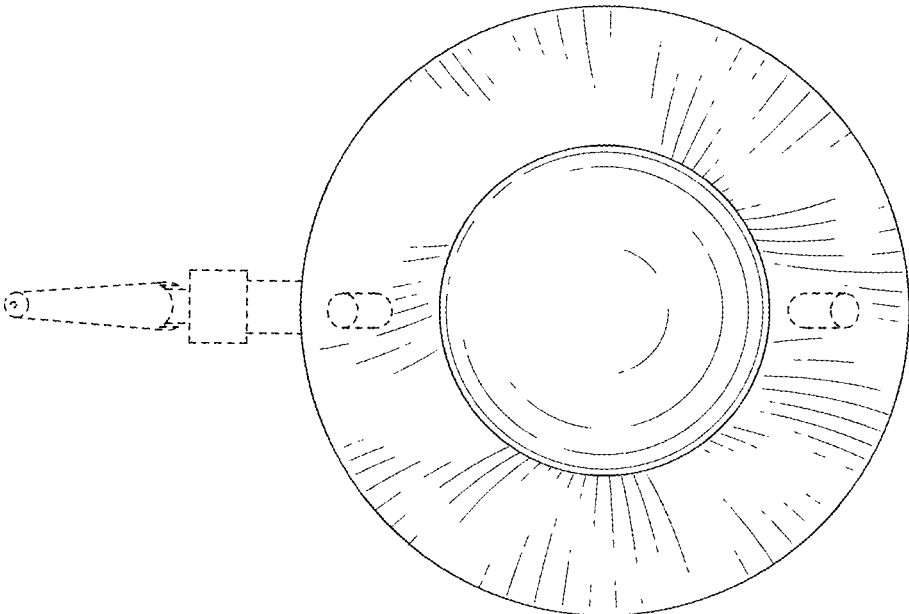

FIG. 7

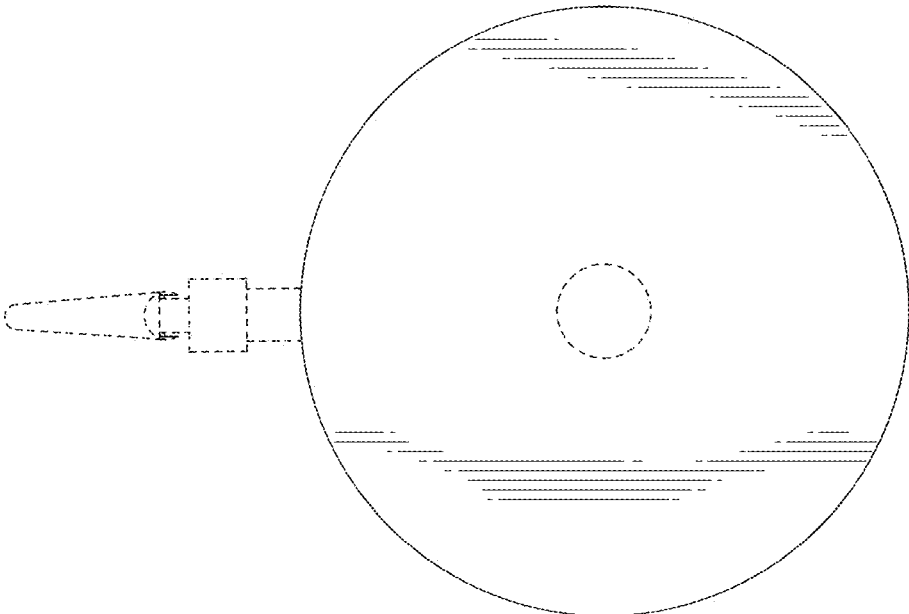

FIG. 8

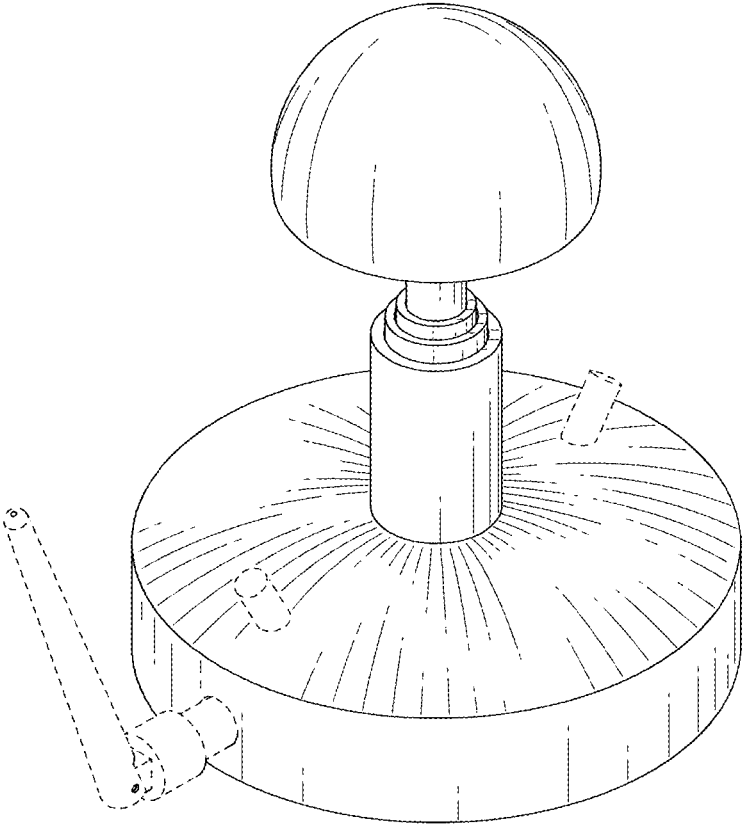

FIG. 9