

(12) INTERNATIONAL APPLICATION PUBLISHED UNDER THE PATENT COOPERATION TREATY (PCT)

(19) World Intellectual Property Organization  
International Bureau



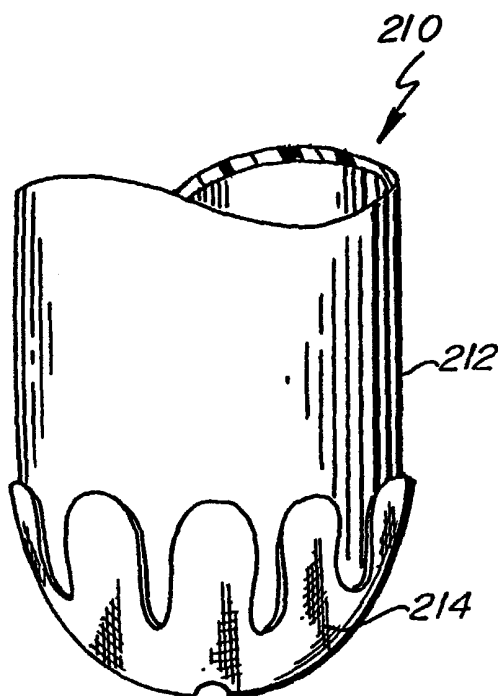
(43) International Publication Date  
29 March 2001 (29.03.2001)

PCT

(10) International Publication Number  
WO 01/21113 A2

- (51) International Patent Classification<sup>7</sup>: A61F 2/78, 2/80 (74) Agent: HELGET, Gerald, E.; Rider, Bennett, Egan & Arundel, 333 S. Seventh Street, Suite 2000, Minneapolis, MN 55402 (US).
- (21) International Application Number: PCT/US00/13613
- (22) International Filing Date: 18 May 2000 (18.05.2000) (81) Designated States (*national*): AU, CA, JP.
- (25) Filing Language: English (84) Designated States (*regional*): European patent (AT, BE, CH, CY, DE, DK, ES, FI, FR, GB, GR, IE, IT, LU, MC, NL, PT, SE).
- (26) Publication Language: English
- (30) Priority Data:  
09/399,708 21 September 1999 (21.09.1999) US  
Published:  
— Without international search report and to be republished upon receipt of that report.
- (71) Applicant: CASPERS-SCHNEIDER TECHNOLOGIES, INC., doing business as TEC INTERFACE SYSTEMS [US/US]; 820 Sundial Drive, Waite Park, MN 56387 (US).  
*For two-letter codes and other abbreviations, refer to the "Guidance Notes on Codes and Abbreviations" appearing at the beginning of each regular issue of the PCT Gazette.*
- (72) Inventor: CASPERS, Carl, A.; 33346 Shorewood Drive, Avon, MN 56310 (US).

(54) Title: PROSTHETIC LINER WITH DISTAL REINFORCEMENT



(57) Abstract: A prosthetic liner with a volume and shape for receiving a substantial portion of an amputee's residual limb and fitting in the space between the socket of an artificial limb and the residual limb with the liner donned on the residual limb, the liner having a distal portion adjacent the end of the residual limb. The liner has a flexible reinforcement member that is attachable to the distal portion to prevent the weight of the artificial limb, acting upon the liner, from compressing and stretching the residual limb. The reinforcement member preferably has a central portion centrally attached to the distal portion of the liner, and a peripheral portion extending radially outwardly from the central portion over the distal portion of the liner.

WO 01/21113 A2

## PROSTHETIC LINER WITH DISTAL REINFORCEMENT

**BACKGROUND OF THE INVENTION**

This application is a continuation-in-part of co-pending U.S. Patent Application Serial No. 09/115,053, filed July 15, 1998.

U.S. Patent Nos. 5,258,037 and 5,571,208 are herein incorporated by reference.

The present invention relates to prosthetic devices and more particularly to a distal cap for a prosthetic liner and socket.

An amputee is a person who has lost part of an extremity or limb such as a leg or arm that commonly may be termed as a residual limb. Residual limbs come in various sizes and shapes with respect to the stump. That is, most new amputations are either slightly bulbous or cylindrical in shape while older amputations that may have had a lot of atrophy are generally more conical in shape. Residual limbs may further be characterized by their various individual problems or configurations including the volume and shape of a stump and possible scar, skin graft, bony prominence, uneven limb volume, neuroma, pain, edema or soft tissue configurations.

Referring to FIG. 1, a below the knee residual limb 10 is shown and described as a leg 12 having been severed below the knee terminating in a stump 14. In this case, the residual limb 10 includes soft tissue as well as the femur 16, knee joint 18, and severed tibia 20 and fibula 22. Along these bony structures surrounded by soft tissue are nerve bundles and vascular routes that must be protected against external pressure to avoid neuromas, numbness and discomfort as well as other kinds of problems. A below the knee residual limb 10 has its stump 14 generally characterized as being a more bony structure while an above the knee residual limb may be characterized as including more soft tissue as well as the vascular routes and nerve bundles.

Referring to FIG. 2, amputees who have lost part of their arm 26, which terminates a stump 28 may also be characterized as having vascular routes, nerve bundles as well as soft and bony tissues. The residual limb 10 includes the humerus bone 30 that extends from below the shoulder to the elbow from which the radius 34 and ulna bones 36 may pivotally extend to the point of severance. Along the humerus bone 30 are the biceps muscle 38 and

the triceps muscle 40 which may still yet be connected to the radius 34 and the ulna 36, respectively.

In some respects, the residual limb amputee that has a severed arm 26 does not have the pressure bearing considerations for an artificial limb but rather is concerned with having an artificial limb that is articulable to offer functions typical of a full arm, such as bending at the elbow and grasping capabilities. An individual who has a paralyzed limb would also have similar considerations wherein he or she would desire the paralyzed limb to have some degree of mobility and thus functionality.

Historically, artificial limbs typically used by a leg amputee were for the most part all made of wood such as Upland Willow. The limbs were hand carved with sockets for receiving the stump 14 of the residual limb 10. Below the socket would be the shin portion with the foot below the shin. These wooden artificial limbs were covered with rawhide that was often painted. The sockets of most wood limbs were hollow as the limbs were typically supported in the artificial limb by the circumferential tissue adjacent the stump 14 rather than at the distal end of the stump 14.

Some artificial limbs in Europe were also made from forged pieces of metal that were hollow. Fiber artificial limbs were also used which were stretched around a mold after which they were permitted to dry and cure. Again, these artificial limbs were hollow and pretty much supported the residual limb about the circumferential tissue adjacent the stump 14.

All of these various artificial limbs have sockets to put the amputee's stump 14 into. There are generally two categories of sockets. There are hard sockets wherein the stump goes right into the socket actually touching the socket wall without any type of liner of stump sock. Another category of sockets is a socket that utilizes a liner or insert. Both categories of sockets typically were open-ended sockets which had a hollow chamber in the bottom and no portion of the socket touched the distal end of the stump 14. The stump was supported about its circumferential sides as it fit against the inside wall of the sockets.

These types of sockets caused a lot of shear force on the stump 14 as well as having pressure or restriction problems on the nerve bundles and vascular flow of fluid by way of the circumferential pressure effect on the socket on the limb. This pressure effect could cause a

swelling into the ends of the socket where an amputee may develop severe edema and draining nodules at the end of the stump 14.

With time, prosthetists learned that by filling in the socket's hollow chamber and encouraging a more total contact with the stump and the socket, the swelling and edema problems could be lessened. However, the manner in which the artificial limb was suspended from the residual limb still caused swelling, edema, pooling of fluids, and stretch discomfort to the residual limb.

In the past, most artificial limbs were suspended from the amputee's body by some form of pulley, belt or strap suspension often used with various harnesses and perhaps leather lacers or lacings. An improvement on these earlier systems is referred to as the shuttle system or a mechanical hookup or linkup wherein a thin suction liner is donned over the stump and the liner has a docking device on the distal end which mechanically links up with its cooperative part in the bottom of the socket chamber. An example of such a shuttle system is found in U.S. Patent No. 5,507,834.

These shuttle systems had serious drawbacks for the amputee. As shown in Fig. 5, the suction liner produces a kind of Chinese finger trap action when the weight of the artificial limb pulls on the liner. That is, when the amputee is standing on the artificial limb (phantom lines), weight bearing forces the limb to take the shape of the socket. As the amputee begins to walk and goes into swing phase where the body's weight is off the artificial limb, gravity acts on the artificial limb and the attached suction liner L. The liner L, which is typically a somewhat collapsible tube with flexible walls and a closed chamber, has a tendency to draw the soft tissue at the end of the stump 14 toward the artificial limb, as shown by the downward arrow, causing the soft tissue to elongate and the residual limb to narrow. Also, the liner has a tendency to begin to stretch downwardly and as this occurs there is a compression inwardly as shown by arrows C. This also causes a pumping action which causes fluid to be drawn into the elongated and narrowed portion of the residual limb. Then, when the amputee goes back in to weight bearing phase, the soft tissue that was just elongated and narrowed now becomes compressed. Over time, this alternating drawing and compression of the soft tissue causes fluid accumulation in the residual limb. This alternate compression and elongation also causes a shearing force on the skin which makes it

uncomfortable for some or many amputees to wear. The root of the problem is that the distal end of the liner changes shape from the weight-bearing phase to the swing phase.

In the past, attempts have been made to prevent the above effect by constructing the suction liner of material that stretches circumferentially but not longitudinally. Unfortunately, this helps but does not solve the problem. Applicant has found that the key to solving this problem is preventing the suction liner from collapsing at the distal end of the residual limb, thereby preventing the liner from narrowing and extending the soft tissue. As the result of extensive experimentation, Applicant has found that placing a semi-rigid tab or end cap on the distal end of the suction liner and carrying this cap partway up the residual limb eliminates the problem. The distal cap prevents the weight of the artificial limb from transferring draw to the end of the residual limb.

The distal end cap must simply be non-collapsing. It does not have to be rigid. The distal end cap may be constructed of any semi-rigid, non-collapsing material, including without limitation plastics, thermoplastics, urethanes, carbon fibers, or aluminum. The distal end cap may cover various portions of the residual limb, depending on the shape, bony structure, and volume of the residual limb. That is, in below the knee amputations, for example, the tissue in the distal end of the residual limb is primarily fluids. Closer to the knee joint, the tissue becomes more in the nature of ligaments, tendons, and white fiber. A limb with an extensive amount of soft tissue, for example, four inches, would probably require the distal cap to extend from the distal end of the residual limb and encompass all of the soft tissue. On the other hand, a residual limb that is more bony with less soft tissue would require a shorter distal cap.

The distal end cap system of the present invention has advantages over earlier systems that used a double wall socket with a suspension sleeve that holds the inner socket to the residual limb. In such systems, the suspension sleeve is stretched over the top of the inner socket. As the leg goes from flexion to extension, the sleeve also has to stretch over the side walls of the socket, which tend to interfere with movement or to create more effort in bending the knee. Also, the knee is an eccentric joint that doesn't have a common center so that as the leg is moved from straight extended to 90° flexion or further, the diameter and shape of the knee changes rather dramatically and the internal socket is quite rigid and doesn't accommodate that motion. There is some displacement created or pressure created because

of that shape change that is not accommodated well when the internal socket encompasses the whole knee capsule area. In contrast, the system of the present invention eliminates this displacement and pressure because only the suction liner comes up over the knee and allows for a more normal range of motion without the levering effects of the side walls of the inner socket. Simply put, the liner acts more like skin that flexes when the knee does.

There is a need for a distal cap prosthesis liner with a mechanical hookup to a socket that prevents elongation and narrowing of the residual limb.

### **SUMMARY OF THE INVENTION**

A prosthetic liner with a volume and shape for receiving a substantial portion of an amputee's residual limb and fitting in the space between the socket of an artificial limb and the residual limb with the liner donned on the residual limb, the liner having a distal portion adjacent the end of the residual limb. The liner has a flexible reinforcement member that is attachable to the distal portion to prevent the weight of the artificial limb, acting upon the liner, from compressing and stretching the residual limb. The reinforcement member preferably has a central portion centrally attached to the distal portion of the liner, and a peripheral portion extending radially outwardly from the central portion over the distal portion of the liner.

A principal object and advantage of the present invention is that it prevents elongation and narrowing of the distal end of the residual limb due to the weight of the artificial limb pulling on the socket liner.

Another principal object and advantage of the present invention is that it prevents the build-up of fluids in the distal end of the residual limb due to the drawing effect of the weight of the artificial limb on the socket liner.

Another object and advantage of the present invention is that it prevents a shearing effect on the skin of the distal end of the artificial limb due to the drawing effect of the weight of the artificial limb on the socket liner.

Another object and advantage of the present invention is that the height of the reinforcement member can be varied to accommodate the structure of the residual limb.

Another object and advantage of the present invention is that it may be permanently attached to the socket liner.

### **BRIEF DESCRIPTION OF THE DRAWINGS**

FIG. 1 is a side elevational view of the tissue and skeletal structure of an amputee's residual limb.

FIG. 2 is a side elevational view of a residual limb in the form of an amputated arm showing the skeletal and muscular structure of the residual limb.

FIG. 3 is a perspective view of a reduced positive model of the socket as described in U.S. Patent No. 5,258,037.

FIG. 4 is a perspective view of a liner produced as described in U.S. Patent No. 5,258,037.

FIG. 5 shows a prior art liner with shuttle system attached to a residual limb, and showing the elongation forces exerted upon the residual limb as the wearer moves the artificial limb between swing phase and weight-bearing phase (shown in phantom).

FIG. 6 is a schematic cross-section of a first embodiment of a distal end cap of the present invention.

FIG. 7 illustrates how the distal end cap of FIG. 6 is heated, molded, and attached to the liner which in turn is in place on a reduced positive mold of the residual limb.

FIG. 8 illustrates further the process of FIG. 7, with the distal end cap now being conformed to the shape of the residual limb.

FIG. 9 shows the completed model ready for manufacture of the socket, with the distal end cap completely conformed to the shape of the residual limb and the valve and docking system removed.

FIG. 10 shows the completed artificial limb with the liner and distal end cap shown in phantom and with structure broken away to show the docking system.

FIG. 11 is a perspective view of the complete socket system in place on the residual limb, with some structure broken away to show internal components.

FIG. 12 is a schematic cross-section of a second embodiment of the distal end cap of the present invention.

FIG. 13 shows the embodiment of FIG. 12 in place on the residual limb.

FIG. 14 illustrates attachment of the distal end cap to the socket by means of a Velcro strap.

FIG. 15 illustrates attachment of the distal end cap to the socket by means of a lanyard and cleat.

FIG. 16 is a cross-section along the lines 16 of FIG. 11.

FIG. 17 is a plan view of the distal reinforcement member of the present invention.

FIG. 18 is a side elevational view of the liner of the present invention with the distal reinforcement member attached.

FIG. 19 is a cross-sectional view of the liner of the present invention, including a docking member, with the distal reinforcement member attached to the liner.

FIG. 20 is a plan view of another embodiment of the distal reinforcement member of the present invention.



FIG. 21 is a plan view of another embodiment of the distal reinforcement member of the present invention.

FIG. 22 is a plan view of another embodiment of the distal reinforcement member of the present invention.

FIG. 23 is a cross-sectional view of the distal reinforcement member before application to the liner.

### **DETAILED DESCRIPTION OF THE PREFERRED EMBODIMENTS**

The distal end cap of the present invention is generally designated in the Figures as reference numeral 110.

As best seen in Fig. 6, a first embodiment of the distal end cap 110 comprises a cap portion 112 constructed of a semi-rigid, non-collapsing material adapted to sustain the diameter of the residual limb without collapsing under load, and a docking portion 114 for connecting to the artificial limb socket.

The cap portion 112 may be made of any semi-rigid, non-collapsing material including, without limitation, plastics, thermoplastics, urethanes, carbon fibers, or aluminum.

Preferably, the cap portion 112 is moldable to the shape of the distal end of the residual limb, as will be further discussed below.

The height H of the cap portion need only be enough to enclose the distal end of the residual limb. The height H may be higher when the residual limb has a lot of soft tissue, as in above the knee (AK) residual limb, and the height H may be less when the residual limb is more bony, as in a below the knee (BK) residual limb.

The first embodiment of the distal end cap 110 is permanently attached to the liner L, preferably by an adhesive, as discussed below. Fig. 6 shows the distal end cap 110 before attachment to the liner. Figs. 7, 8, and 9 show the manufacturing process for an artificial limb socket incorporating the distal end cap 110. It will be understood that Figs. 7 and 8 also show the process of manufacturing the distal end cap embodiment attached to the liner.

A second embodiment of the distal end cap 110 of the present invention is shown in Figs. 12 and 13. In this embodiment, the distal end cap 110 is not permanently attached to the liner L. Rather, the distal end cap 110 has a suspension sleeve S (discussed in U.S. Patent No. 5,571,208 and herein incorporated by reference) attached to the cap portion 112. As can be seen in Fig. 12, the wearer dons the distal end cap 110 with the suspension sleeve S rolled downwards about the cap portion 112. Then, as shown in Fig. 13, the suspension sleeve S is rolled upward over the liner L and the residual limb 14, so that the suspension sleeve S “tacks up” to the residual limb 14 as previously discussed in U.S. Patent No. 5,571,208. In this embodiment, the wearer has the option of replacing the liner L if it becomes soiled or damp with perspiration.

The distal end cap 110 may also preferably include a one-way valve 116 traversing the distal end cap 110 and adapted to evacuate air from the liner L as the wearer dons the liner. As shown in Fig. 6, the valve 116 may traverse the cap portion 112, in which case it is shown as 116a. Alternatively, the valve 116 may traverse the docking portion 114 in which case it is shown as 116b.

The docking portion 114 preferably further comprises a mechanical interlocking linkage 114a releasably connecting the distal end cap 110 and the socket 104, as shown in Fig. 11. The Figures show the mechanical interlocking linkage 114a as a cylindrical member with a number of ratchets therealong, for connecting to an appropriate orifice (not shown) in the socket 104. However, it will be recognized that any equivalent mechanical interlocking linkage may be used, as for example the ring 128 and pin disclosed in U.S. 5,258,037 or a smooth cylindrical member (not shown) with a cotter pin inserted therethrough. The function of the docking portion 114 is to hold the distal end cap 110 to the socket 104, and any equivalent structure which accomplishes this task may be used.

As additional security, or as a replacement for the mechanical interlocking linkage 114a, the distal end cap 110 may include a strap 118 attached to the distal end cap 110 at one end and to the socket 104 at the other end of the strap, as seen in Figs. 14 and 15. In Fig. 14, the strap 118 has a hook-and-loop fastener 118b attached to one end of the strap 118 and a matching hook-and-loop fastener 118a attached to the socket 104. The strap 118 feeds out of the socket 104 through an opening 122. In Fig. 15, the strap 118 attaches to the socket 104 by means of wrapping around a cleat 124.

The distal end cap 110 may also include an alignment system 130 for aligning the docking system 114 and valve 116 with corresponding structures in the socket 104. Although any equivalent mechanism could be used, the alignment system 130 may preferably comprise a tab, tongue, or protrusion 132 which mates with a groove or slot 134 in the wall of the socket 104.

The process of constructing a liner and socket as used in the present invention is described in U.S. Patent No. 5,258,037, herein incorporated by reference. The construction process as discussed in U.S. Patent No. 5,258,037 is modified as follows to construct the present invention.

After the liner (Fig. 4) is constructed on a reduced positive model of the residual limb (Fig. 3), as described in Col. 1 through Col. 8 line 62 of U.S. Patent No. 5,258,037, the distal end cap 110 of the present invention is placed upon the liner L which is in turn placed on the reduced positive model M as shown in Fig. 7. Heat is then suitably applied to conform the distal end cap 110 to the shape of the residual limb, as for example by a heat gun as shown in Fig. 7. As the distal end cap 110 is heated and pressed onto the model M and liner L, the distal end cap 110 conforms to the shape of the residual limb as shown in Fig. 8. Suitably, adhesive A (Fig. 7) may be placed within the distal end cap 110 during this process to secure the distal end cap 110 to the liner L. After the distal end cap 110 is securely attached to the liner L, the valve V and docking shuttle S may be removed from the distal end cap, as shown in Fig. 9

The construction process then continues as described in U.S. Patent No. 5,258,037. It will be recognized that because the distal end cap 110 is in place on the model M, space will be left in the negative model of the socket to accommodate a distal end cap 110 when it is later donned by the wearer. The end result of the construction process is the artificial limb shown in Fig. 10. The artificial limb includes a socket 104, shin 106, and foot 108.

A prosthetic liner with flexible reinforcement member is generally shown in the Figures as reference numeral 210. Applicant has found that the reinforcement member may act equivalently as the distal end cap 110 for most applications.

The prosthetic liner 210 may appropriately be a liner as disclosed in U.S. Patent No. 5,534,034, herein incorporated by reference.

The prosthetic liner 210, as disclosed in U.S. 5,534,034, suitably has a volume and a shape for receiving a substantial portion of an amputee's residual limb and fitting in the space between the socket of an artificial limb and the residual limb with the liner donned on the residual limb, the liner having a distal portion 212 adjacent the end of the residual limb.

The prosthetic liner 210 of the present invention particularly comprises a flexible reinforcement member 214 attachable to the distal portion 212 to prevent the weight of the artificial limb, acting upon the liner, from compressing and stretching the residual limb, as disclosed above.

Preferably, the reinforcement member 214 further comprises a central portion 216 centrally attached to the distal portion 212 of the liner 210, and a peripheral portion 218 extending radially outwardly from the central portion 216 over the distal portion 212.

Most preferably, the peripheral portion 218 comprises a plurality of fingers 220 separated from one another by gaps 222.

In one embodiment, shown in Fig. 20, the fingers 220 are of uniform width  $W$  along their radial extent  $R$ .

In other embodiments, shown in Figs. 17 and 21, the fingers 220 increase in width  $W$ ,  $W'$  as they extend radially outwardly from the central portion 216.

In another embodiment, shown in Fig. 22, the reinforcement member 214 further comprises a pad 224 at the outermost portion 226 of each finger 220. Preferably, the pad 224 extends in an arc from one side of each finger 220 to the other side of each finger 220, as shown.

The reinforcement member 214 preferably comprises fabric 230, an adhesive 232 bonded to the fabric 230, and a removable backing paper 234 covering the adhesive. The backing paper 234 is removed for attaching the reinforcement member 214 to the liner 210 by

the adhesive 232. The adhesive 232 may be any adhesive, such as Scotch™ 9690 Laminating Adhesive from 3M, St. Paul, Minnesota 55144-1000.

As seen in Fig. 19, the prosthetic liner 210 may further comprise a docking member 240 at the distal portion 212, the docking member 240 being adapted to be connected to the artificial limb socket as discussed above. The docking portion 114 may suitably be connected to the docking member 240. In this embodiment, the reinforcement member 212 has a central opening 250 encompassing the docking member 240.

The present invention may be embodied in other specific forms without departing from the spirit or essential attributes thereof, and it is therefore desired that the present embodiment be considered in all respects as illustrative and not restrictive, reference being made to the appended claims rather than to the foregoing description to indicate the scope of the invention.

**WHAT IS CLAIMED:**

1. A prosthetic liner with a volume and shape for receiving a substantial portion of an amputee's residual limb and fitting in the space between the socket of an artificial limb and the residual limb with the liner donned on the residual limb, the liner having a distal portion adjacent the end of the residual limb, and further comprising a flexible reinforcement member attachable to the distal portion to prevent the weight of the artificial limb, acting upon the liner, from compressing and stretching the residual limb.

2. The prosthetic liner of claim 1, wherein the reinforcement member is attachable to the liner by an adhesive.

3. The prosthetic liner of claim 1, wherein the reinforcement member further comprises a central portion centrally attached to the distal portion of the liner, and a peripheral portion extending radially outwardly from the central portion over the distal portion of the liner.

4. The prosthetic liner of claim 3, wherein the peripheral portion further comprises a plurality of fingers separated from one another by gaps.

5. The prosthetic liner of claim 4, wherein the fingers are of uniform width along their radial extent.

6. The prosthetic liner of claim 4, wherein the fingers increase in width as they extend radially outwardly from the central portion.

7. The prosthetic liner of claim 4, further comprising a pad at the outermost portion of each finger.

8. The prosthetic liner of claim 7, wherein the pad extends in an arc from one side of each finger to the other side of each finger.

9. The prosthetic liner of claim 1, wherein the reinforcement member further comprises fabric, an adhesive bonded to the fabric, and a removable backing paper covering the adhesive, the backing paper being removed for attaching the reinforcement member to the liner by the adhesive.

10. The prosthetic liner of claim 1, further comprising a docking member at the distal portion adapted to be connected to the artificial limb socket, and wherein the reinforcement member has a central opening encompassing the docking member.

11. A prosthetic liner with a volume and shape for receiving a substantial portion of an amputee's residual limb and fitting in the space between the socket of an artificial limb and the residual limb with the liner donned on the residual limb, the liner having a distal portion adjacent the end of the residual limb, and further comprising a flexible reinforcement member attachable to the distal portion to prevent the weight of the artificial limb, acting upon the liner, from compressing and stretching the residual limb, wherein the reinforcement member further comprises a central portion centrally attached to the distal portion of the liner, and a peripheral portion extending radially outwardly from the central portion over the distal portion of the liner.

12. The prosthetic liner of claim 11, wherein the peripheral portion further comprises a plurality of fingers separated from one another by gaps.

13. The prosthetic liner of claim 12, wherein the fingers are of uniform width along their radial extent.

14. The prosthetic liner of claim 12, wherein the fingers increase in width as they extend radially outwardly from the central portion.

15. The prosthetic liner of claim 12, further comprising a pad at the outermost portion of each finger.

16. The prosthetic liner of claim 15, wherein the pad extends in an arc from one side of each finger to the other side of each finger.

17. The prosthetic liner of claim 11, wherein the reinforcement member further comprises fabric, an adhesive bonded to the fabric, and a removable backing paper covering the adhesive, the backing paper being removed for attaching the reinforcement member to the liner by the adhesive.

18. The prosthetic liner of claim 11, further comprising a docking member at the distal portion adapted to be connected to the artificial limb socket, and wherein the reinforcement member has a central opening encompassing the docking member.



19. A prosthetic liner with a volume and shape for receiving a substantial portion of an amputee's residual limb and fitting in the space between the socket of an artificial limb and the residual limb with the liner donned on the residual limb, the liner having a distal portion adjacent the end of the residual limb, and further comprising a flexible reinforcement member attachable to the distal portion to prevent the weight of the artificial limb, acting upon the liner, from compressing and stretching the residual limb, wherein the reinforcement member further comprises a central portion centrally attached to the distal portion of the liner, and a peripheral portion extending radially outwardly from the central portion over the distal portion of the liner, wherein the peripheral portion further comprises a plurality of fingers separated from one another by gaps.

20. The prosthetic liner of claim 19, wherein the fingers are of uniform width along their radial extent.

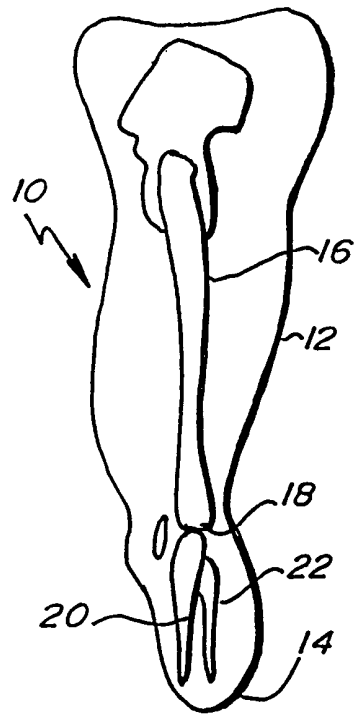
21. The prosthetic liner of claim 19, wherein the fingers increase in width as they extend radially outwardly from the central portion.

22. The prosthetic liner of claim 19, further comprising a pad at the outermost portion of each finger.

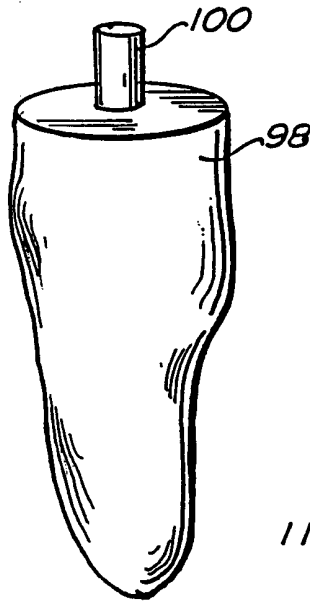
23. The prosthetic liner of claim 22, wherein the pad extends in an arc from one side of each finger to the other side of each finger.

24. The prosthetic liner of claim 19, wherein the reinforcement member further comprises fabric, an adhesive bonded to the fabric, and a removable backing paper covering the adhesive, the backing paper being removed for attaching the reinforcement member to the liner by the adhesive.

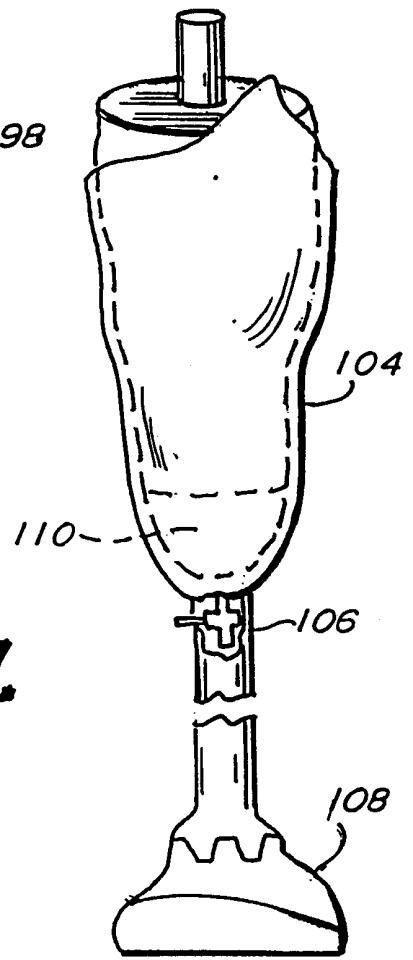
25. The prosthetic liner of claim 19, further comprising a docking member at the distal portion adapted to be connected to the artificial limb socket, and wherein the reinforcement member has a central opening encompassing the docking member.



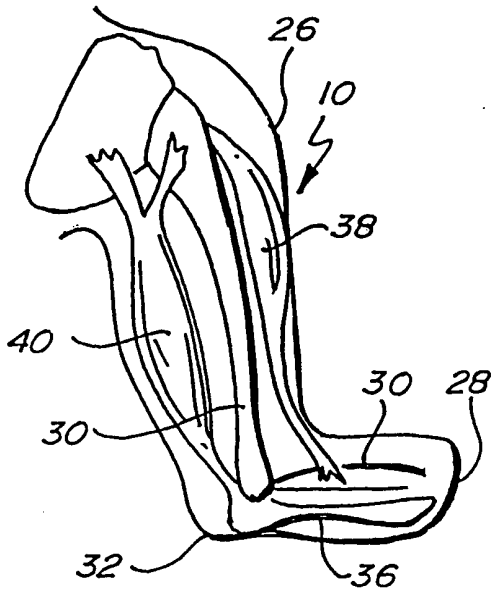
**Fig. 1.**



**Fig. 3.**



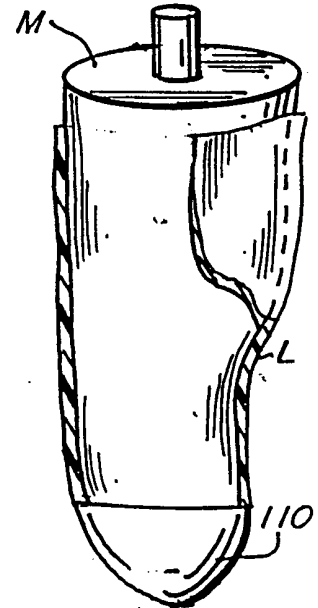
**Fig. 10.**



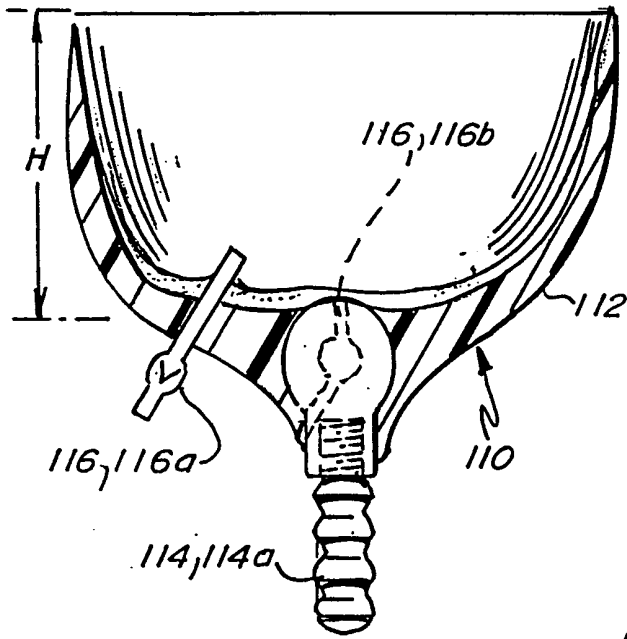
**Fig. 2.**



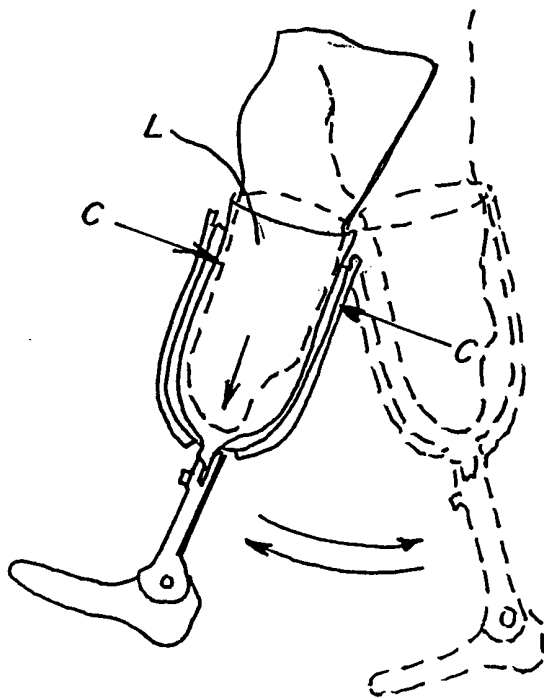
**Fig. 4.**



**Fig. 9.**

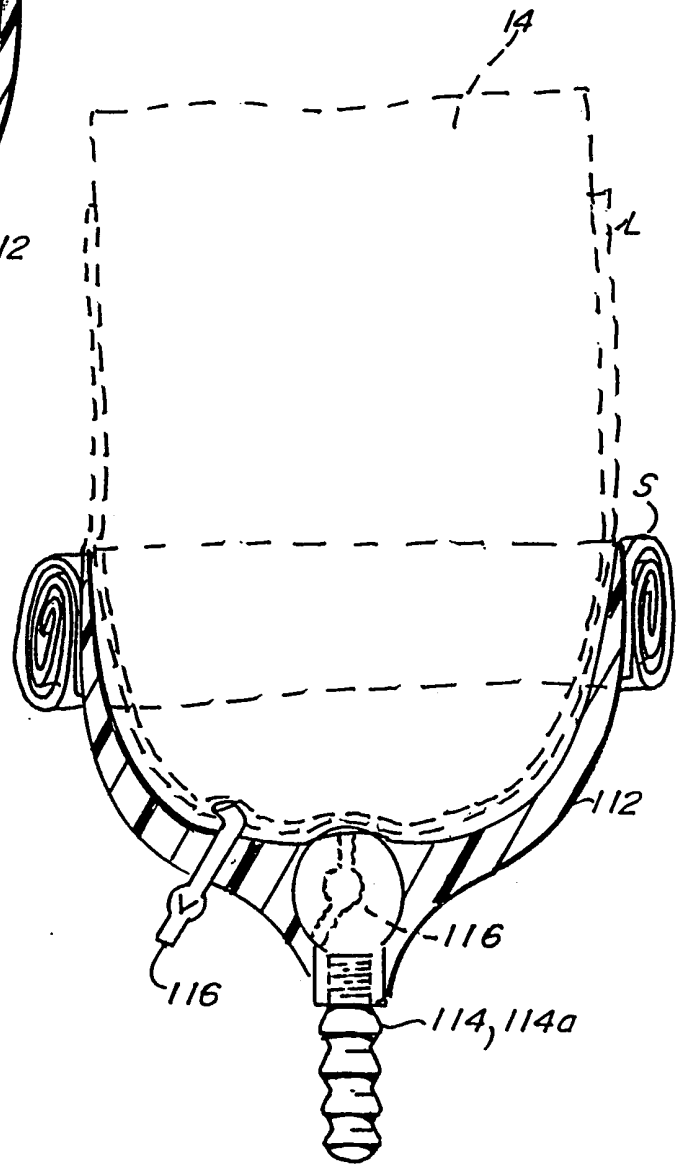


**Fig. 6.**

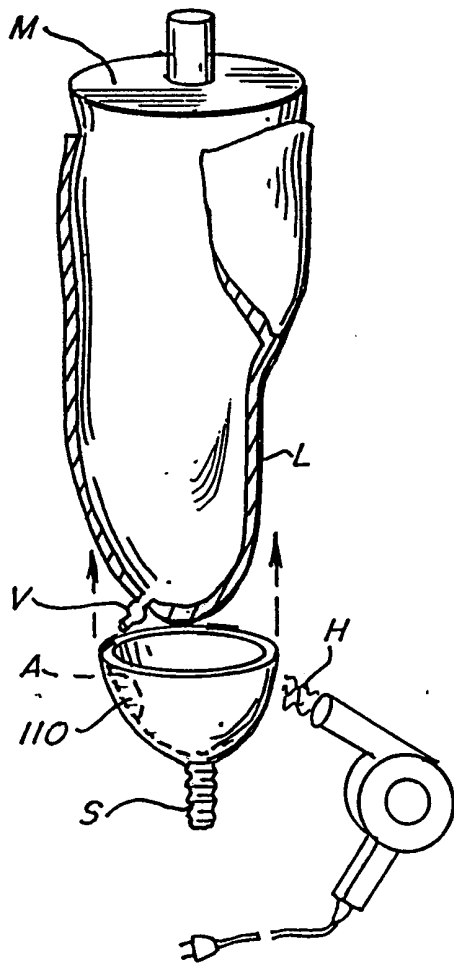


**Fig. 5.**

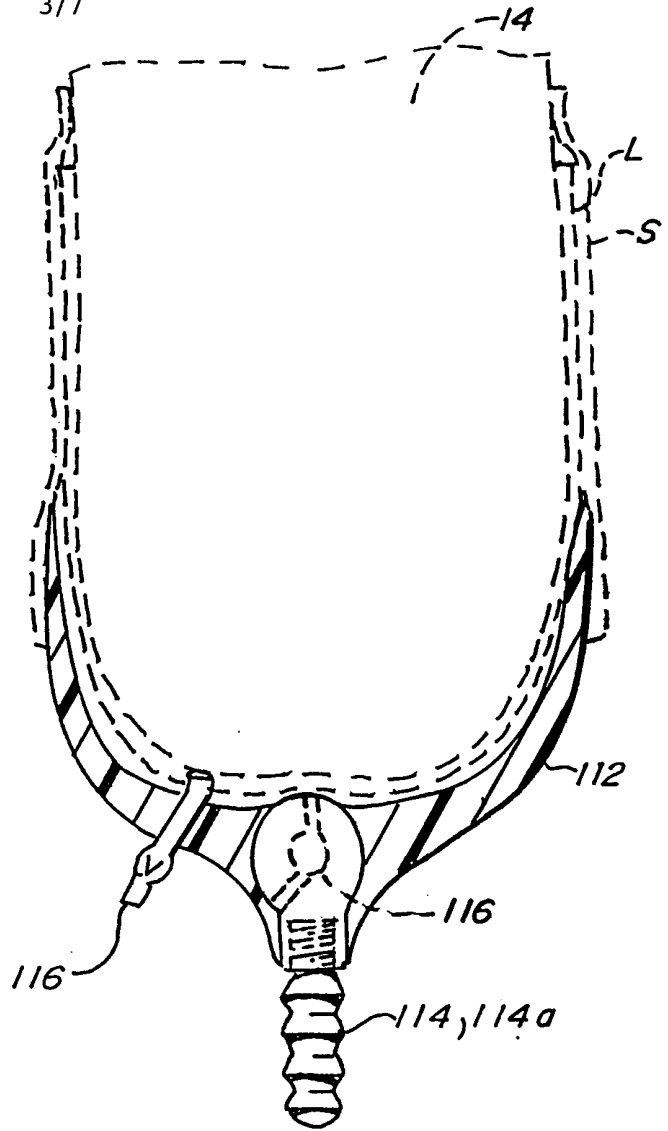
PRIOR ART



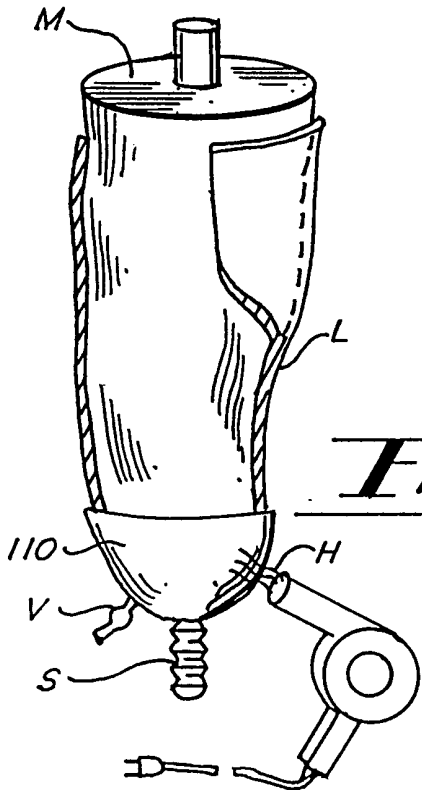
**Fig. 12.**



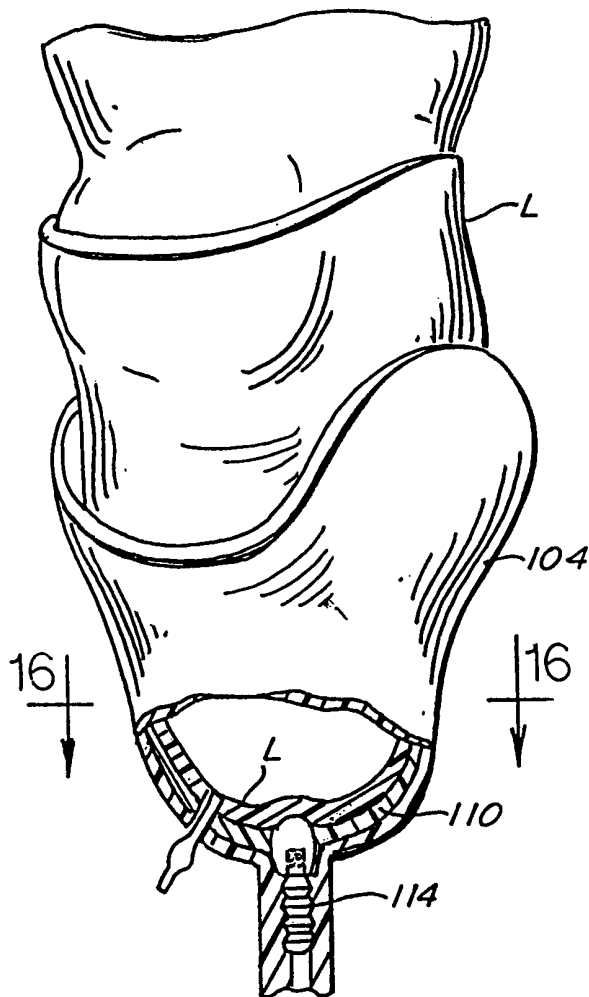
**Fig. 7.**



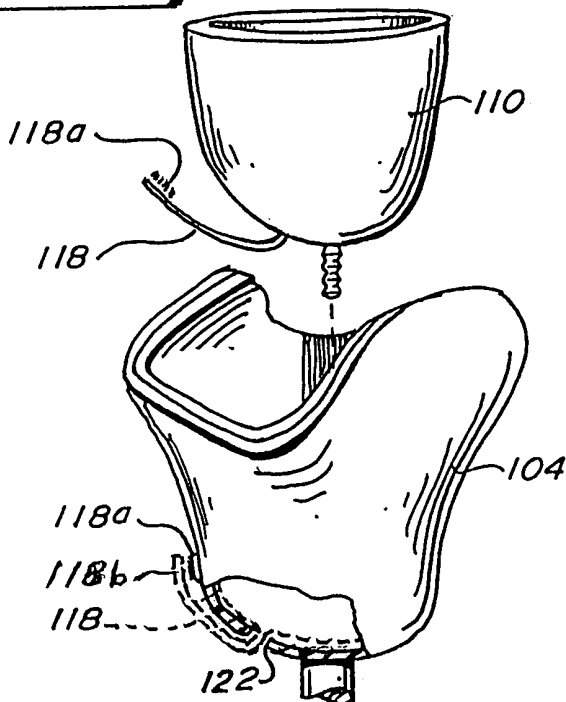
**Fig. 13.**



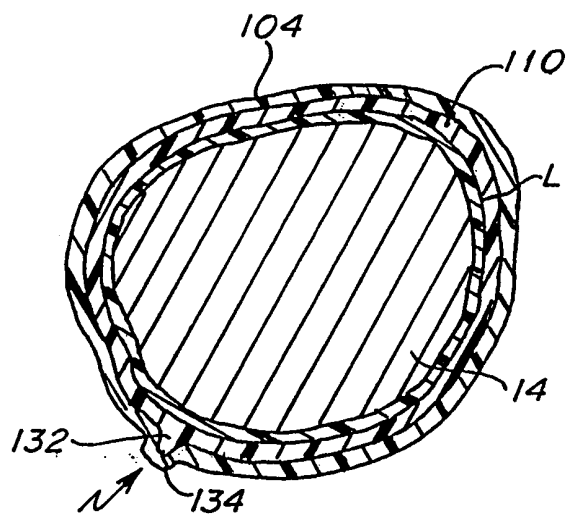
**Fig. 8.**



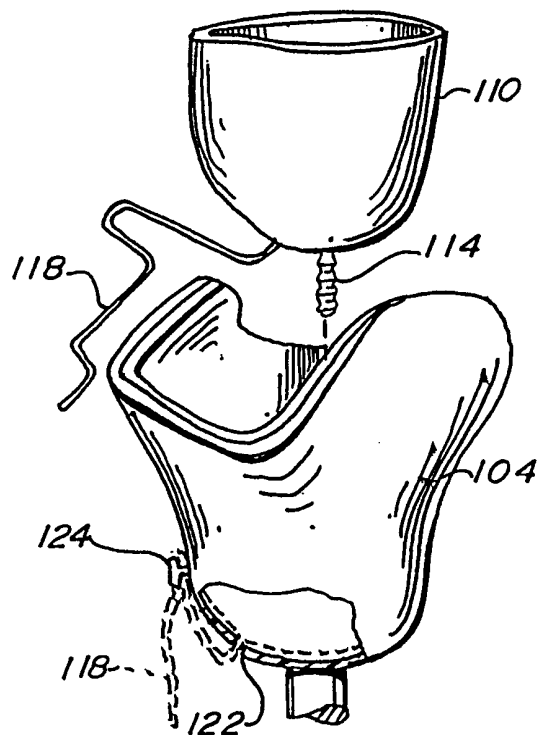
**Fig. 11.**



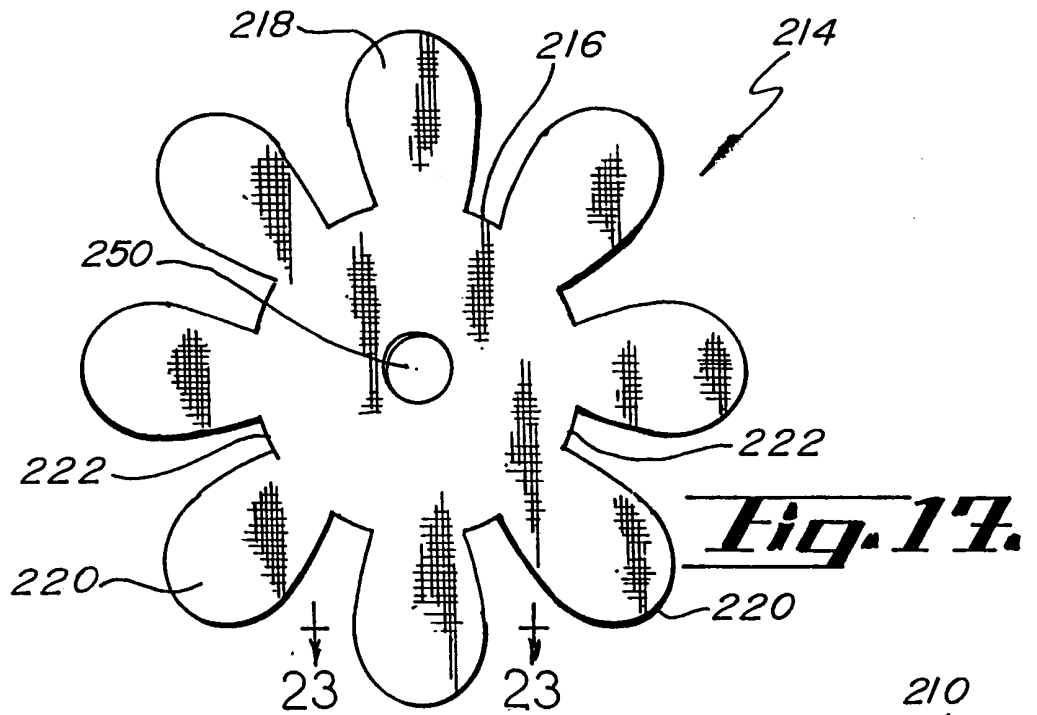
**Fig. 14.**



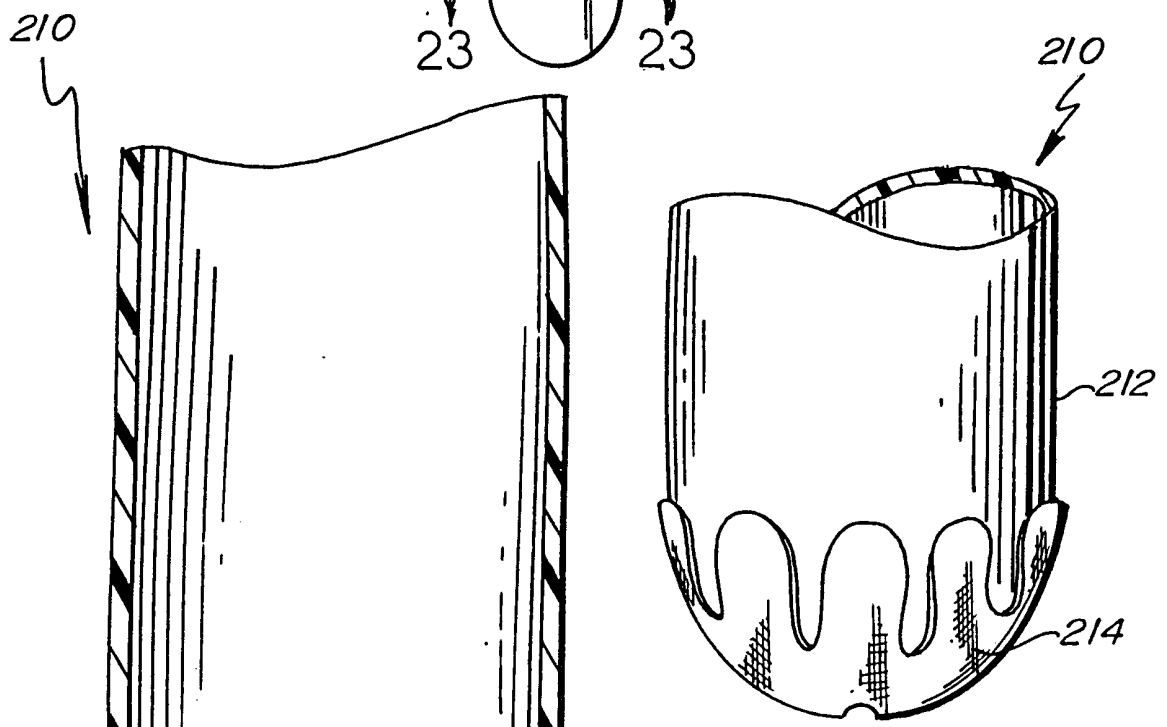
**Fig. 16.**



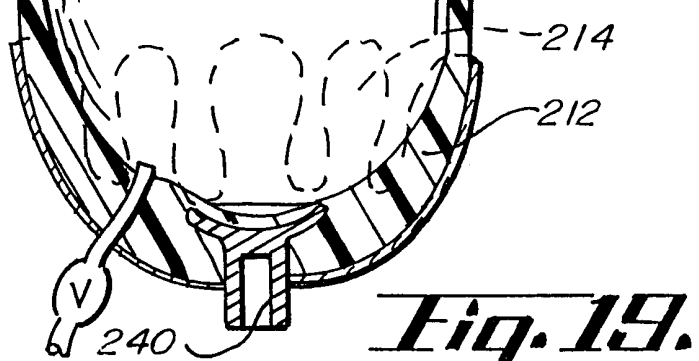
**Fig. 15.**



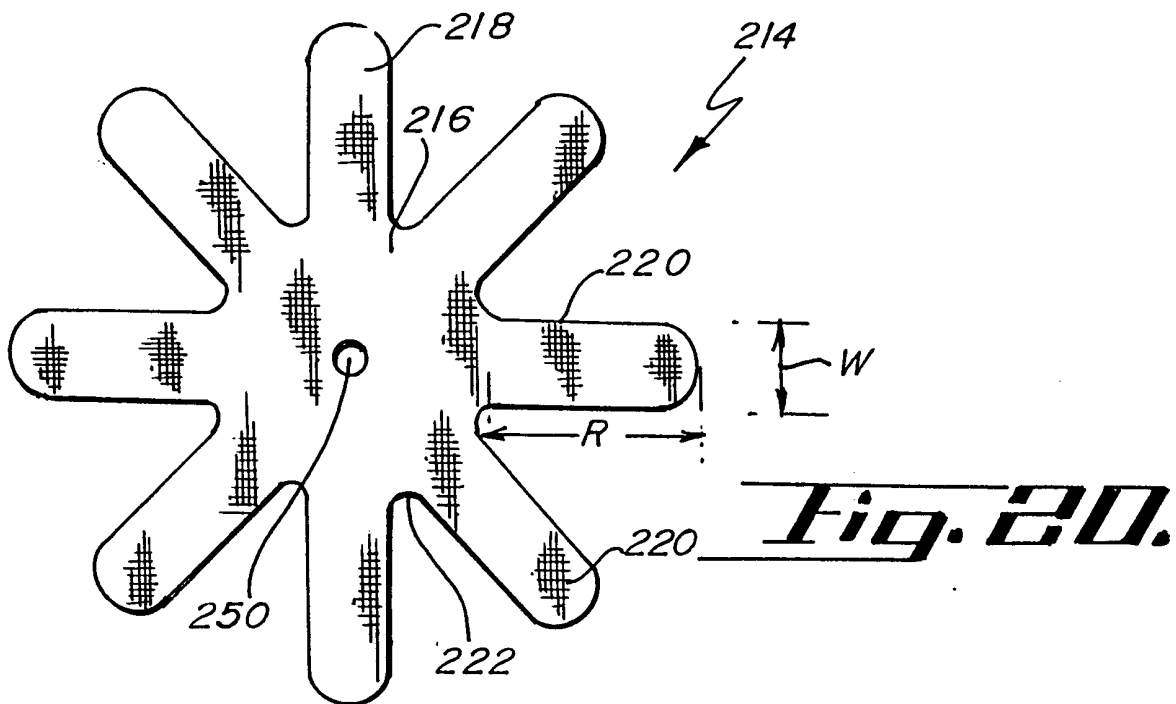
**Fig. 17.**



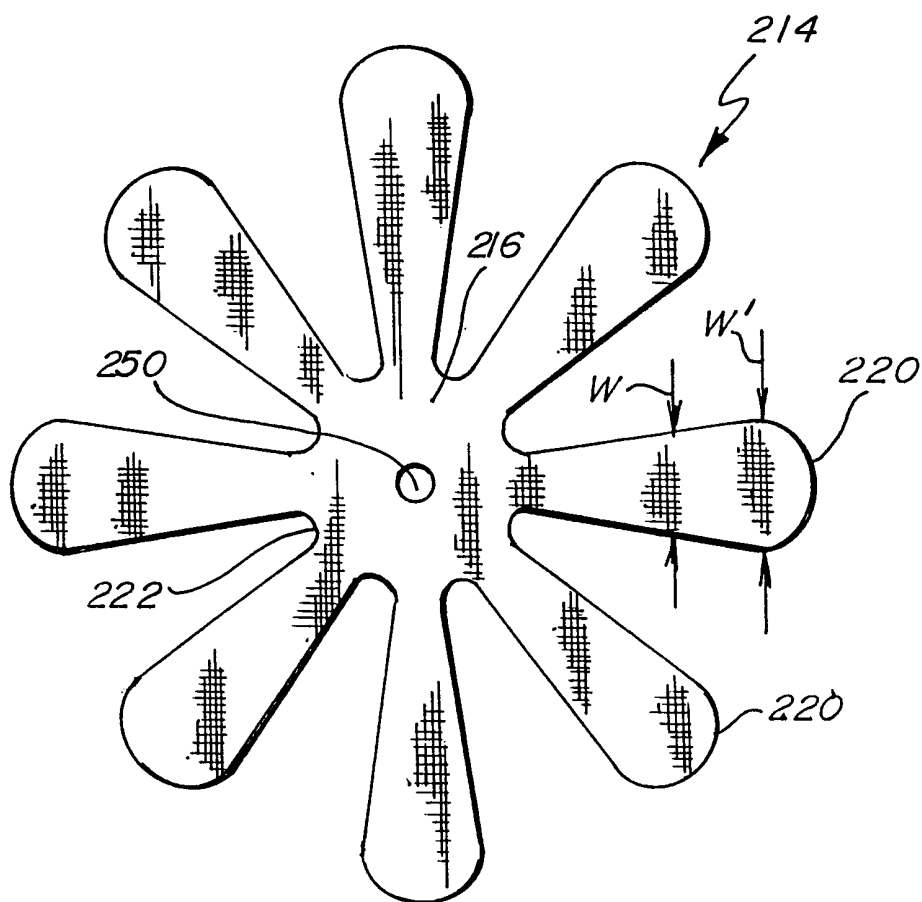
**Fig. 18.**



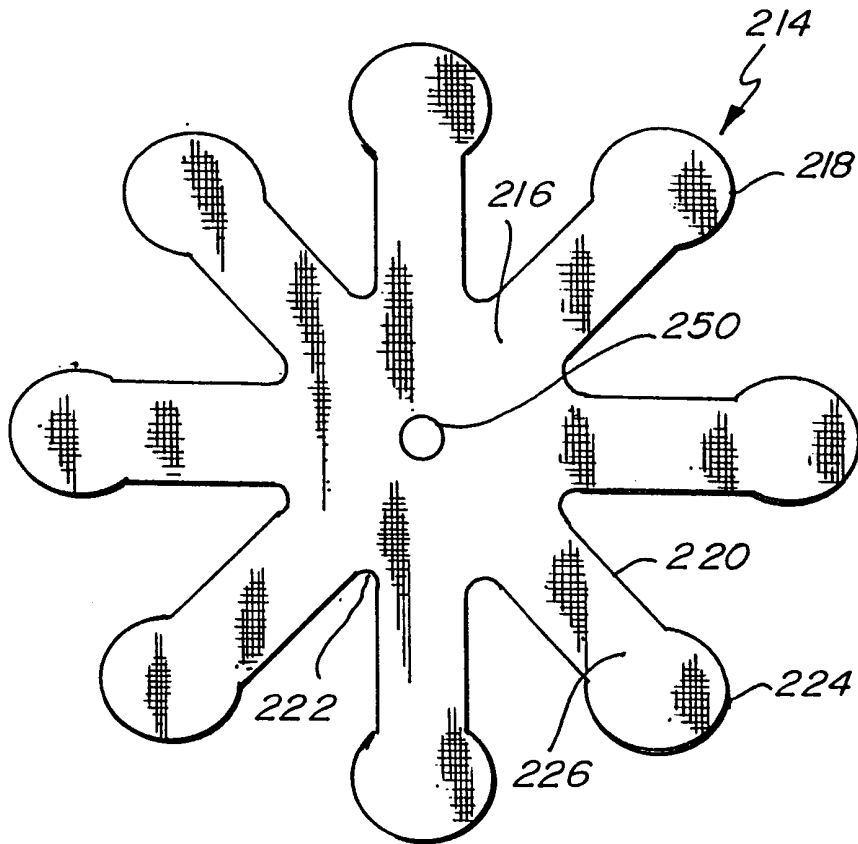
**Fig. 19.**



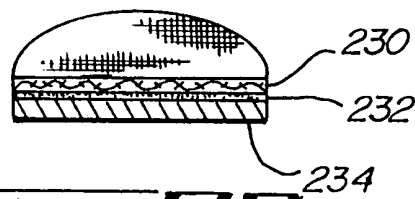
**Fig. 20.**



**Fig. 21.**



*Fig. 22.*



*Fig. 23.*