

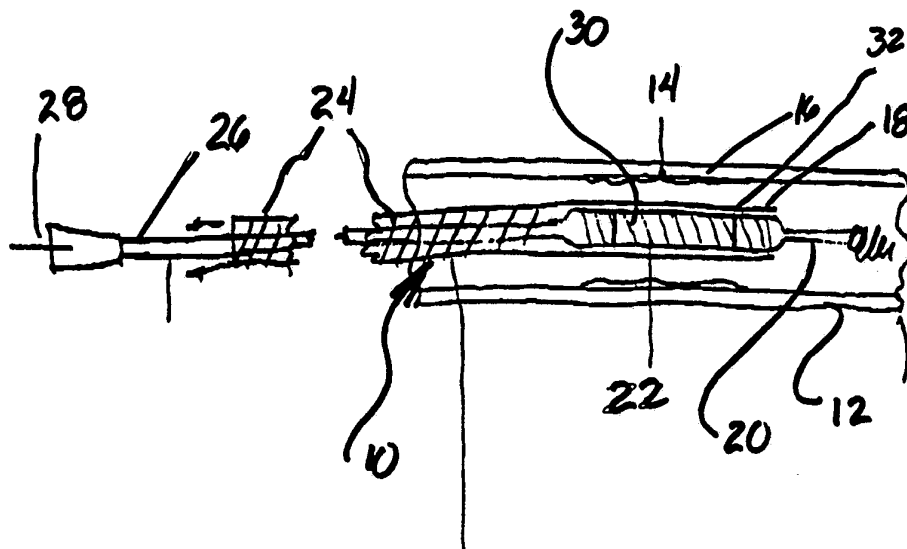

INTERNATIONAL APPLICATION PUBLISHED UNDER THE PATENT COOPERATION TREATY (PCT)

<p>(51) International Patent Classification <sup>5</sup> :  A61N 5/00</p>	<p>A1</p>	<p>(11) International Publication Number: <b>WO 93/04735</b>  (43) International Publication Date: 18 March 1993 (18.03.93)</p>
<p>(21) International Application Number: PCT/US92/07447 (22) International Filing Date: 4 September 1992 (04.09.92)  (30) Priority data: 07/755,480 5 September 1991 (05.09.91) US 07/755,725 6 September 1991 (06.09.91) US  (60) Parent Applications or Grants (63) Related by Continuation US 755,725 (CIP) Filed on 6 September 1991 (06.09.91) US 755,480 (CIP) Filed on 5 September 1991 (05.09.91)  (71) Applicant (for all designated States except US): CEDARS-SINAI MEDICAL CENTER [US/US]; 8700 Beverly Boulevard, Los Angeles, CA 90048 (US).  (71)(72) Applicant and Inventor: HESS, Robert, L. [US/US]; 222 Wyndham Drive, Portola Valley, CA 94025 (US).</p>	<p>(72) Inventors; and (75) Inventors/Applicants (for US only) : SHEFER, Arie [IL/US]; 1673 Malcolm Avenue, Los Angeles, CA 90024 (US). EIGLER, Neal, L. [US/US]; 22154 Alizondo Drive, Woodland Hills, CA 91364 (US). WHITING, James, S. [US/US]; 3318 Mountain View Avenue, Los Angeles, CA 90066-1930 (US).  (74) Agent: PETERSON, James, W.; Burns, Doane, Swecker &amp; Mathis, George Mason Building, Washington and Prince Streets, P.O. Box 1404, Alexandria, VA 22313-1404 (US).  (81) Designated States: AT, AU, BB, BG, BR, CA, CH, CS, DE, DK, ES, FI, GB, HU, JP, KP, KR, LK, LU, MG, MN, MW, NL, NO, PL, RO, RU, SD, SE, US, European patent (AT, BE, CH, DE, DK, ES, FR, GB, GR, IE, IT, LU, MC, NL, SE), OAPI patent (BF, BJ, CF, CG, CI, CM, GA, GN, ML, MR, SN, TD, TG).  Published With international search report.</p>	

(54) Title: METHOD AND APPARATUS FOR RESTENOSIS TREATMENT



(57) Abstract

Method and apparatus (10) for treatment and post-treatment of the stenosed region (14) of an artery (12) after reduction of the region by angioplasty or other means by applying a radioactive dose (30) to said reduced region of the artery by positioning a radioactive dose to the reduced region is disclosed. Low dose, local ionizing irradiation (38) is delivered to the site of an intravascular intervention to prevent and/or minimize excessive cell proliferation. The irradiating source may be located external to the site or may involve a source located within the vessel. The low dose, local ionizing irradiation may also be delivered during the interventional session or thereafter, preferably within 72 hours of the intervention, in a single dose or a fractionated dose, and alone or in combination with at least one radiosensitizing agent.

**FOR THE PURPOSES OF INFORMATION ONLY**

Codes used to identify States party to the PCT on the front pages of pamphlets publishing international applications under the PCT.

AT	Austria	FI	Finland	MN	Mongolia
AU	Australia	FR	France	MR	Mauritania
BB	Barbados	GA	Gabon	MW	Malawi
BE	Belgium	GB	United Kingdom	NL	Netherlands
BF	Burkina Faso	GN	Guinea	NO	Norway
BG	Bulgaria	GR	Greece	NZ	New Zealand
BJ	Benin	HU	Hungary	PL	Poland
BR	Brazil	IE	Ireland	PT	Portugal
CA	Canada	IT	Italy	RO	Romania
CF	Central African Republic	JP	Japan	RU	Russian Federation
CG	Congo	KP	Democratic People's Republic of Korea	SD	Sudan
CH	Switzerland	KR	Republic of Korea	SE	Sweden
CI	Côte d'Ivoire	LI	Liechtenstein	SK	Slovak Republic
CM	Cameroon	LK	Sri Lanka	SN	Senegal
CS	Czechoslovakia	LU	Luxembourg	SU	Soviet Union
CZ	Czech Republic	MC	Monaco	TD	Chad
DE	Germany	MG	Madagascar	TG	Togo
DK	Denmark	ML	Mali	UA	Ukraine
ES	Spain			US	United States of America

METHOD AND APPARATUS FOR RESTENOSIS TREATMENTField of the Invention

This invention relates generally to angioplasty and more particularly to a method and apparatus for preventing restenosis after  
5 angioplasty or other stenosis treatment.

References

The following references are cited in the application as superscript numbers at the relevant portion of the application.

1. Harrison's Principles of Internal Medicine, Ischemic Heart Disease,  
10 Chp. 244, p 1116, Ninth Edition (1980).
2. Ross, R., "Mediators and Modulators of Blood Vessel Growth." Presentation at NHLBI Conference. Vascular Biology and Medicine: The Next Frontier, Bethesda, MD, June 6-7, 1990.
3. Serruys, P.W. et al., "Incidence of Restenosis After Successful  
15 Coronary Angioplasty: A Time-Related Phenomenon. A Quantitative Angiographic Study in 342 Consecutive Patients at 1, 2, 3 and 4 Months." Circulation, 77:361-371 (1988).
4. Dawson, J.T., "Theoretic Considerations Regarding Low-Dose  
20 Radiation Therapy for Prevention of Restenosis After Angioplasty." Texas Heart Institute Journal, 18(1):4-7 (1991).

Background

The most common cause of death in industrial countries is ischemic heart disease<sup>1</sup> which, generally speaking, is an imbalance between myocardial oxygen supply and demand. This imbalance is most often due to  
25 obstruction of large coronary arteries by sclerotic plaque and is related to either

-2-

an absolute decrease in coronary blood flow or an inability to increase coronary blood flow relative to the needs of the heart.<sup>1</sup> Ischemic heart disease is most commonly associated with chest pain, an acute heart attack, an abnormal ventricular rhythm and sudden death. Although various medical and surgical therapies may improve the quality of lifestyle of many patients with this disease, these therapies do not favorably change the underlying cause for the coronary vessel narrowing, nor do they stop its progression.

Various medical interventions have been employed to remove or otherwise treat an offending occlusion in the heart including transluminal angioplasty, coronary artery bypass grafting (CABG), balloon angioplasty, stents and atherectomy.<sup>2</sup> Of these, balloon angioplasty is the procedure of choice and also the least invasive alternative.

In the past, catheters have been developed which may be effectively inserted into blood vessels and maneuvered through a vascular tree. A balloon may be used with such catheters to expand inside the vessel and to open blockages found therein. In a typical percutaneous transluminal coronary angioplasty (PTCA) or percutaneous transluminal angioplasty (PTA) procedure, a guiding catheter is percutaneously introduced into the vascular system of a patient through an artery and advanced therein until the distal tip of the guiding catheter is appropriately positioned. A dilation catheter having a balloon on the distal end thereof and a guide wire are slidably disposed and introduced through the guiding catheter. The guide wire is first advanced through the distal tip of the guiding catheter until the distal end of the guide wire crosses the lesion to be dilated. The dilation catheter is then advanced over the previously introduced guide wire until the dilation balloon on the distal extremity of the dilation catheter is properly positioned inside the lesion. The balloon portion of the dilation catheter is then inflated to a predetermined size to radially compress the atherosclerotic plaque of the lesion against the inside of the artery wall to thereby reduce the annular stenosed area. After a period of time, the balloon is deflated so that blood flow is resumed, allowing the dilation catheter to be removed.

-3-

A major problem encountered in a significant number of patients treated by this procedure is the subsequent narrowing of the artery after the expansion treatment. Various methods and apparatus have been developed to address the restenosis problem including multiple inflations of the balloon during the original procedure, atherectomy, hot balloons, and lasers. Even the installation of permanent stents has been thought to potentially have some value in reducing restenosis rates. See, for example, U.S. Patent No. 5,019,075 to Spears et al. wherein the region surrounding the balloon utilized in the angioplasty procedure is heated by means within the balloon, or within the skin of the balloon, upon inflation of the balloon in order to ideally fuse together fragmented segments of tissue. U.S. Patent No. 4,733,655 to Palmaz discloses an expansible vascular graft which is expanded within a blood vessel by an angioplasty balloon to dilate and expand the lumen of the blood vessel. The Palmaz method and apparatus leaves the expandable vascular graft in place to ideally prevent recurrence of stenosis in the body passageway.

However, recent data seems to indicate that the prior art methods described above do not significantly reduce restenosis rates of occurrence. It would therefore be desirable to have a method and apparatus to treat a lesion in order to reduce the restenosis rate of occurrence. The present invention is believed to provide a unique method and apparatus to reduce the restenosis rate of occurrence following an angioplasty or like-intended procedure.

As discussed above, percutaneous transluminal coronary angioplasty (PTCA) is now commonly used for opening blockages, also called stenoses, of both peripheral and coronary arteries.<sup>2</sup> However, within a period of several months after PTCA, a significant percentage of treated arteries experience a reoccurrence of the narrowing, also called restenosis, and a seriously reduced blood flow. In fact, clinically evident restenosis occurs in 30-40% of cases following successful PTCA and is most frequently observed between 3 and 6 months after the procedure.<sup>3</sup> Late restenosis in the months after angioplasty reduces the initial success rate of 90% to 60-70% after six months. Although the incidence of success and associated complications has

-4-

improved significantly over the last decade, the risk of restenosis has not changed. Hence, of the more than 300,000 coronary arteries subjected to angioplasty during 1990, 30-40% can be expected to restenose.<sup>4</sup> As a result, there is a definite need for a method to reduce this high incidence of restenosis.

5                   As the statistics demonstrate, restenosis after PTCA is a serious problem, and to date, there is no treatment to prevent this complication.<sup>4</sup> It appears to be an inherent reaction of the vessel wall to the angioplasty stretching insult. The outward compression caused by the balloon catheter produces cracking, tearing and stretching of the wall and a subsequent chain  
10 reaction of healing events. In short, it is believed to be caused chiefly by the migration and proliferation of smooth muscle cells which produces an exaggerated healing response. This response can progress to the point of severe restenosis and even occlusion.<sup>4</sup> Due to this restenosis, at least one third of all PTCA patients return for a second and even a third procedure. Accordingly,  
15 there is a definite need to decrease this high incidence of restenosis and thereby increase the long-term benefits of PTCA.

                  Two (2) approaches are currently employed to reduce restenosis. One approach involves the use of a revascularization device, such as the laser catheter, thermal catheter or stent to debulk plaque and create a smooth lumen  
20 to minimize turbulence and platelet aggregation along the vessel wall.

                  Another approach to reduce restenosis involves infusing a drug which modulates cell growth into the target artery before, during or after the angioplasty to inhibit the proliferation of smooth muscle cells.<sup>4</sup> In particular, antiplatelet agents such as aspirin and dipyridamole, and anticoagulants such as  
25 heparin, have inhibited platelet aggregation and thrombus formation to a limited degree, thereby reducing the risk of early occlusion. There is therefore a critical need for an effective method to prevent and/or minimize restenosis after an intravascular procedure. The present invention satisfies this need and provides related advantages as well.

### Summary of the Invention

The purpose of the invention is to provide method and apparatus to significantly reduce restenosis rates of occurrence following an angioplasty procedure. To accomplish this purpose, there is provided method and apparatus for exposing the dilated lesion to a radiation dose that will affect smooth muscle cell growth. There is provided a catheter which has at its distal end a radioactive source, the source being maneuverable to the site of a lesion which has been dilated or removed, the apparatus allowing the site to be exposed to the radiation dose that will affect smooth muscle cells such that the rapid growth of such cells can be prevented, thereby controlling restenosis.

In one aspect of the invention there is provided a method for treatment and post-treatment of the stenosed region of an artery comprising the steps of:

reducing the annular stenosed area within an artery; and  
applying a radioactive dose to the area of reduced stenosis.

In another aspect of the invention there is provided a method for treatment and post-treatment of the stenosed region of an artery after reduction of said region by angioplasty or other means comprising the step of applying a radioactive dose to said reduced region of the artery.

In yet another aspect of the invention there is provided apparatus for post-treatment of a stenosed region of an artery that has been reduced by angioplasty or other means comprising:

radioactive dose means; and  
positioning means operatively connected to said dose means to position said dose means within the stenosed region of an artery that has been reduced by angioplasty or other means.

Applicants have discovered that the local application of low dose ionizing radiation such as gamma radiation, x-rays, beta radiation, alpha radiation, proton and neutron radiation following balloon angioplasty can control the overhealing process responsible for late restenosis. Hence, the

-6-

present invention describes a method for preventing restenosis after any interventional procedure, including but not limited to balloon and laser angioplasty, stents and atherectomy. Low dose, local irradiation is delivered to the site of intervention to prevent and/or minimize excessive cell proliferation.

5 The irradiating source may be located external to the site, or may be permanently or removably located within the subject vessel. The low dose local irradiation may also be delivered alone or in combination with radiosensitizing agents that enhance the tissue reaction to radiation. In addition, the irradiation may be delivered during the angioplasty session, during the same  
10 hospitalization, or at some later time.

A further aspect of the invention therefore involves a method for the local delivery of low dose external irradiation to a vessel wall following angioplasty. During cineangiography in the posterior orientation, when the balloon is in position for angioplasty, an ink mark, tattoo or the like is placed  
15 on the subject's chest to indicate the place where to administer external irradiation. This mark or the like is then used to position the external radiation port, which usually measures 4 square centimeters. However, the port can be widened or narrowed using appropriate shielding, depending upon the size of the lesion, to circumscribe the area to be irradiated. The marked area is then  
20 irradiated in a single dose or in a fractionated dose from an external source. The irradiation can be combined with the interventional procedure in the same session, or at some later time, preferably within 72 hours after the procedure. The irradiation may also be combined with radiosensitizers, such as bromodioxyuridine and the like. These agents may be administered  
25 systemically (e.g., administered by the oral, injectable or rectal route), or locally, through a perforated balloon catheter introduced percutaneously. The radiosensitizers enhance the tissue reaction to radiation, thereby reducing the radiation dose required without diminishing the radiation effect. The recommended dosage range of dibromodioxyuridine is between 20-500 mg  
30 administered subcutaneously.



-7-

Still another aspect of the invention involves a method for the local delivery of low dose intravascular irradiation by a removable or non-removable source after an interventional procedure. A radioactive iridium wire or the like is inserted directly through a catheter and positioned precisely at the target site during the procedure. The target is then irradiated in a single dose. As above, the irradiation may also be combined with at least one radiosensitizer.

It is to be understood, however, that other aspects may be utilized and that changes may be made without departing from the scope of the invention. The following detailed description is, therefore, not to be taken in a limiting sense, and the scope of the present invention is best defined by the appended claims.

Accordingly, it is a general object of the present invention to control or modulate cell proliferation following injury.

It is still another object of the present invention to provide a method to decrease the presently high incidence of late restenosis occurring after an interventional procedure.

It is another object of the present invention to provide a method to maintain the long-term benefits of PTCA.

These and other objects will become readily apparent to those skilled in the art from the following detailed description and appended claims.

#### Description of the Drawing

The present invention will be described in connection with the accompanying drawing in which:

FIG. 1 is a partial cross-sectional view of an embodiment of the invention wherein said dose applying means is a radioactive element contained within a wire wound housing for radioactive containment, the housing having a window cut-out. A larger wire wound sheath covers the window during

insertion and removal, the sheath being withdrawn to expose the radioactive element at the lesion site.

FIG. 2 is a partial perspective view of an alternate embodiment having a radioactive dose means positioned upon the balloon of an expandable balloon catheter, said balloon catheter being provided with a means or perfusion to allow blood flow during the time the balloon is inflated.

FIG. 3 is an enlarged partial cross-sectional view of a portion of the apparatus shown in FIG. 2.

FIG. 4 is a partial perspective view of the apparatus shown in FIGS. 2 and 3 upon expansion of the balloon portion of the apparatus.

FIG. 5 is a partial perspective view of another embodiment of the invention wherein the radioactive dose means is an element that may be contained within a complementary containment means provided with a remotely actuated window.

FIG. 6 is a partial perspective cross-sectional view of a catheter tip containing radioactive dose means showing the remotely actuated window.

FIG. 7 is a partial perspective cross-sectional view of an alternate embodiment further including a stent wherein said radioactive dose means is in the form of a coating of radioactive material on the stent.

FIG. 8 is a partial cross-sectional view of the device shown in FIG. 7 after expansion of the stent shown in FIG. 7.

FIG. 9 is a partial perspective view of the stent illustrated in FIGS. 7 and 8 wherein the stent is implanted within the artery.

FIG. 10 is a photomicrograph of a normal central ear artery from a New Zealand white rabbit following formalin fixation and hematoxylin-eosin staining.

FIG. 11 is a photomicrograph of a dilated central ear artery from a New Zealand white rabbit fed a cholesterol rich diet. The central ear artery had been fixed in formalin and stained with hematoxylin-eosin.

FIG. 12 is a photomicrograph of the central ear artery from a New Zealand white rabbit following balloon dilatation without irradiation. The

central ear artery had been fixed in formalin and stained with hematoxylin--  
eosin.

FIG. 13 is another photomicrograph of the central ear artery  
from a New Zealand white rabbit following balloon dilatation without  
5 irradiation. The central ear artery had been fixed in formalin and stained with  
hematoxylin-eosin.

FIG. 14 is a photomicrograph of the central ear artery from a  
New Zealand white rabbit irradiated immediately following balloon dilatation.  
As above, the central ear artery had been fixed in formalin and stained with  
10 hematoxylin-eosin.

FIG. 15 is a photomicrograph of the central ear artery from a  
New Zealand white rabbit irradiated one (1) day after balloon dilatation. The  
central ear artery had been fixed in formalin and stained with hematoxylin--  
eosin.

FIG. 16 is a photomicrograph of the central ear artery from a  
15 New Zealand white rabbit irradiated two (2) days after balloon dilatation. The  
central ear artery had been fixed in formalin and stained with hematoxylin--  
eosin.

FIGS. 17A-C show a further aspect of the invention wherein the  
20 dose applying means includes radioactive seeds encapsulated in a heat  
shrinkable polymer catheter tip. FIG. 17A shows a catheter shaft and  
polymeric tubing; FIG. 17B shows a plurality of radioactive seeds which are  
separated by meltable material; and FIG. 17C shows the tubing after heat  
shrinking.

25

#### Description of the Preferred Embodiments

With continued reference to the drawing, FIG. 1 illustrates the  
apparatus and method for preventing restenosis of an artery that has been  
enlarged by angioplasty or other procedure. Specifically, apparatus, shown  
generally at 10, is positioned within artery segment 12 having lesion site 14

-10-

which has previously been enlarged by angioplasty or other procedure such that atherosclerotic plaque 16 has been radially compressed by expansion of the balloon portion of an angioplasty device (not shown) or removed by other means. Device 10 having distal end 18 with tip 20 and wire wound housing 22 is positioned such that housing 22 is positioned within the lesion site 14. Housing 22 contains radioactive dose means 30 and is provided with window cut-out 32. Device 10 includes a wire wound retractable sheath 24 and catheter shaft 26 with guide wire and guide wire port 28. A radioactive dose means 30 is moveable by advancing or retracting catheter shaft 26 which may be referred to as a positioning means. Sheath 24 is drawn back when the radioactive dose means is positioned directly proximate the lesion site 14 such that window cut-out 32 is opened to expose the lesion site 14, which has been previously dilated, to a radiation dose that will affect the smooth muscle cells/plaque.

In FIG. 2 there is illustrated a device shown generally at 34 which is an alternate embodiment of the invention further including an angioplasty balloon 36 with dose means in the form of radioactive elements 38 attached thereto. Device 34 includes catheter shaft 40 having perfusion capabilities provided by holes 41 positioned proximately and distally to the balloon portion.

FIG. 3 shows in expanded view details of balloon 36 of FIG. 2 positioned about catheter shaft 40 having two main lumens 42 and 44. Lumen 42 makes provision for guide wire capability and contains perfusion holes. Lumen 44 is the lumen which provides the passage to inflate the balloon from the inflation port 45 shown in FIG. 2 at the proximal end of the device 34. The radioactive elements 38 are not shown in FIG. 3.

FIG. 4 illustrates the device 34 of FIGS. 2 and 3 wherein the balloon 36 is expanded in the vicinity of the lesion site 46, and the radioactive elements 38 are forced into contact with the lesion.

It is understood that the various embodiments of the subject invention are useful in the treatment of a lesion site within an artery. The term "lesion site" as used herein includes those lesions which have been treated with

balloon angioplasty, those lesions that have been treated by an atherectomy or laser angioplasty, those lesions that have been treated by rotational atherectomy or any other means of compressing or removing the material of the lesion which may cause trauma to the artery. It is this trauma which causes the proliferation of smooth muscle cells which method and apparatus of the subject invention is intended to inhibit.

With regard to all embodiments of the subject invention, the term "radioactive dose" means bombardment by particles emitted from radioactive materials including, but not limited to, materials such as Radon 222, Gold 198, Strontium 90, Radium 192, and Iodine 125. These materials may be incorporated into or delivered in a solid, liquid, or gaseous form, and the delivery of such forms is considered to be within the scope of the subject invention.

FIG. 5 illustrates an alternate embodiment of the subject invention in the form of apparatus shown generally at 48. Sheath 50 of said device is preferably made from a helically wound wire member to provide a measure of shielding for the radioactive dose means. Device 48 includes positioning means 52 which is a motion wire providing slidable motion of the radioactive dose means 54 within the sheath. Radioactive dose means 54 is thus positionable proximate to the lesion site 56 of artery segment 58 and retractable within sheath 50 for insertion and removal within the artery segment 58.

FIG. 6 illustrates yet another embodiment of the subject invention in the form of the device shown generally at 60, similar to the device 10 shown in FIG. 1. In FIG. 6, device 60 is comprised of the shaft portion 62 and contains at its distal end a canister 64 containing the radioactive dose means. This canister 64 has a remotely actuated window 66 which can be actuated through port 68 to expose the radioactive dose means to the lesion 70.

FIGS. 7, 8, and 9 illustrate yet another embodiment of the subject invention wherein a device shown generally at 72 is an inflatable stent delivery balloon system for delivery and expansion of stent 74. Stent 74 may

-12-

be removable or may be a permanent implant. In the case of a permanently implanted stent, the radioactive dose means has to be carefully chosen in terms of dose level and half-life in order to limit the total radiation dose. In this embodiment, the radioactive dose means is associated with stent 74 and may be included as a cladding, a coating, an additive within the basic stent material itself, or an attachment by other means to the stent. In FIG. 7 the device 72 includes an inflatable balloon dilation catheter to position stent 74 within lesion 76.

FIG. 8 shows the expanded balloon of the stent delivery system 78 having dilated stent 74 in close proximal contact with lesion 76.

FIG. 9 shows the stent 74 in place within lesion 76 with the stent delivery system having been removed from the artery.

The foregoing description of the drawing illustrates various methods of the invention. It should be understood that the methods of the invention include the treatment and post-treatment of an annularly stenosed region of an artery. Most methods of treatment currently available cause some trauma to the artery. The artery in response to this trauma proliferates the growth of smooth muscle cells in many cases, and this results in restenosis at the site of the original stenosis -- usually within a six-month period. The post-treatment therefore consists of exposing the treated region of the stenosis to a radiation dose which is sufficient to retard or halt the proliferation of smooth muscle cells. It should also be pointed out that both the treatment and post-treatment could occur simultaneously if the device which removes or compresses the stenosis material also contains the radioactive dose means.

A novel experimental model was developed to directly study the effects of balloon dilatation injury with and without local irradiation. This model involved the use of a balloon catheter to produce a single injury in the central ear artery of New Zealand white rabbits. The protocol which follows, however, is provided only to illustrate the principles of the invention; it is not intended to limit the invention, which extends to the full scope of the appended claims.

-13-

Example 1Animal Model

Fifty (50) adult male New Zealand white rabbits, initially weighing 3.5 kilograms, were purchased from a commercial vendor. The rabbits were noted to be healthy upon arrival and during the entire study. All rabbits were fed standard chow (Purina Rabbit Chow-Complete; Purina Mills, Inc., St. Louis, Missouri), 10 grams per pound of body weight per day and water ad libitum. Three (3) rabbits were fed a high cholesterol diet by adding 10% peanut oil and 2% cholesterol to the standard chow. The rabbits were quarantined for five days to facilitate acclimation to their surroundings. During that time the rabbits were also anesthetized for conditioning with ketamine 35 milligrams per kilogram and xylazine 5 milligrams per kilogram (mg/kg) by an intramuscular injection (IM). The rabbits were then tattooed in the left ear for identification, and treated with 0.1 milliliter of 1% ivermectin by IM injection for the prevention and prophylaxis of parasites. The animals were fasted for 12 hours prior to the procedure; however, water was not withheld.

Experimental Design

Thirty-six (36) of the fifty (50) rabbits were divided into six (6) groups of six (6) rabbits as follows:

- 20            Group A -    Irradiation was applied immediately after the balloon dilatation.
- Group B -    Irradiation was applied one (1) day after the balloon dilatation.
- Group C -    Irradiation was applied two (2) days after the balloon dilatation.
- 25            Group D -    Irradiation was applied three (3) days after the balloon dilatation.
- Group E -    Irradiation was applied (3) days after the balloon dilatation, but only to the right ear.

-14-

Group F - Irradiation was applied seven (7) days after the balloon dilatation.

#### Surgical Procedure

5 The rabbits were placed in a restraining cage to allow placement of a butterfly needle in the marginal ear vein. Anesthesia was induced with a slow intravenous (IV) solution of ketamine 10 mg/ml and xylazine 2 mg/ml to effect. Following induction, the depth of anesthesia was monitored by the loss of the righting reflex and jaw tension and controlled with an intermittent IV infusion of the ketamine-xylazine solution.

10 The dorsal side of both ears was shaved and prepped with a 10% betadine solution. The rabbit was placed under a 250 watt heat lamp to induce vasodilation. After superficial mechanical stimulation, the central artery of the ear was entered with a 22 gauge over-the-needle catheter (Angiocath, Deseret Medical, Inc., Sandy, Utah). The heat lamp was turned off immediately after achieving vascular access to avoid heat stroke. An IV injection of Heparin 200 units/kg was administered, and a DGW 1.5 millimeter angioplasty balloon catheter (SciMed, Minneapolis, Minnesota) was then advanced into the artery under direct inspection. The catheter was placed and inflated to 6 atmospheres of pressure for ten (10) minutes in the thirty-six (36) rabbits divided into groups  
15 A-F above. Applicants had also experimented with a one (1) minute inflation time at 6 atmospheres of pressure to induce injury. However, the one (1) minute inflation time was discarded due to suboptimal injury.

25 While the balloon was inflated and the animal still anesthetized, the skin over the edges of the dilated arterial segment was tattooed to mark the location of the balloon dilatation. At the end of the procedure, a dressing was applied to the arterial puncture site for fifteen (15) minutes and then removed. The rabbits recovered from the anesthesia and were followed in the vivarium for three (3) weeks.



-15-

After three (3) weeks, the rabbits were again anesthetized, and the ears were prepared in the same manner for vascular access. Both ears were then entered with a 21 gauge butterfly needle.

5 The rabbits were euthanized with pentobarbital sodium 300 mg IV, and the ear arteries perfused with 10% buffered formalin for ten (10) minutes under a pressure of 100 millimeters Hg. A full thickness central segment of the ear, containing the central artery and vein and the surrounding tissues, was excised for histological examination.

#### Irradiation System

10 The dilated segment of the rabbit central ear artery was irradiated by a beta irradiation source commonly used to treat ocular pterygium. This irradiation source is a flat sealed Strontium - 90 disc, 8.5 mm in diameter, with a dose-rate of 50 Rads per second in contact mode (Amershon Corp., Arlington Heights, Illinois). The disc is mounted on an applicator shaped handle with a  
15 protective plastic shield on the shaft. The source was passed over the artery for 60 seconds in order to deliver a skin dose of 900 Rads of radiation.

#### Histological Examination

Each arterial specimen was divided into four sections: two normal sections, proximal and distal to the dilated segment (a, d), and two  
20 sections within the dilated segment (b, c). The sections were stained with hematoxylin-eosin for light microscopy. For each section, 4-6 representative cross-sections were mounted on a slide and projected into a rear projection screen with a magnification of 150. The edges of the lumen, intima and media were traced manually with an electromagnetic pointer and acquired into a  
25 personal computer for area calculation and further analysis.

#### Measurements

The intima to media area ratio (IMR) measurement was used to compare treatment groups. This area ratio was used instead of absolute values

-16-

in order to compensate for differences in diameter among the various specimens due either to variation in animal size or variation in vascular distention and pressure during the fixation in vivo.

### Statistical Analysis

5           The differences between the groups were analyzed with the student t-test. The differences between the normal and the dilated segments in each artery were analyzed with the paired t-test.

### Results

10           This novel experimental model provides a simple, rapid and reproducible method for arterial wall injury. The entire procedure is carried out in a superficial artery, the rabbit central ear artery, using a percutaneous technique. The turn around time, including animal preparation and the induction of anesthesia, is approximately 45 minutes. Hence, twelve rabbits can be treated in one (1) day. In addition, because the entire procedure is  
15 performed in the rabbit ear, which is essentially transparent, the use of a fluoroscopic system is obviated.

          The IMR in the normal, non-dilated, non-irradiated segments, was  $0.048 \pm 0.14$  ( $p < 0.002$ ) as illustrated in FIG. 10. In normal arteries dilated for a period of one minute, without irradiation, the IMR for the dilated  
20 segment was  $0.14 \pm 0.3$ , which was not statistically different from the non-dilated segments. However, as illustrated in FIGS. 12 and 13, there was significant intimal proliferation in all arteries dilated for a period of 10 minutes, with an IMR of  $0.28 \pm 0.14$ . As a result, the ten (10) minute dilatation period was used to induce injury and subsequent intimal proliferation to study the  
25 effect of localized irradiation on restenosis. Also note that in the three (3) rabbits fed with a cholesterol rich diet, there was additional massive foam cell accumulation and aggressive intimal proliferation following dilatation. The IMR in these arteries was  $0.61 \pm 0.29$ , and is illustrated in FIG. 11.

Hence, to summarize the results recited above, the IMR was  $0.048 \pm 0.3$  in normal segments and  $0.18 \pm 0.3$  in the dilated segments ( $p < 0.1$ ). In the normal diet group, the IMR was  $0.14 \pm 0.03$  after one (1) minute of inflation and  $0.28 \pm 0.14$  after ten (10) minutes of inflation ( $p < 0.002$ ).

5 In addition, the IMR in normal arteries treated with irradiation was  $0.054 \pm 0.11$ , which is not statistically different from non-irradiated normal arteries. It was also found, however, that the IMR in dilated, irradiated arteries was not statistically different from normal, undilated non-irradiated arteries. In fact, applicants discovered that the IMR in dilated, irradiated  
 10 arteries was dependent upon the time interval between the arterial injury and the irradiation treatment, as illustrated in Table I below and FIGS. 14, 15 and 16.

TABLE I

	<u>Time Delay</u>	<u>IMR</u>
	0	$0.11 \pm 0.12$
15	1 day	$0.09 \pm 0.10$
	2 days	$0.085 \pm 0.13$
	3 days	$0.09 \pm 0.11$
	7 days	$0.21 \pm 0.17$

Table I demonstrates that the difference between each of the irradiated groups  
 20 and the non-irradiated group (IMR,  $0.28 \pm 0.14$ ) was statistically significant. However, of even more significance was the discovery that the optimal timing for the irradiation treatment was between one (1) and three (3) days after the balloon dilatation. Hence, these studies demonstrate the usefulness of this experimental model and the efficacy and optimal timing of local irradiation  
 25 following balloon angioplasty to minimize and even prevent restenosis.

Example 2

The animal model, experimental design, surgical procedure, histological examination, measurements and statistical analysis are to be used as

-18-

described above. In addition, however, at least one (1) radiosensitizer can be administered in combination with the irradiation to reduce the administered radiation dose without diminishing the radiation effect. One skilled in the art will recognize many radiosensitizing agents for application here; however, bromodioxymurine can be administered systemically or locally in a dose ranging between 2-10 mg/kg of body weight in combination with irradiation for the prevention of restenosis after angioplasty. When a radiosensitizer such as bromodioxymurine is administered, the irradiation dose may be reduced by 40-60%. This reduction in irradiation dose increases the margin of safety for this particular treatment. In particular, it maintains a constant effect on the target tissue, but spares surrounding tissue from incidental injury.

According to a further aspect of the invention, the dose means comprises a heat shrinkable polymer catheter tip containing radioactive seeds/particles, as shown in FIGS. 17A-C. As shown in FIG. 17A, an expanded heat shrinkable polymeric tubing 79 is attached to a catheter shaft 80. As shown in FIG. 17B, a plurality of radioactive seeds 81 is located in tubing 79. The number and type of radioactive seeds 81 is selected to correspond to the length of the stenosis to be irradiated and the dose desired. The seeds 81 may be separated by spacers 82, and the spacers 82 may be of a meltable material such as plastic to provide encapsulation. An end plug 83, which may also be meltable, may be provided. Upon heating, the heat shrinkable polymeric tubing 79 encapsulates the seeds 81 and becomes smaller in diameter at each of the spaces 82, as shown in FIG. 17C. Thus, the construction shown in FIG. 17C imparts articulation and flexibility to the catheter tip. This embodiment lends itself particularly well to remote automated assembly of the unit.

Having indicated above preferred embodiments of the present invention, it will occur to those skilled in the art that modification and alternatives can be practiced within the spirit of the invention. It is accordingly intended to define the scope of the invention only as indicated in the following claims.

What Is Claimed Is:

1. A method for treatment and post-treatment of the stenosed region of an artery comprising the steps of:  
reducing the annular stenosed area within an artery; and  
5 applying a radioactive dose to the area of reduced stenosis.
2. A method as defined in Claim 1 wherein the step of applying the radioactive dose is sufficient to affect smooth muscle cells within the area of reduced stenosis to inhibit rapid growth of such cells, thereby preventing restenosis of the artery.
- 10 3. A method as defined in Claim 1 further including the step of continuing to reduce the annular stenosed area while applying a radioactive dose to said area.
4. A method as defined in Claim 1 including the step of allowing blood flow through the area of reduced stenosis while applying the  
15 radioactive dose.
5. A method as defined in Claim 1 including the contacting of the tissue of the area of reduced stenosis with a radioactive material.
6. A method as defined in Claim 1 further including the step of containing a source of radioactive dose before and after exposure to said area  
20 of reduced stenosis.
7. A method for treatment and post-treatment of the stenosed region of an artery after reduction of said region by angioplasty or other means comprising the step of applying a radioactive dose to said reduced region of the artery.

-20-

8. A method as defined in Claim 1 wherein the step of applying the radioactive dose is sufficient to affect smooth muscle cells within the area of reduced stenosis, thereby inhibiting rapid growth of such cells and preventing restenosis of the artery.

5 9. Apparatus for post-treatment of a stenosed region of an artery that has been reduced by angioplasty or other means comprising:  
radioactive dose means; and  
positioning means operatively connected to said dose means to  
position said dose means within the stenosed region of an artery that has been  
10 reduced by angioplasty or other means.

10. Apparatus as in Claim 9 wherein the positioning means includes a retractable sheath which may be removably positioned over said radioactive dose means.

11. Apparatus as in Claim 9 wherein the positioning means  
15 further includes an angioplasty balloon and said radioactive dose means is connected to said balloon and is positioned in the stenosed region by expansion of said balloon.

12. Apparatus as in Claim 9 wherein the positioning means includes a stent and said radioactive dose means is associated with said stent.

20 13. A method for the treatment of excessive cell proliferation after an intravascular interventional procedure which comprises administering to a host an effective amount of radiation localized to the site of said procedure to modulate cell proliferation.

25 14. The method according to Claim 13 wherein said radiation is administered by an external radiation source.

-21-

15. The method according to Claim 14 wherein said external radiation is administered in a single dose or in a fractionated dose.
16. The method according to Claim 14 wherein said external radiation is administered in an amount from at least 150 to 900 Rads.
- 5 17. The method according to Claim 14 wherein said radiation is administered to a localized field circumscribing the site of said procedure.
18. The method according to Claim 13 wherein said radiation is administered at a time during said procedure.
- 10 19. The method according to Claim 13 wherein said radiation is administered at a time after said procedure.
20. The method according to Claim 13 wherein said radiation is administered within seventy-two (72) hours of said procedure.
21. The method according to Claim 13 wherein said radiation is administered by an intravascular radiation source.
- 15 22. The method according to Claim 21 wherein said intravascular radiation source is removable.
23. The method according to Claim 21 wherein said intravascular radiation source is permanently implanted.
- 20 24. The method according to Claim 13 wherein said radiation is administered in combination with an effective amount of at least one radiosensitizing agent.

-22-

25. The method according to Claim 24 wherein said agent is bromodioxyuridine.

26. The method according to Claim 25 wherein bromodioxyuridine is administered in a dose from about 2-10 mg/kg of body weight.

27. The method according to Claim 24 wherein said agent is administered systemically.

28. The method according to Claim 24 wherein said agent is administered by the oral, injectable or rectal route.

29. The method according to Claim 24 wherein said agent is administered locally.

30. The method according to Claim 24 wherein said agent is administered percutaneously through a perforated balloon catheter.

31. A method for prevention of restenosis after angioplasty which comprises administering to a host in a single or fractionated dose, within 72 hours of said angioplasty, from about 150 to 900 Rads of ionizing radiation localized to the site of said angioplasty to modulate cell growth.

32. The method according to Claim 31 wherein said radiation is administered by an external source.

33. The method according to Claim 31 wherein said radiation is administered by an intravascular source.



-23-

34. The method according to Claim 31 wherein said radiation is administered in combination with at least one radiosensitizing agent.

35. The method according to Claim 34 wherein said radiosensitizing agent is bromodioxyuridine.

5 36. The method according to Claim 35 wherein bromodioxyuridine is administered locally or systemically in a dose from about 2-10 mg/kg of body weight.

37. The method according to Claim 31 wherein said radiation is reduced from about 40-60% when administered in combination with at least  
10 one radiosensitizing agent.

38. A method for prevention of restenosis in a host after angioplasty which comprises the steps of:

- 15 a) marking the site of said angioplasty for the local administration of ionizing radiation; and  
b) administering an effective amount of said radiation to inhibit excessive cell proliferation.

39. The method according to Claim 38 wherein said radiation is administered in combination with an effective amount of at least one radiosensitizing agent.

20 40. A method for prevention of restenosis in a host after angioplasty which comprises the steps of:

- a) marking the site of said angioplasty for the local administration of radiation;

-24-

- b) administering a radiation dose from about 150-900 Rads by an external radiation source within 72 hours of said angioplasty to inhibit excessive cell proliferation.

5 41. A method for prevention of restenosis in a host after angioplasty which comprises the steps of:

- a) marking the site of said angioplasty for the local administration of ionizing radiation;
- b) administering an effective amount of at least one radiosensitizing agent, such as bromodioxuridine, in a dose from about 2-10 mg/kg of body weight, locally or systemically; and
- c) administering to the site of said angioplasty, 40-60% of from about 150-900 Rads of radiation, within 72 hours of said angioplasty to inhibit excessive cell proliferation.

15 42. A method for prevention of restenosis in a host after angioplasty which comprises the steps of:

- a) marking the site of said angioplasty for the local administration of radiation;
- b) introducing an intravascular radiation source proximal to the site of said angioplasty; and
- c) administering to the site an effective amount of radiation to inhibit excessive cell proliferation.

20 43. The method according to Claim 42 wherein said radiation is administered in combination with an effective amount of at least one radiosensitizing agent.

25 44. A method for prevention of restenosis in a host after angioplasty which comprises the steps of:

-25-

- 5
- 10
- a) marking the site of said angioplasty for the local administration of radiation;
  - b) introducing an intravascular radiation source proximal to the site of said angioplasty;
  - c) administering an effective amount of at least one radiosensitizing agent, such as bromodioxuridine, in a dose from about 2-10 mg/kg of body weight, locally or systemically; and
  - d) administering to the site of said angioplasty 40-60% of from about 150-900 Rads of radiation, within 72 hours of said angioplasty to inhibit excessive cell proliferation.

15

45. A method for treatment and post-treatment of the stenosed region of an artery comprising the steps of:

- reducing the annular stenosed area within an artery; and
- applying a radioactive dose to the area of reduced stenosis by positioning dose means within the artery and adjacent the area of reduced stenosis, the dose means including a plurality of radioactive seeds.

20

46. A method as defined in Claim 45, wherein the dose means comprises a tip of a catheter wherein the radioactive seeds are spaced apart and located within a heat shrunk polymeric tubing.

25

47. Apparatus for post-treatment of a stenosed region of an artery that has been reduced by angioplasty or other means comprising:

- radioactive dose means comprising a plurality of spaced-apart radioactive seeds supported within a polymeric tube; and
- positioning means operatively connected to said dose means to position said dose means within the stenosed region of an artery that has been reduced by angioplasty or other means.

-26-

48. Apparatus as in Claim 47 wherein the tube includes areas of reduced diameter between each of the radioactive seeds.

49. Apparatus as in Claim 47 wherein the tube comprises a heat shrunk tube and the radioactive seeds are encapsulated in the heat shrunk  
5 tube.

50. Apparatus as in Claim 47 wherein a distal end of the tube is sealed and the radioactive seeds are separated from each other by non-radioactive material.

51. Apparatus as in Claim 50 wherein the non-radioactive  
10 material comprises melted plastic material which forms spacers between the radioactive seeds.

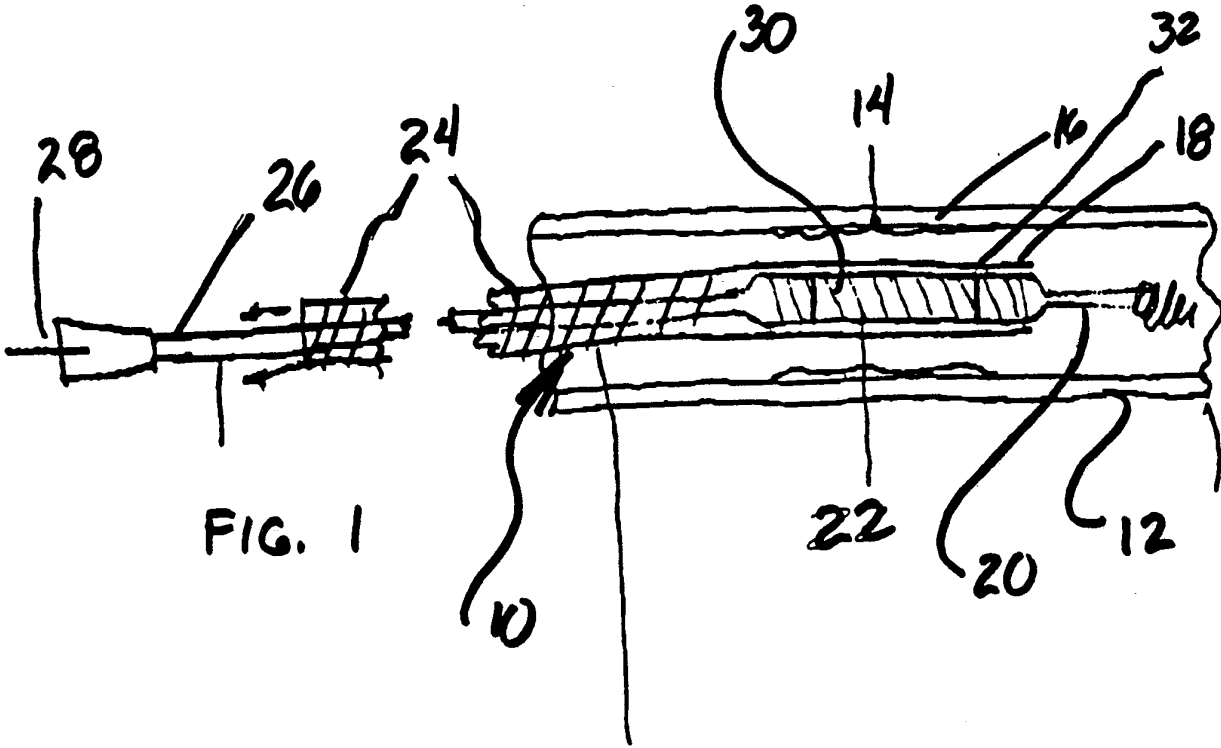

FIG. 1

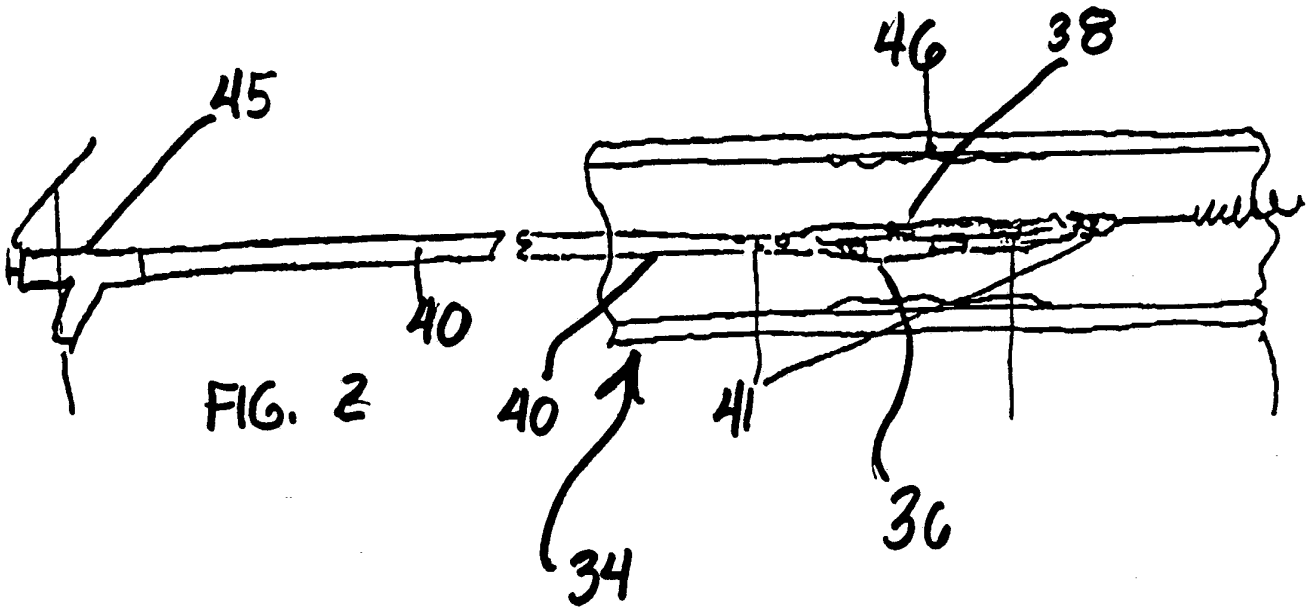
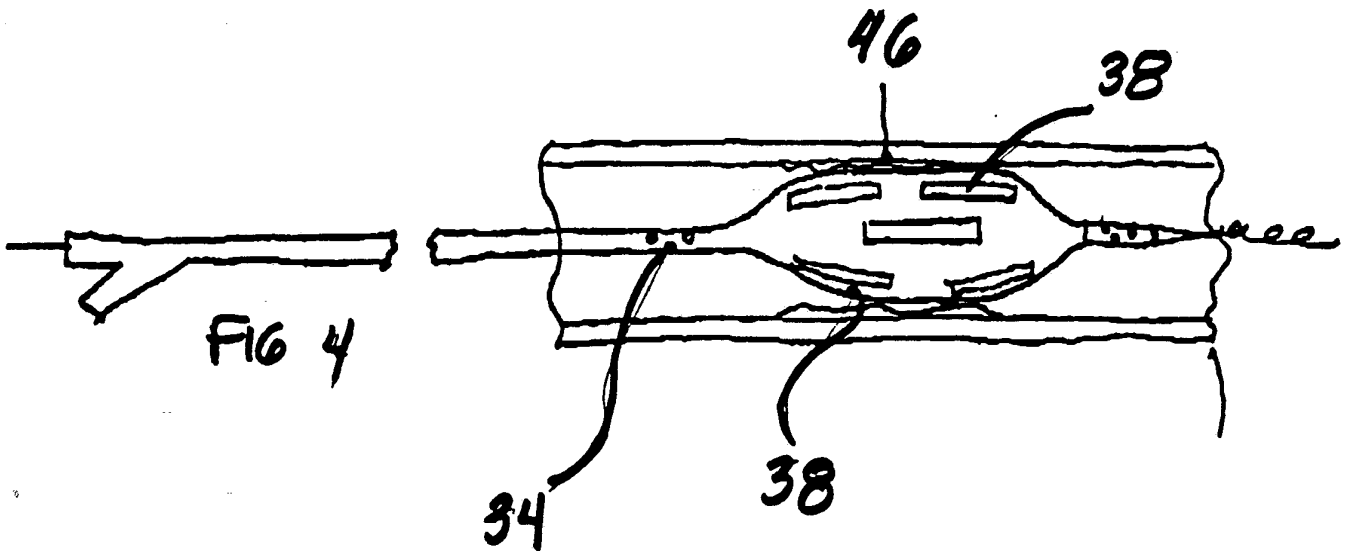
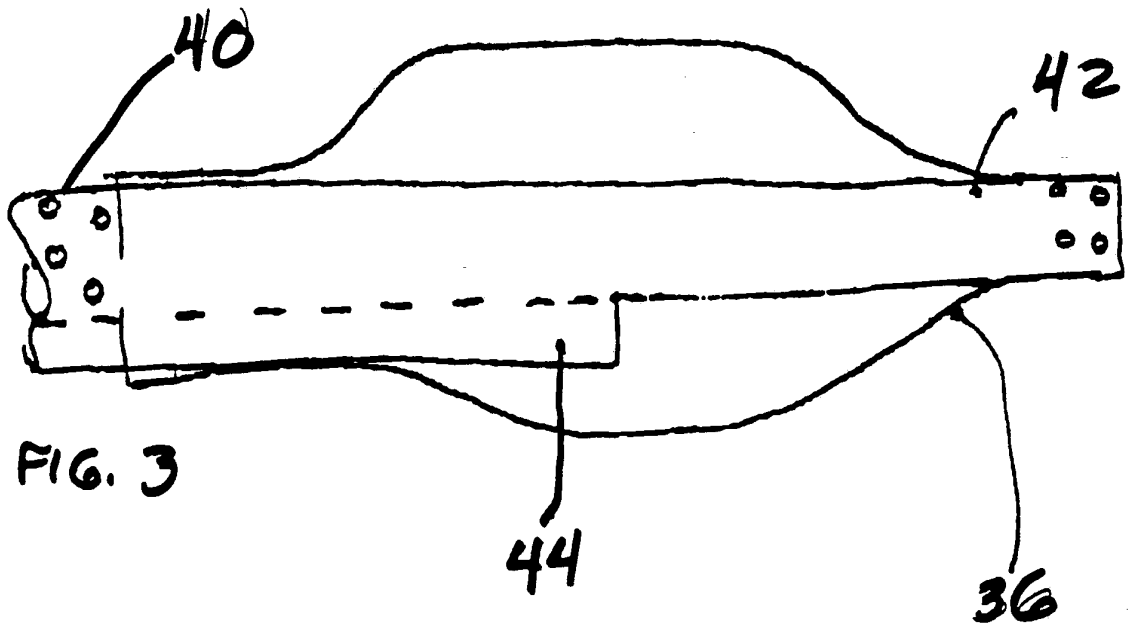
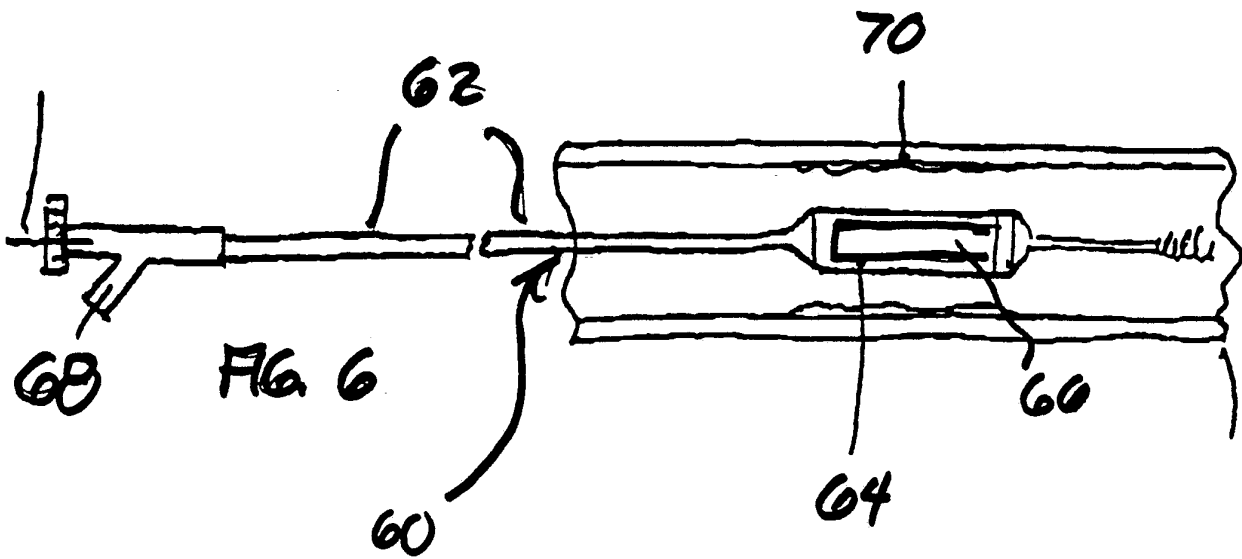
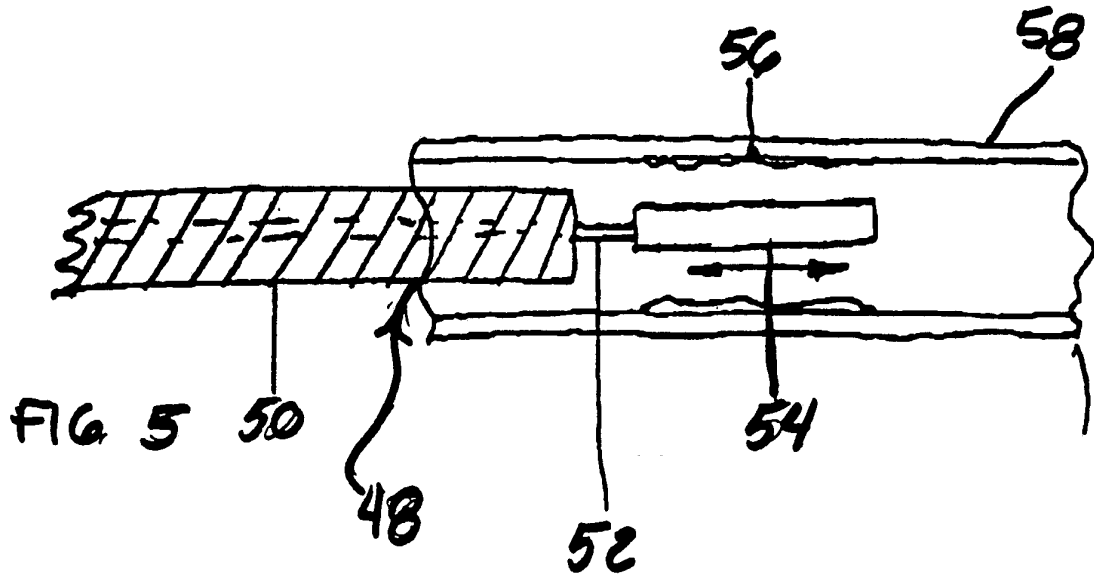

FIG. 2





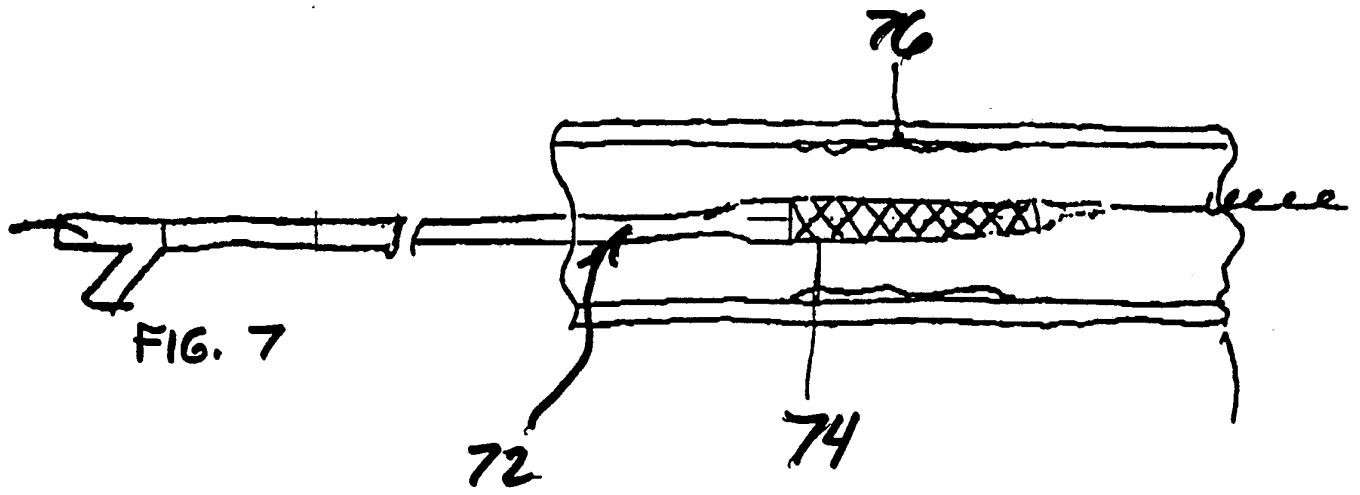

FIG. 7

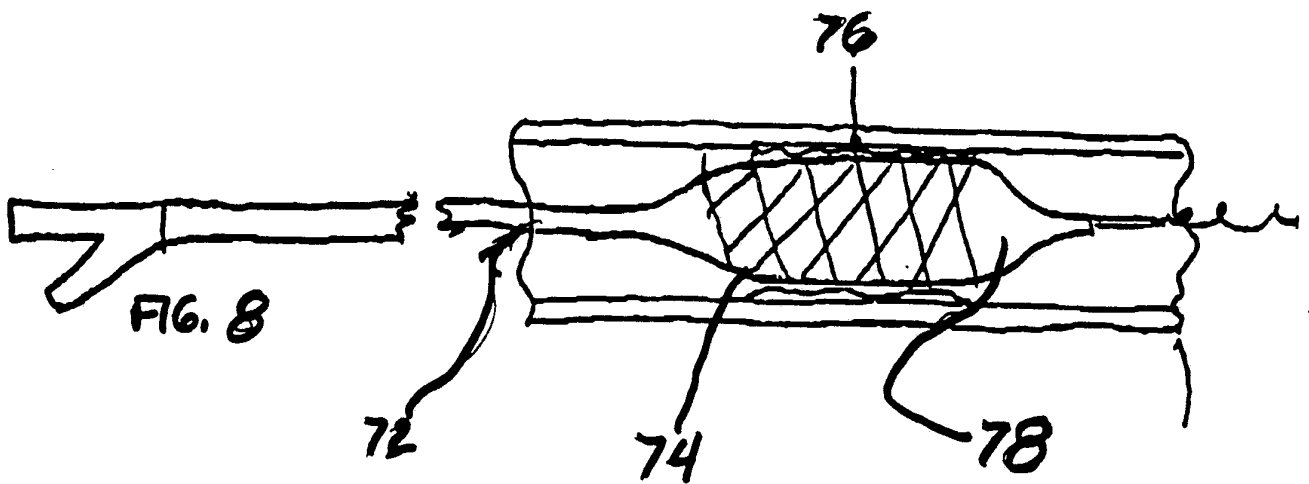

FIG. 8

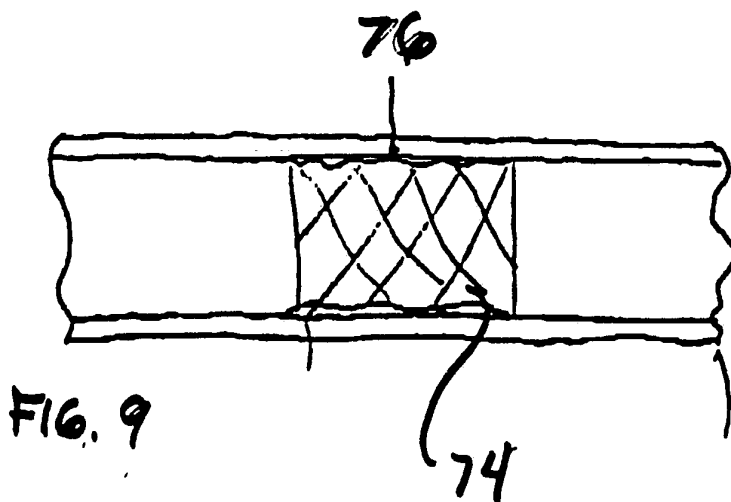

FIG. 9



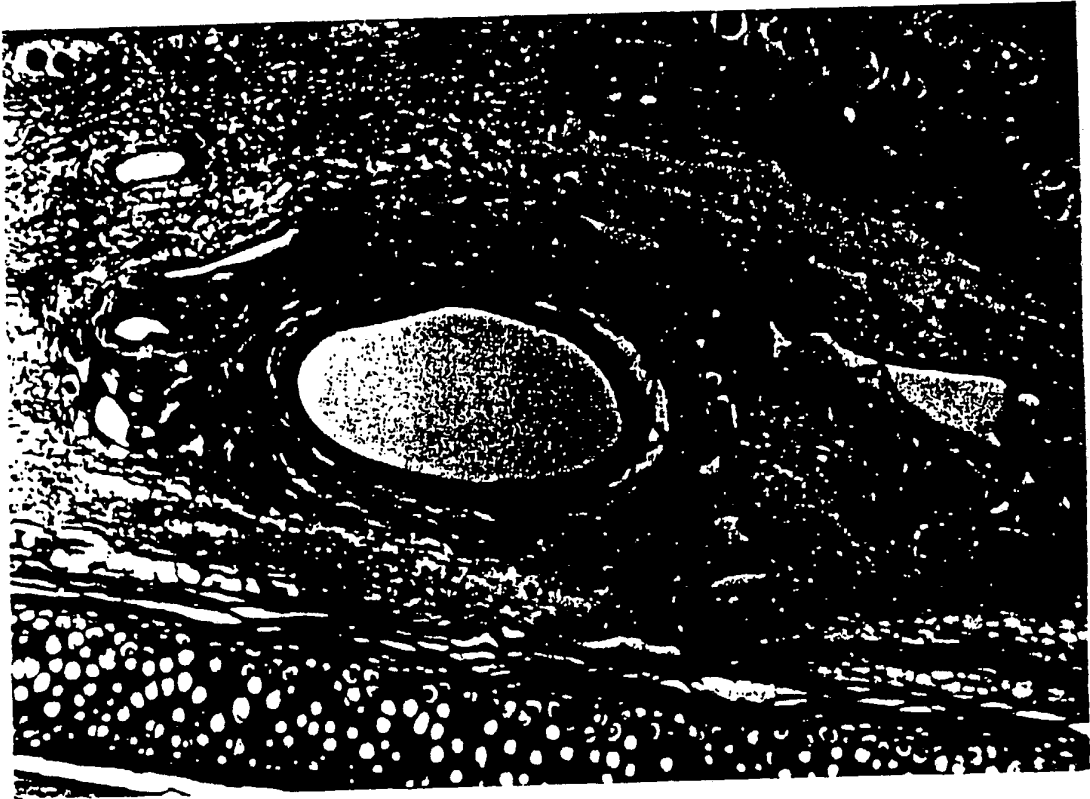

FIG. 10

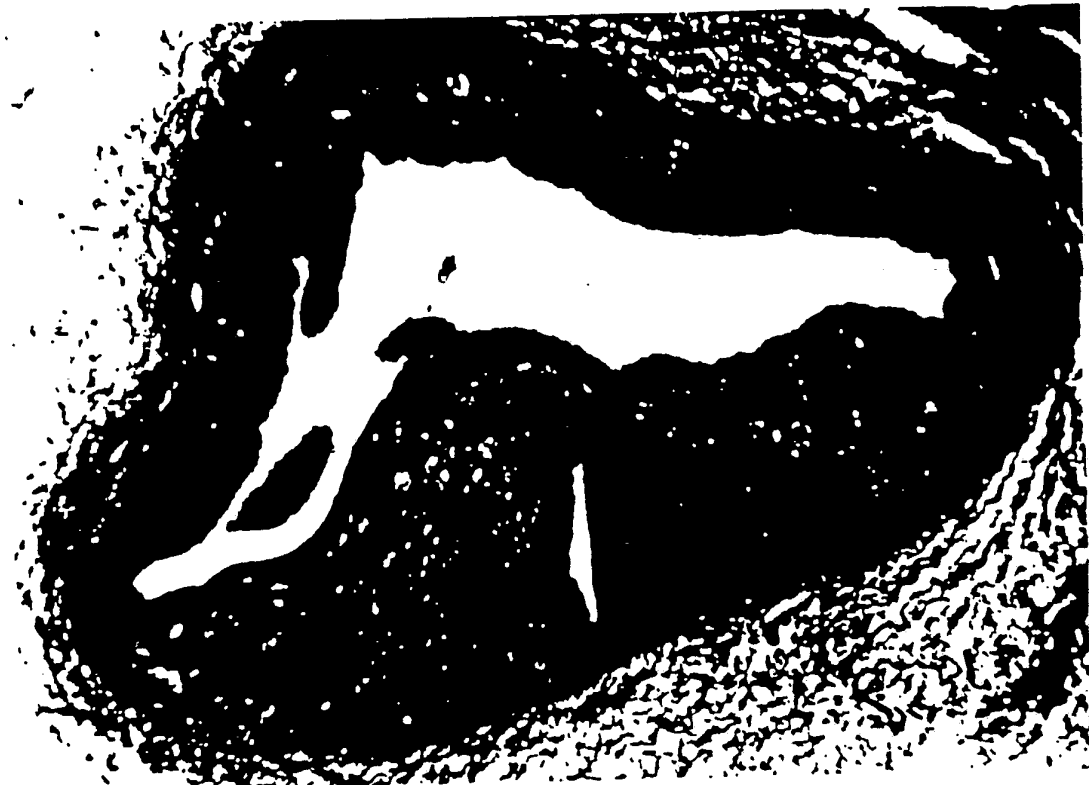

FIG. 11

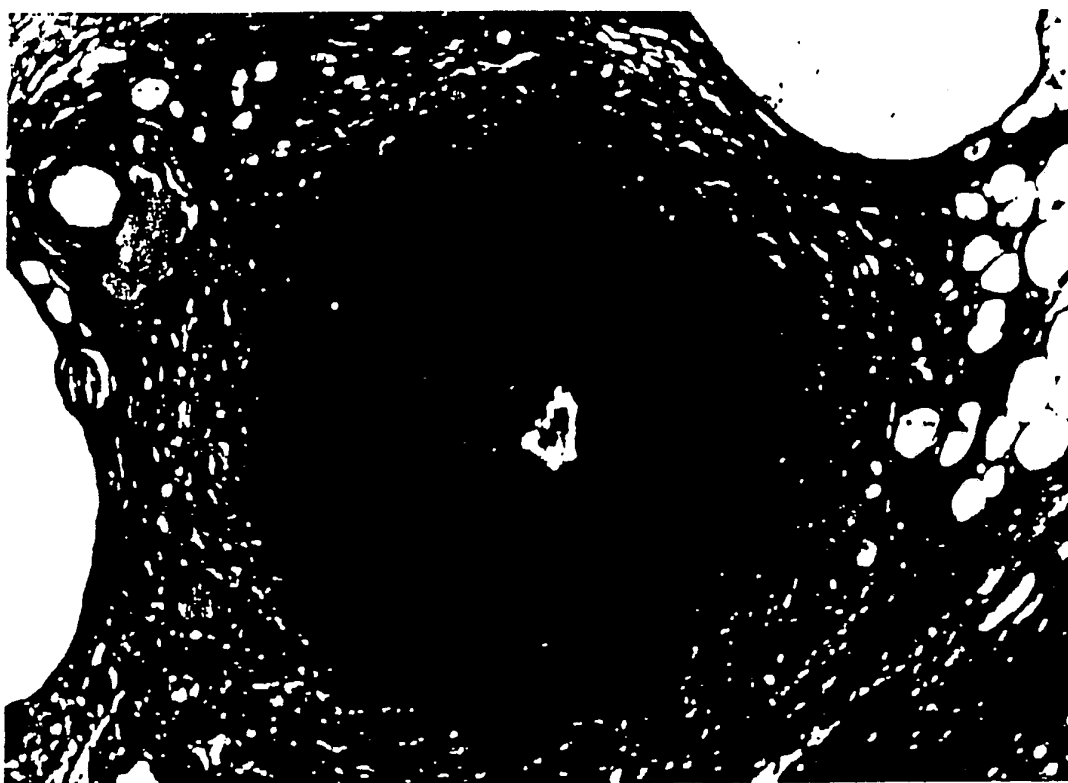

FIG. 12

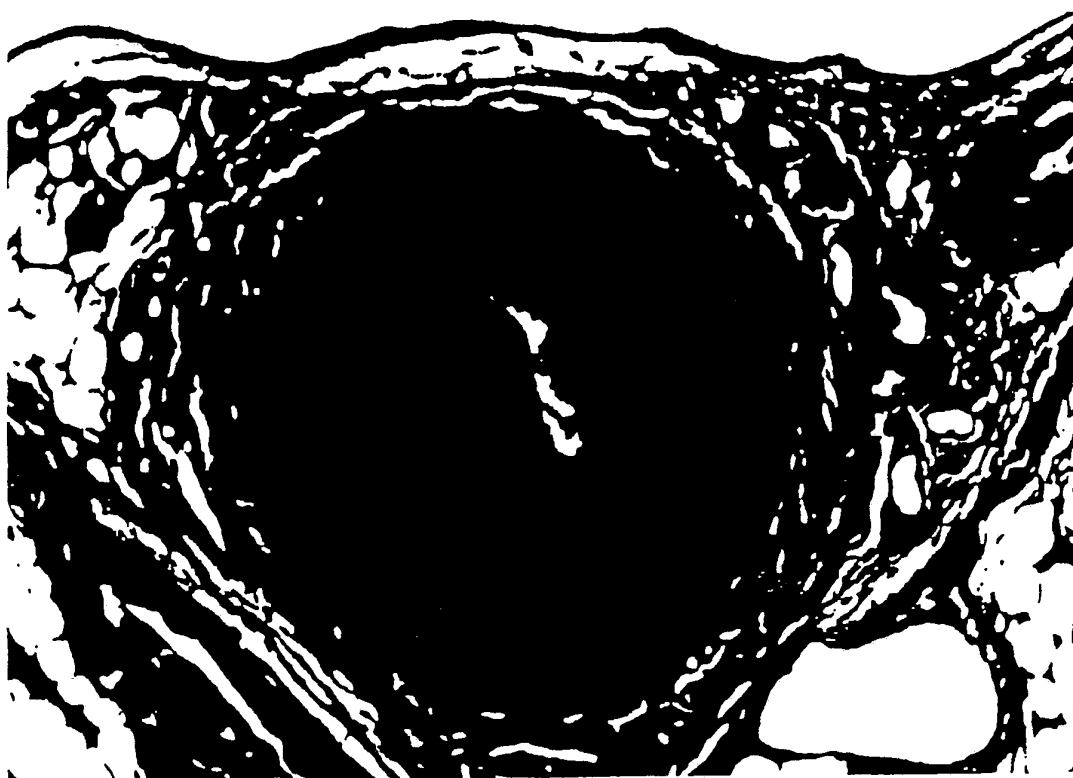

FIG. 13

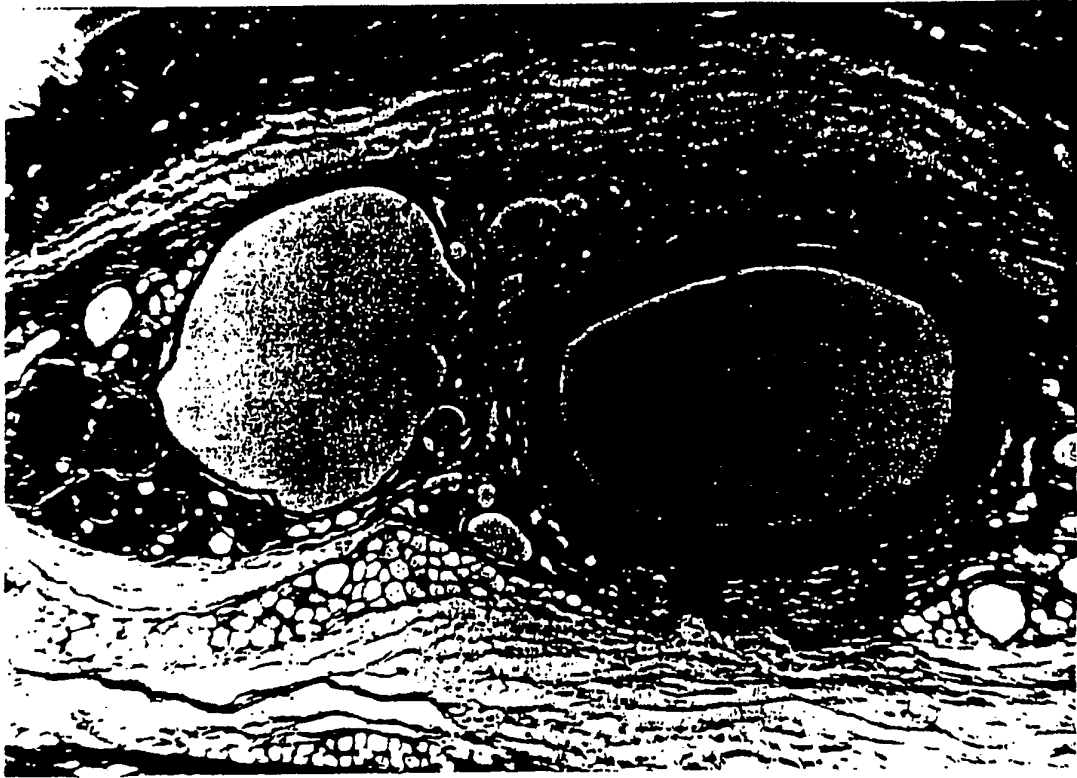

FIG. 14

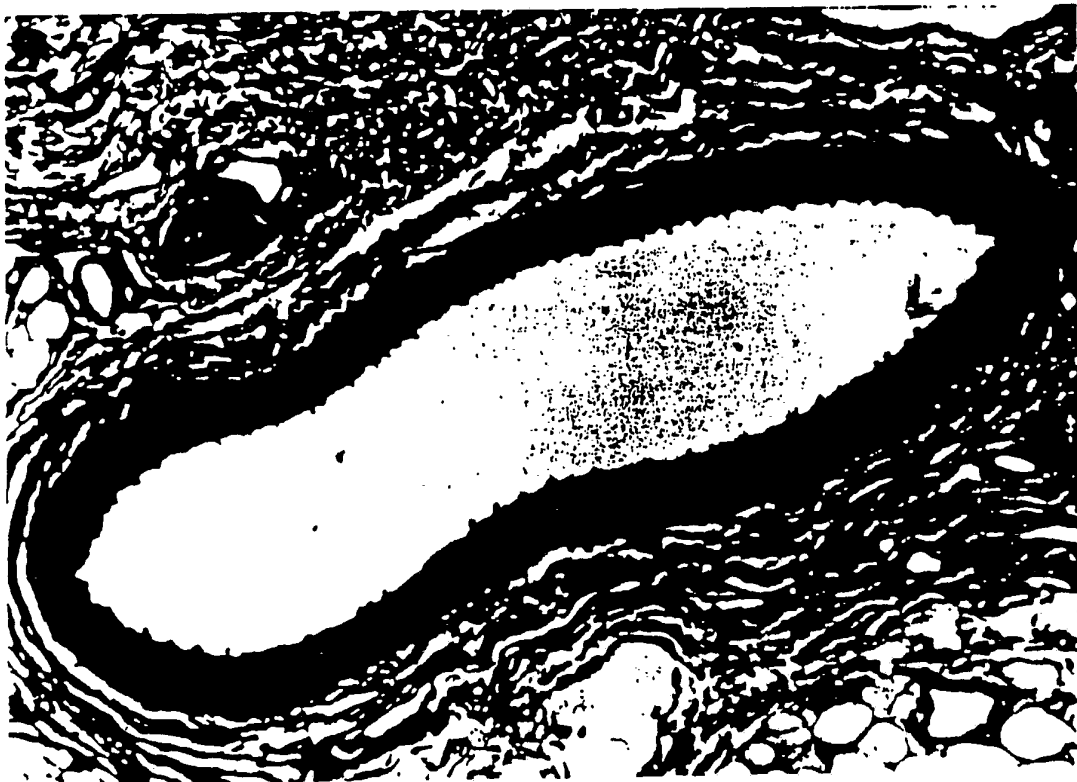
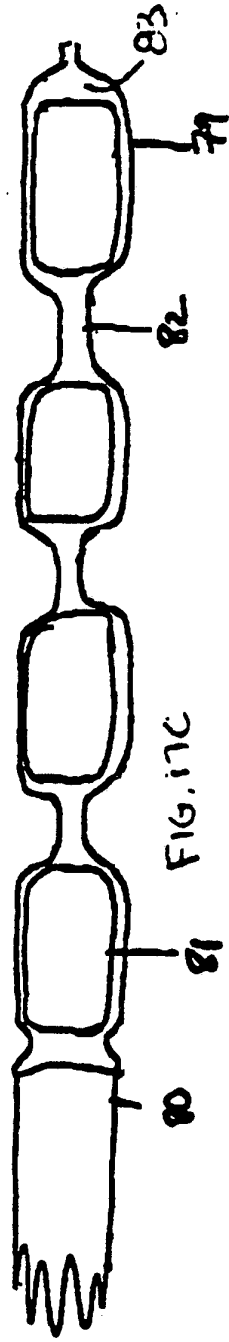
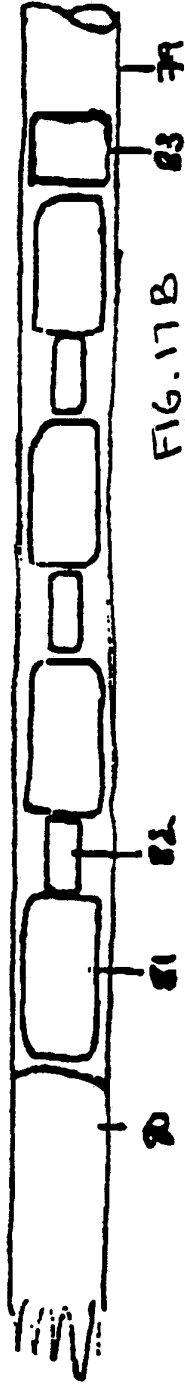
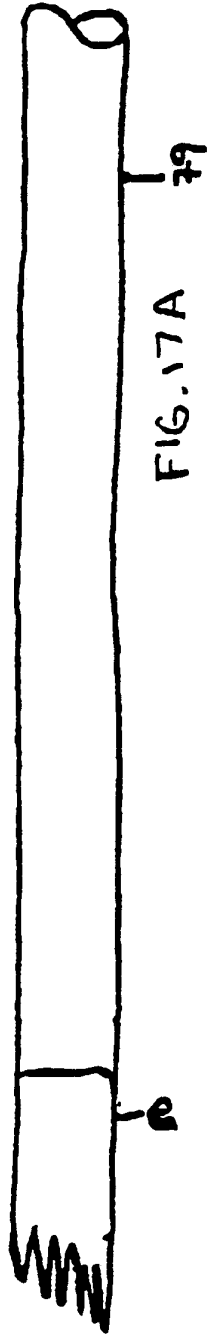

FIG. 15



FIG. 16



INTERNATIONAL SEARCH REPORT

International application No.  
PCT/US92/07447

**A. CLASSIFICATION OF SUBJECT MATTER**  
 IPC(5) :A61N 5/00  
 US CL :600/003  
 According to International Patent Classification (IPC) or to both national classification and IPC

**B. FIELDS SEARCHED**  
 Minimum documentation searched (classification system followed by classification symbols)  
 U.S. : 600/001-008  
 606/007  
 Documentation searched other than minimum documentation to the extent that such documents are included in the fields searched  
 Electronic data base consulted during the international search (name of data base and, where practicable, search terms used)

**C. DOCUMENTS CONSIDERED TO BE RELEVANT**

Category*	Citation of document, with indication, where appropriate, of the relevant passages	Relevant to claim No.
X,P Y	US,A, 5,059,166 (FISCHELL ET AL) 22 OCTOBER 1991 See entire document	1-2,4-5,7-9,12- 13,19,21-23,38,42 3,6,10-11,14- 18,20,24-37,39- 41,43-51
Y	US,A, 4,733,665 (PALMAZ) 29 MARCH 1988 See entire document	3,11

Further documents are listed in the continuation of Box C.  See patent family annex.

* Special categories of cited documents:	"I"	later document published after the international filing date or priority date and not in conflict with the application but cited to understand the principle or theory underlying the invention
"A" document defining the general state of the art which is not considered to be part of particular relevance	"N"	document of particular relevance; the claimed invention cannot be considered novel or cannot be considered to involve an inventive step when the document is taken alone
"E" earlier document published on or after the international filing date	"Y"	document of particular relevance; the claimed invention cannot be considered to involve an inventive step when the document is combined with one or more other such documents, such combination being obvious to a person skilled in the art
"L" document which may throw doubts on priority claim(s) or which is cited to establish the publication date of another citation or other special reason (as specified)	"&"	document member of the same patent family
"O" document referring to an oral disclosure, use, exhibition or other means		
"P" document published prior to the international filing date but later than the priority date claimed		

Date of the actual completion of the international search 16 OCTOBER 1992	Date of mailing of the international search report 08 DEC 1992
--	---

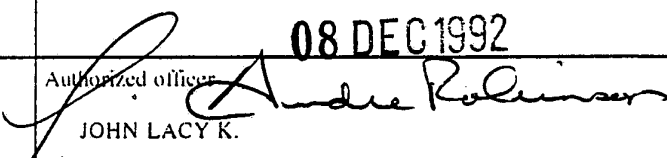
Name and mailing address of the ISA/ Commissioner of Patents and Trademarks Box PCT Washington, D.C. 20231 Facsimile No. NOT APPLICABLE	Authorized officer  JOHN LACY K. Telephone No. (703) 308-0858
---	--

## INTERNATIONAL SEARCH REPORT

International application No.  
PCT/US92/07447

## C (Continuation). DOCUMENTS CONSIDERED TO BE RELEVANT

Category*	Citation of document, with indication, where appropriate, of the relevant passages	Relevant to claim No.
Y	US,A, 4,588,395 (LEMELSON) 13 MAY 1986 See entire document	6,10
Y	US,A, 4,434,788 (NAKATSUGAWA) 06 MARCH 1984 See entire document	14-18,24-37,39- 41,43-51
A	US,A, 4,202,323 (ZWEIG ET AL) 13 MAY 1980 See entire document	