



- (51) International Patent Classification: C07C 2/84 (2006.01) C07C 11/04 (2006.01)
- (21) International Application Number: PCT/US2014/052722
- (22) International Filing Date: 26 August 2014 (26.08.2014)
- (25) Filing Language: English
- (26) Publication Language: English
- (30) Priority Data:  
61/872,175 30 August 2013 (30.08.2013) US  
13189746.4 22 October 2013 (22.10.2013) EP
- (71) Applicant: EXXONMOBIL CHEMICAL PATENTS INC. [US/US]; 5200 Bayway Drive, Baytown, TX 77520-2101 (US).
- (72) Inventors: HENAO, Juan, D.; 5925 Alameda Rd #10915, Houston, TX 77004 (US). KEUSENKOTHEN, Paul, F.; 408 Hawthorne Street, Houston, TX 77006 (US). PATIL, Abhimanyu, O.; 12 Evergreen Court, Westfield, NJ 07090 (US).
- (74) Agents: HUGHES, Gerard, J. et al.; Exxonmobil Chemical Company, Law Technology, P.O. Box 2149, Baytown, TX 77522-2149 (US).
- (81) Designated States (unless otherwise indicated, for every kind of national protection available): AE, AG, AL, AM, AO, AT, AU, AZ, BA, BB, BG, BH, BN, BR, BW, BY, BZ, CA, CH, CL, CN, CO, CR, CU, CZ, DE, DK, DM, DO, DZ, EC, EE, EG, ES, FI, GB, GD, GE, GH, GM, GT, HN, HR, HU, ID, IL, IN, IR, IS, JP, KE, KG, KN, KP, KR, KZ, LA, LC, LK, LR, LS, LT, LU, LY, MA, MD, ME, MG, MK, MN, MW, MX, MY, MZ, NA, NG, NI, NO, NZ, OM, PA, PE, PG, PH, PL, PT, QA, RO, RS, RU, RW, SA, SC, SD, SE, SG, SK, SL, SM, ST, SV, SY, TH, TJ, TM, TN, TR, TT, TZ, UA, UG, US, UZ, VC, VN, ZA, ZM, ZW.
- (84) Designated States (unless otherwise indicated, for every kind of regional protection available): ARIPO (BW, GH, GM, KE, LR, LS, MW, MZ, NA, RW, SD, SL, ST, SZ, TZ, UG, ZM, ZW), Eurasian (AM, AZ, BY, KG, KZ, RU, TJ, TM), European (AL, AT, BE, BG, CH, CY, CZ, DE, DK, EE, ES, FI, FR, GB, GR, HR, HU, IE, IS, IT, LT, LU, LV, MC, MK, MT, NL, NO, PL, PT, RO, RS, SE, SI, SK,

[Continued on next page]

(54) Title: CATALYTIC ALKANE CONVERSION AND OLEFIN SEPARATION

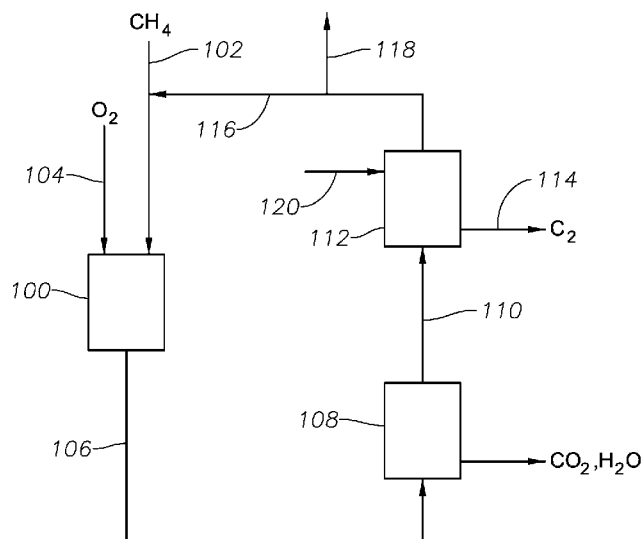

FIG. 1

(57) Abstract: Disclosed is a hydrocarbon conversion process that is less energy intensive than comparable processes. The hydrocarbon conversion process is particularly desirable for converting alkanes, such as methane into C<sub>2</sub>+olefins, such as ethylene and propylene, particularly with increasing selectivity to ethylene production. It is also desirable for effectively removing a C<sub>2</sub>Composition (i.e., ethane, ethylene and/or acetylene) produced from the catalytic conversion of hydrocarbon comprised of C<sub>2</sub>+olefins by exposing the reaction mixture to one sorbent under kinetic sorption. In addition, the hydrocarbon process is desirable for providing a substantially non-cryogenic separation of the desired C<sub>2</sub>Compositions from the hydrocarbons (e.g., methane) present in the reaction mixture.

WO 2015/031370 A1



SM, TR), OAPI (BF, BJ, CF, CG, CI, CM, GA, GN, GQ, GW, KM, ML, MR, NE, SN, TD, TG).

— before the expiration of the time limit for amending the claims and to be republished in the event of receipt of amendments (Rule 48.2(h))

**Published:**

— with international search report (Art. 21(3))

## CATALYTIC ALKANE CONVERSION AND OLEFIN SEPARATION

### CROSS-REFERENCE TO RELATED APPLICATION

[0001] This application claims priority to and the benefit of (i) U.S. Provisional Patent Application No. 61/872175, filed August 30, 2013; (ii) E.P. Patent Application No. 13189746.4, filed October 22, 2013; the contents of which are incorporated herein by reference in their entireties. The following related cases are also incorporated by reference in their entireties: (i) P.C.T. Patent Application No. \_\_\_\_\_, (Docket No. 2014EM205PCT), filed August 26, 2014; (ii) U.S. Patent Application No. \_\_\_\_\_, (Docket No. 2014EM205US), filed August 26, 2014, (iii) P.C.T. Patent Application No. \_\_\_\_\_, (Docket No. 2014EM206PCT), filed August 26, 2014; (iv) U.S. Patent Application No. \_\_\_\_\_, (Docket No. 2014EM206US), filed August 26, 2014; (v) P.C.T. Patent Application No. \_\_\_\_\_, (Docket No. 2013EM242PCT), filed August 26, 2014; (vi) U.S. Patent Application No. \_\_\_\_\_, (Docket No. 2013EM242/2US), filed August 26, 2014; and (vii) U.S. Patent Application No. \_\_\_\_\_ (Docket No. 2014EM228US), filed August 26, 2014.

### FIELD OF THE INVENTION

[0002] The invention relates to catalytically converting alkane and oxidant to produce unsaturated hydrocarbon. The invention further relates to processes for catalytically converting alkane to produce C<sub>2+</sub> unsaturates, to equipment useful in such processes, and to processes for removing a C<sub>2</sub> composition produced from the catalytic conversion.

### BACKGROUND OF THE INVENTION

[0003] Producing ethylene by methane dehydrogenation is an energy-intensive reaction. Since the reaction is endothermic and reaction temperatures greater than 800°C are generally required to achieve practical methane conversion levels, a significant amount of heat is required to maintain the reaction. Generating this heat and transferring it to the methane is a significant cost and can introduce inefficiencies into the process. In order to overcome some of these difficulties, there has been considerable effort directed toward methane conversion via catalytic oxidative coupling reactions.

[0004] One process for producing ethylene from methane by catalytic oxidative coupling is disclosed in *Synthesis of Ethylene via Oxidative Coupling of Methane*, G.E. Keller and M.H. Bhasin, Journal of Catalysis 73, 9-19 (1982). Although an appreciable selectivity to ethylene was observed (to a maximum of about 50%), conversion was relatively low. In order to overcome the methane-ethylene separation difficulties resulting from the low methane conversion, technology has been developed for quenching the reaction product

downstream of the oxidative coupling reactor, and then separating ethylene from the unreacted methane.

**[0005]** One process, disclosed in *Enhanced C<sub>2</sub> Yields from Methane Oxidative Coupling by Means of a Separative Chemical Reactor*, A.E. Tonkovich, R.W. Carr, R. Aris, *Science* 262, 221-223, 1993, includes a simulated countercurrent moving-bed chromatographic reactor, and achieves 65% methane conversion and 80% selectivity to C<sub>2</sub> hydrocarbons. The reactor is configured in four sections, with each section comprising (i) a catalytic reactor containing Sm<sub>2</sub>O<sub>3</sub> catalyst and (ii) an adsorbent column located downstream of the catalytic reactor. Methane and oxygen react via catalytic oxidative coupling in the reactor at a temperature in the range of about 900°K to 1100°K, and then ethylene is separated from unreacted methane in the sorption column. In order to maintain sufficient selectivity for ethylene sorption, the reactor's product is quenched to a temperature of 373°K in the sorption column. In another process, disclosed in *Methane to Ethylene with 85 Percent Yield in a Gas Recycle Electrocatalytic Reactor-Separator*, Y. Jiang, I.V. Yentekakis, C.G. Vayenas, *Science* 264, 1563-1566, 1994, gas recycle is utilized to further increase methane conversion, but an even lower quench temperature (30°C) is used during ethylene sorption.

**[0006]** Although the disclosed moving-bed and gas-recycle processes improve conversion, the quenching is energy intensive, and further improvements are desired. Further improvements are particularly desired in converting alkanes such as methane into C<sub>2+</sub> olefins such as ethylene and propylene, particularly with increasing selectivity to ethylene production.

**[0007]** Separation of the C<sub>2</sub> components from the reaction mixture produced by the methane dehydrogenation process is also energy intensive in that cryogenic separation techniques are generally employed. Cryogenic separation involves the fractional distillation of components in a component mixture, in which the component mixture has been cooled to very low temperatures in order to separate the various components. Since methane dehydrogenation processes typically produce reaction mixtures comprising multiple components such as ethylene, ethane, acetylene, propylene and carbon dioxide, as well as unreacted methane, and these types of components have very low boiling points, cryogenic separation is typically used in order to separate the individual components. Cryogenic separation generally requires refrigeration on the order of -150°C to -100°C in order to liquefy certain components, which is necessary in order to separate the various components. Thus, a substantial amount of energy is needed to reach appropriate cryogenic separation conditions.

[0008] U.S. Patent Pub. No. 2014/0018589 to Iyer et al. discloses systems and methods for reacting methane in an oxidative coupling of methane (“OCM”) process to yield products comprising hydrocarbon compounds with two or more carbon atoms (also “C<sub>2+</sub> compounds”), and separating the products into streams for use in various downstream processes. The product stream is sent to a dryer to remove water, then to a nitrogen removal unit (NRU) to selectively adsorb nitrogen from the hydrocarbons by pressure swing adsorption. The remaining hydrocarbon product is then compressed and sent to a refrigeration unit to separate the C<sub>3+</sub>, ethane, ethylene and methane components. The hydrocarbon products can be separated with less use of refrigeration, e.g., by using relatively smaller refrigeration units, provided water, CO<sub>2</sub>, and nitrogen are removed from the reaction products. But even with these improvements, cryogenic (i.e., very low temperature) separation is still required to separate the particularly desired C<sub>2</sub> components and produce a C<sub>2</sub> rich product. It is desired to lessen or substantially eliminate the need for cryogenic separation, to achieve a more energy-efficient separation of the reaction mixture’s C<sub>2</sub> components. In particular, further improvements are desired to achieve a substantially non-cryogenic separation of the C<sub>2</sub> components from the reaction mixtures.

#### **SUMMARY OF THE INVENTION**

[0009] This invention provides a more energy-efficient hydrocarbon conversion process than comparable processes. The hydrocarbon conversion process is particularly desirable for converting alkanes such as methane into C<sub>2+</sub> olefins such as ethylene and propylene, particularly with increasing selectivity to ethylene production. In addition, the hydrocarbon process is desirable for providing a substantially non-cryogenic separation of the C<sub>2</sub> components from the hydrocarbons (e.g., methane) present in the reaction mixture.

[0010] More particularly, the invention relates to a process for producing and isolating a C<sub>2</sub> composition. The process includes a step of providing a hydrocarbon reactant and an oxidant, wherein the hydrocarbon reactant comprises  $\geq 10\%$  alkane, e.g., methane, (molar basis, per mole of hydrocarbon reactant). At least a portion of the hydrocarbon reactant’s alkane (e.g., methane) is catalytically converted in the presence of the oxidant and a hydrocarbon conversion catalyst to produce a reaction mixture comprising (A) a C<sub>2</sub> composition produced by the catalytic conversion, (B) water and/or CO<sub>2</sub> produced during the catalytic conversion, and (C) unconverted alkane (e.g., methane). The reaction mixture is exposed, under kinetic sorption conditions, to at least one sorbent to selectively remove from the reaction mixture at least a portion of the reaction mixture’s C<sub>2</sub> composition to produce a

C<sub>2</sub> lean mixture. The C<sub>2</sub> lean mixture comprises at least a portion of the unconverted alkane (methane) and has a C<sub>2</sub> content that is less than that of the reaction mixture. The sorbent comprises at least one C<sub>2</sub> selective sorbent. The reaction mixture is exposed to the C<sub>2</sub> selective sorbent a temperature of  $\geq 50^{\circ}\text{C}$ .

**[0011]** In certain aspects, the process further comprises selectively removing at least a portion of the reaction mixture's CO<sub>2</sub>, the CO<sub>2</sub> removal being carried out before exposing the reaction mixture to the C<sub>2</sub> selective sorbent. Alternatively or in addition, the process can include a step of selectively removing from the reaction mixture at least a portion of any water, the water removal being carried out before exposing the reaction mixture to the C<sub>2</sub> selective sorbent. The process can further include a step of desorbing a desorb composition from the C<sub>2</sub> selective sorbent after step (c), wherein the desorb composition comprises methane, ethane, and ethylene, and exposing the desorb composition to at least one olefin-selective sorbent under kinetic sorption conditions to selectively remove from the desorb composition at least a portion of the desorb composition's ethylene.

**[0012]** In certain aspects, the hydrocarbon reactant comprises  $\geq 90\%$  methane and the conversion catalyst comprises at least one oxidative coupling catalyst. The hydrocarbon reactant can further comprise  $\geq 1\%$  C<sub>2+</sub> alkane (molar basis, per mole of hydrocarbon reactant) and the conversion catalyst comprises at least one oxidative coupling catalyst and at least one oxydehydrogenation catalyst.

**[0013]** In certain aspects, the oxidant comprises O<sub>2</sub> and the catalytic conversion is carried out at a methane : O<sub>2</sub> molar ratio of  $> 2:1$ . Alternatively, the oxidant can comprise  $\geq 20\%$  O<sub>2</sub> (molar basis, per mole of oxidant) and the catalytic conversion can be carried out at a methane : O<sub>2</sub> molar ratio of  $\geq 4:1$ .

**[0014]** In certain aspects, (i) the oxidant can comprise  $\geq 90\%$  O<sub>2</sub> (molar basis, per mole of oxidant), (ii) the hydrocarbon reactant can comprise  $\geq 90\%$  methane (molar basis, per mole of hydrocarbon reactant), and (iii) the hydrocarbon can further comprise  $\geq 1\%$  of one or more C<sub>2</sub> to C<sub>5</sub> linear, iso, and cyclo alkane (molar basis, per mole of hydrocarbon reactant).

**[0015]** In certain aspects, the C<sub>2</sub> selective sorbent comprises at least one transition metal that exhibits  $\pi$ -complexation with olefins and has an electron affinity  $\geq 1.0$  eV. The C<sub>2</sub> selective sorbent can include at least one shape-selective material. For example, the C<sub>2</sub> selective sorbent can include at least one molecular sieve. The C<sub>2</sub> selective sorbent can be an olefin-selective sorbent having chemoselectivity and shape selectivity.

**[0016]** In other aspects, the process for producing and isolating a C<sub>2</sub> composition

comprises (a) providing first and second hydrocarbon reactants and first and second oxidants, wherein the first and second hydrocarbon reactants each comprise  $\geq 10\%$  methane (molar basis, per mole of hydrocarbon reactant) and the first and second oxidants each comprise  $O_2$ ; and (b) catalytically converting at least a portion of the first hydrocarbon reactant in the presence of the first oxidant and a hydrocarbon conversion catalyst to produce a first reaction mixture comprised of (A) a  $C_2$  composition produced by the catalytic conversion, (B) water and/or  $CO_2$  produced during the catalytic conversion, and (C) unconverted methane. The reaction mixture is exposed to at least one sorbent under kinetic sorption conditions to selectively remove from the first reaction mixture at least a portion of the first reaction mixture's  $C_2$  composition to produce a first  $C_2$  lean mixture comprised of at least a portion of the unconverted methane. The catalytic conversion can be carried out in a first time interval, with further catalytic conversion being carried out in a second time interval following the first time interval. In the second time interval, a second reaction mixture is produced by catalytically converting at least a portion of the second hydrocarbon reactant in the presence of the second oxidant and the hydrocarbon conversion catalyst, with the second reaction mixture comprising (A) a  $C_2$  composition produced by the catalytic conversion, (B) water and/or  $CO_2$  produced during the catalytic conversion, and (C) unconverted methane. The second reaction mixture is exposed to at least one sorbent under kinetic sorption conditions to selectively remove from the second reaction mixture at least a portion of the second reaction mixture's  $C_2$  composition to produce a second  $C_2$  lean mixture.

**[0017]** Catalytic conversion can be carried out in a reverse-flow reactor. The reverse flow reactor can include first and second regions, the first region contains at least a portion of the hydrocarbon conversion catalyst, and the second region contains at least a portion of the  $C_2$  selective sorbent.

**[0018]** Other aspects of the invention further relate to a hydrocarbon conversion system for producing a  $C_2$  composition, which includes a reactor in fluid communication with a sorption system. The reactor comprises: (i) a first region having a first thermal mass and a first aperture, (ii) a second region having a second thermal mass and a second aperture, and (iii) a catalytic conversion zone containing catalyst having an oxidative coupling functionality, oxydehydrogenation functionality or both, with at least a portion of the catalyst being deposited on or in at least one of the first thermal mass and second thermal mass. The first and second regions are configured for flowing a feed mixture to enter the reactor proximate to the first aperture, with one or more components of a reaction mixture exiting the

reactor proximate to the second aperture. A sorption system, which operates under kinetic sorption conditions, is configured to be in fluid communication with the second aperture for receiving at least a portion of the catalytically converted reaction mixture. The sorption system includes at least one C<sub>2</sub> selective sorbent.

[0019] In certain aspects of the hydrocarbon conversion system, the reactor is a reverse-flow reactor in which the first and second regions of the reverse-flow reactor are configured for flowing a first flow of a first feed mixture to enter the reactor proximate to the first aperture of the first thermal mass, with one or more components of a first reaction mixture exiting the reactor proximate to the second aperture of the second thermal mass. The reverse-flow reactor is further configured for flowing a second flow of a second feed mixture to enter the reactor proximate to the second aperture of the second thermal mass, with one or more components of the second reaction mixture exiting the reactor proximate to the first aperture.

#### **BRIEF DESCRIPTION OF THE DRAWINGS**

[0020] FIG. 1 is a simplified diagrammatic illustration of a generalized system for selectively removing a C<sub>2</sub> composition according to certain aspects of the invention.

[0021] FIG. 2 is a simplified diagrammatic illustration of a more particular system for selectively removing a C<sub>2</sub> composition according to certain aspects of the invention.

[0022] FIGS. 3A and 3B are simplified diagrammatic illustrations of a generalized reverse-flow reactor system, which can be used to carry the conversion reaction to produce C<sub>2+</sub> olefins and C<sub>2</sub> compositions.

[0023] Although the invention can be described in terms of a hydrocarbon conversion process, particularly an oxidative coupling reaction process, for producing olefins such as ethylene and propylene, the invention is not limited thereto. In other words, to the extent that the following detailed description is specific to a particular aspect or a particular use, this is intended to be illustrative only, and is not to be construed as limiting the scope of the invention. On the contrary, it is intended to cover all alternatives, modifications and equivalents that may be included within the spirit and scope of the invention.

#### **DETAILED DESCRIPTION OF THE INVENTION**

##### **I. Introduction and Definitions**

[0024] This invention is directed to a relatively low-energy process for removing, i.e., separating and recovering, a C<sub>2</sub> composition produced from the catalytic conversion of hydrocarbon. The catalytic conversion reaction involves catalytically converting alkane to produce C<sub>2+</sub> hydrocarbon, particularly C<sub>2+</sub> unsaturated hydrocarbon, and more particularly



ethylene. The C<sub>2</sub> composition that is separated from the C<sub>2+</sub> hydrocarbon is predominantly C<sub>2</sub> unsaturated hydrocarbon, i.e., ethylene and optionally ethylene and/or acetylene. The process is highly efficient for converting alkane, such as methane, to produce the specified C<sub>2</sub> composition. The process is also highly energy efficient in that a substantial portion of the specified C<sub>2</sub> composition can be recovered without having to rely on energy-intensive cryogenic separation.

**[0025]** The hydrocarbon reactant and an oxidant are supplied to a reactor for carrying out the process. The hydrocarbon reactant comprises alkane, e.g., C<sub>5-</sub> alkane, such as methane. The hydrocarbon reactant can comprise a single component, e.g., methane. In aspects where the hydrocarbon reactant comprises a plurality of components, each component (e.g., methane and ethane) can be supplied to the reactor as a separate stream. In other aspects, the hydrocarbon reactant is provided to the reactor as a mixed stream.

**[0026]** At least a portion of the hydrocarbon reactant's alkane is catalytically converted in the presence of oxidant and a hydrocarbon conversion catalyst to produce a reaction mixture comprised of the specified C<sub>2</sub> composition, which is produced by the alkane conversion. While not wishing to be bound by any theory or model, it is believed that the conversion is primarily the result of (i) one or more oxidative coupling reactions when the hydrocarbon reactant comprises methane and/or (ii) one or more oxydehydrogenation reactions when the hydrocarbon reactant comprises C<sub>2+</sub> alkane.

**[0027]** Besides the C<sub>2</sub> composition, the reaction mixture typically further comprises unconverted alkane and/or CO<sub>2</sub> produced during the alkane conversion. At least a portion of the reaction mixture's C<sub>2</sub> composition is removed by exposing the reaction mixture to at least one C<sub>2</sub> selective sorbent. Using a C<sub>2</sub> selective sorbent allows the removal and recovery of C<sub>2</sub> components from the reaction mixture, especially ethylene, at temperatures  $\geq 0^{\circ}\text{C}$ , such as  $\geq 50^{\circ}\text{C}$ . In other words, using a C<sub>2</sub> selective sorbent substantially obviates the need for cryogenic separation of C<sub>2</sub> compounds from the reaction mixture.

**[0028]** Exposing the reaction mixture to at least one C<sub>2</sub> selective sorbent results in the selective sorption of at least a portion of the reaction mixture's C<sub>2</sub> composition. This produces a C<sub>2</sub> lean mixture, which comprises at least a portion of the unconverted alkane. The C<sub>2</sub> lean mixture is "lean" in the sense that it has a C<sub>2</sub> content that is less than that of the reaction mixture. Although optional, it is efficient to remove at least a portion of the reaction mixture's CO<sub>2</sub> upstream of the separating at least a portion of the reaction mixture's C<sub>2</sub> composition upstream of the C<sub>2</sub> selective sorbent. Doing so beneficially lessens the vapor

loading on the C<sub>2</sub> selective sorbent, and also allows for the use of process equipment (e.g., conduits, sorbent containment vessels, compressors, etc.) of significantly smaller hydraulic capacity. For generally the same reasons, it is beneficial to remove any water present in the reaction mixture before the reaction mixture is exposed to the C<sub>2</sub> selective sorbent.

**[0029]** The specified hydrocarbon reactant is converted in at least one catalytic reactor. In certain aspects, the catalytic reactor comprises at least one reverse-flow catalytic reactor such as a tubular reverse-flow catalytic reactor. It is observed that selectivity to C<sub>2</sub> compositions and C<sub>2+</sub> olefins (particularly ethylene) can be increased when the hydrocarbon reactant's alkane comprises methane, e.g., when the hydrocarbon reactant comprises  $\geq 10\%$  methane (molar basis, per mole of hydrocarbon reactant). Aspects of the invention relating to the catalytic conversion of a hydrocarbon reactant comprising  $\geq 10\%$  methane (molar basis) in a tubular reverse flow catalytic reactor will now be described in more detail.

**[0030]** The invention additionally relates to a hydrocarbon conversion system and/or apparatus for producing a C<sub>2</sub> composition. The apparatus includes a reactor, such as a reverse-flow reactor and a C<sub>2</sub> selective sorption system. The reactor can comprise (i) a first region having a first thermal mass and a first aperture; (ii) a second region having a second thermal mass and a second aperture, and (iii) a catalytic conversion zone containing catalyst having an oxidative coupling functionality, oxydehydrogenation functionality or both, with at least a portion of the catalyst being deposited on or in at least one of the first thermal mass and second thermal mass. The first and second regions can be configured for flowing a first flow of a first feed mixture which enters the reactor proximate to the first aperture. One or more components of a first reaction mixture exit the reactor proximate to the second aperture. Optionally, the reactor can be further configured for flowing a second flow of a second feed mixture to enter the reactor proximate to the second aperture, with one or more components of the second reaction mixture exiting the reactor proximate to the first aperture. The C<sub>2</sub> selective sorption system is in fluid communication the first aperture, and optionally the second aperture, for receiving at least a portion of the catalytically converted reaction mixture, and optionally the second reaction mixture, with the C<sub>2</sub> selective sorption system including at least one C<sub>2</sub> selective sorbent.

**[0031]** The invention is not limited to these aspects, and this description is not meant to foreclose the use of other reactors and/or other hydrocarbon reactants within the broader scope of the invention. For the purpose of this description and appended claims, the following terms are defined:

**[0032]** A “C<sub>2</sub> selective sorbent” is a sorbent having a selectivity for [ethane + ethylene] sorption over that of methane that is greater than 1.0. When exposed under sorption conditions to a mixture comprising methane, ethane, and ethylene, C<sub>2</sub> selective sorbent having a selectivity for [ethane + ethylene] over methane of greater than 1.0 will retain > 50% of the mixture’s [ethane + ethylene] and ≤ 50% of the mixture’s methane. When a C<sub>2</sub> selective sorbent has a selectivity for [ethane + ethylene] over that of methane of greater than 5.0, the sorbent will retain > 83% of the mixture’s [ethane + ethylene]. The C<sub>2</sub> selective sorbent can have, e.g., a selectivity for [ethane + ethylene] over methane ≥ 9, such as ≥ 99, or ≥ 999, or ≥ 9999.

**[0033]** An “olefin-selective sorbent” is a sorbent having a selectivity for ethylene sorption over that of ethane that is greater than 1.0. When exposed under sorption conditions to a mixture comprising ethane and ethylene, an olefin-selective sorbent having a selectivity for ethylene over ethane of greater than 1.0 will retain > 50% of the mixture’s ethylene and ≤ 50% of the mixture’s ethane. When an olefin-selective sorbent has a selectivity for ethylene over ethane of greater than 5.0, the sorbent will retain > 83% of the mixture’s ethylene. The olefin-selective sorbent can have, e.g., a selectivity for ethylene over ethane ≥ 9, such as ≥ 99, or ≥ 999, or ≥ 9999.

**[0034]** A sorption carried out under “kinetic sorption conditions” is one where sorption is halted before equilibrium sorption conditions are achieved. Kinetic sorption conditions can be obtained, e.g., by operating the sorption at a higher rate per volume of sorbent, by shortening the length of the sorbent bed, etc.

**[0035]** The term “hydrocarbon” means compounds containing hydrogen bound to carbon, and encompasses (i) saturated hydrocarbon, (ii) unsaturated hydrocarbon, and (iii) mixtures of hydrocarbons, including mixtures of hydrocarbons (saturated and/or unsaturated) having different values of n.

**[0036]** The term “C<sub>n</sub>” hydrocarbon wherein n is a positive integer, e.g., 1, 2, 3, 4, or 5, means hydrocarbon having n carbon atom(s) per molecule.

**[0037]** The term “C<sub>n+</sub>” hydrocarbon wherein n is a positive integer, e.g., 1, 2, 3, 4, or 5, means hydrocarbon having at least n carbon atom(s) per molecule.

**[0038]** The term “C<sub>n-</sub>” hydrocarbon wherein n is a positive integer, e.g., 1, 2, 3, 4, or 5, means hydrocarbon having no more than n number of carbon atom(s) per molecule.

[0039] The term “alkane” means substantially saturated compounds containing hydrogen and carbon only, e.g., those containing  $\leq 1\%$  (molar basis) of unsaturated carbon atoms. The term alkane encompasses  $C_1$  to  $C_5$  linear, iso, and cyclo alkanes.

[0040] The term “unsaturate” means a  $C_n$  hydrocarbon containing at least one carbon atom directly bound to another carbon atom by a double or triple bond.

[0041] A  $C_2$  composition can be considered a composition comprised of at least one compound containing two carbon atoms. For example, a  $C_2$  composition can be a composition comprised of at least one compound selected from the group of ethane, ethylene and acetylene. Typically, the  $C_2$  composition comprises  $\geq 90\%$  (molar basis, per mole of  $C_2$  composition) of one or more of (i) ethane, (ii) ethylene, and (iii) acetylene, e.g.,  $\geq 95\%$ , such as  $\geq 99\%$ . For example, the  $C_2$  composition can comprise  $\geq 90\%$  of (i) ethane and (ii) ethylene, such as  $\geq 95\%$ , or  $\geq 99\%$ . The  $C_2$  composition can be one that predominantly comprises  $C_2$  unsaturates, e.g.,  $\geq 50\%$  of (i) ethylene and/or (ii) acetylene, such as  $\geq 75\%$ , or  $\geq 90\%$ , or  $\geq 99\%$ , with the balance comprising ethane, e.g.,  $< 50\%$  ethane, such as  $\leq 25\%$ , or  $\leq 10\%$ , or  $< 1\%$  ethane. One suitable  $C_2$  composition comprises 50% to 99% ethylene, with the balance comprising ethane, e.g., 75% to 99% ethylene, or 90% to 99% ethylene.

[0042] The term “Periodic Table” means the Periodic Chart of the Elements, as it appears on the inside cover of The Merck Index, Twelfth Edition, Merck & Co., Inc., 1996.

[0043] The term “oxidant” means any oxygen-bearing material which, under the conditions in the reaction zone, yields an oxygen atom for oxidative coupling and/or oxydehydrogenation. While not wishing to be limited to theory, molecular oxygen atom may be provided as a reactive gas in a gaseous zone and/or atomic oxygen may be provided from a catalyst surface as, for instance, reacted, sorbed forms.

[0044] The term “oxidative coupling” refers to the oxygen-assisted dehydrogenation and coupling (formation of C-C bonds) of alkane (particularly methane) to produce water and hydrocarbon of higher order, such as producing  $C_2$  hydrocarbon from methane.

[0045] The term “oxydehydrogenation” means oxygen-assisted dehydrogenation of an alkane, particularly a  $C_{2+}$  alkane, to produce an equivalent alkene and water without coupling.

[0046] The term “hydrocarbon conversion catalyst” means any catalyst having at least one of oxidative coupling functionality and oxydehydrogenation functionality.

[0047] The term “residence time” means the average time duration for non-reacting (non-converting by oxidative coupling) molecules (such as He,  $N_2$ , Ar) having a molecular weight

in the range of 4 to 40 to traverse the reactor or a defined zone within the reactor, such as a reaction zone of a oxidative coupling reactor.

[0048] The term “catalytic oxidative coupling reactor” means a reactor in which oxidative coupling and/or oxydehydrogenation reactions are carried out. Optionally,  $\geq 30.0\%$  of the heat utilized by the reactions are provided by heat transfer from reactor components, e.g., solid surfaces associated with the reactor, such as tubulars or bed materials; optionally  $\geq 80.0\%$  or  $\geq 90.0\%$  of the heat utilized by the reactions are provided by such heat transfer. Optionally, an exothermic reaction (e.g., combustion) occurs within the catalytic oxidative coupling reactor, e.g., for preheating and/or reheating the first and/or second thermal mass segments.

[0049] The term “reaction stage” or “reactor stage” means at least one catalytic oxidative coupling reactor, and optionally including means for conducting one or more feeds thereto and/or one or more products away therefrom.

[0050] With respect to reactors, the term “zone” or “region” means a location within a reactor, e.g., a specific volume within a reactor and/or a specific volume between two reactors.

[0051] A “reaction zone” or “reactor zone” is a volume within the reactor for conducting at least one of oxidative coupling and oxydehydrogenation.

[0052] A “sorption zone” or “sorbent zone” is a volume within the reactor for sorbing and/or desorbing desired products of the oxidative coupling reaction, such as the desired  $C_2$  composition.

[0053] The term “flow-through reactor” refers to a reactor in which feed can flow through the reactor, with the oxidant and hydrocarbon reactant feeds coming into contact with the conversion catalyst and oxygen storage material as the feed flows through the reactor.

[0054] The term “tubular reactor” means an elongated, reactor vessel of substantially any cross-section, the vessel being configured to allow fluid flow into, through, and out of the vessel at least via first and second apertures, the first and second apertures being located proximate to opposed ends of the elongated reactor vessel.

[0055] The term “fixed-bed catalytic reactor” means a catalytic reactor having at least one bed of catalyst, wherein the catalyst is substantially retained within the bed.

## **II. Feed Compositions for Conversion**

[0056] The hydrocarbon conversion process can be carried out by catalytically converting a hydrocarbon reactant in the presence of oxidant. The hydrocarbon reactant and oxidant can

be components of a total feed provided to the reactor, which can further include diluent. Alkane, oxidant, and diluent can each be introduced into a reactor as one or more separate streams or as a premixed feed.

**[0057]** The feed mixture (e.g., first feed mixture in forward flow and/or second feed mixture in reverse flow) can comprise e.g., at least 10% (weight basis) of the total feed provided to the reactor. For example, the feed mixture can comprise at least 20%, or at least 30%, or at least 40%, of the total feed provided to the reactor. In certain aspects, the feed mixture comprises up to 98% of the total feed provided to the reactor. For example, the feed mixture can comprise up to 90%, or up to 80%, or up to 70% of the total feed provided to the reactor. The balance of the total feed can be diluent, for example.

**[0058]** Diluent typically comprises one or more inert materials. For example, the total feed to the reactor can be diluted with essentially inert fluid. Examples of inert fluid include, but are not limited to, steam, nitrogen, carbon dioxide or other fluids that are substantially unreactive with the hydrocarbon in the feed mixture. When diluted, the diluent can provide from 5% (weight basis) wt. % to 90% of the total feed to the reactor, or from 10% to 50%. Dilution can be carried out by adding diluent to one or more of the hydrocarbon reactant (e.g., to the alkane component), the oxidant, or the feed mixture. Examples of the alkane component of the first and/or second hydrocarbon reactant include C<sub>1</sub> to C<sub>5</sub> linear, iso, and cyclo alkanes. Specific examples include methane, ethane, propane, butane and pentane. Particular examples include methane, ethane and propane, with methane being a preferred component.

**[0059]** The oxidant typically comprises one or more fluids which yield oxygen under the specified hydrocarbon conversion conditions. Typically, the oxidant includes one or more of molecular oxygen (O<sub>2</sub>), O<sub>2</sub><sup>-</sup>, O<sub>2</sub><sup>=</sup>, ionized oxygen atoms, nitrogen oxides such as N<sub>2</sub>O, etc. Oxidant is typically in the vapor phase at the specified hydrocarbon conversion conditions, but this is not required, and in certain aspects liquid and/or solid oxidant can be used. The oxidant can comprise O<sub>2</sub>, e.g., ≥ 90% O<sub>2</sub> (molar basis, per mole of oxidant), such as, ≥ 99%. For example, the oxidant can comprise O<sub>2</sub> in air, or O<sub>2</sub> obtained or derived from air, e.g., by separation. The oxidant can comprise (or consist essentially of, or consist of) air. When the oxidant comprises O<sub>2</sub> in air, the total feed generally comprises at least a portion of the air's molecular nitrogen as diluent. In other words, when the oxidant comprises molecular oxygen in air, other gasses in the air, such as molecular nitrogen, are considered to be diluent, and are not considered to be part of the oxidant.

[0060] Alkane and oxidant are typically provided to the reactor at a mole ratio of alkane to oxidant of  $\geq 2:1$  (e.g., total molar alkane content of feed to reactor : total molar oxygen content of feed to reactor of  $\geq 2:1$ ), e.g.,  $\geq 4:1$ . For example, the alkane and oxidant are provided to the reactor at a mole ratio of alkane to oxidant of about 2:1 to about 50:1, alternatively at a mole ratio of about 2:1 to about 20:1. For example, the first and/or second mixture can have an alkane : molecular oxygen molar ratio of at least about 2:1, such as in the range of about 2:1 to about 50:1, or about 2:1 to about 20:1.

[0061] The oxidant can comprise  $\geq 90.0\%$  O<sub>2</sub> (molar basis, per mole of oxidant), e.g.,  $\geq 99.0\%$  O<sub>2</sub>. The oxidant can comprise (or consist essentially of, or consist of) air. Typically the oxidant comprises O<sub>2</sub> in air, or O<sub>2</sub> obtained or derived from air, e.g., by separation. Nitrogen in air, or obtained or derived from air, can be utilized as a feed mixture diluent. Optionally, the first and/or second feed mixture comprises alkane and air (such as methane and air), e.g., mixtures having an alkane-air mixture having an alkane : molecular oxygen molar ratio of at least about 2:1, e.g.,  $\geq 4:1$ , such as in the range of about 2:1 to about 50:1, or about 2:1 to about 20:1.

[0062] The oxidant can comprise O<sub>2</sub> in air or obtained from air. The hydrocarbon reactant can comprise  $\geq 80\%$  (molar basis) methane; and (iii) the catalytic hydrocarbon conversion is carried out at a methane : O<sub>2</sub> molar ratio of  $\geq 2:1$ , such as from 2:1 to 50:1; or  $\geq 3:1$ , such as from 3:1 to 50:1; or  $\geq 4:1$ , such as from 4:1 to 50:1.

### **III. Oxidative Coupling Catalysts and Oxydehydrogenation Catalysts**

[0063] Catalysts useful in carrying out the present reactions can be any hydrocarbon conversion catalyst effective in converting alkane (e.g., C<sub>5</sub>-alkane) in the hydrocarbon reactant to olefin (e.g. C<sub>2+</sub> olefin) through at least one of an oxidative coupling reaction and an oxydehydrogenation reaction. At least a portion of one or more of the thermal masses of the reactor comprises the catalyst. For example, the catalyst (and/or components thereof) can be arranged at one or more surfaces of the thermal mass, over which the feed components (heating fluid and hydrocarbon reactant) pass.

[0064] Particularly useful hydrocarbon conversion catalysts include oxydehydrogenation catalysts and/or oxidative coupling catalysts, such as metal oxide hydrocarbon conversion catalysts useful in oxydehydrogenation and oxidative coupling reactions. The metal oxide catalysts also include mixed metal oxide catalysts, meaning that there may be more than one metal element in the oxide catalyst. Particularly useful metal oxide catalysts are metal oxide

catalysts effective in catalytically converting alkane (e.g., methane) to C<sub>2+</sub> olefin (e.g., ethylene).

[0065] An effective metal oxide catalyst can include at least one base metal of IUPAC Group 2, Group 3, Group 7, Group 8, Group 9, Group 14, Group 15 and the lanthanide series of metals. The metal oxide catalyst can additionally include at least one Group 1 metal. Examples of each these metals are shown in the PERIODIC CHART OF THE ELEMENTS, The Merck Index, 12<sup>th</sup> Ed., Merck & Co., Inc., 1996 (“Periodic Table”).

[0066] Examples of Group 1 metals include Li, Na, K, Rb, Cs and Fr. Li, Na, K, Rb and Cs represent more common Group 1 metals.

[0067] Examples of Group 2 metals include Be, Mg, Ca, Sr, Ba and Ra. Mg, Ca, Sr and Ba are more common Group 2 metals.

[0068] Examples of Group 3 metals include Sc, Y, La and Ac. La is an example of a particularly common Group 3 metal.

[0069] Examples of Group 7 metals include Mn and Re. Mn is an example of a particularly common Group 7 metal.

[0070] Examples of Group 8 metals include Fe, Ru and Os. Fe is an example of particularly common Group 8 metal.

[0071] Examples of Group 9 metals include Co, Rh and Ir. Co is an example of particularly common Group 9 metal.

[0072] Examples of Group 14 metals include Sn and Pb. Pb is an example of a particularly common Group 14 metal.

[0073] An example of a Group 15 metal includes Bi.

[0074] Examples of the lanthanide series of metals include Ce, Pr, Nd, Sm, Eu, Gd, Tb, Dy, Ho, Er, Tm, Yb and Lu. Sm, Gd, Ho, and Yb are more common lanthanide metals.

[0075] Specific examples of oxidative coupling catalysts include those listed in U.S. Patent No. 6,096,934. Such catalysts include lithium supported on magnesium oxide where the lithium is present in either the hydroxide or oxide form; bismuth supported on calcium oxide where the bismuth is present in either the hydroxide or oxide form; lithium supported on calcium oxide where the lithium is present in either the hydroxide or oxide form; cerium supported on magnesium oxide where the cerium is present in either the hydroxide or oxide form; nickel and lanthanum supported on magnesium oxide where the lanthanum is present in either the hydroxide or oxide form and the nickel is present in the metallic form; and lithium supported on lanthanum oxide where the lithium is present in either the hydroxide or oxide



form; or any other metal or metal oxide or hydroxide catalyst promoted with a Group 1, 2, or lanthanide series element present in an oxide or hydroxide form.

[0076] U.S. Patent No. 5,245,124 discloses an order of oxidative coupling catalysts first reported by Y.A. Amenomiya et al. in "Conversion of Methane by Oxidative Coupling," report to CANMET, Energy, Mines and Resources, Ottawa, Canada. The rating of catalysts is listed as follows:  $\text{Li/Sm}_2\text{O}_3 > \text{Na/CaO} > \text{K/CaO} > \text{LaAl}_2\text{O}_3 > \text{Sm}_2\text{O}_3 > \text{Li/CaO} > \text{PbO} > \text{Bi}_2\text{O}_3 > \text{Ho}_2\text{O}_3 > \text{Gd}_2\text{O}_3 > \text{Li/MgO} > \text{Li/CaO} \sim \text{Yb}_2\text{O}_3 > \text{Y}_2\text{O}_3\text{Na/MgO} \sim \text{CaO} > \text{MgO}$ . Additives to the catalysts include Ba, Li, Sr, Pb, K, Mg, Ca, Na, and Sb.

[0077] Perovskites of the structure  $\text{A}_2\text{B}_2\text{C}_3\text{O}_{10}$  are also useful as catalysts for the oxidative coupling and/or oxydehydrogenation of lower alkane to heavier hydrocarbons. A is alkali metal; B is lanthanum or a lanthanide element, for example, cerium, neodymium, samarium, praseodymium, gadolinium or dysprosium; and C is titanium. A particular example is shown in U.S. Patent No. 5,026,945, in which the perovskite is represented by the formula  $\text{A}_x\text{Ln}_y\text{Ti}_z\text{O}_{10}$ , wherein A is one or more alkali metal; Ln is one or more of lanthanum, cerium, neodymium, samarium, praseodymium, gadolinium and dysprosium; x is about 2; y is about 2; and z is about 3.

[0078] The catalysts can be incorporated with at least one thermal mass of the reactor. In such configurations, the hydrocarbon reactant flowing through the flow-through reactor and oxygen released from the oxygen storage material of the reactor are contacted in the presence of the catalyst to convert alkane in the hydrocarbon reactant to the specified  $\text{C}_2$  composition. The catalyst is preferably arranged along with one or more of the thermal masses of the reactor to transfer heat to the hydrocarbon reactant as it passes through the flow-through reactor. For example, the catalyst (and/or components thereof) can be arranged at one or more surfaces of the thermal masses adjacent to or mixed with the oxygen storage material, and in a manner in which hydrocarbon reactant passes over or across the catalyst and released oxygen.

#### **IV. Catalytic Reactors and Reaction Conditions**

[0079] The reaction for converting alkane to  $\text{C}_{2+}$  unsaturated hydrocarbon is carried out in at least one reactor. Several reactors may be combined to become a single entity that is also identified as a reactor, in that individual and combined entities may be characterized as an apparatus useful for the specified chemical conversion. Main conversion reactions in the reaction zone section of the reactor, when the feed to the reactor is comprised of methane and oxygen, are the exothermic reactions to  $\text{C}_2$  products:

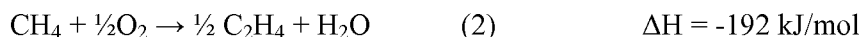

and optionally combustion, which consumes more oxygen and generates more heat:



It has been found that by regulating the relative amount of hydrocarbon reactant and oxidant, reactions (1) and particularly (2) can be favored over reactions (3), and (4), and over reactions which combust one or more of the desired products. Such undesirable combustion reactions include  $\text{C}_2\text{H}_x + \text{O}_2 \rightarrow \text{CO}_2 + \text{H}_2\text{O}$ , such as  $\text{C}_2\text{H}_4 + 3\text{O}_2 \rightarrow 2\text{CO}_2 + 2\text{H}_2\text{O}$  (-1412 kJ/mol) and  $\text{C}_2\text{H}_6 + \frac{7}{2}\text{O}_2 \rightarrow 2\text{CO}_2 + 3\text{H}_2\text{O}$  (-1517 kJ/mol).

**[0080]** The hydrocarbon conversion processes, i.e., oxidative coupling reactions and oxydehydrogenation reactions, are carried out in the presence of one or more conversion catalysts located in the reactor at temperatures and pressures effective for converting alkane to  $\text{C}_{2+}$  olefins. For example, the hydrocarbon conversion process is particularly efficient when carried out at reaction zone temperatures of from 550°C to 1100°C. Alternatively, the hydrocarbon conversion process is particularly efficient at reaction zone temperatures of from 650°C to 900°C, or at temperatures of from 675°C to 825°C.

**[0081]** Operating pressures may include a pressure of at least atmospheric pressure (zero pressure, gauge), such as  $\geq 4$  pounds per square inch gauge (psig) (28 kilo Pascals gauge (kPag)), or  $\geq 15$  psig (103 kPag), or  $\geq 36$  psig (248 kPag), or  $\geq 44$  psig (303 kPag), or  $\geq 103$  psig (710 kPag), but may be  $\leq 300$  psig (2068 kPag), or  $\leq 163$  psig (1124 kPag), or  $\leq 150$  psig (1034 kPag).

**[0082]** As may be appreciated, these different pressures and temperatures may be utilized together to form different combinations depending on the specific configuration of equipment.

**[0083]** Residence times in the reactor may be  $\leq 20$  seconds,  $\leq 10$  seconds and preferably  $\leq 5$  seconds or in the range of 0.01 seconds to 20 seconds or in the range of from 0.5 seconds to 10 seconds. For a reverse-flow reactor, the process may operate at cycle times  $\geq 0.1$  seconds, e.g.,  $\geq 0.5$  seconds, such as in the range of 10 seconds to 240 seconds, in the range of 10 seconds to 120 seconds, in the range of 20 seconds to 60 seconds, or in the range of 20 seconds to 40 seconds. The term "cycle time" means the time from a first interval to the next first interval, including (i) intervening second, third, and/or fourth intervals and (ii) any dead-time between any pair of intervals. Surprisingly, it has been found that a certain range of

cycle time is particularly beneficial in aspects where (i) C<sub>2</sub> selective sorbent and/or (ii) olefin-selective sorbent is located within a reverse-flow reactor and (iii) sorption and/or desorption is carried out under kinetic conditions. In those aspects, it is typically beneficial to operate at a cycle time in the range of 0.1 seconds to 60 seconds such as in the range of 0.5 seconds to 40 seconds, or 0.5 seconds to 20 seconds. Doing so is observed to decrease the amount of methane in the desorbed C<sub>2</sub> composition.

**[0084]** Any reactor suitable for carrying out oxidative coupling reactions and oxydehydrogenation reactions can be used, e.g., fixed-bed catalytic reactors. Examples of fixed-bed catalytic reactors include fixed-bed tubular reactors.

**[0085]** Reverse-flow catalytic reactors can be used, including one or more conventional reverse-flow reactors. Conventional reverse-flow reactors are typically used for converting or cracking reactions, and to execute cyclic, high temperature chemistry, such as those reactions that may be performed at temperatures higher than that which can suitably be performed in conventional steam crackers. Such reactors are described in U.S. Patent Nos. 7,943,808, 7,491,250, 7,846,401, and 7,815,873. It has been found that when adapted as specified, reverse-flow reactors are suitable for use in certain aspects of the invention. The reactors can be physically-symmetric, e.g., about a central axis. The reactors can be adiabatic.

**[0086]** Reverse-flow catalytic reactor cycles typically are either symmetric or asymmetric. Asymmetric cycles are typically used to execute endothermic chemistry, and the desired endothermic chemistry is paired with a different chemistry that is exothermic (typically combustion) to provide heat of reaction for the endothermic reaction.

**[0087]** Regenerative, reverse-flow catalytic oxidative coupling reactors can be used to carry out the oxidative coupling and oxydehydrogenation reactions. A regenerative, reverse-flow reactor is (i) "reverse flow" in the sense that an upstream region of the reactor with respect to the average flow of the first feed mixture corresponds to the downstream region with respect to the average flow of the second feed mixture and (ii) "regenerative" in the sense that at least a portion of any heat lost (e.g., by radiation) during the e first interval is restored by heat released in the second interval (and vice versa). For example, during the first and second intervals, the reverse-flow reactor exothermically reacts the first or second mixture, as the case may be, to store heat within a defined volume (e.g., the first and/or second thermal mass). The reactors can be symmetric, asymmetric, or a combination thereof.

[0088] A variety of regenerative oxidative coupling reactors may be utilized. For example, an oxidative coupling reactor may include a housing, a plurality of flow-control means (e.g., conduits and valves), one or more insulation components (e.g., insulation bricks) and one or more process flow components (e.g., thermal mass, mixing components, etc.). The housing may be utilized to enclose an interior region and has one or more insulation components disposed adjacent to the housing. The plurality of flow control means may include one or more conduits, one or more apertures, and one or more valves that are configured to manage the flow of one or more streams into and out of the interior region from a location external to the interior region or housing. Process flow components can be configured and/or arranged to manage the flow of fluids through the interior region, wherein the one or more process flow components may include a thermal mass having different portions with each portion having different flow passages and a wetted area. In aspects where the first and/or second mixtures are combined in a reverse-flow reactor, one or more mixer or mixer-distributors can be used for the mixing.

[0089] Regenerative reverse-flow reactors may involve multiple steps repeated in sequence to form a cycle for the process. That is, the oxidative coupling process may include two or more sequential steps. The steps can include, e.g., (i) forward-flow hydrocarbon conversion step, (ii) an optional regeneration step to heat or preheat the zones containing the thermal masses, and (iii) a reverse-flow hydrocarbon conversion step. The steps may involve passing mixtures over a solid material in fixed orientation (e.g., one or more thermal masses). As part of these steps, valves may be utilized to alternate introduction of a first feed mixture and/or a second feed mixture into the interior region of the reactor.

[0090] As an example, an optional regeneration step can be used between successive forward-flow and reverse-flow hydrocarbon conversion steps. A combustion mixture of fuel, oxidant, and/or a supplemental amount of one of these reactants, can be delivered directly to a location along the flow path within the reactor (e.g., a mixing zone). The delivered reactants in the combustion mixture then exothermically react (combust) and heat the thermal mass. According to one aspect of this invention, the combustion reaction can be carried out to heat the thermal masses before, during and/or after one or more intervals of the oxidative coupling reaction. For example, a combustion reaction can be carried out to initially heat (e.g., preheat) one or more thermal masses of the reverse-flow reactor. Combustion products can then be exhausted. Following reactor regeneration, a first feed mixture can be introduced into the reactor and exposed to the heated thermal mass and catalyst to cause heating and

oxidative coupling of the alkane and oxidant in the first feed mixture. The reaction products and/or unreacted first feed mixture can then be quenched as they flow through the reactor to halt the oxidative coupling catalytic reactions and/or oxydehydrogenation reactions and yield reaction products (e.g., contained in the first reaction mixture). The quenching can be accomplished, e.g., by transferring heat to a cooler region of the reactor, obviating the need for an external quench as in the conventional process. For example, the reactor can contain a cooler thermal mass (cooler than the reaction products) located downstream of the oxidative coupling and/or oxydehydrogenation reaction. In operation, the second thermal mass absorbs heat from the product mixture (e.g., the third mixture) during the first time interval, sufficient to (i) cool the product mixture to quench the reaction and (ii) impart heat to the second mixture (when the flow is reversed) during the second time interval (to preheat the feed).

**[0091]** The reactor may include reactor components, such as process flow components (e.g., reactor components used to manage the flow of mixtures through the reactor, one or more of the thermal masses for absorbing, storing and releasing heat, catalyst, sorbent, and/or mixing component) and insulation components (e.g., reactor components used to manage the heat transfer from the process flow within the reactor to the external surface of the reactor, such as insulation bricks, tiles or packing). The reactor components may be formed from different materials, such as refractory support materials, which can be used to support the catalyst and sorbent.

**[0092]** The heat generated from the conversion step may preferably be stored in a thermal mass material. The thermal mass material can be e.g., designed or adapted to facilitate storage and utilization of heat.

**[0093]** In certain aspects, the thermal mass is a material (e.g., a solid) that can transfer (e.g., absorb, store, and release) thermal energy over a temperature range for carrying out the reverse flow cycle, which includes the oxidative coupling reaction and any optional combustion reaction. For example, the thermal mass can be a solid material that can absorb, release, and store heat from reactants and products over a temperature range in which oxidative coupling can be carried out, including those that do so without any significant phase change. The solid material is typically one that can absorb and store heat and release the stored heat, without any significant phase change, over a temperature range in which oxidative coupling and hydrocarbon combustion are carried out. Examples of temperature ranges at which the thermal mass absorbs, stores and releases thermal energy include a range of from 50°C to 1500°C, alternatively from 100°C to 1500°C or from 200°C to 1500°C.

[0094] The thermal mass can be characterized by one or more properties. Examples of such properties include, but are not limited to, melting temperature, porosity, bulk density, thermal conductivity, thermal expansion and thermal capacity.

[0095] Melting temperatures (melting points) are reflective of the ability of the thermal mass to withstand combustion and oxidative coupling temperatures without chemical change and/or physical destruction. Thermal masses having higher melting points are preferred according to this invention. For example, the melting point of the thermal mass can be at least 1200°C, or at least 1500°C.

[0096] Porosity is a measure of the effective open pore space in the thermal mass into which heat and gasses can penetrate and eventually degrade the structure. The porosity of a thermal mass can be expressed as the average percentage of open pore space in the overall refractory volume. As an example, the thermal masses utilized in certain aspects can have a porosity of not greater than 50%, or not greater than 40%, or not greater than 30%. The porosity can be measured by an Archimedes process, e.g., mercury porosimetry.

[0097] Bulk density is a measure of the weight of a given volume of the thermal mass. Higher bulk densities, with lower porosities, can be particularly effective. As an example, the thermal masses can have a bulk density of at least 0.5 g/cm<sup>3</sup>. For example, the bulk density can be from 0.5 g/cm<sup>3</sup> to 3.5 g/cm<sup>3</sup> or from 1 g/cm<sup>3</sup> to 3 g/cm<sup>3</sup>.

[0098] Thermal conductivity is defined as the quantity of heat that will flow through a unit area in direction normal to the surface area in a defined time with a known temperature gradient under steady state conditions. Thermal conductivity represents a general heat flow characteristic of the thermal mass. Higher thermal conductivity thermal masses are preferred. For example, the thermal mass can have a thermal conductivity of from 0.1 W/mK to 50 W/mK or from 0.2 W/mK to 30 W/mK.

[0099] Thermal expansion of the thermal mass should not be so great such that cracking of the material occurs during operation of the reaction system. In one aspect, the thermal mass can be characterized by a thermal expansion coefficient. For example, the thermal mass can have a thermal mass coefficient of from 0.1x10<sup>-6</sup>/K to 20x10<sup>-6</sup>/K or from 0.2x10<sup>-6</sup>/K to 15x10<sup>-6</sup>/K. In this example, the thermal expansion coefficient is given as a value in a temperature range of from 25°C to 800°C.

[00100] Thermal capacity is the ability of a material to hold heat. The thermal masses can have a higher thermal capacity, but not so high as to increase the probability of cracking at

higher temperatures. For example, the thermal masses can have a thermal capacity of from  $250 \text{ Jm}^3/\text{K}$  to  $4500 \text{ Jm}^3/\text{K}$  or from  $500 \text{ Jm}^3/\text{K}$  to  $3000 \text{ Jm}^3/\text{K}$ .

**[00101]** Checker bricks, tiles, and monoliths may be used as to form the thermal mass components within the reactor. Such materials form a network of passages that are used by the gases in each step to transit the region containing solid material. The thermal mass may be a ceramic, which may include yttria, zirconia, alumina, and/or other refractory material capable of adsorbing, storing and transferring heat, and that are effective in withstanding temperatures within the oxidative coupling reactor.

**[00102]** A thermal mass can be provided, for example, in one or more beds that are useful for carrying out a chemical reaction e.g., in a uni-flow and/or reverse-flow reactor. Refractory material can be used in the thermal mass components and/or locations of the sorption and reaction zones, and may be of substantially any form or shape, such as, but not limited at least one of spheres, beads, honeycomb materials, a tube, pipe, U-tube, fluid mixer, nozzle, extruded monolith, brick, tile, catalyst tray, reactor tray, tray component, valves, and/or other refractory components that are exposed to high temperature. Certain aspects include thermal mass material used in fabrication of at least one of a honeycomb monolith, a reactor bed, a reactor conduit, and a reactant mixer. As non-limiting examples, thermal mass materials can comprise one or more of glass or ceramic beads or spheres, metal beads or spheres, ceramics, ceramic or metal honeycomb materials, ceramic tubes, extruded monoliths, and the like, provided they are competent to maintain integrity, functionality, and withstand long term exposure to the relevant temperatures for the oxidative coupling and combustion reactions.

**[00103]** A thermal mass can include, for example, one or more conduits, channels, or passages. The term “conduit” refers to means for conducting a composition from one location to another. The term encompasses (i) elementary conducting means, such as a pipe or tube and (ii) complex means such as tortuous pathways through conducting means, e.g., pipes, tubes, valves, and reactors, that are filled with random packing. The term “passage” means a geometrically contiguous volume element that can be utilized for conveying a fluid within a reactor, regenerator, recuperator, regenerative bed, monolith, honeycomb, etc. The term “channel” means a plurality of passages that can be utilized together for conveying a fluid within the reactor, regenerator, recuperator, regenerative bed, monolith, honeycomb, etc. For example, a honeycomb monolith can comprise a single channel, the channel having

a plurality of passages or sets of passages, e.g., hundreds of thousands of passages per square meter of the honeycomb's cross-section.

**[00104]** The shape of the thermal mass is not restricted to any particular geometry. For example, the thermal mass can be elongated, and can have elliptical, cylindrical, and/or rectangular cross-sections, including combinations thereof. A plurality of thermal masses can be of the same shape and size, but this is not required.

**[00105]** Each region or zone of a thermal mass has a beginning and end represented by a plane or surface that is approximately orthogonal to net flow direction (e.g., an upstream end and a downstream end) and a region or zone has a characteristic "average zone temperature" that is an average over all locations in the zone, from the beginning of the zone to the end of the zone, and over a specified period of time. For example, the average zone temperature of a reaction zone can be determined as an average temperature from the beginning of the reaction zone to the end, which is determined over the time period reactants are flowing through the zone. To compare average zone temperatures, such as the average zone temperature of a reaction zone to a sorption zone, the average temperatures from the beginning of the zones to the end of the zones are preferably determined over comparable time periods in which fluids flow through the respective zones. Although the thermal mass can be in thermal equilibrium at a substantially constant temperature over all its locations, this is not required, and in certain aspects a thermal mass exhibits temperature profile indicating a progression or decrease in temperature across the thermal mass. This can be the case when there is heat exchange between fluid flowing through the thermal mass and the thermal mass itself. There need not be any physical manifestation within the thermal mass of the zone's beginning or end. It may simply be a mathematical construct defining region within an otherwise homogenous thermal mass. Within any zone, the thermal mass contents can be characterized in terms of volumetric wetted area ( $a_v$ ). If the zone is homogenous in contents,  $a_v$  will be constant throughout the zone. If the zone is inhomogeneous, then  $a_v$  should be taken as a volume average over the zone.

**[00106]** One or more of the thermal masses can include separate passages through reactor components to manage the flow of hydrocarbon components and or oxidant through the thermal mass. Preferably, each thermal mass includes separate passages. The separate flow passages in the thermal mass can further comprise flow barriers that effectively function as walls to lessen or prevent cross flow or mixing of fluids (e.g., reactants, oxidants, and/or products) between passages, except in the desired regions of the reactor. Each thermal mass



preferably includes multiple passages, which may preferably be in parallel flow arrangement e.g., a channeled thermal mass that is comprised of one or more honeycomb monoliths. Preferred honeycomb monoliths are structures that comprise many (e.g., a plurality, meaning more than one) gas flow passages, arranged in parallel fashion with walls serving to separate each passage. A thermal mass can include a single monolith or a plurality of monoliths. Each monolith can be formed by extruding or die pressing monolith blocks with shaped (e.g., square or hexagonal) cross-section and two- or three-dimensionally stacking, such blocks above, behind, and beside each other. Monoliths are particularly effective as thermal mass because they provide high heat transfer capacity with lessened pressure drop.

[00107] The thermal mass may include (i) a first portion comprising a first plurality of flow passages and having a first wetted area  $a_{v1}$ ; and (ii) a second portion comprising a second plurality of flow passages and having a second wetted area  $a_{v2}$ , wherein (i)  $a_{v1} \neq a_{v2}$  and (ii)  $a_{v2}$  is different from  $a_{v1}$  by at least 25%. The difference percentage for  $a_v$ , as used herein, is defined to be based on the higher of the two wetted areas. For example, if  $a_{v1} \geq a_{v2}$ , then the percent difference between  $a_{v1}$  and  $a_{v2}$  is  $100 * (a_{v1} - a_{v2}) / a_{v1}$ .

#### **V. C<sub>2</sub> Selective Sorbent**

[00108] At least a portion of one or more of the thermal masses of the flow-through reactor can optionally include a C<sub>2</sub> selective sorbent. For example, the C<sub>2</sub> selective sorbent can be included as one or more portions or sections of the thermal mass, over which the gasses pass. For example, the C<sub>2</sub> selective sorbent can be arranged at a surface of one or more sections of the thermal mass, over which reaction conversion products pass.

[00109] In an alternative optional aspect, the C<sub>2</sub> selective sorbent can be included in external arrangement with the reactor. For example, the C<sub>2</sub> selective sorbent can be included in a C<sub>2</sub> selective sorption system, configured in fluid communication with an exit aperture of the reactor for receiving at least a portion of the catalytically converted reaction mixture.

[00110] Selective removal of one or more desired C<sub>2</sub> compositions can be carried out without having to rely on cryogenic processes by using a C<sub>2</sub> selective sorbent. The C<sub>2</sub> selective sorbent is preferably configured to selectively remove or extract at least one C<sub>2</sub> compound from a gas stream as the gas stream flows past or through the C<sub>2</sub> selective sorbent.

[00111] As used herein, a sorbent is considered a generic term, which includes "absorbent" and "adsorbent." An absorbent is a material that absorbs or incorporates a substance into the body of the absorbent material, which can also be referred to as absorption. For example, an absorbent can be used to absorb or attract or remove or extract a substance from another

substance or from a mixture of substances. An adsorbent is a material that adsorbs or attracts a substance to the surface of the sorbent material, which can also be referred to as adsorption. For example, an adsorbent can be used to adsorb or attract or remove or extract a substance from another substance or from a mixture of substances.

**[00112]** The C<sub>2</sub> selective sorbent is effective in removing or selectively sorbing one or more C<sub>2</sub> compounds from a hydrocarbon-containing composition, particularly the specified C<sub>2</sub> composition. Alternatively or in addition, the sorbent can be effective in removing or selectively sorbing one or more olefin compounds from a hydrocarbon-containing composition. In particular, the sorbent can be effective in selectively sorbing or removing at least one compound selected from the group consisting of ethane, ethylene and acetylene. In some cases, the sorbent can be selective for one of ethane, ethylene and acetylene. For example, a sorbent selective for ethylene over ethane and acetylene can be used, such as one or more of the olefin-selective sorbents. Alternatively, the sorbent can be selective for two of ethane, ethylene and acetylene. Alternatively, the sorbent can be selective for each of ethane, ethylene and acetylene.

**[00113]** In cases in which a first sorbent is used to sorb at least two of ethane, ethylene and acetylene, or each of ethane, ethylene and acetylene, a second sorbent, can be used. The second sorbent typically comprises at least one olefin-selective sorbent, which can be used in a subsequent step to separate one of the C<sub>2</sub> compounds sorbed by the first sorbent. For example, in a first step a sorbent selective for selectively separating ethane and ethylene from methane can be used (a C<sub>2</sub> selective sorbent), followed by a second sorption step in which a sorbent selective for separating ethylene can be used (an olefin-selective sorbent).

**[00114]** C<sub>2</sub> selective sorbents typically comprise at least one solid composition that is effective in selectively removing at least one C<sub>2</sub> component from a gas stream containing one or more C<sub>2</sub> compositions as the gas stream passes across or through the sorbent. Such solid compositions can include molecular sieve, e.g., one or more (i) ordered mesoporous material, (ii) ordered microporous material, (iii) zeolite, aluminophosphate, etc. The C<sub>2</sub> selective sorbent typically has a surface area of  $\geq 50$  m<sup>2</sup>/g, e.g.,  $\geq 100$  m<sup>2</sup>/g. The particular type of sorbent to be used can depend on the particular nature of the gases to be separated.

**[00115]** A kinetic separation separates by differences in diffusion and/or sorption rates through the sorbent; the differences in diffusion rates may be caused by chemoselectivity, shape selectivity or a combination of both. Kinetic separations differ from thermodynamic separations. In a thermodynamic separation, sufficient time is allowed for the gases to

equilibrate with the sorbent. However, in a kinetic separation, equilibrium is not achieved (e.g., by operating at higher rates per volume of sorbent, or by shortening the bed). Moreover, kinetic adsorbents discriminate amongst species by significant differences in the speed of diffusion and /or adsorption of ethylene compared to ethane, regardless of the respective species' equilibrium capacities/selectivities. For example, in a situation in which ethylene is the desired sorbate, a sorbent can be used that is particularly selective for ethylene at a pre-determined temperature. In certain aspects, at least one sorbent is used which is selective for removing ethylene from a gas stream under kinetic sorption conditions at a temperature region within or below the desired temperature range of the oxidative coupling reaction.

**[00116]** In certain aspects, the adsorbent for removing at least one of the C<sub>2</sub> compositions is comprised of a C<sub>2</sub> selective sorbent having a selectivity for sorbing the desired C<sub>2</sub> composition over sorbing of methane that is greater than 5. Alternatively, the adsorbent for removing at least one of the C<sub>2</sub> compositions is comprised of a C<sub>2</sub> selective adsorption material having an adsorptive loading ratio for the desired C<sub>2</sub> composition over methane of at least 10, or at least 15, or at least 20. Examples of such materials include zeolitic imidazolate framework materials, such as ZIF-7, ZIF-9 and ZIF-1 as described in greater detail in U.S. Patent No. 8,192,709.

**[00117]** The adsorptive loading ratio is a property for a specific adsorbate-adsorbent pair, at given conditions of pressure and temperature. This ratio is defined herein as a unitless quantity that is equal to the adsorption loading (in mmole/g) for the first component divided by the adsorption loading (in mmole/g) for the second component for a specific adsorbent material at a specific pressure and temperature. The adsorption loading for the desired C<sub>2</sub> composition on a particular adsorbent can be determined as described in U.S. Patent No. 8,192,709, which is incorporated herein by reference.

**[00118]** In certain aspects, the C<sub>2</sub> selective sorbent has a C<sub>2</sub> : methane selectivity > 1. For example, the C<sub>2</sub> selective sorbent can retain > 50% [ethylene + ethane] and < 50% methane; such as a C<sub>2</sub> : methane selectivity > 5 (i.e., retains > 83% [ethylene + ethane]); or a C<sub>2</sub> : methane selectivity > 99 (i.e., retains > 99 % ethylene + ethane); or a C<sub>2</sub> : methane selectivity > 999 (i.e., retains > 99.9 % [ethylene + ethane]); or a C<sub>2</sub> : methane selectivity > 9999 (i.e., retains > 99.99 % [ethylene + ethane]).

**[00119]** The C<sub>2</sub> selective sorbent can be an olefin-selective sorbent, e.g., a sorbent having an ethylene : ethane selectivity > 1 (i.e., retains > 50% ethylene, < 50% ethane). For

example, the C<sub>2</sub> selective sorbent can have an ethylene : ethane selectivity > 5 (i.e., retains > 83% ethylene); such as an ethylene : ethane selectivity > 99 (i.e., retains > 99 % ethylene); or > 999 (i.e., retains > 99.9 % ethylene); or an ethylene : ethane selectivity > 9999 (i.e., retains > 99.99 % ethylene).

**[00120]** Olefin-selective sorbents include porous materials having a high surface area, which have been treated with transition metal species capable of  $\pi$ -complexation with olefins. In particular, the double bond of the olefin can form  $\pi$ -complexes with certain transition metals, bringing about a difference in adsorption affinity between olefin and paraffin compositions. The  $\pi$ -complex is formed by the donation of  $\pi$ -electrons of the olefin to the empty  $\sigma$ -orbital of a transition metal and the back-donation of  $d$ - electrons of the transition metal to the  $\pi^*$ -orbitals of the olefin. Optionally, the olefin-selective sorbents have an electron affinity  $\geq 1.0$  eV, e.g.,  $\geq 5.0$  eV, such as  $\geq 7.0$  eV. Metals satisfying one or both of these criteria are those from groups IA through VIIIA, IB and IIB on the periodic table and their combinations. These metals may be extra-framework (e.g., ion exchanged or as metal clusters) or may be part of the framework of the adsorbent (by isomorphic substitution).

**[00121]** Group 9 transition metals are examples of transition metals that have a relatively high degree of  $\pi$ -complexation with olefins. Specific examples of Group 9 transition metals include copper and silver, particularly in their salt form. Such sorbents are described in U.S. Patent No. 4,917,711, which describes the use of supports such as zeolite 4A, zeolite X, zeolite Y, alumina and silica, each treated with a copper salt, to selectively remove carbon monoxide and/or olefins from a gaseous mixture containing saturated hydrocarbons (i.e. paraffins) such as ethane and propane.

**[00122]** In certain aspects, the olefin-selective sorbent has shape-selectivity. For example, the olefin-selective sorbent can comprise molecular sieve (e.g., as a substrate material), the molecular sieve having an average pore size that selectively excludes ethane from entering the pores of the sorbent, but allows ethylene to enter. Certain olefin-selective sorbents have an average pore size of not greater than 4.4 angstroms, or not greater than 4.3 angstroms, or not greater than 4.2 angstroms.

**[00123]** In particular aspects, the olefin-selective sorbent comprises a small pore molecular sieve, e.g., a small pore molecular sieve having at least one set of pores of substantially uniform size extending through the molecular sieve, wherein geometric mean of the cross-sectional dimensions of each of the pores is less than or equal to 4.4 Å. Suitable molecular sieves comprise zeolites, silico-alumino-phosphates (SAPOs), alumino-phosphates (AIPOs),

metal organic frameworks (MOFs), zeolite imidazoline frameworks (ZIFs) and polyaromatic frameworks (PAFs). Examples of suitable molecular sieves include materials having the framework types CHA, WEN, ABW, PHI, IHO, GIS, LOV, MON, AEI, POU, ATV, MFS, DDR, ATN, CHI, FER, LTA, LEV, ROG, DAC, ERI and ATT (see “Atlas of Zeolite Framework Types”, eds. Ch. Baerlocher, L.B. McCusker, D.H. Olson, Elsevier, Sixth Revised Edition, 2007, which is hereby incorporated by reference). For example, ATT framework type molecular sieves have two sets pores, each defined by 8-ring channels, extending through the molecular sieve, wherein the pores of one set having cross-sectional dimensions of 4.2 Å x 4.6 Å (geometric mean 4.4 Å) and the pores of the other set having cross-sectional dimensions of 3.8 Å x 3.8 Å (geometric mean 3.8 Å). Thus, the geometric mean of the cross-sectional dimensions of all the pores defined by these 8-ring channels in ATT material is less than or equal to 4.4 Å.

**[00124]** An example of a sorbent useful sorbents is provided in U.S. Patent Nos. 6,867,166 and 6,423,881, which describe the use of copper salts and silver compounds supported alternatively on silica, alumina, MCM-41 zeolite, 4A zeolite, carbon molecular sieves, polymers such as Amerberlyst-35 resin, and alumina. The silver and copper supported sorbents are effective in selectively sorbing olefins from gaseous mixtures containing olefins and paraffins. Both kinetic and thermodynamic separation behavior is disclosed.

**[00125]** Clay based sorbents can also be used. Examples are described by Choudary et al. in the *Ind. Eng. Chem. Res.* 2002, v 41, p. 2728. As one example, Ag<sup>+</sup> impregnated clay sorbents are selective for olefin uptake from a gaseous olefin/paraffin mixture. The sorbent is evaluated for ethylene separation from ethane, with over 85% recovery and at over 99% purity.

**[00126]** Another useful sorbent is described in *Chemical Engineering Research and Design*, 2006, 84(A5) p. 350, by Van Miltenburg et al., in which Cu<sup>+</sup> was used to modify Faujasite zeolites. The modified zeolites are useful sorbents for the separation of ethylene from ethylene/ethane mixtures. The use of similarly modified Faujasite zeolites in a highly selective PSA process that separates carbon monoxide and/or olefins from a mixture that also contained paraffins is also reported in U.S. Patent No. 4,717,398 assigned to BP.

**[00127]** Copper modified 4 A zeolites, as described in U.S. Patent Nos. 5,744,687; 6,200,366 and 5,365,011 assigned to BOC, are used to separate ethylene and propylene from ethane and propane respectively. Zeolites such as zeolite 5A and zeolite 13X are also used in the formation of copper modified sorbents.

[00128] Aluminophosphates, such as described in U.S. Patent No. 6,293,999 assigned to UOP, are used to separate propylene from propane. The aluminophosphate can be a small pore molecular sieve, such as "AIPO-14". Analogous zeolite sorbents can also be used in the invention.

[00129] Metal organic frameworks are also useful in selectively separating olefin from gas mixtures, with Fe-organic frameworks being particularly useful. For example, a metal-organic framework having a redox-active metal center (e.g., Fe<sub>2</sub>(dobdc)), such as described in U.S. Patent Publication No. 2013/0053585, is effective in separating olefin/paraffin mixtures such as ethylene/ethane and propylene/propane.

## **VI. C<sub>2</sub> Selective Sorption Process and System**

[00130] The C<sub>2</sub> selective sorbent has an ultimate capacity for sorbing the sorbate (e.g., the C<sub>2</sub> composition) from the reaction mixture produced by the oxidative coupling reactions and/or oxydehydrogenation reactions. Exposing the reaction mixture to at least one C<sub>2</sub> selective sorbent results in the selective sorption of at least a portion of the reaction mixture's C<sub>2</sub> composition, producing a C<sub>2</sub> lean mixture.

[00131] During the sorption process, the appearance of an increased amount of the C<sub>2</sub> composition in the C<sub>2</sub> lean mixture can be an indication that the C<sub>2</sub> selective sorbent is approaching the ultimate capacity. The appearance of an increased amount of the C<sub>2</sub> composition in the C<sub>2</sub> lean mixture can also be referred as "break-through." At a predetermined time of break-through, the passing of the reaction mixture to the C<sub>2</sub> selective sorbent can be lessened or discontinued, and the sorbed olefin can be desorbed from the C<sub>2</sub> selective sorbent.

[00132] Typically, the C<sub>2</sub> composition is desorbed from the one C<sub>2</sub> selective sorbent in order to (i) regenerate the one C<sub>2</sub> selective sorbent (to restore capacity for sorbing the reaction mixture's C<sub>2</sub> composition) and (ii) to recover the desorbed C<sub>2</sub> composition. Conventional sorbent regeneration conditions are suitable. Desorption be carried out by a reduction in temperature, pressure or both.

[00133] Optionally, a sweep fluid can be used to assist in desorbing the C<sub>2</sub> composition. Typical sweep fluids include relatively inert liquids and vapors, especially those which are relatively easy to separate from the desorbed C<sub>2</sub> composition. Steam and/or molecular nitrogen are suitable sweep fluids. C<sub>2</sub> unsaturates can be separated from the desorbed C<sub>2</sub> composition, e.g., for storage and/or further processing, such as the polymerization of ethylene obtained from the C<sub>2</sub> composition.

**[00134]** Selective separation or sorption of the sorbate, i.e., sorption of the C<sub>2</sub> composition, is carried out at a temperature in a range below that of the oxidative coupling reaction. For example, the sorbent can be located in a sorption region or zone in which the sorption zone is downstream of the reaction zone, and the sorption zone is at an average zone temperature that is less than that of the average zone temperature within the reaction zone. As an example, the sorption zone can be at an average zone temperature of at least 50°C, or at least 100°C, or at least 200°C, or at least 400°C lower than the average zone temperature within the reaction zone. Sorption can be carried out at a temperature range of from 50°C to 400°C, such that is greater than the pressure range of the reaction zone. As a practical matter, the pressure of the sorption zone can be  $\geq$  100 psig (489 kPag), such as from 100 psig (489 kPa) to 500 psig (3447 kPag).

**[00135]** Selective separation of the C<sub>2</sub> composition, such as from the reaction mixture and/or the CO<sub>2</sub> lean reaction mixture, can be carried out at a temperature of at least 50°C less than that of the average zone temperature within the reaction zone.

**[00136]** Desorption of the sorbate can be carried out at an average sorption zone temperature lower than the average zone temperature of the reaction zone, e.g., at a temperature that is from 50°C to 400°C lower than the average zone temperature of the reaction zone, such as 100°C to 300°C lower.

**[00137]** Desorption of the sorbate can also be carried out at an average temperature greater than that used for sorption of the sorbate. For example, desorption of the sorbate can also be carried out at an average temperature of at least 4°C, or at least 5°C, or at least 6°C above that used for sorption of the sorbate. In certain aspects, desorption of the sorbate is carried out at 4°C to 200°C above that used for sorption of the sorbate.

**[00138]** In certain aspects, desorption of the sorbate can be carried out at an average pressure below that used for sorption of the sorbate. For example, desorption of the sorbate can be carried out at an average pressure of from  $> 0$  psia (0 kPa) and from 1 psia (6.9 kPa) to 485 psia (3344 kPa) below that used for sorption of the sorbate.

**[00139]** The specified sorbents can be utilized in a swing adsorption process or system. The general terms “swing adsorption process” and “swing adsorption system” as used herein shall be taken to include Pressure Swing Adsorption (“PSA”), Temperature Swing Adsorption (“TSA”), Pressure Purge Displacement Processes (“PPSA”), Rapid Cycle Pressure Swing Adsorption (“RCPSA”), Rapid Cycle Temperature Swing Adsorption (“RCTSA”), Rapid Cycle Pressure Purge Swing Adsorption (“RCPPSA”) as well as

combinations of these swing adsorption processes. Alternatively, a simulated moving-bed chromatography separation may be used. The stream to be separated is typically fed to the process in a substantially gaseous state.

[00140] The composition desorbed from a C<sub>2</sub> selective sorbent (the “desorb composition”) typically comprises < 50% (molar) methane and ≥ 50% (molar) of the sorbed C<sub>2</sub> composition, e.g., ≥ 75% such as ≥90%, or ≥95%, or ≥99%. The desorb composition from an Olefin-selective sorbent typically comprises < 50% (molar) alkane (e.g., ethane) and ≥ 50% (molar) of olefin (e.g., ethylene), such as ≥ 75%, or ≥ 90%, or ≥ 99%.

## **VII. Recovering a C<sub>2</sub> Composition Produced in a Tubular Reverse-Flow Catalytic Reactor**

[00141] Oxidative coupling and oxydehydrogenation can be effectively and efficiently carried out in reverse-flow catalytic reactors to produce reaction mixtures containing relatively high quantities of C<sub>2</sub> compositions. Removing and/or recovering the reaction mixtures’ C<sub>2</sub> composition can be carried out highly effectively and efficiently by configuring C<sub>2</sub> selective sorbent systems in particular fluid communication process flows with the reverse-flow reactor.

[00142] Typical reverse-flow catalytic reactors comprise elongated tubes having first and second ends. At least one aperture (a first aperture) is typically located proximate to the first end for providing for the flow of fluids into and out of the reactor. At least one aperture (a second aperture) is typically located proximate to the second end, for providing for the flow of fluids into and out of the reactor.

[00143] In certain aspects, the reverse-flow reactor further comprises first and second thermal masses. The first thermal mass is typically located in a first internal region of the reactor proximate to the first end. A second thermal mass is typically located in a second internal region of the reactor proximate to the second end. The first and thermal masses are capable of storing and releasing heat to the reactor and to fluids conducted into, out of, and through the reactor.

[00144] The reverse-flow reactor further comprises hydrocarbon conversion catalyst. In certain aspects, the catalyst can be located in a third internal region of the reactor, the third region being located between the first and second regions. The regions of the reverse-flow reactor are optionally non-overlapping regions. For example, ≥ 50.0 wt. % of the hydrocarbon conversion catalyst, based on total weight of the hydrocarbon conversion catalyst, can be located in a zone between the first and second regions. The first and second



regions can be separate, non-overlapping regions of the reverse-flow reactor. At least a portion of the hydrocarbon conversion catalyst can be located in and/or on one or more of the thermal masses.

**[00145]** In certain aspects, (i)  $\geq 50.0$  wt. % of the first thermal mass, based on total weight of the first thermal mass, can be located in a first region of the reverse-flow reactor, (ii)  $\geq 50.0$  wt. % of the second thermal mass, based on total weight of the second thermal mass, can be located in a second region of the reverse-flow reactor, and (iii)  $\geq 50$  wt. % of the hydrocarbon conversion catalyst, based on total of the hydrocarbon conversion catalyst, can be located in a third region of the reverse-flow reactor, the third region being located between the first and second regions.

**[00146]** The reverse-flow catalytic reactor is typically operated in “flows.” For example, a first flow (or “forward flow”) can be carried out in which a first feed mixture (e.g., a first hydrocarbon reactant and oxidant) enters the reactor proximate to the first aperture, with one or more components of the first reaction mixture exiting the reactor proximate to the second aperture. In a second flow (“reverse flow”), a second feed mixture (e.g., a second hydrocarbon reactant and oxidant) enters the reactor proximate to the second aperture, with one or more components of the second reaction mixture exiting the reactor proximate to the first aperture.

**[00147]** Flows can be established for separating (i.e., sorbing) and recovering  $C_2$  compositions from the first and second reaction mixtures. For example, the first and/or second reaction mixtures can be conducted away from the reverse-flow reactor and passed to at least one sorption stage to sorb the first and/or reaction mixture’s  $C_2$  composition using an olefin-selective sorbent. The temperature and/or pressure of the olefin-selective sorbent can be adjusted to desorb and recover the desired  $C_2$  composition.

**[00148]** As an example of a reverse-flow catalytic reactor system, a first hydrocarbon reactant and first oxidant can be provided to the reverse-flow catalytic reactor when the process is operated in the forward direction. A second hydrocarbon reactant and second oxidant can be provided to the reverse-flow reactor when the process is operated in the reverse direction. Reactant and oxidant can be mixed upstream of the reverse-flow reactor. For example, a first feed mixture can be provided to the reactor when operating in the forward direction, the first feed mixture comprising the specified first hydrocarbon and the specified oxidant. A second feed mixture can be provided to the reactor when operating in the reverse direction, the second mixture comprising a second hydrocarbon reactant and second

oxidant. The second hydrocarbon reactant can be selected from among the same compositions as those specified for the first hydrocarbon reactant. The second oxidant can be selected from among the same compositions as those specified for the first oxidant. Optionally, the first hydrocarbon reactant has substantially the same composition as the second hydrocarbon reactant and (ii) the first oxidant has substantially the same composition as the second oxidant. Optionally, the second feed mixture can be selected from among the same compositions as the first feed mixture. Optionally, the second feed mixture has substantially the same composition as the first feed mixture.

**[00149]** During a first time interval, the first feed mixture can be passed into and through the reverse-flow catalytic reactor in the forward-flow direction. The first feed mixture reacts (exothermally) in the reactor in the presence of a first hydrocarbon conversion catalyst. Heat can be transferred from the first thermal mass, which can be previously heated, to the first feed mixture (or one or more components thereof prior to mixing) to produce a heated first feed mixture. At least a portion of the heated first feed mixture's alkane is catalytically converted in the presence of at least a portion of the heated first feed mixture's oxidant and in the presence of the first hydrocarbon conversion catalyst to produce a first reaction mixture. The first reaction mixture can comprise (A) C<sub>2</sub> composition produced by the alkane conversion and (B) any unconverted first feed mixture. Heat can be transferred from the first reaction mixture to the second thermal mass, to produce a cooled first reaction mixture.

**[00150]** During a second time interval, the second feed mixture can be passed to the reverse-flow reactor in the reverse-flow direction. Heat can be transferred from the second thermal mass to the second feed mixture (or to one or more components thereof prior to mixing) to produce a heated second feed mixture. The second thermal mass can be heated before the second time interval, e.g., during the first interval, as a result of the heat transfer from the reaction mixture to the second thermal mass. At least a portion of the heated second feed mixture's alkane can be catalytically converted in the presence of at least a portion of the heated second feed mixture's alkane and a second hydrocarbon conversion catalyst to produce a second reaction mixture. The second reaction mixture can comprise (A) C<sub>2</sub> composition produced by the alkane conversion and (B) any unreacted second feed mixture. Heat can be transferred from the second reaction mixture to the first thermal mass to re-heat the first thermal mass and produce a cooled second reaction mixture.

**[00151]** The cooled first and/or second reaction mixture can be conducted away from the reverse-flow reactor to an olefin sorption system having at least one separation stage to

separate and/or recover the first and/or reaction mixture's C<sub>2</sub> composition. For example, the first and/or second reaction mixture can be conducted away from the reverse-flow reactor to at least one separation stage in fluid communication with the reverse-flow reactor. The separation stage contains at least one C<sub>2</sub> selective sorbent for sorbing at least a portion of the cooled first reaction mixture's C<sub>2</sub> composition. For example, the cooled first reaction mixture can be optionally treated to remove CO<sub>2</sub> and/or water and passed to at least one adsorber unit of a swing adsorption system to adsorb the reaction mixture's C<sub>2</sub> composition. At the adsorber unit's sorption capacity, passage of the reaction mixture to the adsorber unit of the swing adsorber system can be lessened or discontinued, and the temperature and/or pressure of the unit can be adjusted to desorb at least a portion of the sorbed C<sub>2</sub> composition, at least partially regenerating the C<sub>2</sub> selective sorbent. A sweep fluid can be optionally used to enhance desorption of the sorbed C<sub>2</sub> composition for the adsorber unit.

#### **VIII. Selective Removal of CO<sub>2</sub> and H<sub>2</sub>O**

**[00152]** Desired recovery and/or separation of a desired C<sub>2</sub> composition can be carried out through little if any reliance on cryogenic separation processes according to this invention. In certain aspects, the non-cryogenic process can be carried out by including a step of selectively removing from the reaction mixture at least a portion of the CO<sub>2</sub> produced during the alkane conversion to produce a CO<sub>2</sub> lean reaction mixture. The CO<sub>2</sub> lean reaction mixture can be comprised of at least a portion of the C<sub>2</sub> composition produced by the alkane conversion and at least a portion of the unconverted methane, with the CO<sub>2</sub> lean reaction mixture having a CO<sub>2</sub> content less than that of the reaction mixture.

**[00153]** Typically, the C<sub>2</sub> composition comprises  $\geq 90\%$  (molar basis, per mole of C<sub>2</sub> composition) of one or more of (i) ethane, (ii) ethylene, and (iii) acetylene, e.g.,  $\geq 95\%$ , such as  $\geq 99\%$ . For example, the C<sub>2</sub> composition can comprise  $\geq 90\%$  of (i) ethane and (ii) ethylene, such as  $\geq 95\%$ , or  $\geq 99\%$ . The C<sub>2</sub> composition can be one that predominantly comprises C<sub>2</sub> unsaturates, e.g.,  $\geq 50\%$  of (i) ethylene and/or (ii) acetylene, such as  $\geq 75\%$  ethylene, or  $\geq 90\%$  ethylene, or  $\geq 99\%$  ethylene, with the balance comprising ethane, e.g.,  $< 50\%$  ethane, such as  $\leq 25\%$ , or  $\leq 10\%$ , or  $\leq 1\%$  ethane. One suitable C<sub>2</sub> composition comprises 50% to 99% ethylene, with the balance comprising ethane, e.g., 75% to 99% ethylene or 90% to 99% ethylene.

**[00154]** The C<sub>2</sub> composition separated from the reaction mixture can be separated from the CO<sub>2</sub> lean reaction mixture. A CO<sub>2</sub> lean reaction mixture can comprise hydrocarbon produced from the conversion reaction, and less CO<sub>2</sub> than the reaction mixture itself. The CO<sub>2</sub> lean

reaction mixture can have a CO<sub>2</sub> content of not greater than 5 mol %, or of not greater than 3 mol %, based on total volume of the CO<sub>2</sub> lean reaction mixture.

**[00155]** Selective removal or separation of the CO<sub>2</sub> from the reaction mixture can be carried out by any suitable process. For example, separation can be carried out by one or more of distillation, membrane separation and sorption using an appropriate sorbent, where the term “sorbent” means a material that sorbs or attracts a substance from another substance. Sorption can be by absorption (using chemical or physical solvents) or adsorption. For example, selective separation of the CO<sub>2</sub> from the reaction mixture can be carried out by reaction with an appropriate base. Amine-based chemical treatments can be used. Particular examples of amine-based treatments include alkanolamines. Alkanolamines include primary amines such as monoethanol amine and diglycolamine; secondary amines such as diethanol amine and diisopropyl amine; and tertiary amines such as triethanol amine and methyldiethanol amine.

**[00156]** Although amine-based solvents can be considered chemical solvents, physical-type solvents can also be used to selectively separate CO<sub>2</sub> from the reaction mixture by physical absorption. Physical-type absorbents allow a gas to permeate a solid or liquid under one set of conditions, and desorb under others. The rate of absorption or desorption is temperature and pressure dependent. Smaller differences in conditions can require less energy, although more absorbent may be needed to capture CO<sub>2</sub> at an equivalent rate.

**[00157]** Absorption in physical solvent systems can occur at high partial pressure of CO<sub>2</sub> and low temperatures. The solvents can then be regenerated by heating, pressure reduction, or a combination of both.

**[00158]** Other methods of CO<sub>2</sub> removal may include physical solvent scrubbing of CO<sub>2</sub> with a glycol-based solvent. Methanol and glycerol are other examples of physical solvents that can be used for removing CO<sub>2</sub>.

**[00159]** CO<sub>2</sub> can also be selectively separated from the reaction mixture by physical adsorption. Physical adsorption relies on the affinity of CO<sub>2</sub> to the surface of a material under certain conditions without forming a chemical bond. Adsorbents can separate CO<sub>2</sub> from a stream by preferentially attracting it to the material surface at high pressures through weak interactions such as van der Waals forces. During capture, the chemical potential of the adsorbed CO<sub>2</sub> is lower than the chemical potential of CO<sub>2</sub> in the gas mixture.

**[00160]** Regenerable adsorbents can also be used to separate the CO<sub>2</sub>. Regenerable adsorbents have the ability to reverse the chemical potential of the adsorbed phase upon

changing the conditions to remove the CO<sub>2</sub>. This can be accomplished by changing pressure and/or temperature conditions or stripping with an easily separable gas such as steam. Swing adsorption systems (pressure and/or temperature swing absorption) can be used.

[00161] Examples of adsorbents useful for selectively separating CO<sub>2</sub> include, but are not limited to, activated carbon and molecular sieves. Examples of molecular sieves include, but are not limited to, zeolites and hydrotalcites.

[00162] Membrane systems can also be used to separate CO<sub>2</sub>. Membrane systems include relatively thin barriers that allow selective permeation of certain gases, allowing one component in a gas stream to pass through faster than the others. Examples of membranes that can be used to selectively adsorb CO<sub>2</sub> from the reaction mixture include polymeric membranes, inorganic microporous membranes, and palladium membranes. Polymeric membranes include cellulose acetate, polysulfone, and polyimide. Inorganic membranes can be particularly beneficial for withstanding high temperatures. Membrane separation combined with solvent separation can be highly effective.

[00163] Water removal can be accomplished by any suitable means. For example, water can be relatively easily removed by condensing the water, while leaving lower boiling point components of the reaction mixture in vapor phase. Examples of such processes include flash separation and/or distillation.

## **IX. Examples**

### **Example 1 (with reference to FIG. 1)**

[00164] FIG. 1 depicts a generalized system for selectively removing the specified C<sub>2</sub> composition according to certain aspects of the invention. Hydrocarbon conversion reactor 100 contains the specified hydrocarbon conversion catalyst, namely one having oxidative coupling and/or oxydehydrogenation functionality. A hydrocarbon reactant containing methane (CH<sub>4</sub>) is introduced into the hydrocarbon conversion reactor 100 via a line 102, and oxidant containing molecular oxygen (O<sub>2</sub>) is introduced via a line 104. At least a portion of the methane is catalytically converted to a reaction mixture comprising (i) a C<sub>2+</sub> composition, including at least ethane and ethylene, and (ii) CO<sub>2</sub> and/or water, and (iii) any unreacted methane. The reaction mixture exits the reactor via a line 106 and is sent to a first separation unit 108 for removing at least a portion of the CO<sub>2</sub> and water. A CO<sub>2</sub> lean and water lean stream exits the first separation unit via a line 110 and is sent to a second unit 112. CO<sub>2</sub> and water removed from the reaction mixture in the first separation unit 108 can be later

conducted away the first separation unit 108. Typically, the CO<sub>2</sub> is reacted, with the reaction products being conducted away from stage 108.

[00165] At least a portion of the C<sub>2</sub> composition (e.g., ethane and/or ethylene) present in the CO<sub>2</sub> lean and water lean stream is selectively adsorbed by at least one C<sub>2</sub> selective sorbent in second separation unit 112, producing a methane rich stream 116. In addition, a purge stream 118 may be removed from unit 112. The methane rich stream is shown as being recycled via a line 116 back to the hydrocarbon conversion reactor 100 for re-processing, although at least a portion of the methane stream can be used for further processing in alternate processes. The sorbed C<sub>2</sub> composition can be desorbed by lessening or discontinuing flow of the hydrocarbon reaction mixture through line 110 to the second separation unit 112. Temperature and/or pressure of unit 112 can be adjusted to desorb at least a portion of the sorbed C<sub>2</sub> composition, and the desorbed C<sub>2</sub> composition can be recovered by way of line 114. A sweep fluid can be flowed through a line 120 to the second selective sorption unit 112 to enhance desorption and recovery of the C<sub>2</sub> composition.

**Example 2 (with reference to FIG. 2)**

[00166] FIG. 2 depicts another generalized system for selectively removing a C<sub>2</sub> composition according to certain aspects of the invention. Hydrocarbon conversion reactor 200 contains catalyst the specified hydrocarbon conversion catalyst. A hydrocarbon reactant containing methane (CH<sub>4</sub>) is introduced into the hydrocarbon conversion reactor 200 via a line 202, and oxidant containing molecular oxygen (O<sub>2</sub>) is introduced via a line 204. At least a portion of the methane is catalytically converted to a reaction mixture comprised of C<sub>2+</sub> compositions, including at least ethane and ethylene, as well as CO<sub>2</sub> and water, and further includes any unreacted methane. The reaction mixture exits the reactor via a line 206, and is sent to a CO<sub>2</sub> separation unit 212 to selectively remove at least a portion of the CO<sub>2</sub> via a line 211 (typically in the form of products of a CO<sub>2</sub> conversion reaction). A CO<sub>2</sub> lean stream exits the CO<sub>2</sub> separation unit via a line 213 and is sent to a water separation unit 208 to selectively remove at least a portion of the water via a line 209. A CO<sub>2</sub> lean and water lean stream exits the water separation unit 208 via a line 210 and is sent to an optional first compressor 231. The compressor can be used to boost the pressure of the CO<sub>2</sub> lean and water lean stream in line 210 to a pressure of  $\geq 100$  psig (489 kPag) if needed, with the pressurized CO<sub>2</sub> lean and water lean stream being passed by a line 232 to a C<sub>2</sub> selective sorption system S.

[00167] The C<sub>2</sub> selective sorption system S in FIG. 2 is a representative aspect of a swing sorption system, comprising sorbent units A1 and A2 containing C<sub>2</sub> selective sorbent for sorbing and recovering C<sub>2</sub> compositions. Units A3 and A4 contain olefin-selective sorbent. Sorbent units A1 and A3 are shown in sorption mode, with valves V1, V3, V6, V8, V9 and V12 being in the open position. The sorbent units A2 and A4 are shown in desorption mode, with valves V2, V4, V5, V7, V10 and V11 being in the closed position. In this desorption mode, no fluid is flowed through line 226, or from A1 to line 218. Flow through all other lines is as follows.

[00168] As shown in FIG. 2, the CO<sub>2</sub> lean and water lean stream is sent to sorbent unit A1, which is at a temperature lower than the hydrocarbon conversion reactor 200 and  $\geq 50^{\circ}\text{C}$ . As the stream passes through the sorbent unit A1, C<sub>2</sub> composition (e.g., ethane and ethylene) is adsorbed by the sorbent. Unreacted methane and other reaction components such as CO flow through the sorbent unit A1, exiting by way of open valve V3 and line 224 as a methane rich stream. In the mode of operation shown in FIG. 2, the methane rich stream is sent to a compressor 227, which may be optional. For example, only one of compressor 231 and compressor 227 may be utilized to maintain the desired operating pressures. However, both compressor 231 and compressor 227 can be utilized if desired.

[00169] The methane rich stream exits compressor 227 via line 228. In recycle mode, the methane rich stream can be recycled to hydrocarbon conversion reactor 200 via line 232. At times, the methane rich stream can build in CO content. In such case, the methane rich stream can be purged via a line 223 and further processed such as by flaring or further oxidation in a CO boiler.

[00170] Desorption of the C<sub>2</sub> composition (e.g., ethane and ethylene) from the sorbent is shown being carried out in sorbent unit A2 by increasing the sorbent's temperature. In this example, sweep fluid (e.g., steam) is sent to sorbent unit A2 via a line 242 and open valve V6, with the sweep fluid being at a temperature greater than the temperature at which sorption of the C<sub>2</sub> composition in the sorbent unit A2 has been carried out. The heating of the sorbent by the sweep fluid and the movement of the sweep fluid through the sorbent unit A2 causes the C<sub>2</sub> composition to desorb from the sorbent. Then the desorbed C<sub>2</sub> composition and sweep fluid are passed through open valve V8 via a line 218 and passed through sorbent unit A3 via open valve V9.

[00171] Unit A3 contains olefin-selective sorbent for sorbing ethylene from the C<sub>2</sub> composition. The sorbent is at a temperature lower than that of the hydrocarbon conversion

reactor 200 and is  $\geq 50^{\circ}\text{C}$ . Thus, as the  $\text{C}_2$  composition and sweep fluid flow through the sorbent unit A3, the ethylene is selectively sorbed and the ethane and sweep fluid exit the sorbent unit A3 via a line 222. The sweep fluid can be relatively easily condensed at non-cryogenic temperatures and separated from the ethane to recover substantially pure ethane.

[00172] In aspects shown in FIG. 2, desorption of ethylene from the sorbent is being carried out in sorbent unit A4. Desorption is facilitated by increasing the temperature of the sorbent. In this example, sweep fluid (e.g., steam) is sent to sorbent unit A4 via a line 241 and open valve V12, with the sweep fluid being at a temperature greater than the temperature at which sorption of the ethylene from the  $\text{C}_2$  composition has been previously carried out. The heating of the sorbent by the sweep fluid and the movement of the sweep fluid through the sorbent unit A4 causes the ethylene to desorb from the sorbent. Then the desorbed ethylene and sweep fluid exit the sorbent unit A4 via a line 220. The sweep fluid can be relatively easily condensed at non-cryogenic temperatures and separated from the ethylene to recover substantially pure ethylene.

**Example 3 (with reference to FIGs. 3A and 3B)**

[00173] FIGs. 3A and 3B depict aspects of a generalized reverse-flow reactor system that can be used to carry out the specified conversion reaction. Such aspects can be used as the conversion reactors 100 and 200 of FIGs. 1 and/or 2.

[00174] The reverse-flow reactor includes two regions: a first region (Region 1) and a second region (Region 2). Region 1 and Region 2 comprise a first thermal mass (M1) and a second thermal mass (M2), respectively. The thermal masses can be selected from among any of the specified thermal masses, and can be coupled together as a continuous mass or coupled in a series arrangement of mass materials. The terms first and second thermal masses are used to particularly describe the flow of heat in the reverse-flow reactor system according to regions that are heated and cooled by means of thermal mass, such that the reaction being carried out results in absorption and release of heat in a manner that is effective in continuously operating the reverse-flow reactor system.

[00175] A catalytic conversion zone (Zone C) is included in the reverse-flow reactor shown in FIGs. 3A and 3B. At least one hydrocarbon conversion catalyst is included in Zone C. At least a portion of the catalyst of the catalytic conversion Zone C can be deposited on or in the first thermal mass M1 (or a segment thereof) and/or second thermal mass M2 (or a segment thereof) of the Regions 1 and 2, e.g., in aspects where the catalytic conversion zone overlaps both Region 1 and Region 2. However, the catalyst can be completely located in



either Region 1 or Region 2, and/or in a region located between Regions 1 and 2. The specified hydrocarbon conversion catalyst can be part of or attached to the thermal mass material of Region 1, Region 2, or both. Optionally, the catalyst is located in a defined sub-region of the first and/or second thermal mass, the sub-regions being proximate to the center of the reactor as shown in FIGs. 3A and 3B.

[00176] Optionally, one or more mixer means can be used between reactor regions or zones, e.g., between  $M_1$  and C and/or between  $M_2$  and C. Doing so is observed to improve the oxidative coupling reaction. Mixer mechanisms, distributor mechanisms, reactor system internals, flow-control mechanisms, etc., for the reactor can be substantially the same as those described in U.S. Patent No. 7,943,808 and/or U.S. Patent Application Publication No. 2013/157205, for example.

[00177] In aspects shown in FIG. 3A, during a first time interval, a first feed mixture is passed to an inlet 1 of the reverse-flow reactor. The first feed mixture can comprise  $\geq 10.0$  wt. % alkane and  $\geq 2.0$  wt. % oxidant, the weight percents being based on total weight of the first feed mixture.

[00178] As shown in FIG. 3A, the first feed mixture passes proximate to the first thermal mass (e.g., is passed through or across the first thermal mass)  $M_1$  of Region 1, which has been previously heated to a predetermined temperature range suitable to convert components of the first feed mixture to the desired product. As the first feed mixture passes the first thermal mass  $M_1$ , heat is transferred from the heated first thermal mass  $M_1$  to the first feed mixture to produce a heated first feed mixture. The heated first feed mixture passes the catalytic conversion Zone C, catalytically converting, preferably by an exothermic reaction process, at least a portion of the heated first feed mixture's alkane to produce a first reaction mixture. The first reaction mixture can comprise, e.g.,  $C_{2+}$  olefin produced by the alkane conversion, and any unconverted portion of the first mixture. Heat is transferred from the first reaction mixture to the second thermal mass  $M_2$ , and at least a portion of the first reaction mixture is conducted away from the reverse flow-reactor by way of an exit 2 of the reverse-flow reactor, e.g., for separating olefin from the first reaction mixture. The movement of the reverse-flow reactor's temperature profile during the first time interval is represented by the arrows on curve TP. Flow of the first feed mixture to the inlet 1 is subsequently lessened or discontinued. A reverse flow can then be initiated, e.g., during a second time interval.

[00179] During a second time interval, illustrated in FIG. 3B, reverse flow is initiated by passing a second feed mixture through the exit 2 of the reverse-flow reactor, in reverse flow direction from that of the first feed mixture. The second feed mixture also comprises  $\geq 10.0$  wt. % alkane and  $\geq 2.0$  wt. % oxidant, the weight percents being based on total weight of the second mixture, and is obtained from the same source as the first feed mixture.

[00180] As shown in FIG. 3B, the second feed mixture passes proximate to the second thermal mass (e.g., is passed through or across the second thermal mass) M2 of Region 2. M2 has been previously heated as a result of the exothermic reaction previously carried out in the catalytic conversion zone C during the first time interval, e.g., by transferring heat from the first reaction mixture to M2. As the second feed mixture passes the second thermal mass M2, heat is transferred from the heated second thermal mass M2 to the second feed mixture to produce a heated second feed mixture. The heated second feed mixture passes the catalytic conversion zone C, catalytically converting, preferably by exothermic reaction, at least a portion of the heated second feed mixture's alkane to produce a second reaction mixture. The second reaction mixture comprises, e.g.,  $C_{2+}$  olefin produced by the specified alkane conversion, and any unconverted second feed mixture. Heat is transferred from the second reaction mixture to the first thermal mass M1, and at least a portion of the second reaction mixture is conducted away from the reverse flow-reactor by way of the inlet 1 of the reverse-flow reactor. Movement of the reverse-flow reactor's temperatures profile during the second time interval is represented by the arrows on curve TP. Flow of the second reaction mixture is subsequently lessened or discontinued. One skilled in the art will appreciate that during the second time interval (i) inlet 1 functions as an exit and (ii) exit 2 functions as an inlet.

[00181] The first and second time intervals, as generally described according to the exemplary schemes shown in FIGs. 3A and 3B, can be substantially non-overlapping intervals. Each of the first and second time intervals can be, independently, an interval having a duration in the range of from about 0.5 seconds to about 15 seconds. The interval between the first and second time intervals (the "dead-time", which represents the interval of time it takes to reverse flow of the feed mixtures) is preferably as short as possible so that the reverse flow cycle can be as rapid as possible. From a practical standpoint, the dead-time should be, e.g.,  $\leq$  than 0.5 seconds, such as in a range of from about 0.01 seconds to about 0.5 seconds. Upon completion of the second time interval, the intervals can be repeated. That is, the flow shown in FIG. 3A can be reinitiated and followed by subsequent reinitiation of the flow shown in FIG. 3B.

[00182] In aspects shown in FIGs. 3A and 3B, the oxidant can comprise  $\geq 10.0\%$  (molar basis) of  $O_2$  in air and/or of  $O_2$  obtained from air. The alkane can comprise  $\geq 10.0\%$  (molar basis) of one or more of  $C_1$  to  $C_5$  linear, iso, and cyclo alkane.

[00183] Aspects shown in FIGs. 3A and 3B can be used as the hydrocarbon conversion reactors 100 and 200 in FIGs. 1 and 2 respectively. In such an instance, the first and second reaction mixtures shown in FIGs. 3A and 3B can be sent via the respective lines 106 and 206 in FIGs. 1 and 6 for further processing by the various selective removal of  $CO_2$  and water, and particularly for selective  $C_2$  separation by a selective  $C_2$  sorption system.

[00184] In other aspects (not shown), at least a portion of the separated olefin can be polymerized. For example, in certain aspects in which the separated olefin comprises ethylene, the ethylene is polymerized, e.g., to produce a polyethylene composition.

[00185] Referring to FIGs. 3A and 3B for further examples of the mixtures that can be used, the first feed mixture's oxidant stream can comprise  $\geq 99.0$  wt. % of  $O_2$ , e.g.,  $O_2$  obtained from air, based on total weight of the first feed mixture's oxidant. The first feed mixture's alkane stream can comprise  $\geq 99.0$  wt. % methane based on total weight of the first feed mixture's alkane. Additionally, the first feed mixture can have a methane : molecular oxygen molar ratio in the range of 10.0 to 20.0. When the oxidant of the first feed mixture comprises  $O_2$  in air, the  $N_2$  and other gases in the air are considered to be diluent components of the total feed, not oxidant components.

[00186] The second feed mixture's oxidant stream, with further reference to FIGs. 3A and 3B, can also comprise  $\geq 99.0$  wt. % of  $O_2$ , e.g.,  $O_2$  obtained from air, based on total weight of the second mixture's oxidant. The second feed mixture's alkane stream can comprise  $\geq 99.0$  wt. % methane based on the weight of the second feed mixture's alkane. Additionally, the second feed mixture can have a methane : molecular oxygen molar ratio in the range of 10.0 to 20.0. When the second feed mixture comprises  $O_2$  in air, the  $N_2$  and other gases in the air are considered to be diluent components of the total feed, not oxidant components.

[00187] The invention is not limited to aspects shown only in the Figures. For example, in other aspects, hydrocarbon conversion reactor can comprise a honeycomb monolith in the form of an elongated polygonal body. The honeycomb can comprise two or more portions, the portions being in side-to-side contact, with each section having one or more flow passages feeding into a flow passage in the adjacent portion. That is, the portions can be adjacent to each other, with each upstream of the mixing means or each downstream of the mixing means.

[00188] In other aspects, the hydrocarbon conversion reactor can include three, four, five, six or more thermal masses, each thermal mass having one or more than one reaction zone. The reactor zones in the hydrocarbon conversion reactor can be adjacent to each other or may optionally have a mixing means (e.g., mixing components or a gap) disposed between the portions.

[00189] While the present invention has been described and illustrated with respect to certain aspects, it is to be understood that the invention is not limited to the particulars disclosed and extends to all equivalents within the scope of the claims. Unless otherwise stated, all percentages, parts, ratios, etc. are by weight. Unless otherwise stated, a reference to a compound or component includes the compound or component by itself as well as in combination with other elements, compounds, or components, such as mixtures of compounds. Further, when an amount, concentration, or other value or parameter is given as a list of upper preferable values and lower preferable values, this is to be understood as specifically disclosing all ranges formed from any pair of an upper preferred value and a lower preferred value, regardless of whether ranges are separately disclosed. All patents, test procedures, and other documents cited herein, including priority documents, are fully incorporated by reference to the extent such disclosure is not inconsistent and for all jurisdictions in which such incorporation is permitted.

**CLAIMS**

1. A process for producing and isolating a C<sub>2</sub> composition, comprising:
  - (a) providing a hydrocarbon reactant and an oxidant, wherein the hydrocarbon reactant comprises  $\geq 10\%$  methane (molar basis, per mole of hydrocarbon reactant);
  - (b) catalytically converting at least a portion of the hydrocarbon reactant's methane in the presence of the oxidant and a hydrocarbon conversion catalyst to produce a reaction mixture comprised of (i) a C<sub>2</sub> composition produced by the catalytic conversion, (ii) CO<sub>2</sub> produced during the catalytic conversion, and (iii) unconverted methane; and
  - (c) exposing the reaction mixture to at least one sorbent under kinetic sorption conditions to selectively remove from the reaction mixture at least a portion of the reaction mixture's C<sub>2</sub> composition to produce a C<sub>2</sub> lean mixture, wherein
    - (i) the C<sub>2</sub> lean mixture comprises at least a portion of the unconverted methane and has a C<sub>2</sub> content that is less than that of the reaction mixture, and
    - (ii) the sorbent comprises C<sub>2</sub> selective sorbent having a selectivity for [ethane + ethylene] over that of methane  $> 1.0$ .
2. The process of claim 1, wherein the reaction mixture is exposed to the C<sub>2</sub> selective sorbent temperature of  $\geq 50^{\circ}\text{C}$ .
3. The process of claim 1 or 2, wherein the process further comprises selectively removing at least a portion of the reaction mixture's CO<sub>2</sub>, the CO<sub>2</sub> removal being carried out before step (c).
4. The process of any of claims 1-3, further comprising selectively removing from the reaction mixture at least a portion of any water, the water removal being carried out before step (c).
5. The process of any of claims 1-4, further comprising desorbing a desorb composition from the C<sub>2</sub> selective sorbent after step (c), wherein the desorb composition comprises methane, ethane, and ethylene, and exposing the desorb composition to at least one olefin-selective sorbent under kinetic sorption conditions to selectively remove from the desorb composition at least a portion of the desorb composition's ethylene.
6. The process of any of claims 1-5, wherein the hydrocarbon reactant comprises  $\geq 90\%$  methane and the conversion catalyst comprises at least one oxidative coupling catalyst.

7. The process of claim 6, wherein the hydrocarbon reactant further comprises  $\geq 1\%$  C<sub>2+</sub> alkane (molar basis, per mole of hydrocarbon reactant) and the conversion catalyst comprises at least one oxidative coupling catalyst and at least one oxydehydrogenation catalyst.
8. The process of any of claims 1-7, wherein the oxidant comprises O<sub>2</sub> and the catalytic conversion is carried out at a methane : O<sub>2</sub> molar ratio of  $> 2:1$ .
9. The process of any of claims 1-8, wherein the oxidant comprises  $\geq 20\%$  O<sub>2</sub> (molar basis, per mole of oxidant) and the catalytic conversion is carried out at a methane : O<sub>2</sub> molar ratio of  $\geq 4:1$ .
10. The process of any of claims 1-9, wherein (i) the oxidant comprises  $\geq 90\%$  O<sub>2</sub> (molar basis, per mole of oxidant), (ii) the hydrocarbon reactant comprises  $\geq 90\%$  methane (molar basis, per mole of hydrocarbon reactant), and (iii) the hydrocarbon further comprises  $\geq 1\%$  of one or more C<sub>2</sub> to C<sub>5</sub> linear, iso, and cyclo alkane (molar basis, per mole of hydrocarbon reactant).
11. The process of any of claims 1-10, wherein the C<sub>2</sub> selective sorbent comprises at least one transition metal that exhibits  $\pi$ -complexation with olefins and an electron affinity  $\geq 1.0$  ev.
12. The process of any of claims 1-11, wherein the C<sub>2</sub> selective sorbent includes at least one shape-selective material.
13. The process of any of claims 1-12, wherein C<sub>2</sub> selective sorbent includes at least one molecular sieve.
14. The process of any of claims 1-13, wherein the C<sub>2</sub> selective sorbent is an olefin-selective sorbent having chemoselectivity and shape selectivity.
15. The process of any of claims 1-14, wherein the catalytic conversion of step (b) is carried out in a reverse-flow reactor.
16. The process of claim 15, wherein the reverse flow reactor includes first and second regions, the first region contains at least a portion of the hydrocarbon conversion catalyst, and the second region contains at least a portion of the C<sub>2</sub> selective sorbent.
17. A process for producing and isolating a C<sub>2</sub> composition comprising:
  - (a) providing first and second hydrocarbon reactants and first and second oxidants, wherein the first and second hydrocarbon reactants each comprise  $\geq 10\%$  methane (molar basis, per mole of hydrocarbon reactant) and the first and second oxidants each comprise O<sub>2</sub>;
  - (b) catalytically converting at least a portion of the first hydrocarbon reactant in

the presence of the first oxidant and a hydrocarbon conversion catalyst to produce a first reaction mixture comprised of (A) a C<sub>2</sub> composition produced by the catalytic conversion, (B) water and/or CO<sub>2</sub> produced during the catalytic conversion, and (C) unconverted methane, wherein:

- i) the catalytic conversion is carried out in a reverse-flow reactor, which comprises a first thermal mass, a second thermal mass, and the hydrocarbon catalyst, and
  - ii) the first mixture is produced by combining the first hydrocarbon reactant and the first oxidant at a methane : O<sub>2</sub> molar ratio of > 2:1; and
- (c) exposing the reaction mixture to at least one sorbent under kinetic sorption conditions to selectively remove from the first reaction mixture at least a portion of the first reaction mixture's C<sub>2</sub> composition to produce a first C<sub>2</sub> lean mixture comprised of at least a portion of the unconverted methane, wherein
- (i) the first C<sub>2</sub> lean mixture has a C<sub>2</sub> content less than that of the first reaction mixture, and
  - (ii) the sorbent comprises C<sub>2</sub> selective sorbent having a selectivity for [ethane + ethylene] over that of methane > 1.0.

18. The process of claim 17, wherein  $\geq 50.0$  wt. % of the first thermal mass, based on total weight of the first thermal mass, is located in a first region of the reverse-flow reactor,  $\geq 50.0$  wt. % of the second thermal mass, based on total weight of the second thermal mass, is located in a second region of the reverse-flow reactor, and  $\geq 50$  wt. % of the hydrocarbon conversion catalyst, based on total of the hydrocarbon conversion catalyst, is located in a third region of the reverse-flow reactor, the third region being located between the first and second regions.

19. The process of claim 18, wherein the first thermal mass is a heated first thermal mass, the catalytic conversion is carried out in a first time interval, and the first interval includes the steps of:

- i. passing the first hydrocarbon reactant and the first oxidant to the reverse-flow reactor;
- ii. transferring heat from the heated first thermal mass to at least one of the first hydrocarbon reactant and the first oxidant and combining the hydrocarbon reactant and the first oxidant to produce a first heated feedstock mixture;

- iii. producing the first reaction mixture by carrying out step (b) using the first hydrocarbon reactant and the first oxidant of the first heated feedstock mixture;
- iv. transferring heat from the first reaction mixture to the second thermal mass to produce a heated second thermal mass; and
- v. carrying out step (c) and then lessening or discontinuing the passing of the first hydrocarbon reactant and the first oxidant to the reverse-flow reactor.

20. The process of claim 19, wherein the catalytic conversion is further carried out in a second time interval following the first time interval and the second time interval includes the steps of:

- i. passing the second hydrocarbon reactant and the second oxidant to the reverse-flow reactor;
- ii. transferring heat from the heated second thermal mass to at least one of the second hydrocarbon reactant and the second oxidant and combining the second hydrocarbon reactant and the second oxidant to produce a second heated feedstock mixture;
- iii. producing a second reaction mixture by catalytically converting at least a portion of the second hydrocarbon reactant in the presence of the second oxidant and the hydrocarbon conversion catalyst, the second reaction mixture comprising (A) a C<sub>2</sub> composition produced by the catalytic conversion, (B) water and/or CO<sub>2</sub> produced during the catalytic conversion, and (C) unconverted methane;
- iv. transferring heat from the second reaction mixture to the first thermal mass to produce a re-heated first thermal mass; and
- v. exposing the second reaction mixture to at least one sorbent under kinetic sorption conditions to selectively remove from the second reaction mixture at least a portion of the second reaction mixture's C<sub>2</sub> composition to produce a second C<sub>2</sub> lean mixture, wherein:
  - (A) the second C<sub>2</sub> lean mixture comprises at least a portion of the second reaction mixture's unconverted methane,
  - (B) the second C<sub>2</sub> lean mixture has a C<sub>2</sub> content less than that of the second reaction mixture; and
  - (C) the sorbent comprises C<sub>2</sub> selective sorbent having a selectivity for [ethane + ethylene] over that of methane > 1.0; and



- vi. lessening or discontinuing the passing of the second reactant and the second oxidant to the reverse-flow reactor.
21. The process of claim 20 wherein the same C<sub>2</sub> selective sorbent is utilized in both of (A) step v of the first time interval and (B) step v of the second time interval.
22. The process of claim 20 wherein a first C<sub>2</sub> selective sorbent is utilized in step v of the first time interval, a second C<sub>2</sub> selective sorbent is utilized in step v of the second time interval, and the first and second C<sub>2</sub> selective sorbents have substantially the same composition.
23. The process of any of claims 20-22, further comprising desorbing ethylene from the C<sub>2</sub> selective sorbent of step v of the first time interval and/or desorbing ethylene from the C<sub>2</sub> selective sorbent of step v of the second time interval.
24. A hydrocarbon conversion process, comprising:
- a. providing a first reactant and a first oxidant, wherein the first reactant comprises  $\geq 10.0\%$  C<sub>5</sub>- alkane (molar basis, per mole of first reactant) and the first oxidant comprises O<sub>2</sub>;
  - b. providing a second reactant and a second oxidant, wherein the second reactant comprises  $\geq 10.0\%$  C<sub>5</sub>- alkane (molar basis, per mole of second reactant) and the second oxidant comprises O<sub>2</sub>;
  - c. providing a reverse-flow reactor comprising a heated first thermal mass, a second thermal mass, and at least one hydrocarbon conversion catalyst;
  - d. during a first time interval,
    - i. passing the first reactant and the first oxidant to the reverse-flow reactor;
    - ii. transferring heat from the heated first thermal mass to at least one of the first reactant or first oxidant and combining the first reactant and first oxidant to produce a first feedstock mixture, the first feedstock mixture having a methane : O<sub>2</sub> molar ratio  $\geq 2.0$ ;
    - iii. catalytically converting at least a portion of the first feedstock's mixture's C<sub>5</sub>- alkane in the presence of the hydrocarbon conversion catalyst to produce a first reaction mixture, the first reaction mixture comprising (A) ethylene produced by the alkane conversion and (B) unconverted C<sub>5</sub>- alkane;
    - iv. transferring heat from the first reaction mixture to the second thermal mass;

v. exposing the first reaction mixture to at least one first sorbent to selectively sorb ethylene from the first reaction mixture to produce a first ethylene-lean mixture, wherein:

(A) the first ethylene-lean mixture comprises at least a portion of the first reaction mixture's unconverted C<sub>5</sub>-alkane,

(B) the first ethylene-lean mixture has an ethylene content less than that of the first reaction mixture; and

(C) the C<sub>2</sub> selective sorbent comprises olefin-selective sorbent; and

vi. lessening or discontinuing the passing of the first mixture to the reverse-flow reactor; and

e. during a second time interval,

i. passing the second reactant and second oxidant to the reverse-flow reactor;

ii. transferring heat from the heated second thermal mass to at least one of the second reactant or second oxidant and combining the second reactant and second oxidant to produce a second feedstock mixture, the second feedstock mixture having a methane : O<sub>2</sub> molar ratio  $\geq 2.0$ ;

iii. catalytically converting at least a portion of the second feedstock mixture's methane in the presence of the hydrocarbon conversion catalyst to produce a second reaction mixture, the second reaction mixture comprising (A) ethylene produced by the catalytic conversion and (B) unconverted C<sub>2</sub> composition;

iv. transferring heat from the second reaction mixture to the first thermal mass to re-heat the first thermal mass;

v. exposing the second reaction mixture under kinetic sorption conditions to at least one second C<sub>2</sub> selective sorbent to selectively sorb ethylene from the second reaction mixture to produce an ethylene-lean mixture, wherein:

(A) the second ethylene-lean mixture comprises at least a portion of the second reaction mixture's unconverted C<sub>5</sub>-alkane,

(B) the second ethylene-lean mixture has an ethylene content less than that of the second reaction mixture; and

(C) the C<sub>2</sub> selective sorbent comprises olefin-selective sorbent; and

vi. lessening or discontinuing the passing of the second mixture to the reverse-flow reactor.

25. The process of claim 24, further comprising desorbing at least a portion of the sorbed ethylene from the first C<sub>2</sub> selective sorbent after step (d) vi and/or desorbing at least a portion of the sorbed ethylene from the second C<sub>2</sub> selective sorbent after step (e) vi.
26. A process for producing and isolating a C<sub>2</sub> composition, comprising:
- (a) providing a hydrocarbon reactant and an oxidant, wherein the hydrocarbon reactant comprises  $\geq 10\%$  alkane (molar basis, per mole of hydrocarbon reactant);
  - (b) catalytically converting at least a portion of the hydrocarbon reactant's alkane in the presence of the oxidant and a hydrocarbon conversion catalyst to produce a reaction mixture comprised of (A) a C<sub>2</sub> composition produced by the catalytic conversion, (B) water and/or CO<sub>2</sub> produced during the catalytic conversion, and (C) unconverted alkane; and
  - (c) exposing the reaction mixture under kinetic sorption conditions to at least one sorbent to selectively remove from the reaction mixture at least a portion of the reaction mixture's C<sub>2</sub> composition to produce a C<sub>2</sub> lean mixture, wherein:
    - (i) the C<sub>2</sub> lean mixture comprises at least a portion of the unconverted alkane and has a C<sub>2</sub> content that is less than that of the reaction mixture, and
    - (ii) the sorbent comprises at least one C<sub>2</sub> selective sorbent having a selectivity for [ethane + ethylene] over that of methane  $> 1.0$ .
27. A hydrocarbon conversion system for producing a C<sub>2</sub> composition, comprising:
- (a) a reactor comprising:
    - (i) a first region having a first thermal mass and a first aperture,
    - (ii) a second region having a second thermal mass and a second aperture, and
    - (iii) a catalytic conversion zone containing catalyst having an oxidative coupling functionality, oxydehydrogenation functionality or both, with at least a portion of the catalyst being deposited on or in at least one of the first thermal mass and second thermal mass,wherein the first and second regions are configured for flowing a feed mixture to enter the reactor proximate to the first aperture, with one or more components of a reaction mixture exiting the reactor proximate to the second aperture; and
  - (b) a sorption system operating under kinetic sorption conditions in fluid communication with the second aperture for receiving at least a portion of the catalytically converted reaction mixture,

wherein the sorption system includes at least one C<sub>2</sub> selective sorbent having a selectivity for [ethane + ethylene] over that of methane > 1.0.

28. A reverse-flow hydrocarbon conversion system for producing a C<sub>2</sub> composition, comprising:

- (a) a reverse-flow reactor comprising
  - (i) a first region having a first thermal mass and a first aperture,
  - (ii) a second region having a second thermal mass and a second aperture,and
  - (iii) a catalytic conversion zone containing catalyst having an oxidative coupling functionality, oxydehydrogenation functionality or both, with at least a portion of the catalyst being deposited on or in at least one of the first thermal mass and second thermal mass,

wherein the first and second regions are configured for flowing a first flow of a first feed mixture to enter the reactor proximate to the first aperture, with one or more components of a first reaction mixture exiting the reactor proximate to the second aperture, and for flowing a second flow of a second feed mixture to enter the reactor proximate to the second aperture, with one or more components of the second reaction mixture exiting the reactor proximate to the first aperture; and

- (b) a sorption system operating under kinetic sorption conditions in fluid communication the first and second apertures for receiving at least a portion of the catalytically converted first and second reaction mixtures,

wherein the sorption system includes at least one C<sub>2</sub> selective sorbent having a selectivity for [ethane + ethylene] over that of methane > 1.0.

1/3

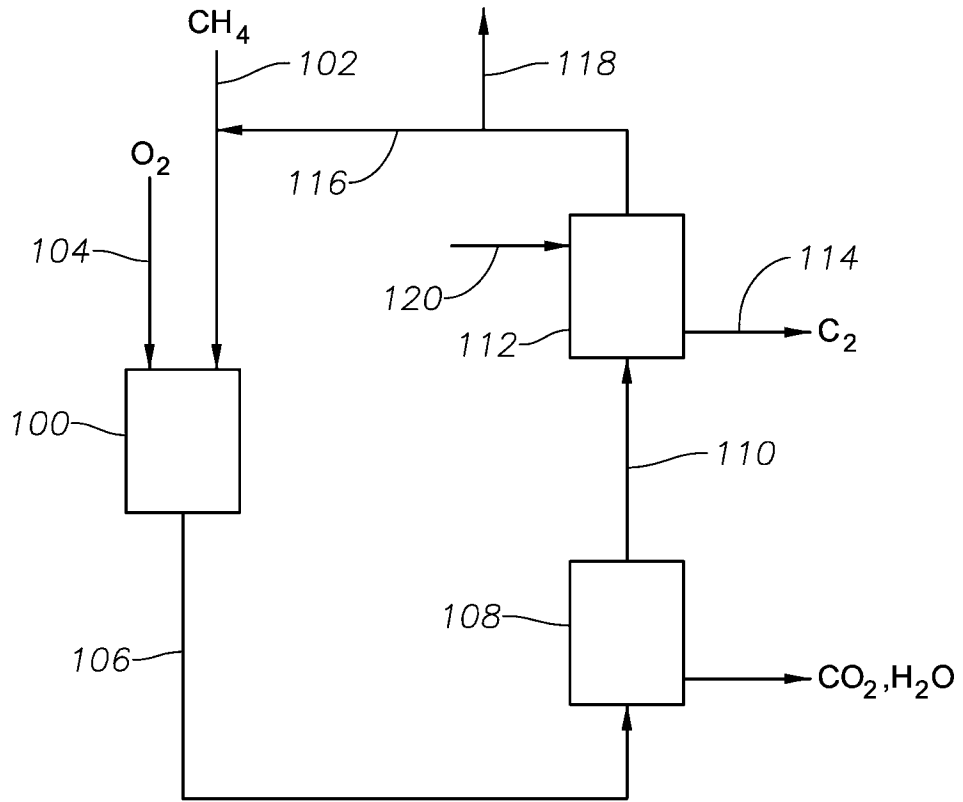
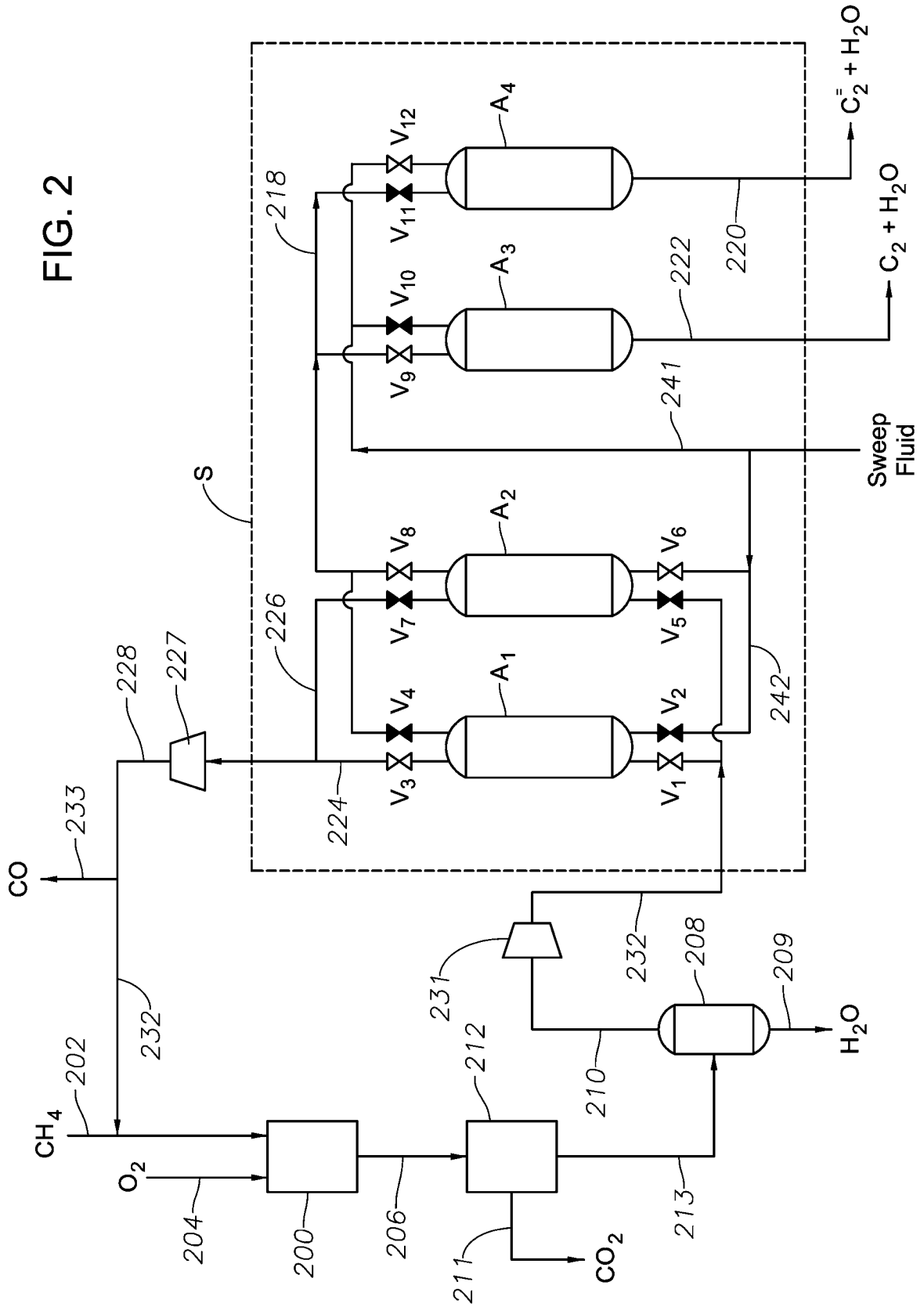

FIG. 1

FIG. 2



3/3

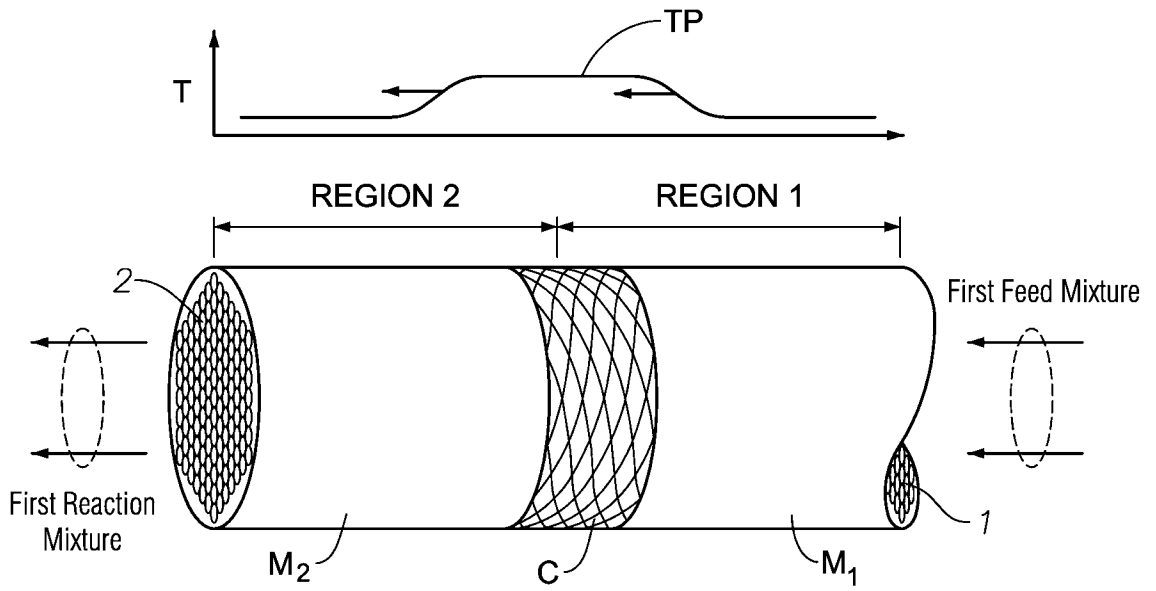

FIG. 3A

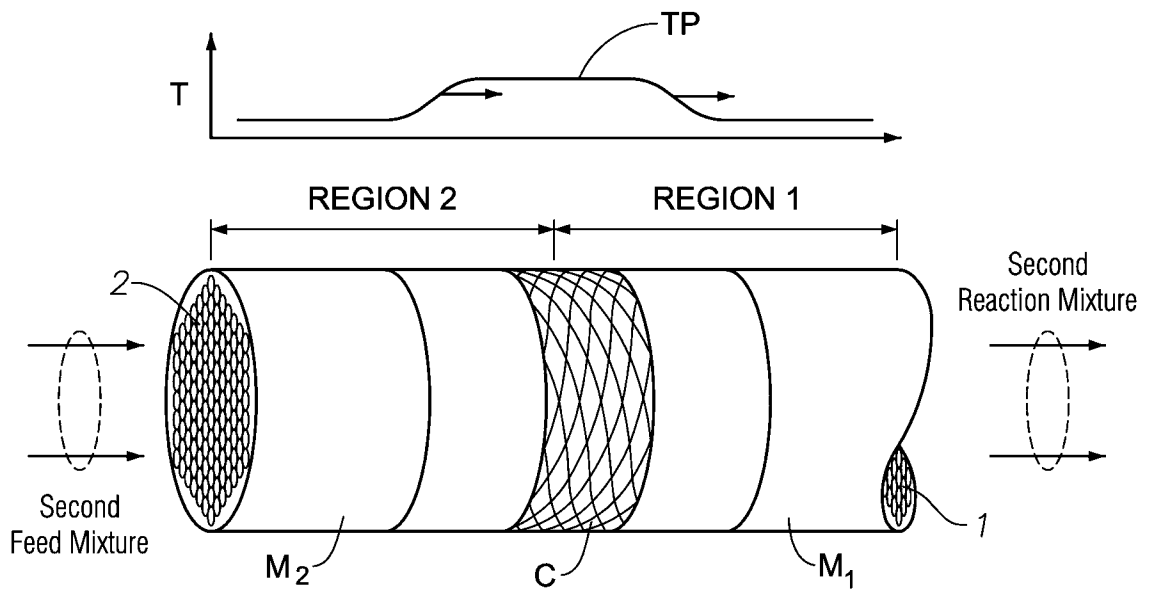

FIG. 3B

## INTERNATIONAL SEARCH REPORT

International application No  
PCT/US2014/052722A. CLASSIFICATION OF SUBJECT MATTER  
INV. C07C2/84 C07C11/04  
ADD.

According to International Patent Classification (IPC) or to both national classification and IPC

## B. FIELDS SEARCHED

Minimum documentation searched (classification system followed by classification symbols)  
C07C

Documentation searched other than minimum documentation to the extent that such documents are included in the fields searched

Electronic data base consulted during the international search (name of data base and, where practicable, search terms used)

EPO-Internal, WPI Data

## C. DOCUMENTS CONSIDERED TO BE RELEVANT

Category*	Citation of document, with indication, where appropriate, of the relevant passages	Relevant to claim No.
X	A. L. TONKOVICH ET AL: "Enhanced C2 Yields from Methane Oxidative Coupling by Means of a Separative Chemical Reactor", SCIENCE, vol. 262, no. 5131, 8 October 1993 (1993-10-08), pages 221-223, XP055149447, ISSN: 0036-8075, DOI: 10.1126/science.262.5131.221 cited in the application page 221, column 3 - page 222 -----	1,2,6,8,9
X	US 5 095 161 A (ABREVAYA HAYIM [US] ET AL) 10 March 1992 (1992-03-10)  column 3, line 2 - column 4, line 50 ----- -/--	1,3,6-10,12,13

 Further documents are listed in the continuation of Box C. See patent family annex.

\* Special categories of cited documents :

"A" document defining the general state of the art which is not considered to be of particular relevance

"E" earlier application or patent but published on or after the international filing date

"L" document which may throw doubts on priority claim(s) or which is cited to establish the publication date of another citation or other special reason (as specified)

"O" document referring to an oral disclosure, use, exhibition or other means

"P" document published prior to the international filing date but later than the priority date claimed

"T" later document published after the international filing date or priority date and not in conflict with the application but cited to understand the principle or theory underlying the invention

"X" document of particular relevance; the claimed invention cannot be considered novel or cannot be considered to involve an inventive step when the document is taken alone

"Y" document of particular relevance; the claimed invention cannot be considered to involve an inventive step when the document is combined with one or more other such documents, such combination being obvious to a person skilled in the art

"&amp;" document member of the same patent family

Date of the actual completion of the international search

30 October 2014

Date of mailing of the international search report

20/01/2015

Name and mailing address of the ISA/

European Patent Office, P.B. 5818 Patentlaan 2  
NL - 2280 HV Rijswijk  
Tel. (+31-70) 340-2040,  
Fax: (+31-70) 340-3016

Authorized officer

Patteux, Claudine



## INTERNATIONAL SEARCH REPORT

International application No  
PCT/US2014/052722

C(Continuation). DOCUMENTS CONSIDERED TO BE RELEVANT		
Category*	Citation of document, with indication, where appropriate, of the relevant passages	Relevant to claim No.
X	US 4 754 093 A (JEZL JAMES L [US] ET AL) 28 June 1988 (1988-06-28) figures column 3, line 29 - column 8, line 9 examples 169-171 claims	1,3-10
X	----- US 4 751 336 A (JEZL JAMES L [US] ET AL) 14 June 1988 (1988-06-14) examples 169-174 claims	1,6-10
X	----- WO 95/20556 A1 (VAYENAS CONSTANTINOS G [GR]; YENTEKAKIS IOANNIS V [GR]; JIANG YI [GR]) 3 August 1995 (1995-08-03) page 2, line 30 - page 3, line 32 page 7, line 24 - page 8, line 30 examples claims	1,6,8,9, 13,14
X	----- WO 02/24614 A1 (UNION CARBIDE CHEM PLASTIC [US]) 28 March 2002 (2002-03-28) page 15, line 21 - page 16, line 22 page 23, line 9 - page 24, line 5 page 33, line 17 - page 36, line 25 figures 3,5 claims examples	1,4,5,7, 8,10,11 15,16
Y	----- MLECZKO L ET AL: "Catalytic oxidative coupling of methane - reaction engineering aspects and process schemes", FUEL PROCESSING TECHNOLOGY, ELSEVIER BV, NL, vol. 42, no. 2-3, 1 April 1995 (1995-04-01), pages 217-248, XP002576965, ISSN: 0378-3820, DOI: 10.1016/0378-3820(94)00121-9 [retrieved on 2000-03-13] page 239, paragraph 3.3 -----	15,16

# INTERNATIONAL SEARCH REPORT

International application No.  
PCT/US2014/052722

## Box No. II Observations where certain claims were found unsearchable (Continuation of item 2 of first sheet)

This international search report has not been established in respect of certain claims under Article 17(2)(a) for the following reasons:

1.  Claims Nos.:  
because they relate to subject matter not required to be searched by this Authority, namely:
  
2.  Claims Nos.:  
because they relate to parts of the international application that do not comply with the prescribed requirements to such an extent that no meaningful international search can be carried out, specifically:
  
3.  Claims Nos.:  
because they are dependent claims and are not drafted in accordance with the second and third sentences of Rule 6.4(a).

## Box No. III Observations where unity of invention is lacking (Continuation of item 3 of first sheet)

This International Searching Authority found multiple inventions in this international application, as follows:

see additional sheet

1.  As all required additional search fees were timely paid by the applicant, this international search report covers all searchable claims.
2.  As all searchable claims could be searched without effort justifying an additional fees, this Authority did not invite payment of additional fees.
3.  As only some of the required additional search fees were timely paid by the applicant, this international search report covers only those claims for which fees were paid, specifically claims Nos.:
4.  No required additional search fees were timely paid by the applicant. Consequently, this international search report is restricted to the invention first mentioned in the claims; it is covered by claims Nos.:

1-16

### Remark on Protest

- The additional search fees were accompanied by the applicant's protest and, where applicable, the payment of a protest fee.
- The additional search fees were accompanied by the applicant's protest but the applicable protest fee was not paid within the time limit specified in the invitation.
- No protest accompanied the payment of additional search fees.

## FURTHER INFORMATION CONTINUED FROM PCT/ISA/ 210

This International Searching Authority found multiple (groups of) inventions in this international application, as follows:

## 1. claims: 1-16

A process for producing and isolating a C<sub>2</sub> composition, comprising:

- (a) providing a hydrocarbon reactant and an oxidant, wherein the hydrocarbon reactant comprises > 10% methane (molar basis, per mole of hydrocarbon reactant);
- (b) catalytically converting at least a portion of the hydrocarbon reactant's methane in the presence of the oxidant and a hydrocarbon conversion catalyst to produce a reaction mixture comprised of (i) a C<sub>2</sub> composition produced by the catalytic conversion, (ii) CO<sub>2</sub> produced during the catalytic conversion, and (iii) unconverted methane; and
- (c) exposing the reaction mixture to at least one sorbent under kinetic sorption conditions to selectively remove from the reaction mixture at least a portion of the reaction mixture's C<sub>2</sub> composition to produce a C<sub>2</sub>lean mixture, wherein
  - (i) the C<sub>2</sub>lean mixture comprises at least a portion of the unconverted methane and has a C<sub>2</sub> content that is less than that of the reaction mixture, and
  - (ii) the sorbent comprises a C<sub>2</sub>selective sorbent having a selectivity for [ethane + ethylene] over that of methane > 1.0.

---

## 2. claims: 17-28

A process for producing and isolating a C<sub>2</sub> composition comprising:

- (a) providing first and second hydrocarbon reactants and first and second oxidants, wherein the first and second hydrocarbon reactants each comprise > 10% methane (molar basis, per mole of hydrocarbon reactant) and the first and second oxidants each comprise O<sub>2</sub>;
- (b) catalytically converting at least a portion of the first hydrocarbon reactant in the presence of the first oxidant and a hydrocarbon conversion catalyst to produce a first reaction mixture comprised of (A) a C<sub>2</sub> composition produced by the catalytic conversion, (B) water and/or CO<sub>2</sub> produced during the catalytic conversion, and (C) unconverted methane, wherein:
  - i) the catalytic conversion is carried out in a reverse-flow reactor, which comprises a first thermal mass, a second thermal mass, and the hydrocarbon catalyst, and
  - ii) the first mixture is produced by combining the first hydrocarbon reactant and the first oxidant at a methane : O<sub>2</sub> molar ratio of > 2:1; and
- (c) exposing the reaction mixture to at least one sorbent under kinetic sorption conditions to selectively remove from the first reaction mixture at least a portion of the first reaction mixture's C<sub>2</sub> composition to produce a first C<sub>2</sub>lean mixture comprised of at least a portion of the unconverted

FURTHER INFORMATION CONTINUED FROM PCT/ISA/ 210

methane, wherein  
(i) the first C<sub>2</sub>lean mixture has a C<sub>2</sub>content less than that  
of the first reaction mixture, and  
(ii) the sorbent comprises C<sub>2</sub>selective sorbent having a  
selectivity for [ethane + ethylene] over that of  
methane>1.0.

---

# INTERNATIONAL SEARCH REPORT

Information on patent family members

International application No PCT/US2014/052722
---

Patent document cited in search report	Publication date	Patent family member(s)	Publication date
US 5095161	A	10-03-1992 NONE	
-----			
US 4754093	A	28-06-1988 CA 1265537 A1 US 4754093 A	06-02-1990 28-06-1988
-----			
US 4751336	A	14-06-1988 CA 1259338 A1 US 4751336 A	12-09-1989 14-06-1988
-----			
WO 9520556	A1	03-08-1995 AU 678808 B2 AU 5890794 A CN 1119852 A DE 69415978 D1 EP 0701544 A1 JP H08508516 A WO 9520556 A1	12-06-1997 15-08-1995 03-04-1996 25-02-1999 20-03-1996 10-09-1996 03-08-1995
-----			
WO 0224614	A1	28-03-2002 AR 033572 A1 AU 9266601 A AU 2001292666 B2 BR 0114133 A CA 2421816 A1 CN 1458915 A EP 1322581 A1 JP 2004509155 A KR 20030034191 A MX PA03002441 A MY 117933 A NO 20031209 A US 6518476 B1 WO 0224614 A1	26-12-2003 02-04-2002 21-07-2005 29-07-2003 28-03-2002 26-11-2003 02-07-2003 25-03-2004 01-05-2003 24-05-2004 30-08-2004 13-05-2003 11-02-2003 28-03-2002
-----			