

(21) Application No 8504434

(22) Date of filing 21 Feb 1985

(30) Priority data

(31) 3406296 (32) 22 Feb 1984 (33) DE  
3429369 9 Aug 1984

(51) INT CL<sup>3</sup>  
B08B 3/02

(52) Domestic classification  
A4F 29A1E1BX 29A1E2 29A3B

(56) Documents cited  
GB 1445008 GB 1239786 GB 1235504  
GB 1219878 GB 1175748 GB 0988989

(58) Field of search  
A4F

(71) Applicants  
Stohrer-Doduco GmbH & Co (FR Germany)  
Romerstrasse 35, 7250 Leonberg, Federal Republic of  
Germany

(72) Inventors  
Gerhard Herdtle  
Helmut Steins

(74) Agent and/or Address for Service  
Matthews Haddan & Co, Haddan House, 33 Elmfield Road,  
Bromley, Kent BR1 1SU

(54) Machine for washing circuit boards

(57) A machine for washing parts 37 of plate form e.g. circuit boards comprises a housing 11 containing a rotatable carrier 29 for the parts and sprayers 146 for spraying cleaning liquid e.g. water onto the parts. The sprayers may rotate as shown, or may be fixed above the carrier. The wet parts may be dried by hot air blown through duct 57.

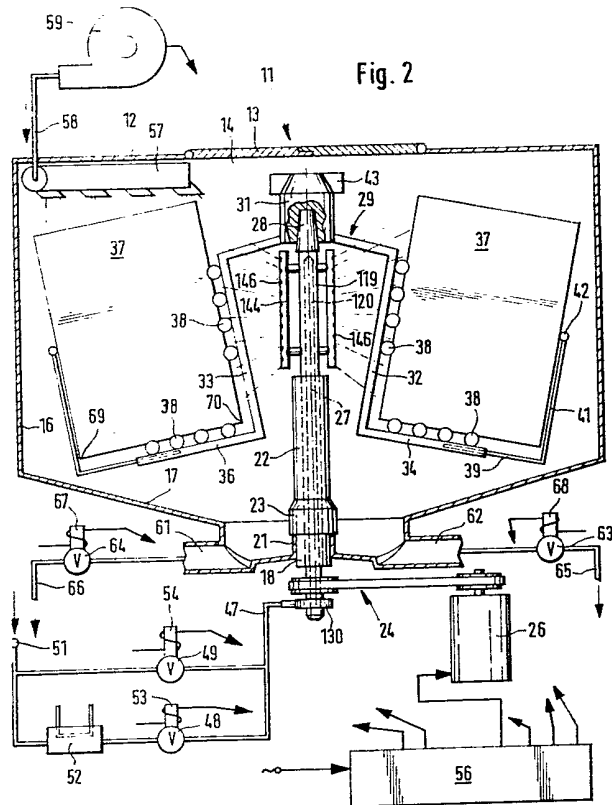

GB 2 154 434 A

1/2

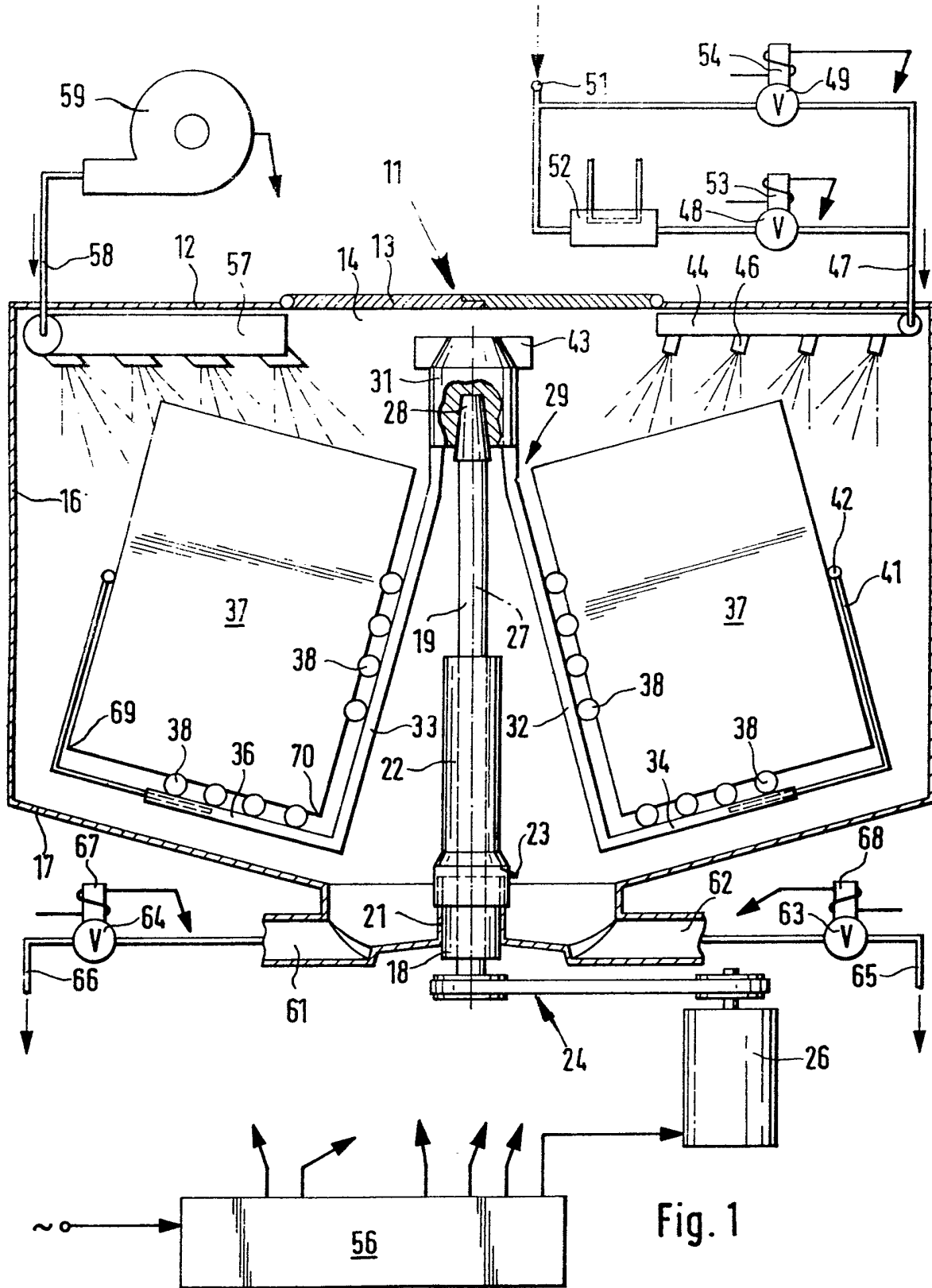
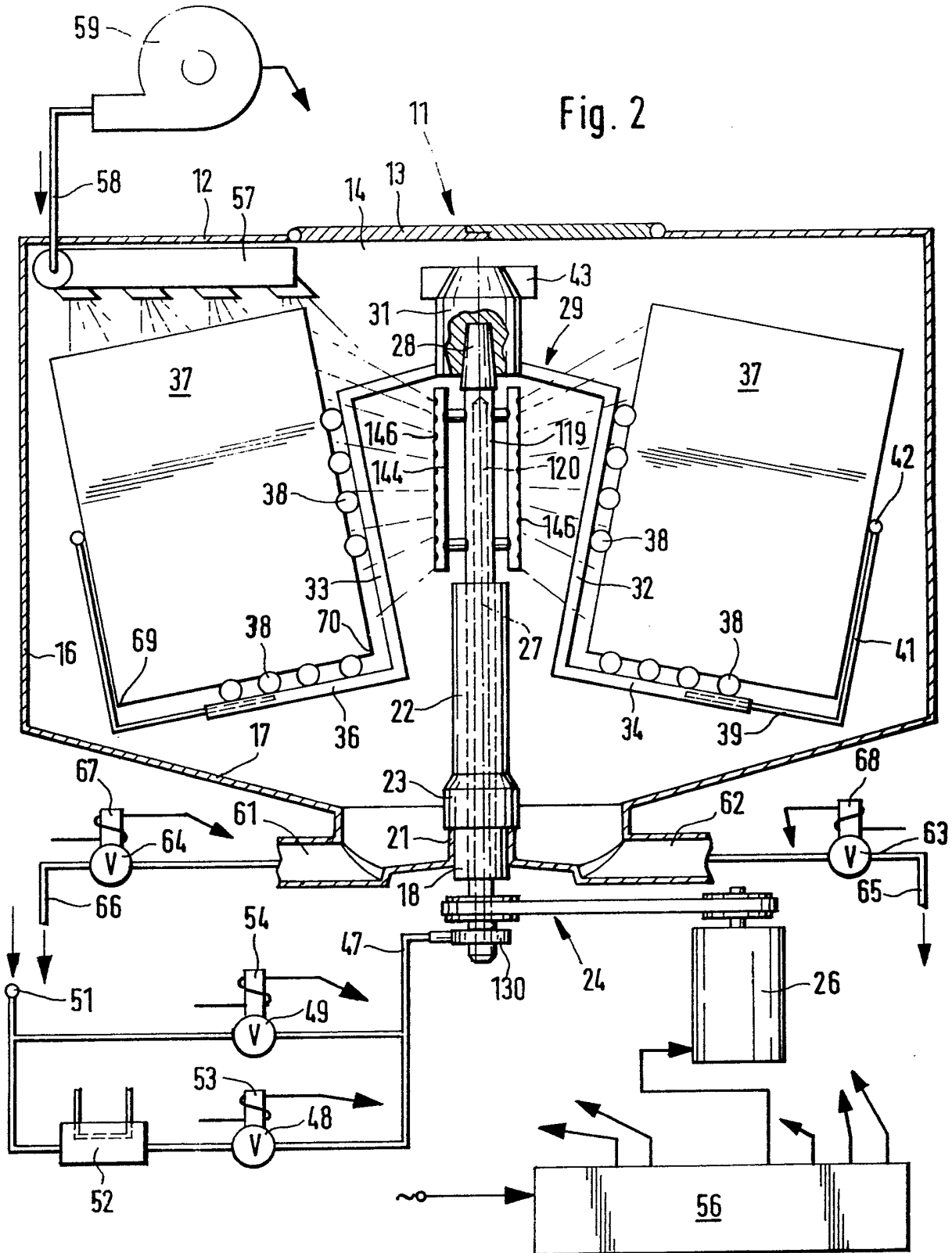

Fig. 1

Fig. 2



## SPECIFICATION

**Liquid cleaning installation**

5 The invention relates to a liquid cleaning installation for parts of plate form.

10 The parts of plate form are primarily circuit boards such as are usual for the production of printed circuits in electrical engineering. Such boards are exposed to a plurality of mechanical and chemical treatments and amongst other things the bores with diameters of 0.5 to 1.2 mm. necessary for the fitting in of the circuit elements are also put in. It is the task of the cleaning installation to free the plates both from mechanical soiling and from chemical substances which would be 15 troublesome in the subsequent treatment. Thus any mordants must be rinsed out. The many small bores, in which higher concentrations of such chemical substances also remain, in this case make these tasks especially more difficult.

20 In conventional liquid cleaning installations of the classification concerned therefore the cleaning takes place in each case in two successive stages. Firstly the plates are piled with mutual spacing in a basket which is inserted from above into the housing. Thereupon 25 cleaning liquid is sprayed through the spray nozzles against the plates. At that time the drain is opened. Thus the main soiling is rinsed away. Then the drain is closed and a second cleaning liquid is charged into the closed housing through a flood valve until all the 30 plates are completely immersed. Above the plates there is an overflow so that dirt components rising to the liquid surface, especially foam, can be removed by this route. This flooding has the purpose of reducing the chemical residues in the bores to a tolerable 35 concentration. After a certain time of immersion the lid of the housing is opened and the basket with the plates is removed upwards. At the same time the drain of the housing is opened.

40 The fact that the cleaning effect especially in the small bores is not satisfactory is a disadvantage here. Moreover the cleaning takes very much time, on the one hand as a result of the two successive cleaning phases and also on account of the limited filling speed in the filling of the housing. A further disadvantage is 45 the high liquid consumption. Thus in the first spraying phase 1 cu.m./h. and in the second flooding phase about 10 cu.m./h. of water are consumed. Therefore a conversion has been made to re-using the water for the second flooding phase as often as possible, which 50 necessitates the installation of a filter and ion exchanger plant. While this re-use reduces the fresh water and drainage costs, so that the installation covers its cost in about a term of a year, constant attention to the ion exchangers is necessary. In the cost calculations it 55 is mostly also overlooked that this water processing occupies very much space which could also be used more productively. Circulating pumps and other trouble-prone installations are also present here on failure of which under some circumstances the entire 60 circuit board manufacture is destroyed.

A further disadvantage consists in that the plates can be taken therefrom only in a wet condition which necessitates the installation of a separate drying plant.

65 It is the problem of the invention to develop a liquid cleaning installation of the classification concerned so that the cleaning effect is improved and the consumption of cleaning fluid is finally reduced.

70 According to the invention there is provided a liquid cleaning installation characterised in that a rotatable carrier for parts of plate form is arranged in a housing.

75 As a result of the rotating movement the cleaning liquid sprayed upon the plates is washed at considerably higher speed of flow over the plate surface than is the case due to the force of gravity alone in the case of static arrangement. Moreover turbulences and 80 oscillations result which also promote better washing through of the small bores. Since thus the cleaning effect as a whole is significantly improved in this spray phase, the necessity of a subsequent flood washing is eliminated. Accordingly the great liquid consumption of such flooding washing is saved whereby the 85 expense for the re-preparation of the necessary liquid is also eliminated. The liquid cleaning installation according to the invention thus provides a substantial reduction of the plant operating costs with improved cleaning effect. The cleaning time is also shorter, since it is no longer necessary to wait until the housing is filled with liquid.

90 Claims 2 to 5, 9 to 11 and 19 state expedient developments of the carrier for the parts of plate form.

95 Claims 6 to 8, 17 and 18 indicate advantageous developments as regards the retaining fitting.

100 Claims 12 to 16 indicate operational developments in connection with a control apparatus which result in an especially advantageous utilisation of the cleaning installation.

The invention will next be explained in greater detail by reference to preferred examples of embodiment represented in diagrammatically simplified manner in 105 the drawing.

The liquid cleaning installation according to Figure 1 comprises firstly a housing 11 with a housing top 12 in which an inlet opening 14 closable by flaps 13 is provided. The housing side walls 16 define a somewhat cubic chamber, and at the bottom the housing 11 105 is closed by a housing bottom 17. Legs supporting the housing 11 on the floor are not separately illustrated.

110 Approximately in the middle of the housing bottom 17 a shaft bearing 18 is secured in which a shaft 19 pointing vertically in the direction of the housing top 12 is rotatably mounted. The shaft bearing 18 is here fixed in a flange extension 21 which extends upwards a few centimetres from the bottom. On the shaft 19 there is arranged in tightly abutting manner a sleeve 115 22 which with its lower marginal region 23 covers over the flange extension 21 in the manner of a cap but contactlessly. Thus a labyrinth centrifugal seal is formed which prevents penetration of liquid into the shaft bearing 18.

120 The lower end of the shaft 19 is connected with a motor 26 for example through a V-belt transmission 24. The shaft 19 then rotates about the axis 27 of rotation. The upper end of the shaft 19 is formed as a pyramid frustum 28.

125 In the drawing there is further represented a carrier

29 arranged in the interior of the housing 11. It consists essentially of a saddle socket 31 which has an aperture on its under side corresponding to the pyramid frustum 28 and thus can be easily fitted in shape-  
 5 engaging manner on to the shaft 19. Two first carrier arms 32 and 33 extend from the saddle socket 31 each at an acute angle to the rotation axis 27 and in symmetrical alignment therewith in the direction towards the housing bottom 17. The end of each is  
 10 adjoined by a second carrier arm 34 and 36 protruding radially approximately at right angles thereto. Thus a configuration is obtained in which the first carrier arms 32 and 33 form a V with one another while the first and second carrier arms in each case form an L.  
 15 On the carrier arms there are fitted retaining elements for parts 37 of plate form, for example in the form of horizontally disposed bars 38. These bars are provided with transverse grooves so that a pack consisting of several parts 37 of plate form can be accommodated symmetrically on each of the two sides of the  
 20 rotation axis. Each pack can here consist of up to about forty parts of plate form which are held side by side at a distance of about 10 mm. One leg 39 of an L-shaped retaining bar 41 is guided telescopically in each of the  
 25 two carrier arms 34 and 36. At the other end of the retaining bar 41 there is a horizontal strip 42 which can be applied to the outer edges of the parts 37 of plate form and thus holds the packs fast on the carrier. Naturally other constructions for pack formation are  
 30 also possible. By way of example it is also possible to use what are called cassettes, which then are completely fitted and connected with the carrier. According to the formation of the cassette it is possible to dispense with the second carrier arm if its supporting  
 35 function is taken over by the cassette.

The drawing shows that the saddle socket 31 lies approximately in a plane corresponding to the upper edges of the plates, when the largest plate format to be handled is present. The carrier 29 is thus situated in a  
 40 very stable position of equilibrium.

The saddle socket 31 is prolonged somewhat upwards and carries two radial gripping journals 43 at its upper end. Gripping claws (not shown separately) of a hoist transport apparatus can engage beneath  
 45 these gripping journals 43 and then lift the carrier 29 out of the housing 11 and transport it to another treatment station. For the withdrawal and insertion of the loaded carrier 29 from and into the housing 11 the carrier must be rotated through 90° out of the position  
 50 as illustrated in the drawing, and then it can be moved through the rectangular inlet opening 14 which extends substantially over the whole depth of the housing.

Laterally beside the inlet opening 14 there is  
 55 situated beneath the housing top 12 a connection fitting 44 supplying a row of spray nozzles 46. These may be a whole area of spray nozzles. The spray nozzles 46 are here directed against the parts 37 of plate form. The connection fitting 44 is connected  
 60 through a diagrammatically indicated conduit 47 with two valves 48 and 49. The valve 49 is in communication at the other end directly with a feed connection 51 to which the cleaning liquid, for example fresh water, is supplied at sufficient pressure. The other connection of the valve 48 is connected with this feed  
 65

connection 51 through the intermediary of a heat exchanger 52. This signifies that the cleaning liquid supplied by this route can be heated. The operating magnets 53 and 54 are connected through indicated  
 70 control leads with a control apparatus 56.

In the opposite region of the housing top 12 there is a connection fitting 57 from which air nozzles directed on to the parts 37 of plate form issue. Correspondingly the connection fitting 57 is connected through a  
 75 diagrammatically indicated passage 58 with a heating blower 59. This is controllable in a manner known *per se* and the associated control lead leads likewise to the control apparatus 56, as indicated in the drawing.

The motor 26 is also influenced by the control  
 80 apparatus 56, which is likewise symbolised by a corresponding control lead. In the region of the housing bottom 17 at the lowest point there are two drain fittings 61 and 62, to each of which there is allocated a valve 63 and 64 respectively. The actuating  
 85 magnets 68 and 67 of these valves 63 and 64 are connected through control leads with the control apparatus 56. The conduit 65 leading away from the valve 63 leads by way of a first used water treatment plant (not represented separately) into a used water  
 90 passage while the conduit 66 leading away from the valve 64 likewise reaches by way of a second used water treatment plant to the used water passage. The used water treatment plants utilised can be specialised so that in the one water-containing complex (for  
 95 example with copper constituents) and in the other complex-free water is pre-cleaned in accordance with legal requirements. According to the occurring soiling substances it is thus possible to open the appropriate drainage route.

The manner of operation of the cleaning installation is now to be described below. Firstly let it be assumed that the carrier 29 is charged with the two packs of parts 37 of plate form at a charging station outside the  
 100 housing 11. In this stage the circuit boards are drilled and are then subjected to a series of chemical treatments. For this purpose the carrier 29 is grasped by the gripping journals 43, driven over a first treatment bath and lowered into the latter. After conclusion of this treatment the carrier is grasped  
 105 again, lifted out of the treatment bath and driven to the cleaning installation. Here the flaps 13 are opened and the carrier is inserted through the open inlet opening 14 into the housing 11, the saddle socket 31 coming into position on the pyramid frustum 28 of the shaft 19.  
 110 The gripper device is again withdrawn upwards and the flaps 13 are closed. This then instigates a cleaning cycle pre-programmed in the control apparatus 56.

Firstly the motor 26 is switched on at low speed and the valve 49 and one of the valves 63, 64 are opened. In  
 120 this way the parts 37 of plate form are moved past below the nozzles 46 and vigorously sprayed. A large part of the superficial soiling is thereby already rinsed away. After an adjustable spray phase the rotation speed of the motor 26 is increased continuously or by  
 125 stages. This has the consequence that the horizontal movement component of the parts 37 in relation to the water drops increases to such extent that the water is also forced into the bores. On further increase of the rotation speed finally the centrifugal effect predominates more and more and the water flows at great force  
 130

radially outwards over the surfaces of the parts 37. This down-flowing water film also has a kind of suction effect leading to the freeing of the small bores. Since the parts 37 act like radial vanes, in addition a quite considerable air current occurs which likewise exerts a suction effect in relation to the small bores and forces the liquid to the outer edge of the plates. This signifies that as from a certain rotation rate dependent upon the plate size the spray nozzles 46 achieve not further appreciable effect, because they then no longer arrive against the air current and against the centrifugal force. This limit range naturally depends upon the style of construction of the spray nozzles and the available water pressure. Thus as long as the parts are still to be sprayed with fresh water, the rotation rate must remain below the above-mentioned limit value.

After this spray phase it is therefore advisable to step up the motor rotation rate to the final centrifuging rotation rate and to halt the supply of cleaning liquid.

If the centrifuged parts are not yet sufficiently dry for the subsequent treatment process, the heating blower 59 can now be activated which through the connection fitting 57 blows appropriately heated air in between the parts 37 of plate form.

The Figure shows that the parts 37 of plate form are always held in the cleaning installation so that their lower plate edges are inclined in relation to the horizontal. This has the consequences that in centrifuging the final residue of the liquid film flows along the lower plate edge and/or along the outer plate edge to the corner 69 which is situated furthest outwards and splashes away from the latter according to the known corner effect. If on the other hand during the first spray phase the rotation rate is still very low, the water can collect along the lower plate edge and the plate inner edge towards the inner corner 70 in order to flow away here likewise exploiting the corner effect.

The above-described drying by means of hot air can be replaced by the operational variant which will be described below. It consists in that after the spray cleaning and before the motor 26 is switched over to its final centrifuging rate, the valve 49 is closed and instead the valve 48 is opened. Thus heated water (hot water) arrives on the parts 37 of plate form. After a pre-settable time which is dimensioned so that the parts heat up sufficiently, the valve 48 is closed again whereupon the motor 26 is accelerated to the final centrifuging rotation rate. After centrifuging in combination with the preceding heating with hot water, a very good drying effect likewise results.

According to choice the drying can be effected in one or the other manner or even by a combination of the two above-mentioned manners. It is understood that it is possible to dispense completely with the heat exchanger 52 and the valve 48 if the installation is to be operated exclusively with air drying. Conversely it is possible to dispense completely with the fitting 57 and the heating blower 59 if it is not intended to use air drying.

If the fitting 57 is not provided, it is possible instead to provide a second fitting at that point similar to the fitting 44. Thus it is possible to provide an area of spray nozzles 46 over each of the two packs of parts 37. In this case it is not absolutely necessary to set the carrier

29 in rotation during the initial spray phase. It is also possible in this initial phase to control the motor 26 so that the two opposite packs are moved each only slightly to and fro beneath the nozzle areas lying above them in order to make the water distribution more uniform.

It is clear that the cleaning proceeds more rapidly if twice as many spray nozzles are arranged in the housing 11, for in the embodiment as illustrated in the drawing each pack is situated in the range of effect of the spray nozzles 46 only during a part of the circulating movement.

A further variant is not separately illustrated, which consists in that the cleaning liquid is supplied to the feed connection 51 with variable pressure which is likewise varied according to a predetermined programme by the control device 56, namely in a manner in which with increasing motor rotation rate the spray pressure also increases in order more intensely to compensate for the deflection effect as a result of centrifugal force and air flow.

The drawing illustrates a cleaning installation reduced in size by about the factor 10. Thus the housing 11 has a length of size of about 1.6 m. The maximum rotation rate of the carrier 29 lies in the range of 200 to 300 rpm. The water consumption lies approximately in the same order of magnitude as in the spray cleaning phase according to the prior art, that is about 1 cu.m./h.

The air flow occurring in the rotation also leads to micro vibrations of the parts, whereby the cleaning effect is additionally reinforced in the small bores.

The liquid cleaning installation is designed predominantly for cleaning circuit boards. Of course other parts of plate form can however also be cleaned therewith. The plates also do not need to have a symmetrical rectangular form or a flat upper surface. It is understood that the retention of the parts is to be adapted to the form of the parts and that correspondingly the construction of the carrier 29 can also vary. Water is used predominantly as cleaning liquid but any other cleaning liquid can also be utilised.

An especially preferred development of the invention is represented in Figure 2. The fundamental assembly is the same as in the example described above and accordingly the same reference numerals are also used for like parts. Reference is made to the corresponding description above.

Firstly the fitting of the spray nozzles is different. For this purpose a modified shaft 119 is provided which comprises a passage 120 extending up from the lower terminal region lying outside the housing bottom 17 into the region of the parts 37 of plate form. A connection fitting 144 per pack with spray nozzles 146 is fitted in this upper region fast in rotation on the shaft 119, so that an adequate number of spray nozzles 146 is allocated to each pack of parts 37 of plate form. In the lower end region a rotatable connection 130 of known construction type is mounted on the shaft 119 and the stationary conduit 47 (from the previous example) is connected to it. By this route the cleaning liquid is fed to the passage 120 and thus to the spray nozzles 146. It is understood that the passage 120 is otherwise closed to the exterior.

The particular advantage of this development

consists in that as a result of the rotation-accompanying spray nozzles 146 the cleaning liquid can be distributed better over the parts 37 of plate form, with the aim of an improved cleaning effect.

- 5 A further difference from the previous example consists in the formation of the carrier 29 to such effect that now the inclination of the lower plate edge is so predetermined that the corner 70 closer to the axis lies higher than the corner 69 remote from the axis. Thus  
10 especially in combination with the central spray nozzle arrangement, better drainage of the cleaning liquid over the parts 37 is achievable.

#### CLAIMS

1. Liquid cleaning installation, characterised in  
15 that a rotatable carrier (29) for parts (37) of plate form is arranged in a housing (11).

2. Liquid cleaning installation for parts of plate form, having a housing of box form, having a carrier insertable into the housing and on which parts of plate  
20 form can be retained with mutual spacing, having a closable inlet opening in the region of the housing top through which the carrier is insertable from above into the housing, having a retaining fitting in the housing on which the inserted carrier can be fitted, the plane of  
25 the parts of plate form being aligned approximately vertically, having spray nozzles arranged in the housing and directed against the parts, having connection and valve fittings for the supply of the cleaning liquid to the spray nozzles, and having drainage and  
30 valve fittings in the region of the housing bottom for draining the cleaning liquid, characterised in that the carrier (29) is rotatably supported on the retaining fitting in the housing (11), with the axis (27) of rotation standing substantially vertically, while the plane of the  
35 parts (37) of plate form is directed at least approximately radially of the rotation axis, and in that a rotating drive system (24, 26) is provided for the inserted carrier (29).

3. Liquid cleaning installation according to Claim  
40 2, characterised in that the carrier (29) is equipped to receive two packs arranged symmetrically in relation to the rotation axis (27), each pack being formed by a plurality of parts (37) of plate form held approximately parallel side by side with spacing, while the plane of  
45 the middle part of plate form of each pack is directed at least approximately radially of the rotation axis.

4. Liquid cleaning installation according to Claim 2  
or 3, characterised in that the parts (37) of plate form are retainable on the carrier (29) in such a way that the  
50 lower plate edge is inclined in relation to the horizontal.

5. Liquid cleaning installation according to Claim 3  
or 4, characterised in that a pack comprises about forty parts (37) of plate form which are stacked side by side  
55 at an interval of about 10 mm.

6. Liquid cleaning installation according to one or more of the preceding Claims, characterised in that the retaining fitting comprises a shaft (19) mounted rotatably in the region of the housing bottom (17) and  
60 pointing with one end vertically in the direction of the housing top (12), the carrier (29) being fittable with a saddle socket (31) on to this end (28).

7. Liquid cleaning installation according to Claim  
6, characterised in that the shaft (19) is guided with its  
65 lower end by the housing bottom (17) and is in

communication by this end with a rotating drive system (24, 26).

8. Liquid cleaning installation according to Claim  
7, characterised in that a seal between the housing  
70 bottom (17, 21) and the shaft (19, 23) is formed as a labyrinth centrifugal seal.

9. Liquid cleaning installation according to Claim  
6, characterised in that the carrier (29) comprises two first carrier arms (32, 33) secured symmetrically of the  
75 rotation axis (27) each to the saddle socket (31) and directed at an acute angle to the rotation axis, the end of each of which is radially adjoined by a second carrier arm (34, 36) protruding approximately at right angles thereto and in that retaining elements (38) for  
80 the parts (37) of plate form are fitted on the carrier arms.

10. Liquid cleaning installation according to Claim  
9, characterised in that the saddle socket (31) possesses an extension reaching upwards in the direction of  
85 the rotation axis (27), on the end of which extension there are formed radial gripping journals (43).

11. Liquid cleaning installation according to Claim  
9, characterised in that the length and fitting of the first carrier arms (32, 33) are determined in such a way that  
90 the saddle socket (31) lies approximately in a plane corresponding to the upper edge of the plates, when parts (37) of plate form of the largest plate format to be handled are inserted, which parts (37) are supported with their lower plate edges in the plane of the second  
95 carrier arms (34, 36).

12. Liquid cleaning installation according to one of the preceding Claims, characterised in that a control apparatus (56) is provided for the predeterminable  
100 setting of the jet pressure of the spray nozzles (46) and of the rotation rate of the rotating drive system (26).

13. Liquid cleaning installation according to Claim  
12, characterised in that the control apparatus (56) is arranged to open the valve fittings (49) for the supply  
105 of cleaning liquid when the rotation of the carrier (29) is halted or predeterminably reduced, in order after a predeterminable duration of spraying to increase the rotation rate up to a final centrifuging rotation rate, the valve fittings (49) being closed at the latest when the final centrifuging rotation rate is reached.

14. Liquid cleaning installation according to Claim  
13, characterised in that in the interval before the final centrifuging rotation rate is reached further valve  
110 fittings (48) are opened by the control apparatus (56) for the supply of a heated cleaning liquid to the spray nozzles (46), the supply of cold cleaning liquid being halted at the same time.

15. Liquid cleaning installation according to Claim  
13, characterised in that air nozzles are also arranged in the region below the housing top (12) and are  
120 connected with connection and valve fittings (57) for the supply of heated air, these being opened by the control apparatus (56) at least in the final period of operation at the final centrifuging rotation rate.

16. Liquid cleaning installation according to one of the preceding Claims, characterised in that at least  
125 two drain and valve fittings (61, 62, 63, 64) are provided for differentiated conducting away of the soiled cleaning liquid according to the nature of the used water.

17. Liquid cleaning installation according to Claim

2, characterised in that the spray nozzles (146) are arranged radially inwards of the parts (37) of plate form and to rotate with them.

18. Liquid cleaning installation according to

5 Claims 6 and 17, characterised in that the shaft (119) comprises a passage (120) reaching up from the lower end region lying outside the housing bottom (17) into the region of the parts (37) of plate form, in that the spray nozzles (146) are arranged fast in rotation on the shaft (119) and connected with the passage (120) and  
10 in that in the lower end region a rotatable connection (130) is mounted on the shaft (119), to which connection a stationary conduit (47) for the supply of the cleaning liquid is connectable.

15 19. Liquid cleaning installation according to Claim 4, characterised in that the inclination of the lower plate edge of the parts (37) of plate form is predetermined by the carrier (29) in such a way that the corner (70) close to the axis lies higher than the corner (69)  
20 remote from the axis.

20. Liquid cleaning installation substantially as described herein with reference to Figures 1 and 2 of the accompanying drawings.

---

Printed in the United Kingdom for Her Majesty's Stationery Office, 8818935, 9/85, 18996. Published at the Patent Office, 25 Southampton Buildings, London WC2A 1AY, from which copies may be obtained.