

(No Model.)

T. FALK & A. FRAZIER.
SAFETY VALVE.

No. 308,479.

Patented Nov. 25, 1884.

Fig. 1.

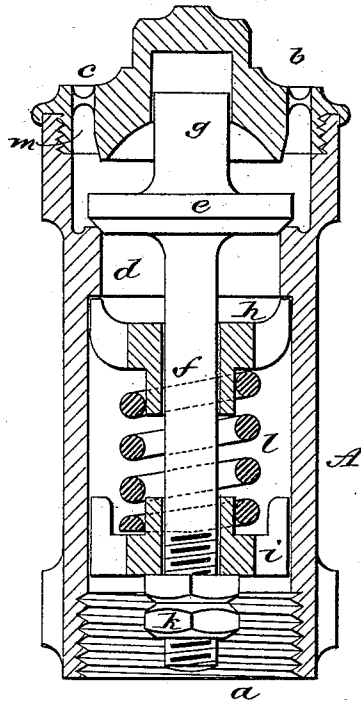

Fig. 2.

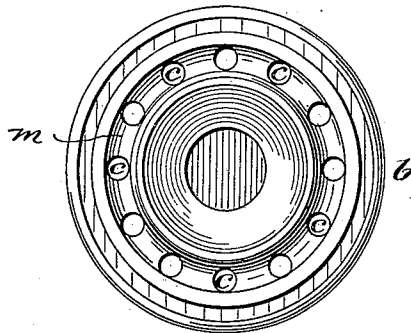
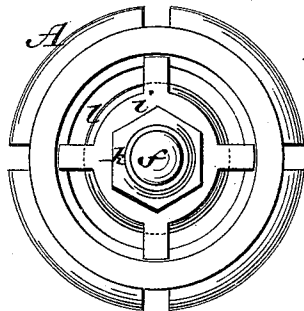

Fig. 3.



WITNESSES:

Hobbes
C. Sedgwick

INVENTOR:

T. Falk
A. Frazier
Munn & Co
ATTORNEYS.

BY

UNITED STATES PATENT OFFICE.

THEODOR FALK AND ALEXANDER FRAZIER, OF MAYWOOD, ILLINOIS.

SAFETY-VALVE.

SPECIFICATION forming part of Letters Patent No. 308,479, dated November 25, 1884.

Application filed May 22, 1884. (No model.)

To all whom it may concern:

Be it known that we, THEODOR FALK and ALEXANDER FRAZIER, of Maywood, in the county of Cook and State of Illinois, have invented a new and useful Improvement in Safety-Valves, of which the following is a full, clear, and exact description.

The object of our invention is to furnish a reliable safety-valve for steam, air, or water under pressure, in which the working parts are not accessible; and it consists in a novel construction of valve, as hereinafter described and claimed.

Reference is to be had to the accompanying drawings, forming a part of this specification, in which similar letters of reference indicate corresponding parts in all the figures.

Figure 1 is a longitudinal section of our safety-valve. Fig. 2 is an inverted plan view of the cap, and Fig. 3 is an end view of the device.

The body A of the valve, which is of cylindrical form, is made with a thread at one end, *a*, for its attachment to a boiler, and the outer end is closed by a screw-cap, *b*, having in it a circle of holes, *c*, or slots for escape of steam. Within the body, a short distance below the cup, is an annular flange, *d*, that has its upper edge grooved and beveled as a valve-seat for the disk-valve *e*. The valve is made with a stem, *f*, extending to near the end *a*, so as to give access to the nuts for tightening the spring, and it has also a guide-stem, *g*, extending into a recess in cap *b*.

h is a bridge around the stem *f*, having arms that take beneath the flange *d*; and *i* is a similar bridge on the lower end of the stem *f*, above the adjusting-nuts *k*. The bridges *h i* serve to retain the stem and valve central, and bridge *h* also is a cap for the spiral spring *l*, which is around the stem and rests on bridge

i. The upper bridge or spring-holder, *h*, may be attached to the body A, the lower holder, *i*, being loose, to allow rise and fall of the valve. Beneath the holes *c* the cap *b* is made with a groove, *m*, for holding the steam or preventing it from passing to the guide-recess of stem *g*.

The valve being put together as described, the nuts *k* are screwed up to give tension to the spring according to the pressure that the valve is to open at. The body is then screwed to place, and the tension of the spring cannot then be changed without unscrewing the body from its place.

In operation valve *e* rises as soon as the pressure upon it is sufficient to overcome the spring, and the opening allows the steam to escape freely.

Having thus described our invention, we claim as new and desire to secure by Letters Patent—

1. In a safety-valve, the combination, with the body A, provided with the valve-seat *d*, the valve *e*, provided with the stem *f* and guide *g*, the bridges *h i*, spring *l*, and nuts *k*, of the cap *b*, recessed to receive the guide *g*, and provided with the opening *c*, substantially as herein shown and described.

2. In a safety-valve, the combination, with the body A and its valve *e*, provided with the guide *g*, of the cap *b*, recessed to receive the said guide, and provided with the openings *c*, and the groove *m* beneath the said openings, substantially as herein shown and described, and for the purpose set forth.

THEODOR FALK.
ALEXANDER FRAZIER.

Witnesses:

JACOB BOHLANDER,
HENRY WONDERLING.