

(19) World Intellectual Property Organization
International Bureau



(43) International Publication Date
5 July 2001 (05.07.2001)

PCT

(10) International Publication Number
WO 01/48861 A1

- (51) International Patent Classification⁷: **H01Q 1/24**
- (21) International Application Number: PCT/SE00/02534
- (22) International Filing Date:
14 December 2000 (14.12.2000)
- (25) Filing Language: English
- (26) Publication Language: English
- (30) Priority Data:
9904773-0 23 December 1999 (23.12.1999) SE
- (71) Applicant (for all designated States except US): **ALLGON AB** [SE/SE]; P.O. Box 500, S-184 25 Åkersberga (SE).
- (72) Inventors; and
- (75) Inventors/Applicants (for US only): **ERIKSSON, Leif**

[SE/SE]; PL 6676, S-761 93 Norrtälje (SE). **EDVARDSSON, Olov** [SE/SE]; Sandbrovägen 30 A, S-183 30 Täby (SE). **BRAUN, Christian** [DE/SE]; Lokstallsgatan 6, S-113 21 Stockholm (SE).

(74) Agents: **AXELSSON, Rolf** et al.; Kransell & Wennborg AB, Box 27834, S-115 93 Stockholm (SE).

(81) Designated States (national): AE, AG, AL, AM, AT, AT (utility model), AU, AZ, BA, BB, BG, BR, BY, BZ, CA, CH, CN, CR, CU, CZ, CZ (utility model), DE, DE (utility model), DK, DK (utility model), DM, DZ, EE, EE (utility model), ES, FI, FI (utility model), GB, GD, GE, GH, GM, HR, HU, ID, IL, IN, IS, JP, KE, KG, KP, KR, KZ, LC, LK, LR, LS, LT, LU, LV, MA, MD, MG, MK, MN, MW, MX, MZ, NO, NZ, PL, PT, RO, RU, SD, SE, SG, SI, SK, SK (utility model), SL, TJ, TM, TR, TT, TZ, UA, UG, US, UZ, VN, YU, ZA, ZW.

[Continued on next page]

(54) Title: A METHOD AND A BLANK FOR USE IN THE MANUFACTURING OF AN ANTENNA DEVICE

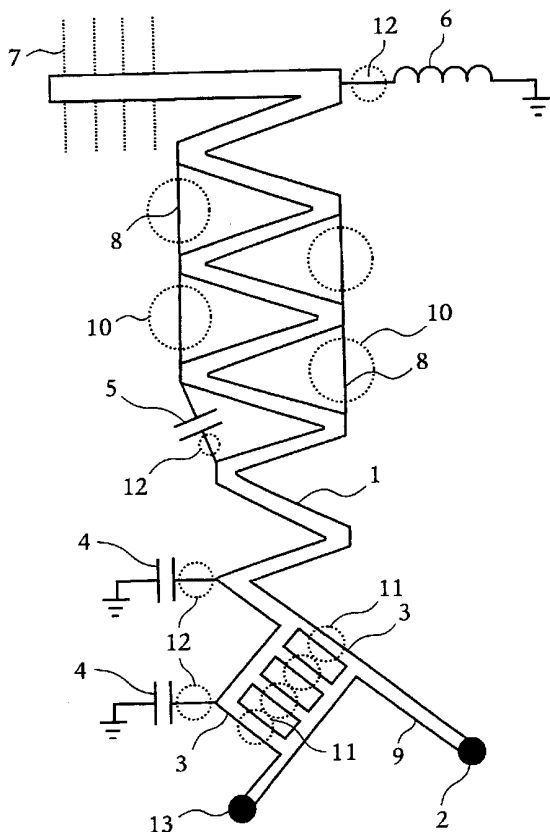

(57) Abstract: A method for manufacturing antenna devices for transmitting and receiving RF waves and having antenna properties adapted to suit a specific model of a radio communication device. The method comprises providing a standard antenna blank to be modifiable in order to enable its antenna properties to be adapted to suit anyone of a plurality of different models of a radio communication device, using at least one physical parameter of a specific model to decide on suitable modifications of the standard antenna blank, effecting the decided modifications of the antenna blank by carrying out at least one of the following operations: making disruptions in electrically conducting paths, electrically interconnecting conductive parts, removing electrically conductive material, and adding electrically conductive material to the antenna blank, and using the obtained modified antenna element as a templet for the manufacturing of antenna devices for other radio communication devices of the same model by effecting corresponding modifications of prefabricated standard antenna blanks of the same kind. The invention also relates to an antenna device manufactured in accordance with the method, to a radio communication device comprising such an antenna device, and to an antenna blank for use when carrying out the method.

WO 01/48861 A1



(84) Designated States (regional): ARIPO patent (GH, GM, KE, LS, MW, MZ, SD, SL, SZ, TZ, UG, ZW), Eurasian patent (AM, AZ, BY, KG, KZ, MD, RU, TJ, TM), European patent (AT, BE, CH, CY, DE, DK, ES, FI, FR, GB, GR, IE, IT, LU, MC, NL, PT, SE, TR), OAPI patent (BF, BJ, CF, CG, CI, CM, GA, GN, GW, ML, MR, NE, SN, TD, TG).

Published:

— *With international search report.*

For two-letter codes and other abbreviations, refer to the "Guidance Notes on Codes and Abbreviations" appearing at the beginning of each regular issue of the PCT Gazette.

A METHOD AND A BLANK FOR USE IN THE
MANUFACTURING OF AN ANTENNA DEVICE

FIELD OF THE INVENTION

5

The present invention relates to a method for manufacturing antenna devices for transmitting and receiving RF waves and having antenna properties adapted to suit a specific model of a radio communication device.

10

The invention also relates to an antenna device manufactured in accordance with the method, to an antenna blank for use when carrying out the method, and to a radio communication device comprising an antenna device manufactured in accordance with the method of the

15

invention.

BACKGROUND OF THE INVENTION

20

In the radio communication systems of today there are an ever increasing demand for making the user devices smaller. This is especially important when it comes to handportable terminals, e.g. portable phones. The design of the handportable terminals must permit the terminals to be easily and rapidly manufactured at low costs. Still the terminals must be reliable in use and exhibit a good performance.

25

30

It is well known that the size of an antenna is critical for its performance, see Johnsson, Antenna Engineering Handbook, McGrawHill 1993, chapter 6. The interaction between antenna, phone body and the close-by environment, such as e.g. the user himself, will become more important than ever. Since recently, there is also normally a requirement that two or more frequency bands shall be supported.

35

This puts requirements on the antenna device to be compact, versatile and to have good antenna performance. It must also be robust, stable, easy to mount, easy to connect, and arranged so as to efficiently use the available space. Interest has also been focused on antenna devices mounted inside the housing of hand-portable terminals. Thereby, protruding antenna parts are avoided.

The radiating properties of an antenna device for a small-sized structure, e.g. for a handportable terminal, such as a portable phone, depends heavily on the shape and size of the conductive parts of the phone, e.g. a printed circuit board, PCB, of the phone, and also on the phone casing if this is electrically conductive. All radiation properties, such as resonance frequency, input impedance, radiation pattern, impedance, polarization, gain, bandwidth, and near-field pattern are products of the antenna device itself and its interaction with the phone body. On top of this, objects in the close-by environment affects the radiation properties. Thus, all references to radiation properties made below are intended to be for the whole device in which the antenna is incorporated.

Historically seen antennas for portable phones have passed the following 5 development steps:

Step 1. Whips having a length of half a wavelength ($\lambda/2$) have been used a lot and are good antennas in terms of performance among other things because they are stand-alone antennas which do not induce strong currents on the phone itself. The clumsy size (about 160 mm above the phone for 800-1000 MHz) has reduced their use but they can be seen on new phones too for high performance in terms of high gain and low losses

in the environment of the phone.

Step 2. Whips of a quarter of a wavelength reduce the length of the whip by 50 %, as compared to the $\lambda/2$ -
5 whip. The shortening is done by substituting the lower half of the antenna by the phone body and as can be expected this involves the phone more in the radiation. Besides the currents along the phone body this whip is
10 a good antenna not the least for its inherent good impedance match. However, its length (about 80 mm above the phone for 800-1000 MHz) may still be considered as too big.

Step 3. Today the most common antenna on a typical
15 portable phone is a "stubby antenna" which can be seen as a shortened version of the $\lambda/4$ -whip. For a long time stubby antennas were of the helical type made of a wire (approximately $\lambda/4$ long) wound on an insulating core to get an exterior length of $\lambda/16$ to $\lambda/8$ (20-40 mm at 800-
20 1000 MHz). Still the helix and the phone body act together to form a kind of an asymmetric $\lambda/2$ dipole. The shorter the helix the bigger part of the radiation will emerge from the phone body itself, especially if the phone itself is small. The helix radiating in the
25 normal mode can be seen as a kind of transmission line where the helical shape is just a way of adding inductance to lower the wave velocity along the line. In practical cases the wire length is known to be in the order of $\lambda/4$ but this is merely accidental as it is the
30 amount of added inductance that counts rather than the wire length.

Step 4. Newer stubby antennas generally have a helix of some other shape, such as a printed circuit formed with
35 a shape of a meander. This gives basically an identical function as the helical shape, and the added inductance

is the important property here too. The important difference is that the meander shape can include conducting paths for more than one frequency, for instance by placing two different meander paths in parallel. As
5 for the wire-wound stubby antennas the radiating structure mainly consists of the phone body itself, i.e. the PCB with its screening cans or the metallic case, if the enclosure is conducting. Thus, the antenna element can be regarded as a feeding structure rather than a
10 radiating structure.

Step 5. The fifth development step is the built-in antenna eliminating the visible antenna which may be an obstacle when taking out the phone from the pocket, for
15 instance. By the discussion above it is obvious that the radiating function of the built-in antenna is very similar to that of the stubby antenna, that is the current through the phone body is the main source of the radiation. A main function of the antenna element
20 is, in both cases, to induce currents in the phone body but obviously the details are different.

The helical/meandering stubby antenna can be seen as a kind of a cap, covering a part of the top of the phone,
25 together with a tuning device making the connection impedance real. The reactive component of a contemplated cap on the top of the phone will be capacitive so an inductive part, inherent in the helix or the meander, will be necessary to tune the antenna element. Apart
30 from this tuning more or less any part located on or near the top of the phone will act as an antenna element with its surface as the critical parameter. A bigger surface can be said to give a better coupling which will be reflected in the radiation conductance or
35 radiation resistance, depending on how the feeding is arranged. The phone body will act as an antenna which

is fairly similar to a half-wave dipole and the local fields from that crude half-wave antenna will determine the coupling to the antenna element together with a "size measure" for the antenna element. For a built-in antenna element the surface of the antenna element is the "size measure" which determines the coupling. It is to be noted that the radiation function is the same for a built-in antenna as for an exterior helical antenna, for instance.

10

From the discussion above a few conclusions may be drawn which can be used as a base for a more unified way for the design of the antenna element of a radio communication device, such as a portable phone, for instance.

15

A. The function of the antenna element is to create a match between the feed connection and the phone itself which is the real antenna in the sense that the phone body is the source of the radiation. The size and location of the antenna element is the most important features.

20

B. As a compromise with aesthetic requirements, etc. a suitable space on the phone is chosen for the antenna element. From the discussion above it is obvious that a big antenna element close to the top of the phone can be expected to give better performance but by using a good design it is possible, within certain limits, to decrease the area of the element while keeping a good antenna performance. One important constraint with the location is to avoid the very top of the phone but rather locate the antenna on the upper part of the back. This will give the current distribution a non-symmetrical pattern by which, for example, it is possible to decrease the fields towards the user and thus

30

35

to decrease the non desired losses due to such fields.

C. Generally, a resonant structure for the antenna element is chosen. This is not at all necessary to obtain the radiation from the antenna but simplifies the impedance matching as any feeding impedance, 50 ohm among others, can be found on the resonant structure by using a suitable feeding point. The practical antenna element on a small phone is small as compared to for instance $\lambda/4$, and some tuning member has to be added, such as a capacitor at the end of a Planar Inverted F-Antenna, PIFA, element, which capacitor will tune the PIFA to a lower frequency. One observation is that the resonance frequency of an antenna element is only weakly influenced by the size of the phone, location of the antenna element, and surrounding elements.

D. After tuning of a resonant antenna element the connection impedance will be essentially real independent of where the connection is done. It is generally desirable to connect it to 50 ohm or some other value suitable with regard to the circuits, etc. By choosing a suitable connection point it is fairly easy to get any desired impedance. For the impedance level a much wider range must be possible to handle as compared to the frequency tuning. The size of the phone, the size of the antenna element, and the location of the antenna element on the phone will have a big influence on the connection impedance at each point.

30

E. As a last step an extra resonant circuit can be added to widen the match which is the conventional method.

35

What has been stated above is true also with respect to radio communication systems used in other apparatus

than portable phones, such as cordless telephones, telemetry systems, wireless data terminals, etc. Thus, even if the antenna device of the invention is described in connection with portable phones it is applicable
5 on a broad scale in various radio communication apparatus.

As the rate at which new models of portable phones are presented is increasing, the time from start of the
10 development of a new model to the start of production and marketing of the same has been drastically shortened during the last few years. Further, there is a demand for a reduction of the manufacturing costs.

15 Today a lot of development work is required to match an antenna to a new type of mobile phone. This is due to the fact that the phone itself is the main radiating structure, and one important objective of the antenna is to match the input impedance with regard to e.g.
20 different shape of the phone.

SUMMARY OF THE INVENTION

In this disclosure it is to be understood that the
25 antenna device of the invention is operable to transmit and/or receive RF signals. Even if a term is used herein that suggests one specific signal direction it is to be appreciated that such a situation can cover that signal direction and/or its reverse.

30 A main object of the present invention is to provide a new method which facilitates the development and manufacturing of antenna devices so that a new model of a portable phone, for instance, can be fitted with an
35 antenna device adapted to that specific model in a very short time.

A further object of the present invention is to provide a method which enables an antenna device for a specific model of a radio communication device to be manufactured from a pre-fabricated antenna blank modifiable to suit anyone of a plurality of different models.

An other object of the invention is to provide an antenna blank which is readily adaptable to anyone of a plurality of models of a radio communication device, and thus can be manufactured in great quantities to reduce the unit cost.

An additional object of the present invention is to provide an antenna blank which can be adapted to anyone of a plurality of models of a radio communication device by carrying out only a few simple work operations.

A further object of the present invention is to provide an antenna blank which can be modified by causing interruptions in, or by interconnecting interrupted parts of electrically conductive paths or connection lines of the antenna blank.

A still further object of the present invention is to provide an antenna blank which can be modified by disconnecting or connecting electrical components (inductors, capacitors, etc.) from and to the antenna blank, respectively.

The present invention is based on the realization that the above objects can be attained by prefabricating a standard antenna blank with a form enabling it to be arranged in a plurality of different models of a radio communication device, and the antenna properties of which antenna blank can be readily modified to suit

anyone of the different models.

Such a standard antenna blank can be rapidly modified to suit a new model of a portable phone, for instance. The modified element can then be used as a templet for the manufacturing of antenna devices for other phones of the same model by effecting corresponding modifications of prefabricated standard antenna blanks of the same kind.

10

This means that the standard antenna blank can be prefabricated in great quantities thus reducing the cost per unit.

15

As has been discussed above the frequency tuning of an antenna element is only weakly influenced by the size of the portable radio communication device and the location of the antenna element so a rather small tuning range will be sufficient for the use of an antenna blank in different portable phones, for instance.

20

The required frequency tuning can be obtained by shaping the standard antenna pattern so that the length thereof can be readily adjusted, for instance by cutting away pieces of the pattern at predetermined positions.

25

The connection impedance of the standard antenna blank must be adjustable to a rather great extent in dependence on the coupling factor which primarily is determined by the size of the phone body, for instance, the area of the antenna element, and the location of the antenna element. The impedance adjustment can be obtained by providing the antenna element with a plurality of feed points and/or a plurality of ground points,

30

35

each individually connected to a common feed, and a common ground connection, respectively. Then a desired feed or ground point can be selected by severing the connection lines leading to the non-elected points.

5

The term meander shaped antenna used in this specification is basically a printed circuit strip, a wire, or an other conductor shaped as a meandering river. Electrically the meander shape means that inductance is added, and the exact shape is not important, Thus in this description and in the claims the term meander is intended to cover many natural variations from the classical meander shape, including coils, fractal patterns and others which essentially add inductance.

10

15 BRIEF DESCRIPTION OF THE DRAWINGS

Figure 1 is a diagrammatical view of a standard antenna blank used for describing the principal idea of the present invention.

20

Figure 2 a-d shows schematically one way of arranging an antenna device according to the present invention in a portable telephone.

25

Figure 3 a-c shows a second way of arranging an antenna device according to the present invention in a portable telephone.

30

Figures 4-6 show different embodiments of meander shaped antenna patterns which are modifiable in accordance with the present invention.

35

Figure 7 shows a modifiable patch antenna element.

Figure 8 shows a modifiable slot antenna element.

Figure 9 shows a meander antenna pattern for double tuning.

5

Figure 10 shows a combination of a meander antenna pattern and a whip antenna.

DETAILED DESCRIPTION OF PREFERRED EMBODIMENTS

10

Figure 1 shows a standard antenna blank which is adaptable in several respects to suit anyone of a plurality of models of a radio communication device. The illustrated antenna element is a meander element and can be applied to any type of carrier, for instance a stiff or a flexible substrate. Using a flexible substrate enables the shape of the substrate to be adapted to the shape of the casing of the radio communication device in which it is to be arranged. This enables an efficient use of the available space and makes it possible to maximize the space between a printed circuit board, PCB, of the radio communication device and the antenna element.

15

20

25

The antenna element can alternatively be applied to the inner surface of the casing of the radio communication device, for instance the back part of the casing of a portable telephone.

30

In figure 1 reference numeral 1 designates the meander shaped antenna element having a feed connection point 2. The position of the feed connection point is fixed irrespectively of which feeding point on the antenna element is used. This is advantageous as it is the point 2 that is to be connected to the circuitry of the radio communication device. The overall geometrical

35

form of the antenna element is designed so that it can be arranged in anyone of a plurality of models of a radio communication device.

5 The illustrated embodiment of a meander shaped antenna element is provided with a number of parallel feed and ground lines 3, all connected to a feed point 2 and a ground point 13 via a common main feed line 9 and a ground line 14, respectively. The antenna element also
10 comprises additional capacitive components 4 connected to ground and a capacitive component 5 connected between two points on the meander pattern, and an inductive component 6 connected to ground. The dotted lines
15 7 illustrate some positions where the length of the ribbon-like antenna element can be adjusted. The reference numerals 8 designate short circuiting lines between different points of the antenna element.

20 The capacitive and inductive components 4, 5, 6 have been illustrated as discrete components. However, the desired capacitance or inductance can easily be provided by means of suitable formed conductive path of the same kind as the conductive path of the antenna element and applied on the same substrate as the antenna ele-
25 ment and connected thereto, as will be exemplified below.

The above mentioned components or short circuiting lines are only shown as examples which will be used in
30 the description of the principal idea of the present invention. However, as is realized by the person skilled in the art there are a numerous of other possibilities of adjusting the length of the antenna element, connecting and combining different components and short
35 circuiting lines, and adjusting the positions of the feeding points and grounding points on the antenna

element, for instance.

For a preliminar frequency tuning of the antenna element one or more of the short circuiting lines 8 are
5 broken, for instance by means of a punch or knife, as indicated by the dotted circles 10. This will make the electrical length of the antenna element longer which lowers the resonance frequency.

10 A fine adjustment of the frequency tuning can be obtained by cutting the end portion of the antenna element at any of the dotted lines 7. Normally, such trimming of the antenna length will be sufficient, and the short circuiting lines 8 can be dispensed with.

15 The impedance of the antenna element can be adjusted to a substantial extent by selecting the position of the feeding point on the antenna element 1. This can be done by electing one of the connection lines 3 connected to the desired feed point on the antenna element
20 1 by severing the feed lines connected to the remaining feed points, by cutting or punching as indicated by the dotted circles 11, for instance. The point at which the ground is connected to the antenna element 1 can be
25 selected in a corresponding way.

The impedance and/or the resonance frequency of the antenna can be further adjusted by detaching one or more of the additional capacitances 4, 5 and/or the
30 inductance 6. This can be done by cutting or punching of the corresponding connection line, as indicated by the dotted circles 12.

Thus, the main idea of the present invention is to
35 provide an antenna blank so designed that it can be transformed into anyone of a great number of antenna

configuration states, each state having its specific antenna performance. Hereby the antenna element can be adapted to anyone of a plurality of radio communication devices demanding antenna properties varying within a wide range. The adaptation is carried out by simple working operations, such as punching or cutting. The cutting can be carried out by means of a cutting edge or a laser beam, for instance.

As alternatives to breaking electrical connections, and/or disconnecting electrical components, new electrical connections can be made, and/or additional electrical components can be connected, for instance by adding electrically conductive material at selected predetermined positions in the pattern.

Electrically conductive material can be added by applying an electrically conductive dye or ink to the antenna blank, for instance by means of an ink-jet printer.

The adaptation of the antenna blank to a specific radio communication device starts with determining at least one physical parameter of said model. This parameter can, for example, be the size of the body of a portable telephone, for instance, the area of the antenna element, or the location of the antenna element on the phone. This physical parameter is used to decide on suitable modifications of the antenna element.

After this first modification the antenna element is arranged in the intended apparatus and the radiating performance is verified. If necessary, an additional fine adjustment of the antenna element is carried out.

When a properly operating antenna element has been obtained this antenna element is used as a templet for the manufacturing of a great number of antenna devices for other radio communication devices of the same model by corresponding modifications of additional prefabricated standard antenna elements of the same design.

Thus, as the standard antenna blank, after required modifications, can be used in anyone of a plurality of different models of a radio communication device these blanks can be manufactured in great quantities, thus reducing the price per unit. Further, this technique makes it possible to manufacture an antenna element with good performance for any new model of a radio communication device in a very short time, as the versatile blank is already in production. What is needed is just an adaptation of the blank to the new model which can be effected by a few punching or cutting operations, for instance.

Figure 2 illustrates schematically how an antenna element 20 can be arranged in a portable telephone. The casing 21 of the telephone is shown in dashed lines in Figure 2d, and comprises two connectable halves. The antenna element 20 has been shown as a meander element having a feed point 22 and a ground point 23. The different adjustment possibilities of Figure 1 has not been shown in Figure 2 for the sake of simplicity.

The antenna element 20 may consist of a conductive pattern printed on a flexible film or on a flexible circuit board. The flexible film or board is applied to a carrier 24 which in this embodiment has the shape of an arch extending from one side to the other of a supporting structure 25 of the portable telephone. The supporting structure 25 can be arranged centrally

within the casing 21, see Figure 2. The remaining circuitry of the telephone and its main Printed Circuit Board, PCB, carried by the supporting structure 25 has not been illustrated.

5

The carrier 24 can be stiff and pre-moulded but comprises preferably a flexible substrate the shape of which can be adapted to the shape of the casing 21. Hereby, the space between the antenna element 20 and the supporting structure carrying the PCB can be maximized. The antenna element is preferably arranged on the inner surface of the carrier 24.

10

Figure 3 shows an alternative according to which the antenna element 30 is arranged on a vaulted carrier 34 the form of which is adapted to the form of the upper part of the telephone casing 31. Reference numerals 32 and 33 denote a feed point and a ground point, respectively, and 35 denotes a supporting structure. Instead of using a separate carrier 24, 34 for the antenna element 20, 30 in Figures 2 and 3, respectively, the antenna element can be arranged directly on the inner surface of the telephone casing.

20

The connection of the preferably flexible antenna pattern to a main PCB of a portable phone, for instance, can be made in many ways. Various pins, metallic strips, or spring loaded connections can be used. However, when the antenna pattern is carried by a flexible film the film can be folded around the edges of the plastic carrier, and be directly pressed towards the PCB by the elastic properties of the carrier in order to obtain the required contact force between the antenna element and conductive lines on the PCB.

30

35

The possibility to adjust the impedance level of the

antenna element is important and must cover a wide range. In the case of an antenna blank for a multi-band antenna comprising two or more meanders (or other shapes of conductive antenna patterns) the blank can be so designed that the feed points can be chosen in a way allowing adequate impedance adjustment of the meanders by a "parallel" choice of the connection points, as will be described below. Improvements can be obtained by including a capacitor (made in the antenna pattern to be adjusted) close to the grounding which gives a suitable frequency dependence in order to enable a coarse frequency compensation. Such a capacitive grounding is very useful.

A considerable problem is to make a good tuning over two or more frequency bands with a possibility to adjust them individually. The solutions described below are applicable to any type of manufacturing techniques for the antenna element, such as printing on a flexible film, stamping a thin plate, etc. Basically three methods are used in the given embodiments. According to a first method two or more parallel meanders are used, and in a second method a non-uniform meander is used which will be adequately tunable for at least two bands. A third method usable to any meander or PIFA (Planar Inverted F-Antenna) pattern is to create a rather narrow band grounding for the high band at the far end of the antenna element. Thus, the antenna element will have an electrical length of $\lambda/4$ for the low band and $\lambda/2$ for the high band. A considerable advantage of this method is that a big efficient surface for the high band is obtained as the whole surface of the element is utilised for both frequencies.

Figure 4 shows an antenna blank according to one embodiment of the invention. The blank comprises two

parallel meander shaped antenna elements 40 and 41 arranged on a preferably flexible carrier 42. The blank is intended for the manufacturing of a dual band antenna, e.g. for the GSM bands 900 MHz and 1.800 MHz.

5 The element 40 is for the lower band and the element 41 for the higher band. Both elements are grounded at the same point 43 at one end of the antenna pattern.

Frequency tuning of the two elements are done by adjusting their lengths by cuts or perforations indicated as circles 44, 45. The most important feature is the individual impedance matching of the two elements 40, 41. This is obtained by selecting a different feed point for each element. To this end the first portions of the two meander elements 40, 41 are arranged close to each other with a common feed line 46 running there between. The feed line 46 connects a common feed connection 47 to two parallel feed branches 48, 49. By cutting these feed branches at selected positions, as indicated by the circles 50, 51, for instance, a desired feed point for each element can be chosen which gives a specific impedance transformation ratio for each element. Still, the antenna need only be connected at two points, at the ground point 43 and at the feed connection 47, which both are fixed, and common for the two frequencies.

The same technique can be used for connecting and adapting three or more meander elements of multi-frequency antennas. A disadvantage of using multiple meanders is that each meander will be unnecessary small (assuming a given total area) as compared to the embodiments described below in which a single meander is used for more than one frequency band.

35

A single straight line or a meander with constant pitch, grounded at one end and open at the other, will basically have resonances related as 1:3:5, etc. By using a meander element with a variable pitch or combined with a straight line, as shown in Figure 5, these relations can be modified to 1:2,4 (AMPS/PCS), or 1:2 (GSM 900/1800). The meander element 50 of Figure 5 is arranged on a carrier 51 and grounded at point 52. A main feed line 53 connects a common feed connection 54 to a plurality of feed branches 55. Some of the feed branches comprises suitable capacitances and/or inductances 56. By cutting the feed branches at selected positions, as indicated by the circles 57, for instance, a desired feed point can be chosen, and a desired impedance can be connected to the antenna element in order to facilitate the matching of the impedance level over the frequency bands.

Some tuning stubs 58 are added to the basic antenna blank which stubs can be cut as desired, as indicated by the circles 59, for fine frequency tuning of the band frequencies.

Figure 6 shows an embodiment in which another technique is used to obtain two- or three-band performance using one meander element 60 only. This is obtained by connecting a resonant circuit to the far end of the meander 60 which converts the $\lambda/4$ function at one frequency band to a $\lambda/2$ function at a higher frequency band.

The resonant circuit is a series resonant circuit comprising the inductance of an additional short meander pattern 61 which forms a coupling capacitor 62 with the antenna meander element 60. The short meander pattern 61 is grounded at a point 63. For a typical case the complete antenna element can have resonance

frequencies related as 1:2 (900 and 1800 MHz, for instance), and will have a similar amplitude pattern over the element for both frequencies. This will increase the antenna efficiency at the higher frequency band, and make this band broader.

The operation of the series resonant circuit 61, 62 is the following.

At the resonance frequency of the series resonant circuit this circuit will act almost as a short circuit, and connect the far end of the meander element 60 directly to ground at point 63. This will correspond to the $\lambda/2$ operation, i.e. the electrical length of the element 60 will be $\lambda/2$.

At half that frequency the series resonant circuit 61, 62 will represent an open circuit, and the meander element 60 will act as an open ended element, i.e. its electrical length at that frequency will be $\lambda/4$.

The frequency tuning of the meander elements 60 and 61 can be adjusted by shortening the lengths thereof by cutting away end portions, as indicated by the circles 64, 65, for instance. The coupling capacitance 62 can also be designed to be adjustable by removing conductive material, and have the form of interleaved "fingers", for instance.

The antenna element 60 is fed via a feed line 66, and the grounding to a ground point 67 is obtained over a "grounding capacitor" 68. This capacitor can be made by conductors close to each other or, if the PCB of the phone is two-sided, by partly overlapping conductors on the different sides of the PCB. The feed line 66 can be connected to a number of selectable feed points, as

described in connection with Figure 5.

In Figure 7 a patch antenna blank modified for double
tuning is shown. In this case the patch comprises two
5 main portions 70, 71, and a middle portion 72 with
meander form in order to shorten or shrink the patch to
make the patch resonant in the typically case when the
physical length of the patch is smaller than half a
wavelength. Depending on size and frequency a common
10 straight patch can also be used.

The patch is provided with stubs 73 portions of which
can be cut away, as indicated by the circles 74, for
instance. Hereby the frequency tuning can be adjusted.
15 The impedance of the antenna element can be adapted as
required by selecting one of a plurality of feed points
75, as has been described in connection with Figure 5,
for instance. Reference numeral 78 is the feed line.

20 A ground point 76 is connected to the middle of the
meander shaped portion 72 of the patch by means of a
ground connection line 77.

Figure 8 shows a slot antenna, i.e. a conductive patch
25 80 provided with two slots 81, 82. For this antenna a
common patch feeding technique can be used. Alternati-
vely one can use a double sided pattern, i.e. the patch
80 with its slots 81, 82 is arranged on one side of a
carrier 83, and a feed line 84 is arranged on the
30 opposite side, and connected to a feed element 85. The
patch is grounded at its center, by means of a ground
line 89, where also the feed line 84 to one or both of
the slots is entering.

35 The tuning and impedance of this antenna element can be
adjusted by cutting away portions of stubs 86, as

indicated by circles 87, for instance, and by altering the shapes of the slots 81, 82 by removing material by punching, as indicated by the circles 88, for instance. The slots will lower the resonance frequency as compared to a patch of the same size without slots.

In all patterns discussed above a double tuning can be used to increase the bandwidth. One example is illustrated in Figure 9. Like the antenna blank of Figure 4 the antenna pattern comprises two parallel meander shaped elements 90, 91 for a lower and a higher band, respectively. For tuning purposes the length of each element 90, 91 can be adjusted, as indicated by the circles 92, for instance. The antenna elements 90, 91 are connected to a common ground point 93 over a "grounding capacitor" 94.

To provide the double tuning option the antenna elements 90, 91 are fed via a series resonant circuit comprising the inductance of a meander 95, and a coupling capacitance 96. The resonant circuit is suitably optimized for the lower band (where the bandwidth is most scarce), but it will be of some use at the higher band as well.

As is realized by the person skilled in the art the added tuning circuit can be varied in several respects, and may comprise discrete components as well.

All of the discussed antenna patterns can be combined with an extendable whip antenna element. This can be fitted with some tuning components of its own to improve its performance. Figure 10 illustrates a meander element 100 of the general kind described above, and which has a capacitive whip connection 101. However, the whip can be galvanically connected to the meander

as well.

As can be understood from the examples given above the invention comprises a method for adoption of an antenna blank to different phones or other apparatus, and hardware features relating to the design of the antenna blank. The object of the method is to "translate" features of the phone into corresponding modifications of the blank. The design of the antenna blank should enable easily performed modifications of the blank to fulfil different matching needs, primarily tuning and adjustments of the impedance level. Preferably, the blank should be designed to allow independent adjustments of the tuning and the impedance level. The tuning is only slightly depending on the amount of dielectric material, etc. around the antenna element, but due to the inherent narrow bandwidth of a small antenna element the tuning is still important. The size and location of the antenna element on the other hand are very important for the impedance level, and thus it is very important that the antenna blank allows adjustments of the impedance level within a wide range.

In the embodiments above tuning and impedance adjustments have been carried out by cutting or breaking connections, disconnecting components, or removing conductive materials. Alternatively, the same results can be obtained by making connections, connecting components, or adding conductive material. This can be carried out by adding conductive material at selected positions in the antenna pattern, for instance by applying an electrically conductive dye or ink by means of an ink-jet printer. However, electrical connections can be made, and electrical conductive material can be applied in many other ways as well.

CLAIMS

1. A method for manufacturing antenna devices for transmitting and receiving RF waves and having antenna properties adapted to suit a specific model of a radio communication device, characterized by
- 5
- 10 - providing a standard antenna blank having a form enabling the blank to be arranged in a plurality of different models of a radio communication device, and which blank at a plurality of predetermined positions being prepared to be modifiable in order to enable its antenna properties to be adapted to suit anyone of said plurality of models,
 - 15 - determining at least one physical parameter of said specific model of a radio communication device,
 - 20 - using said at least one physical parameter to decide on suitable modifications of the standard antenna blank,
 - 25 - effecting the decided modifications of the antenna blank by carrying out at least one of the following operations: making disruptions in electrically conducting paths of the antenna blank, electrically interconnecting conductive parts of the antenna blank, removing electrically conductive material from the antenna blank, and adding electrically conductive material to the antenna blank, and
 - 30
 - 35 - using the obtained modified antenna element as a templet for the manufacturing of antenna devices

for other radio communication devices of the same model by effecting corresponding modifications of prefabricated standard antenna blanks of the same kind.

5

2. A method according to claim 1, characterized by

10 - using a standard antenna blank which is modifiable into any one of a plurality of antenna configuration states, each corresponding to a specific model of said plurality of different models of a radio communication device, and

15 - modifying the standard antenna blank into one of these antenna configuration states in dependence on the physical parameter determined for the model of radio communication device in which the antenna device is to be arranged.

20 3. A method according to claim 1 or 2, characterized by

25 - using as said at least one physical parameter the size of the radiating surface of the body of the radio communication device in which the antenna device is to be arranged.

4. A method according to any of claims 1-3, characterized by

30

- modifying the input impedance of the standard antenna blank by selecting at least one of a plurality of feed connections, or at least one of a plurality of ground connections by severing the non-selected ones from the antenna blank.

35

5. A method according to any of claims 1-4, characterized by

- 5 - modifying the antenna blank by disconnecting at least one electrical component from the antenna blank or connecting at least one electrical component to the antenna blank.

10 6. A method according to any of claims 1-5, characterized by

- 15 - modifying the antenna blank by making a severing cut in a conductive path forming a short circuit between two points of the antenna blank.

15 7. A method according to any of claims 1-6, characterized by

- 20 - modifying the standard antenna blank by removing conductive material therefrom by punching, or by means of a laser beam.

25 8. A method according to any of claims 1-7, characterized by

- 25 - modifying the standard antenna blank by adding electrically conductive material to the antenna blank.

30 9. A method according to any of claims 1-8, characterized by

- 35 - modifying the standard antenna blank by adding an electrically conductive material by applying an electrically conductive dye or ink to the antenna blank.

10. A method according to claim 9, characterized by

- applying said conductive ink by means of an ink-jet printer.

5

11. An antenna device manufactured according to any of claims 1-10.

10 12. An antenna blank for use in the manufacturing of antenna devices for transmitting and receiving RF waves and having antenna properties adapted to suit a specific model of a radio communication device,

15 characterized by

- said antenna blank being a prefabricated standard antenna blank having a form enabling the blank to be arranged in a plurality of different models of a radio communication device,

20

- said antenna blank at a plurality of predetermined positions (7, 10, 11, 12) being prepared to be modifiable in order to enable its antenna properties to be adapted to suit anyone of said plurality of models, and

25

- the design of the standard antenna blank being such that the modification of the antenna properties can be effected by carrying out at least one of the following operations: making disruptions in electrically conducting paths of the antenna blank, electrically interconnecting conductive parts of the antenna blank, removing electrically conductive material from the antenna blank, and adding electrically conductive materi-

30

35

al to the antenna blank.

13. A blank according to claim 12,
- 5 - comprising a plurality of spaced feed points, and
wherein
- said feed points are connected to a common feed
connection (47; 54) via severable feed lines (48,
10 49; 55).
14. A blank according to claim 12 or 13,
- comprising a plurality of spaced ground points,
15 and wherein
- said ground points are connected to a common
ground connection via severable ground lines.
- 20 15. A blank according to any of claims 12-14,
- comprising at least one radiating element (50;
60) tunable for operation in at least two fre-
quency bands by carrying out at least one of said
25 operations.
16. A blank according to claim 15, wherein
- said radiating element (50; 60) is indepently
30 tunable in a lower frequency band, and in a
higher frequency band, the frequency of the
higher band being approximately double the fre-
quency of the lower band.
- 35 17. A blank according to claim 16, wherein

- the radiating element (60) has a first and a second end, and is fitted with a selectable feed connection (66) near said first end,
- 5 - a frequency dependent impedance (61, 62) is coupled to said second end,
 - said impedance acting as a short circuit between
10 said second end of the radiating element (60) and ground at the higher frequency band, and as an open end of the radiating element (60) at the lower frequency band.
- 15 18. A blank according to claim 17, wherein
 - said frequency dependent impedance (61, 62) comprises a series resonant circuit, the resonance frequency of which corresponds approximately to the frequency of said higher frequency band.
- 20 19. A blank according to claim 18, wherein
 - the inductance (61) of said series resonant circuit is provided by a short meander shaped strip
25 or wire, and
 - the capacitance (62) of said series resonant circuit is constituted by a coupling capacitance between said meander shaped strip or wire, and
30 the radiating element (60).
- 35 20. A blank according to any of claims 12-19, comprising
 - at least two radiating elements (40, 41), wherein

- each element (40, 41) is tunable for operation in at least one frequency band by carrying out at least one of said operations, and
- 5
- the input impedance of each element being individually adjustable by selecting an appropriate feed point.
21. A blank according to any of claims 12-20, comprising
- 10
- at least one radiating element (40, 41; 50; 60) having a first end and a second end,
- 15
- said first end being connectable to ground (43; 52; 67) via a low impedance, and
 - the radiating element having a plurality of selectable feed points near said first end.
- 20
22. A blank according to claim 21, comprising
- at least two radiating elements (40, 41), and a common feed connection (47), wherein
- 25
- each element (40, 41) has a plurality of feed points which can be selectively connected to the common feed connection (47) in order to obtain essentially the same input impedance level for
- 30
- all radiating elements (40, 41).
23. A blank according to claim 21 or 22, wherein
- said first end of a respective radiating element
- 35
- (40, 41; 50) is galvanically connectable to ground (43; 52).

24. A blank according to claim 21 or 22, wherein
- 5 - said first end of a respective radiating element (60) is connectable to ground (67) via an impedance having a low impedance for the frequency band in which the element is intended to operate.
25. A blank according to claim 24, wherein
- 10 - said impedance comprises a capacitor (68).
26. A blank according to any of claims 12-25, wherein
- 15 - a series resonant circuit (95, 96) being coupled to an input end of at least one radiating element (90, 91) in order to broaden the frequency band of said radiating element.
27. A blank according to any of claims 12-26,
- 20 - comprising a radiating element in the form of at least one planar conductive strip (1) or wire.
28. A blank according to claim 27, wherein
- 25 - the conductive strip (1) or wire includes a meander shape.
29. A blank according to any of claims 12-28,
- 30 - comprising a radiating element in the form of at least one conductive patch (70, 71, 72).
30. A blank according to any of claims 12-29,
- 35

- comprising a radiating element including at least one slot (80, 81, 82).

5 31. A blank according to any of claims 12-30, which includes electrical components (56) which can be disconnected from or connected to an antenna element of the blank.

10 32. A radio communication device, comprising an antenna device manufactured from an antenna blank according to any of claims 12-31.

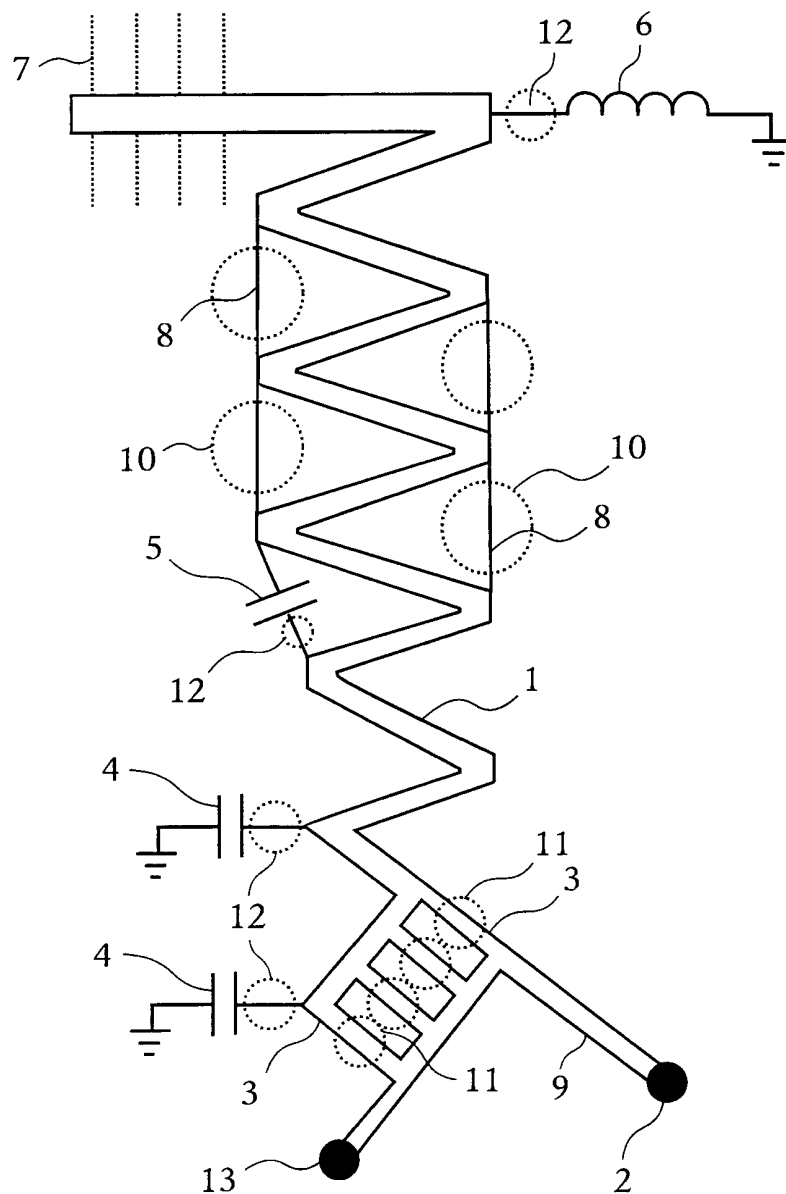

Fig. 1

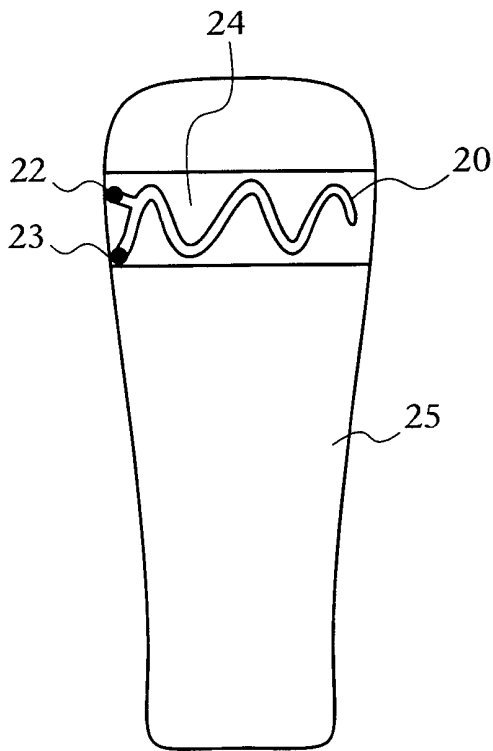

Fig. 2a

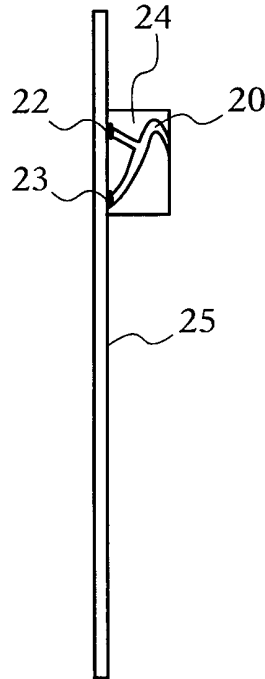

Fig. 2c

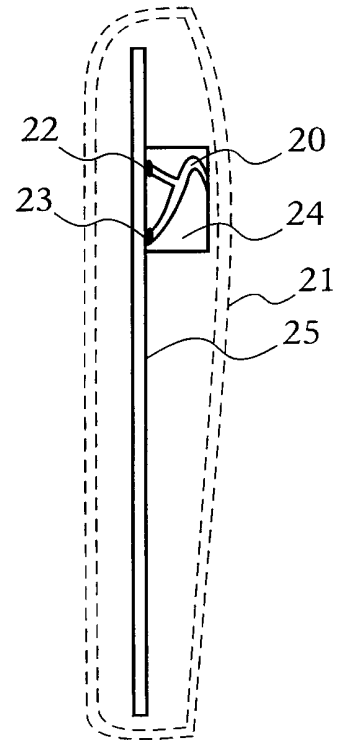

Fig. 2d

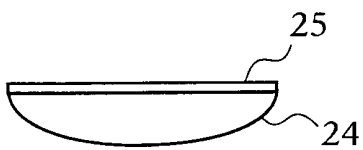

Fig. 2b

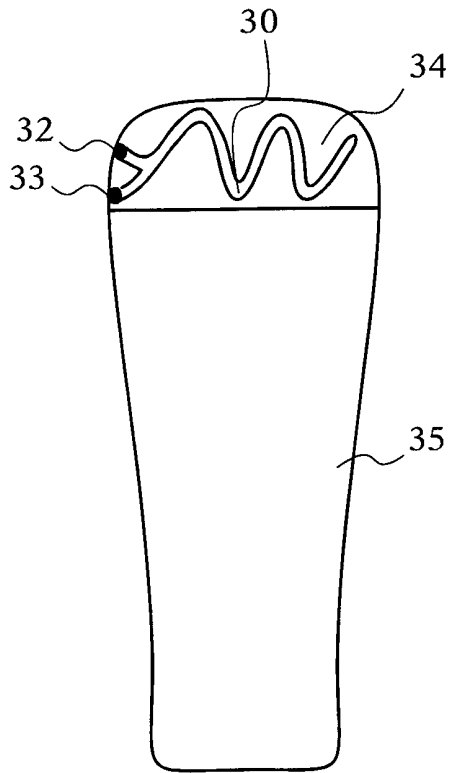

Fig. 3a

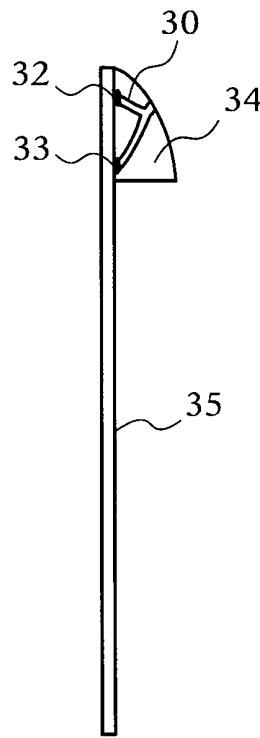

Fig. 3b

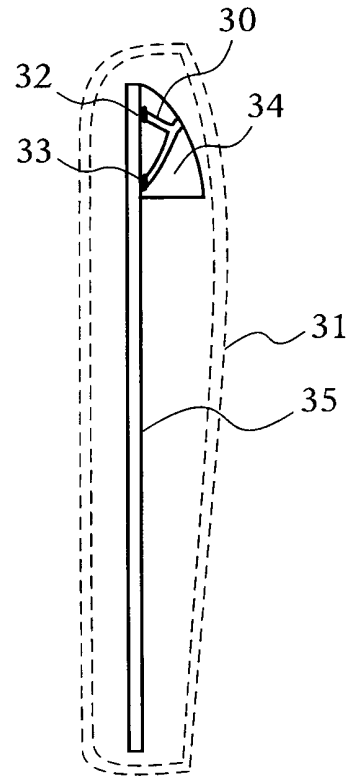

Fig. 3c

4/7

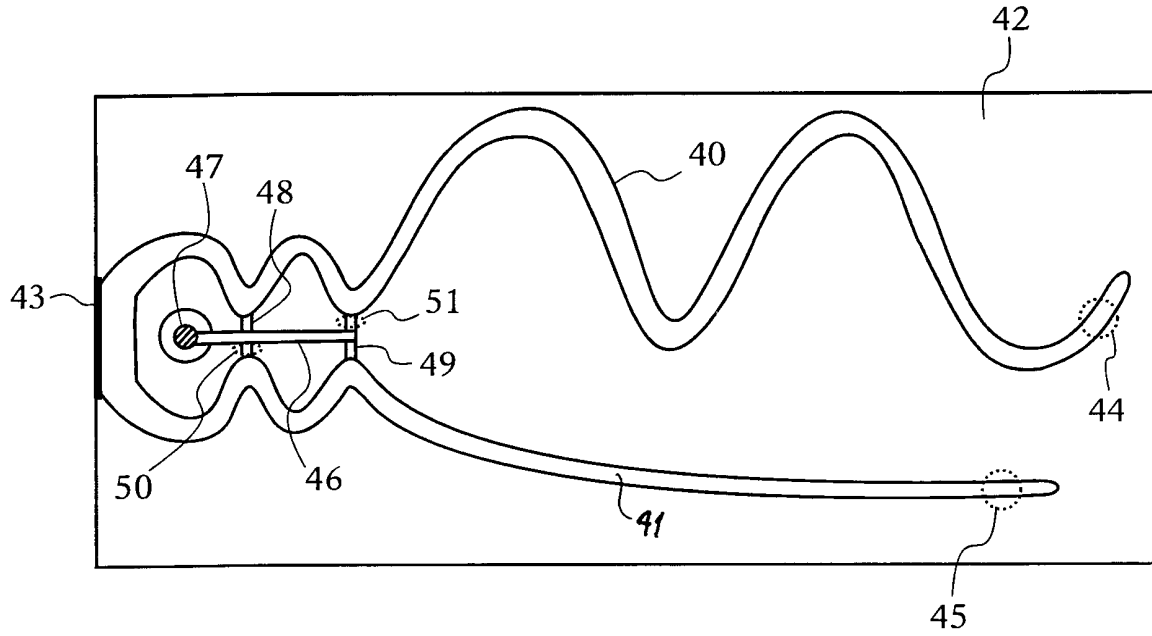

Fig. 4

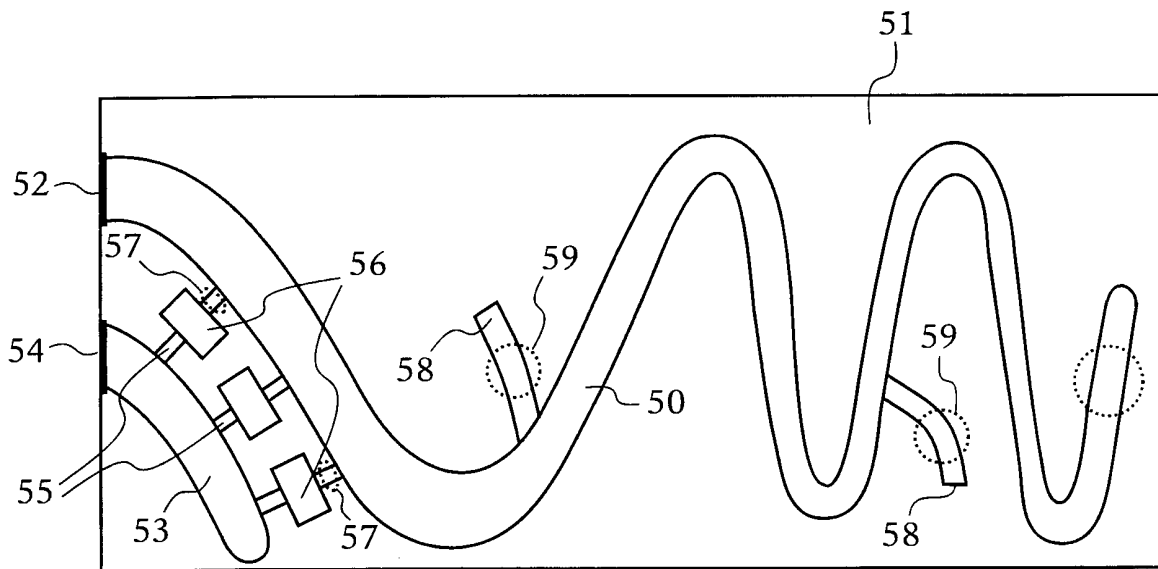

Fig. 5

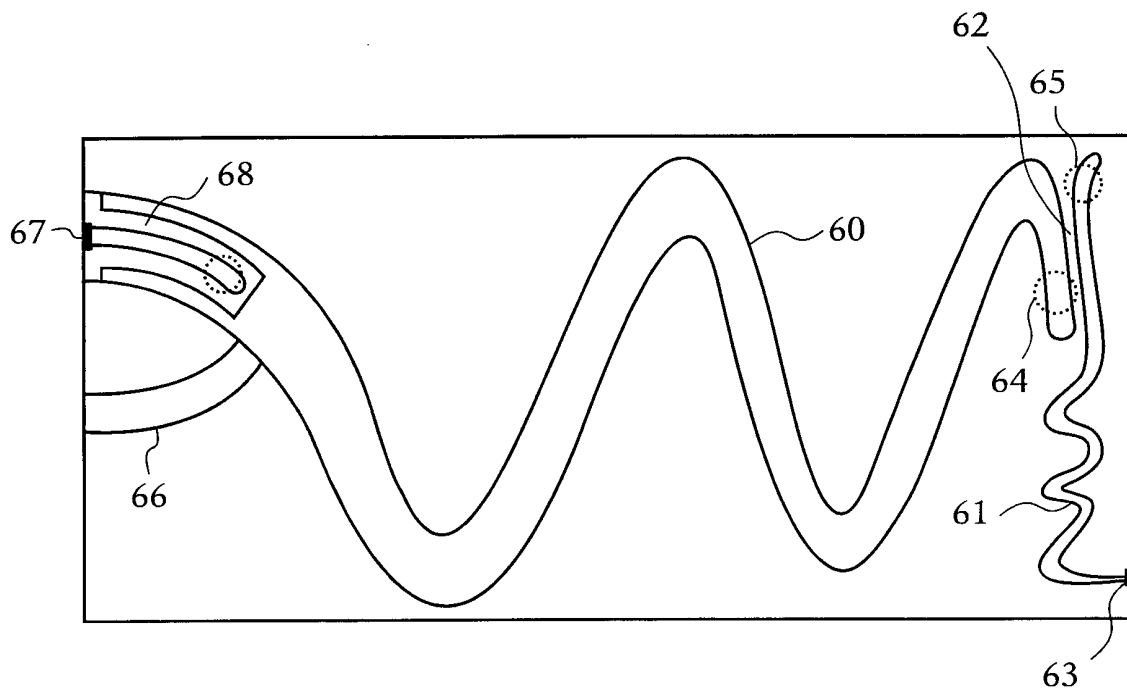

Fig. 6

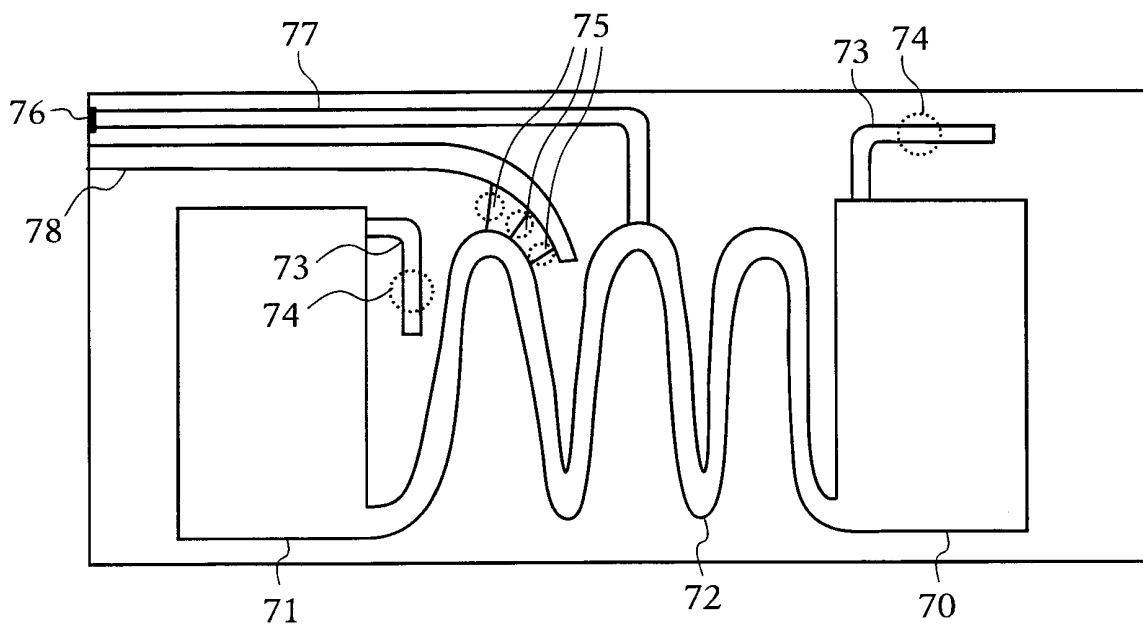

Fig. 7

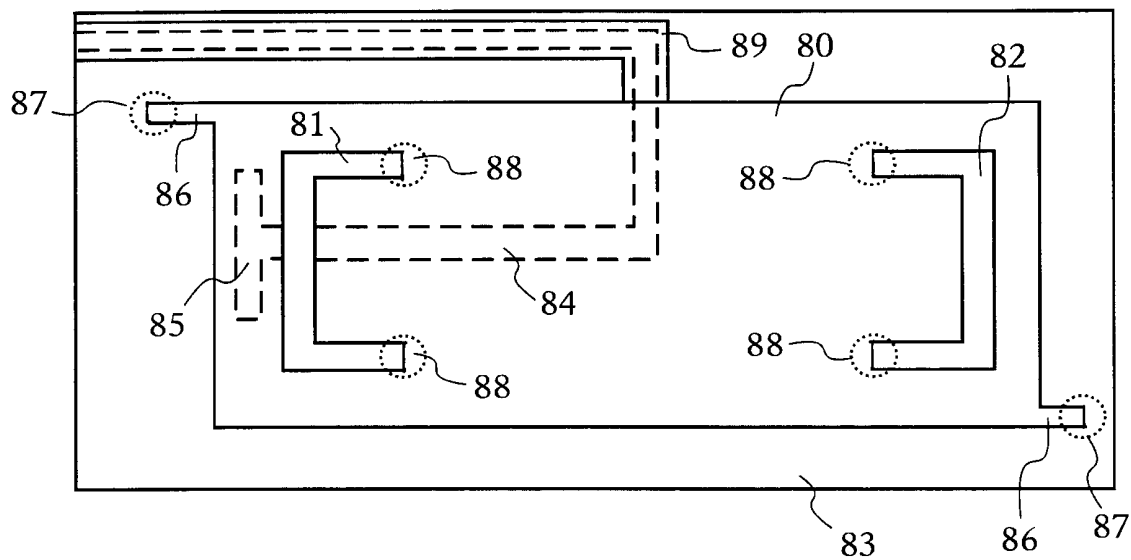

Fig. 8

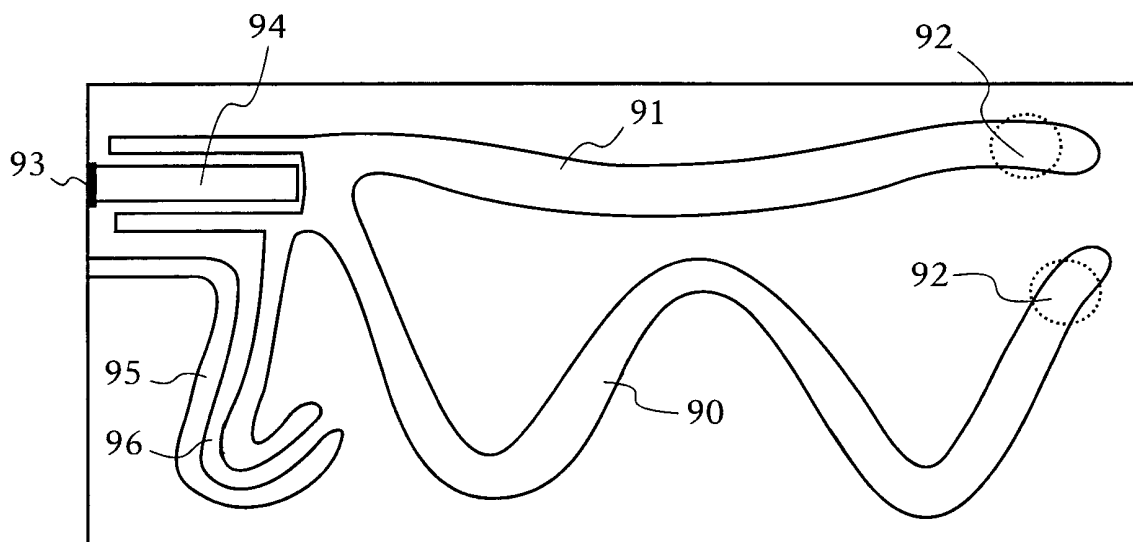

Fig. 9

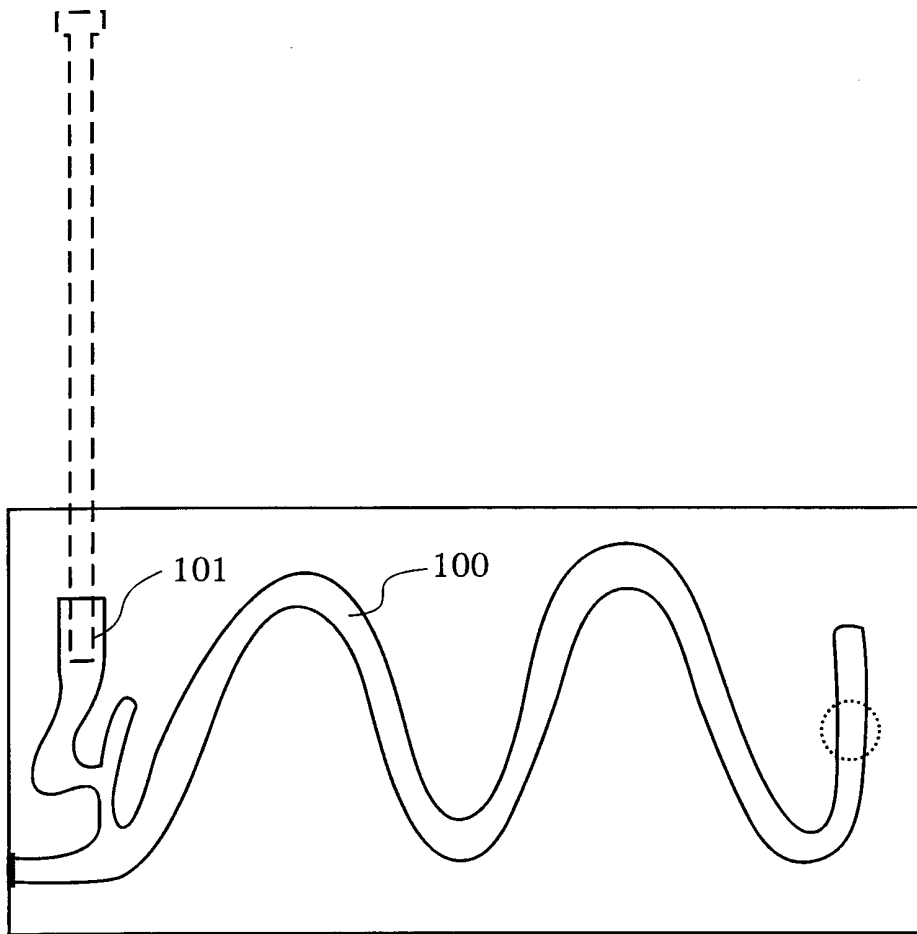

Fig. 10

INTERNATIONAL SEARCH REPORT

International application No.
PCT/SE 00/02534

A. CLASSIFICATION OF SUBJECT MATTER

IPC7: H01Q 1/24

According to International Patent Classification (IPC) or to both national classification and IPC

B. FIELDS SEARCHED

Minimum documentation searched (classification system followed by classification symbols)

IPC7: H01Q

Documentation searched other than minimum documentation to the extent that such documents are included in the fields searched

SE,DK,FI,NO classes as above

Electronic data base consulted during the international search (name of data base and, where practicable, search terms used)

C. DOCUMENTS CONSIDERED TO BE RELEVANT

Category*	Citation of document, with indication, where appropriate, of the relevant passages	Relevant to claim No.
A	WO 9922420 A1 (TELEFONAKTIEBOLAGET LM ERICSSON), 6 May 1999 (06.05.99), abstract --	1-32
A	WO 9952175 A1 (ALLGON AB), 14 October 1999 (14.10.99), abstract --	1-32
A	WO 9956345 A1 (INTENNA TECHNOLOGY AB), 4 November 1999 (04.11.99), abstract -- -----	1-32

 Further documents are listed in the continuation of Box C.
 See patent family annex.

* Special categories of cited documents:	"I" later document published after the international filing date or priority date and not in conflict with the application but cited to understand the principle or theory underlying the invention
"A" document defining the general state of the art which is not considered to be of particular relevance	"X" document of particular relevance: the claimed invention cannot be considered novel or cannot be considered to involve an inventive step when the document is taken alone
"E" earlier application or patent but published on or after the international filing date	"Y" document of particular relevance: the claimed invention cannot be considered to involve an inventive step when the document is combined with one or more other such documents, such combination being obvious to a person skilled in the art
"L" document which may throw doubts on priority claim(s) or which is cited to establish the publication date of another citation or other special reason (as specified)	"&" document member of the same patent family
"O" document referring to an oral disclosure, use, exhibition or other means	
"P" document published prior to the international filing date but later than the priority date claimed	

Date of the actual completion of the international search 14 March 2001	Date of mailing of the international search report 30-03-2001
Name and mailing address of the ISA/ Swedish Patent Office Box 5055, S-102 42 STOCKHOLM Facsimile No. +46 8 666 02 86	Authorized officer Rune Bengtsson/BS Telephone No. +46 8 782 25 00

INTERNATIONAL SEARCH REPORT

Information on patent family members

25/02/01

International application No.

PCT/SE 00/02534

Patent document cited in search report	Publication date	Patent family member(s)	Publication date
WO 9922420 A1	06/05/99	AU 9657998 A EP 1025613 A TW 392376 B	17/05/99 09/08/00 00/00/00
WO 9952175 A1	14/10/99	AU 3963499 A AU 7948898 A EP 0997008 A GB 0020066 D GB 2349983 A SE 512127 C SE 9801169 A SE 9804498 D	25/10/99 04/01/99 03/05/00 00/00/00 15/11/00 31/01/00 03/10/99 00/00/00
WO 9956345 A1	04/11/99	AU 4300299 A AU 8566198 A EP 1012996 A SE 513055 C SE 9801447 A	16/11/99 29/03/99 28/06/00 26/06/00 25/10/99