

(12) PATENT
(19) AUSTRALIAN PATENT OFFICE

(11) Application No. AU 199742284 B2
(10) Patent No. 706153

(54) Title
Improved time delay ignition circuit for an internal combustion engine

(51)⁶ International Patent Classification(s)
F02P 009/00

(21) Application No: **199742284**

(22) Application Date: **1997.06.20**

(87) WIPO No: **WO97/48903**

(30) Priority Data

(31) Number	(32) Date	(33) Country
60/020032	1996.06.21	US

(43) Publication Date : **1998.01.07**

(43) Publication Journal Date : **1998.03.05**

(44) Accepted Journal Date : **1999.06.10**

(71) Applicant(s)
Ficht GmbH and Co. KG

(72) Inventor(s)
Wolfram Hellmich; Todd D Craft; Gregory J. Binversie; Philip J. Bylsma

(74) Agent/Attorney
PHILLIPS ORMONDE and FITZPATRICK,367 Collins Street,MELBOURNE VIC 3000

(56) Related Art
US 3892207

US 4111178



INT

(51) International Patent Classification⁶ : F02P 9/00 SEARCH QUALITY ASSURANCE		A2	(11) International Publication Number: WO 97/48903
			(43) International Publication Date: 24 December 1997 (24.12.97)
(21) International Application Number: PCT/US97/10636	(81) Designated States: AL, AM, AU, BA, BB, BG, BR, CA, CN, CU, CZ, EE, GE, GH, HU, IL, IS, JP, KP, KR, LC, LK, LR, LT, LV, MG, MK, MN, MX, NO, NZ, PL, RO, RU, SG, SI, SK, SL, TR, TT, UA, US, UZ, VN, YU, ZW, ARIPO patent (GH, KE, LS, MW, SD, SZ, UG, ZW), Eurasian patent (AM, AZ, BY, KG, KZ, MD, RU, TJ, TM), European patent (AT, BE, CH, DE, DK, ES, FI, FR, GB, GR, IE, IT, LU, MC, NL, PT, SE), OAPI patent (BF, BJ, CF, CG, CI, CM, GA, GN, ML, MR, NE, SN, TD, TG).		
(22) International Filing Date: 20 June 1997 (20.06.97)			
(30) Priority Data: 60/020,032 21 June 1996 (21.06.96) US			
(71) Applicant (for all designated States except US): FICHT GMBH & CO. KG [DE/DE]; Spannleitenberg 1, D-85614 Kirchseeon (DE).			
(72) Inventors; and			
(75) Inventors/Applicants (for US only): HELLMICH, Wolfram [DE/DE]; Westermeierstrasse 31, D-81829 München (DE). CRAFT, Todd, D. [US/US]; 3608 125th Street, Kenosha, WI 53142 (US). BINVERSIE, Gregory, J. [US/US]; 162 Prairieview Avenue, Grayslake, IL 60030 (US). BYLSMA, Philip, J. [US/US]; 3380 Burlawn Parkway, Brookfield, WI 53005 (US).			
(74) Agents: SANDLER, Ronald, A. et al.; Jones, Day, Reavis & Pogue, 77 West Wacker Drive, Chicago, IL 60601-1692 (US).			

Published
Without international search report and to be republished upon receipt of that report.

(54) Title: IMPROVED TIME DELAY IGNITION CIRCUIT FOR AN INTERNAL COMBUSTION ENGINE

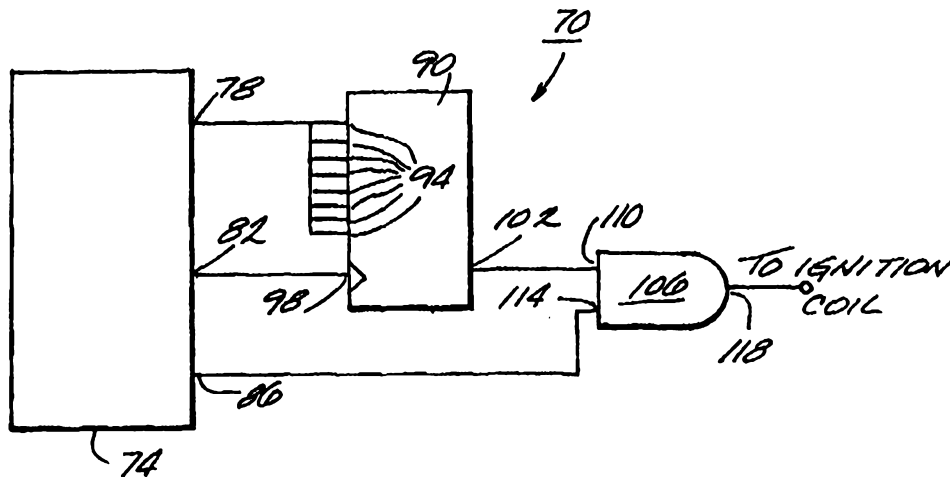

(57) Abstract

An internal combustion engine assembly including an internal combustion engine including an engine block having at least one cylinder, a piston mounted within the cylinder for reciprocal movement in the cylinder, a fuel injector for injecting fuel into the cylinder, the fuel injector initiating a fuel injection event at a predetermined time and a circuit for generating a spark in the cylinder a predetermined amount of time after the injection event to cause combustion of fuel in the cylinder.

IMPROVED TIME DELAY IGNITION CIRCUIT FOR AN INTERNAL COMBUSTION ENGINE

5 CROSS-REFERENCES TO RELATED APPLICATIONS

This application claims the benefit of U.S. provisional application serial number 60/020,032, filed June 21, 1996.

Attention is directed to United States patent application serial no. 08/507,664, filed July 25, 1995.

10

BACKGROUND OF THE INVENTION

The invention relates to an internal combustion engine, and particularly to an ignition timing circuit for an internal combustion engine.

15 Spark-ignited internal combustion engines require a spark at the spark plug in order to ignite the fuel and air mixture in the cylinder of the engine. The timing of the combustion event is critical in the operation of the internal combustion engine. Particularly, the timing of the combustion event controls the speed and acceleration of the engine as well as the efficiency with which the fuel
20 in the cylinder is burned. Various methods of timing the combustion event are known. In particular, it is generally known to make use of various engine operating parameters to time the combustion event. Such parameters may include crankshaft angle, engine temperature and/or cylinder pressure.

25 SUMMARY OF THE INVENTION

In the case of an internal combustion engine utilizing fuel injectors, the air/fuel mixture is atomized into a "stratified" fuel/air cloud that "floats" from the injector nozzle in the cylinder toward the spark gap at the spark plug. If the
30 ignition spark jumps the spark gap before the fuel/air cloud reaches the spark gap, the fuel/air cloud will not be completely burned. In order to assure that complete combustion of the stratified fuel/air cloud is attained, it is necessary to time the ignition spark for the precise moment when the fuel/air cloud reaches the spark gap.

Accordingly, this invention provides an absolute time delay ignition circuit for an internal combustion engine. The time delay ignition circuit bases the timing of the ignition spark on the elapsed time from the fuel injector event. That is, the electronic control unit of the engine generates a signal causing
5 injection of fuel by the fuel injector and subsequently generates a signal causing an ignition spark based on an absolute period of elapsed time measured from the injection signal. The electronic control unit can generate the time delay based upon either a fixed calibrated time period, a predetermined time period stored in a memory based look-up table, or a time period calculated from a software based
10 algorithm that evaluates various parameters such as temperature, pressure, etc.

In one embodiment, the engine is operated with time-based ignition at low speeds, and is operated with crank-angle-based ignition at high speeds, i.e., the change from time-based ignition to crank-angle-based ignition is based solely on engine speed. In another embodiment, the engine is operated with time-based
15 ignition at low engine loads (as measured by throttle position), and is operated with crank-angle-based ignition at high engine loads, i.e., the change from time-based ignition to crank-angle-based ignition is based solely on engine loads. In another embodiment, the engine is operated with time-based ignition at low loads and low speed, and is operated with crank-angle-based ignition at either high
20 loads or high speeds, i.e., the change from time-based ignition to crank-angle-based ignition is based on both the engine speed and engine load.

The invention also provides an internal combustion engine assembly comprising: an internal combustion engine including an engine block having at least one cylinder; a piston mounted within the cylinder for reciprocal movement
25 in the cylinder; a fuel injector for injecting fuel into the cylinder; and circuit means for generating an injection control signal indicative of a fuel injection event and for generating a spark in the cylinder a predetermined amount of time after generation of the injection control signal.



The circuit means desirably includes a timer for measuring the time elapsed since generation of the injection control signal and generating a timing signal corresponding to the elapsed time, and means responsive solely to the timing signal for generating a spark within the cylinder.

5 The invention also provides an internal combustion engine assembly comprising: an internal combustion engine including an engine block having at least one cylinder; a piston mounted within the cylinder for reciprocal movement in the cylinder; a fuel injector for injecting fuel into the cylinder; and a circuit for generating an injection control signal indicative of a fuel injection event, the
10 circuit including a timer having a timer output for generating an electrical timing signal, the timing signal having a predetermined duration indicating an amount of time elapsed from generation of the injection control signal.

 The invention also provides a method of timing the ignition of fuel in an internal combustion engine, the engine including an engine block having at
15 least one cylinder, a piston mounted within the cylinder for reciprocal movement in the cylinder, a fuel injector for injecting fuel into the cylinder, the method comprising the steps of: (A) initiating an injection event; and (B) generating an ignition signal solely in response to the time elapsed since the injection event.

 The step (B) desirably includes:
20 measuring the time elapsed since generation of the injection control signal and generating a timing signal corresponding to the elapsed time;
 generating a spark signal; and
 generating an ignition current in the cylinder solely as determined by the occurrence of the timing signal and the spark signal.

25 It is an advantage of the invention to provide an ignition system that bases the timing of the ignition spark on an absolute period of time measured from the fuel injection event.

 It is another advantage of the invention to provide an ignition timing system allowing operation of the engine at idling speeds of less than 200
30 rotations of the crankshaft per minute.

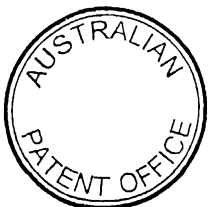

It is another advantage of the invention to provide an ignition timing system that causes efficient and complete combustion of the fuel/air cloud in the cylinder.

5 It is another advantage of the invention to provide an ignition timing system that is resistant to minor engine speed fluctuations.

Other features and advantages of the invention are set forth in the following detail description and claims.

BRIEF DESCRIPTION OF THE DRAWINGS

10

These and other features of the present invention will be more fully disclosed when taken in conjunction with the following DETAILED DESCRIPTION OF THE PREFERRED EMBODIMENT(S) in which like numerals represent like elements and in which:

15

FIG. 1 is a partial cross section of an internal combustion engine embodying the invention;

FIG. 2 is an electrical schematic of the time delay ignition circuit for an internal combustion engine having a single cylinder;

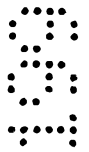
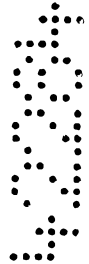

FIG. 3 is a time chart illustrating the time-based relationships between various electronic signals in the time delay ignition circuit;

FIG. 4 is an electrical schematic illustrating a time delay ignition circuit for use in connection with an internal combustion engine having six
5 cylinders;

FIG. 5 is a chart illustrating injection timing for the engine of FIG. 4 as measured in degrees before top-dead-center (DBTDC) and plotted as a function of engine speed and throttle position;

FIG. 6 is a chart illustrating ignition timing for the engine of FIG. 4 as
10 measured in DBTDC and plotted as a function of engine speed and throttle position;

FIG. 7 is a chart illustrating the maximum ignition coil on time for the engine of FIG. 4 as measured in milliseconds (ms) and plotted as a function of engine speed;

FIG. 8 is a chart illustrating the ignition coil on time for the engine of
15 FIG. 4 as measured in milliseconds (ms) and plotted as a function of engine speed and throttle position;

FIG. 9 is a chart illustrating the injection pulse time for the engine of
20 FIG. 4 as measured in milliseconds (ms) and plotted as a function of engine speed and throttle position; and

FIG. 10 is a graph showing the transition from time-based ignition to crank-angle-based ignition in the engine of FIG. 4.

Before one embodiment of the invention is explained in detail, it is to be understood that the invention is not limited in its application to the details of
25 construction and the arrangement of components set forth in the following description or illustrated in the drawings. The invention is capable of other embodiments and of being practiced or carried out in various ways. Also, it is to be understood that the phraseology and terminology used herein is for the purpose of description and should not be regarded as limiting.

DETAILED DESCRIPTION OF THE PREFERRED EMBODIMENT(S)

Partially shown in FIG. 1 of the drawings is an internal combustion engine 10. One cylinder 14 of the engine 10 is illustrated in FIG. 1. The engine 10 includes a crankcase 18 defining a crankcase chamber 22 and having a crankshaft 26 rotatable therein. An engine block 30 defines the cylinder 14. The engine block 30 also defines an intake port 34 communicating between the cylinder 14 and the crankcase chamber 22 via a transfer passage 38. The engine block 30 also defines an exhaust port 42. A piston 46 is reciprocally moveable in the cylinder 14 and is drivingly connected to the crankshaft 26 by a connecting rod and crank pin assembly 50. A cylinder head 54 closes the upper end of the cylinder 14 so as to define a combustion chamber 58. The engine 10 also includes a fuel injector 62 mounted on the cylinder head 54 for injecting fuel into the combustion chamber 58. A spark plug 66 is mounted on the cylinder head 54 and extends into the combustion chamber 58.

The internal combustion engine 10 also includes (see FIG. 2) a time delay ignition circuit 70 for generating a spark in the cylinder 14 at a predetermined moment after the injection of fuel into the combustion chamber 58 has occurred. As shown in FIG. 2, the time delay ignition circuit 70 includes a microprocessor 74 having data outputs 78, an injection indicator output 82, and a spark generating output 86. As described below, the microprocessor 74 generates spark signals at the output 86. It should be understood, however, that the spark signals may be generated by another appropriate component such as an ECU. The circuit 70 also includes a timer 90 having an 8-bit register of data inputs 94 for receiving timing information from the data outputs 78 of the microprocessor 74. The timer 90 also has a trigger input 98 connected to the injection indicator output 82 of the microprocessor 74 to receive from the microprocessor 74 a signal indicating when an injection event has been initiated by the microprocessor 74. The timer 90 also includes a timing pulse output 102.

The time delay ignition circuit 70 also includes an AND gate 106 having two inputs 110 and 114 and an output 118. Input 110 of AND gate 106 is connected to the output 102 of the timer 90. Input 114 of AND gate 106 is connected to

-6-

the microprocessor 74 to receive from the microprocessor 74 a spark generating signal from spark generating output 86. The output 118 of the AND gate 106 is connected to an ignition coil 122 (shown schematically in FIG. 1) to generate a spark in the cylinder 14 and ignite the fuel in the cylinder 14.

5 In operation, when an injection event occurs, the timer 90 receives, from output 82 of microprocessor 74, and injection control signal (see reference numeral 2 in FIG. 3) at the trigger input 98 of timer 90 and, in response to the injection control signal, begins to count the clock pulses from the microprocessor clock signal. As long as the timer count has not expired, the timer 90 generates
10 at the output 102 a high signal or timing signal (see reference numeral 3 in FIG. 3). When the microprocessor 74 generates the spark signal at the output 86 (see reference numeral 4 in FIG. 3), and this spark signal is received at the input 114 to the AND gate 106, the AND gate 106 generates at output 118 an output or ignition signal or current which is transmitted to the ignition coil 122 (see
15 reference numeral 5 in FIG. 3). The output 118 goes low (see reference numeral 6 in FIG. 3) when the output 102 goes low (see reference numeral 7 in FIG. 3). While the output 118 is high, current flowing through the ignition coil rises. The output 102 goes low when the timer count received from the microprocessor has expired, causing the output 118 to go low, i.e., when the microprocessor 74
20 indicates that the desired amount of time has elapsed since the injection event. Because the current in an inductor or ignition coil cannot change instantaneously ($V = L(di/dt)$), the abrupt change in the current supply to the ignition coil causes the voltage on the ignition coil to quickly rise thereby generating a spark causing ignition of the fuel in the cylinder 14. In order to accommodate various sized
25 engines having various numbers of cylinders, the time delay ignition circuit 70 of FIG. 2 can be repeated as many times as there are cylinders.

While the ignition circuit 70 may be used at any speed, the ignition circuit 70 is preferably used at low or idle speeds, i.e., speeds of 200 to 2000 crankshaft rotations per minute (RPM), and has been shown to operate particularly well at
30 speeds as low as 200 RPM. At speeds above 2000 RPM, the engine is preferably controlled using a conventional crankshaft angle-based ignition system. In both conventional internal combustion engines and the internal combustion engine 10 shown in the drawings, timing of the spark generating signal at such speeds is

-7-

based solely on the crank angle of the crankshaft. However, in the prior art, the spark generating signal is connected directly to the ignition coil and initiates the ignition spark directly and without the need for any additional signals. The result is that the timing of prior art ignition events is dependent upon crank angle
5 rather than upon absolute time calculated from a fixed point in time. In contrast, the ignition circuit 70 causes ignition to always occur a predetermined amount of time after the injection event occurs, and this predetermined amount of time is not based on the crank angle of the crankshaft. The fuel injection event is the generation of the fuel injection signal at output 86 of microprocessor 74. This
10 may occur either at energization of the fuel injector or upon actual injection of the fuel into the cylinder 14.

FIG. 4 illustrates a time delay ignition circuit 200 for a six cylinder engine. Like parts are identified using like reference numerals. Rather than repeating the circuit 70 of FIG. 2 six times, the embodiment illustrated in FIG. 4 combines
15 (multiplexes) various signals to achieve some economy in the use of electronic components.

As shown in FIG. 4, the circuit 200 includes a timer 204 having an 8-bit data input register 208, three trigger inputs 212, 216, and 220 corresponding to cylinders one and four, two and five, and three and six, respectively, a clock input
20 224 and three outputs 228, 232, and 236 corresponding to trigger inputs 212, 216, and 220, respectively. The circuit 200 also includes OR gates 240, 244, and 248 having outputs 252, 256, and 260, respectively, which are connected to trigger inputs 212, 216, and 220, respectively. OR gates 240, 244, and 248 also include inputs 264 and 268, 272 and 276, and 280 and 284, respectively, connected to the
25 microprocessor 74 to receive injection output signals indicating that an injection event has occurred in a given cylinder. That is, the microprocessor generates output signals at outputs 288, 292, 296, 300, 304, and 308 to indicate that injection has occurred in cylinders one, two, five, three, and six, respectively.

The time delay ignition circuit 200 also includes AND gates 312, 316, and
30 320 having respective pairs of inputs 324, 328, and 332 connected to timer outputs 228, 232, and 236, respectively, and having respective outputs 336, 340, and 344. The time delay ignition circuit 200 also includes AND gate 348 having an input 352 connected to the output 336 of AND gate 312, an input 356 and an output

-8-

360; AND gate 364 having an input 368 connected to the output 340 of AND gate 316, an input 372 and an output 376; AND gate 380 having an input 384 connected to the output 344 of AND gate 320, an input 388 and an output 392; an AND gate 396 having an input 400 connected to the output 344 of AND gate 320, and input 404 and an output 408. Inputs 356 and 372 of AND gates 348 and 364, respectively, are connected to the microprocessor 74 to receive the spark signals from outputs 412 and 416, respectively, of microprocessor 74. In time delay ignition circuit 200, the spark signals from the microprocessor for cylinders one and four are multiplexed, i.e., combined, on output 412 and the spark signals for cylinders two and five are multiplexed on output 416. Inputs 388 and 404 of AND gates 380 and 396, respectively, are connected to the microprocessor 74 to receive the spark signals from outputs 420 and 424, respectively, of microprocessor 74. Output 420 generates the spark signal for cylinder three while output 424 generates the spark signal for cylinder six. The outputs 392 and 408 of AND gates 380 and 396, provide the ignition control signals for ignition coils of cylinders three and six, respectively. Alternatively, the ignition control signals for cylinders three and six could be generated by the microprocessor 74 in multiplexed form and combined along with the combined timing output signal at 344 and demultiplexed by a circuit similar to DMUX 428. The outputs 360 and 376 of AND gates 348 and 364, respectively, provide the multiplexed ignition control signals for ignition coils of cylinders one and four and cylinders two and five, respectively.

The time delay ignition control circuit 200 also includes a demultiplexer (DMUX) 428. The DMUX 428 includes AND gates 432 and 436 and AND gates 440, 444, 448, and 452. DMUX receives as inputs the outputs 360 and 376 of AND gates 348 and 364, respectively, and control outputs 456 and 460 of microprocessor 74 to demultiplex the multiplexed ignition control signals for cylinders one and four and two and five that are generated at outputs 360 and 376, respectively. DMUX generates the demultiplexed ignition control signals at outputs 464, 468, 472, and 476 for cylinders one, four, two, and five, respectively.

In operation, the time delay ignition circuit 200 is used at low speeds, i.e., speeds of 200 to 2000 crankshaft rotations per minute (RPM), and has been shown to operate particularly well at speeds as low as 200 RPM. At speeds

above 2000 RPM the ignition is preferably controlled using a conventional crankshaft angle-based timing system. The microprocessor supplies an injection signal for cylinder one at input 264 of OR gate 240 and for cylinder four at input 268 of OR gate 240. Thus the injection signals for cylinders one and four are
5 combined at the output 252 of the OR gate 240. Likewise, the injection signals for cylinders two and five are combined at the output 256 of OR gate 244 and the injection signals for cylinders three and six are combined at the output 260 of OR gate 248. The injection signals are input to timer trigger inputs 212, 216, and 220, respectively. Based on multiplexed timing data received from the microprocessor
10 via data inputs 208, a combined timing signal is generated for cylinders one and four at output 228, for cylinders two and five at output 232, and for cylinders three and six at output 236. The combined timing signals are combined with combined spark control signals for cylinders one and four, and cylinders two and five, respectively, to create a pair of combined ignition signals for cylinders one
15 and four, and two and five. DMUX 428 demultiplexes the combined ignition signals to generate an absolute time-based ignition signal for cylinders one, four, two, and five.

The microprocessor also generates separate spark control signals for cylinders three and six at microprocessor outputs 420 and 424, respectively. The
20 spark control signals are input to AND gates 380 and 396 to generate absolute time-based ignition signals for cylinders three and six at outputs 392 and 408, respectively.

While the embodiment described above changes between time-based ignition and crank-angle-based ignition on the basis of engine speed only, one or
25 more of a variety of other engine parameters may be used, either alone or in combination, to determine when to switch between time-based ignition and crank-angle-based ignition. Examples of other appropriate engine parameters include engine load, throttle position or some other appropriate parameter.

FIGS. 5-9 illustrate, in chart form, the injection timing, ignition timing,
30 absolute maximum ignition coil on-time, preferred ignition coil on-time and injection pulse time of a control scheme for the ignition circuit 200. As shown in FIGS. 5-9, the engine operates with time-based ignition at a low percentage of wide open throttle (approximately 15% of wide open throttle or below) and with

-10-

crank-angle-based ignition at a high percentage of wide open throttle (above approximately 15% of wide open throttle). That is, the change from time-based ignition to crank-angle-based ignition is based solely on the throttle position measured as a percentage of wide open throttle.

5 The injection timing shown in FIG. 5 is measured in degrees before top-dead-center. When the ignition circuit 200 is operating in the time-based mode, i.e., the throttle position is 150 or less, the injection timing numbers in FIG. 5 represent the number of degrees before top-dead-center that the current begins to flow in the fuel injector coil. When the ignition circuit 200 is operating in the
10 crank-angle-based mode, i.e., the throttle position is greater than 150, the injection timing numbers in FIG. 5 represent the number of degrees before top-dead-center that fuel spray into the combustion chamber begins.

FIG. 10 illustrates graphically the change between time-based ignition and crank-angle-based ignition for another alternative control scheme for the ignition
15 circuit 200. As shown in FIG. 10, the engine operates with time-based ignition at a low percentage of throttle position and at low speed, and operates with crank-angle-based ignition at either a high percentage of throttle position or at high speeds. As shown in FIG. 10, ignition is time based if engine speed is below 1000 RPM and operator throttle demand is less than twenty percent (i.e., the throttle
20 position sensor detects a throttle position less than twenty percent of maximum - shown as "200 T.P.S." in FIG. 10). If engine speed is above 1000 RPM or operator throttle demand is greater than twenty percent, ignition is crank-angle-based. This is controlled by the ECU, as described above. It has been found that this "dual strategy" of transition from time-based ignition to crank-angle-
25 based ignition provides good running quality in an outboard motor by crossing over by engine speed and provides good acceleration characteristics by crossing over by throttle position. The preferred ignition system is disclosed in U.S. Serial No. 60/020,033, filed June 21, 1996, and titled "MULTIPLE SPARK
CAPACITIVE DISCHARGE IGNITION SYSTEM FOR AN INTERNAL
30 COMBUSTION ENGINE", which is incorporated hereby by reference.

Various features and advantages are set forth in the following claims.

The corresponding structures, materials, acts, and equivalents of all means or step plus function elements in the claims below are intended to include any

structure, material, or act for performing the function in combination with other claimed elements as specifically claimed.

Finally, it is to be understood that throughout the description and claims of this specification the word "comprise" and variations of that word such as
5 "comprises" and "comprising" are not intended to exclude other additives, components, integers or steps.

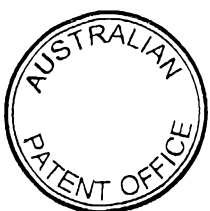
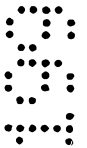
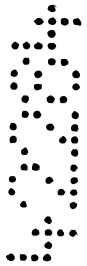

CLAIMS

1. An internal combustion engine assembly comprising:
an internal combustion engine including an engine block having at least one
5 cylinder;
a piston mounted within said cylinder for reciprocal movement in said cylinder;
a fuel injector for injecting fuel into said cylinder;
circuit means for generating an injection control signal indicative of a fuel
injection event;
10 a timer for measuring the time elapsed since generation of said injection
control signal by generating a timing signal corresponding to said elapsed time; and
means responsive solely to said elapsed time for generating a spark within said
cylinder.
- 15 2. An internal combustion engine assembly as set forth in claim 1 wherein
said circuit means includes a microprocessor having an injector output for generating
said injection control signal, and wherein said injector output is connected to said
timer to initiate said timing signal.
- 20 3. An internal combustion engine assembly as set forth in claim 2 wherein
said circuit means further includes means for generating a spark signal, and an AND
gate receiving said timing signal and said spark signal.
- 25 4. An internal combustion engine assembly as set forth in claim 3 wherein
said AND gate generates an ignition current in response to receipt of both said timing
signal and said spark signal.
- 30 5. An internal combustion engine assembly as set forth in claim 4 wherein
said spark is generated when said AND gate stops generating said ignition current.
6. An internal combustion engine assembly as set forth in claim 5 wherein
said AND gate stops generating said ignition current when said timer stops generating
said timing signal.

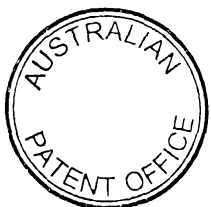

IPEA/US 23 FEB 1998

7. An internal combustion engine assembly comprising:
an internal combustion engine including an engine block having at least one
cylinder;
a piston mounted within said cylinder for reciprocal movement in said cylinder;
5 a fuel injector for injecting fuel into said cylinder; and
a circuit for generating an injection control signal indicative of a fuel injection
event, said circuit including a timer having a timer output for generating an electrical
timing signal, said timing signal having a predetermined duration indicating an amount
of time elapsed from generation of said injection control signal.

10

8. An internal combustion engine assembly as set forth in claim 7 wherein
said timer includes a trigger input and wherein said circuit includes a microprocessor
connected to said trigger input to initiate generation of said timing signal.

15

9. An internal combustion engine assembly as set forth in claim 8 wherein
said circuit includes an AND gate connected to said timer output, said AND gate
generating an output signal for initiating a spark in said cylinder.

20

10. An internal combustion engine assembly as set forth in claim 9 wherein
said circuit includes means having a spark output for generating a spark signal, and
wherein said AND gate is also connected to said spark output.

25

11. An internal combustion engine assembly as set forth in claim 10
wherein said AND gate generates an ignition current in response to receipt of both
said timing signal and said spark signal.

30

12. An internal combustion engine assembly as set forth in claim 11
wherein said spark is generated when said AND gate stops generating said ignition
current.

13. An internal combustion engine assembly as set forth in claim 12
wherein said AND gate stops generating said ignition current when said timer stops
generating said timing signal.



14. A method of timing the ignition of fuel in an internal combustion engine, said engine including an engine block having at least one cylinder, a piston mounted within said cylinder for reciprocal movement in said cylinder, a crankshaft connected to said piston and mounted for rotational movement in response to reciprocal movement of said piston, and a fuel injector for injecting fuel into said cylinder, said method comprising the steps of:

5 initiating an injection event;
generating an injection control signal in response to said injection event;
measuring the time elapsed since generation of said injection control
10 signal by generating a timing signal corresponding to said elapsed time;
generating a spark signal; and
generating an ignition current in said cylinder solely as determined by the occurrence of said timing signal and said spark signal.

15 15. A method as set forth in claim 14 wherein the step of generating said ignition current further includes the step of generating said ignition current solely in response to the simultaneous occurrence of said timing signal and said spark signal.

20 16. A method as set forth in claim 14 and further including the step of generating said ignition current in response to crankshaft position at an engine speed above a predetermined threshold.

25 17. A method as set forth in claim 14 and further including the step of generating said ignition current in response to crankshaft position when an engine condition exceeds a given range.

18. A method as set forth in claim 17 wherein the engine condition is engine speed.

30



19. A method as set forth in claim 17 wherein the engine condition is throttle position.

20. A method as set forth in claim 14 and further including the step of
5 generating said ignition current in response to crankshaft position when one of two engine conditions exceeds a given range.

21. A method as set forth in claim 20 wherein said two engine conditions are engine speed and throttle position.

10

22. A method of operating an internal combustion engine, said method comprising the steps of:

15

operating the engine with time-based ignition when an engine condition is in a given range; and

operating the engine with crank-angle-based ignition when the engine condition is not in the given range.

20

23. A method as set forth in claim 22 wherein the given range is below a predetermined value.

24. A method as set forth in claim 22 wherein the engine condition is one of engine speed, throttle position, and engine load.

25

25. A method of operating an internal combustion engine, said method comprising the steps of:

operating the engine with time-based ignition when all of a plurality of engine conditions are in respective given ranges; and

operating the engine with crank-angle-based ignition when any one of the engine conditions is not in the respective given range.

30



26. A method as set forth in claim 25 wherein each given range is below a respective predetermined value.

27. A method as set forth in claim 26 wherein each engine condition is one of engine speed, throttle position, and engine load.

28. A method of operating an internal combustion engine, said method comprising the steps of:

operating the engine with time-based ignition at low loads and low speed; and

operating the engine with crank-angle-based ignition at either high loads or high speeds.

29. An internal combustion engine assembly substantially as herein described with reference to the accompanying drawings.

30. A method of timing the ignition of fuel in an internal combustion engine substantially as herein described with reference to the accompanying drawings.

31. A method of operating an internal combustion engine substantially as herein described with reference to the accompanying drawings.

DATED: 11 January, 1999

PHILLIPS ORMONDE & FITZPATRICK

Attorneys for:

FICHT GMBH & CO. KG

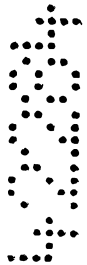

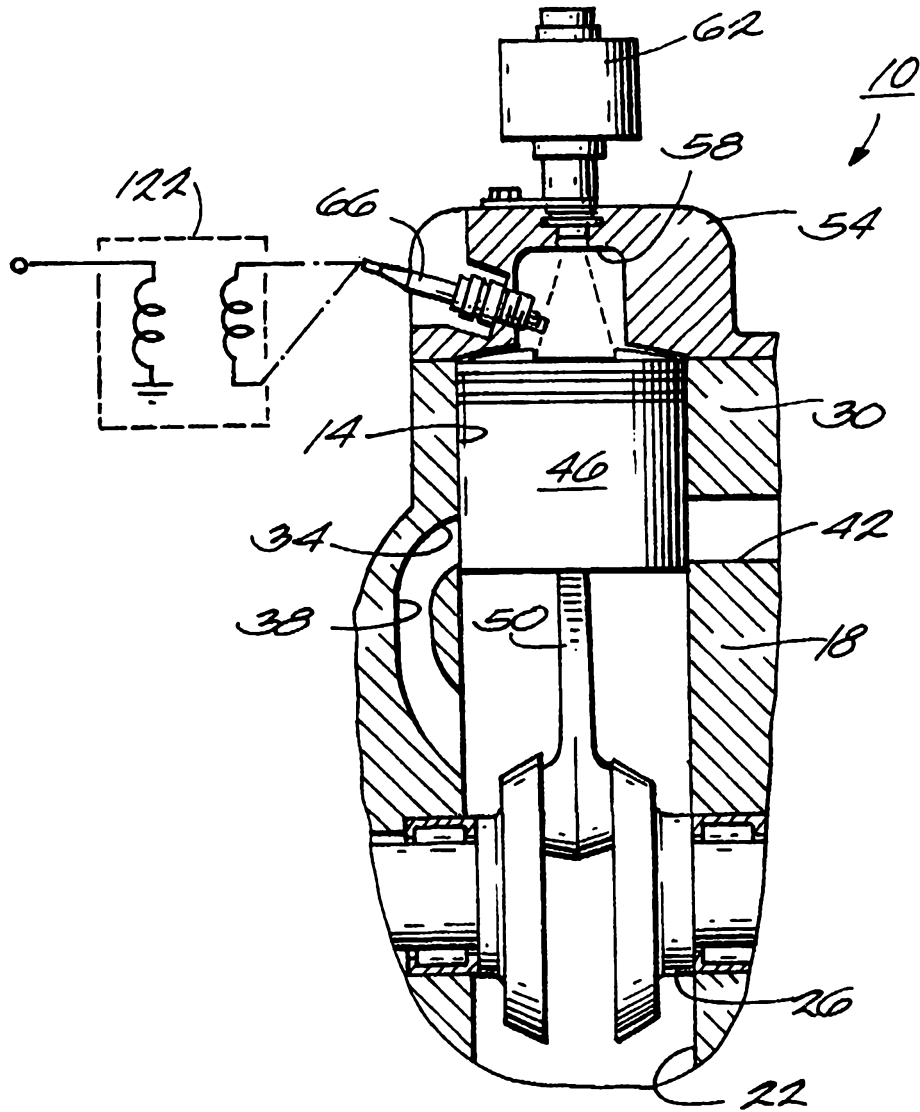
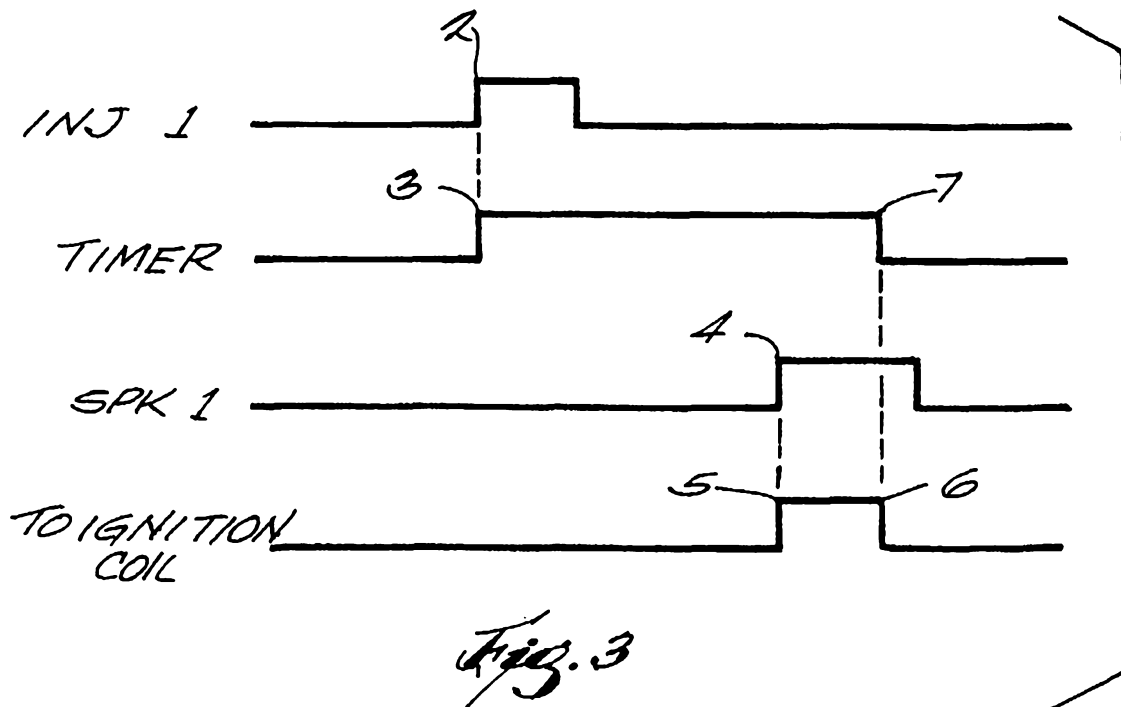
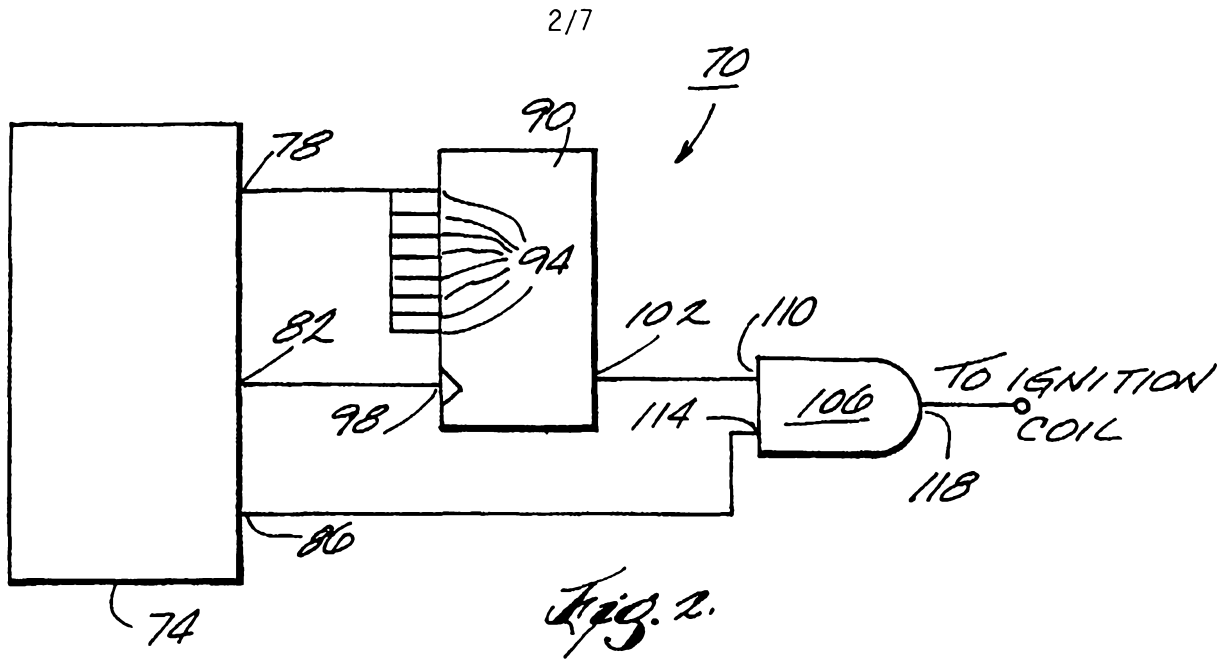

Fig. 1



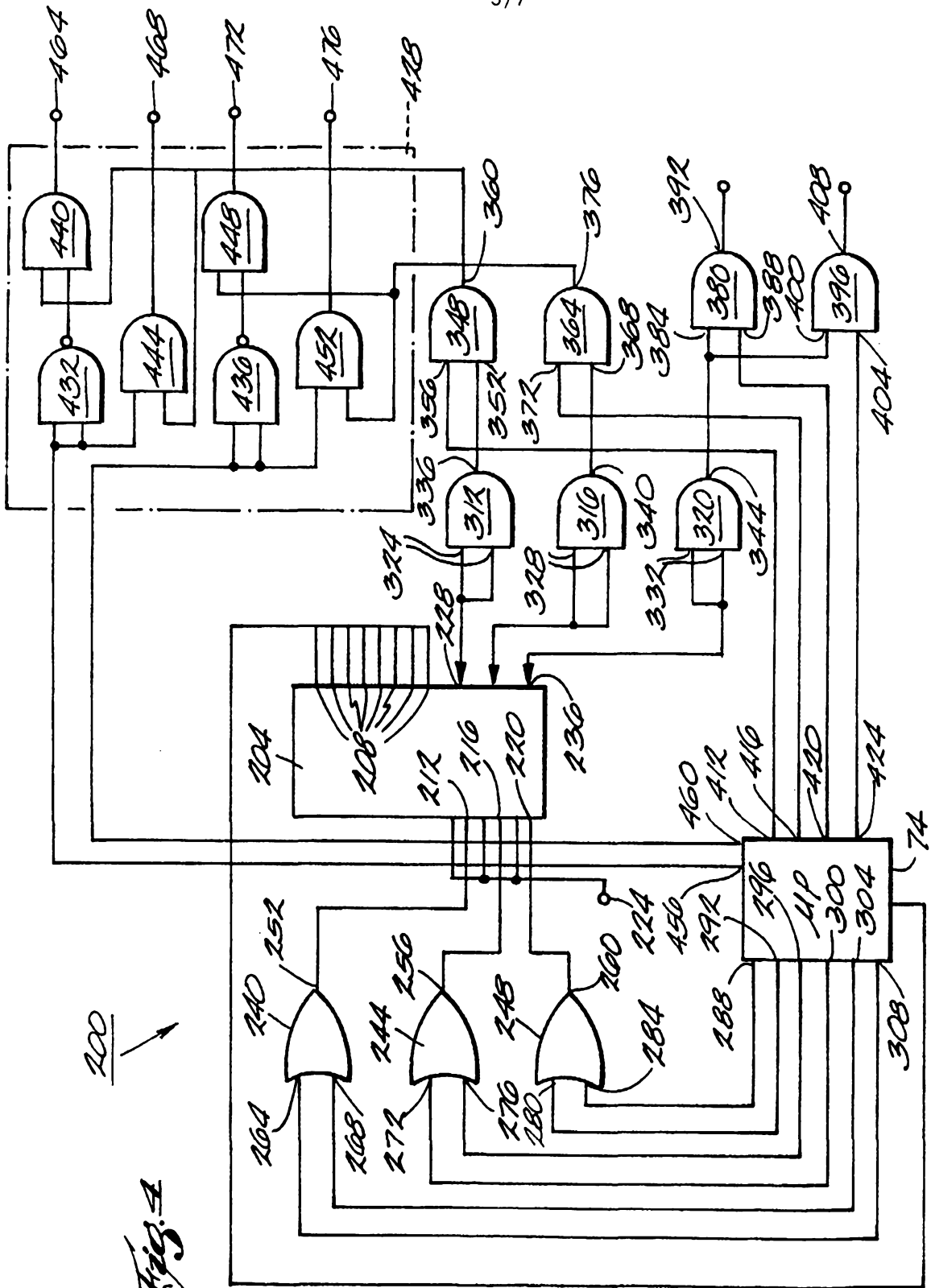

Fig. 5

INJECTION TIMING
(Degrees Before Top-Dead-Center ("DBTDC"))

WO 97/48903

4/7

PCT/US97/10636

	y1/x1	200	400	500	600	700	800	900	1000	1100	1200	1300	1400	1500	2000	2500	3000	3500	4000	4500	5000	5500	7000		
T	0	21	15	10	9	7	6	5	5	5	5	5	5	5	5	5	5	5	5	5	5	5	5	5	Represents moment, in DBTDC, when current begins to flow in injector coil.
H	50	30	30	30	30	30	30	31	35	40	40	40	40	40	40	40	40	40	40	40	40	40	40	40	
R	100	70	70	70	70	70	70	70	70	70	70	75	75	75	95	95	95	95	95	95	95	95	95	95	
O	150	60	60	60	60	60	60	65	70	80	85	85	90	90	95	95	95	95	95	95	95	95	95	95	
T	151	155	155	155	155	155	155	155	155	150	145	140	140	140	150	160	160	160	160	160	160	160	160	160	Represents moment, in DBTDC, when fuel spray from injector into combustion chamber begins.
T	200	210	210	210	210	210	210	210	200	185	205	200	195	195	195	200	205	205	210	205	205	205	205	205	
L	300	205	205	205	215	215	215	210	205	185	190	195	185	185	200	200	195	205	205	210	215	215	215	215	
E	400	205	205	205	215	215	213	210	205	190	205	195	195	185	195	195	205	205	205	205	220	220	215	215	
	500	210	210	210	215	215	213	210	210	195	195	200	200	200	200	205	205	205	205	210	220	220	215	215	
P	600	210	210	210	215	215	213	210	210	195	205	190	195	190	205	205	205	205	210	220	220	215	215	215	
O	700	210	210	210	215	215	215	210	210	210	205	210	210	205	210	210	205	215	215	220	220	215	215	215	
S.	800	210	210	210	215	215	220	210	210	205	205	210	210	205	210	210	205	215	215	220	220	215	215	215	
	1000	210	210	210	215	215	215	210	210	205	205	210	210	205	210	210	205	215	215	220	220	215	215	215	

Fig. 6

IGNITION TIMING

	y1/x1	200	400	500	600	700	800	900	1000	1100	1200	1300	1400	1500	2000	2500	3000	3500	4000	4500	5000	5500	7000	UNITS
T	0	1.0	1.0	1.0	1.0	1.0	1.0	1.0	1.0	1.0	1.0	1.0	1.0	1.0	1.0	1.0	1.0	1.0	1.0	1.0	1.0	1.0	1.0	(ms)
H	50	1.5	1.5	1.5	1.5	1.5	1.5	1.0	1.0	1.0	1.0	1.0	1.0	1.0	1.0	1.0	1.0	1.0	1.0	1.0	1.0	1.0	1.0	(ms)
R	100	3.0	3.0	3.0	1.0	3.0	2.5	2.0	1.5	1.5	1.5	1.5	1.5	1.5	1.5	1.5	1.5	1.5	1.5	1.5	1.5	1.5	1.5	(ms)
O	150	4.0	4.0	4.0	4.0	4.0	3.5	3.0	2.0	1.5	1.5	1.5	2.5	1.5	1.5	1.5	1.5	1.5	1.5	1.5	1.5	1.5	1.5	(ms)
T	151	0.0	0.0	0.0	0.0	0.0	0.0	0.0	0.0	0.0	0.0	0.0	0.0	0.0	-1.0	-2.0	-2.0	-2.0	-2.0	-2.0	-2.0	-2.0	-2.0	Deg. BTDC
T	200	4.0	4.0	4.0	4.0	6.0	8.0	10.0	18.0	15.0	14.0	20.0	18.0	20.0	20.0	20.0	20.0	20.0	20.0	18.0	18.0	18.0	18.0	Deg. BTDC
L	300	4.0	4.0	4.0	4.0	6.0	8.0	10.0	16.0	16.0	16.0	17.0	20.1	18.3	20.0	20.0	18.0	20.0	20.0	18.0	30.0	24.0	24.0	Deg. BTDC
E	400	4.0	4.0	4.0	4.0	6.0	8.0	10.0	16.0	16.0	14.0	17.0	17.0	18.0	18.0	18.0	18.0	18.0	18.0	22.0	26.0	28.0	28.0	Deg. BTDC
	500	4.0	4.0	4.0	4.0	6.0	8.0	9.0	14.0	16.0	16.0	17.0	17.0	17.0	18.0	18.0	18.0	18.0	20.0	18.0	26.0	28.0	28.0	Deg. BTDC
P	600	4.0	4.0	4.0	4.0	6.0	7.0	1.0	14.0	16.0	14.0	15.0	17.1	18.0	10.0	18.1	18.1	18.0	18.0	22.0	24.0	10.0	30.0	Deg. BTDC
O	700	4.0	4.0	4.0	4.0	6.0	6.5	7.0	12.0	14.0	14.0	14.0	16.0	16.0	16.0	16.0	18.0	18.0	18.0	20.0	26.0	28.0	28.0	Deg. BTDC
S	800	4.0	4.0	4.0	4.0	6.0	6.5	7.0	12.0	14.0	14.0	14.0	16.0	16.0	16.0	16.0	18.0	18.0	18.0	20.0	26.0	28.0	28.0	Deg. BTDC
	1000	4.0	4.0	4.0	4.0	6.0	6.0	7.0	12.0	14.0	14.0	14.0	16.0	16.0	16.0	16.0	18.0	18.0	18.0	20.0	26.0	28.0	28.0	Deg. BTDC

5/7

Fig. 7

RPM	IGNITION ON TIME
1000	5.0msec.
1500	5.0msec.
2000	3.5msec.
2500	2.5msec.
3000	2.0msec.
3500	1.5msec.
4000	1.0msec.
4500	1.0msec.
5000	.8msec.
5500	.7msec.
6000	.6msec.

Fig. 8

IGNITION-COIL-ON-TIME (ms)

	y1/x1	200	400	600	800	700	800	900	1000	1100	1200	1300	1400	1500	2000	2500	3000	3500	4000	4500	6000	5500	7000	
T	0	5.0	5.0	4.0	3.0	3.0	3.0	3.0	3.0	3.0	3.0	3.0	3.0	3.0	3.0	2.5	2.0	1.5	1.0	1.0	0.8	0.7	0.5	
H	50	5.0	5.0	5.0	5.0	3.0	3.0	3.0	3.0	5.0	5.0	3.0	3.0	3.0	3.0	2.5	2.0	1.5	1.0	1.0	0.8	0.7	0.5	
R	100	5.0	5.0	5.0	5.0	3.0	3.0	3.0	3.0	5.0	5.0	5.0	5.0	3.0	3.0	2.5	2.0	1.5	1.0	1.0	0.8	0.7	0.5	
O	150	5.0	5.0	5.0	5.0	3.0	3.0	3.0	3.0	3.0	4.0	5.0	5.0	5.0	3.0	2.5	2.0	1.5	1.0	1.0	0.8	0.7	0.5	
T	151	3.0	3.0	3.0	2.8	0.8	0.8	0.8	0.8	0.8	0.6	0.6	0.6	0.6	0.6	0.6	0.6	0.6	0.6	0.6	0.6	0.6	0.6	0.5
T	200	0.5	0.5	0.5	0.5	0.5	0.5	0.5	0.1	0.5	0.5	0.5	0.5	0.5	0.5	0.5	0.5	0.6	0.8	0.8	0.6	0.6	0.5	
L	300	0.5	0.5	0.5	0.5	0.5	0.5	0.5	0.5	0.5	0.5	0.5	0.5	0.5	0.5	0.5	0.5	0.6	0.8	0.8	0.6	0.6	0.5	
E	400	0.5	0.5	0.5	0.5	0.5	0.5	0.5	0.5	0.5	0.5	0.5	0.5	0.5	0.5	0.5	0.5	0.6	0.8	0.8	0.6	0.6	0.5	
	500	0.5	0.5	0.5	0.5	0.5	0.5	0.5	0.5	0.5	0.5	0.5	0.5	0.5	0.5	0.5	0.5	0.6	0.8	0.8	0.6	0.6	0.5	
P	600	0.5	0.5	0.5	0.5	0.5	0.5	0.5	0.5	0.5	0.5	0.5	0.5	0.5	0.5	0.5	0.5	0.6	0.8	0.8	0.6	0.6	0.5	
O	700	0.5	0.5	0.5	0.5	0.5	0.5	0.5	0.5	0.5	0.5	0.5	0.5	0.5	0.5	0.5	0.5	0.6	0.8	0.8	0.6	0.6	0.5	
S.	800	0.5	0.5	0.5	0.5	0.5	0.5	0.5	0.5	0.5	0.5	0.5	0.5	0.5	0.5	0.5	0.5	0.6	0.8	0.8	0.6	0.6	0.5	
	1000	0.5	0.5	0.5	0.5	0.5	0.5	0.5	0.5	0.5	0.5	0.5	0.5	0.5	0.5	0.5	0.5	0.6	0.8	0.8	0.6	0.6	0.5	

Fig. 9

INJECTION PULSE TIME (ms)

	y1/x1	200	400	600	600	700	800	900	1000	1100	1200	1300	1400	1500	2000	2500	3000	3600	4000	4500	6000	5500	7000
T	0	6.000	6.098	4.619	4.579	4.400	4.299	4.299	4.299	4.300	4.300	4.300	4.300	4.299	4.299	4.299	4.299	4.299	4.299	4.299	4.299	4.299	4.299
H	50	4.818	4.818	4.818	4.719	4.418	4.449	4.450	4.479	4.499	4.519	4.519	4.519	4.519	4.519	4.519	4.519	4.519	4.519	4.519	4.519	4.519	4.519
R	100	4.848	4.848	4.848	4.848	4.748	4.400	4.320	4.270	4.250	4.250	4.220	4.220	4.250	4.230	4.230	4.230	4.230	4.230	4.230	4.230	4.230	4.230
O	150	4.830	4.830	4.830	4.830	4.830	4.769	4.739	4.649	4.599	4.499	4.339	4.400	4.319	4.480	4.480	4.480	4.480	4.480	4.480	4.480	4.480	4.480
T	151	4.860	4.860	4.860	5.099	5.080	5.009	5.049	5.080	5.100	5.080	4.880	4.840	4.840	4.789	4.789	4.650	4.530	4.420	4.340	4.250	4.140	4.700
T	200	5.200	5.200	5.200	5.250	5.180	5.149	5.199	5.149	5.089	4.999	4.949	4.899	4.899	4.899	4.899	4.749	4.649	4.449	4.399	4.350	4.200	4.799
L	300	5.199	5.199	5.199	5.349	5.249	5.199	5.299	5.249	5.249	5.199	5.190	5.099	5.099	5.149	5.199	5.199	4.949	4.749	4.649	4.549	4.349	4.599
E	400	5.299	5.299	5.299	5.499	5.399	5.329	5.449	5.399	5.399	5.399	5.299	5.299	5.399	5.549	5.649	5.649	5.399	5.299	5.049	4.849	4.700	4.749
	500	5.500	5.500	5.999	5.549	5.449	5.379	5.549	5.499	5.499	5.550	5.449	5.499	5.599	5.799	6.049	6.199	5.899	5.799	5.549	5.349	5.150	5.049
P	600	5.500	5.500	6.050	5.600	5.500	5.429	5.600	5.550	5.550	5.550	5.550	5.550	5.700	5.850	6.100	6.349	6.099	6.000	5.749	5.450	5.150	5.149
O	700	5.500	5.500	6.050	5.600	5.500	5.429	5.600	5.550	5.550	5.550	5.550	5.550	5.700	5.850	6.100	6.349	6.099	6.000	5.749	5.450	5.150	5.149
S.	800	5.500	5.500	6.050	5.650	5.500	5.429	5.600	5.550	5.550	5.550	5.550	5.550	5.700	5.850	6.100	6.349	6.099	6.000	5.749	5.450	5.150	5.149
	1000	5.500	5.500	6.050	5.650	5.500	5.430	5.600	5.550	5.550	5.549	5.550	5.549	5.700	5.800	6.100	6.350	6.099	6.000	5.750	5.450	5.150	5.149

111

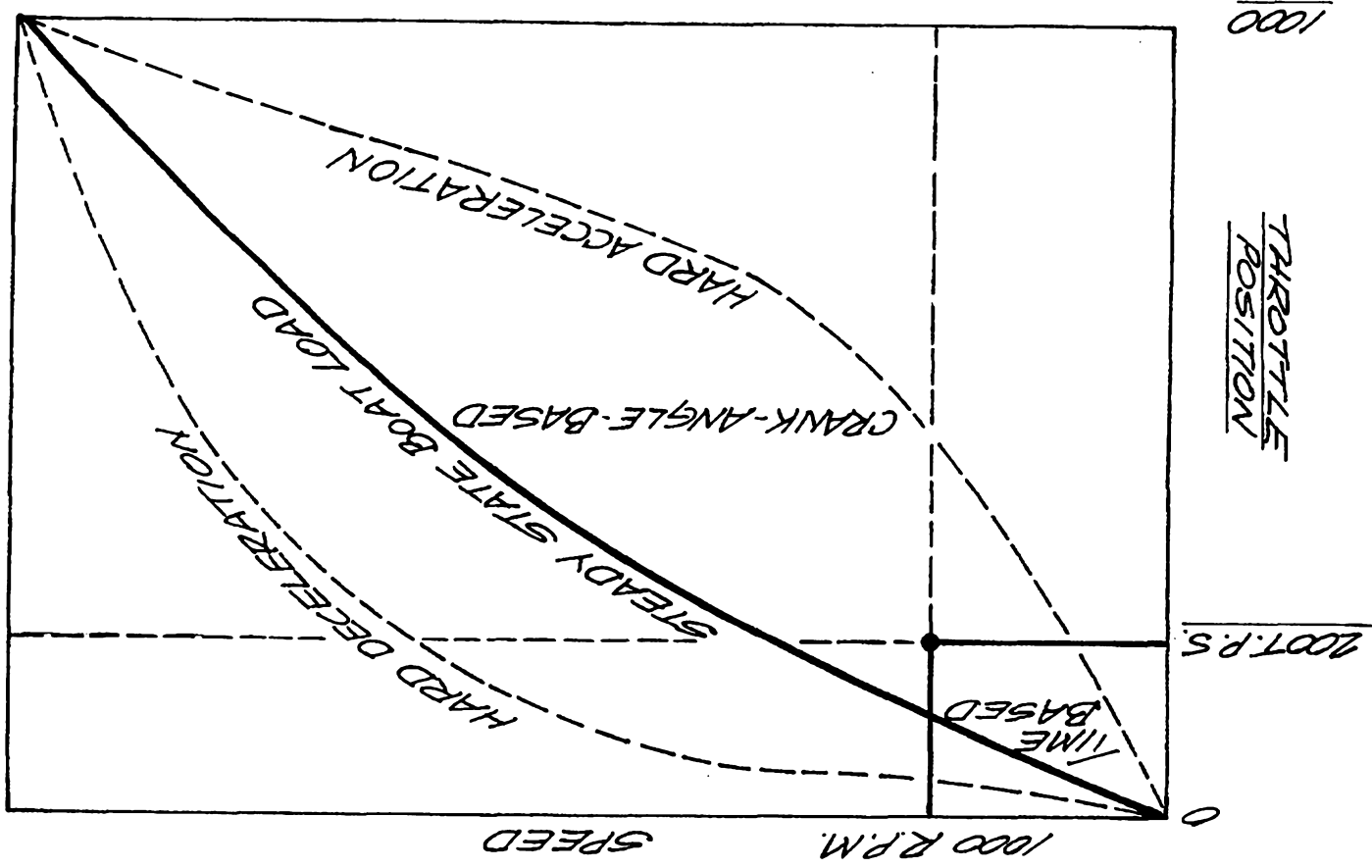

Fig. 10