

March 24, 1970

J. S. AJIOKA

3,503,073

TWO-MODE WAVEGUIDE SLOT ARRAY

Filed Feb. 9, 1968

2 Sheets-Sheet 1

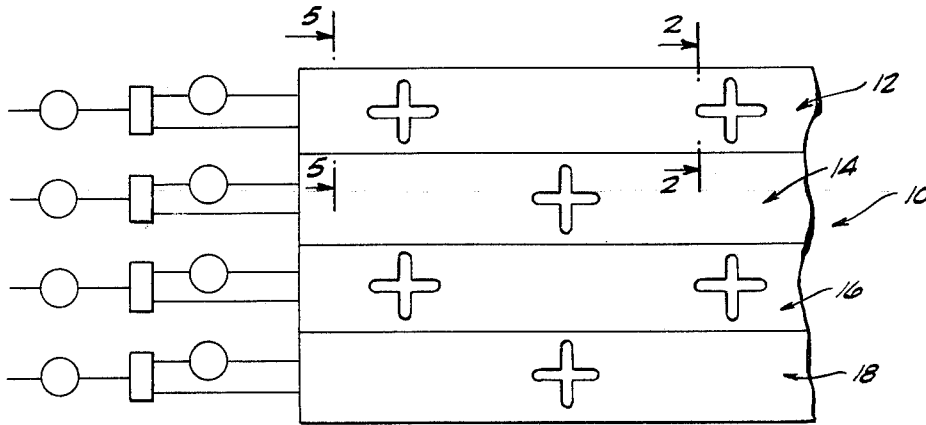

FIG. 1.

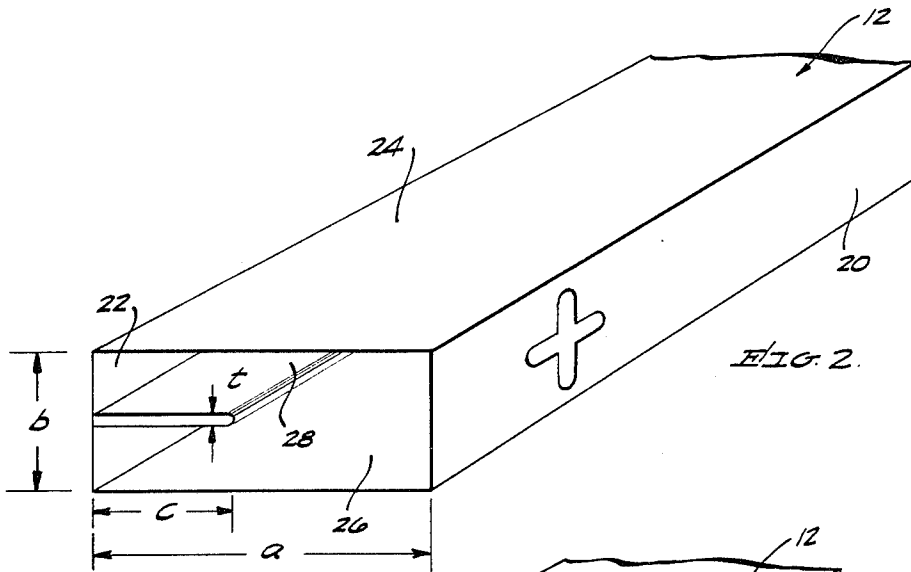

FIG. 2.

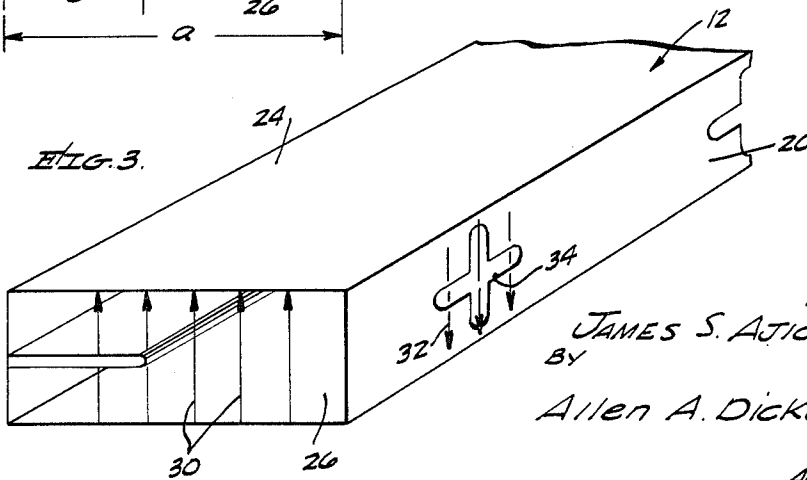

FIG. 3.

INVENTOR
JAMES S. AJIOKA,
BY
Allen A. Dicke, Jr.,
AGENT.

March 24, 1970

J. S. AJIOKA

3,503,073

TWO-MODE WAVEGUIDE SLOT ARRAY

Filed Feb. 9, 1968

2 Sheets-Sheet 2

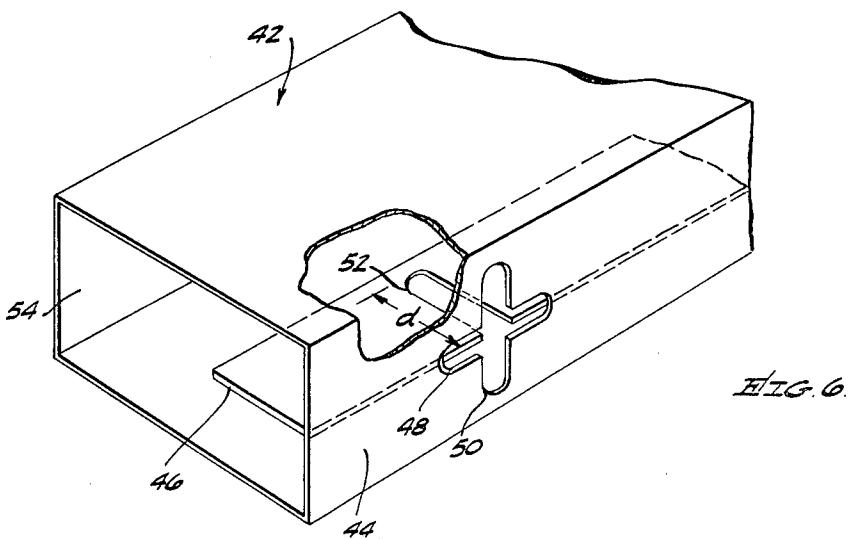
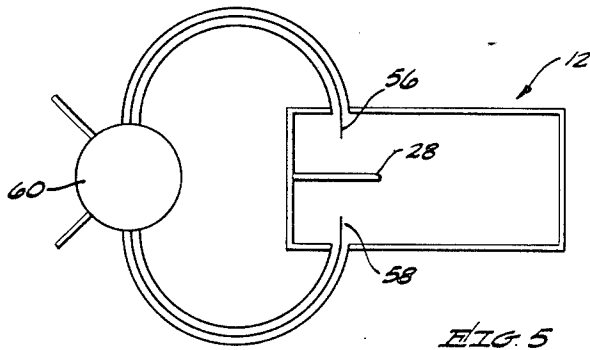
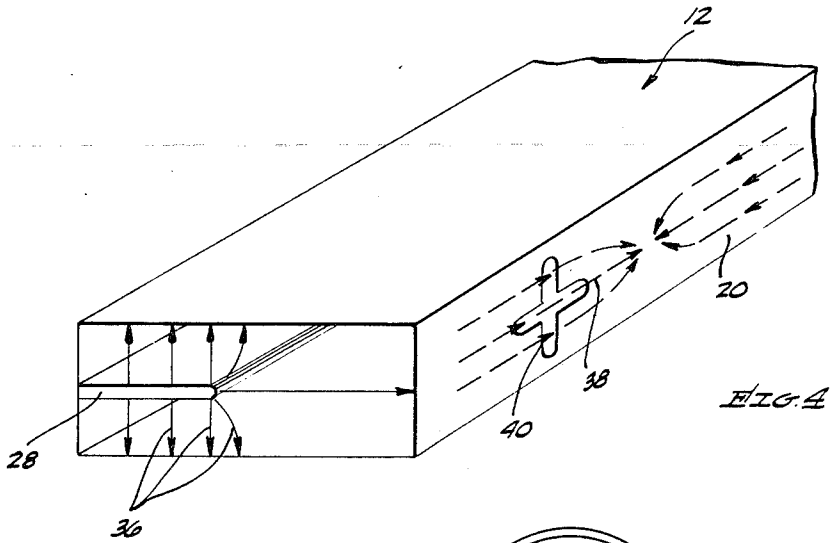

1

2

3,503,073

TWO-MODE WAVEGUIDE SLOT ARRAY

James S. Ajioka, Fullerton, Calif., assignor to Hughes Aircraft Company, Culver City, Calif., a corporation of Delaware

Filed Feb. 9, 1968, Ser. No. 704,439

Int. Cl. H01q 13/10, 3/26

U.S. Cl. 343-771

11 Claims

ABSTRACT OF THE DISCLOSURE

A waveguide slot array antenna has a rectangular outline configuration with one of the rectangular sides having radiating slots therein. Both longitudinal and transverse slots are provided. An interior septum is mounted on one of the walls, either the slotted wall or the opposite wall, and extends out into the interior of the waveguide structure. Opposite sides of this septum are excited in the odd mode and the even mode to cause excitation of the transverse slots by the odd mode and the longitudinal slots by the even mode. Thus polarization of the antenna is controlled by controlling the phase and/or amplitude relationship between the two excitations. In view of the arbitrary height of the slotted wall, stacked arrays with a capability of being scanned by phase shift in that plane are possible, without the formation of grating lobes.

BACKGROUND OF THE INVENTION

This invention is directed to two-mode waveguide slot array antennas, particularly arrays having the capability of being scanned by phase shift.

In accordance with the prior art, a vertically polarized waveguide slot array interleaved with a horizontally polarized array has not been possible. Such a structure would require two sets of feed lines and two sets of radiating elements which must be very closely packed, for the two arrays must occupy the same space as one single array. Such packing is necessary to allow scanning without the formation of grating lobes. Because of such close spacing requirements, conventional slotted waveguides cannot be used. Their use is not possible because such reduced height waveguides are not tall enough to employ resonant slot radiators. Each of such waveguides must be only on the order of a quarter wavelength in height to satisfy the packing criterion, and thus a resonant slot of about a half wavelength cannot fit within the waveguide structure. For these reasons, interleaved rays generally employ coaxial transmission lines and dipole radiating elements. The use of such components results in increased radio frequency power losses, and are capable of only limited power handling capability. Furthermore, such structures are more costly to fabricate.

SUMMARY

In order to aid in the understanding of this invention, it can be stated in essentially summary form that it is directed to a two-mode waveguide slot array. The waveguide has means therein which permits the waveguide to operate in two different modes of identical velocity, and the waveguide need not be square. The waveguide is slotted so that it radiates independently in accordance with each of the two modes of operation.

It is thus an object of this invention to provide a two-mode waveguide slot array which can be operated in two different modes to radiate independently. It is a further object of this invention to provide an array element which is stackable so that a planar faced array is independently polarizable in the horizontal and vertical directions so

that by proper combination of polarizations, any arbitrary polarization is realizable. It is a further object of this invention to provide an array element which is sufficiently thin that it can operate without the formation of grating lobes, and still permit scanning. It is a further object of this invention to provide an array element comprising a waveguide in which a septum is positioned, which septum permits the waveguide to operate in two different modes with the same phase velocity, and to provide slots in the face of the array elements so that the array element can radiate in the proper combination of two orthogonal polarizations to permit scanning without the formation of grating lobes. Other objects and advantages of this invention will become apparent from a study of the following portion of the specification, the claims and the attached drawings.

DESCRIPTION OF THE DRAWINGS

FIGURE 1 is a schematic front elevational view of a two-mode waveguide slot array, with parts broken away,

FIGURE 2 is an isometric view of one of the array elements, showing the relationship of the parts, viewed from section line 2-2.

FIGURE 3 is an isometric view similar to FIGURE 2, showing the array operating with electric field distribution in even mode operation.

FIGURE 4 is a view similar to FIGURE 3 showing the electric field distribution in odd mode operation.

FIGURE 5 is a section taken generally along the line 5-5 showing one embodiment of structure for the feeding of the slotted waveguide.

FIGURE 6 is an isometric view of a further embodiment of a slotted waveguide in accordance with this invention.

DESCRIPTION OF THE PREFERRED EMBODIMENTS

Referring to FIGURE 1, the two-mode waveguide slotted array is generally indicated at 10. The array 10 comprises a plurality of slotted waveguide radiators. They are indicated at 12, 14, 16 and 18. Each of the waveguides is identical, except for the placement of the slots therein. Therefore, for convenience, waveguide 12 will be described in detail. Referring to FIGURE 2, waveguide 12 has a front wall 20 and a rear wall 22, which will define the height b of the array element. Furthermore, the waveguide 12 is formed of a top wall 24 and a bottom wall 26 which define the depth a of the waveguide. Formed at the mid-point of rear wall 22, and extending forward toward front wall 20, and extending the length of waveguide 12 is septum 28. Septum 28 has a thickness t and extends a distance c from the rear wall.

A requirement of the dual mode waveguide is that one dimension must be on the order of half wavelength or less so that a large angle of scan normal to the wavelength axis can be achieved without the formation of higher order beams or grating lobes when a stack of these waveguide elements is used to form the two-dimensional array 10. Referring to FIGURE 3, waveguide 12 has a uniform electric field distribution between top wall 24 and bottom wall 26, as indicated by arrows 30 when the waveguide is excited in the even mode. The even mode is essentially the same as the dominant transverse electric field mode in a rectangular waveguide. This is exactly true for an infinitely thin septum 28, which has a zero thickness t . This mode excites a current in the front wall 20 in the direction parallel to the field, transverse to the waveguide axis, so that the current flows in accordance with arrow 32. This excites longitudinal slots in the front wall 20, such as slot 34.

Referring to FIGURE 4, excitation of waveguide 12

in the odd mode produces field lines which are in anti-phase on each side of the septum. This field is illustrated by arrows 36. Such excitation causes longitudinal current flow in the front wall 20, as is illustrated by arrows 38. This current in turn excites slots in the front wall 20 which are arranged perpendicular to the current flow, such as slot 40.

The depth and height a and b are dictated by the antenna array performance criteria, with the depth a determined so that the dominant mode is not cut off. The height b is chosen so the array can be scanned without the formation of grating lobes. By choosing the proper septum length c and proper thickness t , for given depth and height a and b dimensions, the odd and even modes can be made to have exactly the same cutoff wavelength. These dimensions can be determined mathematically or experimentally. If the cutoff wavelength is the same, then the phase velocity and guide wavelength remain the same for all frequencies. Thus, the guide wavelength is the same for the even and odd modes.

It having been established that two independent, mathematically orthogonal modes can be propagated at the same velocity in the septated waveguide, it is required that each of these modes be coupled independently to the two orthogonal slots 34 and 40, in the manner described above. That is, the even mode must excite the longitudinal slot 34, while the odd mode must excite the transverse slot 40 in the same waveguide wall. For the even mode, the current distribution in the wall, as illustrated by arrows 32, is transverse, as it is in a rectangular waveguide operating in the dominant transverse electric mode. Hence the longitudinal slot 34 is excited by this current as in a conventional shunt slot in the narrow wall of a rectangular waveguide. This slot is not excited by the longitudinal current due to the odd mode, because of its narrow width. Similarly, the transverse slot 40 is excited only by the longitudinal current illustrated by arrow 38 due to the odd mode excitation. The slots 34 and 40 have been discussed separately, but it is clear that they can be superimposed as is shown in the figures and still act independently and be independently excited by the even and odd modes. If either slot is rotated from its principal axis, it will couple to both modes.

It is also required that the slots be arrayed into a two-dimensional array of slotted waveguides in which the beam radiated from the slots can be scanned over a wide angle transverse to the waveguide axis without the formation of higher order beams or grating lobes. In the present array 10, the waveguides are horizontally positioned and are mounted one on top of the other to form a vertical front face. In this case, the beam scan is in a vertical plane perpendicular to the front face.

The criterion for scan without the formation of grating lobes is that the dimension between arrays in the direction of the plane of scan divided by the free space wavelength must be equal to one divided by one plus the sine of the angle of scan away from normal to the antenna face. The height of the waveguide is the critical dimension and must be very close to a half wavelength to satisfy the grating lobe criterion for large angles of scan. The septated waveguide arrangement allows this height dimension of an individual waveguide to be smaller than half a wavelength and still allow for the propagation of both modes with the same phase velocity.

In the direction of the waveguide axes, the slot spacing in any waveguide must be equal to the wavelength in the guide to have them all in phase. This would normally result in grating lobes even when there is no scan in this plane, since the guide wavelength is generally longer than the free space wavelength for a non-dielectrically loaded waveguide. To overcome this problem, the slots in adjacent waveguides are staggered, as is shown in FIGURE 1. In this way, the horizontal distance between slots in adjacent waveguides is substan-

tially equal to half the guide wavelength, which satisfies the grating lobe criteria in the non-scanning plane in accordance with the above equation, while the distance between the slots in the same guide is equal to the guide wavelength.

FIGURES 1 through 4 show the slots positioned in the wall opposite the septum. However, as is illustrated in FIGURE 6, waveguide 42 has a front wall 44 on which septum 46 is mounted. Longitudinal slot 48 and transverse slot 50 are formed in wall 44. As in the previous embodiment, the even mode slot 48 is excited in the same manner as a conventional shunt slot on the narrow wall of the waveguide. The effect of septum 46 on this mode is very small. Thus, the excitation of longitudinal slot 48 is substantially identical to that described with respect to longitudinal slot 34.

However, the excitation of transverse slot 50 differs from that described with respect to slot 40. In this case, septum slot 52 is formed in septum 46 and is aligned with slot 50. The slot in the septum is excited by longitudinal currents in the septum 46 due to the odd mode excitation. This takes place because the currents on both sides of the septum flow in the same direction for the odd mode, and these are interrupted by the slot, creating a voltage across the slot. The currents due to the even mode, flow in opposite directions on opposite sides of the septum, and thus their effects cancel out the slot so that the slot is not excited. In other words, the slot 52 and the septum are excited only by the odd mode and this slot excitation excites the transverse slot 50 in the waveguide wall without exciting longitudinal slot 48. The depth d of septum slot 52 controls the amount of excitation thereof, and thus the amount of excitation of slot 50.

In cases where the septum 46 extends all the way across the waveguide to join with the rear wall 54, this results in two separate waveguides. When the waveguides are fed in phase, they operate in the even mode, and when they are fed in anti-phase, they operate in the odd mode.

There are several ways in which the even and odd modes can be excited in the septated waveguide. The preferred method is to use a waveguide E-plane folded magic T whose output ports are coincident with each half of the septated waveguide. At the junction of the magic T and the septated waveguide, the common wall of the E-plane folded magic T forms a septum that spans the entire width of the waveguide. This septum is preferably stepped to form a transition to the waveguide septum. When the sum port of the magic T is fed, the even mode is generated in the septated waveguide. When the difference port of the magic T is fed, the odd mode is generated.

Another way to excite the septated waveguide is illustrated in FIGURE 5 wherein probes 56 and 58 which are positioned on opposite sides of septum 28 are fed from a hybrid, such as hybrid 60. Summing and differencing can be done by and convenient hybrid such as a magic T or a ring hybrid, and either are useful as the hybrid 60. Thus, when the probes are fed in phase, the even mode is excited and when the probes are fed in anti-phase the odd mode is excited.

This invention having been described in its preferred embodiment, and an alternative embodiment shown, it is clear that it is susceptible to numerous modifications and embodiments within the ability of those skilled in the art and without the exercise of the inventive faculty. Accordingly, the scope of this invention is defined by the scope of the following claims:

What is claimed is:

1. A waveguide antenna, said waveguide antenna comprising:

a waveguide having walls, a slot in one of said waveguide walls for radiating energy from said waveguide in accordance with current induced in said slotted wall;

5

a septum in said waveguide, said septum being arranged so that when the waveguide spaces on opposite sides of said septum are excited in the same phase, said slotted wall carries currents transversely to the length of said waveguide and when said spaces on the opposite sides of said septum are excited in anti-phase, currents are induced in said slotted wall along the length of said waveguide.

2. The waveguide antenna of claim 1 wherein there are both longitudinal and transverse slots in said slotted wall.

3. The waveguide of claim 2 wherein said longitudinal and transverse slots in said slotted wall intersect.

4. The waveguide of claim 1 wherein said septum is arranged so that the wavelength of waves within said waveguide are substantially equal when the spaces on the opposite sides of said septum are excited in phase and in anti-phase.

5. The waveguide of claim 4 wherein the height of said slotted wall is the height of said waveguide and the distance from said slotted wall to its opposite wall are the depth of said waveguide, said height of said waveguide being lesser than the depth of said waveguide.

6. The waveguide of claim 5 wherein the height of said waveguide is substantially half wavelength of the free space wavelength of the excitation frequency.

6

7. The waveguide of claim 6 wherein a plurality of waveguides are arranged with their slotted walls lying in a common plane, the slots in adjacent waveguides being axially spaced from each other.

8. The waveguide of claim 7 wherein there are a plurality of slots in each of said waveguides in said array.

9. The waveguide of claim 1 wherein said septum is secured to a wall of said waveguide opposite said slotted wall.

10. The waveguide of claim 1 wherein said septum is secured to said slotted wall.

11. The waveguide of claim 10 wherein said septum has a septum slot therein aligned with said slot in said slotted wall so excitation of said septum slot excites said slot in said slotted wall.

References Cited

UNITED STATES PATENTS

2,982,960 5/1961 Shanks 343—771 X

ELI LIEBERMAN, Primary Examiner

MARVIN NUSSBAUM, Assistant Examiner