

[54] **DEVICE FOR THE ORAL ADMINISTRATION OF MEDICINE**

[76] Inventor: **Nicholas P. Armenti**, 50 Thorn Terrace, West Orange, N.J. 07052

[22] Filed: **June 6, 1972**

[21] Appl. No.: **260,265**

- [52] U.S. Cl. 128/222, 128/272, 128/218 C
- [51] Int. Cl. A61j 7/00, A61m 5/22
- [58] Field of Search..... 128/222, 223, 215, 218 R, 128/218 C, 218 P, 218 F, 234, 218 PA, 272, 2 F, DIG. 24, DIG. 5, 218 M, 275, DIG. 28, 218 P, 218 N; 222/96, 106, 192, 145, 386; 141/5

References Cited

UNITED STATES PATENTS

| | | | |
|-----------|---------|-----------------|-------------|
| 811,811 | 2/1906 | Allison | 128/214 R |
| 1,617,066 | 2/1927 | Lush | 215/DIG. 3 |
| 2,268,592 | 1/1942 | Hothersall..... | 222/386 X |
| 2,409,656 | 10/1946 | Austin..... | 128/218 C |
| 2,502,639 | 4/1950 | Blake | 128/218 C |
| 2,627,857 | 2/1953 | Marcelli | 128/218 F |
| 2,666,434 | 1/1954 | Ogle | 128/218 P |
| 2,844,148 | 4/1958 | Raife..... | 128/218 C |
| 2,847,009 | 8/1958 | Blease..... | 128/222 |
| 3,337,041 | 8/1967 | Damaskus..... | 128/272 |
| 3,422,995 | 1/1969 | Carpigiani..... | 222/309 |
| 3,493,503 | 2/1970 | Mass | 128/234 X R |
| 3,735,900 | 5/1973 | Gores..... | 222/386 X |

FOREIGN PATENTS OR APPLICATIONS

| | | | |
|-----------|--------|---------------|-----------|
| 1,006,589 | 4/1957 | Germany | 128/234 |
| 493,373 | 6/1953 | Canada..... | 128/218 N |

Primary Examiner—Richard A. Gaudet
Assistant Examiner—J. C. McGowan
Attorney, Agent, or Firm—Mel K. Silverman, Esq.

[57] **ABSTRACT**

The present invention constitutes a device for the oral administration of medication, including (1) an elongated hollow cylinder having an opening at one end and a plurality of apertures at an opposite end, the opposite end intended for placement into a pool of liquid medication, the cylinder also having a side wall opening; (2) a reciprocating plunger received within the cylinder, the plunger including a forward portion for assuring an air-and liquid-tight fit between the circumferential periphery of the forward portion and the interior walls of the cylinder, and a shank portion having a radially projecting measuring shelf; (3) a slidable member supported by a radial plane element near the open end of the cylinder, wherein the slidable member will, after a sufficient withdrawal of the plunger toward the open end of the cylinder, pass through the side wall opening and engage the measuring shelf, thereby securing a withdrawal into the cylinder of a predetermined volume of medication, the volume being a function of the longitudinal location of the measuring shelf on the shank portion of the plunger; (4) a bottle for holding medicine, the bottle having a mouth and a cover connected to the mouth, the cover having an opening therein, the opening receiving the cylinder and attaining a press-fitable insertion of the cylinder into the opening, in which the press-fit is both liquid-and air-tight, and in which the opening itself is a partially circumferential female slot for receiving the radial plane element of the cylinder.

9 Claims, 9 Drawing Figures

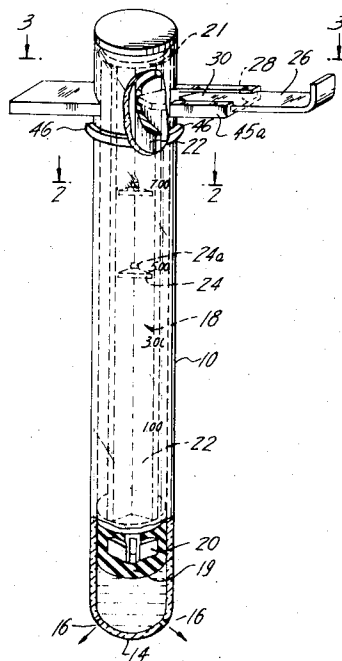

FIG. 1

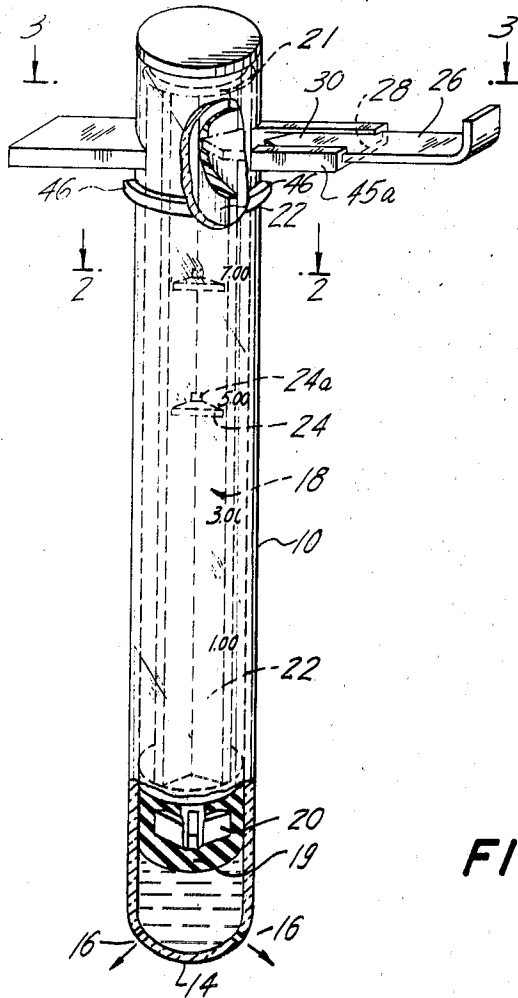

FIG. 2

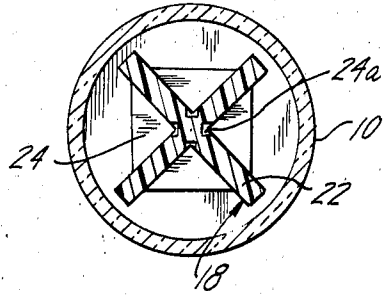

FIG. 5

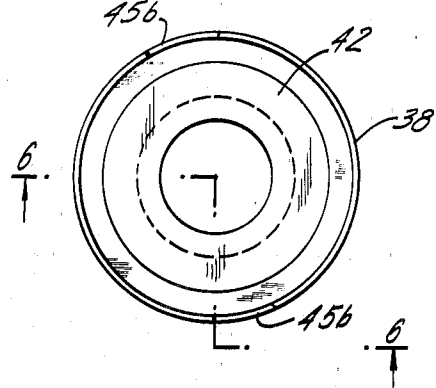

FIG. 6

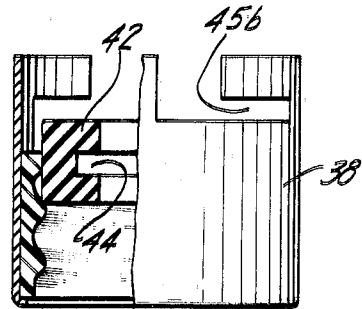

FIG. 3

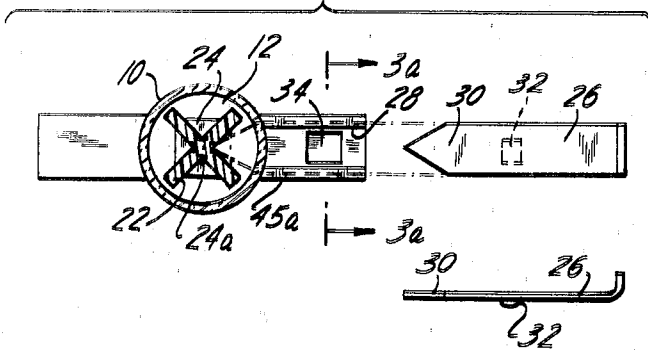

FIG. 3a

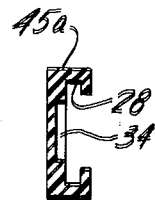

FIG. 4

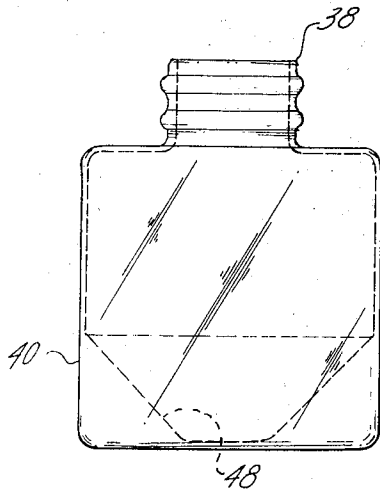

FIG. 7

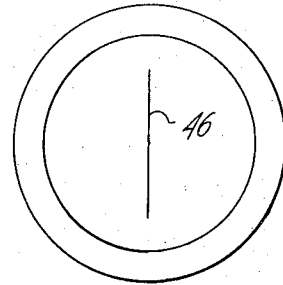
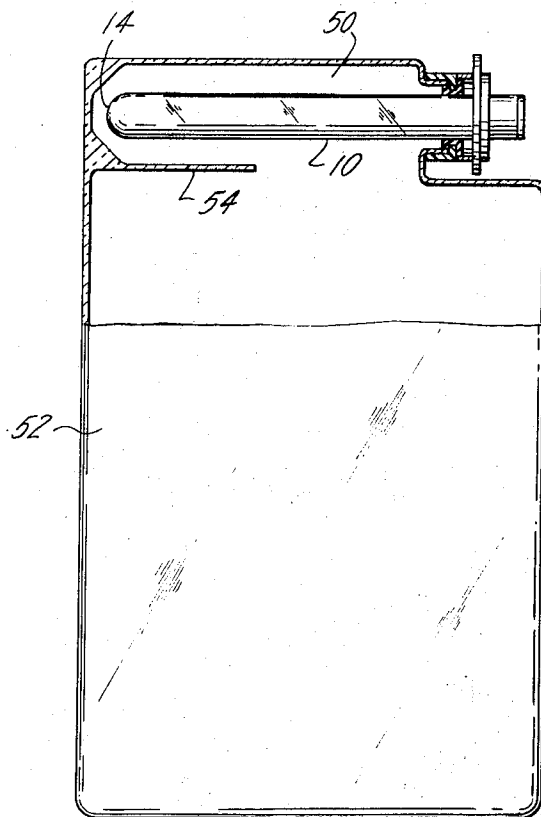

FIG. 8



DEVICE FOR THE ORAL ADMINISTRATION OF MEDICINE

BACKGROUND OF THE INVENTION

The present invention relates to a new and improved dispenser particularly adapted for the measuring and dispensing of relatively small amounts of fluids. More particularly, the instant invention relates to an improved dispenser for the oral administration of medication to particular classes of patients and under particular, adverse conditions. Included in its uses would be administration to patients, infants and blind persons, as well as to individuals travelling in a vibrating vehicle, e.g., an ambulance or airplane, whereby a means of imbibing a liquid medication without danger of spilling is needed. Similarly, it would be most useful for the dispensing of medication in the dark. Also, the present device would be of value in the veterinary arts inasmuch as the problem of administering liquid medication to an animal is, in a sense, not dissimilar from that of administration of medicine to an infant.

The present inventive effort is intended to overcome specific problems existant in the prior art. These problems include: (1) that, as above mentioned, of possible spilling of liquid medication, (2) that of obtaining the precise measurement of the desired quantity of the liquid medication, and (3) that of administering medication under a variety of stress conditions induced either by the condition of the patient or by a particular external environment. In addition, the present invention offers an approach wherein medication may be orally administered without fear that it may inadvertently be injected into the lungs of the patient.

The most pertinent art known in this field are the U.S. patents to W. J. Blease, No. 2,847,009, and to J. Schunk, No. 3,572,337. The Blease patent fails to come to grips with the problem of exactness in the measurement of the liquid withdrawn into the dispenser. Also, it fails to deal with the problem of spillage of medication, particularly during stress periods of administration. The Schunk patent suffers from similar shortcomings and additionally presents, as do most other known devices for oral administration, the danger of an accidental injection of the medication into the lungs of the patient. It is to be stressed that neither these patents, nor others known to the inventor, present a device which would be suitable either for use by a blind individual or for medicinal administration that would be adequate under various stress conditions of use. The instant invention can be viewed primarily as a response to these particular shortcomings in the existant techniques of oral medicinal administration.

It should also be noted that the device hereinafter described could, in a given case, be readily adapted to other forms of medicinal dispensing, such as rectal or vaginal.

SUMMARY OF THE INVENTION

An object of the present device is to provide a means for the oral administration of medicine.

Another object is to provide a means of the above class wherein a high degree of volumetric accuracy is obtainable.

Yet another object is to provide a device for the administration of medicine that is essentially spill-proof

and which, therefore, is suitable to use under a variety of stress conditions.

Still another object is to provide a device of the class described that is suitable for use by a blind person.

5 A still further object is to provide a device of said nature wherein the risk of an accidental injection of medication into the trachea of a patient is minimized, and wherein the danger of inadvertently aspirating the medication is eliminated.

10 The present invention comprises: an elongated hollow cylinder having an opening at one end and a plurality of apertures at the opposite end, said opposite end intended for placement into a pool of liquid medication; a reciprocating plunger slidably receivable within said cylinder, said plunger comprising: a forward portion having means for assuring an air- and liquid-tight fit between the circumferential periphery of said forward portion and the interior walls of said cylinder; and a shank portion having a radially projecting measuring shelf; and a slidable member supported in a radial plane near the open end of said cylinder, wherein said slidable member will, after a sufficient withdrawal of said plunger toward the open end of the cylinder, engage said measuring shelf, thereby securing a withdrawal into said cylinder of a predetermined volume of medication, the volume being a function of the longitudinal location of said measuring shelf on said shank portion of said plunger.

BRIEF DESCRIPTION OF THE DRAWINGS

FIG. 1 is a perspective view of the present invention.

FIG. 2 is a radial cross-sectional view of FIG. 1 taken along the line 2—2.

FIG. 3 is a radial cross-sectional view of FIG. 1 taken along the line 3—3.

FIG. 3a is a cross-sectional side view taken along line 3a of FIG. 3.

FIG. 4 is a perspective view of a first embodiment of a bottle for holding medicine, said bottle suitable for use in association with the present cylinder and plunger combination.

FIG. 5 is a top plan view of a cover for the bottle shown in FIG. 4.

FIG. 6 is a radial quarter cross-sectional view of FIG. 5 taken along the line 6—6, showing a press-fittable complementary resilient locking means.

FIG. 7 is an alternate embodiment of the cover of the medicine bottle.

FIG. 8 is a perspective view of an alternate embodiment of the medicine bottle shown with the cylinder and plunger inserted therein.

DETAILED DESCRIPTION OF THE INVENTION

The present device for the administration of medicine comprises an elongated hollow cylinder 10 (see FIG. 1) having an open end 12 (see FIG. 3) and an opposite end 14. Within the end 14 are disposed a plurality of small apertures 16. Said apertures 16 are, for reasons to be discussed subsequently, located primarily about the circumferential periphery of said opposite end 14. The end 14 is preferably formed in the shape of a dome. The purpose of the dome is to provide a smooth, rounded surface which will reduce the possibility of injury to delicate body surfaces with which it may come in contact.

Slidably receivable within said cylinder 10 is a reciprocating plunger 18. Said plunger 18 exhibits a forward portion 19 which is secured to the plunger 18 by a barbed structure 20. The portion 19 constitutes a means for assuring an air- and liquid-tight fit between the circumferential periphery of the forward portion 19 and the interior wall of the cylinder 10. Such an air- and liquid-tight fit is necessary in order to insure the integrity of the volumetric measuring function of the present invention.

Illustrated as element 21 is a circumferential recess into which the top of the plunger may be resiliently snapped. This feature enables the entire device to be stored without danger of dust or moisture entering the cylinder 10.

A shank portion 22 of the plunger 18 is provided with radially projecting measuring shelves 24, each having a corresponding slot 24a in the plunger immediately above each shelf (see FIG. 2). The shelves are shown in plan view in FIG. 2. While the shelves 24 are illustrated in a single plane in the drawings, it is to be understood that a plurality of shelves may be equally suitable to particular applications of the instant invention. Also, an alternate embodiment of the shelves 24 would provide for their slidable attachment to the shank portion 22. In such an embodiment the shank 22 would be calibrated in units of volume. A user of the instant device would simply slide the shelves 24 to the desired volumetric unit as indicated by said calibrations on said shank 22.

The shelves 24, in whichever of the aforescribed embodiments they are utilized, operate in conjunction with a slidable member 26 (see FIG. 3). Said slidable member 26 is supported in a radial plane near the open end 12 of the cylinder 10. In operation the slidable member 26 is inserted into a groove 28 (see FIG. 3a) and advanced until its forward region 30 passes through an opening in the wall of the cylinder 10, locking a male notch 32 into a female notch 34 (see FIG. 3), thereby covering a radial segment of the open end 12 and engages the slot 24a. In order to fill the cylinder to the proper volumetric level, the end 14 is simply inserted into a pool of the desired medicine and the plunger is then withdrawn toward the open end 12 until the shelves 24 make contact with the slidable member 26.

The engagement of the forward region 30 into the slot 24a assures that an individual administering a drug to himself or to another will not inadvertently discharge a quantity of the medicine before he desires to do so. In summary, whereas the slidable member 26 assures that precisely the desired quantity of medication will be extracted and accumulated through the holes 16, the slot 24a assures that this precise quantity of medicine will remain inside of the cylinder until immediately prior to its discharge into the mouth of a patient. This feature is of particular significance when an oral administration of medicine is attempted under stress conditions such as while in a moving vehicle or in the administration of a drug to an infant, to one who is violently ill, or to an animal.

As a further safety measure, the end 14 of the cylinder may be provided with a snap on cap which would cover the holes 16 after the cylinder has been filled with medicine but prior to its administration.

The cylinder 10 should be constructed out of a material having the properties of resilience and unbreakabil-

ity. One example of such material would be the plastic polypropylene. The construction of the cylinder 10 from such a material is necessary in order to assure that the patient whom, as aforesaid, may be using the present device under stress conditions, does not inadvertently bite on the cylinder and thereby injure himself. Through the use of a material such as polypropylene, a child, particularly one of young age, would not be exposed to the slightest risk of injury in the use of the present device.

The placement of the holes 16 about the circumferential periphery or base of the dome-like end 14 of the cylinder serves the function of dramatically reducing the probability that any of the discharged medication may accidentally be forced into a patient's lungs. By locating the holes primarily in a circumferential location, the medicine, when discharged, will be forced towards the inside of the patient's cheeks where it can then be swallowed in a natural fashion.

The present medicinal administration device is suitable for use with a number of different types of medicine bottles. FIG. 4 illustrates a relatively conventional type of bottle to which certain modifications have been made in order to facilitate its use with the present device. These modifications include a first cover 38 for the mouth of the bottle 40. A variety of embodiments of said first cover 38 are equally suitable to the present application. FIGS. 5 and 6 illustrate one such embodiment. In this embodiment, a rubber washer 42 is secured within the cover 38. Said washer has a cylindrical hollow in its center. Formed within the washer 42 is a circumferential groove 44. This groove 44 serves as a means for the press fitable insertion of the cylinder 10 into the mouth of the bottle. In this embodiment, the cylinder 10 is provided with a circumferential protrusion 46 which is complementary to the circumferential groove 44. When snapped into the groove 44, the protrusion 46 constitutes a liquid- and air-tight seal between the contents of the bottle and the outside environment.

The circumferential groove 44 may be held within a cover which is secured to the top of the mouth of the bottle. Alternatively, said first cover 38, with its associated washer 42 and circumferential groove 44, may comprise an integral part of the interior of the mouth of the bottle. Alternatively, said first cover 38, with its associated washer 42 and circumferential groove 44, may comprise an integral part of the interior of the mouth of the bottle. In either embodiment the bottle is provided with a second cover which is a storage cover that is secured over said first cover 38 when the bottle is not in use.

A further feature shown in FIG. 6 is a means for assuring that the cylinder 10 is mechanically locked into the bottle cap 38. Said means comprises a rectangular edge 45a (see FIGS. 1 and 3) which is complementary and slidably lockable into a groove 45b.

FIG. 7 illustrates yet another embodiment of the cover of the bottle. In this embodiment the cover is provided with a diametric slit 46. This diametric slit 46 is deformable. Its normal condition is one of a closed air- and liquid-tight seal. However, upon application of a sufficient amount of pressure, it will deform to a cross-sectional area equal to that of the cross-sectional area of the cylinder 10. Said deformability permits the ready ingress and egress of said cylinder 10.

The bottle 40 may be provided with an interior base having substantially the form of an inverted cone with a rounded apex 48.

Finally, a novel embodiment of a medicine holding bottle is shown in FIG. 8. This embodiment is a bottle whose interior comprises a first chamber 50 and a second chamber 52. The first chamber is smaller than the second chamber and is partially separated therefrom by a wall 54. The mouth of the bottle is in the first chamber 50. Also, said first chamber has a longitudinal axis which runs parallel to said wall. It is through the mouth of the bottle and along said longitudinal axis that the cylinder 10 is insertable. The necessary volume of medicine needed to fill the cylinder is transferred from the second chamber 52 to the first chamber 50 by way of a rotation of between 90° and 180° of said bottle.

The bottles 40 and 52 are preferably formed of a material that is resilient and unbreakable. The aforescribed combination of a device for the administration of medicine in conjunction with a variety of medicine-holding bottles constitutes an apparatus with which an individual suffering from any of several physical impediments, for example blindness, can, after the measuring shelves have once been adjusted by another individual, easily execute the administration of medication to himself without the need of any additional help. Similarly, the described combination is singularly suited to use while travelling in moving vehicles such as cars, ambulances, trains, and airplanes, or when operating in the dark.

In summary, the possibility of a spill of the medication has been eliminated. Total accuracy has been insured. The danger of discharge of the medication into the patient's lungs has been greatly reduced, and the danger of breakage of either the medicine bottle or the administration cylinder has been eliminated.

It is thus seen from the above that the objects set forth in the summary of the invention are among those made apparent from and efficiently attained by the device for the oral administration of medicine of the preceding description.

I wish it to be understood that I do not desire to be limited to the exact detail of construction shown and described, for obvious modification will occur to persons skilled in the art.

Having thus described my invention, what I claim as new, useful, and non-obvious and accordingly, with this instrument, secure by letters patent of the United States is:

1. A device for the oral administration of medication, comprising:

- a. an elongated hollow cylinder having an opening at one end and a plurality of apertures at an opposite end, said opposite end intended for placement into a pool of liquid medication, said cylinder also having a side wall opening;
- b. a reciprocating plunger received within said cylinder, said plunger comprising:
 - i. a forward portion having means for assuring an air- and liquid-tight fit between the circumferential periphery of said forward portion and the interior walls of said cylinder; and
 - ii. a shank portion having a radially projecting measuring shelf;
- c. a slidable member supported by a radial plane element near the open end of said cylinder, wherein said slidable member will, after a sufficient with-

drawal of said plunger toward the open end of the cylinder, pass through said side wall opening and engage said measuring shelf, thereby securing a withdrawal into said cylinder of a predetermined volume of medication, the volume being a function of the longitudinal location of said measuring shelf on said shank portion of said plunger;

d. a bottle for holding medicine, said bottle having a mouth; and

e. a cover connected to said mouth, said cover having an opening therein, said opening comprising means receiving said cylinder and for attaining a press-fit insertion of said cylinder into said opening, wherein said press-fit is both liquid- and air-tight, said receiving means itself comprising a partially circumferential female slot for receiving said radial plane element of said cylinder.

2. The device as recited in claim 1 in which said means for press-fit insertion comprises a deformable diametric slit, said slit having a normally closed state, said slit being deformable to a degree that permits the ingress and egress of said cylinder.

3. The device as recited in claim 1 in which said first cover is an integral communication with the interior of said mouth.

4. The device as recited in claim 3 in which the interior base of said bottle has substantially the form of an inverted cone with a rounded apex.

5. The device as recited in claim 1 in which the interior of said bottle comprises a first chamber and a second chamber, said first chamber being smaller than said second chamber and partially separated therefrom by a wall, said first chamber having an opening therein, said opening comprising said mouth of said bottle; and said first chamber further having a longitudinal axis running parallel to said wall along which said cylinder is insertable; said first chamber yet further having, at the end of the longitudinal axis opposite the said mouth, a surface having substantially the form of an inverted cone with a rounded apex, whereby a portion of medicine may be transferred from said second chamber to said first chamber by a rotation of between 90° and 180° of said bottle.

6. The device as recited in claim 4 in which the material of said bottle is resilient and unbreakable.

7. The device as recited in claim 5 in which the material of said bottle is resilient and unbreakable.

8. A device for the oral administration of medication, comprising:

- a. an elongated hollow cylinder having an opening at one end and a plurality of apertures at an opposite end, said opposite end intended for placement into a pool of liquid medication, said cylinder also having a sidewall opening;
- b. a reciprocating plunger received within said cylinder, said plunger comprising:
 - i. a forward portion having means for securing an air- and liquid-tight fit between the circumferential periphery of said forward portion and the interior walls of said cylinder; and
 - ii. a shank portion having a radially projecting measuring shelf;
- c. a slidable member supported in a radial plane near the open end of said cylinder, wherein said slidable member will, after a sufficient withdrawal of said plunger toward the open end of the cylinder, pass through said side wall opening and engage said

7

measuring shelf, thereby securing a withdrawal into said cylinder of a pre-determined volume of medication, the volume being a function of the longitudinal location of said measuring shelf on said shank portion of said plunger;

d. a bottle for holding medication said bottle having a mouth, the interior of said bottle comprising a first chamber and a second chamber, said first chamber being smaller than said second chamber and partially separated therefrom by a wall, said first chamber having an opening therein, said opening comprising said mouth of said bottle, said first

8

chamber further having a longitudinal axis running parallel to said wall along which said cylinder is insertable, and

e. a cover connected to said mouth, said cover having an opening therein, said opening comprising means receiving said cylinder and attaining a press-fit insertion of said cylinder into said opening wherein said press-fit is both liquid-and air-tight.

9. The device as recited in claim 8 in which the material of said bottle is resilient and unbreakable.

* * * * *

15

20

25

30

35

40

45

50

55

60

65