

(19) AUSTRALIAN PATENT OFFICE

(54) Title
System and method for calcination/carbonation cycle processing

(51)⁶ International Patent Classification(s)
B01D 53/62 (2006.01) ^{6BHAU} B01J
B01J 20/34 (2006.01) 20/34
B01D 53/62 20060101ALI2007042
20060101AFI2007042 ^{6BHAU}
PCT/AU2006/001568

(21) Application No: 2006303828 (22) Application Date: 2006 .10 .23

(87) WIPO No: W007/045048

(30) Priority Data

(31) Number	(32) Date	(33) Country
2006902293	2006 .05 .03	AU
2005905810	2005 .10 .21	AU
2006901658	2006 .03 .31	AU
2006901994	2006 .04 .18	AU
2006904553	2006 .08 .22	AU
2006900546	2006 .02 .06	AU

(43) Publication Date : 2007 .04 .26

(71) Applicant(s)
Calix Limited

(72) Inventor(s)
Sceats, Mark Geoffrey; Horley, Connor James

(74) Agent/Attorney
Spruson & Ferguson, Level 35 St Martins Tower 31 Market Street, Sydney, NSW, 2000

(56) Related Art
WO 2005/046862
US 2005/0060985
WO 2000/48709

(12) INTERNATIONAL APPLICATION PUBLISHED UNDER THE PATENT COOPERATION TREATY (PCT)

(19) World Intellectual Property Organization
International Bureau



(43) International Publication Date
26 April 2007 (26.04.2007)

PCT

(10) International Publication Number
WO 2007/045048 A1

- (51) International Patent Classification:
B01D 53/62 (2006.01) *B01J 20/34* (2006.01)
- (21) International Application Number:
PCT/AU2006/001568
- (22) International Filing Date: 23 October 2006 (23.10.2006)
- (25) Filing Language: English
- (26) Publication Language: English
- (30) Priority Data:
2005905810 21 October 2005 (21.10.2005) AU
2006900546 6 February 2006 (06.02.2006) AU
2006901658 31 March 2006 (31.03.2006) AU
2006901994 18 April 2006 (18.04.2006) AU
2006902293 3 May 2006 (03.05.2006) AU
2006901553 22 August 2006 (22.08.2006) AU
- (71) Applicant (for all designated States except US): CALIX
PTY LTD [AU/AU]; 102/38 Refinery Drive, Pyrmont,
NSW 2009 (AU).
- (72) Inventors; and
(75) Inventors/Applicants (for US only): SCEATS, Mark,
- Geoffrey [AU/AU]; 102/38 Refinery Drive, Pyrmont,
NSW 2009 (AU). HORLEY, Connor, James [AU/AU];
2/183 Musgrave Avenue, Southport, QLD 4215 (AU).
- (74) Agent: SPRUSON & FERGUSON; GPO Box 3898, Syd-
ney, NSW 2001 (AU).
- (81) Designated States (unless otherwise indicated, for every
kind of national protection available): AE, AG, AL, AM,
AT, AU, AZ, BA, BB, BG, BR, BW, BY, BZ, CA, CH, CN,
CO, CR, CU, CZ, DE, DK, DM, DZ, EC, EE, EG, ES, FI,
GB, GD, GE, GI, GM, GT, HN, HR, HU, ID, IL, IN, IS,
JP, KE, KG, KM, KN, KP, KR, KZ, LA, LC, LK, LR, LS,
LT, LU, LV, LY, MA, MD, MG, MK, MN, MW, MX, MY,
MZ, NA, NG, NI, NO, NZ, OM, PG, PH, PL, PT, RO, RS,
RU, SC, SD, SE, SG, SK, SL, SM, SV, SY, TJ, TN, TR,
TT, TZ, UA, UG, US, UZ, VC, VN, ZA, ZM, ZW.
- (84) Designated States (unless otherwise indicated, for every
kind of regional protection available): ARIPO (BW, GH,
GM, KE, LS, MW, MZ, NA, SD, SI, SZ, TZ, UG, ZM,
ZW), Eurasian (AM, AZ, BY, KG, KZ, MD, RU, TJ, TM),
European (AT, BE, BG, CH, CY, CZ, DE, DK, EE, ES, FI,

[Continued on next page]

(54) Title: SYSTEM AND METHOD FOR CALCINATION/CARBONATION CYCLE PROCESSING

WO 2007/045048 A1

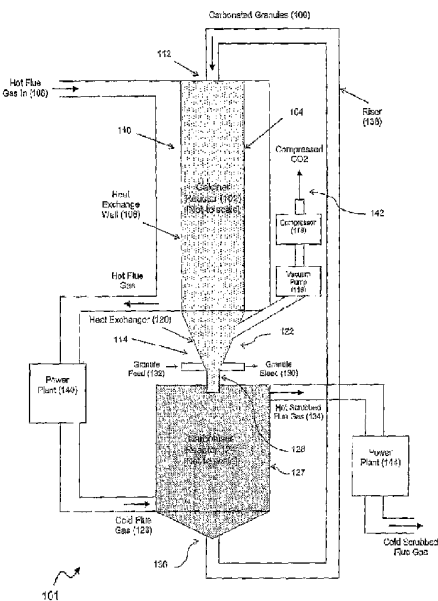

(57) Abstract: A system and method for calcination/carbonation cycle processing. The system comprises a calciner reactor for receiving partially carbonated mineral sorbent granules; a heat exchange structure for transferring heat through a wall of the calciner reactor to a granular flow of the sorbent granules for facilitating a calcination reaction of the sorbent granules to regenerate the sorbent granules; a gas extraction unit for removing gas products from the calciner, wherein the gas products comprise carbon dioxide from the calcination reaction; a carbonator reactor for receiving the regenerated sorbent granules from the calciner reactor and for receiving a cold flue gas, such that the regenerated sorbent granules are partially carbonised while the flue gas is scrubbed and the partially carbonated sorbent granules and the scrubbed flue gas exit the carbonator reactor as respective hot materials; and a riser unit for cycling the partially carbonated sorbent granules from the carbonator reactor to the calciner reactor.



FR, GB, GR, HU, IE, IS, IT, LU, LV, MC, NL, PL, PT,
RO, SE, SI, SK, TR), OAPI (BI, BJ, CI, CG, CL, CM, GA,
GN, GQ, GW, ML, MR, NE, SN, TD, TG).

For two-letter codes and other abbreviations, refer to the "Guidance Notes on Codes and Abbreviations" appearing at the beginning of each regular issue of the PCT Gazette.

Published:

— with international search report

System And Method For Calcination/Carbonation Cycle Processing

5 FIELD OF INVENTION

The present invention relates broadly to a system and method for calcination/carbonation cycle processing.

10 BACKGROUND

The environmental impact of anthropogenic carbon dioxide emissions, which are currently at about 23.4 Gtonne, is now recognised to be a major risk to mankind.

15 Carbon Capture and Sequestration (CCS) processes aim to reduce CO₂ emissions by capturing CO₂ from industrial processes, principally in the power, cement, and steel processes, that burn fossil fuels, and sequestering the CO₂ in deep saline aquifers, depleted oil and gas fields, deep coal seams, or deep ocean reservoirs.

There are three approaches to carbon capture for the CCS application – post-combustion capture, pre-combustion capture and oxy-fuel combustion. Pre-combustion 20 capture would be used, for example, in an Integrated Gasification Combined Cycle power plant. However, the initial capital costs of a power plant based on this approach are believed to be very high. Oxy-fuel combustion uses oxygen instead of air, but suffers from the very high cost of separating oxygen from air, and may never be commercially viable. Post-combustion capture is believed to be the most promising CCS 25 process, with the benefit of being more easily integrated into existing power generation systems.

The transport, sequestration and monitoring of CCS are both well established, and their costs are not a hurdle to the adoption of CCS. However, there is currently no established carbon capture process that has been shown to be economically viable for 30 CCS. Only one carbon capture process is commercially used. This process, called the MEA process, is currently used by the petroleum industry to separate CO₂ from natural gas, where the CO₂ has been injected into the reservoir to force out the hydrocarbons. The MEA process separates the natural gas from the CO₂, and regenerates the MEA

sorbent for a cyclic process. MEA uses amines (and similar materials) as the sorbent, and the reverse process uses steam to release the CO₂ to regenerate the amine. The MEA process could operate today as a post combustion process in a power plant at a cost of US\$50-70 per tonne of CO₂ avoided, well in excess of the target of US\$10-20 per tonne of CO₂ avoided, as required for the CCS application. MEA cannot be currently used in its present form because it consumes too much energy from the power plant. MEA is a toxic material. Thus there is a world-wide effort to develop new carbon capture technologies that can meet the long term cost target for CCS.

Shimizu et al. (T. Shimizu, T. Hiram, H. Hosoda, K. Kitano, "A twin bed reactor for removal of CO₂ from combustion processes", *Trans I Chem E*, 77A, 1999) first proposed that a calcination/carbonation cycle be used to capture carbon from flue gases. The paper by Shimizu et al. proposes limestone carbonation at 600°C for capturing the carbon from the flue gas, and regeneration of CaCO₃ above 950°C by burning fuel with the CaCO₃, akin to conventional calcination, with pure oxygen from a separating plant, so as to give pure CO₂ and steam as an output. However, this approach is impractical, and limestone calcined above 950°C will rapidly lose its reactivity due to sintering, as was demonstrated in the work of Shimizu.

Abandades and Alvarez ("Conversion Limits in the Reaction of CO₂ with Lime", *Energy & Fuels*, 2003,17, 308-315) presented additional data and reviewed previous work on the Calcium calcination/carbonation cycle. They demonstrated that the fast reaction observed by all researchers was due to the calcination and carbonation of surfaces in micropores of the CaO, which are refilled in carbonation, and a smaller contribution from calcination and carbonation on the larger surfaces. Repeated sintering of the particles during the calcination cycles caused a gradual change in the morphology of the particles with a loss of the micropores, resulting in a loss of the fast component of the carbonation and a degradation of the sorbent.

Garcia et al. (A Garcia, J Carlos and J. Oakey; "Combustion method with integrated CO₂ separation by means of carbonation" US Patent publication no. 20050060985) described a process that uses this cycle. They claim a system based on a fluid circulating fluid bed reactor, drawn bed reactor, or cyclone reactor. Their patent discloses that heat transfer from the combustion reactor provides heat to the calciner, and the use of a partial vacuum or steam in the operation of the calciner. They specify a calcination temperature of 900°C and a carbonation temperature between 600-750°C.

They report that the replenishment of the sorbent is 2-5%, so that, on average, the limestone is cycled between 50 and 20 times.

5 The practical problems with this approach arise firstly from the lifetime of the reactivity of the granules. It is understood that the granules will react with the SO_x contaminants in flue gases to produce CaSO₃, which is later oxidised to gypsum CaSO₄. The injection of limestone granules into hot flue gases to scrub the SO_x is an existing technique referred to as "furnace sorbent injection". In addition, the limestone granules lose reactivity at high temperature in the calcination stage due to sintering. The calciner described by Garcia et al is a fluidized bed to take advantage of the high heat transmission coefficients. Alternatively, a pneumatic transported bed of pipes is described through which the steam is made to pass. The results of A. Abanades and D. Alvarez, Energy and Fuels, 2003, 17, 309-315, shows how the performance of a material that is produced (and later recycled) through 10 minute long calcination steps degrades. The cumulative sintering not only reduces the surface area but closes the pores.

15 L-S Fan and H.Gupta (US Patent publication no. 20060039853) also described a carbon capture process by limestone using the calcination/carboation sorption cycle for application in the water gas shift reaction to promote plants hydrogen generation in the water gas shift reaction. They describe the use of a material described in a previous patent (US 5,779,464) as a "super sorbent" as characterised by a high surface area and of 25 m² gm⁻¹ and a pore volume of 0.05 cm³ gm⁻¹, and a mesoporous pore size distribution in the range of 5-20 nm diameter. Their objective was to make a limestone with a surface that mitigates the effect of "pore clogging", namely one that has a mesoporous structure, rather than a microporous structure with pores <2nm.

20 A critical factor in the assessment of the viability of a CCS system is the energy, capital and operating costs of the processes and the footprint of the capture systems. The energy cost for an efficient regenerable sorbent system is largely determined by the integration of the process into the thermal processes of the power plants or industrial processes and is determined by the recuperation of heat, because the chemical energy of sorption and desorption is recovered. However, any ancillary processes that consume energy such as transfer of granules between reactors would create a penalty. The capital cost translates into the cost of the process, and simple scalable reactor designs are required. The operating costs include the cost of feedstock, and the

sorbents used should have a long lifetime and should preferably, be a low cost to manufacture. The operating costs also include the cost of disposal of the spent sorbent, and preferably this should be non-toxic and a waste product that can be profitably consumed. It is understood that a major concern in developing a practical CCS system is the footprint of the reactor systems. Some concepts, when scaled, lead to a CCS system that is as large as the power generator.

A need therefore exists to provide a system and method for calcination/carbonation cycle processing that seeks to address at least one of the above mentioned problems.

SUMMARY

It is an object of the present invention to substantially overcome, or at least ameliorate, one or more disadvantages of existing arrangements.

According to a first aspect of the present invention there is provided a system for calcination/carbonation cycle processing, the system comprising a calciner reactor for receiving partially carbonated mineral sorbent granules, the calciner reactor arranged such that the sorbent granules move through the calciner reactor under gravitational forces in a granular flow; a heat exchange structure for transferring heat through a wall of the calciner reactor to the granular flow of the sorbent granules for facilitating a calcination reaction of the sorbent granules to regenerate the sorbent granules; a gas extraction unit for removing gas products from the calciner, wherein the gas products comprise carbon dioxide from the calcination reaction; a carbonator reactor for receiving the regenerated sorbent granules from the calciner reactor and for receiving a cold flue gas, such that the regenerated sorbent granules are partially carbonised while the flue gas is scrubbed and the partially carbonated sorbent granules and the scrubbed flue gas exit the carbonator reactor as respective hot materials; and a riser unit for cycling the partially carbonated sorbent granules from the carbonator reactor to the calciner reactor.

The calciner reactor may comprise a feeder unit for the granules; a retort chamber having the feeder unit located at a top portion thereof, whereby the sorbent granules move through the retort chamber under gravitational forces in a granular flow; and the heat exchange structure is thermally coupled to a wall of the retort chamber for providing heat to the granules inside the retort chamber through heat transfer through the wall of the retort chamber.

The riser unit may pneumatically cycle the partially carbonated sorbent granules from a base of the carbonator reactor to the feeder unit at the top of the retort chamber.

5 The system may further comprise a mixer means disposed inside the retort chamber, the mixer means imparting at least horizontal forces on the granules moving through the chamber such that the granules are moved towards the wall of the retort chamber for facilitating the heat exchange to the granules through the wall of the retort chamber.

10 The gas extraction unit may comprise a gas/particles separator structure disposed inside the calcination reactor and coupled to exhaust openings of the retort chamber for facilitating separation of the gas products from the granules.

15 The gas extraction unit may comprise a vacuum pump for removing the gas products from the calciner reactor.

A gas used to pneumatically cycle the granules from the carbonator to the calciner may be steam.

20 The calciner reactor may comprise a plurality of retort chambers, each retort chamber comprising a feeder unit located at a top portion of said each retort chamber, whereby the granules move through said each retort chamber under gravitational forces in a granular flow; the heat exchange structure is thermally
25 coupled to a wall of said each retort chamber for providing heat to the sorbent granules inside said each retort chamber through heat transfer through the wall of said each retort chamber; and the gas extraction unit removes the gas products from said each retort chamber.

30 The system may comprise a plurality of carbonator reactors, wherein the regenerated sorbent granules are fed serially through the plurality of carbonator reactors.

The system may further comprise a bleed unit for bleeding a portion of the calcinated granules from the calciner reactor prior to the carbonator reactor, and a feed unit for feeding a corresponding portion of fresh calcinated granules into the carbonator reactor.

The sorbent granules may have a size distribution between about 40 microns to about 125 microns.

The system may further comprise means for scrubbing dust from the gas products comprising the carbon dioxide.

The system may further comprise means for cooling the gas products comprising the carbon dioxide.

The system may further comprise means for compressing the gas products comprising the carbon dioxide.

According to a second aspect of the present invention there is provided a method for calcination/carbonation cycle processing, the method comprising the steps of receiving partially carbonated mineral sorbent granules in a calciner reactor; providing for movement of the sorbent granules through the calciner reactor under gravitational forces in a granular flow; transferring heat through a wall of the calciner reactor to the granular flow of the sorbent granules for facilitating a calcination reaction of the sorbent granules to regenerate the sorbent granules; removing gas products from the calciner, wherein the gas products comprise carbon dioxide from the calcination reaction; receiving the regenerated sorbent granules from the calciner reactor and a cold flue gas in a carbonator reactor, such that the regenerated sorbent granules are partially carbonised while the flue gas is scrubbed and the partially carbonated sorbent granules and the scrubbed flue gas exit the carbonator reactor as respective hot materials; and cycling the partially carbonated sorbent granules from the carbonator reactor to the calciner reactor.

The calciner reactor may comprise a feeder unit for the granules; a retort chamber having the feeder unit located at a top portion thereof, whereby the sorbent granules move through the retort chamber under gravitational forces in a granular

flow; and the heat exchange structure is thermally coupled to a wall of the retort chamber for providing heat to the granules inside the retort chamber through heat transfer through the wall of the retort chamber.

5 The partially carbonated sorbent granules may be pneumatically cycles from a base of the carbonator reactor to the feeder unit at the top of the retort chamber.

The method may further comprise imparting at least horizontal forces on the granules moving through the chamber such that the granules are moved towards
10 the wall of the retort chamber for facilitating the heat exchange to the granules through the wall of the retort chamber.

The method may comprise utilising a gas/particles separator structure disposed inside the calcination reactor and coupled to exhaust openings of the retort
15 chamber for facilitating separation of the gas products from the granules.

The method may comprise utilising a vacuum pump for removing the gas products from the calciner reactor.

20 A gas used to pneumatically cycle the granules from the carbonator to the calciner may be steam.

The calciner reactor may comprise a plurality of retort chambers, each retort chamber comprising a feeder unit located at a top portion of said each retort
25 chamber, whereby the granules move through said each retort chamber under gravitational forces in a granular flow; the heat exchange structure is thermally coupled to a wall of said each retort chamber for providing heat to the sorbent granules inside said each retort chamber through heat transfer through the wall of
30 said each retort chamber; and the gas extraction unit removes the gas products from said each retort chamber.

The method may comprise utilising a plurality of carbonator reactors, wherein the regenerated sorbent granules are fed serially through the plurality of carbonator reactors.

The method may further comprise bleeding a portion of the calcinated granules from the calciner reactor prior to the carbonator reactor, and feeding a corresponding portion of fresh calcinated granules into the carbonator reactor.

5

The sorbent granules may have a size distribution between about 40 microns to about 125 microns.

The method may further comprise scrubbing dust from the gas products comprising the carbon dioxide.

10

The method may further comprise cooling the gas products comprising the carbon dioxide.

15

The method may further comprise compressing the gas products comprising the carbon

BRIEF DESCRIPTION OF THE DRAWINGS

Embodiments of the invention will be better understood and readily apparent to one of ordinary skill in the art from the following written description, by way of example only, and in conjunction with the drawings, in which:

20

Figure 1 shows a schematic vertical cross-sectional drawing of a calciner/carbonator reactor for calcination/carbonation cycle processing according to an example embodiment.

25

Figure 2 shows a schematic horizontal cross-sectional view of a static mixer structure inside the calciner reactor of Figures 1 in another embodiment.

Figure 3 shows a schematic vertical cross-sectional view of a gas/particle separator structure for use inside the calciner reactor of Figure 1 in another embodiment.

30

Figure 4 is a schematic representation of a carbon capture system based on an array of calciner and carbonator reactors of the type described in Figure 1 that may be deployed in a power station with desulphurator reactors.

Figure 5 shows a flow chart illustrating a method for calcination/carbonation cycle processing.

DETAILED DESCRIPTION

The described embodiments relate to a method for separating CO₂ and SO_x from combustion gases using lime granules as the feedstock in a regenerative sorbent process. The embodiments described herein use as a common feature the calcination/carbonation cycle to remove the carbon dioxide using the reactions based on a metal oxide MO(s) sorbent. The chemical reactions that comprise the cycle are:-

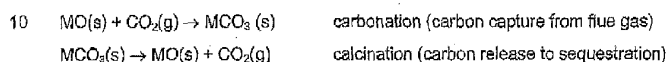

The embodiments are based on a reactor system in which the granules are pneumatically transported between the carbonator reactor through which flows the flue gases and a calciner in which the sorbent is regenerated and the released carbon dioxide is scrubbed, if required, and mechanically compressed for sequestration.

The embodiments assume that the initial feedstock is preferably a "super sorbent" prepared using a steam catalytic calciner, but other methods of feedstock preparation are known in the art.

The embodiments further assume that the particles are spent through the reaction with SO_x such that the end product, is a MSO₄ after oxidation. Thus the embodiments relate to a reactor system that is appropriate to removal of both CO₂ and SO_x from flue gases.

The reactors described herein are appropriate to the use of calcium or magnesium (that is M = Ca or Mg). The calcium calcination/carbonation reaction operates at 900-950°C for calcination and 600-750°C for carbonation, whereas the magnesium calcination/carbonation reaction operates at 500-550°C for calcination and 300-400°C for carbonation. For the magnesium cycle, the sorbent may be magnesia MgO or a new material MgO.CaCO₃, referred to herein by the trademark semidolime, or a mixture thereof. It is understood that reference to the new material using the trademark semidolime in the provided description is not to be viewed as making that name a generic description of the new material. For the calcium cycle, lime CaO is preferably used. The advantages of using semi-dolime as the sorbent are principally the cost of dolomite compared to magnesite, but also the pore clogging of semi-dolime is reduced

by the "dilution" of the surface active MgO sites by the inactive CaCO₃ sites. The sorption efficiency of semidolime is limited to 0.31 kg of CO₂ per kg of MgO.CaCO₃ sorbent compared to the extraordinary capacity of 1.09 kg of CO₂ per kg of MgO sorbent. By comparison with lime as sorbent, the cost of lime is less than dolomite, and limestone is already extensively used in power stations for SO_x reduction. A calcium calcination/carbonation cycle can operate with no net increase in feedstock cost because the regenerative carbon capture cycle uses the lime many times before it is poisoned by the SO_x. For calcium sorbents the temperatures are higher and the enthalpies of reaction are higher than the magnesium sorbents, and thus the integration of the calcium cycle into an industrial process may be more difficult and expensive, whereas the magnesium cycle is potentially more adaptable.

The embodiments described herein are essentially the same for both calcium and magnesium based sorbents, and persons skilled in the art would appreciate the differences that are required. For example, those parts of the system continuously exposed to temperatures above 900°C would be fabricated from alloys that were resistant at those temperatures, whereas the materials used at 650°C would be lower cost, for example stainless steel.

A key challenge to the adoption of calcination/carbonation to carbon capture is likely to be the capital cost and footprint of the systems used for example, in a power plant. The embodiments described herein use a design in which these two parameters are reduced compared to existing techniques.

The described method uses a calcination process that seeks to minimise the residence time of the granules in the calciner reactor. There are two important consequences of this principle. Firstly the volume of the calciner/carbonator reactor system scales with the residence time in the reactor, for a given sorption efficiency. This is particularly important in the development of sorbent reactors that deal with the large carbon dioxide output of power stations and other large industrial processes. This will also be reflected in the capital cost and the footprint of the system. Secondly, the deleterious effects that arise from sintering of the granules scales with the cumulative residence time in the high temperature calciner reactor.

The described method also seeks to minimise the footprint of the reactor by using a slim gravity fed calciner module in which the residence time is between 1-10 seconds. Such a reactor would be 12-36 m high and would be such that the gravitational fall of a stream of granules, extended by mixer segments, has this residence time. The

heat transfer into this reactor occurs through the walls of the retort, and relies on the high viscosity of the granular flow. The solids fraction of the flow has to be sufficient that the flow develops, but should not be too high that the heat transfer rate, most generally limited by heat transfer through the calciner walls, limits the conversion efficiency during the residence time. The advantage of using gravity to transport the granules is that it is low cost, and the handling of granules using pneumatics is understood.

The described method is applicable to the removal of CO₂ from flue gasses or from other discharges from industrial processes.

The described embodiments further provide a process of separating SO_x and fly ash from the flue gas using said granules in separate desulphonator reactors that use as its feedstock the spent granules from the array of calciner/carbonator reactors, and which capture the SO_x, fly ash and other pollutants before the flue gases enter the calciner/carbonator reactors described herein. The design of such a desulphonator reactor is understood, and is not further described in this method. This method ensures that the granules in the calciner/carbonator reactors can be cycled to capture carbon dioxide for the maximum number of cycles before they become poisoned by residual SO_x or they lose reactivity by the cumulative sintering.

The described embodiments deal with the separation of the CO₂ using the calcination and carbonation process in an array of coupled calciner/carbonator reactors, extracting the heat from gas streams exiting the reactors, and collecting the CO₂ for re-use and/or for containment in geological formations known as sequestration. The scaling of the reactors in an array facilitates managing the heat flows between the reactors, a result that derives from the use of the viscosity of the granular flow to cause heat transfer across the calciner walls.

In the described embodiments for a single calciner/carbonator reactor, the calcination is undertaken on partially carbonated granules in which the carbonation is on the surfaces of the granules, including the filled micropores and mesopores. The use of steam catalysis that is preferably used to fabricate the sorbent is not required in the described embodiments because the reaction takes place sufficiently quickly because the carbonised regions occur at surface regions of the granules. It may be preferred to minimise the use of steam on the basis of cost. The reaction rate for calcination and carbonation slows down considerably as the reaction front moves into the deeper reaches of the particles. The granule surface area S(x) evolves during the calcination

reaction through the degree of conversion x . Khinast et al demonstrated that their results could be modelled by a random pore distribution that evolves as:

$$S(x) = S_0 (1-x)^{1.7} (1-37 \ln(1-x))^{0.69} \text{ m}^2/\text{kmol}$$

where S_0 is the BET surface area in m^2/kmol at $x=0$. This function initially increases as the departing carbon dioxide creates pores, and then decreases as the reaction zone approaches the core. It has been recognised by the inventors that, given the imperative to minimise the reactor residence time, it is more effective to only partially carbonate the granules and in each cycle use the initial fast calcination process to release the carbon dioxide. This approach sacrifices the very high sorption efficiency of the granules for other benefits. Thus, it has been recognised by the inventors that the degree of carbonation of the particles α^* can be set to the range of 30-50% in the described calcination/carbonation process such that the calcination proceeds from $x=1$ to $x=\alpha^*$. In this regime, the average value of $S(x)$ exceeds unity.

Figure 1 shows a calciner and carbonator reactor pair. However, it is noted that a carbonator reactor can more generally be fed by a number of calciner reactors in different embodiments so that the flue gas handling is optimised. Referring to Figure 1, carbonised granules at numeral 100 with a size distribution between about 40 microns to about 125 microns are injected into a calciner reactor 102, where the granules fall through the about 12m length and are regenerated by calcination. The calciner retort is the inner tube 104 of the reactor 102, and the heat for the endothermic reaction is supplied through inner heat exchange walls 106. The calciner 102 also has static mixer segments (shown in Figure 2) which assist the heat transfer and to promote uniform calcination, and conical separator segments (shown in Figure 3) to assist in the separation of the carbon dioxide from the granules in each segment. The residence time is set by the fall of the granular flow through the length, and is about 1.5 s. The flow of heat to maintain the calcination process is primarily supplied through the calciner walls 106. In this embodiment, the calciner walls 106 are heated at a heat exchange unit 108 by a heat exchange fluid, which may be compressed carbon dioxide, supplied from the power plant 140. The heat transfer to the granules falling through the calciner 102 is limited by the transport of heat through the calciner walls 106, as the heat transfer from the wall 106 to the granules is faster by virtue of the viscosity of the granular flow. The temperature in the calciner retort 104 experienced by the particles varies along the length of the retort 104, as determined principally by the balance of the heat transfer rate through the walls and the reaction rate. The temperature inside the calciner retort 104

will increase down the calciner as the conversion takes place and will approach that of the heat exchange fluid. The reaction rate is quenched by the background carbon dioxide and this effect is reduced by the conical separators (Figure 3), and the pumping of the gas from the calciner to produce a partial vacuum. The sorbent feed rate is controlled such that the sorbed CO_2 in the injected granules (to $\alpha^* = 30\text{-}50\%$) is released in a single pass. With a diameter of about 0.3 m, the sorbent capacity of the calciner retort 104 is about $1\text{-}3 \text{ kg s}^{-1}$ releasing about 0.5 kg s^{-1} of CO_2 . The CO_2 produced by the calciner 102 is drawn out of the calciner 102 by a gas extraction unit comprising a vacuum pump 116 and a compressor 118 in the example shown in Figure 1, which maintains the gas pressure in the calciner at not more than about 0.3 atm in the described example. The gas is passed through the power plant 146 to recuperate heat. The compressed CO_2 is available for sequestration, which is a process common to most carbon capture systems. The pressure is uniform within the calciner 102 of the described example. The carbon dioxide is extracted through the central tube of the gas/particles separators, as will be described below in Figure 3. The volume of the calciner 102 is about 1 m^3 . The volume could be reduced by decreasing the tube 104 diameter, with the constraint being that the heat transfer rate should be sufficient to achieve the required degree of calcination. The regenerated granules extracted from the base 122 of the calciner 102 are injected at the position 126 into a carbonator reactor 124. The carbonator reactor 124 is preferably based on an autothermal design. The flue gases from the power plant 142, after conditioning described in detail with reference to Figure 4 below, are injected near the base 136 of the carbonator and pass through the falling fluidised bed of granules. The temperature of the carbonator is a balance of the heat released by the carbonation reaction and the heat in the granules and gasses entering and leaving the reactor. In the autothermal mode, the temperature is that at which the carbonation is complete. The flue gas 126 is heated and the granules injected at 126 are cooled. The carbonator walls 127 in this embodiment are insulating. For energy efficiency, the calciner/carbonator reactor system is preferably incorporated into the thermal cycle of the power plant, such that the hot scrubbed flue gas 134 are routed to the power plant 144 for conditioning, as will be described with reference to Figure 4 below. It will be appreciated that there are many possible configurations which can depend not only on the thermal cycle but also on the choice of sorbent (calcium or magnesium or other). The carbonated granules are collected from the base 136 of the

carbonator 124 and are transported pneumatically in a riser 138 to the entrance 112 of the calciner 102 to complete the cycle.

5 It will be recognised that the described example specifies the source of heat for the calciner 102 as coming from within the power plant 140, and the heat in the flue gases also comes from power plant 142. This heat is recuperated, as much as is possible, from the carbon dioxide at power plant 146 and the scrubbed flue gas at power plant 144. This annotation represents that the reactor system as a whole is integrated into a power plant or other industrial process so as to maximise the thermal efficiency of the overall process. The source of the heat may be provided as part of the power plant combustion system, or from steam from that plant, or by a separate energy source.

10 In another embodiment, superheated steam can be used in the system as the means for pneumatically transporting the particles in the riser 138. The superheated steam will saturate the granules during this process, when they are injected into the calciner, it will catalyse to a limited degree the calcination reaction. A further advantage of using steam to transport and saturate the granules is that the released steam in the calciner gas stream is easily separated by a condenser before the gas is compressed, leading to pure carbon dioxide product. The condensation assists in pumping out of the gases for reasons discussed below. The use of superheated steam in this way reduces the complexity of the pneumatic systems. However, it will be appreciated that steam and carbon dioxide at high temperature are understood to catalyse the sintering of the granules, and therefore steam is preferably used sparingly in the calciner 102.

15 Returning to the description of the calciner reactor 102, it is important to recognise that the efficiency of the calciner relies on the heat transfer efficiency across the calciner walls and the suppression of the back reaction with carbon dioxide. To achieve a high efficiency, the calciner embodiments described include a helical static mixer (Figure 2) and conical gas separator (Figure 3) inserts.

20 Details of the static mixer in the example embodiment will now be described, with reference to Figure 2. The static mixer 200 is used, in part, to increase the surface area for heat transfer, but the principle tasks of the static mixer 200 are to deflect kinetic energy into the (r,θ) plane to induce the granular flow, and to mix the granule flow streams to break up the tendency for the granules to form a laminar flow, so that the degree of calcination is uniform across the calciner by virtue of this mixing. It is understood that the static mixer 200 can, for example, be constructed from helical

segments to achieve those tasks. In Figure 2, the static mixer 200 provides uniform turbulent mixing of the particles and the steam, and maximises the interactions of the particles with the calciner walls 104. The static mixer 200 is fabricated from plate segments 206 having a width equal to the inner diameter of the calciner walls 104 (Figure 1). The plate segments 206 are twisted at a pitch angle of about 33.3°, and having a segment length equal to the pitch, or one half of the pitch. Each segment is attached to a segment of the opposite handedness, rotated by 90°. The assembly of such segments is inserted into the calciner 102, and may be welded to it so that the surface area of the flange acts as a part of the heat exchanger system, or alternatively, joined in such a manner as to allow the segment to be vibrated so as to dislodge granules that would otherwise build up and constrict the particle flow. In the described embodiment, the assembly of the segments, i.e. the static mixer and the conical separator (Figure 3) extends from the base of the calciner 102 to substantially underneath the throat 112 (Figure 1). The central tube 204 is used to accommodate the gas flow from the conical separator in a tube 308 (Figure 3) positioned below this static mixer as shown in Figure 1.

Details of the conical solid-gas separator in the example embodiment will now be described, with reference to Figure 3. In this embodiment, conical gas-solids separators are deployed along the retort. Each conical segment e.g. 302 is placed so that granules falling onto the exterior of the cone 304 are deflected to the calciner walls 306, and the solids density is increased as the particles flow down towards the base of the cone 304. The gases from the segment 306 below are exhausted by their upwards flow into the inner region of the segment 304 and are injected into the upper part of the next upper segment through a tube 308 that passes through the static mixer central tube 204 (Figure 2). Breaking up of the granular flow, and the formation of dust in the conical separator is to be minimised. To prevent this dust from exiting the calciner, a screen 309 can be placed near the exhaust point of the gas and is electrically charged from an external battery so as to repel such disengaged granules, based on the fact that ground granules have a significant surface charge. That is, the separator 300 is designed to minimise granule entrainment in the exhaust. The separator can also be vibrated or rotated (vibrator unit or rotator unit 314) so as to eliminate the build-up of granules on surfaces. This separator structure 300 may be combined with a helical static mixer (compare Figure 2) by alternating respective segments, so that the helical static mixer causes azimuthal and radial mixing of the granules (to achieve uniform conversion),

while the cone section promotes efficient interaction with the calciner walls. Alternatively, the helical static mixer may be incorporated onto the outside of the conical structure 300. In a further embodiment, the background pressure of the carbon dioxide is reduced by partial evacuation of the calciner. It is noted that cooling of the exhausted gases as a stage of a gas compressor system will act as a pump. Steam may be injected in the conical separator 300 through a feed pipe 311 via pipe conduits 312 to a slotted ring 313 to provide not only a catalytic effect but also to flush the calciner to reduce the back reaction.

The reactor system 101 uses a very rapid calcination reaction. This preferably overcomes a number of practical hurdles to the use of the calciner/carboniser reaction for carbon capture. Firstly, the amount of time that the granules spend at high temperature has been minimised, and thus the effect of sintering is minimised. Sintering is cumulative, and at ~1.5 seconds per pass, the cumulative effect is equivalent to 1.5 minutes of sintering if the rate of feeding and bleeding gives an average of 60-100 passes. It is expected that the surface of the granules will degrade during the multiple passes as has been demonstrated by others, but these studies demonstrate that the particles will not lose their reactivity with 1.5 minutes of sintering. The degradation of the sorbent is more likely to arise from poisoning of the surface by SO_x in the flue gas.

The designs of the calciner and carbonator have a significant difference in that the calciner is reliant on heat transfer between the calciner wall 106 and the granules based on good conduction across this wall 106, whereas the walls 127 of the carbonator are insulating and the heat transfer is between the flue gases and the granules.

The calciner system described in Figure 1 has a residence time for the granules of ~1.5 seconds for a typical system, the injection rate of granules with a degree of carbonation $\alpha^i=30-50\%$ is 1-3 kg s⁻¹. At such rates, the heat transfer across the surface of the calciner in steady state is given by

$$UA(T_e - T_c) = \gamma \alpha^i \Delta H_{calc}(T_c)$$

where γ is feedstock injection rate in kg s⁻¹, A is the surface area of the calciner and ΔH_{calc} is the enthalpy of the reaction in J kg⁻¹, and U is the heat transfer coefficient in Wm⁻²K⁻¹ from the external heat exchanger at its (average) temperature T_e to the Feedstock particles at the (average) calcination temperature T_c , through the calciner surface. U is given by the expression

$$U = 1/(1/h_o + \delta r/k + 1/h_i)$$

where h_o is the heat transfer coefficient from hot flue gas 108 to the outer calciner wall 106, δr is the wall 106 thickness and k is the heat conductivity of the wall 106 material, and h_i is the heat transfer coefficient from the inner surface of the wall 106 to the particles. The calciner heat exchange system is designed such that $h_o \gg k/\delta r$. The viscosity of a granular flow is well approximated to be 1 Pa s, and this gives rise to a heat transfer coefficient $h_o \gg k/\delta r$, where h_o can be estimated from well established correlations of hydrodynamics. Thus, $U \sim k/\delta r$ in these embodiments. A reasonable temperature gradient can be established for the sorbent feed rates with a calciner diameter of ~0.3 m.

A single reactor system of the proposed design is capable of removing between ~0.5 kg s⁻¹ of carbon dioxide depending on the sorbent efficiency and the degree of sorption α^* for a temperature gradient of ~50°C across the calciner walls. Flue gasses are produced in large volumes by an industrial scale combustion process. For example, a 1000MW power plant consumes coal at 40 kg s⁻¹ and produces CO₂ at about 95 kg s⁻¹ with a total flue gas throughput of 440 kg s⁻¹. Using the reactor capacity described above, a farm of some 200 reactors can be implemented to scrub the CO₂, and this would be combined with one or more desulphonator reactors to scrub the SO_x prior to injection into the CO₂ reactor farm using the spent sorbent from these reactors. Each reactor system described above has a footprint of less than 1 m², excluding pneumatic transport systems and heat exchangers, is such that the array of calciner retorts occupies a footprint of not less than 200 m². Practical considerations of the provision of ancillary services increases this footprint considerably, but this minimal footprint is demonstrates an implementation viability of the described design. It is noted that the solids fraction of the calciner reactor ϵ_{calc} is very small, of order 5-15*10⁻⁴. This is a small solids fraction for a reactor, and distinguishes the embodiment from other fluid bed reactors. It is sufficiently large, however, that the collective flow is established, and that flow creates the necessary viscosity and heat transfer. The ϵ_{calc} is small because of the limited surface area of the calciner determines the rate of heat transfer to the granules, and that heat transfer is restricted by the heat flow across the calciner walls. Too high a flow and the calcination yield will fall.

Turning now to the carbonator reactor 124, the reaction time for the carbonation τ_{carb} is related to the reaction time of calcination τ_{calc} by the approximate expression

$$\tau_{\text{carb}} = \tau_{\text{calc}} \exp[\Delta H_{\text{calc}}(1/RT_{\text{carb}} - 1/RT_{\text{calc}})] / p_{\text{CO}_2, \text{carb}}$$

5 where $p_{\text{CO}_2, \text{carb}}$ is the partial pressure of CO₂ in the flue gases. For a typical system with $\tau_{\text{calc}} \sim 1.5$ s, $\tau_{\text{carb}} \sim 90$ s. This difference has important implications in the design of the reactor in example embodiments, because the volume of granules in the carbonator reactor V_{carb} is approximately related to that of the calciner V_{calc} by

$$10 \quad V_{\text{carb}} = N_{\text{calc}} V_{\text{calc}} \tau_{\text{carb}} / \tau_{\text{calc}} \epsilon_{\text{calc}} / \epsilon_{\text{carb}}$$

where N_{calc} is the number of calciner reactors that discharge into the carbonator reactor and ϵ_{carb} is the solids fill factor of the carbonator. In the embodiment described in Figure 1, $N_{\text{calc}}=1$. It is apparent that V_{carb} can be reduced by using a carbonator design in which the solids fill factor ϵ_{carb} is high, say ~ 0.1 . This is more typical of fluid bed reactors. In the limit of $N_{\text{calc}}=1$, a carbonator reactor retort with the same diameter as the calciner, namely 0.3m, the height of the carbonator reactor would be ~ 4 m, giving a total height of the calciner/carbonator reactor of ~ 16 m, excluding the ancillary equipment. This embodiment shows that the larger volume for the carbonator reactor can be compensated for by the higher solids fraction, and in the example described above, it can have a smaller volume. In contrast to the calciner design, the heat transfer in the autothermal carbonator is between the granules and the gas, and this gives the freedom to minimise the volume by increasing the solids fraction. The calciner solids fraction ϵ_{calc} is constrained by the heat transfer across the calciner walls. The freedom to scale the carbonator allows the development of a flue gas treatment system in which $N_{\text{calc}} \gg 1$ to simplify the flue gas handling processes. Thus the granules from N_{calc} calciners are fed into a carbonator and are recovered through N_{calc} ports that feed the granules into the respective calciners. The design of the carbonator reactor takes account of the granule size and the entrainment of granules in the flue gas stream must be minimised. This technology is understood and not the subject of this invention.

30 Further, for a given carbon capture system, there may be N_{carb} such carbonator reactors and N_{desulf} desulphonator reactors that consume the spent granules from the carbonator reactors. The design of desulphonator reactors is understood and is not the subject of this invention.

The schematic layout of a system that captures CO₂ and SO_x is set out in Figure 4 in an example embodiment. The flue gas 401 from a power station 402 is distributed in the desulphonator array 403 of N_{dsf} desulphonator reactors to extract the SO_x and the fly ash such that sulphonated granules and fly ash, indicated at numeral 404, are produced as a useful waste by product, as is conventionally done in flue gas desulphurisation. The SO_x and particulate scrubbed flue gas 405 is then injected into the carbonator array 406 of N_{cb} carbonator reactors. In these reactors the CO₂ is scrubbed by the sorbent and the flue gas, now scrubbed of both CO₂ and SO_x has the dust from entrained granules removed 407, and is cooled by a heat exchanger 408 before being released to the atmosphere. The order of the processes of dust removal 407 and heat exchange 408 in different embodiments depends on the method of integration of this system into a power plant 402, and the schematic representation in Figure 4 should not be considered as a limitation.

The CO₂ loaded sorbent granules 410 are pneumatically transported to the calciner array 411. The N_{cb} calciner reactors of the array 411 calcine the sorbent to release a pure stream of carbon dioxide which is pumped 412 from the calciners and the dust 413 from entrained sorbent granules is collected. A condenser/heat exchanger 414 is used to condition the gas which is then compressed 415 and is ready for sequestration. The order of the processes of dust removal, pumping and heat exchange depends on the method of integration of this system into a power plant, and the flow chart of Figure 4 should not be considered as a limitation.

In the calciner array 411, the sorbent granules are regenerated by the aforesaid release of CO₂ and the regenerated sorbent granules 417 are then transported pneumatically to the carbonator array 406 to complete the process. Fresh sorbent granules produced from sorbent feedstock 418 in a sorbent fabrication plant 419 are introduced into the carbonator array 406. This is done at the same rate as the spent sorbent granules 420 are bled from the carbonator array and sulphonated granules are ejected 404 from the desulphonator array 403, so that the loading of the system by granules is maintained, taking into account the mass changes of granules in the respective processes and any particle deprecipitation.

With reference to Figure 4, it is noted that the routing of the gasses and granules is indicated only schematically. In one embodiment, the flue gas in the carbonator array 406 is routed through one or more of the carbonator reactors of the array 406 so as to achieve the optimum reduction of CO₂. When more than one carbonator reactors is so

used, it is preferable to inject the fresh granules into the last carboniser where the partial pressure of CO_2 in the flue gas is significantly reduced from that at injection into the array. In this embodiment, the routing of the gases through the carbonator reactors leads to a progressive reduction of CO_2 concentration, and the conditions for carbon capture in the last such reactor will be more stringent. In this case, there is a bleed of granules from this one carboniser to another such that, at the first carboniser that the flue gas passes through, the granules are bled into the desulphonator array 403. It will be appreciated that this utility of the described embodiment is dependent on the design of the carbonators, which is not the subject of the present application. However, this utility emphasises the flexibility of the modular approach in the described example embodiment.

With respect to desulphonation, in a practical system for capturing carbon from flue gases, any gases that permanently react with the sorbent should be removed or else the granules will be poisoned. The major component of flue gasses that has the capacity to poison the granules is sulphur dioxide/trioxide referred to as SO_x . For coal, this depends on the extent that the coal is washed to remove inorganic sulphides, and the organic content of the coal. While SO_x is removed effectively by washing with limestone, this is a low temperature solution process and is not integrated with the described example. The bleed 420 of granules from the reactor system as part of the method to refresh the granules in the calciner/carboniser reactor system produces a product that has significant residual activity for reaction with SO_x .

The granules can be injected into the flue gas in the desulphonators array 403 at high temperature, and will react with the SO_x , converting it to $\text{MSO}_3/\text{MSO}_4$. This is referred to as "furnace sorbent injection" and essentially replaces the SO_x by CO_2 . The MSO_3/SO_4 is in the form of MO granules in which the surface layer of about 30-50% is $\text{MSO}_3/\text{MSO}_4$ as a result of pore blocking discussed above for carbonation. This form of removing SO_x does not require the flue gases to be cooled for solution based scrubbing, and then reheated for carbon removal. The amount of sorbent feedstock (limestone, dolomite) used by a plant for furnace sorbent injection may not be too different from one that firstly produces the sorbent from that feedstock in a calciner in a sorbent fabrication plant 419, and then uses that sorbent in the calciner 411 and carbonator 406 arrays and then uses the spent granules for scrubbing SO_x in the sulphonator array 403. If the C:S ratio in the flue gasses is say, 3%, and each granule goes through 60 cycles of removing CO_2 , and the granules remove SO_x with an efficiency of 30%, then the

feedstock/sulphur ratio is 1:1, which is comparable to that for an efficient SO_x scrubber. The granules from this process would be removed from the flue gas, and such capture would also capture fly ash. The solids product can be used as a filler for construction materials.

5 To appreciate the scale of the system, it is understood that flue gasses are produced in large volumes by an industrial scale combustion process. For example, a 1000MW power plant consumes coal at 40 kg s^{-1} and produces CO_2 at about 95 kg s^{-1} with a total flue gas throughput of 440 kg s^{-1} . Using the reactor capacity described above, a farm of some $N_{\text{calc}} N_{\text{carb}} = 200$ calciner reactors can be implemented to scrub
10 the CO_2 , and this would be combined with a number of SO_x reactors to scrub the SO_x prior to injection into the CO_2 reactor farm. In the embodiment described in Figure 4, the flue gasses progress through the system in a fixed path. However, the flow of the flue gasses between, say, the N_{carb} carbonators can be reconfigured using valves that could isolate, say, any one module for repair and maintenance without substantially
15 decreasing the flue gas flow. The autonomous regulation of the system to changes would allow the farm to maintain operation during a change of flow, providing that the changes occur relatively slowly on the timescale of minutes to hours.

In another embodiment, the calciner/carbonator reactor system described above with $N_{\text{calc}} = 1$ can be miniaturised for use with small combustors, as the energy
20 requirements are small, the system can regulate itself, and feedstock for fabricating the sorbents is plentiful, and the scrubbed material can be recycled with the compressed carbon dioxide.

Figure 5 shows a flow chart 500 illustrating a method for calcination/carbonation cycle processing. At step 502, partially carbonated mineral
25 sorbent granules are received in a calciner reactor. At step 504, heat is transferred through a wall of the calciner reactor to a granular flow of the sorbent granules for facilitating a calcination reaction of the sorbent granules to regenerate the sorbent granules. At step 506, gas products are removed from the calciner, wherein the gas products comprise carbon dioxide from the calcination reaction. At step 508, the
30 regenerated sorbent granules from the calciner reactor and a cold flue gas are received in a carbonator reactor, such that the regenerated sorbent granules are partially carbonised while the flue gas is scrubbed and the partially carbonated sorbent granules and the scrubbed flue gas exit the carbonator reactor as respective

hot materials. At step 510, the partially carbonated sorbent granules from the carbonator reactor are cycled to the calciner reactor.

5 It will be appreciated by a person skilled in the art that numerous variations and/or modifications may be made to the present invention as shown in the specific embodiments without departing from the spirit or scope of the invention as broadly described. The present embodiments are, therefore, to be considered in all respects to be illustrative and not restrictive.

The claims defining the invention are as follows:

1. A system for calcination/carbonation cycle processing, the system comprising:
- a calciner reactor for receiving partially carbonated mineral sorbent granules, the calciner reactor arranged such that the sorbent granules move through the calciner reactor under gravitational forces in a granular flow;
 - a heat exchange structure for transferring heat through a wall of the calciner reactor to the granular flow of the sorbent granules for facilitating a calcination reaction of the sorbent granules to regenerate the sorbent granules;
 - a gas extraction unit for removing gas products from the calciner, wherein the gas products comprise carbon dioxide from the calcination reaction;
 - a carbonator reactor for receiving the regenerated sorbent granules from the calciner reactor and for receiving a cold flue gas, such that the regenerated sorbent granules are partially carbonised while the flue gas is scrubbed and the partially carbonated sorbent granules and the scrubbed flue gas exit the carbonator reactor as respective hot materials; and
 - a riser unit for cycling the partially carbonated sorbent granules from the carbonator reactor to the calciner reactor.
2. The system as claimed in claim 1, wherein the calciner reactor comprises:
- a feeder unit for the granules;
 - a retort chamber having the feeder unit located at a top portion thereof, whereby the sorbent granules move through the retort chamber under gravitational forces in a granular flow; and
 - the heat exchange structure is thermally coupled to a wall of the retort chamber for providing heat to the granules inside the retort chamber through heat transfer through the wall of the retort chamber.
3. The system as claimed in claim 2, wherein the riser unit pneumatically cycles the partially carbonated sorbent granules from a base of the carbonator reactor to the feeder unit at the top of the retort chamber.

4. The system as claimed in claims 2 or 3, further comprising a mixer means disposed inside the retort chamber, the mixer means imparting at least horizontal forces on the granules moving through the chamber such that the granules are moved towards the wall of the retort chamber for facilitating the heat exchange to the granules through the wall of the retort chamber.

5. The system as claimed in any one of the preceding claims, wherein the gas extraction unit comprises a gas/particles separator structure disposed inside the calcination reactor and coupled to exhaust openings of the retort chamber for facilitating separation of the gas products from the granules.

6. The system as claimed in any one of the preceding claims, wherein the gas extraction unit comprises a vacuum pump for removing the gas products from the calciner reactor.

7. The system as claimed in any one of the preceding claims, wherein a gas used to pneumatically cycle the granules from the carbonator to the calciner is steam.

8. The system as claimed in any one of the preceding claims, wherein the calciner reactor comprises a plurality of retort chambers, each retort chamber comprising a feeder unit located at a top portion of said each retort chamber, whereby the granules move through said each retort chamber under gravitational forces in a granular flow; the heat exchange structure is thermally coupled to a wall of said each retort chamber for providing heat to the sorbent granules inside said each retort chamber through heat transfer through the wall of said each retort chamber; and the gas extraction unit removes the gas products from said each retort chamber.

9. The system as claimed in any one of the preceding claims, comprising a plurality of carbonator reactors, wherein the regenerated sorbent granules are fed serially through the plurality of carbonator reactors.

10. The system as claimed in any one of the preceding claims, further comprises a bleed unit for bleeding a portion of the calcinated granules from the calciner reactor prior to the carbonator reactor, and a feed unit for feeding a corresponding portion of fresh calcinated granules into the carbonator reactor.

5 11. The system as claimed in any one of the preceding claims, wherein the sorbent granules have a size distribution between about 40 microns to about 125 microns.

10 12. The system as claimed in any one of the preceding claims, further comprising means for scrubbing dust from the gas products comprising the carbon dioxide.

13. The system as claimed in any one of the preceding claims, further comprising means for cooling the gas products comprising the carbon dioxide.

15 14. The system as claimed in any one of the preceding claims, further comprising means for compressing the gas products comprising the carbon dioxide.

15. A method for calcination/carbonation cycle processing, the method comprising the steps of:

20 receiving partially carbonated mineral sorbent granules in a calciner reactor;
providing for movement of the sorbent granules through the calciner reactor under gravitational forces in a granular flow;

transferring heat through a wall of the calciner reactor to the granular flow of the sorbent granules for facilitating a calcination reaction of the sorbent granules to regenerate
25 the sorbent granules;

removing gas products from the calciner, wherein the gas products comprise carbon dioxide from the calcination reaction;

30 receiving the regenerated sorbent granules from the calciner reactor and a cold flue gas in a carbonator reactor, such that the regenerated sorbent granules are partially carbonised while the flue gas is scrubbed and the partially carbonated sorbent granules and the scrubbed flue gas exit the carbonator reactor as respective hot materials; and

cycling the partially carbonated sorbent granules from the carbonator reactor to the calciner reactor.

16. The method as claimed in claim 15, wherein the calciner reactor
5 comprises:

a feeder unit for the granules;

a retort chamber having the feeder unit located at a top portion thereof, whereby the
sorbent granules move through the retort chamber under gravitational forces in a granular
flow; and

10 the heat exchange structure is thermally coupled to a wall of the retort chamber for
providing heat to the granules inside the retort chamber through heat transfer through the
wall of the retort chamber.

17. The method as claimed in claim 16, wherein the partially carbonated
15 sorbent granules is pneumatically cycles from a base of the carbonator reactor to the feeder
unit at the top of the retort chamber.

18. The method as claimed in claims 16 or 17, further comprising imparting at
least horizontal forces on the granules moving through the chamber such that the granules are
20 moved towards the wall of the retort chamber for facilitating the heat exchange to the
granules through the wall of the retort chamber.

19. The method as claimed in any one of claims 15 to 18, comprising utilising
a gas/particles separator structure disposed inside the calcination reactor and coupled to
25 exhaust openings of the retort chamber for facilitating separation of the gas products from the
granules.

20. The method as claimed in any one of claims 15 to 19, comprising utilising
a vacuum pump for removing the gas products from the calciner reactor.

30

21. The method as claimed in any one of claims 15 to 20, wherein a gas used
to pneumatically cycle the granules from the carbonator to the calciner is steam.

22. The method as claimed in any one of claims, 15 to 21 wherein the calciner reactor comprises a plurality of retort chambers, each retort chamber comprising a feeder unit located at a top portion of said each retort chamber, whereby the granules move through said each retort chamber under gravitational forces in a granular flow; the heat exchange structure is thermally coupled to a wall of said each retort chamber for providing heat to the sorbent granules inside said each retort chamber through heat transfer through the wall of said each retort chamber; and the gas extraction unit removes the gas products from said each retort chamber.

23. The method as claimed in any one of claims 15 to 22, comprising utilising a plurality of carbonator reactors, wherein the regenerated sorbent granules are fed serially through the plurality of carbonator reactors.

24. The method as claimed in any one of claims 15 to 23, further comprising bleeding a portion of the calcinated granules from the calciner reactor prior to the carbonator reactor, and feeding a corresponding portion of fresh calcinated granules into the carbonator reactor.

25. The method as claimed in any one of claims 15 to 24, wherein the sorbent granules have a size distribution between about 40 microns to about 125 microns.

26. The method as claimed in any one of claims 15 to 25, further comprising scrubbing dust from the gas products comprising the carbon dioxide.

27. The method as claimed in any one of claims 15 to 26, further comprising cooling the gas products comprising the carbon dioxide.

28. The method as claimed in any one of claims 15 to 27, further comprising compressing the gas products comprising the carbon dioxide.

DATED this 23rd Day of November 2010

CALIX LTD

Patent Attorneys for the Applicant

SPRUSON&FERGUSON

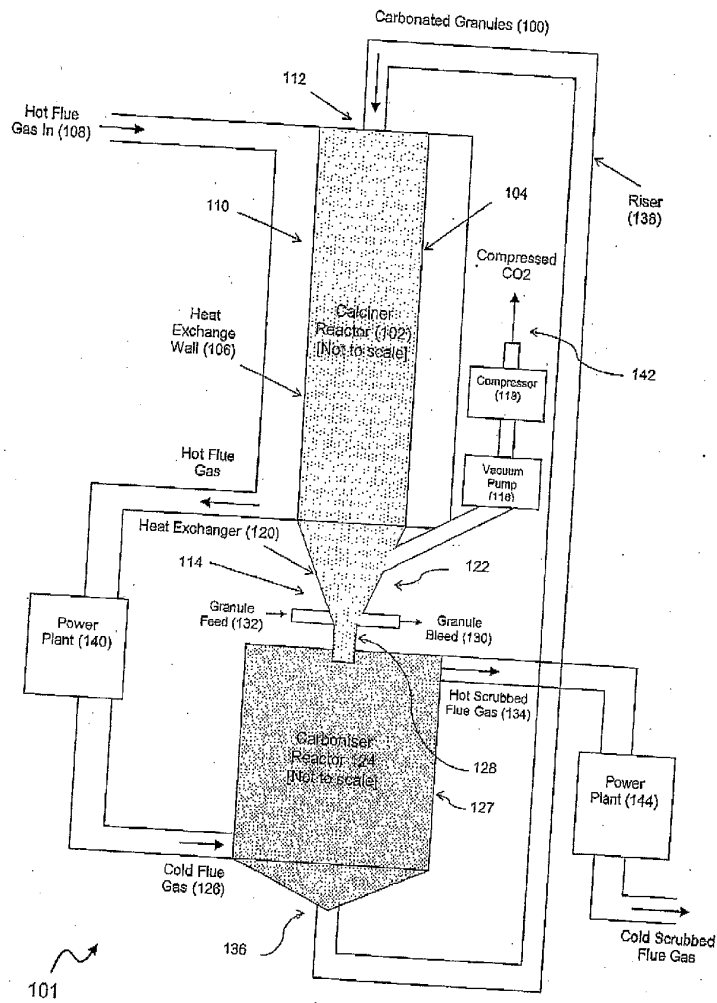

Figure 1

Amended Sheet
IPEA/AU

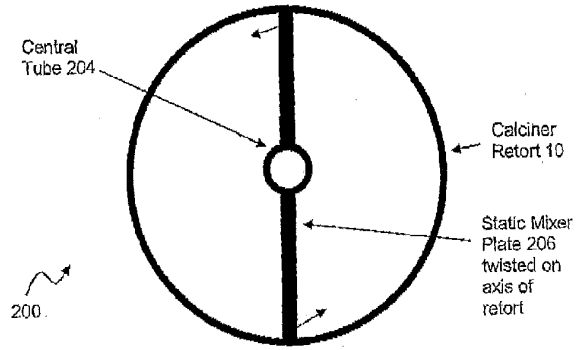

Figure 2

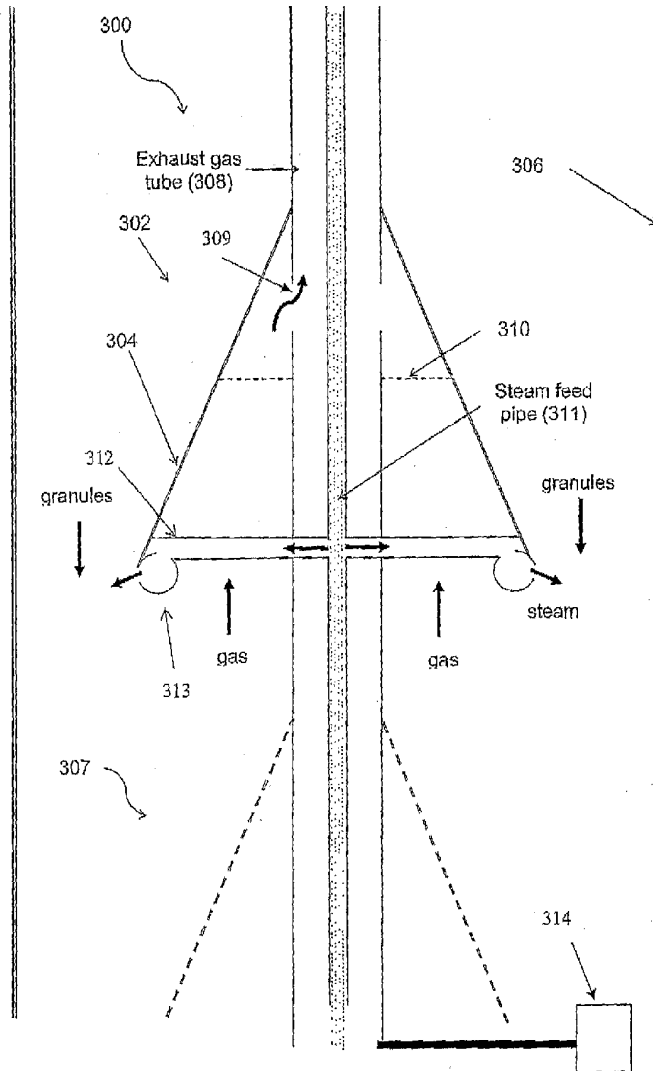

Figure 3

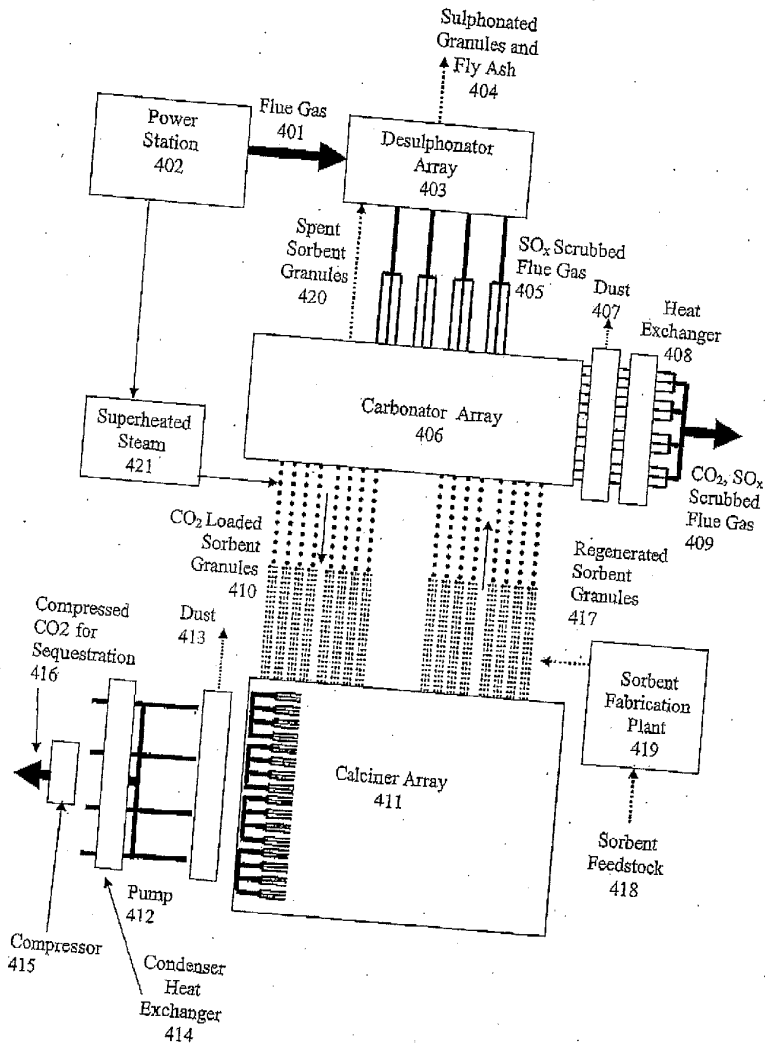

Figure 4

Amended Sheet
IPEA/AU

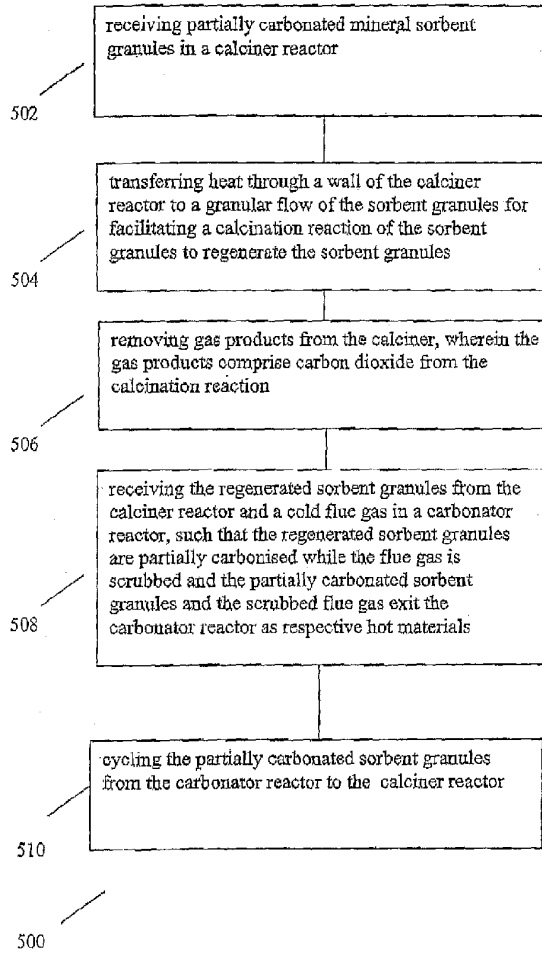

Figure 5