

(12) PATENT
(19) AUSTRALIAN PATENT OFFICE

(11) Application No. AU 199955462 B2
(10) Patent No. 744022

(54) Title
Multiple flavor beverage dispensing air-mix nozzle

(51)⁷ International Patent Classification(s)
B67D 005/56

(21) Application No: **199955462**

(22) Application Date: **1999.08.02**

(87) WIPO No: **WO00/07928**

(30) Priority Data

(31) Number	(32) Date	(33) Country
09/128241	1998.08.03	US
09/216527	1998.12.18	US

(43) Publication Date : **2000.02.28**

(43) Publication Journal Date : **2000.05.04**

(44) Accepted Journal Date : **2002.02.14**

(71) Applicant(s)
Lancer Partnership, Ltd.

(72) Inventor(s)
Alfred A. Schroeder; Darren W. Simmons; John D. Santy Jr.

(74) Agent/Attorney
PHILLIPS ORMONDE and FITZPATRICK,367 Collins Street,MELBOURNE VIC 3000

(56) Related Art
US 5415326



25402147

INTERNATIONAL APPLICATION PUBLISHED UNDER THE PATENT COOPERATION TREATY (PCT)

(51) International Patent Classification ⁶ : B67D 5/56	A1	(11) International Publication Number: WO 00/07928 (43) International Publication Date: 17 February 2000 (17.02.00)
<p>(21) International Application Number: PCT/US99/17481</p> <p>(22) International Filing Date: 2 August 1999 (02.08.99)</p> <p>(30) Priority Data: 09/128,241 3 August 1998 (03.08.98) US 09/216,527 18 December 1998 (18.12.98) US</p> <p>(71) Applicant (for all designated States except US): LANCER PARTNERSHIP, LTD. [US/US]; 6655 Lancer Boulevard, San Antonio, TX 78219 (US).</p> <p>(72) Inventors; and (75) Inventors/Applicants (for US only): SCHROEDER, Alfred, A. [-/US]; 2811 Whisper Fawn, San Antonio, TX 78230 (US). SIMMONS, Darren, W. [-/US]; 26351 Romance Point, San Antonio, TX 78260 (US). SANTY, John, D., Jr. [-/US]; 4620 Thousand Oaks #910, San Antonio, TX 78233 (US).</p> <p>(74) Agents: MAKAY, Christopher, L. et al.; 1634 Milam Building, 115 East Travis Street, San Antonio, TX 78205 (US).</p>	<p>(81) Designated States: AL, AM, AU, AZ, BA, BB, BG, BR, BY, CA, CN, CU, CZ, EE, GE, HU, IL, IS, JP, KE, KG, KR, KZ, LC, LK, LR, LS, LT, LV, MD, MG, MK, MN, MW, MX, NZ, PL, RO, RU, SD, SG, SI, SK, TJ, TM, TR, TT, UA, UG, US, UZ, VN, European patent (AT, BE, CH, CY, DE, DK, ES, FI, FR, GB, GR, IE, IT, LU, MC, NL, PT, SE).</p> <p>Published With international search report. Before the expiration of the time limit for amending the claims and to be republished in the event of the receipt of amendments.</p>	

(54) Title: MULTIPLE FLAVOR BEVERAGE DISPENSING AIR-MIX NOZZLE

(57) Abstract

In a beverage dispensing nozzle (10), a cap member (11) includes first, second and third beverage syrup inlet ports (21-23) coupled to respective first, second, and third beverage syrup sources. The cap member further includes a mixing fluid inlet port (27) coupled to a mixing fluid source. An inner housing (16) including a chamber (40) is coupled to the cap member. A first annulus (17) disposed within the chamber of the inner housing defines a first annular beverage syrup channel (54) with the inner housing, wherein the first beverage syrup inlet port communicates beverage syrup to the first annular beverage syrup channel. A second annulus (18) disposed within the chamber of the inner housing defines a second annular beverage syrup channel (58) with the first annulus. A third annulus (19) disposed within the chamber of the inner housing defines a third annular beverage syrup channel (64) with the second annulus.

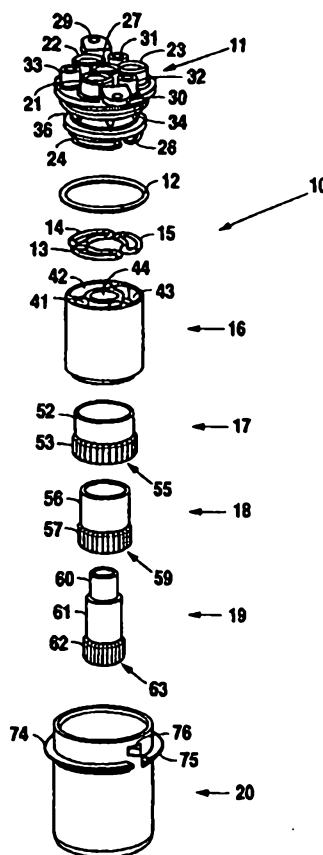

MULTIPLE FLAVOR BEVERAGE DISPENSING AIR-MIX NOZZLE

BACKGROUND OF THE INVENTION

1. Field of the Invention

The present invention relates to beverage dispensing nozzles and, more particularly, but not by way of limitation, to a beverage dispensing nozzle for dispensing multiple flavored drinks, including flavor additives, from a single nozzle without intermingling drink flavors.

2. Description of Related Art

Due to increases in both the number of customers served and the volume of drinks dispensed by the food and drink service industry and counter space being at a premium, standard drink dispensing nozzles fail to meet customer demand. In order to reduce space requirements, and also for aesthetic reasons, it is desirable to dispense multiple flavors of drinks, including flavor additives, from a single nozzle.

In dispensing drinks from a nozzle, it is essential that the flavored syrup, and, if desired, flavor additive, be intimately mixed with a mixing fluid, such as carbonated or plain water, so that the resulting drink is of uniform consistency. When the mixing fluid is carbonated water, it is essential that the carbonated water and syrup, and, if desired, flavor additive, be mixed in such a manner that the carbon dioxide does not excessively escape and produce undesirable foaming.

One major problem encountered with multiple flavor nozzles is syrup carryover. It is very difficult to completely remove the residual syrup from a previously dispensed drink to avoid carryover into a subsequent, different flavored drink. This carryover causes problems with the flavor, the color, and the smell of dispensed drinks. Even small amounts of carryover syrup which cause only minor problems with odor and taste have a significant effect on the color of clear drinks, which is undesirable.

Another problem that must be addressed is proper mixing of the mixing fluid, such as carbonated or plain water, and syrup, and, if desired, flavor additives. To insure proper mixing, it is necessary to expose the maximum surface area of the syrup, and, if desired, flavor additive, to the mixing fluid. If the mixing is to occur outside the nozzle, it is important that the momentum of the syrup stream, and, if desired, flavor additive stream, be substantially equal to or less than the momentum of the mixing fluid stream.

Excessive foaming is another problem when the mixing fluid is carbonated water.

To prevent excessive foaming, the carbonated water, which enters the nozzle at a high pressure, must be gently reduced to atmospheric pressure so that a minimum of carbon dioxide will escape solution. At high flow rates, out-gassing of carbon dioxide is particularly troublesome. Consequently, as the carbonated water releases carbon dioxide in both the nozzle and the cup, the released carbon dioxide escaping solution causes excessive foaming of the dispensed beverage. That excessive foaming creates a poor product because the drink is generally "flat".

Prior attempts to solve the aforementioned problems with multiple flavor nozzles have not been successful. In most instances, as in U.S. Patent 4,928,854, which issued on May 29, 1990, to McCann, the syrup is delivered to the nozzle exit through a separate tubular conduit for each flavor. The syrup flows through a plurality of separate conduits to a discharge opening into a water channel for delivery to the exit end of the nozzle. The total surface area of syrup presented for contact with the mixing fluid is relatively small; thus proper mixing is difficult. The configuration also makes it difficult to eliminate syrup carryover.

The above discussion of background art is included to explain the context of the present invention. It is not to be taken as an admission that any of the material referred to was published, known or part of the common general knowledge in Australia as at the priority date of any of the claims of this specification.

SUMMARY OF THE INVENTION

According to a first broad aspect, the present invention provides a beverage dispensing nozzle, comprising:

a cap member comprising a first beverage syrup inlet port coupled to a first beverage syrup source and a mixing fluid inlet port coupled to a mixing fluid source;

an inner housing coupled to the cap member, wherein the inner housing defines a chamber;

a first annulus disposed within the chamber of the inner housing, the first annulus and the inner housing defining a first beverage syrup channel, wherein the first beverage syrup inlet port communicates beverage syrup to the first beverage syrup channel for discharge from the beverage dispensing nozzle substantially undiluted with mixing fluid; and

an outer housing coupled to the cap member, the outer housing and the



inner housing defining a mixing fluid channel, wherein the mixing fluid inlet port communicates mixing fluid to the mixing fluid channel for discharge from the beverage dispensing nozzle for contact with exiting beverage syrup to mix therewith outside the beverage dispensing nozzle.

5 In at least one preferred form, the beverage dispensing nozzle is utilized with a counter top or similar beverage dispenser. Upon the activation of a standard dispensing valve, a mixing fluid, such as carbonated or plain water, is delivered to the discharge end of the beverage dispensing nozzle through an annular channel. Thus, the beverage dispensing nozzle discharges the mixing fluid in a circular path around its exit end. A
 10 selected beverage syrup is delivered to the discharge end of the beverage dispensing nozzle through a concentric annular channel. In the preferred embodiments, the annular channel may be partially closed at its discharge end to restrict the beverage syrup flow, thereby insuring adequate momentum to propel the beverage syrup from the beverage dispensing nozzle into intimate contact with the mixing fluid. Furthermore, if desired, a
 15 selected flavor additive is delivered to the discharge end of the beverage dispensing nozzle through a flavor additive conduit.

The mixing fluid is delivered to the exit end of the nozzle through an annular channel that is concentric to the beverage syrup annular channels. The mixing fluid surrounds an exiting beverage syrup stream and flavor additive stream and is directed
 20 inwardly for maximum surface contact with the beverage syrup and flavor additive. On its travel from the nozzle to a container in the preferred embodiments, the mixing fluid travels at substantially equal or higher momentum than the beverage syrup and flavor additive to insure proper mixing. In a second embodiment, a second stream of mixing fluid exits through a center conduit in the beverage dispensing nozzle. This is
 25 particularly the case for single flavor nozzles and for large volume nozzles.

A most significant feature of the invention is the distribution of beverage syrup in a circumferential pattern around the exit end of the beverage dispensing nozzle, thus presenting the greatest surface area for contact with the mixing fluid. In the preferred
 30 embodiments, the momentum of the syrup as it exists the nozzle is controlled so that it is substantially equal to or less than the momentum of the mixing fluid to insure intimate mixing, while avoiding carbon dioxide breakout when the mixing fluid is carbonated water.

In a preferred embodiment, the beverage dispensing nozzle, includes a first annulus, a second annulus, and a third annulus that form three annular beverage syrup



channels along with an inner housing. Furthermore, the third or innermost annulus includes a flavor additive conduit therethrough to permit the inclusion of a flavor additive in the dispensed drink.

5 According to a second broad aspect, the present invention provides a method of forming a beverage drink utilizing a beverage dispensing nozzle, comprising the steps of:

delivering a beverage syrup to a first beverage syrup inlet port of a cap member;
delivering a mixing fluid to a mixing fluid inlet port of the cap member;

10 delivering the beverage syrup from the first beverage syrup inlet port to a first channel defined by an inner housing coupled with the cap member and a first annulus disposed in the inner housing;

discharging the beverage syrup from the first annular beverage syrup channel substantially undiluted with mixing fluid;

15 delivering the mixing fluid from the mixing fluid inlet port to a mixing fluid channel defined by an outer housing coupled to the cap member and the inner housing;
and

discharging the mixing fluid from the mixing fluid channel for contact with exiting beverage syrup to mix therewith outside the beverage dispensing nozzle.

20 In its various embodiments, the present invention is therefore able to provide a beverage dispensing nozzle that:

- dispenses a beverage syrup and mixing fluid at a high volume flow to form a dispensed beverage drink;

- eliminates stratification between the beverage syrup and mixing fluid;

25 - is capable of dispensing multiple flavors while preventing carryover between different flavoured syrups; and/or

- has a flavor additive conduit therethrough to permit the inclusion of a flavor additive in the dispensed drink.

30 The above and other features and advantages of the present invention will become evident to those skilled in the art from the following detailed description of preferred embodiments of the invention with reference to the accompanying drawings.



Throughout the description and claims of this specification the word “comprise” and variations of that word such as “comprises” and “comprising” are not intended to exclude other additives, components, integers or steps.

5 BRIEF DESCRIPTION OF THE DRAWINGS

FIG. 1 is perspective view illustrating a multiple flavor beverage dispensing air-

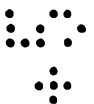
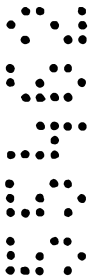

mix nozzle according to a first embodiment.

FIG. 2 is perspective view illustrating the multiple flavor beverage dispensing air-mix nozzle according to the first embodiment.

FIG. 3 is a front elevation view illustrating the multiple flavor beverage dispensing air-mix nozzle according to the first embodiment.

FIG. 4 is a top plan view illustrating the multiple flavor beverage dispensing air-mix nozzle according to the first preferred embodiment.

FIG. 5 is a cross-sectional view taken along lines 5,5 of Fig. 3 illustrating the multiple flavor beverage dispensing air-mix nozzle according to the first preferred embodiment.

FIG. 6 is a bottom plan view illustrating the multiple flavor beverage dispensing air-mix nozzle according to the first preferred embodiment.

FIG. 7 is a cross-sectional view taken along lines 7,7 of Fig. 4 illustrating the multiple flavor beverage dispensing air-mix nozzle according to the first preferred embodiment.

FIG. 8 is a cross-sectional view taken along lines 8,8 of Fig. 4 illustrating the multiple flavor beverage dispensing air-mix nozzle according to the first preferred embodiment.

FIG. 9 is a cross-sectional view taken along lines 9,9 of Fig. 4 illustrating the multiple flavor beverage dispensing air-mix nozzle according to the first preferred embodiment.

FIG. 10 is a cross-sectional view taken along lines 7,7 of Fig. 4 illustrating a multiple flavor beverage dispensing air-mix nozzle according to a second embodiment.

FIG. 11 is a cross-sectional view taken along lines 8,8 of Fig. 4 illustrating the multiple flavor beverage dispensing air-mix nozzle according to the second embodiment.

FIG. 12 is a cross-sectional view taken along lines 9,9 of Fig. 4 illustrating the multiple flavor beverage dispensing air-mix nozzle according to the second embodiment.

FIG. 13 is a cross-sectional view illustrating a multiple flavor beverage dispensing air-mix nozzle according to a third embodiment.

FIG. 14 is a cross-sectional view illustrating a multiple flavor beverage dispensing air-mix nozzle according to a fourth embodiment.

FIG. 15 is a cross-sectional view illustrating a multiple flavor beverage

dispensing air-mix nozzle according to a fifth embodiment.

FIG. 16 is a cross-sectional view illustrating a multiple flavor beverage dispensing air-mix nozzle according to a sixth embodiment.

FIG. 17 is a cross-sectional view illustrating a multiple flavor beverage dispensing air-mix nozzle according to a seventh embodiment.

FIG. 18 is a cross-sectional view illustrating a multiple flavor beverage dispensing air-mix nozzle according to an eighth embodiment.

FIG. 19 is a cross-sectional view illustrating a multiple flavor beverage dispensing air-mix nozzle according to a ninth embodiment.

FIG. 20 is a cross-sectional view illustrating a multiple flavor beverage dispensing air-mix nozzle according to a tenth embodiment.

DETAILED DESCRIPTION OF THE PREFERRED EMBODIMENT

As illustrated in Figs. 1-9, a beverage dispensing nozzle 10 includes a cap member 11, an o-ring 12, gaskets 13-15, an inner housing 16, a first or outer annulus 17, a second or intermediate annulus 18, a third or inner annulus 19, and an outer housing 20. The inner housing 16 defines a chamber 40 and includes an opening 44 into chamber 40. The inner housing 16 includes cavities 41-44 that communicate with the chamber 40 through conduits 45-47, respectively (refer to Figs. 1 and 2). Even though the conduits 45-47 connect to separate cavities 41-43, they are concentrically spaced apart; namely, the conduit 47 is innermost, the conduit 45 is intermediate, and the conduit 46 is outermost (refer to Figs. 7-9). The conduits 45-47 are concentrically spaced apart so that beverage syrup may enter the chamber 40 at three separate points. The interior wall of the inner housing 16 defining the chamber 40 includes stair-steps 48-51.

The first or outer annulus 17 includes an upper member 52 and a discharge member 53 (refer to Figs. 1 and 2). The first or outer annulus 17 fits within the chamber 40 of the inner housing 16 such that a portion of the upper member 52 engages the stair step 49. That portion of the upper member 52 may press fit with the stair step 49 or, as in this first embodiment, an adhesive may be used to secure that portion of the upper member 52 with the stair step 49. The first or outer annulus 17 and the interior wall of the inner housing 16 defining the stair step 48 form an annular channel 54 that connects with the conduit 46 of the inner housing 16. The annular channel 54 insures a large volume of beverage syrup flows uniformly about the first or outer annulus 17 during

discharge (refer to Figs 7-9). The discharge member 53 includes discharge channels 55 to aid the annular channel 54 in discharging the beverage syrup because the discharge member 53 is sized to substantially reside within the lower portion of the interior wall for the inner housing 16 (refer to Fig. 6). The discharge member 53 operates to discharge the beverage syrup in a restricted annular flow to insure uniform distribution of the beverage syrup as it exits from the beverage dispensing nozzle 10, thereby providing a maximum surface area for contact with mixing fluid also exiting from the beverage dispensing nozzle 10.

The second or intermediate annulus 18 includes an upper member 56 and a discharge member 57 (refer to Figs. 1 and 2). The second or intermediate annulus 18 fits within the first or outer annulus 17 such that a portion of the upper member 56 engages the stair step 50. That portion of the upper member 56 may press fit with the stair step 50 or, as in this first embodiment, an adhesive may be used to secure that portion of the upper member 56 with the stair step 50. The second or intermediate annulus 17 and the interior wall of the first or outer annulus 17 form an annular channel 58 that connects with the conduit 45 of the inner housing 16. The annular channel 58 insures a large volume of beverage syrup flows uniformly about the second or intermediate annulus 18 during discharge (refer to Figs 7-9). The discharge member 57 includes discharge channels 59 to aid the annular channel 58 in discharging the beverage syrup because the discharge member 57 is sized to substantially reside within the lower portion of the interior wall for the first or interior annulus 17. The discharge member 57 operates to discharge the beverage syrup in a restricted annular flow to insure uniform distribution of the beverage syrup as it exits from the beverage dispensing nozzle 10, thereby providing a maximum surface area for contact with mixing fluid also exiting from the beverage dispensing nozzle 10.

The third or inner annulus 19 includes a securing member 60, an intermediate member 61 and a discharge member 62 (refer to Figs. 1 and 2). The third or inner annulus 19 fits within the second or intermediate annulus 18 such that the securing member 60 protrudes through the opening 44 of the inner housing and engages the interior wall of the inner housing 16 defining the opening 44. The securing member 60 may press fit with the interior wall of the inner housing 16 defining the opening 44 or, as in this first embodiment, an adhesive may be used to secure the securing member 60 with

the interior wall of the inner housing 16 defining the opening 44. The third or inner annulus 19 and the stair step 51 and the interior wall of the second or intermediate annulus 18 form an annular channel 64 that connects with the conduit 47 of the inner housing 16. The annular channel 64 insures a large volume of beverage syrup flows uniformly about the third or interior annulus 19 during discharge (refer to Figs 7-9). The discharge member 62 includes discharge channels 63 to aid the annular channel 64 in discharging the beverage syrup because the discharge member 62 is sized to substantially reside within the lower portion of the interior wall for the second or intermediate annulus 18. The discharge member 62 operates to discharge the beverage syrup in a restricted annular flow to insure uniform distribution of the beverage syrup as it exits from the beverage dispensing nozzle 10, thereby providing a maximum surface area for contact with mixing fluid also exiting from the beverage dispensing nozzle 10. Although the preferred embodiment discloses annuluses 17-19, one of ordinary skill in the art will recognize that alternative shapes, such as elliptical or polygonal, may be utilized.

The cap member 11 includes beverage syrup inlet ports 21-23 that communicate with a respective beverage syrup outlet port 24-26 via a respective connecting conduit 37-39 through the cap member 11 (refer to Figs. 1,2, and 7-9). The cap member 11 includes protrusion 35 to aid in the securing of the inner housing 16 to the cap member 11. The beverage syrup outlet ports 24-26 snap fit within a respective cavity 41-42 of the inner housing 16 to secure the inner housing 16 to the cap member 11. The gaskets 13-15 fit around a respective beverage syrup outlet port 24-26 to provide a fluid seal and to assist in the securing of the inner housing 16 to the cap member 11. In addition, the securing member 60 of the third or inner annulus 19 extending through the opening 44 of the inner housing 16 snap fits around the protrusion 35 of the cap member 11 to aid in the securing of the inner housing 16 to the cap member 11. With the inner housing 16 secured to the cap member 11, a beverage syrup path involving the beverage syrup inlet port 21; the conduit 37; the beverage syrup outlet port 24; the cavity 41; the conduit 45; and the annular channel 58, which includes the discharge channels 59 is created. A beverage syrup path involving the beverage syrup inlet port 22; the conduit 38; the beverage syrup outlet port 25; the cavity 42; the conduit 46; the annular channel 54, which includes the discharge channels 55; and one involving the beverage syrup inlet port 23; the conduit 39; the beverage syrup outlet port 26; the cavity 43; the conduit 47;

the annular channel 64, which includes the discharge channels 63; are also created.

The cap member 11 includes a mixing fluid inlet port 27 that communicates with mixing fluid outlet channels 66-71 via a connecting conduit 28 through the cap member 11 (refer to Figs. 1-3 and 6). The mixing fluid outlet channels 66-71 in this first
5 embodiment are uniformly spaced within the cap member 11 and communicate with an annular cavity 36 defined by a portion of the cap member 11 to deliver mixing fluid along the entire circumference of the annular cavity 36. In this first embodiment, the preferred mixing fluid is carbonated water, which forms a carbonated beverage drink when combined with a beverage syrup. Nevertheless, one of ordinary skill in the art will
10 recognize that other mixing fluids, such as plain water may be used. Furthermore, although the preferred embodiment discloses the formation of a beverage from a beverage syrup and a mixing fluid, such as carbonated or plain water, one of ordinary skill in the art will recognize that a mixing fluid, such as carbonated or plain water, may be dispensed individually from a beverage path as described above instead of a beverage
15 syrup.

The cap member 20 includes dog ears 29 and 30 that permit the connection of the cap member 11 to a standard dispensing valve using suitable and well known means. Each of the beverage syrup inlet ports 21-23 receives a beverage syrup conduit to supply the beverage dispensing nozzle 10 with a beverage syrup. Similarly, the mixing fluid
20 inlet port 27 receives a mixing fluid conduit to supply the beverage dispensing nozzle 10 with a mixing fluid. A fastening clip secured to each of bosses 31-33, utilizing a screw or other suitable means, maintains the beverage syrup conduits coupled with a respective beverage syrup inlet port 21-23 and the mixing fluid conduit coupled with the mixing fluid inlet port 27. The cap member 11 includes a groove 34 for receiving the o-ring 12
25 therein.

The outer housing 20 snap fits over the cap member 11, including the o-ring 12 which provides a fluid seal and assists in the securing of the outer housing 16 to the cap member 11. The outer housing 20 includes flanges 74 and 75 and tabs 76 and 77 to mount the outer housing 20 to a standard dispensing valve in well known manner. The
30 outer housing 20 further includes an inwardly extending lip portion 73 at its exit end. The interior wall of the outer housing 20 in combination with the portion of the cap member 11 defining the annular cavity 36 and the exterior wall of the inner housing

define an annular channel 72. With the outer housing 20 secured to the cap member 11, a mixing fluid path involving the mixing fluid inlet port 27, the conduit 28, the mixing fluid outlet channels 66-71, and the annular channel 72 is created. Although the preferred embodiment contemplates the dispensing of a mixing fluid, such as carbonated or plain water, in combination with a beverage syrup, one of ordinary skill in the art will recognize that the mixing fluid may be dispensed separately to provide the mixing fluid by itself.

In operation, mixing fluid enters the beverage dispensing nozzle 10 through the mixing fluid inlet port 27 and travels through the conduit 28 to the mixing fluid outlet channels 66-71 for delivery into the annular cavity 36 (refer to Figs. 7-9). The annular cavity 36 receives a large volume of mixing fluid to insure the annular channel 72 remains full for uniform flow around the annular channel 72 as the mixing fluid flows downwardly through the annular channel 72 to the discharge end of the annular channel 72. In the preferred embodiments, the discharge end of the annular channel 72 may be partially closed to increase the momentum of the mixing fluid exiting the annular channel 72 to maintain a uniform distribution of mixing fluid exiting around the entire circumference of the annular channel 72. The inwardly extending lip portion 73 of the outer housing 20 directs the mixing fluid inwardly toward a beverage syrup stream exiting from one of discharge members 53, 57, and 62. The inward directing of the mixing fluid provides for intimate mixing as well as a means for washing the discharge end of the annular channel 72 to prevent syrup carryover.

The beverage syrup inlet ports 21-23 each receive a different flavor of beverage syrup, which is delivered through a conduit by a beverage syrup source (not shown). Each beverage syrup travels through its particular flow path for discharge from the beverage dispensing nozzle 10 as previously described (refer to Figs. 7-9). Illustratively, a beverage syrup delivered to the beverage syrup inlet port 21 flows through the conduit 37, the beverage syrup outlet port 24, the cavity 41, the conduit 45, the annular channel 58, and the discharge channels 59 prior to discharge from the beverage dispensing nozzle 10. The annular channels 54, 58, and 64 provide a large volume of beverage syrup around each of a respective first or outer, second or intermediate, and third or inner annulus for discharge through one of the discharge members 53, 57, and 62. The discharge members 53, 57, and 62 restrict the flow of beverage syrup to insure uniform

distribution of the beverage syrup as it exits from the beverage dispensing nozzle 10, thus insuring a maximum surface area for contact with the mixing fluid exiting from the annular channel 72. Although only one beverage syrup is typically dispensed at a time, it should be understood that more than one beverage syrup may be discharged from the beverage dispensing nozzle 10 at a time to provide a mix of flavors.

An important feature of the beverage dispensing nozzle 10 is the annular discharge of a beverage syrup, whereby the annularly discharged mixing fluid contacts the beverage syrup in mid-air below the dispensing nozzle 10. The annular discharge shape of the beverage syrup and the mixing fluid significantly increases the contact surface area between the two streams, resulting in more effective mixing. Furthermore, the mixture of the beverage syrup and the mixing fluid outside the beverage dispensing nozzle 10 eliminates the sanitary considerations that occur with a mixing chamber interior to the nozzle; namely, the unsanitary build up of bacteria on the interior of the mixing chamber, which is exacerbated due to the stickiness of the beverage syrup.

Although three separate beverage syrup sources with three annuluses have been described, one of ordinary skill in the art will recognize that any number of beverage syrup sources and annuluses could be provided, including a single beverage syrup source and annulus. In addition, the single stream of mixing fluid exiting from the annular channel 72 may be separated into two or more streams.

As illustrated in Figs. 10-12, a second embodiment of the beverage dispensing nozzle 100 is virtually identical in configuration and operation to the first embodiment of the beverage dispensing nozzle 10. Consequently, components for the beverage dispensing nozzle 100 of like configuration and operation to components of the beverage dispensing nozzle 10 have been referenced with like numerals. The beverage dispensing nozzle 100 is configured and operates as the beverage dispensing nozzle 10, except the beverage dispensing nozzle 100 includes a conduit 101 coupled to the conduit 28 to communicate mixing fluid into a center conduit 102 of the third or inner annulus 19. In addition, the third or inner annulus 18 includes an outlet 103 for discharging the mixing fluid interior to a discharged beverage syrup stream. The conduit 28 therefore not only delivers mixing fluid to the mixing fluid outlet channels 66-71 but also to the conduit 101 for delivery to the center conduit 102. The center conduit 102 delivers the mixing fluid through the center of the beverage dispensing nozzle 100, where it exits inside a

beverage syrup stream to enhance mixing of the mixing fluid and beverage syrup. The beverage dispensing nozzle 100 is particularly desirable for use in dispensing single flavor beverage drinks and for use with large volume beverage dispensing nozzles. A diffuser 104 may be positioned within the conduit 101 to direct the mixing fluid onto the sides of the center conduit 102 to prevent a single stream exiting the outlet 103, thereby
5 improving surface contact between the mixing fluid and beverage syrup.

As illustrated in Fig. 13, a third embodiment of the beverage dispensing nozzle 200 is virtually identical in configuration and operation to the first embodiment of the beverage dispensing nozzle 10. Consequently, components for the beverage dispensing
10 nozzle 200 of like configuration and operation to components of the beverage dispensing nozzle 10 have been referenced with like numerals. The beverage dispensing nozzle 200 is configured and operates as the beverage dispensing nozzle 10, except, in the beverage dispensing nozzle 200, the outlet end of the first or outer annulus 17 includes a conical cut-out portion 201, the outlet end of the second or intermediate annulus 18 includes a
15 conical cut-out portion 202, and the outlet end of the third or inner annulus 19 includes a conical cut-out portion 203. When the first or outer annulus 17, the second or intermediate annulus 18, and the third or inner annulus 19 are secured within the inner housing 16, the conical cut-out portions 201, 202, and 203 define a reverse conical beverage syrup outlet 204 that aids in preventing beverage syrup carryover by facilitating
20 the formation of a low pressure region at the beverage syrup outlet 204. During the dispensing of a beverage syrup and a mixing fluid to form a beverage, the low pressure region permits the flow of mixing fluid over the beverage syrup outlet 204, thereby washing the beverage syrup outlet 204 to remove any carryover beverage syrup.

As illustrated in Fig. 14, a fourth embodiment of the beverage dispensing nozzle
25 300 is virtually identical in configuration and operation to the first embodiment of the beverage dispensing nozzle 10. Consequently, components for the beverage dispensing nozzle 300 of like configuration and operation to components of the beverage dispensing nozzle 10 have been referenced with like numerals. The beverage dispensing nozzle 300 is configured and operates as the beverage dispensing nozzle 10, except, in the beverage
30 dispensing nozzle 300, the outlet end of the first or outer annulus 17 includes a concave cut-out portion 301, the outlet end of the second or intermediate annulus 18 includes a concave cut-out portion 302, and the outlet end of the third or inner annulus 19 includes

a concave cut-out portion 303. When the first or outer annulus 17, the second or intermediate annulus 18, and the third or inner annulus 19 are secured within the inner housing 16, the concave cut-out portions 301, 302, and 303 define a concave beverage syrup nozzle outlet 304 that aids in preventing beverage syrup carryover by facilitating the formation of a low pressure region at the beverage syrup outlet 304. During the dispensing of a beverage syrup and a mixing fluid to form a beverage, the low pressure region permits the flow of mixing fluid over the beverage syrup outlet 304, thereby washing the beverage syrup outlet 304 to remove any carryover beverage syrup.

As illustrated in Fig. 15, a fifth embodiment of the beverage dispensing nozzle 400 is virtually identical in configuration and operation to the first embodiment of the beverage dispensing nozzle 10. Consequently, components for the beverage dispensing nozzle 400 of like configuration and operation to components of the beverage dispensing nozzle 10 have been referenced with like numerals. The beverage dispensing nozzle 400 is configured and operates as the beverage dispensing nozzle 10, except, in the beverage dispensing nozzle 400, the outlet end of the first or outer annulus 17 includes a convex protrusion 402, the outlet end of the second or intermediate annulus 18 includes a convex protrusion 403, and the outlet end of the third or inner annulus 19 includes a convex protrusion 404. When the first or outer annulus 17, the second or intermediate annulus 18, and the third or inner annulus 19 are secured within the inner housing 16, the convex protrusions 402, 403, and 404 define a convex beverage syrup nozzle outlet 405 that aids in preventing beverage syrup carryover because the rounded convex shape permits dispensed beverage syrup to flow to the lower portion of the beverage syrup nozzle outlet 405 where it is rinsed off by the flow of the dispensed mixing fluid.

As illustrated in Fig. 16, a sixth embodiment of the beverage dispensing nozzle 500 is virtually identical in configuration and operation to the first embodiment of the beverage dispensing nozzle 10. Consequently, components for the beverage dispensing nozzle 500 of like configuration and operation to components of the beverage dispensing nozzle 10 have been referenced with like numerals. The beverage dispensing nozzle 500 is configured and operates as the beverage dispensing nozzle 10, except, in the beverage dispensing nozzle 500, the outlet end of the first or outer annulus 17 includes a downward sloping edge 502, the outlet end of the second or intermediate annulus 18 includes a downward sloping edge 503, and the outlet end of the third or inner annulus

19 includes a conical edge 504. When the first or outer annulus 17, the second or intermediate annulus 18, and the third or inner annulus 19 are secured within the inner housing 16, the downward sloping edges 502 and 503 and the conical edge 504 define a conical beverage syrup nozzle outlet 505 that aids in preventing beverage syrup carryover because the conical shape permits dispensed beverage syrup to flow to the lower portion of the beverage syrup nozzle outlet 505 where it is rinsed off by the flow of the dispensed mixing fluid.

As illustrated in Fig. 17, a seventh embodiment of the beverage dispensing nozzle 600 is virtually identical in configuration and operation to the first embodiment of the beverage dispensing nozzle 10. Consequently, components for the beverage dispensing nozzle 600 of like configuration and operation to components of the beverage dispensing nozzle 10 have been referenced with like numerals. The beverage dispensing nozzle 600 is configured and operates as the beverage dispensing nozzle 10, except, in the beverage dispensing nozzle 600, the outlet end of the first or outer annulus 17 includes a downward sloping edge 602, the outlet end of the second or intermediate annulus 18 includes a downward sloping edge 603, and the outlet end of the third or inner annulus 19 includes a truncated conical edge 604. When the first or outer annulus 17, the second or intermediate annulus 18, and the third or inner annulus 19 are secured within the inner housing 16, the downward sloping edges 602 and 603 and the truncated conical edge 604 define a truncated conical beverage syrup nozzle outlet 605 that aids in preventing beverage syrup carryover because the truncated conical shape permits dispensed beverage syrup to flow to the lower portion of the beverage syrup nozzle outlet 605 where it is rinsed off by the flow of the dispensed mixing fluid. Furthermore, the flattened portion 606 of the truncated conical beverage syrup nozzle outlet 605 creates a low pressure region that prevents the formation of a beverage syrup bubble as well as aids in the washing of the outlet by the mixing fluid.

As illustrated in Fig. 18, an eighth embodiment of the beverage dispensing nozzle 700 is virtually identical in configuration and operation to the first embodiment of the beverage dispensing nozzle 10. Consequently, components for the beverage dispensing nozzle 700 of like configuration and operation to components of the beverage dispensing nozzle 10 have been referenced with like numerals. The beverage dispensing nozzle 700 is configured and operates as the beverage dispensing nozzle 10, except, in the beverage

dispensing nozzle 700, the outlet end of the first or outer annulus 17 includes a downward cascading edge 702, the outlet end of the second or intermediate annulus 18 includes a downward cascading edge 703, and the outlet end of the third or inner annulus 19 includes a cascading conical edge 704. When the first or outer annulus 17, the second
5 or intermediate annulus 18, and the third or inner annulus 19 are secured within the inner housing 16, the downward cascading edges 702 and 703 and the cascading conical edge 704 define a cascading conical beverage syrup nozzle outlet 705 that aids in preventing beverage syrup carryover because the cascading conical shape permits dispensed beverage syrup to flow to the lower portion of the beverage syrup nozzle outlet 705
10 where it is rinsed off by the flow of the dispensed mixing fluid. Furthermore, the downward cascading edges 702 and 703 and the cascading conical edge 704 create crevices that function as collection points for excess beverage syrup so that, upon subsequent dispenses, the dispensed beverage syrup flows over the collected beverage syrup and does not mix, thereby eliminating beverage syrup carryover.

15 As illustrated in Fig. 19, a ninth embodiment of the beverage dispensing nozzle 800 is virtually identical in configuration and operation to the first embodiment of the beverage dispensing nozzle 10. Consequently, components for the beverage dispensing nozzle 800 of like configuration and operation to components of the beverage dispensing nozzle 10 have been referenced with like numerals. The beverage dispensing nozzle 800
20 is configured and operates as the beverage dispensing nozzle 10, except, in the beverage dispensing nozzle 800, the outlet end of the first or outer annulus 17 includes a downward cascading edge 802, the outlet end of the second or intermediate annulus 18 includes a downward cascading edge 803, and the outlet end of the third or inner annulus 19 includes a cascading truncated conical edge 804. When the first or outer annulus 17,
25 the second or intermediate annulus 18, and the third or inner annulus 19 are secured within the inner housing 16, the downward cascading edges 802 and 803 and the cascading truncated conical edge 804 define a cascading truncated conical beverage syrup nozzle outlet 805 that aids in preventing beverage syrup carryover because the cascading truncated conical shape permits dispensed beverage syrup to flow to the lower
30 portion of the beverage syrup nozzle outlet 805 where it is rinsed off by the flow of the dispensed mixing fluid. Furthermore, the downward cascading edges 802 and 803 and the cascading conical edge 804 create crevices that function as collection points for

excess beverage syrup so that, upon subsequent dispenses, the dispensed beverage syrup flows over the collected beverage syrup and does not mix, thereby eliminating beverage syrup carryover. In addition, the flattened portion 806 of the cascading truncated conical beverage syrup nozzle outlet 805 creates a low pressure region that prevents the
5 formation of a beverage syrup bubble as well as aids in the washing of the outlet by the mixing fluid.

As illustrated in Fig. 20, a tenth embodiment of the beverage dispensing nozzle 900 is virtually identical in configuration and operation to the first embodiment of the beverage dispensing nozzle 10. Consequently, components for the beverage dispensing
10 nozzle 900 of like configuration and operation to components of the beverage dispensing nozzle 10 have been referenced with like numerals. The beverage dispensing nozzle 900 is configured and operates as the beverage dispensing nozzle 10, except, the third or inner annulus 919 and the cap member 911 include modifications to permit the delivery of flavor additives from the beverage dispensing nozzle 900 along with beverage syrup
15 and mixing fluid. Examples of flavor additives in this tenth embodiment include, but are not limited to, cherry or vanilla, which are utilized to form new drink combinations such as cherry cola.

The third or inner annulus 919 includes a securing member 960, an intermediate member 961, and a discharge member 962. The third or inner annulus 919 mounts within
20 the second or intermediate annulus 18, protrudes through the opening of the inner housing, and engages the interior wall of the inner housing 16 defining the opening identically as previously described with reference to the beverage dispensing nozzle 10. The third or inner annulus 919, however, includes passageways 907 and 908 therethrough, which are utilized to deliver flavor additives from the third or inner
25 annulus 919. The intermediate member 961 and the discharge member 962 are identical to the intermediate member 61 and the discharge member 62 of the third or inner annulus 19, except, the intermediate member 961 and the discharge member 962 define a portion of the passageways 907 and 908. The securing member 960 is identical to the securing member 60 of the third or inner annulus 919, except, the securing member 60 defines a
30 cavity 909 as well as a portion of the passageways 907 and 908.

The cap member 911 is configured and operates as the cap member 11, except, the cap member 911 further includes flavor additive inlet ports 901 and 902 that

communicate with a respective flavor additive outlet port 903 and 904 via a respective connecting passageway 905 and 906 through the cap member 911. Identical to the cap member 11, beverage syrup outlet ports of the cap member 911 snap fit within a respective cavity of the inner housing 16 to secure the inner housing 16 to the cap member 911. Gaskets fit around a respective beverage syrup outlet port to provide a fluid seal and to assist in the securing of the inner housing 16 to the cap member 911. In addition, the securing member 960 of the third or inner annulus 919 extending through the opening of the inner housing 16 snap fits around the protrusion 35 of the cap member 911 to aid in the securing of the inner housing 16 to the cap member 911. With the inner housing 16 secured to the cap member 911, a flavor additive conduit involving the flavor additive inlet port 901; the passageway 905; the flavor additive outlet port 903; and the passageway 907 is created. Similarly, a flavor additive conduit involving the flavor additive inlet port 902; the passageway 906; the flavor additive outlet port 904; and the passageway 908 is created.

The operation of the beverage dispensing nozzle 900 in delivering a mixing fluid for combination with a beverage syrup to produce a desired drink is identical to the operation of the beverage dispensing nozzle 10. However, the beverage dispensing nozzle 900 provides a user the option of altering drink flavor through the addition of flavor additives, such as cherry or vanilla, delivered from flavor additive sources. When the user has selected a flavor additive, the flavor additive enters a respective flavor additive inlet port 901 or 902 and travels to a respective passageway 907 or 908 via a respective passageway 905 or 906 and flavor additive outlet port 903 and 904. The selected additive flavor traverses a respective passageway 907 or 908 and exits the third or inner annulus 919, where the flavor additive combines with the flowing beverage syrup and mixing fluid to produce an alternatively flavored drink, such as cherry or vanilla cola.

Although the present invention has been described in terms of the foregoing embodiment, such description has been for exemplary purposes only and, as will be apparent to one of ordinary skill in the art, many alternatives, equivalents, and variations of varying degrees will fall within the scope of the present invention. That scope, accordingly, is not to be limited in any respect by the foregoing description, rather, it is defined only by the claims that follow.

THE CLAIMS DEFINING THE INVENTION ARE AS FOLLOWS:

1. A beverage dispensing nozzle, comprising:
 - a cap member comprising a first beverage syrup inlet port coupled to a first beverage syrup source and a mixing fluid inlet port coupled to a mixing fluid source;
 - an inner housing coupled to the cap member, wherein the inner housing defines a chamber;
 - a first annulus disposed within the chamber of the inner housing, the first annulus and the inner housing defining a first beverage syrup channel, wherein the first beverage syrup inlet port communicates beverage syrup to the first beverage syrup channel for discharge from the beverage dispensing nozzle substantially undiluted with mixing fluid; and
 - an outer housing coupled to the cap member, the outer housing and the inner housing defining a mixing fluid channel, wherein the mixing fluid inlet port communicates mixing fluid to the mixing fluid channel for discharge from the beverage dispensing nozzle for contact with exiting beverage syrup to mix therewith outside the beverage dispensing nozzle.

2. The beverage dispensing nozzle according to claim 1, wherein the first beverage syrup channel discharges the beverage syrup from the beverage dispensing nozzle in an annular flow pattern.

3. The beverage dispensing nozzle according to claim 1, wherein the mixing fluid channel discharges the mixing fluid from the beverage dispensing nozzle in an annular flow pattern.

4. The beverage dispensing nozzle according to claim 1, wherein the inner housing includes a first cavity therein connected with a first inner housing conduit that communicates with the first beverage syrup channel.

5. The beverage dispensing nozzle according to claim 4, wherein the cap member comprises a first beverage syrup outlet port connected with the first beverage syrup inlet port, wherein the first beverage syrup outlet port fits within the first cavity of the inner housing to couple the inner housing to the cap member and to communicate beverage syrup to the inner housing.

6. The beverage dispensing nozzle according to claim 1, wherein the cap member comprises a plurality of mixing fluid outlet channels connected to the mixing



fluid inlet port and communicating with the mixing fluid channel for circumferentially delivering mixing fluid into the mixing fluid channel.

7. The beverage dispensing nozzle according to claim 1, wherein the cap member comprises a conduit connected to the mixing fluid inlet port and communicating with the inner housing for delivering mixing fluid through the center of the beverage dispensing nozzle.

8. The beverage dispensing nozzle according to claim 7, wherein a diffuser resides within the conduit for delivering mixing fluid through the center of the beverage dispensing nozzle.

9. The beverage dispensing nozzle according to claim 2, wherein the first annulus comprises a discharge member that restricts the annular flow pattern of the beverage syrup exiting the beverage dispensing nozzle to insure a uniform distribution.

10. The beverage dispensing nozzle according to claim 9, wherein the discharge member includes a plurality of discharge channels that aid the first beverage syrup channel in discharging the beverage syrup from the beverage dispensing nozzle.

11. The beverage dispensing nozzle according to claim 1, wherein the outer housing includes an inwardly extending lip portion for directing inward the flow of mixing fluid exiting the beverage dispensing nozzle.

12. The beverage dispensing nozzle according to claim 1, wherein the cap member further comprises a second beverage syrup inlet port coupled to a second beverage syrup source.

13. The beverage dispensing nozzle according to claim 12, further comprising a second annulus disposed within the chamber of the inner housing, the second annulus and the first annulus defining a second beverage syrup channel, wherein the second beverage syrup inlet port communicates beverage syrup to the second beverage syrup channel for discharge from the beverage dispensing nozzle.

14. The beverage dispensing nozzle according to claim 13, wherein the second beverage syrup channel discharges the beverage syrup from the beverage dispensing nozzle substantially undiluted with mixing fluid.

15. The beverage dispensing nozzle according to claim 13, wherein the second beverage syrup channel discharges the beverage syrup from the beverage dispensing nozzle in an annular flow pattern.

16. The beverage dispensing nozzle according to claim 13, wherein the inner housing includes a second cavity therein connected with a second inner housing conduit

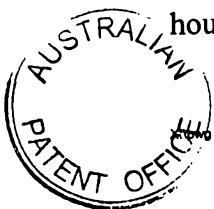

that communicates with the second beverage syrup channel.

17. The beverage dispensing nozzle according to claim 16, wherein the cap member further comprises a second beverage syrup outlet port connected with the second beverage syrup inlet port, wherein the second beverage syrup outlet port fits within the second cavity of the inner housing to couple the inner housing to the cap member and to communicate beverage syrup to the inner housing.

18. The beverage dispensing nozzle according to claim 15, wherein the second annulus comprises a discharge member that restricts the annular flow pattern of the beverage syrup exiting the beverage dispensing nozzle to insure a uniform distribution.

19. The beverage dispensing nozzle according to claim 18, wherein the discharge member includes a plurality of discharge channels that aid the second beverage syrup channel in discharging the beverage syrup from the beverage dispensing nozzle.

20. The beverage dispensing nozzle according to claim 14, wherein the cap member further comprises a third beverage syrup inlet port coupled to a third beverage syrup source.

21. The beverage dispensing nozzle according to claim 21, further comprising a third annulus disposed within the chamber of the inner housing, the third annulus and the second annulus defining a third beverage syrup channel, wherein the third beverage syrup inlet port communicates beverage syrup to the third beverage syrup channel for discharge from the beverage dispensing nozzle.

22. The beverage dispensing nozzle according to claim 21, wherein the third beverage syrup channel discharges the beverage syrup from the beverage dispensing nozzle substantially undiluted with mixing fluid.

23. The beverage dispensing nozzle according to claim 21, wherein the third beverage syrup channel discharges the beverage syrup from the beverage dispensing nozzle in an annular flow pattern.

24. The beverage dispensing nozzle according to claim 21, wherein the inner housing includes a third cavity therein connected with a third inner housing conduit that communicates with the third beverage syrup channel.

25. The beverage dispensing nozzle according to claim 24, wherein the cap member further comprises a third beverage syrup outlet port connected with the third beverage syrup inlet port, wherein the third beverage syrup outlet port fits within the

third cavity of the inner housing to couple the inner housing to the cap member and to communicate beverage syrup to the inner housing.

26. The beverage dispensing nozzle according to claim 23, wherein the third annulus comprises a discharge member that restricts the annular flow pattern of the beverage syrup exiting the beverage dispensing nozzle to insure a uniform distribution.

27. The beverage dispensing nozzle according to claim 26, wherein the discharge member includes a plurality of discharge channels that aid the third beverage syrup channel in discharging the beverage syrup from the beverage dispensing nozzle.

28. The beverage dispensing nozzle according to claim 1, wherein the first annulus includes an irregularly shaped outlet that manipulates the flow pattern of the beverage syrup to prevent beverage syrup carryover.

29. The beverage dispensing nozzle according to claim 13, wherein the second annulus includes an irregularly shaped outlet that manipulates the flow pattern of the beverage syrup to prevent beverage syrup carryover.

30. The beverage dispensing nozzle according to claim 21, wherein the third annulus includes an irregularly shaped outlet that manipulates the flow pattern of the beverage syrup to prevent beverage syrup carryover.

31. The beverage dispensing nozzle according to claim 13, wherein the first annulus and the second annulus align to define an irregularly shaped beverage syrup outlet that manipulates the flow pattern of the beverage syrup to prevent beverage syrup carryover.

32. The beverage dispensing nozzle according to claim 21, wherein the first annulus, the second annulus, and the third annulus align to define an irregularly shaped beverage syrup outlet that manipulates the annular flow pattern of the beverage syrup to prevent beverage syrup carryover.

33. The beverage dispensing nozzle according to claim 21, wherein the first annulus, the second annulus, and the third annulus align to define a reverse conical beverage syrup outlet that manipulates the flow pattern of the beverage syrup to prevent beverage syrup carryover.

34. The beverage dispensing nozzle according to claim 21, wherein the first annulus, the second annulus, and the third annulus align to define a concave beverage syrup outlet that manipulates the flow pattern of the beverage syrup to prevent beverage syrup carryover.

35. The beverage dispensing nozzle according to claim 21, wherein the first

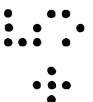
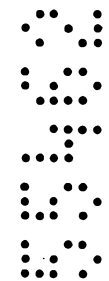

annulus, the second annulus, and the third annulus align to define a convex beverage syrup outlet that manipulates the flow pattern of the beverage syrup to prevent beverage syrup carryover.

36. The beverage dispensing nozzle according to claim 21, wherein the first annulus, the second annulus, and the third annulus align to define a conical beverage syrup outlet that manipulates the flow pattern of the beverage syrup to prevent beverage syrup carryover.

37. The beverage dispensing nozzle according to claim 21, wherein the first annulus, the second annulus, and the third annulus align to define a truncated conical beverage syrup outlet that manipulates the flow pattern of the beverage syrup to prevent beverage syrup carryover.

38. The beverage dispensing nozzle according to claim 21, wherein the first annulus, the second annulus, and the third annulus align to define a cascading conical beverage syrup outlet that manipulates the flow pattern of the beverage syrup to prevent beverage syrup carryover.

39. The beverage dispensing nozzle according to claim 21, wherein the first annulus, the second annulus, and the third annulus align to define a cascading truncated conical beverage syrup outlet that manipulates the flow pattern of the beverage syrup to prevent beverage syrup carryover.

40. The beverage dispensing nozzle according to claim 1, wherein the cap member further comprises a flavor additive inlet port coupled to a flavor additive source.

41. The beverage dispensing nozzle according to claim 40, wherein the flavor additive inlet port communicates flavor additive to a flavor additive passageway of the first annulus for discharge from the beverage dispensing nozzle.

42. The beverage dispensing nozzle according to claim 41, wherein the cap member comprises a flavor additive outlet port connected with the flavor additive inlet port, wherein the flavor additive outlet port communicates flavor additive to the flavor additive passageway.

43. A beverage dispensing nozzle, comprising:

a cap member comprising a first beverage syrup inlet port coupled to a first beverage syrup source, a second beverage syrup inlet port coupled to a second beverage syrup source, and a mixing fluid inlet port coupled to a mixing fluid source;



an inner housing coupled to the cap member, wherein the inner housing defines a chamber;

a first annulus disposed within the chamber of the inner housing, the first annulus and the inner housing defining a first beverage syrup channel, wherein the first beverage syrup inlet port communicates beverage syrup to the first beverage syrup channel for discharge from the beverage dispensing nozzle;

a second annulus disposed within the chamber of the inner housing, the second annulus and the first annulus defining a second beverage syrup channel, wherein the second beverage syrup inlet port communicates beverage syrup to the second beverage syrup channel for discharge from the beverage dispensing nozzle; and

an outer housing coupled to the cap member, the outer housing and the inner housing defining a mixing fluid channel, wherein the mixing fluid inlet port communicates mixing fluid to the mixing fluid channel for discharge from the beverage dispensing nozzle and mixing with exiting beverage syrup.

44. The beverage dispensing nozzle according to claim 43, wherein the inner housing includes a first cavity therein connected with a first inner housing conduit that communicates with the first beverage syrup channel.

45. The beverage dispensing nozzle according to claim 44, wherein the cap member comprises a first beverage syrup outlet port connected with the first beverage syrup inlet port, wherein the first beverage syrup outlet port fits within the first cavity of the inner housing to couple the inner housing to the cap member and to communicate beverage syrup to the inner housing.

46. The beverage dispensing nozzle according to claim 43, wherein the cap member comprises a plurality of mixing fluid outlet channels connected to the mixing fluid inlet port and communicating with the mixing fluid channel for circumferentially delivering mixing fluid into the mixing fluid channel.

47. The beverage dispensing nozzle according to claim 43, wherein the cap member comprises a conduit connected to the mixing fluid inlet port and communicating with the inner housing for delivering mixing fluid through the center of the beverage dispensing nozzle.

48. The beverage dispensing nozzle according to claim 43, wherein a diffuser resides within the conduit for delivering mixing fluid through the center of the beverage dispensing nozzle.



49. The beverage dispensing nozzle according to claim 43, wherein the first annulus comprises a discharge member that restricts the flow pattern of the beverage syrup exiting the beverage dispensing nozzle to insure a uniform distribution.

50. The beverage dispensing nozzle according to claim 49, wherein the discharge member includes a plurality of discharge channels that aid the first beverage syrup channel in discharging the beverage syrup from the beverage dispensing nozzle.

51. The beverage dispensing nozzle according to claim 43, wherein the outer housing includes an inwardly extending lip portion for directing inward the flow of mixing fluid exiting the beverage dispensing nozzle.

52. The beverage dispensing nozzle according to claim 43, wherein the inner housing includes a second cavity therein connected with a second inner housing conduit that communicates with the second beverage syrup channel.

53. The beverage dispensing nozzle according to claim 52, wherein the cap member further comprises a second beverage syrup outlet port connected with the second beverage syrup inlet port, wherein the second beverage syrup outlet port fits within the second cavity of the inner housing to couple the inner housing to the cap member and to communicate beverage syrup to the inner housing.

54. The beverage dispensing nozzle according to claim 43, wherein the second annulus comprises a discharge member that restricts the flow pattern of the beverage syrup exiting the beverage dispensing nozzle to insure a uniform distribution.

55. The beverage dispensing nozzle according to claim 54, wherein the discharge member includes a plurality of discharge channels that aid the second beverage syrup channel in discharging the beverage syrup from the beverage dispensing nozzle.

56. The beverage dispensing nozzle according to claim 43, wherein the cap member further comprises a third beverage syrup inlet port coupled to a third beverage syrup source.

57. The beverage dispensing nozzle according to claim 56, further comprising a third annulus disposed within the chamber of the inner housing, the third annulus and the second annulus defining a third beverage syrup channel, wherein the third beverage syrup inlet port communicates beverage syrup to the third beverage syrup channel for discharge from the beverage dispensing nozzle.

58. The beverage dispensing nozzle according to claim 57, wherein the inner housing includes a third cavity therein connected with a third inner housing conduit that

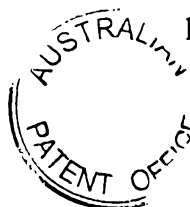
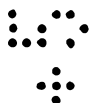
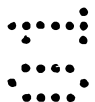
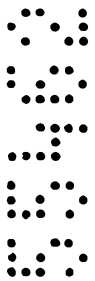

communicates with the third beverage syrup channel.

59. The beverage dispensing nozzle according to claim 58, wherein the cap member further comprises a third beverage syrup outlet port connected with the third beverage syrup inlet port, wherein the third beverage syrup outlet port fits within the third cavity of the inner housing to couple the inner housing to the cap member and to communicate beverage syrup to the inner housing.

60. The beverage dispensing nozzle according to claim 57, wherein the third annulus comprises a discharge member that restricts the flow pattern of the beverage syrup exiting the beverage dispensing nozzle to insure a uniform distribution.

61. The beverage dispensing nozzle according to claim 60, wherein the discharge member includes a plurality of discharge channels that aid the third beverage syrup channel in discharging the beverage syrup from the beverage dispensing nozzle.

62. The beverage dispensing nozzle according to claim 43, wherein the first annulus includes an irregularly shaped outlet that manipulates the flow pattern of the beverage syrup to prevent beverage syrup carryover.

63. The beverage dispensing nozzle according to claim 43, wherein the second annulus includes an irregularly shaped outlet that manipulates the flow pattern of the beverage syrup to prevent beverage syrup carryover.

64. The beverage dispensing nozzle according to claim 57, wherein the third annulus includes an irregularly shaped outlet that manipulates the flow pattern of the beverage syrup to prevent beverage syrup carryover.

65. The beverage dispensing nozzle according to claim 43, wherein the first annulus and the second annulus align to define an irregularly shaped beverage syrup outlet that manipulates the flow pattern of the beverage syrup to prevent beverage syrup carryover.

66. The beverage dispensing nozzle according to claim 57, wherein the first annulus, the second annulus, and the third annulus align to define an irregularly shaped beverage syrup outlet that manipulates the flow pattern of the beverage syrup to prevent beverage syrup carryover.

67. The beverage dispensing nozzle according to claim 57, wherein the first annulus, the second annulus, and the third annulus align to define a reverse conical beverage syrup outlet that manipulates the flow pattern of the beverage syrup to prevent beverage syrup carryover.

68. The beverage dispensing nozzle according to claim 57, wherein the first

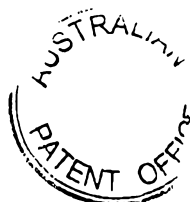

annulus, the second annulus, and the third annulus align to define a concave beverage syrup outlet that manipulates the flow pattern of the beverage syrup to prevent beverage syrup carryover.

69. The beverage dispensing nozzle according to claim 57, wherein the first annulus, the second annulus, and the third annulus align to define a convex beverage syrup outlet that manipulates the flow pattern of the beverage syrup to prevent beverage syrup carryover.

70. The beverage dispensing nozzle according to claim 57, wherein the first annulus, the second annulus, and the third annulus align to define a conical beverage syrup outlet that manipulates the flow pattern of the beverage syrup to prevent beverage syrup carryover.

71. The beverage dispensing nozzle according to claim 57, wherein the first annulus, the second annulus, and the third annulus align to define a truncated conical beverage syrup outlet that manipulates the flow pattern of the beverage syrup to prevent beverage syrup carryover.

72. The beverage dispensing nozzle according to claim 57, wherein the first annulus, the second annulus, and the third annulus align to define a cascading conical beverage syrup outlet that manipulates the flow pattern of the beverage syrup to prevent beverage syrup carryover.

73. The beverage dispensing nozzle according to claim 57, wherein the first annulus, the second annulus, and the third annulus align to define a cascading truncated conical beverage syrup outlet that manipulates the flow pattern of the beverage syrup to prevent beverage syrup carryover.

74. The beverage dispensing nozzle according to claim 43, wherein the cap member further comprises a flavor additive inlet port coupled to a flavor additive source.

75. The beverage dispensing nozzle according to claim 74, wherein the flavor additive inlet port communicates flavor additive to a flavor additive passageway of the second annulus for discharge from the beverage dispensing nozzle.

76. The beverage dispensing nozzle according to claim 75, wherein the cap member comprises a flavor additive outlet port connected with the flavor additive inlet port, wherein the flavor additive outlet port communicates flavor additive to the flavor additive passageway.

77. A method of forming a beverage drink utilizing a beverage dispensing



nozzle, comprising the steps of:

delivering a beverage syrup to a first beverage syrup inlet port of a cap member;

delivering a mixing fluid to a mixing fluid inlet port of the cap member;

delivering the beverage syrup from the first beverage syrup inlet port to a first channel defined by an inner housing coupled with the cap member and a first annulus disposed in the inner housing;

discharging the beverage syrup from the first annular beverage syrup channel substantially undiluted with mixing fluid;

delivering the mixing fluid from the mixing fluid inlet port to a mixing fluid channel defined by an outer housing coupled to the cap member and the inner housing; and

discharging the mixing fluid from the mixing fluid channel for contact with exiting beverage syrup to mix therewith outside the beverage dispensing nozzle.

78. The method of forming a beverage drink utilizing a beverage dispensing nozzle according to claim 77, further comprising the step of discharging the beverage syrup from the first beverage syrup channel in an annular flow pattern.

79. The method of forming a beverage drink utilizing a beverage dispensing nozzle according to claim 77, further comprising the step of discharging the mixing fluid from the mixing fluid channel in an annular flow pattern.

80. The method of forming a beverage drink utilizing a beverage dispensing nozzle according to claim 77, further comprising the steps of:

delivering a beverage syrup to a second beverage syrup inlet port of the cap member;

delivering the beverage syrup from the second beverage syrup inlet port to a second channel defined by a second annulus disposed in the inner housing and the first annulus; and

discharging the beverage syrup from the second annular beverage syrup channel.

81. The method of forming a beverage drink utilizing a beverage dispensing nozzle according to claim 80, further comprising the step of discharging the beverage syrup from the second beverage syrup channel substantially undiluted with mixing fluid.

82. The method of forming a beverage drink utilizing a beverage dispensing



nozzle according to claim 80, further comprising the step of discharging the beverage syrup from the second beverage syrup channel in an annular flow pattern.

83. The method of forming a beverage drink utilizing a beverage dispensing nozzle according to claim 80, further comprising the steps of:

delivering a beverage syrup to a third beverage syrup inlet port of the cap member;

delivering the beverage syrup from the third beverage syrup inlet port to a third channel defined by a third annulus disposed in the inner housing and the second annulus; and

discharging the beverage syrup from the third annular beverage syrup channel.

84. The method of forming a beverage drink utilizing a beverage dispensing nozzle according to claim 83, further comprising the step of discharging the beverage syrup from the third beverage syrup channel substantially undiluted with mixing fluid.

85. The method of forming a beverage drink utilizing a beverage dispensing nozzle according to claim 83, further comprising the step of discharging the beverage syrup from the third beverage syrup channel in an annular flow pattern.

86. The method of forming a beverage drink utilizing a beverage dispensing nozzle according to claim 77, further comprising the steps of:

delivering the mixing fluid from the mixing fluid inlet port fluid through the center of the beverage dispensing nozzle; and

discharging the mixing fluid from the center of the beverage dispensing nozzle to contact exiting beverage syrup mix therewith outside the beverage dispensing nozzle.

87. The method of forming a beverage drink utilizing a beverage dispensing nozzle according to claim 77, further comprising the step of manipulating the flow pattern of the discharged beverage syrup to prevent beverage syrup carryover utilizing an irregularly shaped outlet of the first annulus.

88. The method of forming a beverage drink utilizing a beverage dispensing nozzle according to claim 80, further comprising the step of manipulating the flow pattern of the discharged beverage syrup to prevent beverage syrup carryover utilizing an irregularly shaped outlet of the second annulus.

89. The method of forming a beverage drink utilizing a beverage dispensing nozzle according to claim 83, further comprising the step of manipulating the flow



pattern of the discharged beverage syrup to prevent beverage syrup carryover utilizing an irregularly shaped outlet of the third annulus.

90. The method of forming a beverage drink utilizing a beverage dispensing nozzle according to claim 77, further comprising the steps of:

delivering a flavor additive to a flavor additive inlet port of the cap member;

delivering the flavor additive from the flavor additive inlet port to a flavor additive passageway within the first annulus;

discharging the flavor additive from the first annulus.

91. A method of forming a beverage drink utilizing a beverage dispensing nozzle, comprising the steps of:

delivering a beverage syrup to a first beverage syrup inlet port of a cap member;

delivering a beverage syrup to a second beverage syrup inlet port of the cap member;

delivering a mixing fluid to a mixing fluid inlet port of the cap member;

delivering the beverage syrup from the first beverage syrup inlet port to a first channel defined by an inner housing coupled with the cap member and a first annulus disposed in the inner housing;

discharging the beverage syrup from the first beverage syrup channel;

delivering the beverage syrup from the second beverage syrup inlet port to a second channel defined by a second annulus disposed in the inner housing and the first annulus;

discharging the beverage syrup from the second beverage syrup channel;

delivering the mixing fluid from the mixing fluid inlet port to a mixing fluid channel defined by an outer housing coupled to the cap member and the inner housing; and

discharging the mixing fluid from the mixing fluid channel for mixing with exiting beverage syrup.

92. The method of forming a beverage drink utilizing a beverage dispensing nozzle according to claim 91, further comprising the steps of:

delivering a beverage syrup to a third beverage syrup inlet port of the cap member;



delivering the beverage syrup from the third beverage syrup inlet port to a third channel defined by a third annulus disposed in the inner housing and the second annulus; and

discharging the beverage syrup from the third beverage syrup channel.

93. The method of forming a beverage drink utilizing a beverage dispensing nozzle according to claim 91, further comprising the steps of:

delivering the mixing fluid from the mixing fluid inlet port fluid through the center of the beverage dispensing nozzle; and

discharging the mixing fluid from the center of the beverage dispensing nozzle for mixing with exiting beverage syrup.

94. The method of forming a beverage drink utilizing a beverage dispensing nozzle according to claim 91, further comprising the step of manipulating the flow pattern of the discharged beverage syrup to prevent beverage syrup carryover utilizing an irregularly shaped outlet of the first annulus.

95. The method of forming a beverage drink utilizing a beverage dispensing nozzle according to claim 91, further comprising the step of manipulating the flow pattern of the discharged beverage syrup to prevent beverage syrup carryover utilizing an irregularly shaped outlet of the second annulus.

96. The method of forming a beverage drink utilizing a beverage dispensing nozzle according to claim 92, further comprising the step of manipulating the flow pattern of the discharged beverage syrup to prevent beverage syrup carryover utilizing an irregularly shaped outlet of the third annulus.

97. The method of forming a beverage drink utilizing a beverage dispensing nozzle according to claim 91, further comprising the steps of:

delivering a flavor additive to a flavor additive inlet port of the cap member;

delivering the flavor additive from the flavor additive inlet port to a flavor additive passageway within the second annulus;

discharging the flavor additive from the second annulus.

98. A beverage dispensing nozzle substantially as herein described with reference to any one of the embodiments illustrated in the accompanying drawings.

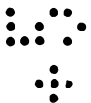
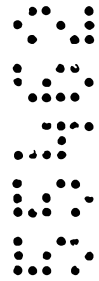

99. A method of forming a beverage drink utilizing a beverage dispensing nozzle substantially as herein described with reference to any one of the embodiments illustrated in the accompanying drawings.

DATED: 2 February 2001

PHILLIPS ORMONDE & FITZPATRICK

Attorneys for:

David B Fitzpatrick

LANCER PARTNERSHIP, LTD.

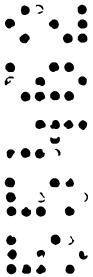

1/15

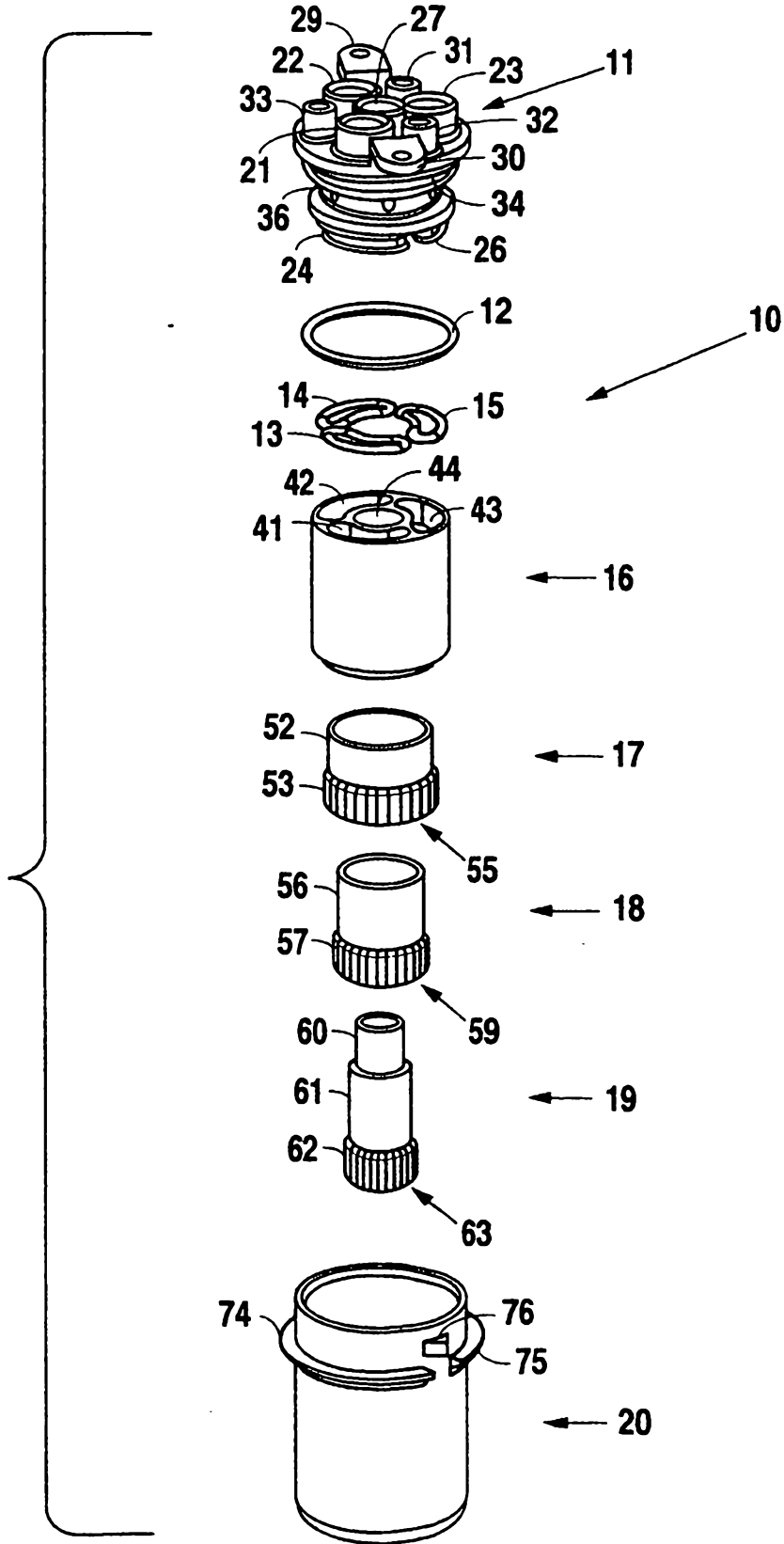

Fig. 1

2/15

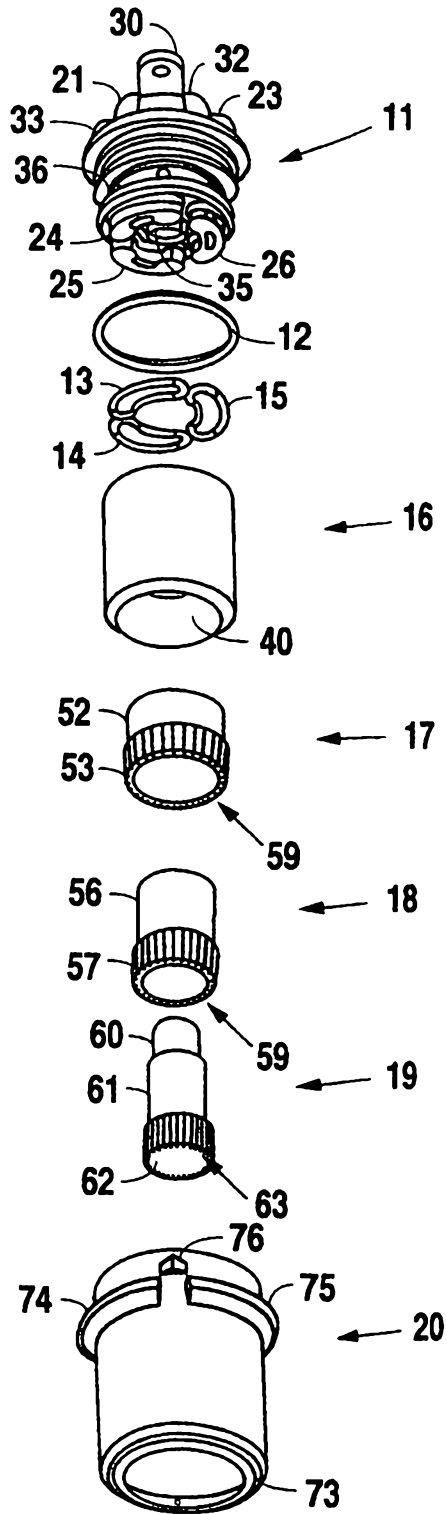

Fig. 2

3/15

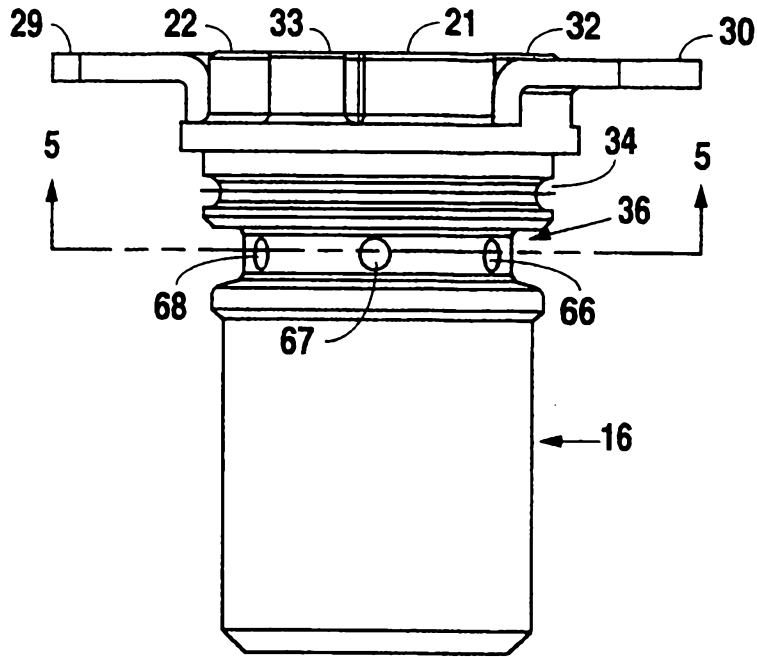

Fig. 3

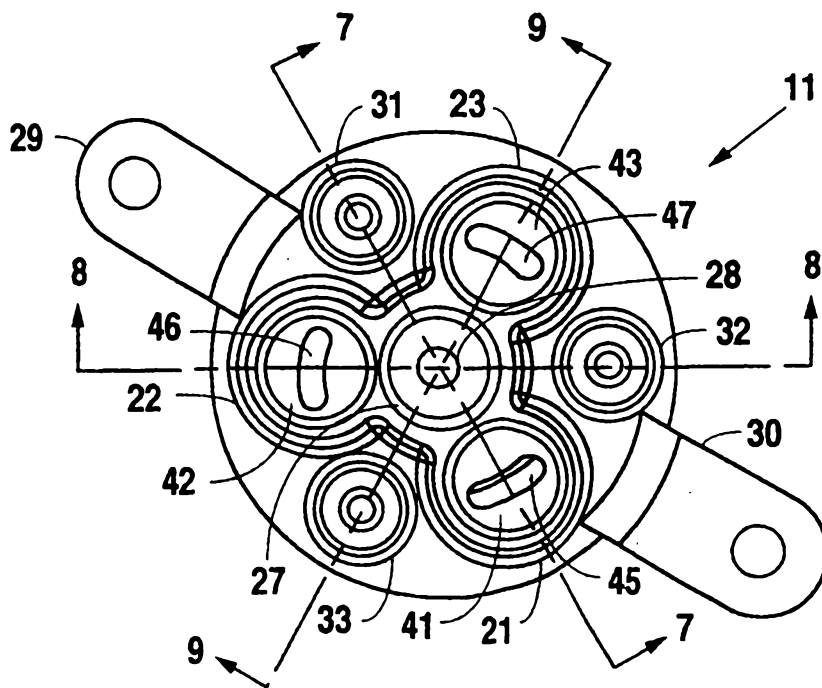

Fig. 4

4/15

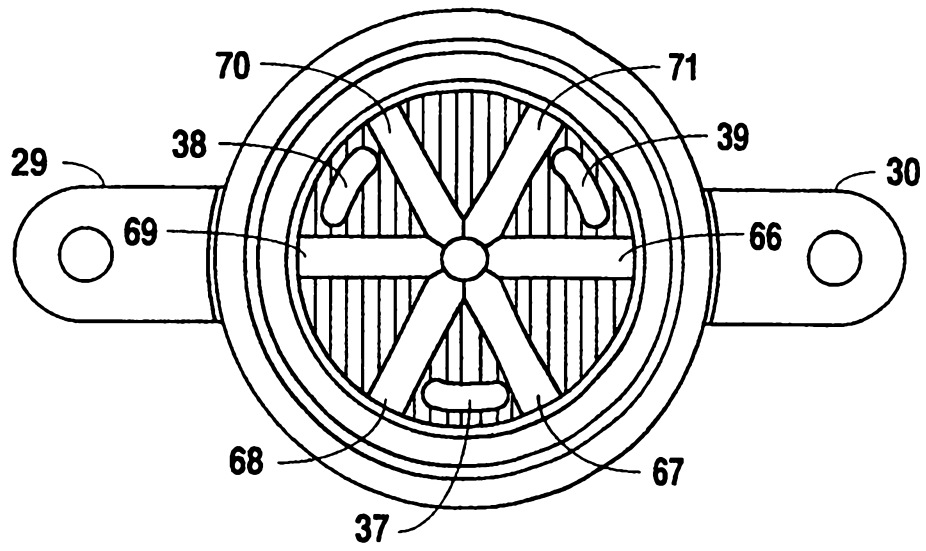

Fig. 5

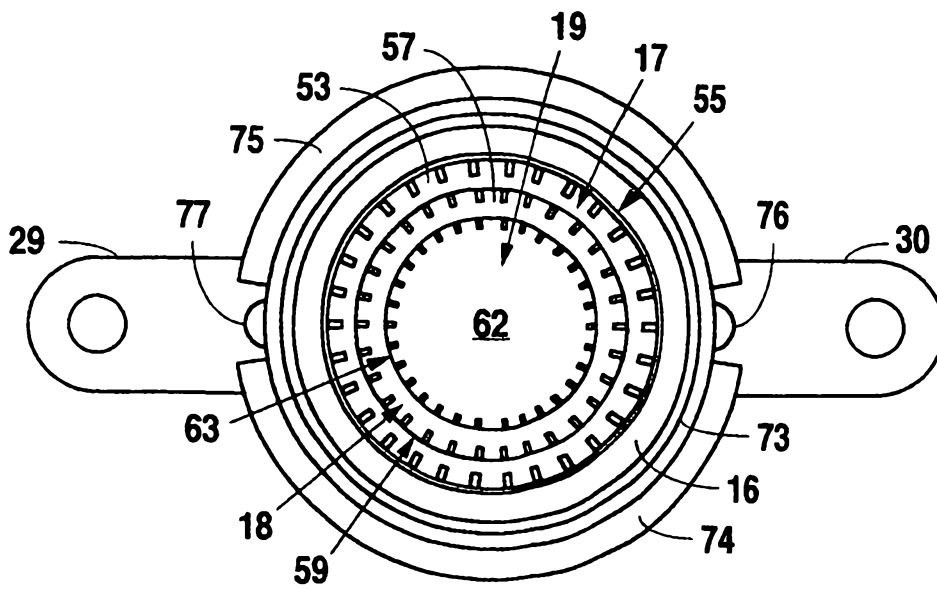

Fig. 6

5/15

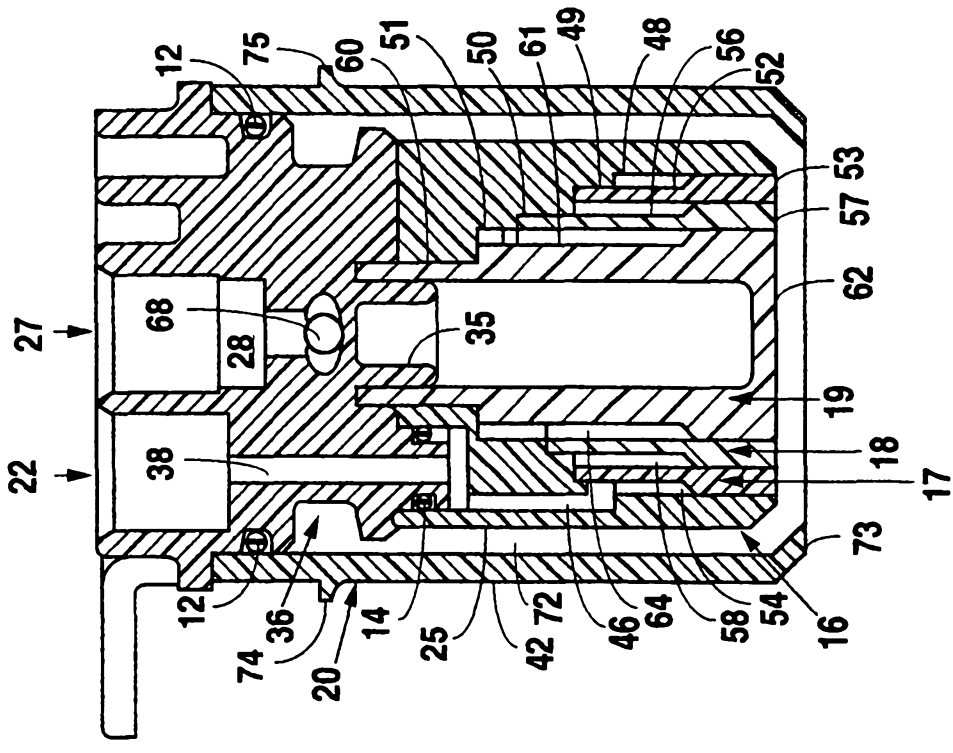

Fig. 8

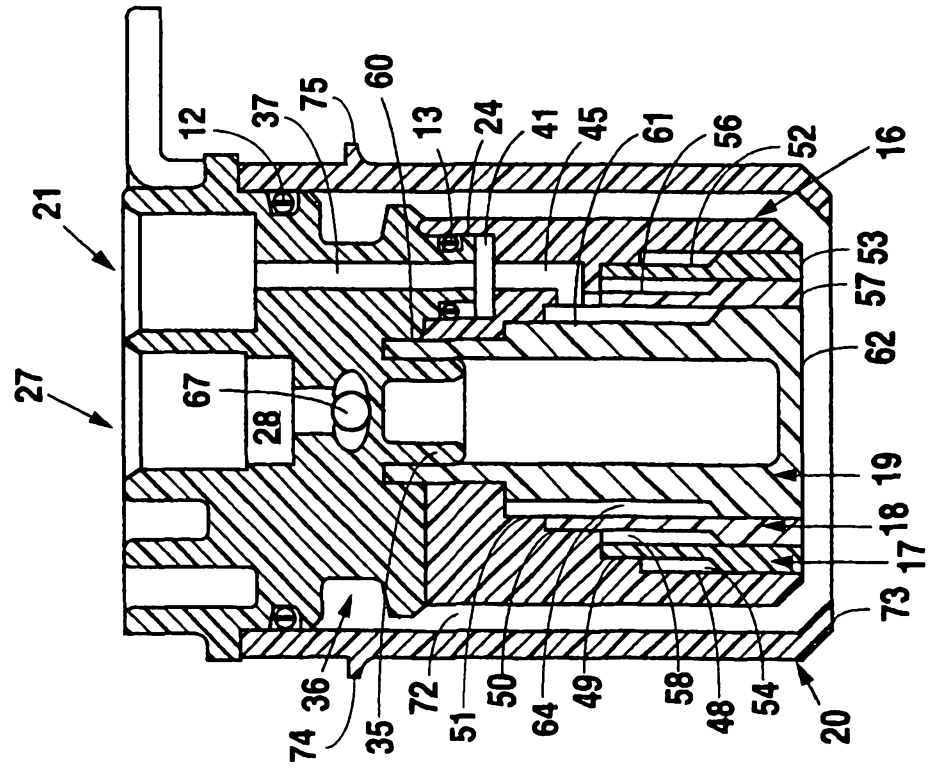

Fig. 7

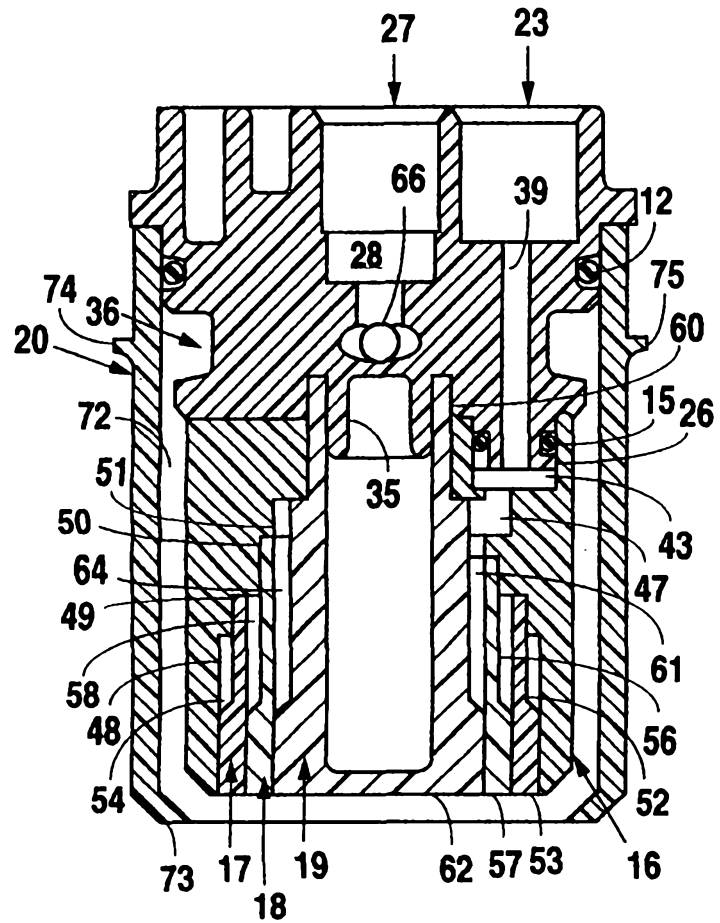

Fig. 9

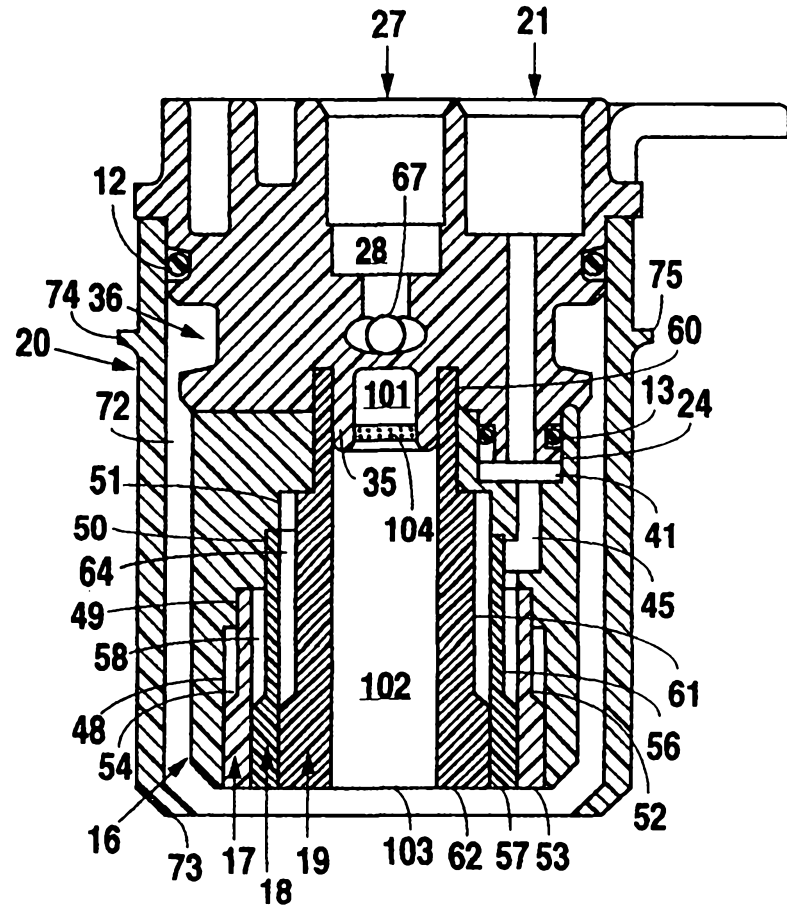

Fig. 10

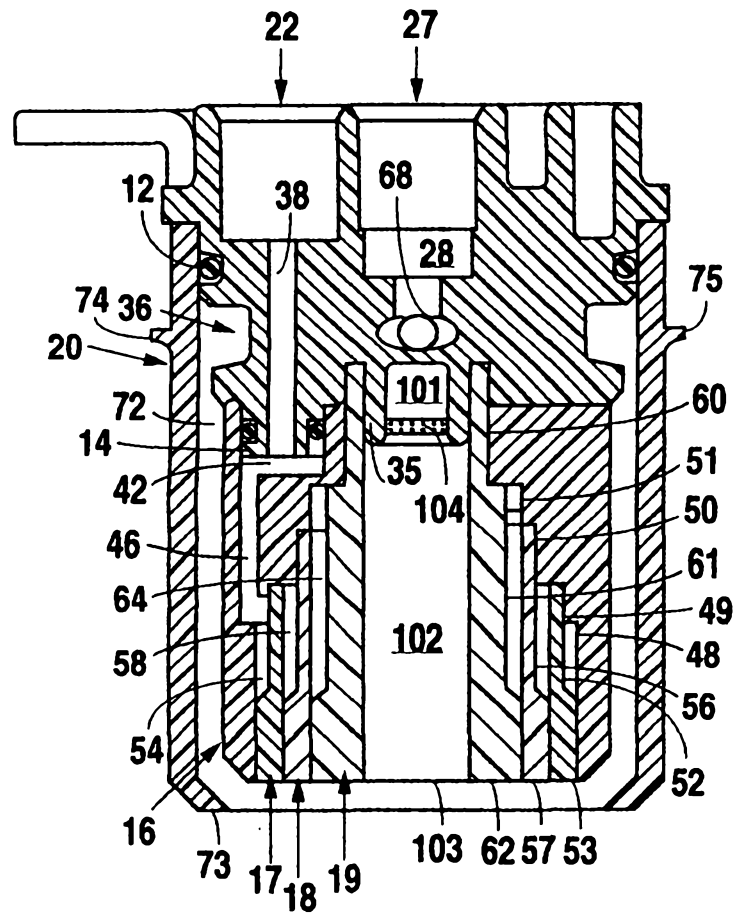

Fig. 11

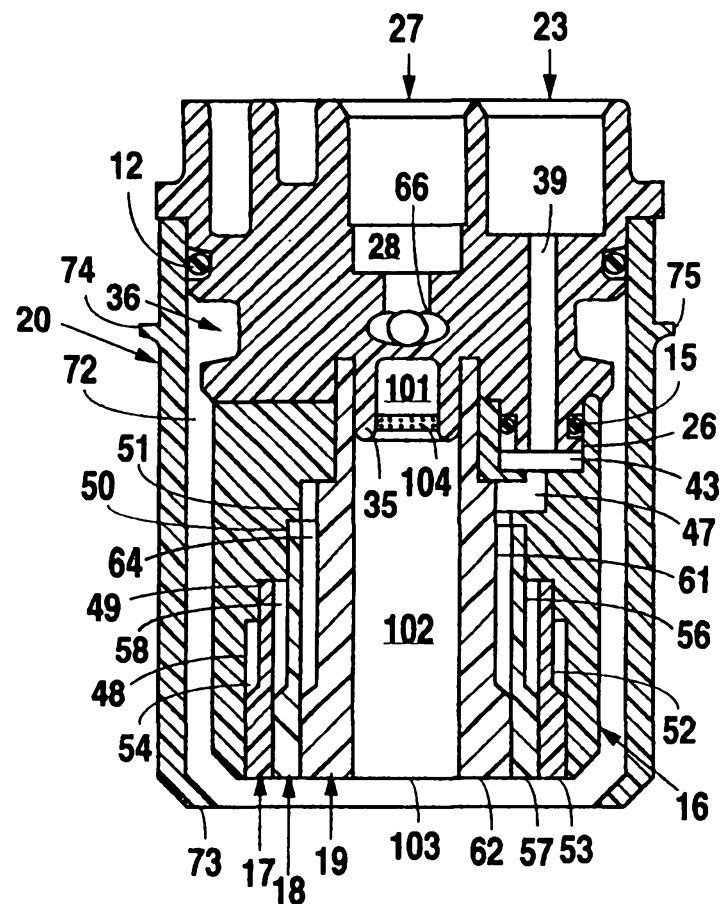

Fig. 12

8/15

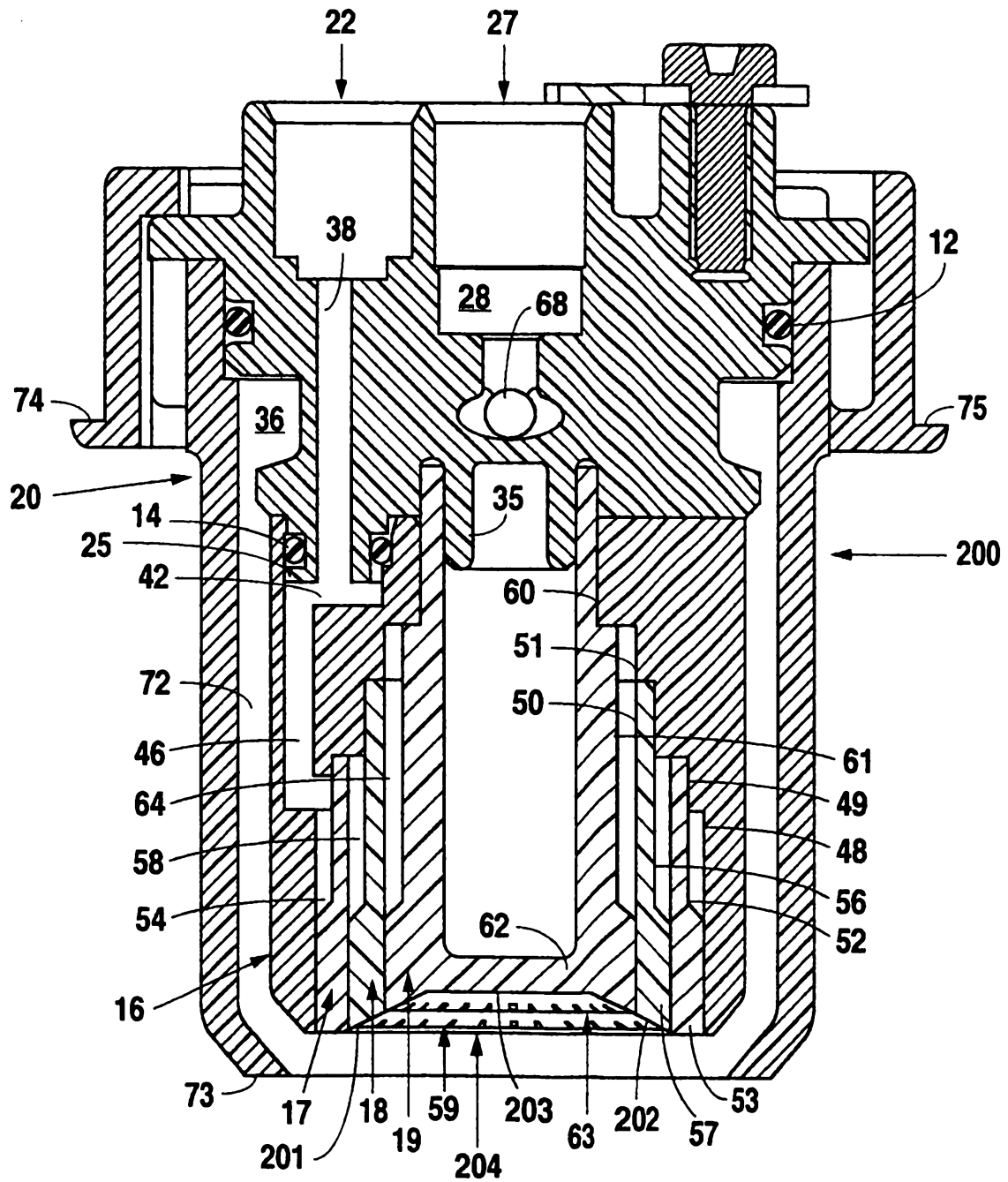

Fig 13

9/15

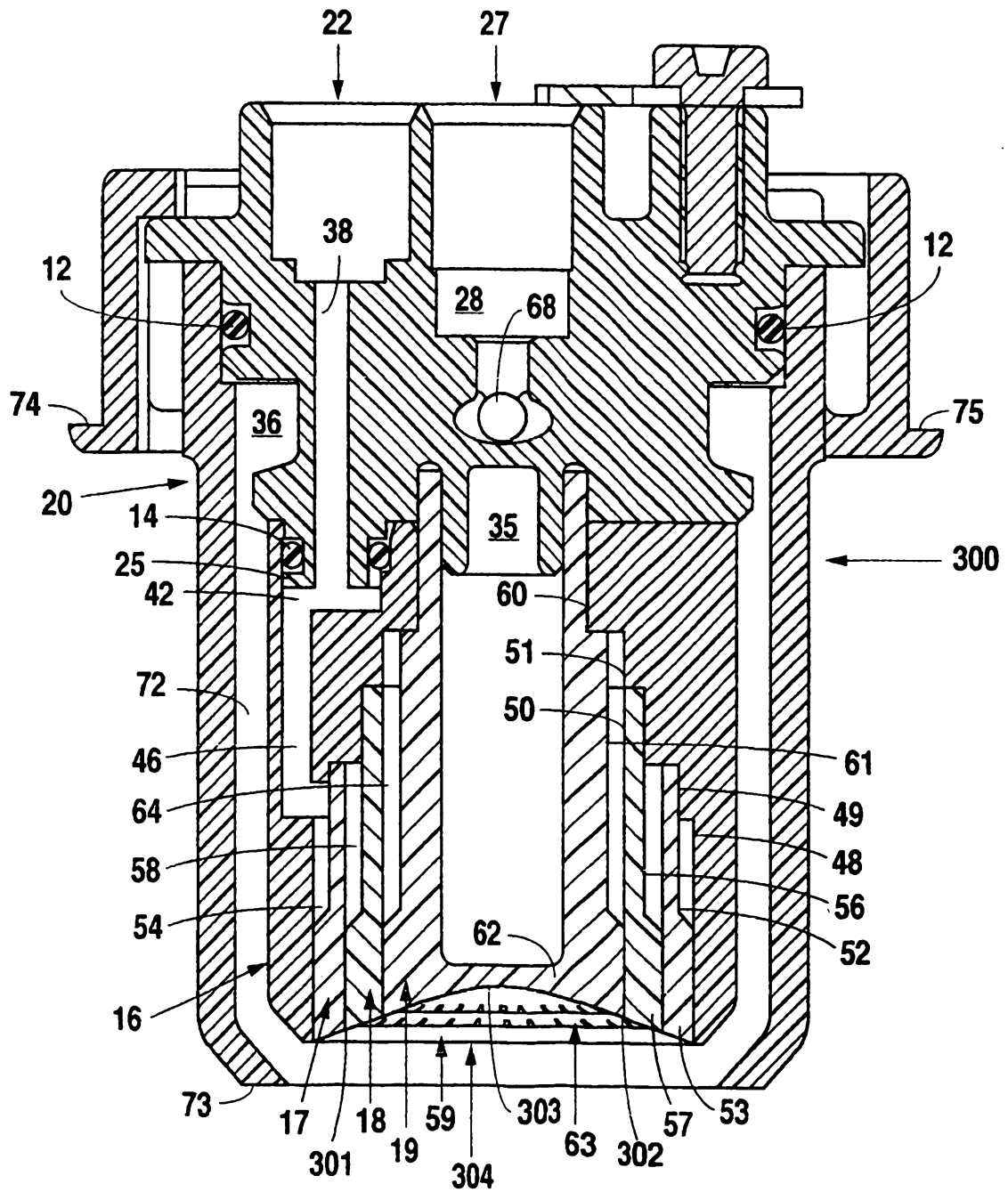

Fig. 14

10/15

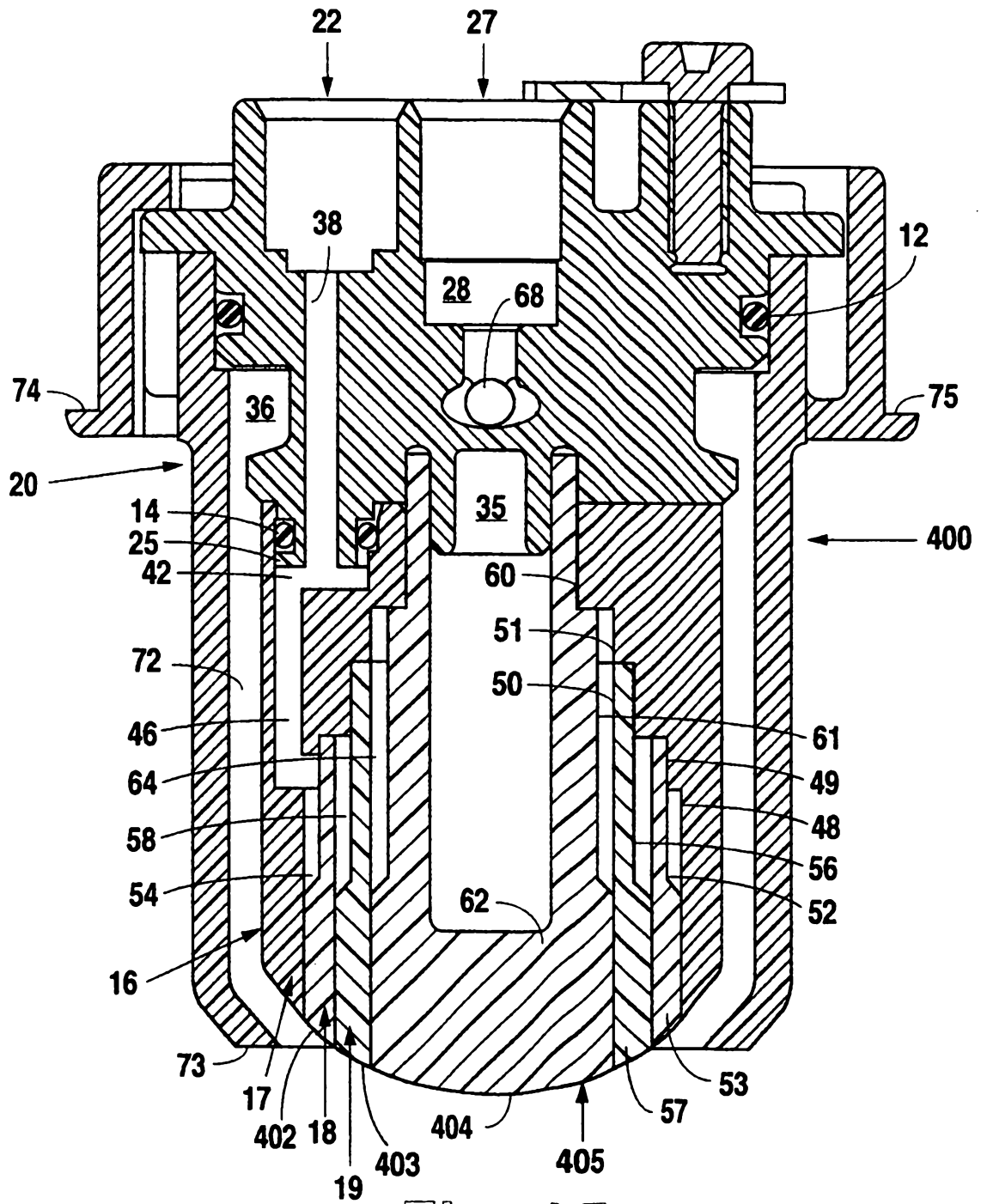

Fig. 15

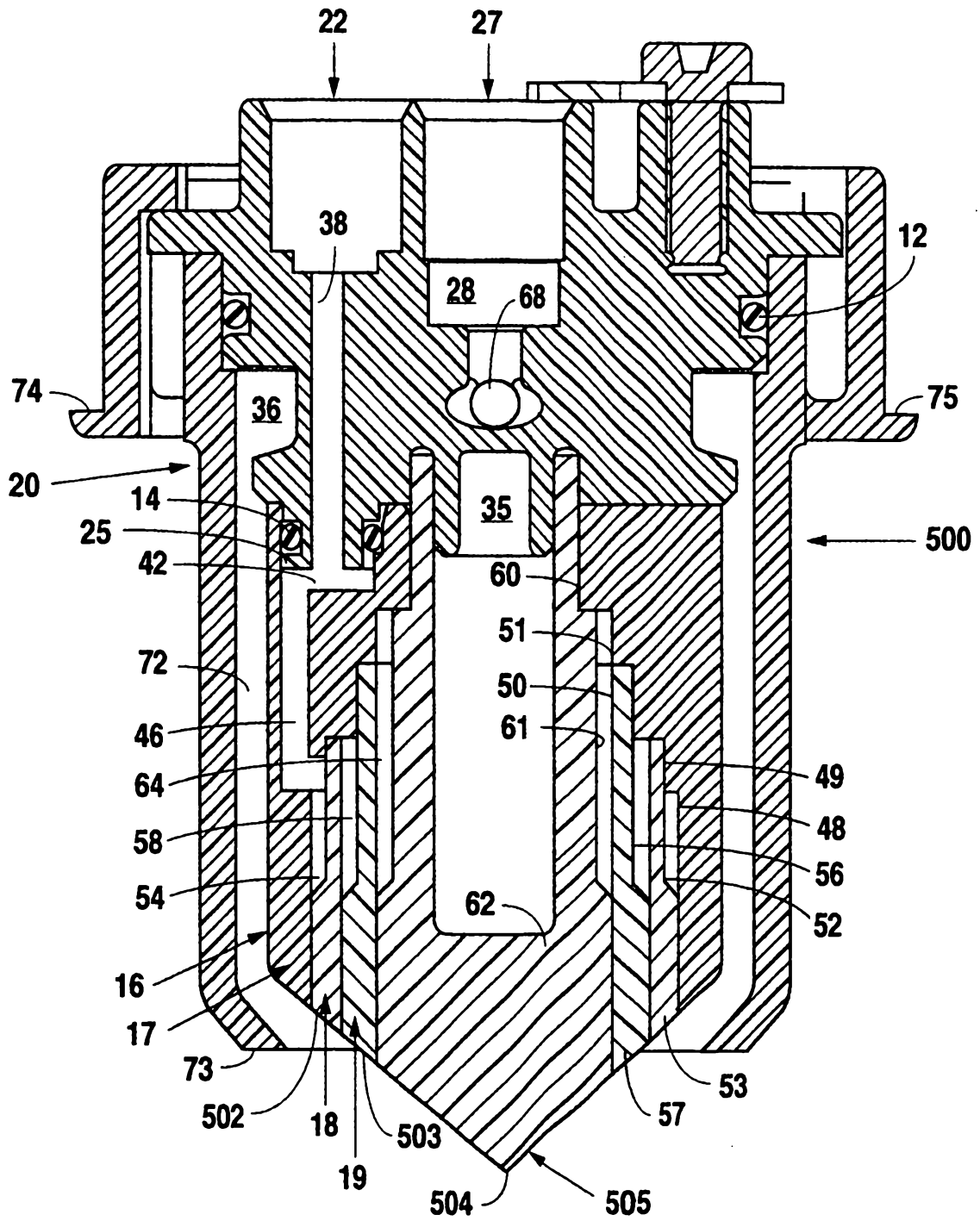

Fig. 16

12/15

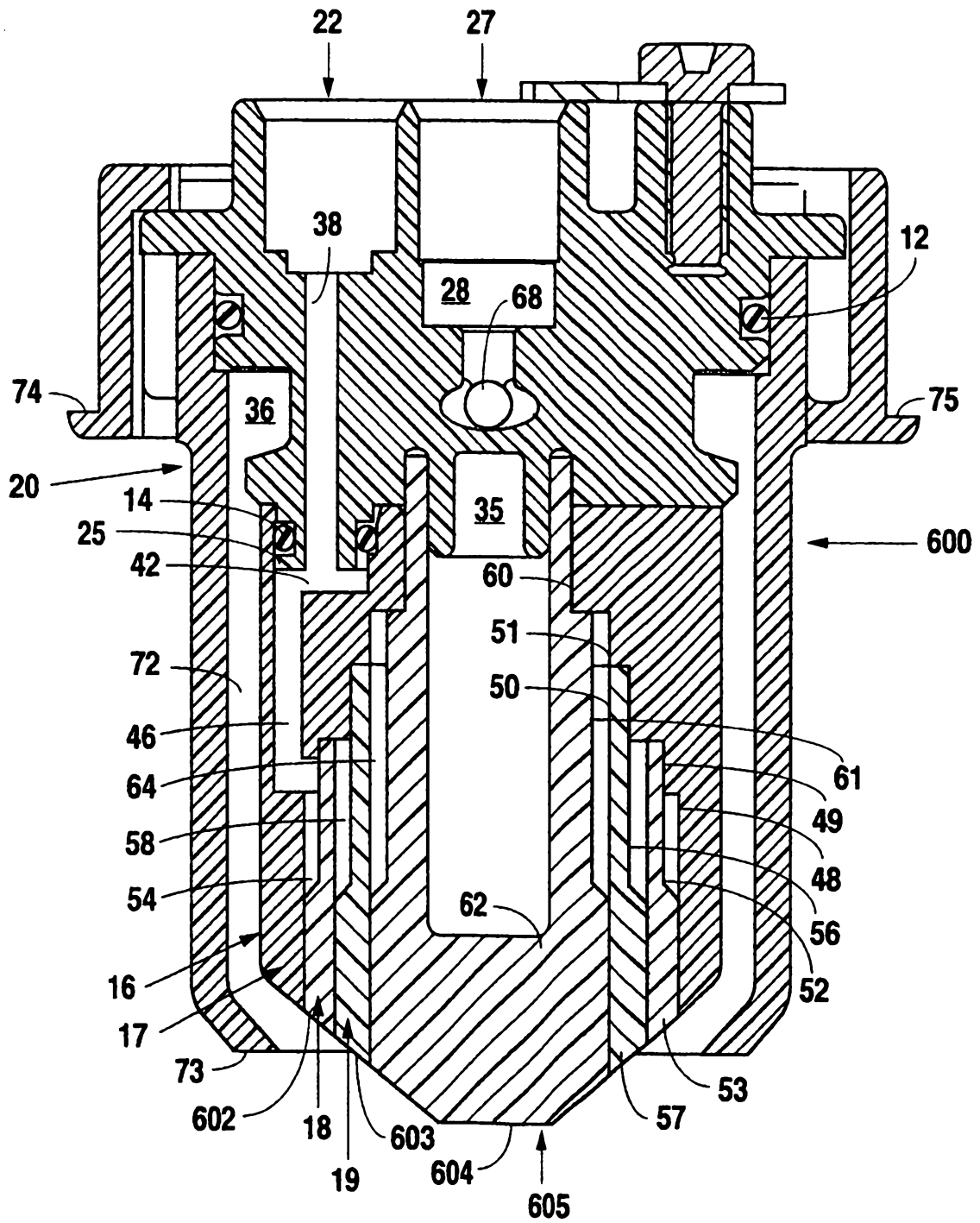

Fig. 17

13/15

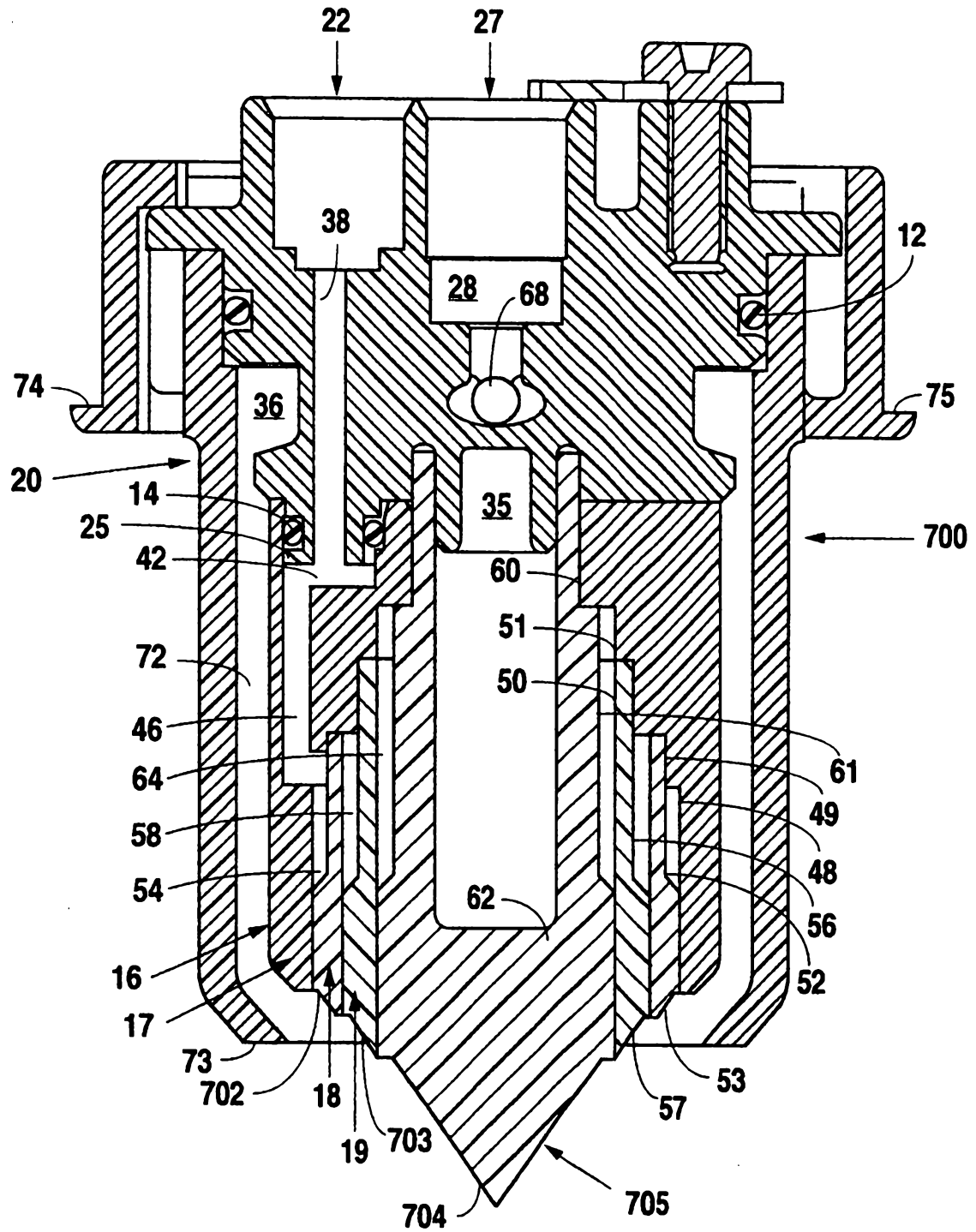

Fig. 18

14/15

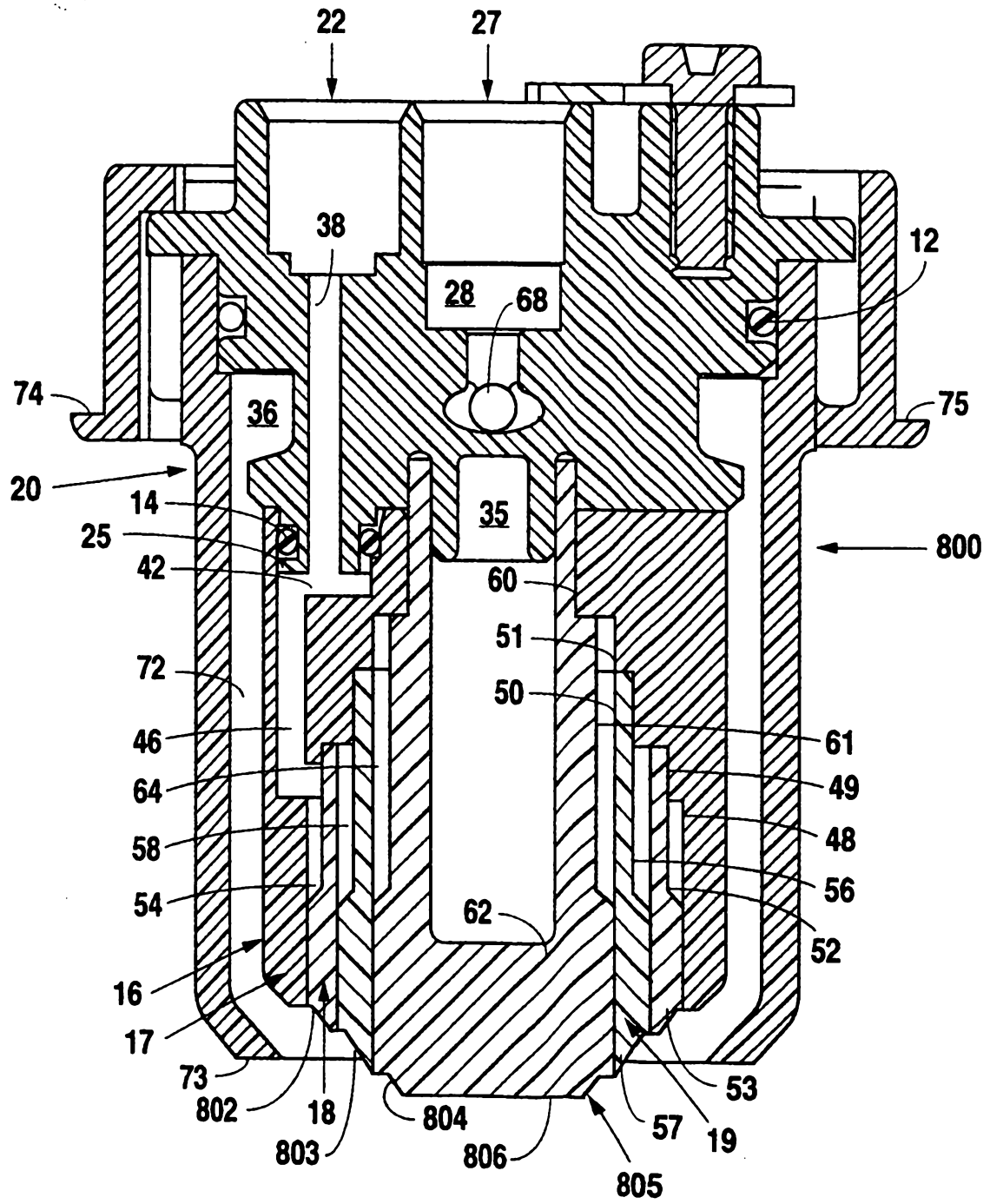

Fig. 19

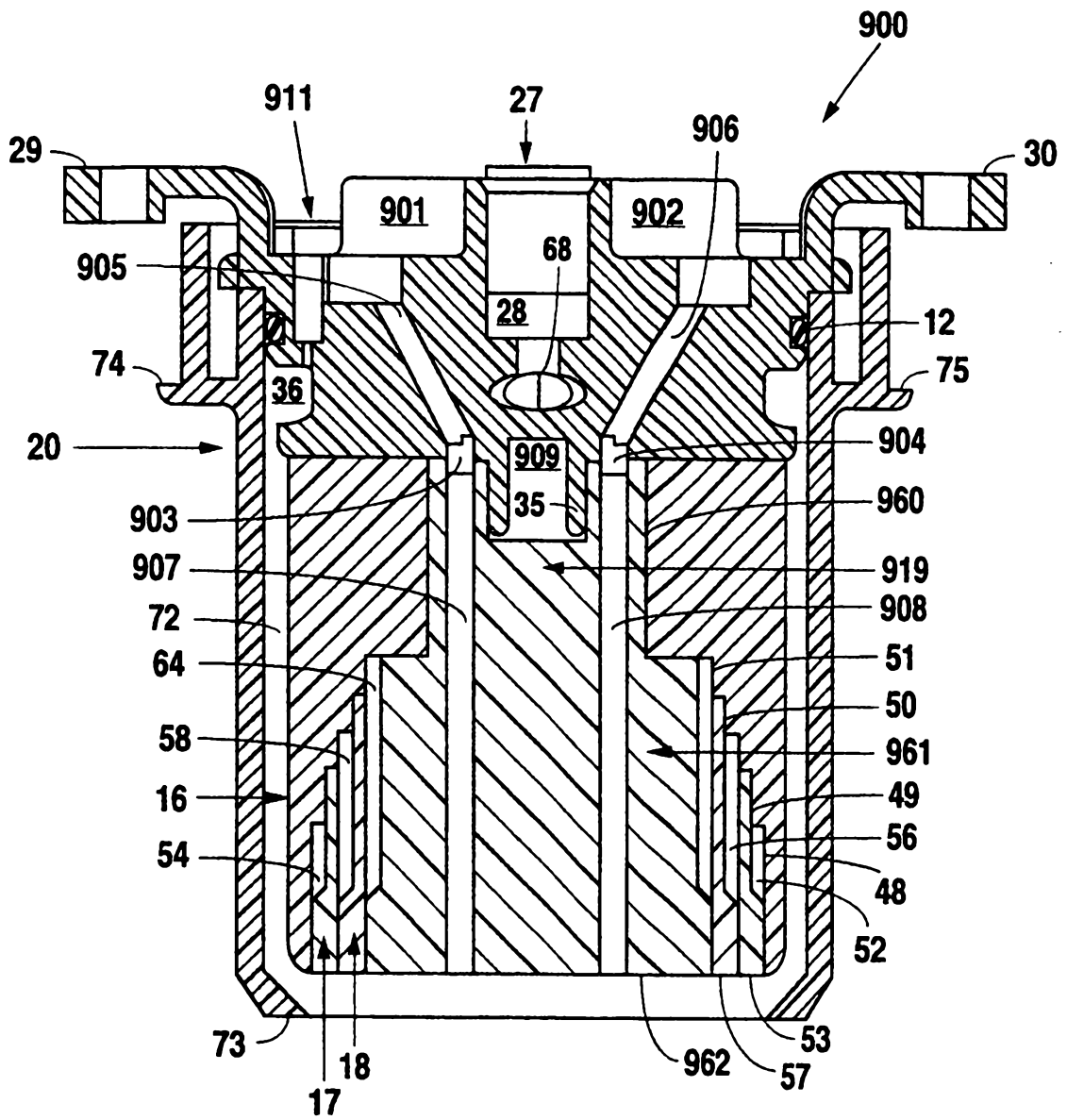

Fig. 20