

(12) **UK Patent Application** (19) **GB** (11) **2 341 646** (13) **A**

(43) Date of A Publication 22.03.2000

(21) Application No 9820332.6

(22) Date of Filing 19.09.1998

(71) Applicant(s)
Bernard John Sheridan
Woodland View, 9 Candleby Lane, COTGRAVE,
Nottingham, United Kingdom

(72) Inventor(s)
Bernard John Sheridan

(74) Agent and/or Address for Service
Urquhart-Dykes & Lord
Three Trinity Court, 21-27 Newport Road, CARDIFF,
CF24 0AA, United Kingdom

(51) INT CL⁷
F03D 9/00 3/02 3/04 , H02K 7/18

(52) UK CL (Edition R)
F1T TA TC T102 T121 T134 T149 T209 T301 T303 T311
T312
F1V VAA V112
U1S S1999

(56) Documents Cited
GB 2288642 A **GB 1593969 A** **GB 0492489 A**
US 5506453 A **US 4278896 A** **US 4061926 A**
US 4057270 A

(58) Field of Search
UK CL (Edition Q) F1T TA TC , F1V VAA
INT CL⁶ F03D 1/00 1/02 3/00 3/02 3/04 9/00
ONLINE:EPODOC,JAPIO,WPI

(54) Abstract Title
Wind powered electric generator

(57) A wind powered generator comprises a first part 10 mounted for rotation around an axis 12 and at least one other part 20 also mounted for rotation around the axis 12. An incoming flow of air C is directed against the vanes 11 of the first rotary part and against the vanes 21,31 of the other rotary parts 20, such that the first rotary part 10 and the other rotary parts 20 are driven in opposite directions of rotation. An electrical generator is coupled to the first rotary part 10 and the other rotary parts 20 to generate electric current in response to relative rotation between the first rotary part 10 and the other rotary parts 20. An armature of the generator may be disposed within a hollow interior of the first part 10 and be fixed to a shaft on which the other parts are mounted, field windings or a permanent magnet arrangement of the generator being carried by the first part.

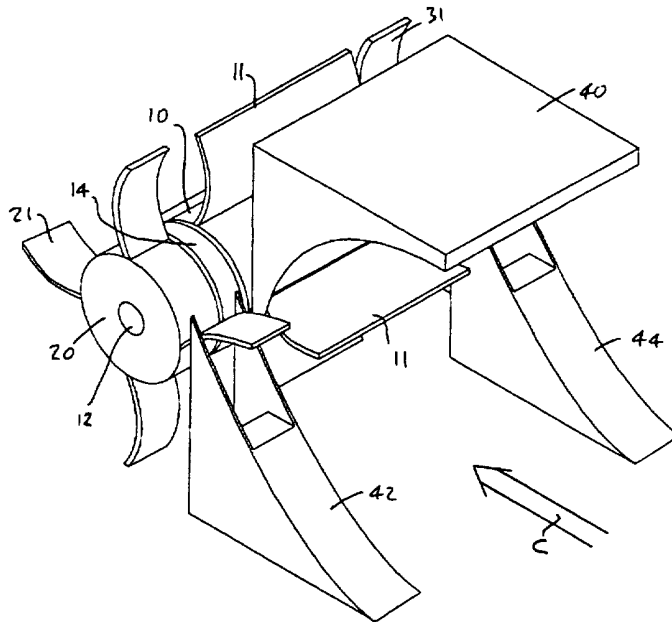

Figure 1

GB 2 341 646 A

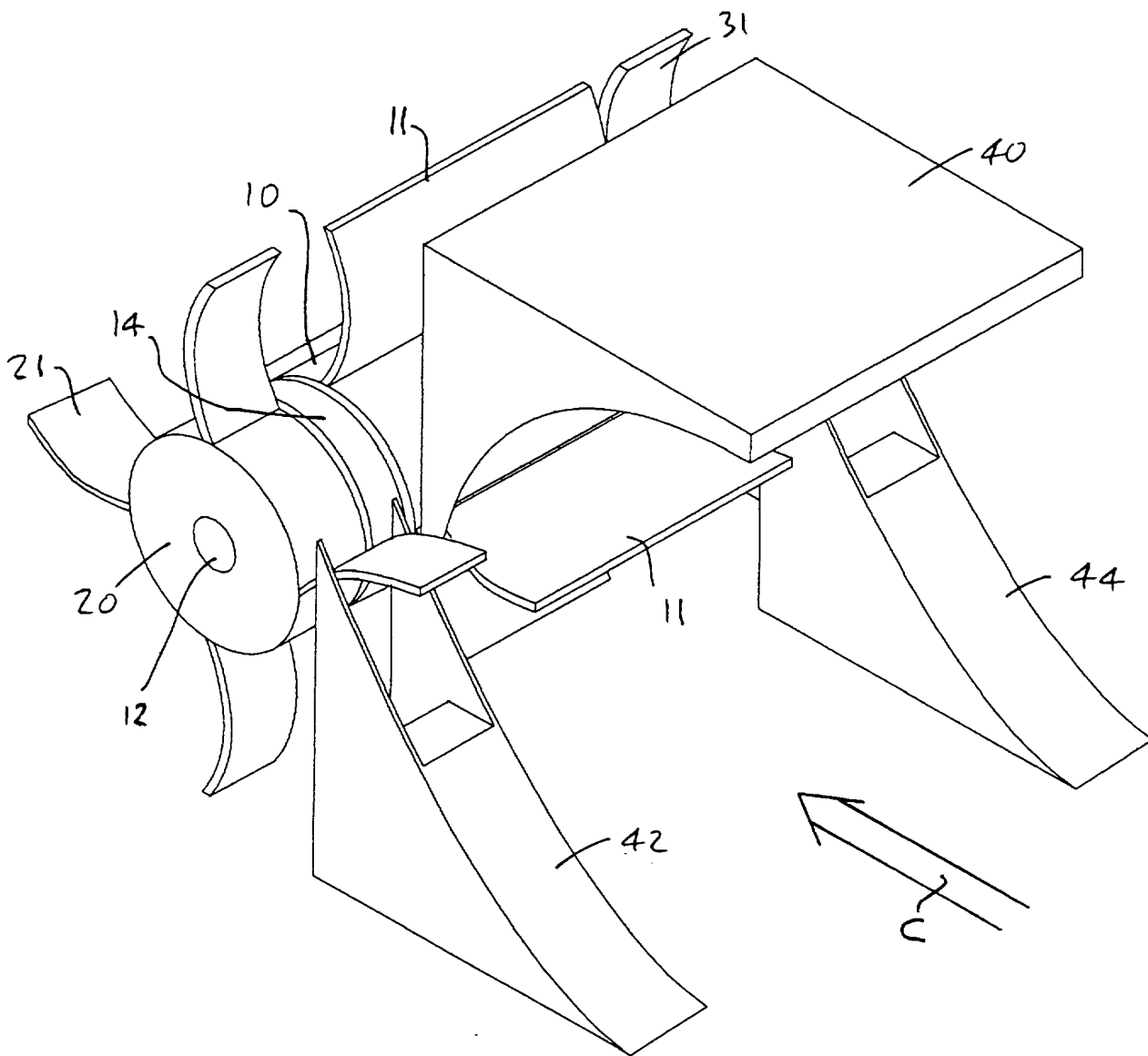

Figure 1

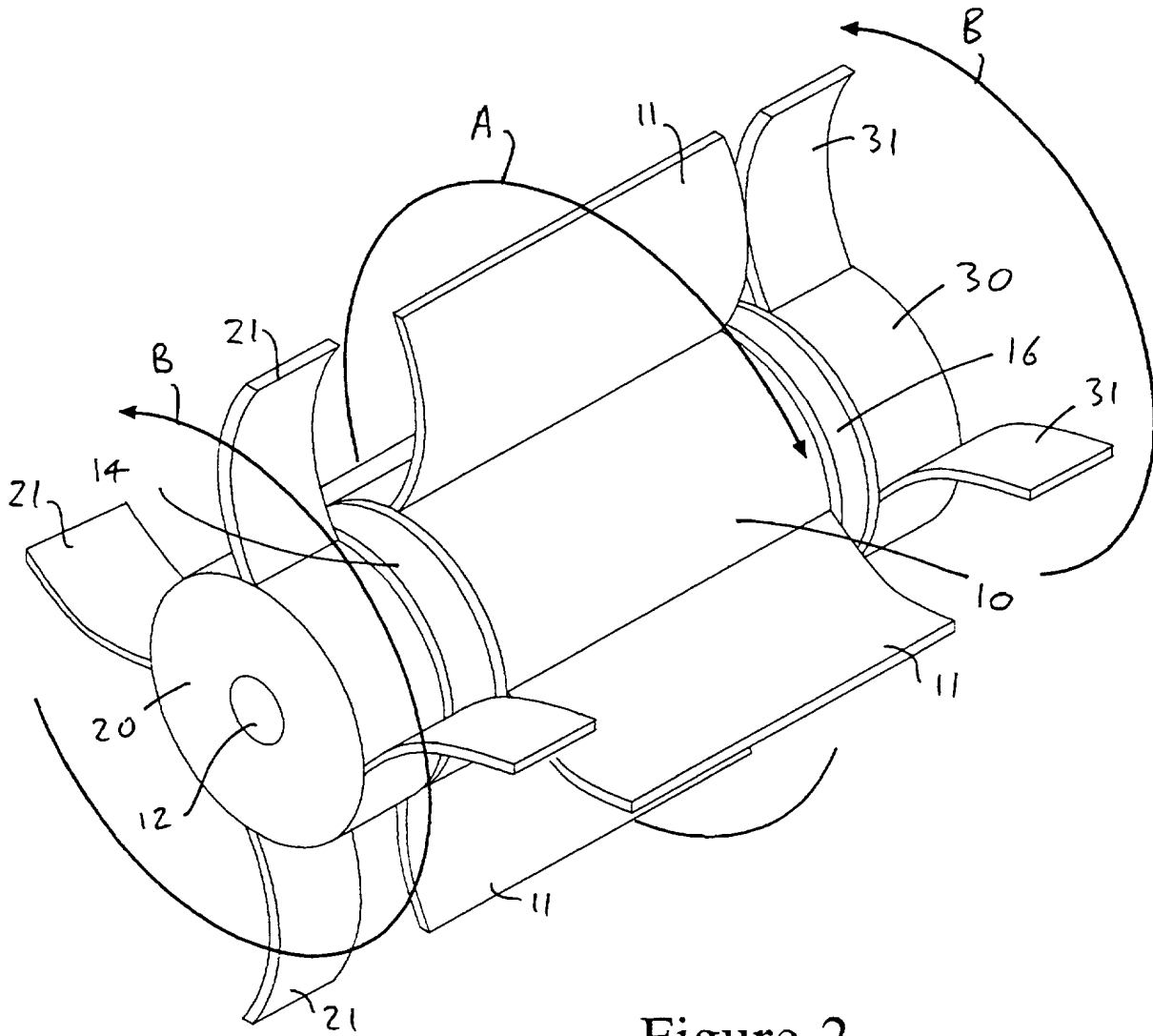

Figure 2

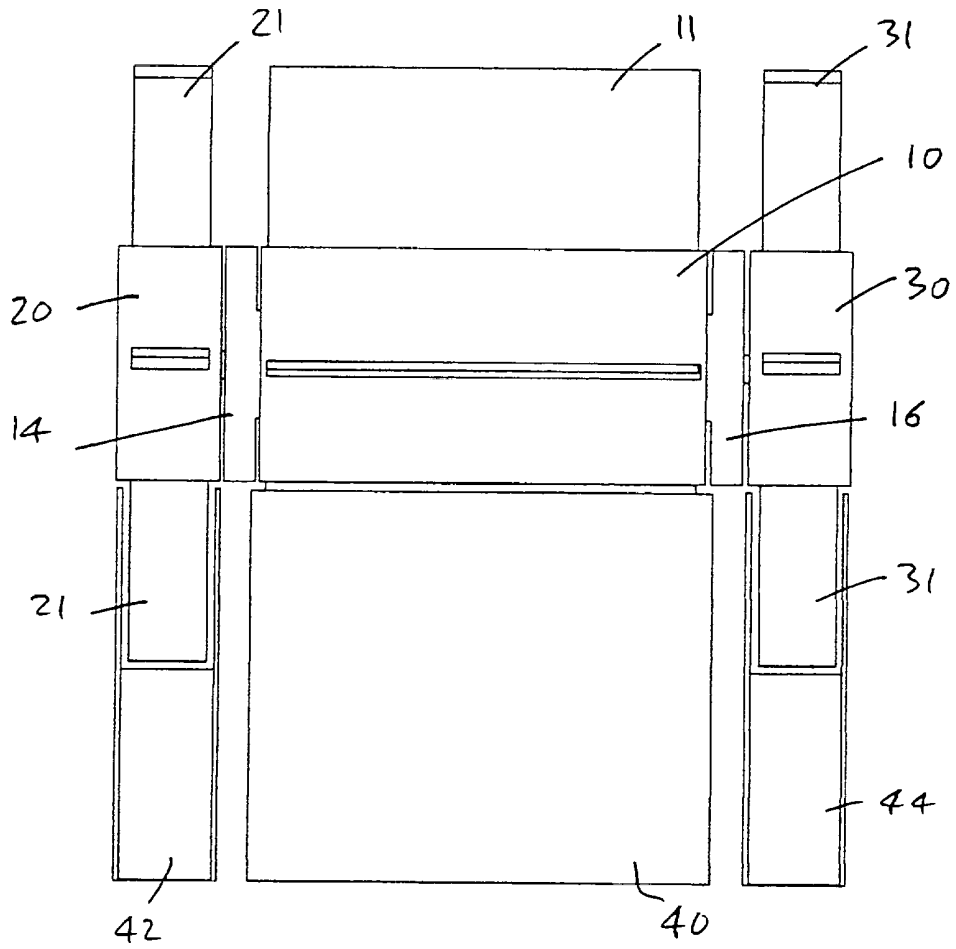

Figure 3

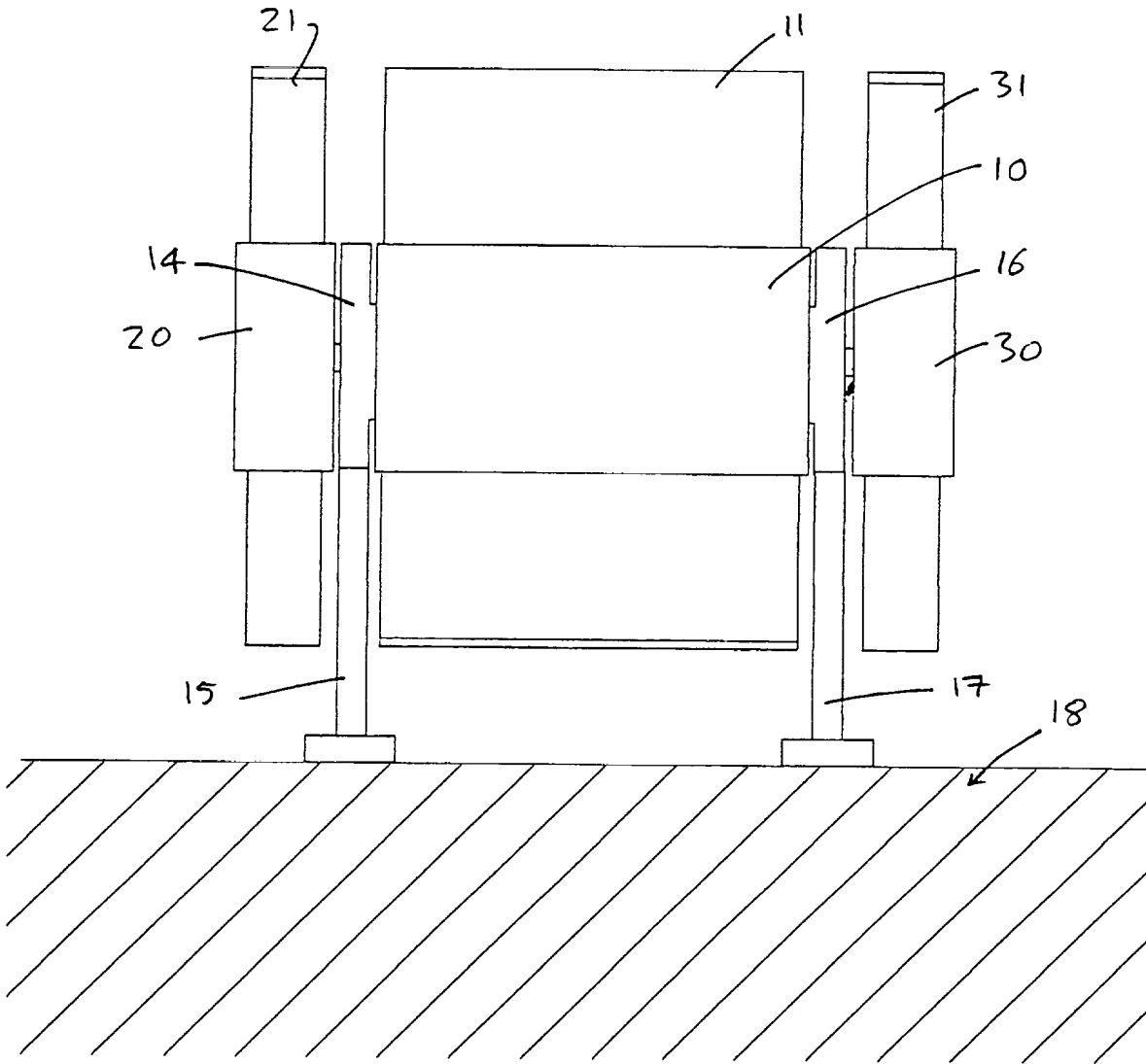

Figure 4

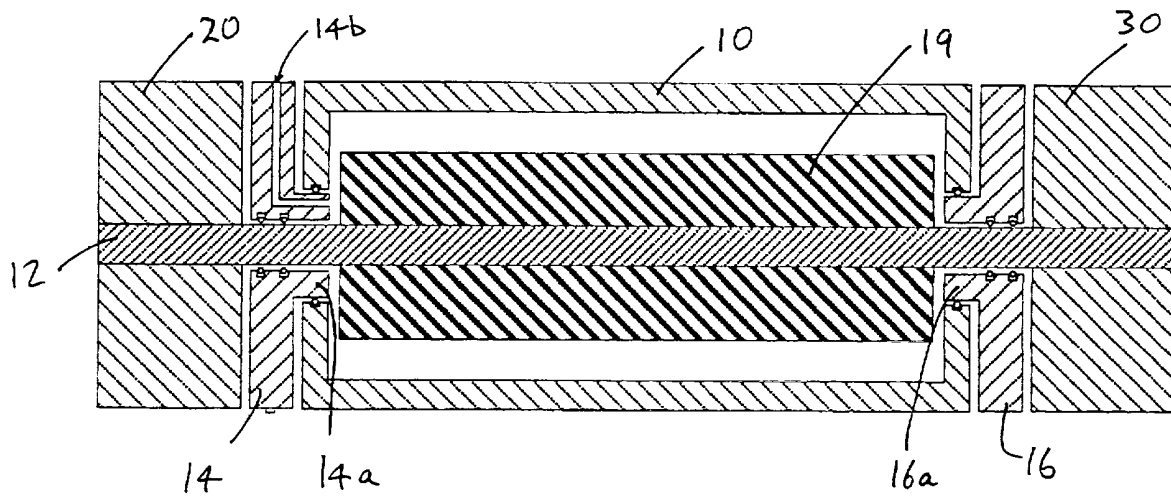

Figure 5

Wind Powered Generator

The present invention relates to a wind powered generator.

A number of different types of wind powered generators have been proposed hitherto. Each of these suffers from one or more limitations or disadvantages, particularly limited efficiency. I have now devised a wind powered generator which provides for improved efficiency.

In accordance with the present invention, there is provided a wind powered generator which comprises a first part which is mounted for rotation around an axis, at least one other part also mounted for rotation around said axis, means for directing a flow of air against vanes of the first rotary part and against vanes of the other rotary part or parts to drive the first rotary part and the or each other rotary part in opposite directions of rotation around said axis, and an electrical generator means coupled to the first rotary part and the other rotary part or parts and arranged to generate electric current in response to relative rotation of said first rotary part and the other rotary part or parts.

Prior art generators comprise a non-rotating part (or stator) co-operating with a rotating part (or rotor) to generate electric current: the rotating part includes an electrical armature which co-operates with field windings or permanent magnet assemblies on the stator. I have now appreciated that the efficiency of the generator is increased by providing that the two co-operating parts counter-rotate, thus increasing the speed of relative rotation and hence the current generated.

Preferably the generator comprises an armature positioned within a hollow interior of the first rotary part, and fixed to a shaft on which the other or auxiliary rotary part or parts are also fixed. The first rotary part is provided with field windings or permanent magnet assemblies in similar manner to the stator of a conventional generator, but is arranged to rotate (instead of being stationary) in the opposite direction to the armature.

Preferably the generator comprises two auxiliary rotary parts positioned adjacent the opposite ends of the first or main rotary part.

Preferably the armature shaft is journalled in bearings
5 provided in respective support plates adjacent the opposite ends of the main rotary part.

A deflector arrangement may be provided to separate an in-coming flow of air into different portions, one portion to impinge on the vanes of the main rotary part to drive this in
10 one direction of rotation, and the other portion or portions to impinge on the vanes of the other or auxiliary rotary part or parts to drive these in the opposite direction of rotation. Thus, a first deflector may be provided to one side of the rotary axis of the generator to direct the incoming air onto
15 the vanes of the first or main rotary part, and one or more other deflectors may be provided on the opposite side of the rotary axis of the generator, to direct the incoming air onto the vanes of the other or auxiliary rotary part or parts.

In an alternative arrangement, the in-coming air flow
20 may be channelled to impinge firstly against the vanes of one rotary part of the generator (to drive this part in one direction), then against the vanes of the second rotary part (to drive this in the opposite direction) before passing out through an air outlet of the generator.

25 An embodiment of the present invention will now be described by way of example only and with reference to the accompanying drawings, in which:

FIGURE 1 is a diagrammatic isometric view of a wind powered generator in accordance with the present invention;

30 FIGURE 2 is a isometric view of the rotary assemblies of the wind powered generator of Figure 1;

FIGURE 3 is a top plan view of the wind powered generator of Figure 1;

FIGURE 4 is a front end view of the wind powered
35 generator of Figure 1, shown with the deflector arrangements removed; and

FIGURE 5 is a diagrammatic longitudinal sectional view through the rotary assemblies of the wind powered generator.

Referring to the drawings, there is shown a wind

powered generator which comprises a main rotary part 10 and auxiliary rotary parts 20,30 disposed adjacent but outwardly of the opposite ends of the main rotary part 10. In the apparatus shown, the auxiliary rotary parts 20,30 are fixed to the opposite ends of a horizontal shaft 12 which extends axially through the main rotary part 10, as shown in Figure 5. The shaft 12 is journalled in bearings mounted in support plates 14,16 disposed between the opposite ends of the main rotary part 10 and the respective auxiliary rotary parts 20,30. The support plates 14,16 are mounted on respective uprights 15,17 fixed to a base 18, as shown in Figure 4.

The main rotary part 10 is generally cylindrical and hollow and is journalled at its opposite ends on bearings provided on inwardly-projecting bosses 14a,16a of the support plates 14,16. An electrical armature 19 is positioned within the main rotary part 10 and fixed to the shaft 12. The main rotary part 10 is provided, on its inner surface, with an arrangement of electrical windings or permanent magnets (not shown), arranged to co-operate with the armature 19, upon relative rotation between the main rotary part 10 and the auxiliary rotary parts 20,30, in the manner of the stator and rotor of a conventional generator, to generate electric current. Electric conductors (not shown) extend through a passage 14b in the support plate 14 into the interior of the part 10, where they are connected to slip rings or a commutator assembly, for coupling to the armature 19 and field windings (where provided) of the main rotary part 10.

As shown in Figures 1 to 4, the main rotary part 10 is provided with a series of outwardly-projecting, curved vanes 11 disposed at intervals around its outer surface. The auxiliary rotary parts 20,30 are provided with similar series of vanes 21,32 but curved in the opposite sense. The main rotary part 10 is thus arranged for rotation in the direction indicated by the arrow A in Figure 2, whilst the auxiliary rotary parts 20,30 are arranged for rotation in the opposite direction, indicated by the arrow B in Figure 2.

Referring to Figures 1 and 3, the generator which is shown is provided with deflector arrangements to ensure that a flow of air, incident on the generator is the direction of

the arrow C, will impinge on the vanes of the main rotary part 10 to drive it in its required direction and will impinge on the vanes of the auxiliary rotary parts to drive them in their required direction, opposite to the direction of rotation of the main rotary body 10. Thus, the deflector arrangements comprise a first deflector 40 mounted across the main rotary part 10, mainly above the level of its axis of rotation, the deflector 40 having a downwardly-curved deflector surface to direct the air flow downwardly onto the vanes 11 of the rotary part 10. Further, the deflector arrangements comprise second and third deflectors 42,44 mounted across the auxiliary rotary parts 20,30 mainly below the level of their axis of rotation, the deflectors 42,44 having upwardly-curved deflector surfaces to direct the air flow upwardly onto the vanes 21,31 of the rotary parts 20,30.

Air flow arrangements of different form may be provided instead. For example, the air may be caused to flow against the vanes of the main rotary part 10 (to drive this part) then subsequently to flow against the auxiliary rotary parts 20 and 30 (to drive these parts) before finally passing out through an air outlet of the generator.

It will be appreciated that, in use, the efficiency of the generator is improved, relative to generators having co-operating rotating and non-rotating parts (rotor and stator), because both co-operating parts of the generator counter-rotate.

Preferably the wind powered generator is positioned, together with a number of similar generators, in a natural wind channel such as a valley.

Claims

1) A wind powered generator, comprising a first part which is mounted for rotation around an axis, at least on other part also mounted for rotation around said axis, means for directing
5 a flow of air against vanes of the first rotary part and against vanes of the other rotary part or parts to drive the first rotary part and the or each other rotary part in opposite directions of rotation around said axis, and an electrical generator means coupled to the first rotary part and the other
10 rotary part or parts and arranged to generate electric current in response to relative rotation between said first rotary part and the other rotary part or parts.

2) A wind powered generator as claimed in claim 1, in which said generator means comprises an armature carried by one
15 said rotary part and field windings or a permanent magnet arrangement carried by a contra-rotating said rotary part.

3) A wind powered generator as claimed in claim 2, in which said armature is disposed within a hollow interior of
20 said first rotary part and is fixed to a shaft on which said other rotary part or parts are also fixed, said field windings or permanent magnet arrangement being carried by said first rotary part.

4) A wind powered generator as claimed in claim 3, comprising said first rotary part and two other said rotary
25 parts, which are positioned adjacent the opposite ends of said first rotary part.

5) A wind powered generator as claimed in claim 3 or 4, in which said shaft is journalled in bearings provided in
30 respective support plates disposed adjacent the opposite ends of said first rotary part.

6) A wind powered generator as claimed in any preceding claim, in which said flow-directly means comprises a deflector arrangement for separating an incoming flow of air into

different portions, one portion to impinge on the vanes of said first rotary part and the other portion or portions to impinge on the vanes of said other rotary part or parts.

7) A wind powered generator as claimed in claim 6, in which said deflector arrangement comprises a first deflector positioned to one side of said rotary axis to direct said one portion of the incoming air onto the vanes of said first rotary part, and one or more further deflectors positioned to the opposite side of said rotary axis to direct said other portion or portions of the incoming air onto the vanes of said other rotary part or parts.

8) A wind powered generator as claimed in any one of claim 1 to 5, in which said flow-directing means is arranged to channel the incoming air flow to impinge firstly against the vanes of one said rotary part to drive this one part in one rotary direction, then against the vanes of a second said rotary part to drive this second part in the opposite rotary direction.

9) A wind powered generator substantially as herein described with reference to the accompanying drawings.



Application No: GB 9820332.6
Claims searched: 1-9

Examiner: C B VOSPER
Date of search: 27 August 1999

Patents Act 1977
Search Report under Section 17

Databases searched:

UK Patent Office collections, including GB, EP, WO & US patent specifications, in:

UK CI (Ed.Q): F1T(TA,TC); F1V(VAA)

Int CI (Ed.6): F03D 1/00,1/02,3/00,3/02,3/04,9/00

Other: ONLINE:EPODOC,JAPIO,WPI

Documents considered to be relevant:

Category	Identity of document and relevant passage	Relevant to claims
X	GB 2288642 A BURNS (fig. 5; page 7, lines 1-13)(Equivalent = US5760515)	1,2
X	GB 1593969 TRIMBLES (whole document)	1,2
Y	GB 0492489 LEAN (figs. 2 and 3)	4
X	US 5506453 MCCOMBS (fig. 2; col. 11-col.12, claim 1; col.6, line 53 - col. 7, line 7)	1,2
Y	US 4278896 MCFARLAND (fig. 1)	4
X	US 4061926 PEED (whole document)	1,2
X:Y	US 4057270 LEBOST (whole document)	1-3,6 : 4

X Document indicating lack of novelty or inventive step
Y Document indicating lack of inventive step if combined with one or more other documents of same category.

& Member of the same patent family

A Document indicating technological background and/or state of the art.
P Document published on or after the declared priority date but before the filing date of this invention.

E Patent document published on or after, but with priority date earlier than, the filing date of this application.