



## INTERNATIONAL APPLICATION PUBLISHED UNDER THE PATENT COOPERATION TREATY (PCT)

<p>(51) International Patent Classification<sup>6</sup> : A61M 16/06, A62B 18/08, A41D 13/00</p>	A1	<p>(11) International Publication Number: <b>WO 99/25410</b></p> <p>(43) International Publication Date: 27 May 1999 (27.05.99)</p>
<p>(21) International Application Number: PCT/IE98/00094</p> <p>(22) International Filing Date: 16 November 1998 (16.11.98)</p> <p>(30) Priority Data: S970808 14 November 1997 (14.11.97) IE</p> <p>(71) Applicant (for all designated States except US): MEDISOLVE LIMITED [IE/IE]; Suite 3, Blackrock Clinic, Rock Road, Blackrock, County Dublin (IE).</p> <p>(71)(72) Applicant and Inventor: CROWE, Louis, Michael [IE/IE]; 65 Beech Park Road, Dublin 18 (IE).</p> <p>(74) Agent: F.F. GORMAN &amp; CO.; 54 Merrion Square, Dublin 2 (IE).</p>		<p>(81) Designated States: AL, AM, AT, AU, AZ, BA, BB, BG, BR, BY, CA, CH, CN, CU, CZ, DE, DK, EE, ES, FI, GB, GE, GH, GM, HR, HU, ID, IL, IS, JP, KE, KG, KP, KR, KZ, LC, LK, LR, LS, LT, LU, LV, MD, MG, MK, MN, MW, MX, NO, NZ, PL, PT, RO, RU, SD, SE, SG, SI, SK, SL, TJ, TM, TR, TT, UA, UG, US, UZ, VN, YU, ZW, ARIPO patent (GH, GM, KE, LS, MW, SD, SZ, UG, ZW), Eurasian patent (AM, AZ, BY, KG, KZ, MD, RU, TJ, TM), European patent (AT, BE, CH, CY, DE, DK, ES, FI, FR, GB, GR, IE, IT, LU, MC, NL, PT, SE), OAPI patent (BF, BJ, CF, CG, CI, CM, GA, GN, GW, ML, MR, NE, SN, TD, TG).</p> <p><b>Published</b> With international search report. Before the expiration of the time limit for amending the claims and to be republished in the event of the receipt of amendments.</p>

(54) Title: A SEAL FOR A RESPIRATORY MASK, AND A RESPIRATORY MASK

## (57) Abstract

A seal for sealing a respiratory mask (1, 20, 30, 40) to the face (2) of a subject, the seal comprising a peripheral sealing means (11, 21, 31, 41) for extending around a face engaging periphery (8) of the mask (1), and an adhesive means (11, 21, 31, 41) for sealably adhering the peripheral sealing means (11, 21, 31, 41) to the face of the subject for minimising leakage from the respiratory mask (1, 20, 30, 40) between the face engaging periphery (8) of the mask (1, 20, 30, 40) and the face of the subject.

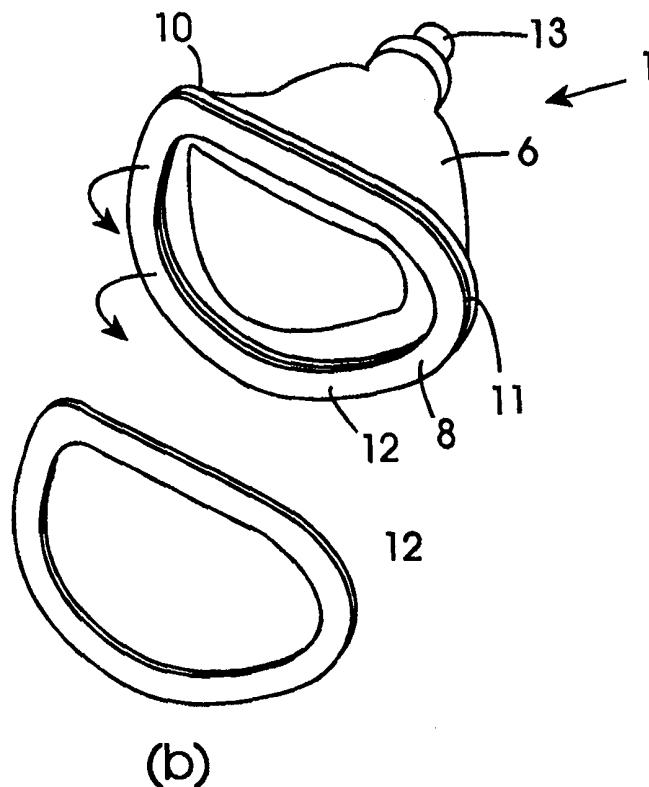

**FOR THE PURPOSES OF INFORMATION ONLY**

Codes used to identify States party to the PCT on the front pages of pamphlets publishing international applications under the PCT.

<b>AL</b>	Albania	<b>ES</b>	Spain	<b>LS</b>	Lesotho	<b>SI</b>	Slovenia
<b>AM</b>	Armenia	<b>FI</b>	Finland	<b>LT</b>	Lithuania	<b>SK</b>	Slovakia
<b>AT</b>	Austria	<b>FR</b>	France	<b>LU</b>	Luxembourg	<b>SN</b>	Senegal
<b>AU</b>	Australia	<b>GA</b>	Gabon	<b>LV</b>	Latvia	<b>SZ</b>	Swaziland
<b>AZ</b>	Azerbaijan	<b>GB</b>	United Kingdom	<b>MC</b>	Monaco	<b>TD</b>	Chad
<b>BA</b>	Bosnia and Herzegovina	<b>GE</b>	Georgia	<b>MD</b>	Republic of Moldova	<b>TG</b>	Togo
<b>BB</b>	Barbados	<b>GH</b>	Ghana	<b>MG</b>	Madagascar	<b>TJ</b>	Tajikistan
<b>BE</b>	Belgium	<b>GN</b>	Guinea	<b>MK</b>	The former Yugoslav Republic of Macedonia	<b>TM</b>	Turkmenistan
<b>BF</b>	Burkina Faso	<b>GR</b>	Greece	<b>ML</b>	Mali	<b>TR</b>	Turkey
<b>BG</b>	Bulgaria	<b>HU</b>	Hungary	<b>MN</b>	Mongolia	<b>TT</b>	Trinidad and Tobago
<b>BJ</b>	Benin	<b>IE</b>	Ireland	<b>MR</b>	Mauritania	<b>UA</b>	Ukraine
<b>BR</b>	Brazil	<b>IL</b>	Israel	<b>MW</b>	Malawi	<b>UG</b>	Uganda
<b>BY</b>	Belarus	<b>IS</b>	Iceland	<b>MX</b>	Mexico	<b>US</b>	United States of America
<b>CA</b>	Canada	<b>IT</b>	Italy	<b>NE</b>	Niger	<b>UZ</b>	Uzbekistan
<b>CF</b>	Central African Republic	<b>JP</b>	Japan	<b>NL</b>	Netherlands	<b>VN</b>	Viet Nam
<b>CG</b>	Congo	<b>KE</b>	Kenya	<b>NO</b>	Norway	<b>YU</b>	Yugoslavia
<b>CH</b>	Switzerland	<b>KG</b>	Kyrgyzstan	<b>NZ</b>	New Zealand	<b>ZW</b>	Zimbabwe
<b>CI</b>	Côte d'Ivoire	<b>KP</b>	Democratic People's Republic of Korea	<b>PL</b>	Poland		
<b>CM</b>	Cameroon	<b>KR</b>	Republic of Korea	<b>PT</b>	Portugal		
<b>CN</b>	China	<b>KZ</b>	Kazakstan	<b>RO</b>	Romania		
<b>CU</b>	Cuba	<b>LC</b>	Saint Lucia	<b>RU</b>	Russian Federation		
<b>CZ</b>	Czech Republic	<b>LI</b>	Liechtenstein	<b>SD</b>	Sudan		
<b>DE</b>	Germany	<b>LK</b>	Sri Lanka	<b>SE</b>	Sweden		
<b>DK</b>	Denmark	<b>LR</b>	Liberia	<b>SG</b>	Singapore		
<b>EE</b>	Estonia						

"A seal for a respiratory mask,  
and a respiratory mask"

The present invention relates to a seal for sealing a respiratory mask to the face of a subject and to a respiratory mask comprising the seal. The invention also relates to a method for minimising leakage from a respiratory mask.

Respiratory masks exist in many forms such as ventilation masks for ventilating a patient or a subject, diving masks, surgical masks, dust masks and breathing masks used by firefighters and the like. Some masks are held in position by force applied on the mask by a hand or hands while some are held in position by a band, cord or the like and some by a combination of the two methods. However, it is usually desirable or indeed essential for such masks to enjoy a sealing relationship with the facial contours of a subject in order to minimise leakage from the respiratory mask or ingress of external fluids such as gases or water into the mask. In addition, externally applied pressure and/or bands do not usually securely hold masks in place. Moreover, due to variations in facial contours between subjects, effective sealing relationships between respiratory masks and a subject are difficult to achieve.

For example, in some applications, to obtain sealing, it is known to press a respiratory mask tightly against the face in order to achieve effective engagement and sealing with the face. Such practice can be extremely uncomfortable for the subject, particularly over prolonged periods, while in some applications can also cause damage to the facial tissues.

Ventilation masks are used for ventilating a subject during, for example, a cardiac arrest or during general anaesthesia. Air or oxygen is delivered through the ventilation mask to the lungs of the subjects. Typically, ventilation masks comprise a canopy-like structure which when placed on the face of the subject covers the

mouth and nose of the subject. The canopy-like structure usually terminates in a face engaging periphery which engages the face of the subject adjacent the bridge of the nose, the cheeks of the subject adjacent the nose, around the opposite sides of the mouth, and beneath the mouth, or below the chin. One or more inlets are provided to the canopy for facilitating ventilation of the subject either by delivery of oxygen to the subject, or by an individual exhaling into one of the openings for ventilating the subject. In order to minimise leakage of oxygen or air from the canopy between the face engaging periphery and the subject's face a pneumatic cushion may be provided around the face engaging periphery. The pneumatic cushion comprises a tubular member which extends around the face engaging periphery and is air filled to the extent that some deformation of the tubular member is permitted for accommodating the contours of the subject's face.

However, while leakage from such ventilation masks may be minimised by holding the mask firmly against the face of the subject with the pneumatic cushion pressed firmly against the subject's face, in many instances, it is virtually impossible to adequately seal the mask to the subject's face. This leads to leakage of the air or oxygen from the mask. Since the air or oxygen will take the line of least resistance, unless the mask is firmly held against the subject's face much of the air and oxygen leaks from the mask, and thus, adequate ventilation of the subject's lungs is unachievable and brain damage and other serious complications can result.

In many instances, it is not feasible for a doctor or a nurse who is resuscitating a subject to hold the ventilation mask sufficiently firmly against the subject's face to avoid such leakage. Where ventilation is being carried out by a pump, the doctor's or nurse's hands may be fully occupied in operating and manipulating the pump, and therefore holding the ventilation mask firmly against the face of the subject is very difficult.

Ventilation masks are also widely used in Continuous Positive Airway Pressure (CPAP) treatment in which pressure is applied to the lungs of a subject in order to prevent alveolar collapse. In order to apply the pressure to the lungs, it will be appreciated that sealing between the mask and the face of a patient is essential. However, despite the use of pneumatic cushions and the like referred to above, the respiratory masks and the like of the prior art fail to provide an effective seal against the facial contours of a patient or subject. In addition, the use of cords, straps and hoods do not comfortably and conveniently achieve an adequate seal.

U.S. Patent Specification No. 3,357,426 describes an adherent face mask in which a coupling is employed in an attempt to enhance sealing between the face mask and a patient. The coupling is held in place on the face by a sealing flap provided with an adhesive for adhering to a wearer's face. However, the sealing flap is a laterally and inferiorly extending cowl-type mask which adheres to a large surface area of a patient and is cumbersome in use specially in emergencies. The adhesion over a large area particularly on the neck and laterally limits movement, in particular full neck extension and jaw thrust may be limited. Full neck extension is necessary for adequate mask ventilation in the unconscious. In addition, due to the size of the mask, it is cumbersome to manipulate in emergency situations. Rapid removal and reapplication of a respiratory mask is often necessary during an emergency. The coupling employed in the mask is solid. Accordingly, the mask is not practical for patients that may need to be intubated. The adhered solid ring prevents manipulation of the mandible and tongue. The application of external force to locate and hold the mask in place does not improve the adhesion of the cowl-type mask.

In an attempt to overcome the disadvantages of the respiratory masks of the prior art, the pneumatic cushion referred to above, has also been replaced by a non-adhesive dough-like material and

other non-adhesive materials in order to attempt to follow the facial contours of an individual. However, despite the use of the non-adhesive dough material, effective and continuous sealing between a respiratory mask and a subject remains elusive.

- 5 An object of the invention is to overcome the problems of the prior art.

A further object of the invention is to provide a respiratory seal which overcomes the problems of the prior art.

- 10 A still further object of the invention is to provide a ventilation mask and a seal for a ventilation mask which overcomes the problems of the prior art.

A still further object of the invention is to provide a method for sealing a respiratory mask to the face of a subject.

- 15 According to the invention there is provided a seal for sealing a respiratory mask to the face of a subject, the seal comprising a peripheral sealing means for extending around a face engaging periphery of the mask, and an adhesive means for sealably adhering the peripheral sealing means to the face of the subject for  
20 minimising leakage from the respiratory mask between the face engaging periphery of the mask and the face of the subject.

Preferably, the sealing means is formed from the adhesive means.

Advantageously, the seal further comprises a securing means for securing the seal to the face engaging periphery of the mask.

- 25 Preferably, the securing means comprises an adhesive layer on the peripheral sealing means.

Advantageously, the seal is formed with the mask. Suitably, the sealing means comprises a double sided adhesive material.

Advantageously, the double sided adhesive material is of annular shape such that one side of the double sided material forms the adhesive means and the other side of the double sided material forms the securing means. Preferably, the sealing means is  
5 resiliently deformable to accommodate the contours of the face.

Suitably, the periphery sealing means comprises a deformable annular member.

Preferably, the deformable annular member comprises a resilient material. Suitably, the resilient material comprises a plastics  
10 material.

Preferably, a release sheet is provided for protecting the adhesive means. Suitably, a release sheet is provided for protecting the securing means.

Preferably, the seal comprises a plurality of peripheral sealing means. More preferably, the plurality of peripheral sealing means  
15 are laminated together to form a laminate.

Preferably, the innermost sealing means of the laminate comprises the securing means and each of the sealing means comprises an adhesive means. Suitably, the sealing means in the laminate are  
20 sequentially separable.

Advantageously, the adhesive means comprises an adhesive material embedded into or formed into the seal. Preferably, the adhesive means comprises a heat activatable adhesive means. More  
preferably, the heat activatable adhesive means is activatable  
25 prior to contact of the seal with the subject. Suitably, the heat activatable adhesive means is activatable upon contact with the subject. Alternatively, the adhesive is activatable during manufacture of the seal.

Preferably, the seal further comprises a wetting material to wet

facial hair. More preferably, the wetting material comprises an adhesive.

In an alternative embodiment of the invention, the seal comprises a two part seal, the first part of the seal comprising the first  
5 adhesive means and the second part of the seal comprising the securing means. Suitably, the first part is detachably connected to the second part by quick release means.

Preferably, the quick release means is selected from the group comprising hook and eye means, clip means and magnetic means.  
10 More preferably, the hook and eye means comprises Velcro (Trade Mark).

Suitably, the hook and eye means comprises a sealant to form a leak-proof seal between the hooks and eyes.

Suitably, the sealant comprises a viscous liquid.

15 The invention also extends to a respiratory mask comprising a seal as hereinbefore defined. Preferably, the seal extends around the face engaging periphery of the mask.

Advantageously, the respiratory mask comprises a ventilation mask. Alternatively, the respiratory mask comprises a diving mask.  
20 Alternatively, the respiratory mask comprises a surgical mask. Alternatively, the respiratory mask comprises a dust mask.

The invention also extends to a method for sealing a respiratory mask to the face of a subject comprising bonding a face engaging periphery of the mask to the face of the subject for minimising  
25 leakage from the mask between the face engaging periphery and the face of the subject.

Preferably, the face engaging periphery of the mask is bonded to the face of the subject by an adhesive means.



More preferably, the respiratory mask comprises a ventilation mask.

The invention also provides a quick release mechanism comprising a hook and eye means, the hook means being defined on a first part  
5 of the quick release mechanism and the eye means being defined on a second part of the quick release mechanism, the quick release mechanism further comprising a sealant between the hook and eye means to form a fluid-tight seal between the hook and eye means.

Preferably, the sealant comprises a viscous liquid.

10 More preferably, the hook and eye means comprises Velcro (Trade Mark).

The respiratory seal and respiratory mask in accordance with the present invention ensures a substantially fluid-tight seal between the respiratory mask and the facial contours of a subject.  
15 Accordingly, the respiratory mask and seal in accordance with the invention have application in medical procedures such as ventilation masks for resuscitating a patient or for treating a patient using Continuous Positive Airway Pressure (CPAP) and for other applications such as surgical masks, dust masks, breathing  
20 apparatus for fire fighters and the like. The seal in accordance with the invention may be retro-fitted to existing respiratory masks or incorporated during manufacture into respiratory masks. The seal in accordance with the invention may be used either alone or in combination with seal enhancing fittings on masks e.g.  
25 pneumatic cushions and the like.

The sealing means are provided with the adhesive means. The force applied in positioning and/or holding the mask serves to maximise the adhesive seal, even when the external force is continuously applied, reduced or removed. Ideally, the sealing means are  
30 releasably laminated together so that the sealing means may be sequentially separable one from the other commencing with the

outer sealing means which is not provided with the adhesive means. This facilitates use of the ventilating mask many times, since after each use the sealing means with the adhesive means which was attached to the face of the subject may be peeled off from the other sealing means after use, thereby exposing the next sealing means and its adhesive means for sealably adhering to the face of the subject, or the next subject.

The adhesive seal in accordance with the present invention can be exploited in many forms as an adhesive on its own or in combination with other resilient materials which can help to facilitate the adoption of the shape of the facial contours.

The invention will be more clearly understood from the following description of some embodiments thereof which are given by way of example only with reference to the accompanying drawings, in which:

Fig. 1 is a perspective view of a ventilation mask according to the invention;

Figs. 2a and 2b are respectively perspective views of the mask of Fig. 1 in use and a portion of the mask of Fig. 1;

Fig. 3 is a side elevation of the mask of Fig. 1 in use;

Fig. 4 is a side elevation of the mask of Fig. 1;

Fig. 5 is an underneath plan view of the mask of Fig. 1;

Fig. 6 is an end elevation view of the mask of Fig. 1;

Fig. 7 is a side elevation in transverse cross-section of the mask of Fig. 1;

Fig. 8 is a side elevation of a portion of a ventilation

mask according to a second embodiment of the invention;

Fig. 9 is an end elevation in transverse cross-section of a portion of the mask of Fig. 8;

5 Fig. 10 is an underneath plan view of the mask to which the portion of Fig. 8 is attached;

Fig. 11 is an end elevation view of the mask of Fig. 10;

Fig. 12 is a side elevation of the mask of Fig. 10 with the portion of Fig. 8 assembled thereto;

10 Fig. 13 is an end elevation in partial cross-section of the mask of Fig. 12;

Fig. 14 is a side elevation of a portion of another mask according to a third embodiment of the invention;

Fig. 15 is an end elevation in transverse cross-section of the portion of Fig. 14;

15 Fig. 16 is an underneath plan view of the mask to which the portion of Fig. 14 is to be attached;

Fig. 17 is a side elevation of the mask of Fig. 16 with the portion of Fig. 14 attached thereto;

20 Fig. 18 is an end elevation in partial cross-section of the mask of Fig. 17;

Fig. 19 a side elevation of a portion of a ventilation mask according to a fourth embodiment of the invention;

Fig. 20 is an underneath plan view of the mask to which the portion of Fig. 19 is to be attached, and

Fig. 21 is a side elevation of the mask of Fig. 20 with the portion of Fig. 19 attached thereto.

Referring to the drawings and initially to Figs. 1 to 7 there is illustrated a ventilation mask according to the invention which is indicated generally by the reference numeral 1 for engaging the face 2 of a subject over the mouth 3 and nose 4 for ventilating the subject. The ventilation mask 1 comprises a canopy 6 defining a face engaging periphery 8 which engages and follows the contours of the subject.

10 A seal also according to the invention for sealably securing the mask 1 to the face 2 of the subject comprises a peripheral sealing means which is formed by an adhesive means, namely, an annular layer of adhesive 11 which extends around the face engaging periphery 8 of the canopy 6 for sealably adhering the mask 1 to the face 2 of the subject for minimising leakage from the mask 1 between the face engaging periphery 8 and the face of the subject. The depth of the adhesive layer 11 is exaggerated in the drawings for the purpose of illustration. In this embodiment of the invention the adhesive of the adhesive layer 11 is of the type which does not cause a reaction by the subject, and also, is of sufficient bond strength for retaining the mask 1 to the face of the subject during ventilation, but is of such strength as to permit removal of the mask 1 from the face 2 of the subject with minimum discomfort to the subject. A release sheet 12 of annular shape protects the adhesive layer 11 until the mask is ready for use. An air inlet 13 to the canopy 6 facilitates the introduction of air or oxygen for ventilating the subject. A valve (not shown) which is located in the air inlet 13 facilitates alternate delivery of air or oxygen to the subject, and exhausting of exhaled air from the subject.

A strap (not shown) of elastic material may be anchored to the canopy 6 by anchor members for assisting in securing the mask 1 to the subject. The strap would be adapted to pass behind the head

or around the ears of the subject as is the case in known ventilation masks.

In use, the strap if such is provided is adjusted so that the length of the strap is suitable for retaining the mask 1 to the face 2 of the subject with a reasonable degree of pressure. The release sheet 12 is removed from the adhesive layer 11, and the mask 1 is offered up to the face 2 of the subject and pressed onto the face of the subject so that the adhesive layer 11 bonds the mask 1 to the face 2 across the bridge of the nose 4, to the cheeks on both sides of the nose, around by the side of the mouth and below the mouth as illustrated in Fig. 3. The strap is then passed around the head of the subject.

The mask 1 is thus securely adhered to the face of the subject, and ventilation of the subject can commence through the air inlet 13 in conventional form.

It will be appreciated that other inlets may be provided in the canopy 6 for facilitating alternative forms of ventilation. Such arrangements of air inlets and other inlets will be well known to those skilled in the art.

Referring now to Figs. 8 to 13 there is illustrated a ventilation mask 20 according to a second embodiment of the invention. The ventilation mask 20 is substantially similar to the ventilation mask 1 and similar components are identified by the same reference numerals. In the present embodiment, the canopy 6 is provided with a peripheral pneumatic cushion 7 extending around the canopy 6 which defines the face engaging periphery 8 of the ventilation mask 20. The pneumatic cushion 7 is formed by a tubular member 10 which extends around the canopy 6 and is air filled to the extent that the tubular member 10 is resiliently deformable for accommodating the contours of the face 2 of the subject.

However, in the present embodiment, instead of the seal according

to the invention being provided by an adhesive layer 11, the seal according to the invention is provided by a peripheral sealing means, namely, an annular seal 21 of double sided adhesive material. In Figs. 8 and 9 the annular seal 21 is illustrated, and in Figs. 12 and 13 the annular seal 21 is illustrated in position on the ventilation mask 20. The thickness of the double sided material is also exaggerated. Release sheets 22 are provided on the respective opposite sides of the annular seal 21, so that in use one of the release sheets 22 is initially removed and the annular seal 21 secured to the tubular member 10 so that the ventilation mask 20 is then ready for use. Thereafter, use of the ventilation mask 20 is identical to the ventilation mask 1. The remaining release sheet 22 is removed from the annular seal 21 so that the mask 20 may then be bonded to the face of the subject as already described.

A double sided adhesive material can be formed from a double sided adhesive sheet of the type available under the trade name Sellotape (Trade Mark). The materials of the adhesive sheet should be skin compatible and not elicit an allergic or immune response in the subject.

Referring now to Figs. 14 to 18 there is illustrated a ventilation mask 30 according to a third embodiment of the invention. The mask 30 is substantially similar to the mask 1, and similar components are identified by the same reference numeral. However, in the present embodiment a peripheral pneumatic cushion 7 is also provided on the canopy as described above in relation to Figs. 8 to 13. In this embodiment of the invention the seal according to the invention is provided by an annular seal 31 of resiliently deformable plastics material, typically, an open or closed cell plastics material. The plastics material is adapted to conform to the facial features of a subject i.e. is malleable or mouldable.

A securing means for securing the annular seal 31 to the mask 30 comprises an adhesive layer 32 on one face of the seal 31, and an

adhesive means for bonding the seal 31, and in turn the mask 30 to the face of a subject comprises an adhesive layer 33 on the other face of the seal 31. Release sheets 34 are provided for protecting the adhesive layers 32 and 33, and are similar to the  
5 release sheets 22 of the ventilation mask 20. Use of the ventilation mask 30 is identical to the use of the ventilation mask 20, the annular seal 31 being used in similar fashion as the annular seal 21 is used with the ventilation mask 20.

The advantage of the ventilation mask 30 over the ventilation mask  
10 20 is that the annular seal 31 being resilient, further improves sealing between the mask 30 and the face of the subject, since the resilient material of the seal 31 more closely follows the contours of the face of the subject than would the annular seal 21 of the ventilation mask 20. Additionally, the resilient seal 31  
15 may also be used in the absence of the pneumatic cushion.

An example of a suitable seal 31 is a double sided adhesive foam material such as product number 4430 of the 3M (Trade Mark) Corporation.

Referring now to Figs. 19 to 21 there is illustrated a ventilation  
20 mask 40 according to a fourth embodiment of the invention. The ventilation mask 40 is substantially similar to the ventilation mask 1 and similar components are identified by the same reference numerals. The main difference between the ventilation mask 40 and the ventilation mask 1 is that instead of the seal according to  
25 the invention being formed by an adhesive layer, the seal is formed by a plurality of seals 41 which are laminated together. The seals 41 are identical to the resilient seal 31, with the exception that the annular seal 41a which is secured directly to the tubular member 10 is the only one of the seals which is  
30 provided with two adhesive layers 32 and 33. The annular seals 41b are each provided with one adhesive layer, namely, the adhesive layer 33 for securing the respective seals 41 to the subject. The adhesive layer 32 on the seal 41a acts as a securing

means for securing the laminated seals 41 to the tubular member 10, while the adhesive layers 33 on the seals 41b and on the seals 41a act to bond the mask 40 to the face of the subject. The adhesive layers 33 on the seals 41a and each of the seals 41b as  
5 already discussed are similar to the adhesive layer 33 on the seal 31, and of sufficient strength for securing the mask 40 to the face of the subject, but are of strength which permits release of the adhesive layer 33 from the face of the subject without undue discomfort of the subject. Surfaces 45 of the seals 41b are such  
10 as to act as release surfaces for facilitating relatively easy release of a used adhesive seal 41b from the remaining seals 41a and 41b.

In use, the release sheet 34 is removed from the adhesive layer 32 on the seal 41a, and the laminated seals 41 are secured to the  
15 tubular member 10. The remaining release sheet 34 is then removed from the outermost seal 41b for facilitating adhesion of the mask 40 to the face of the subject. After the mask 40 has been removed from the subject, the used seal 41b is peeled off from the remaining seals 41a and 41b so that the mask 40 is then ready for  
20 subsequent use.

An advantage of the mask 40 according to the invention is that it permits the mask to be removed during resuscitation of a subject, should this be necessary due to, for example, vomiting of the subject, and subsequently reapplied.

25 In an alternative embodiment of the invention the seal may be provided by an adhesive gel-like material. For example the seal could be formed from a hydrocolloid gel such as the hydrocolloid dressing material Convatec Granuflex (Trade Mark) material bonded to the pneumatic cushion 7. Alternatively, the gel-like material  
30 could be formed from a silicone gel such as Axelgaard (Trade Mark) EMS electrode gel bonded to the pneumatic cushion 7. The gel-like material could be applied as a bead, strip or rod in the mask assembly process.



While the seals according to the invention for adhering the masks 20, 30 and 40 to the face of the subject have been described as being provided separately, it will be readily apparent to those skilled in the art that the masks 20, 30 and 40 could have been  
5 provided with the annular seals already in place and permanently secured to the mask. Moreover, it will be appreciated by those skilled in the art that the depth of the seals employed will be determined by the presence or absence of other seal-enhancing features such as the pneumatic cushion 7. However, in general the  
10 seals will have a depth of up to about 3cm. The depth or thickness of the seal will also be determined by the shape and flexibility of the canopy 6.

It is envisaged that the seal according to the invention may  
15 comprise sealing materials other than seals of inherent resilience in order to effect bonding of the mask to the face of a subject.

The seal according to the invention may also be provided as a two part laminated seal. For example, one part would be provided with the adhesive means for adhering that part of the seal to the face  
20 of the subject and the other part would be provided with the securing means for adhering that part to the ventilation mask. The respective adhesive means and securing means may, for example, be provided by layers of adhesive applied to the respective parts. The two parts typically, would be provided by backing sheets, one  
25 of which part may have hooks, and the other of which part may have eyes, the hooks and eyes on the respective backing sheets would typically be of the type sold under the Trade Mark VELCRO. This would permit one of the parts to be adhered to the face of the subject and the other of the parts to be adhered to the mask while  
30 the two parts would be separable by means of the VELCRO hooks and eyes. In order to achieve an adequate leak proof seal between the hooks and eyes, it is envisaged that a sealant such as a relatively viscous liquid would be located between the hooks and eyes for forming the leak proof seal. Needless to say, the two  
35 parts may be secured together by means other than VELCRO, for

example, by clips, or other quick release mechanisms or indeed, by magnetic strips or the like.

In one embodiment of the invention the adhesive means may be provided by an adhesive material which may be embedded into or  
5 formed into the seal during preparation and/or construction of the seal to form a tackified material, in which case, the adhesive means may be an adhesive material which when the seal is subjected to heat, the adhesive material comes to the surface of the seal for bonding the seal to the face of the subject. The adhesive  
10 material may be brought to the surface as a result of contact with heat just prior to the seal being brought into contact with the subject, or indeed, during contact with the subject. An example of such a tackified material is polyethylene impregnated with polyisobutylene. Alternatively, the adhesive material may be  
15 brought to the surface of the seal during manufacture of the seal, and a release sheet may be laminated to the surface during or after the adhesive material has been brought to the surface.

In a further embodiment of the invention, the seal is provided with a wetting type material to effect wetting of facial hair to  
20 improve seal formation. Alternatively or in addition a gel-like material may be employed to remove air-pockets and the like in beards and moustaches to enhance sealing. The wetting type material can have an adhesive incorporated therein.

While the face engaging periphery of the mask has been described  
25 in all cases as engaging just beneath the mouth of the subject, it will be appreciated that the face engaging periphery may engage beneath the chin of the subject.

It will also be appreciated that the mask and the seal may be of materials other than plastics material.

30 It will also be appreciated that in the mask, described with reference to Figs. 19 to 21, only one of the annular seals 41 need

be resilient, in other words, only the annular seal 41a need be resilient, the remaining seals 41b may be of any other suitable non-resilient material.

CLAIMS

1. A seal for sealing a respiratory mask (1,20,30,40) to the face (2) of a subject, the seal comprising a peripheral sealing means (11,21,31,41) for extending around a face engaging periphery (8) of the mask (1), and an adhesive means (11,21,31,41) for sealably adhering the peripheral sealing means (11,21,31,41) to the face of the subject for minimising leakage from the respiratory mask (1,20,30,40) between the face engaging periphery (8) of the mask (1,20,30,40) and the face of the subject.
2. A seal as claimed in Claim 1 characterised in that the sealing means (11,21,31,41) is formed from the adhesive means (11,21,33).
3. A seal as claimed in Claim 1 or Claim 2 characterised in that the seal further comprises a securing means (32) for securing the seal to the face engaging periphery (8) of the mask.
4. A seal as claimed in Claim 3 characterised in that the securing means (32) comprises an adhesive layer on the peripheral sealing means (11,21,31,41).
5. A seal as claimed in any of Claims 1 to 4 characterised in that the seal is formed with the mask (1,20,30,40).
6. A seal as claimed in any of Claims 1 to 5 characterised in that the sealing means (11,21,31,41) comprises a double sided adhesive material (21).
7. A seal as claimed in Claim 6 characterised in that the double sided adhesive material (21) is of annular shape such that one side of the double sided material forms the adhesive means and the other side of the double sided material forms the securing means.
8. A seal as claimed in any of Claims 1 to 7 characterised in

that the sealing means (11,21,31,41) is resiliently deformable to accommodate the contours of the face.

9. A seal as claimed in Claim 8 characterised in that the peripheral sealing means (11,21,31,41) comprises a deformable annular member.
10. A seal as claimed in Claim 9 characterised in that the deformable annular member comprises a resilient material.
11. A seal as claimed in Claim 9 characterised in that the resilient material comprises a plastics material.
12. A seal as claimed in any of Claims 1 to 11 characterised in that a release sheet (22,34) is provided for protecting the adhesive means (11,21,31,41).
13. A seal as claimed in any of Claims 3 to 12 characterised in that a release sheet (22,34) is provided for protecting the securing means.
14. A seal as claimed in any of Claims 3 to 13 characterised in that the seal comprises a plurality of peripheral sealing means (11,21,31,41).
15. A seal as claimed in Claim 14 characterised in that the plurality of peripheral sealing means (11,21,31,41) are laminated together to form a laminate.
16. A seal as claimed in Claim 14 characterised in that the innermost sealing means (41a) of the laminate comprises the securing means (32) and each of the sealing means (41b) comprises an adhesive means (11,21,33).
17. A seal as claimed in Claim 16 characterised in that the sealing means (41b) in the laminate are sequentially separable.

18. A seal as claimed Claim 1 or Claim 2 characterised in that the adhesive means (11,21,33) comprises an adhesive material embedded into or formed into the seal.
19. A seal as claimed in Claim 18 characterised in that the  
5 adhesive means (11,21,33) comprises a heat activatable adhesive means.
20. A seal as claimed in Claim 19 characterised in that the heat activatable adhesive means (11,21,33) is activatable prior to contact of the seal with the subject.
- 10 21. A seal as claimed in Claim 20 characterised in that the heat activatable adhesive means (11,21,33) is activatable upon contact with the subject.
22. A seal as claimed in Claim 19 or Claim 20 characterised in that the adhesive is activatable during manufacture of the seal.
- 15 23. A seal as claimed in any of Claims 1 to 22 characterised in that the seal further comprises a wetting material to wet facial air.
24. A seal as claimed in Claim 23 characterised in that the wetting material comprises an adhesive.
- 20 25. A seal as claimed in any of Claims 3 to 11 characterised in that the seal comprises a two-part seal, the first part of the seal comprising the adhesive means and the second part of the seal comprising the securing means.
26. A seal as claimed in Claim 25 characterised in that the  
25 first part is detachably connected to the second part by quick release means.
27. A seal as claimed in Claim 26 characterised in that the

quick-release means is selected from the group comprising hook and eye means, clip means and magnetic means.

28. A seal as claimed in Claim 27 characterised in that the hook and eye means comprises Velcro (Trade Mark).

5 29. A seal as claimed in Claim 27 or Claim 28 characterised in that the hook and eye means comprises a sealant to form a leak-proof seal between the hooks and eyes.

30. A seal as claimed in Claim 29 characterised in that the sealant comprises a viscous liquid.

10 31. A respiratory mask (1,20,30,40) comprising a seal as claimed in any of Claims 1 to 30.

32. A respiratory mask (1,20,30,40) as claimed in Claim 31 characterised in that the seal extends around the face engaging periphery (8) of the mask (1,20,30,40).

15 33. A respiratory mask as claimed in Claim 31 or Claim 32 characterised in that the respiratory mask (1,20,30,40) comprises a ventilation mask (1,20,30,40).

20 34. A respiratory mask (1,20,30,40) as claimed in Claim 31 or Claim 32 characterised in that the respiratory mask (1,20,30,40) comprises a diving mask.

35. A respiratory mask (1,20,30,40) as claimed in Claim 31 or Claim 32 characterised in that the respiratory mask (1,20,30,40) comprises a surgical mask.

25 36. A respiratory mask (1,20,30,40) as claimed in Claim 31 or Claim 32 characterised in that the respiratory mask (1,20,30,40) comprises a dust mask.

37. A method for sealing a respiratory mask (1,20,30,40) to the face of a subject comprising bonding a face engaging periphery (8) of the mask (1,20,30,40) to the face of the subject for minimising leakage from the mask (1,20,30,40) between the face engaging  
5 periphery (8) and the face of the subject.

38. A method as claimed in Claim 37 characterised in that the face engaging periphery (8) of the mask (1,20,30,40) is bonded to the face of the subject by an adhesive means (11,21,33).

39. A method as claimed in Claim 37 or Claim 38 characterised in  
10 that the respiratory mask (1,20,30,40) comprises a ventilation mask (1,20,30,40).

40. A quick release mechanism comprising a hook and eye means, the hook means being defined on a first part of the quick release mechanism and the eye means being defined on a second part of the  
15 quick release mechanism, the quick release mechanism further comprises a sealant between the hook and eye means to form a fluid-tight seal between the hook and eye means.

41. A quick release mechanism as claimed in Claim 40 characterised in that the sealant comprises a viscous liquid.

20 42. A quick release mechanism as claimed in Claim 40 or Claim 41 characterised in that the hook and eye means comprises Velcro (Trade Mark).



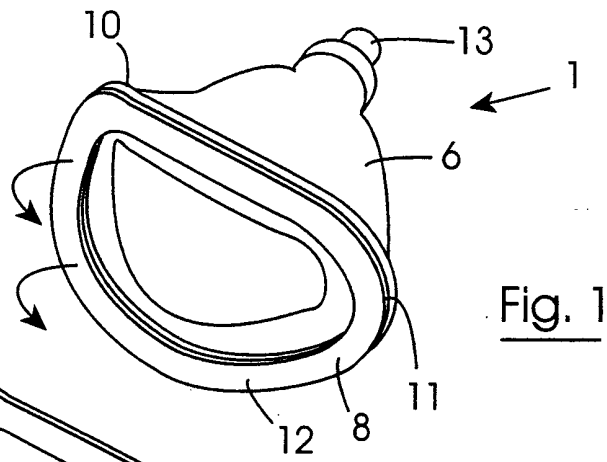

Fig. 1

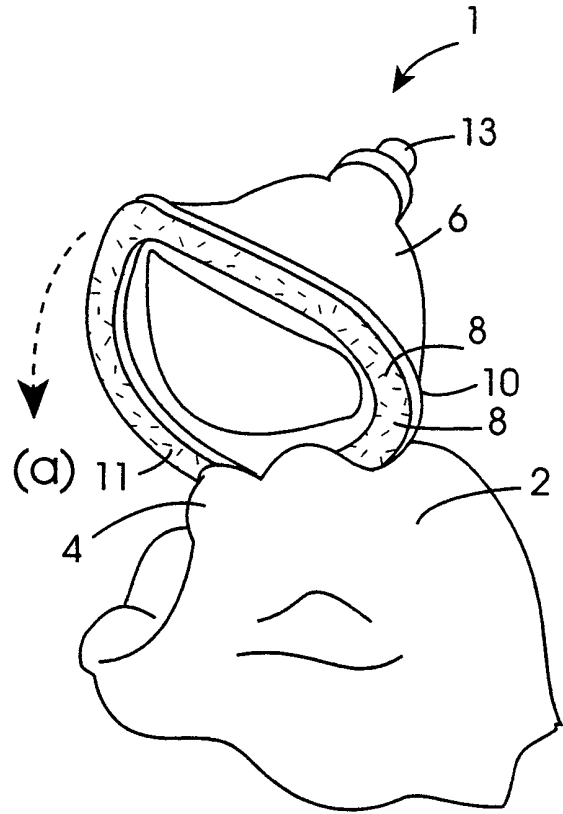
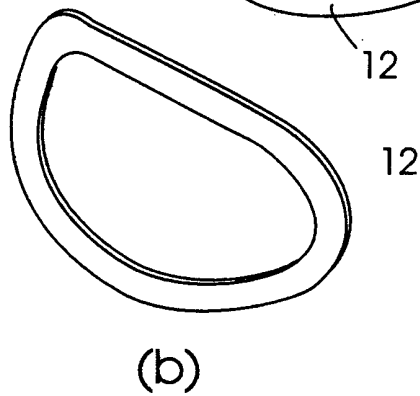

Fig. 2

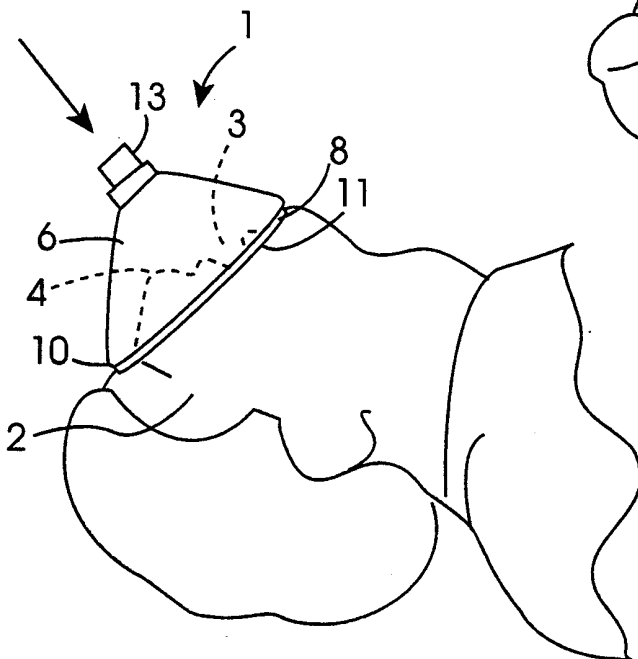

Fig. 3

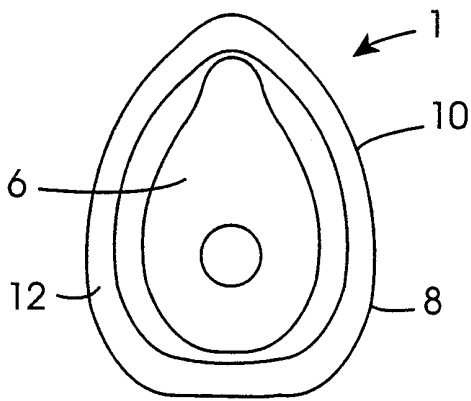

Fig. 5

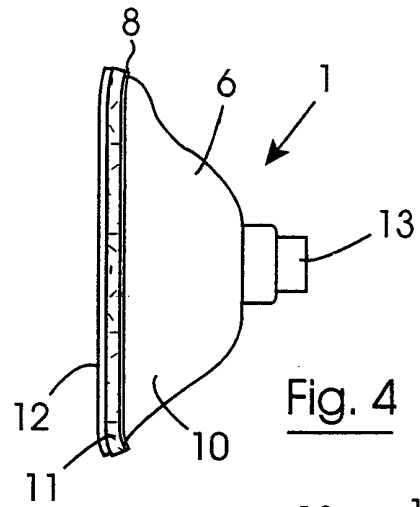

Fig. 4

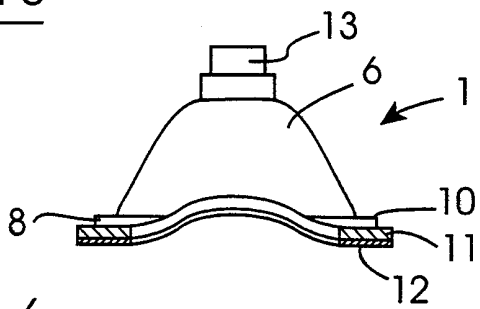

Fig. 6

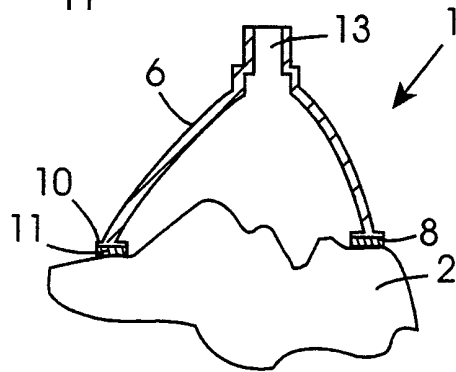

Fig. 7

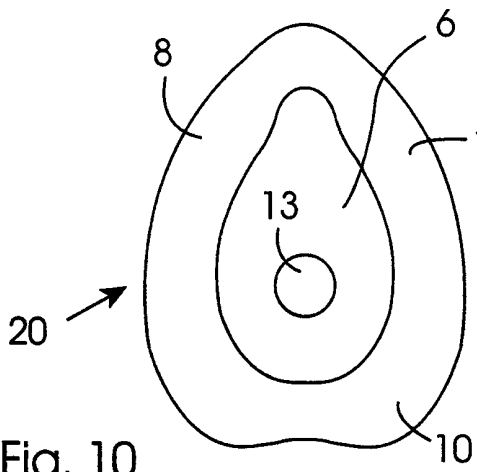

Fig. 10

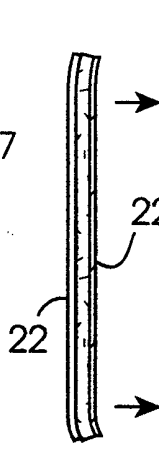

Fig. 8

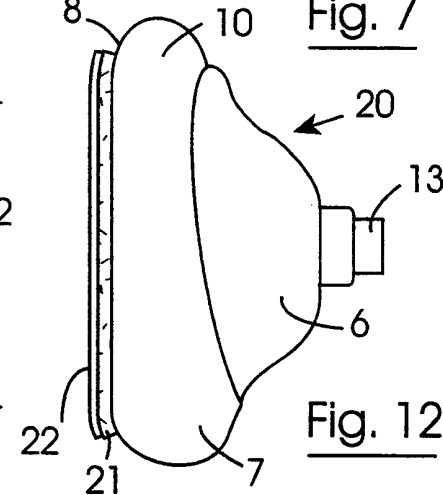

Fig. 12

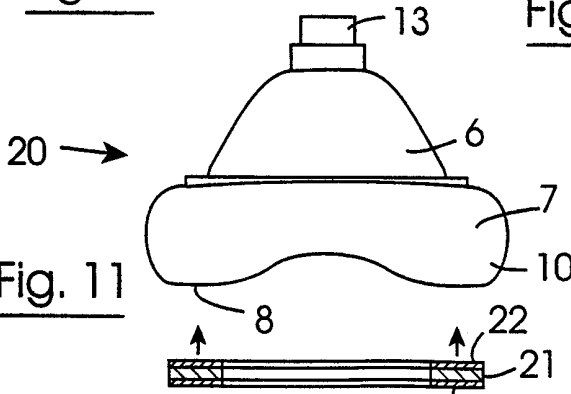

Fig. 11



Fig. 9

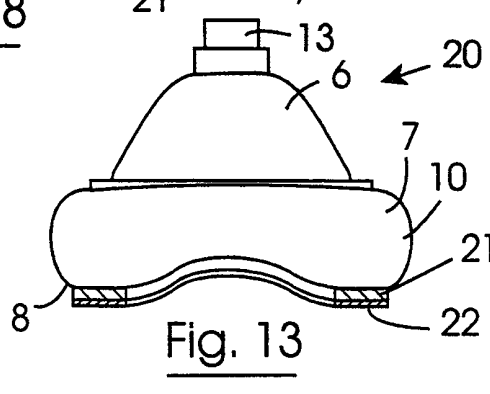
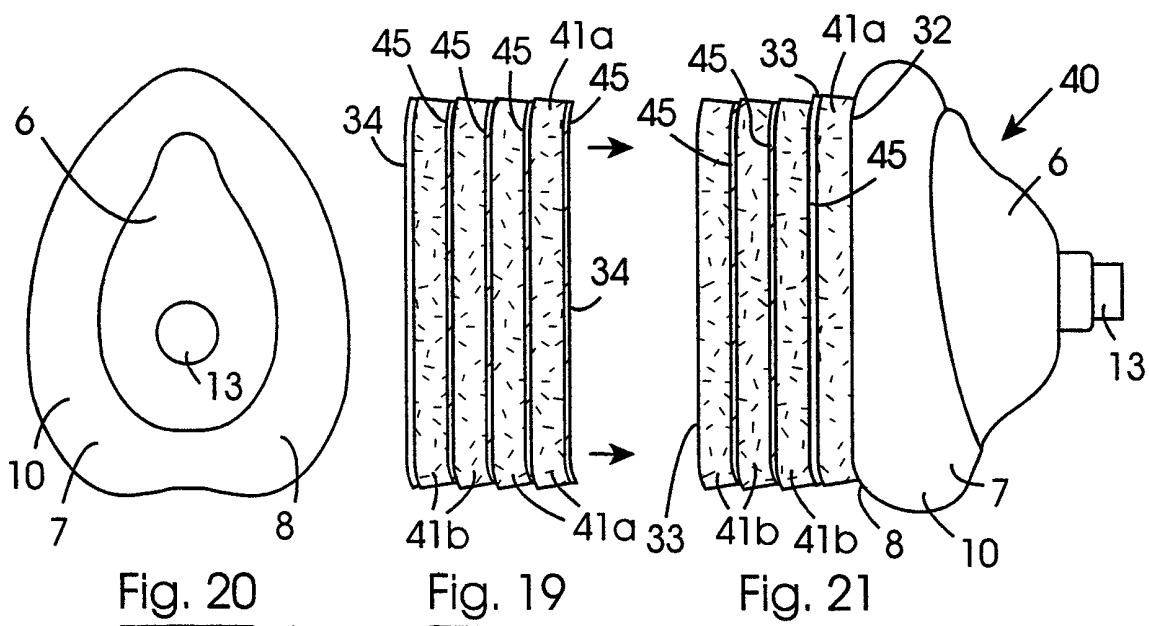
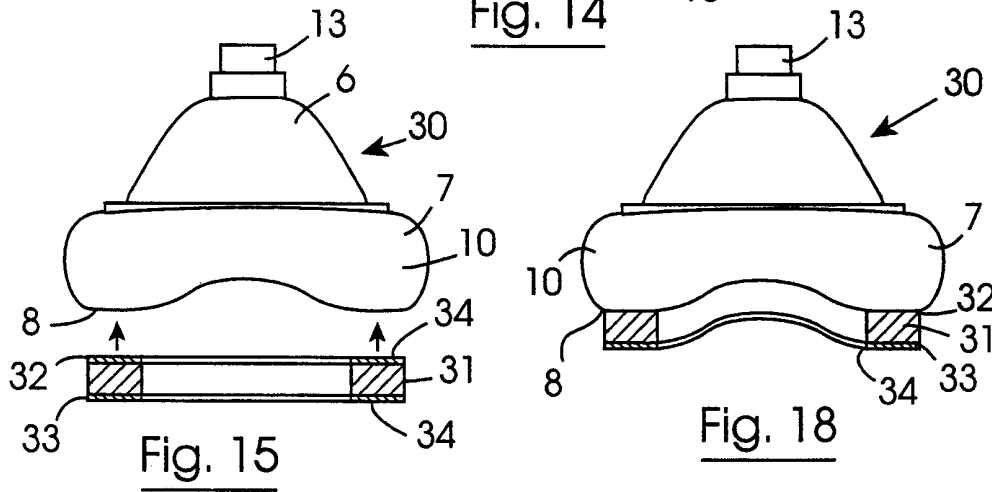
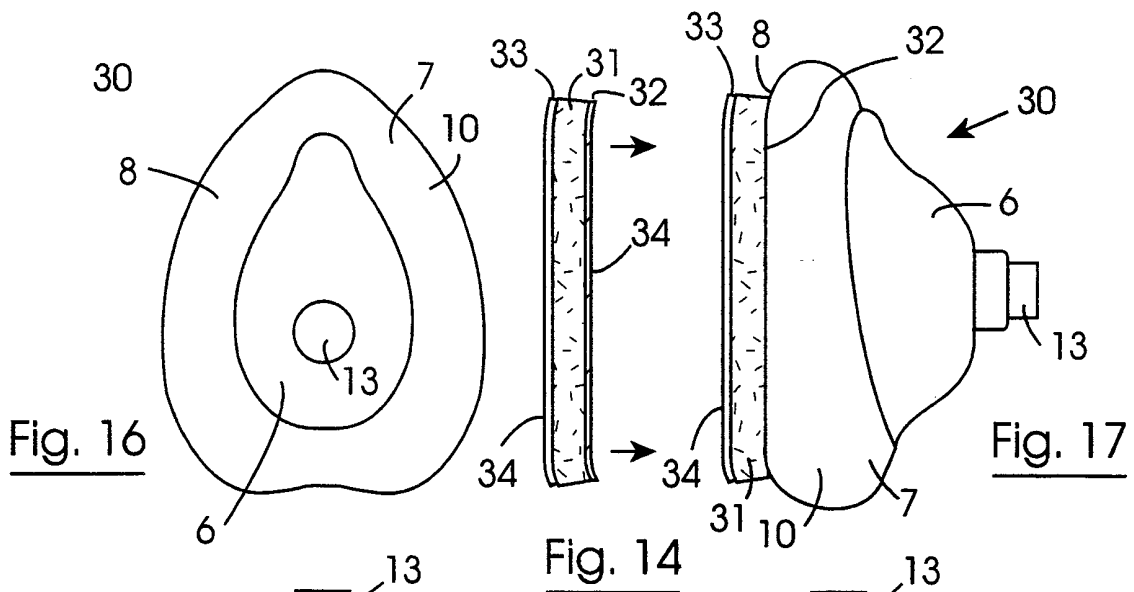

Fig. 13



# INTERNATIONAL SEARCH REPORT

International Application No  
PCT/IE 98/00094

**A. CLASSIFICATION OF SUBJECT MATTER**  
IPC 6 A61M16/06 A62B18/08 A41D13/00

According to International Patent Classification (IPC) or to both national classification and IPC

**B. FIELDS SEARCHED**  
Minimum documentation searched (classification system followed by classification symbols)  
IPC 6 A61M A41D A62B B63C

Documentation searched other than minimum documentation to the extent that such documents are included in the fields searched

Electronic data base consulted during the international search (name of data base and, where practical, search terms used)

**C. DOCUMENTS CONSIDERED TO BE RELEVANT**

Category *	Citation of document, with indication, where appropriate, of the relevant passages	Relevant to claim No.
X	WO 97 00092 A (APOTHEUS LABORATORIES, LTD.) 3 January 1997  see page 16, line 10 - page 17, line 31 see page 18, line 18 - page 19, line 16 see page 26, line 9 - line 32 see page 29, line 29 - page 32, line 5 see figures 2,3,10,12,12A	1-13, 18, 19,25, 31-33, 37-39
A	---	26-29
X	US 4 643 182 A (KLEIN) 17 February 1987  see column 1, line 5 - line 17 see column 8, line 14 - line 29 see column 12, line 27 - line 36  --- -/--	1,31,32, 36

Further documents are listed in the continuation of box C.

Patent family members are listed in annex.

- \* Special categories of cited documents :
- \*A\* document defining the general state of the art which is not considered to be of particular relevance
  - \*E\* earlier document but published on or after the international filing date
  - \*L\* document which may throw doubts on priority claim(s) or which is cited to establish the publication date of another citation or other special reason (as specified)
  - \*O\* document referring to an oral disclosure, use, exhibition or other means
  - \*P\* document published prior to the international filing date but later than the priority date claimed
  - \*T\* later document published after the international filing date or priority date and not in conflict with the application but cited to understand the principle or theory underlying the invention
  - \*X\* document of particular relevance; the claimed invention cannot be considered novel or cannot be considered to involve an inventive step when the document is taken alone
  - \*Y\* document of particular relevance; the claimed invention cannot be considered to involve an inventive step when the document is combined with one or more other such documents, such combination being obvious to a person skilled in the art.
  - \*&\* document member of the same patent family

Date of the actual completion of the international search  <p style="text-align: center;">10 February 1999</p>	Date of mailing of the international search report  <p style="text-align: center;">24. 03 1999</p>
--	--

Name and mailing address of the ISA European Patent Office, P.B. 5818 Patentlaan 2 NL - 2280 HV Rijswijk Tel. (+31-70) 340-2040, Tx. 31 651 epo nl, Fax: (+31-70) 340-3016	Authorized officer  <p style="text-align: center;">SCHOENLEBEN J.</p>
--	---

# INTERNATIONAL SEARCH REPORT

International Application No  
PCT/IE 98/00094

**C.(Continuation) DOCUMENTS CONSIDERED TO BE RELEVANT**

Category °	Citation of document, with indication, where appropriate, of the relevant passages	Relevant to claim No.
X	EP 0 752 214 A (TECNOL MEDICAL PRODUCTS, INC.) 8 January 1997 see column 1, line 3 - line 26 see column 3, line 21 - line 31 see column 3, line 55 - column 4, line 6 see column 5, line 21 - line 34 see column 12, line 43 - line 50 see figure 3	1,18,31, 35
A	-----	23,24

# INTERNATIONAL SEARCH REPORT

International application No.  
PCT/IE 98/00094

## Box I Observations where certain claims were found unsearchable (Continuation of item 1 of first sheet)

This International Search Report has not been established in respect of certain claims under Article 17(2)(a) for the following reasons:

1.  Claims Nos.:  
because they relate to subject matter not required to be searched by this Authority, namely:
  
2.  Claims Nos.:  
because they relate to parts of the International Application that do not comply with the prescribed requirements to such an extent that no meaningful International Search can be carried out, specifically:
  
3.  Claims Nos.:  
because they are dependent claims and are not drafted in accordance with the second and third sentences of Rule 6.4(a).

## Box II Observations where unity of invention is lacking (Continuation of item 2 of first sheet)

This International Searching Authority found multiple inventions in this international application, as follows:

see additional sheet

1.  As all required additional search fees were timely paid by the applicant, this International Search Report covers all searchable claims.
  
2.  As all searchable claims could be searched without effort justifying an additional fee, this Authority did not invite payment of any additional fee.
  
3.  As only some of the required additional search fees were timely paid by the applicant, this International Search Report covers only those claims for which fees were paid, specifically claims Nos.:
  
4.  No required additional search fees were timely paid by the applicant. Consequently, this International Search Report is restricted to the invention first mentioned in the claims; it is covered by claims Nos.:

1-30,31-36, 37-39

Remark on Protest

- The additional search fees were accompanied by the applicant's protest.
- No protest accompanied the payment of additional search fees.

**FURTHER INFORMATION CONTINUED FROM PCT/ISA/ 210**

1. Claims: 1-30,31-36,37-39

A Seal comprising peripheral sealing means and adhesive means, a respiratory mask comprising such a seal and a method for sealing a respiratory mask to the face of a subject.

2. Claims: 40-42

A quick release mechanism comprising hook and eye means

# INTERNATIONAL SEARCH REPORT

Information on patent family members

Inter. Patent Application No

PCT/IE 98/00094

Patent document cited in search report	Publication date	Patent family member(s)	Publication date
WO 9700092    A	03-01-1997	AU    6281396 A CA    2224576 A	15-01-1997 03-01-1997
-----			
US 4643182    A	17-02-1987	NONE	
-----			
EP 752214    A	08-01-1997	US    5724964 A AU    5839796 A CA    2180391 A JP    9103510 A	10-03-1998 16-01-1997 07-01-1997 22-04-1997
-----			