

(12) STANDARD PATENT
(19) AUSTRALIAN PATENT OFFICE

(11) Application No. **AU 2012203494 B2**

- (54) Title
Feedback signaling error detection and checking in MIMO wireless communication systems
- (51) International Patent Classification(s)
H04L 1/00 (2006.01)
- (21) Application No: **2012203494** (22) Date of Filing: **2012.06.15**
- (43) Publication Date: **2012.07.05**
(43) Publication Journal Date: **2012.07.05**
(44) Accepted Journal Date: **2015.03.19**
- (62) Divisional of:
2008247866
- (71) Applicant(s)
InterDigital Technology Corporation
- (72) Inventor(s)
Pan, Kyle Jung-Lin
- (74) Agent / Attorney
Watermark Patent and Trade Marks Attorneys, Level 2 302 Burwood Road, HAWTHORN, VIC, 3122
- (56) Related Art
EP 1628415
US 2006/0209980

2012203494 15 Jun 2012

ABSTRACT

A method of feedback in a wireless transmit receive unit includes providing a precoding matrix (PMI), error checking the (PMI) to produce an error check (EC) bit, coding the PMI and the EC bit and transmitting the coded PMI and EC bit.

2012203494 15 Jun 2012

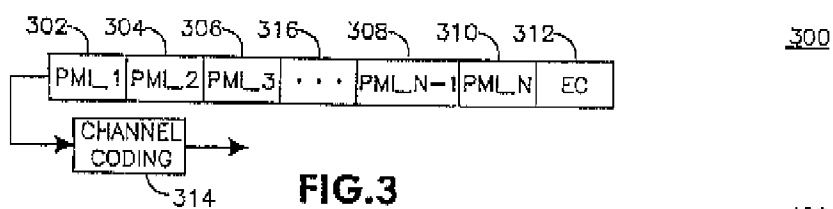

FIG.3

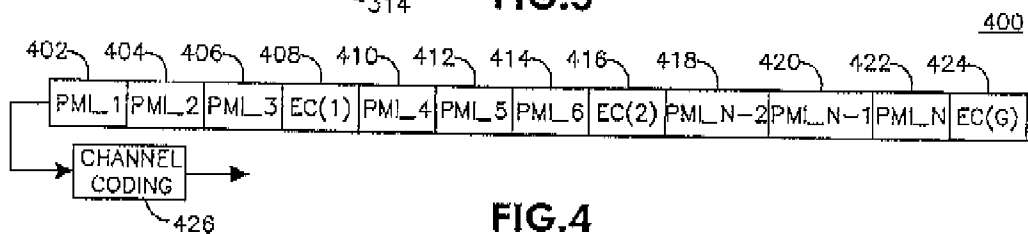

FIG.4

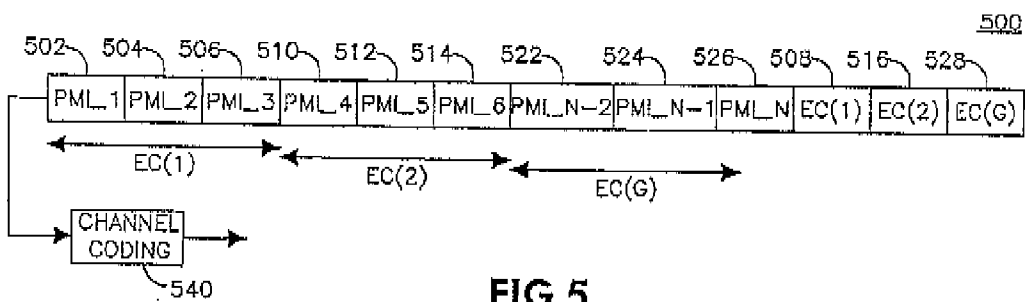

FIG.5

2012203494 15 Jun 2012

F001
Section 29
Regulation 2.9(2)

AUSTRALIA
Patents Act 1990

**ORIGINAL
COMPLETE SPECIFICATION
STANDARD PATENT**

Application
Number:
Lodged:

Invention Title: Feedback signaling error detection and checking in MIMO wireless communication systems

The following statement is a full description of this invention, including the best method of performing it known to us:

P111AHAU/0710

2012203494 15 Jun 2012

[0001] FEEDBACK SIGNALING ERROR DETECTION AND CHECKING
IN MIMO WIRELESS COMMUNICATION SYSTEMS

[0002] FIELD OF INVENTION

[0003] This application is related to wireless communications.

[0004] BACKGROUND

[0005] A goal of the Third Generation Partnership Project (3GPP) Long Term Evolution (LTE) program is to develop new technology, new architecture and new methods for settings and configurations in wireless communication systems in order to improve spectral efficiency, reduce latency and better utilize the radio resource to bring faster user experiences and richer applications and services to users with lower costs.

[0006] Wireless communication systems usually require feedback signaling to enable uplink and downlink communications. For example, hybrid automatic retransmission request (HARQ) enablement requires acknowledge/non-acknowledge (ACK/NACK) feedback. Adaptive modulation and coding (AMC) requires channel quality index (CQI) feedback from a receiver. Multiple Input/Multiple Output (MIMO) systems or precoding requires rank and/or precoding matrix Index (PMI) feedback from a receiver. Typically, this type of feedback signaling is protected by coding and the signaling does not have error checking or detection capabilities. However, efficient signaling is essential to an evolved universal mobile telephone system (UMTS) terrestrial radio access network (E-UTRAN). Adding error check (EC) and error detection capability to the feedback control signaling makes more advanced applications possible. Error check (EC) and error detection capability can enable advanced signaling schemes, enhanced MIMO link performance, reduced system overhead, and increased system capacity.

[0007] An example of an application that may require error detection and checking capability for feedback control signaling is the precoding information validation. The precoding information validation is used to inform a WTRU about

2012203494 15 Jun 2012

the precoding information that is used at an e Node B so that the effective channel seen by the WTRU that contains precoding effects can be reconstructed by the WTRU. This is required for accurate data detection for MIMO systems using precoding, beamforming or the like.

[0008] A wireless transmit receive unit (WTRU) may feedback a precoding matrix index (PMI) or antenna weight to a base station (BS) or an e Node B (eNB). To inform a WTRU of the precoding matrices used at an eNB, the eNB may send a validation message to the WTRU. Each matrix that the WTRU signals as feedback to the eNB may be denoted by PMI_{j1}, PMI_{j2} ... PMI_{jN}, where N is a integer value equal to the total number of matrices. The eNB may send a validation message containing information about N PMIs denoted by PMI_{k1}, PMI_{k2}... PMI_{kN} to the WTRU.

[0009] Each PMI may be represented by L bits. The value of L depends upon the multiple input/multiple output (MIMO) antenna configuration and codebook sizes.

[0010] Communication resources may be assigned to a WTRU. A resource block (RB) consists of M subcarriers, for example M = 12, where M is a positive integer. A resource block group (RBG) or sub-band may include N_{RB} RBs, where N_{RB} may equal, for example, 2, 4, 5, 6, 10, 25 or larger. A system bandwidth can have one or more RBGs or sub-bands depending on the size of bandwidth and value of N_{RB} per RBG or sub-band.

[0011] A WTRU may feed back one PMI for each RBG or sub-band that is configured to it. The terms RBG and sub-band may be used interchangeably. N RBGs, where $N \leq N_{RBG}$, can be configured to or selected by a WTRU for feedback and reporting purpose. If N RBGs or sub-bands are configured to or selected by a WTRU, then the WTRU feeds back N PMIs to the eNB. The eNB may send the validation message consisting of N PMIs back to the WTRU.

[0012] Let N_{PMI} be a number of bits that represents a PMI. The total number of bits for the WTRU PMI feedback is $N \times N_{PMI}$. The maximum number of bits for WTRU PMI feedback is $N_{RBG} \times N_{PMI}$ bits per feedback instance. When a straightforward precoding validation scheme is used, the

2012203494 15 Jun 2012

maximum number of bits for PMI validation message is $N_RBG \times N_PMI$ bits per validation message.

[0013] Table 1 shows a number of bits for WTRU PMI feedback and signaling with the assumption that $N_PMI = 5$ bits. The numbers are summarized for 5, 10 and 20 MHz bandwidth. The second row, N_RB , is the number of RBs per RBG or sub-band, which is in a range of 2 to 100 for 20MHz. The third row, N_RBG per band, is the number of RBGs or sub-bands per 5, 10 or 20 MHz. The value of N_RBG is in a range from one to fifty. The fourth row is the total number of bits used for WTRU PMI feedback signaling per feedback instance. This is for frequency selective precoding feedback or multiple PMI feedback

[0014]

	5 MHz (300 subcarriers)				10 MHz (600 subcarriers)					20MHz (1200 subcarriers)					
	2	5	10	25	2	5	10	25	50	2	5	10	25	50	100
N_RB per RBG	2	5	10	25	2	5	10	25	50	2	5	10	25	50	100
N_RBG per band	18	5	3	1	25	10	5	2	1	50	20	10	4	2	1
Max # of bits for PMI feedback per feedback	65	25	15	5	125	50	25	10	5	250	100	50	20	10	5
Max # of bits for PMI signaling per message	65	25	15	5	125	50	25	10	5	250	100	50	20	10	5
	Assume 12 subcarriers per RB. N_RB : Number of resource blocks. N_RBG : Number of frequency RB groups. N_PMI : Number of bits to represent a PMI. $Max\ number\ of\ bits\ for\ WTRU\ PMI\ feedback = N_RBG \times N_PMI\ bits.$ $Max\ number\ of\ bits\ for\ eNB\ validation\ message = N_RBG \times N_PMI\ bits.$														

Table 1. Maximum number of bits for PMI feedback and PMI validation

[0015] PMI feedback and PMI validation may require over 250 bits per feedback instance and per validation message as shown in the above table. [0016] Feedback error significantly degrades the link and system performance. It would be desirable for feedback bits to be protected with error checking (e.g., channel coding). Furthermore, knowing whether there is an error in a feedback signal improves system performance such as link performance, because the erroneous feedback information can be avoided. Furthermore, knowing whether there is error in the feedback signaling enables the use of advanced signaling schemes or applications such as the precoding confirmation and indication schemes. Precoding confirmation can be sent to confirm the correctness of feedback signaling if there is no error in the feedback signaling. [0017] A single bit or bit sequence may be used for precoding confirmation and may be sufficient for some applications. The use of advanced signaling such as precoding validation using confirmation significantly reduces the signaling overhead. Therefore error checking and detection is desirable.

SUMMARY

[0016] Disclosed is a method and apparatus for feedback type signaling error check, detection and protection in a wireless communication system. Feedback type signaling may include channel quality index (CQI), precoding matrix index (PMI), rank and/or acknowledge/non-acknowledge (ACK/NACK). The disclosure includes a wireless transmit receive unit (WTRU) performing a method that includes providing a PMI(s), producing error check (EC) bit(s), coding the PMI(s) and the EC bit(s), and transmitting the coded PMI(s) and EC bit(s). The method may be applied to other feedback information, such as CQI, rank, ACK/NACK and the like.

[0017] In one aspect the present invention provides a method of feedback in a wireless transmit receive unit (WTRU), the method including:

- the WTRU generating a feedback signal, the feedback signal including at least one of a precoding matrix index (PMI) or a channel quality index (CQI);

- the WTRU determining a number of bits of the feedback signal to be encoded;

- the WTRU selecting a type of error detection and correction scheme to apply to the feedback signal based on the number of bits of the feedback signal to

be encoded, wherein selecting the type of error detection and correction scheme includes selecting a number of error check (EC) bits to attach to the feedback signal and selecting a type of channel coding scheme to apply to the feedback signal and the selected number of EC bits;

the WTRU encoding the feedback signal and the selected number of EC bits using the selected type of channel coding scheme; and

the WTRU transmitting the encoded feedback signal.

[0018] In another aspect the present invention provides a wireless transmit receive unit (WTRU) including a processor configured, at least in part, to:

generate a feedback signal, the feedback signal including at least one of a precoding matrix index (PMI) or a channel quality index (CQI);

determine a number of bits of the feedback signal to be encoded;

select a type of error detection and correction scheme to apply to the feedback signal based on the number of bits of the feedback signal to be encoded, wherein the processor is configured to select the type of error detection and correction scheme by selecting a number of error check (EC) bits to attach to the feedback signal and by selecting a type of channel coding scheme to apply to the feedback signal and the selected number of EC bits;

encode the feedback signal and the selected number of EC bits using the selected type of channel coding scheme; and

transmit the encoded feedback signal.

[0019] In a further aspect the present invention provides a method for a wireless transmit receive unit (WTRU), the method including:

the WTRU determining to transmit a first feedback signal in a first transmission time interval (TTI), wherein the first feedback signal includes a first group of precoding matrix indices (PMIs);

the WTRU selecting a first type of error detection and correction scheme to apply to the first feedback signal based on a number of bits of the first feedback signal to be encoded, wherein selecting the first type of error detection and correction scheme to apply to the first feedback signal includes selecting a number of cyclic redundancy check (CRC) bits to attach to the first feedback signal and selecting a type of channel coding scheme to apply to the first feedback signal and the selected number of CRC bits;

the WTRU applying the first type of error detection and correction scheme to the first feedback signal;

the WTRU transmitting the encoded first feedback signal in the first TTI after applying the first type of error detection and correction scheme;

the WTRU determining to transmit a second feedback signal in a second TTI, wherein the second feedback signal includes a second group of precoding matrix indices (PMIs);

the WTRU selecting a second type of error detection and correction scheme to apply to the second feedback signal based on a number of bits of the second feedback signal to be encoded;

the WTRU applying the second type of error detection and correction scheme to the second feedback signal; and

the WTRU transmitting the encoded second feedback signal in the second TTI after applying the second type of error detection and correction scheme.

[0020] In yet another aspect the present provides a wireless transmit receive unit (WTRU) including a processor configured, at least in part, to:

generate a feedback signal, the feedback signal including at least one of a precoding matrix index (PMI) or a channel quality index (CQI);

determine a number of bits of the feedback signal to be encoded;

select a number of error check (EC) bits to attach to the feedback signal based on the number of bits of the feedback signal to be encoded;

selecting a type of channel coding scheme to apply to the feedback signal and the selected number of EC bits based on the number of bits of the feedback signal to be encoded;

encode the feedback signal and the selected number of EC bits using the selected type of channel coding scheme; and

transmit the encoded feedback signal.

BRIEF DESCRIPTION OF THE DRAWINGS

[0021] A more detailed understanding may be had from the following description, given by way of example in conjunction with the accompanying

2012203494 15 Jun 2012

drawings wherein:

- [0022] Figure 1 shows a wireless communication system including a plurality of WTRUs and an eNB;
- [0023] Figure 2 is a functional block diagram of the WTRU and the eNB of the wireless communication system of Figure 1;
- [0024] Figure 3 is a block diagram of PMI feedback with error checking and correction in accordance with one embodiment;
- [0025] Figure 4 is a block diagram of PMI feedback with error checking and correction in accordance with another embodiment;
- [0026] Figure 5 is a block diagram of PMI feedback with error checking and correction in accordance with an alternative embodiment;
- [0027] Figure 6 is a block diagram of PMI feedback with error checking and correction in accordance with another alternative embodiment;
- [0028] Figure 7 is a block diagram of PMI feedback with error checking and correction in accordance with yet another alternative embodiment;
- [0029] Figure 8 is a block diagram of PMI feedback with error checking and correction in accordance with yet another alternative embodiment;
- [0030] Figure 9 is a block diagram of PMI and CQI feedback with error checking and correction in accordance with yet another alternative embodiment;
- [0031] Figure 10 is a block diagram of PMI and CQI feedback with error checking and correction in accordance with yet another alternative embodiment;
- [0032] Figure 11 is a block diagram of PMI, CQI and ACK/NACK feedback with error checking and correction in accordance with yet another embodiment; and
- [0033] Figure 12 is a block diagram of PMI, CQI and ACK/NACK feedback with error checking and correction in accordance with yet another embodiment.

[0034] **DETAILED DESCRIPTION**

[0035] When referred to hereafter, the terminology "wireless transmit/receive unit (WTRU)" includes but is not limited to a user equipment (UE), a mobile station, a fixed or mobile subscriber unit, a pager, a cellular

2012203494 15 Jun 2012

telephone, a personal digital assistant (PDA), a computer, or any other type of user device capable of operating in a wireless environment. When referred to hereafter, the terminology "base station" includes but is not limited to a Node-B, a site controller, an access point (AP), or any other type of interfacing device capable of operating in a wireless environment.

[0036] Figure 1 shows a wireless communication system 100 including a plurality of WTRUs 110 and an eNB 120. As shown in Figure 1, the WTRUs 110 are in communication with the eNB 120. Although three WTRUs 110 and one eNB 120 are shown in Figure 1, it should be noted that any combination of wireless and wired devices may be included in the wireless communication system 100.

[0037] Figure 2 is a functional block diagram 200 of the WTRU 110 and the eNB 120 of the wireless communication system 100 of Figure 1. As shown in Figure 2, the WTRU 110 is in communication with the eNB 120. The WTRU 110 is configured to transmit feedback signals and control signals to the eNB 120. The WTRU is also configured to receive and transmit feedback and control signals from and to the eNB. Both the eNB and the WTRU are configured to process signals that are modulated and coded.

[0038] In addition to the components that may be found in a typical WTRU, the WTRU 110 includes a processor 215, a receiver 216, a transmitter 217, and an antenna 218. The receiver 216 and the transmitter 217 are in communication with the processor 215. The antenna 218 is in communication with both the receiver 216 and the transmitter 217 to facilitate the transmission and reception of wireless data.

[0039] In addition to the components that may be found in a typical eNB, the eNB 120 includes a processor 225, a receiver 226, a transmitter 227, and an antenna 228. The receiver 226 and the transmitter 227 are in communication with the processor 225. The antenna 228 is in communication with both the receiver 226 and the transmitter 227 to facilitate the transmission and reception of wireless data.

2012203494 15 Jun 2012

[0040] A WTRU may transmit a feedback signal (e.g., PMI feedback) to an eNB. Error check (EC) (e.g., Cyclic Redundancy Check (CRC)) bits may be attached to the feedback signal (e.g., PMI feedback). Both the feedback signal (e.g., PMI) and the EC bits may be encoded prior to transmission. The feedback signal may include PMI, CQI, rank, ACK/NACK or other type feedback signal. While this disclosure makes reference to a PMI bit, CQI bit, EC bit and the like, one skilled in the art may recognize that PMI feedback, CQI feedback and error checking and correction may be, and in most cases is multiple bits. Although feedback signals such as PMI or CQI are used as examples other type feedback signals may also be used.

[0041] Different type channels may be used for transmitting and carrying the feedback type signal. For example, both control type channels and data type channels may be used to carry the feedback type signal. An example of a control type channel is the physical uplink control channel (PUCCH). An example of a data type channel is the physical uplink shared channel (PUSCH). However, one skilled in art will recognize that the method and apparatus disclosed herein are independent of channel choice.

[0042] The PMI and EC bits may be coded together, with or without data bits. Both data type channels and control type channels may be used to transmit the feedback signal and EC bits. For example a data type channel (e.g., the physical uplink shared channel (PUSCH)) may be used to transmit PMI and EC bits. A control type channel (e.g., the physical uplink control channel (PUCCH)) may also be used to transmit PMI and EC bits.

[0043] Alternatively, PMI and EC bits may be coded with a first coding scheme and data bits may be coded with a second coding scheme. Each of the coding schemes may be different. For example, convolutional coding or Reed-Muller coding may be used for the feedback type signal and while turbo coding is used for the data type signal. Alternatively, the coding schemes may be the same, but with different parameters and settings to address different error rate requirements for feedback type signal and data type signal. The data type

2012203494 15 Jun 2012

channel (e.g., PUSCH) may be used to transmit PMI and EC bits. The control type channel (e.g., PUCCH) may also be used to transmit PMI and EC bits.

[0044] PMI and EC bits may be separately coded for each group, if grouping is used for feedback type signaling.

[0045] All the PMI and/or EC bits may be fed back or reported at the same time. For example, all the PMI and/or EC bits may be reported in a same transmission time interval (TTI). Alternatively, the feedback type bits and the error checking bits may be reported at a different time. For example, PMI and/or EC bits may be split into groups and reported in different TTIs.

[0046] Error checking and detection methods such as cyclic redundancy check (CRC), for example, may be used. If CRC is used, it may be, for example, 24-bit CRC or 16-bit CRC. The length of the CRC may be varied, and the actual length used may depend on design choices.

[0047] CRC bits may be attached to feedback type signals and transmitted on a data type channel to carry the feedback type signal bits and CRC bits. The feedback type signals may be, for example, PMI, CQI, rank or ACK/NACK. The data type channel may be, for example, a PUSCH. A data type channel has a large capacity and can accommodate a relatively large number of bits. Therefore, the CRC can be, for example, 24-bit CRC, 16-bit CRC or some other length CRC. Long CRC may be used, and is preferable as it provides for better error checking. While this may add additional overhead due to the addition of CRC bits, the PUSCH may have the capacity to handle the larger number of bits. Using a data channel, such as PUSCH, allows for the transmission of feedback signals such as PMI, CQI, rank and ACK/NACK in a single TTI. Therefore, a feedback type signal with a long CRC that provides better error check capability can be implemented.

[0048] Alternatively, CRC bits may be attached to feedback type signals and transmitted on a control type channel. The CRC can be a 24-bit CRC, 16-bit CRC or other length CRC. Typically, control type channels may not have large capacity to carry a large number of bits. In order to transmit CRC bits and the feedback type signals, the transmission may be split and transmitted multiple

2012203494 15 Jun 2012

times. The PMI feedback signal may be split, and transmitted in multiple TTIs. For example, one PMI may be transmitted in each TTI until all the feedback signals are transmitted. CQI or other feedback signals can be handled in a similar way.

[0049] PMI, CQI and/or other feedback type signals can be transmitted separately at different times or in different TTIs. In general, a control type channel (e.g. PUCCH) may not carry large number of bits each time and if there are large number of feedback bits needed to be sent, the feedback bits can be divided or split into groups. Each group may be reported, one at a time. Each feedback instance may contain a single PMI, CQI, other feedback signal, or combination of feedback signals. The CRC can be fed back or transmitted at the same time (in the same TTI) as PMI or CQI. Alternatively, the CRC can be fed back or transmitted separately from PMI or CQI. That is, CRC can be transmitted at different times or in different TTIs from the times or TTIs that the PMI or CQI are transmitted. CRC can also be divided into segments or groups, and each CRC segment may be transmitted or fed back with feedback signal at the same time or in the same TTI. Each CRC segment can also be transmitted at different time or different TTI.

[0050] Use of CRC attached to the feedback signal can apply to a single feedback signal such as one PMI and/or one CQI. Such single feedback scheme may be used when non-frequency selective feedback or wideband feedback (one feedback per entire bandwidth or per entire configured bandwidth) is used.

[0051] Other error check or detection methods such as parity check (including a single-bit parity check) or a block parity check, for example, may also be used. The disclosure herein is not limited to any one particular error checking scheme, as would be recognized by one skilled in the art.

[0052] Coding schemes such as convolutional coding, Reed-Solomon or Reed-Muller coding, for example, may be used. Other coding schemes, for example, turbo coding and low density parity check (LDPC) code, may also be considered. If the feedback is transmitted via a data type channel (e.g., physical uplink shared channel (PUSCH)), convolutional or block coding may be suitable

2012203494 15 Jun 2012

because the data type channel (e.g., PUSCH) allows transmission of a large number of bits. Reed-Muller or Reed-Solomon coding also may be suitable due to a moderate number of bits being coded by these coding schemes. The disclosure herein is not limited to any one particular coding scheme, as would be recognized by one skilled in the art.

[0053] Figure 3 is a block diagram 300 of PMI feedback with error checking and correction in accordance with one embodiment. Multiple PMIs configured as PMI_1 302, PMI_2 304, PMI_3 306 through PMI_N-1 308 and PMI_N 310 are shown in Figure 3. EC bits 312 are attached to the PMI signal 316. The EC bits 312 could be CRC bits of 24 bit length, 20 bit length or 16 bit length. Other lengths of CRC may also be used. PMI bits (302-310) and the EC bits 312 are encoded by a channel coding function 314 prior to transmission. The channel coding can be performed jointly for all PMIs and EC. The jointly encoded PMIs and EC can be transmitted at the same time or in the same TTI. The jointly encoded PMIs and EC can be transmitted at a different time or in different TTIs. Alternatively the channel coding can be performed separately for each PMI and the EC bits or for a group of PMIs and EC. The EC bits can be divided into segments and each EC bit segment can be separately channel encoded and transmitted.

[0054] For example if there are an integer number "N" PMIs, each PMI may be 4 bits and each EC may be 24 bits, using, for example, 24 bit CRC. The total number of bits is $4N+24$ bits. The total number of bits can be jointly encoded using channel coding (e.g., convolutional coding). The encoded bits can be transmitted or fed back at one time in a single TTI. The total number of encoded bits can also be transmitted or fed back at several different time, or different TTIs. For example, the encoded bits may be transmitted an integer number "M" times in M different TTIs. Each TTI may transmit $(4N+24)/M$ original information and CRC bits. The $(4N+24)/M$ original information and CRC bits in each TTI may contain PMI bits and/or CRC bits. If the TTI contains a combination of PMI and CRC bits, then $4N/M$ PMI bits and $24/M$ CRC bits may

2012203494 15 Jun 2012

be included in a single TTI. If $M=N$, 4 PMI bits and a fractional portion of the CRC bits may be transmitted in a single TTI.

[0055] Alternatively, a 24 bit CRC can be divided into 6 segments, each with 4 bits, which is the same number of bits as in a PMI. Each PMI and each CRC segment may be separately or jointly encoded and transmitted in a TTI.

[0056] The EC bits 312 can be a CRC, for example. The channel coding function 314 can be convolution coding, for example. Error checking and detection methods, such as a parity check, can also be used, and other channel coding methods, such as Reed-Muller coding or Reed-Solomon coding, for example, can also be used.

[0057] Each PMI may represent precoding information for a sub-band, an RBG, a group of sub-bands or a wideband. For example, PMI_1 can be a wideband PMI ("average" precoding information for a whole band) and PMI_2 to PMI_N can be sub-band PMIs or averaged PMIs, each corresponding to a precoding information for a sub-band, and RBG, or a group of sub-bands.

[0058] Similarly CQI and other feedback type signals can be added with error check capability by attaching CRC, channel coded and transmitted as described previously.

[0059] PMI feedback signaling may be combined into groups with separate error checking for each group of PMIs. EC bits may be attached to each group of PMIs before channel coding.

[0060] Figure 4 is a block diagram 400 of PMI feedback with error checking and correction in accordance with another embodiment, where PMI_1 402, PMI_2 404 and PMI_3 406 are grouped together and a first error check EC(1) 408 is attached. PMI_4 410, PMI_5 412 and PMI_6 414 are grouped together and are attached with EC(2) 416. PMI_N-2 418, PMI_N-1 420 and PMI_N 422 are grouped together and are attached with EC(G) 424. PMI (402-406, 410-414, 418-422) and EC 408, 416, 424 are coded by channel coding function 426.

[0061] As state above, the EC could be a CRC. An error checking, detection and correction method may be selected based on a total number of bits that are encoded. The EC may use, for example, a short or long CRC, a single parity bit

2012203494 15 Jun 2012

or a block parity check bit. Other error checking, correction and detection methods, such as advanced parity checking, for example, may be used.

[0062] The channel coding function may use, for example, convolutional coding or Reed-Solomon coding. Other channel coding methods, such as block coding, turbo coding or LDPC, for example, may also be used.

[0063] PMIs can be divided into several groups and groups of PMIs can be transmitted in different transmission time intervals (TTI). Groups of PMIs may also be transmitted in a single TTI. Each group may be reported after channel coding. This is referred to as frequency selective feedback and reporting of multiple PMIs. CQI, rank and ACK/NACK signals may also be fed back or reported on a frequency selective basis.

[0064] PMI₁ 402, PMI₂ 404, PMI₃ 406 and EC(1) 408 may be reported in a single TTI, for example TTI(1). PMI₄ 410, PMI₅ 412, PMI₆ 414 and EC(2) 416 may be reported in a second TTI, for example TTI(2). PMI_{N-2} 418, PMI_{N-1} 420, PMI_N 422 and EC(G) 424 may be reported in another TTI, for example TTI(G).

[0065] If the error detection or checking mechanism is disabled or if the error detection or checking capability is removed, there is no EC bit attachment. In that case, PMI group 1 (PMI₁ 402, PMI₂ 404, PMI₃ 406) may be reported in TTI(1), PMI group 2 (PMI₄ 410, PMI₅ 412, PMI₆ 414) may be reported in TTI(2) and PMI group G (PMI_{N-2} 418, PMI_{N-1} 420, PMI_N 422) may be reported in TTI(G). The reporting may occur with or without EC bits.

[0066] Figure 5 is a block diagram of PMI feedback with error check and correction in accordance with an alternative embodiment. The error check bits EC(1) 508 are used for PMI₁ 502, PMI₂ 504 and PMI₃ 506. The error check bits EC(2) 516 are used for PMI₄ 510, PMI₅ 512 and PMI₆ 514 and the error check bits EC(G) 528 are used for PMI_{N-2} 522, PMI_{N-1} 524 and PMI_N 526. The PMI bits and the EC bits are coded by channel coding function 540 prior to transmission.

[0067] In another alternative embodiment, the PMIs may be separated into groups, and each group has an associated error detection and check value. The

2012203494 15 Jun 2012

feedback signaling and error check of each group are coded separately. The coded feedback bits and EC bits can be transmitted in the same TTI or in different TTIs. Each PMI group, with its associated EC, is coded individually.

[0068] Figure 6 is a block diagram 600 of PMI feedback with error check and correction in accordance with the other alternative embodiment. PMIs are divided into G groups for error detection and/or correction. EC(1) 620 is attached to PMI_1 602, PMI_2 604 and PMI_3 606, EC(2) 622 is attached to PMI_4 608, PMI_5 610 and PMI_6 612 and EC(N) 624 is attached to PMI_N-2 614, PMI_N-1 616 and PMI_N 618. PMI_1 602, PMI_2 604 and PMI_3 606 and EC (1) 620 are encoded by a first channel coding function 630. PMI_4 612, PMI_5 614 and PMI_6 616, along with EC(2) 622 are encoded by second channel coding function 640. PMI_N-2 614, PMI_N-1 616 and PMI_N 618, along with EC(G) 824 are encoded by an Gth channel coding function 650. Error checking, correction and detection methods may be chosen based on the number of bits requiring encoding. The EC may use, for example, a CRC that may be, for example, 24 bits, 20 bits or 16 bits. The EC may also use a single parity bit or block parity check bits that have fewer bits than 16 bits. The EC may also use, for example, error checking and detection methods such as advanced parity check.

[0069] The channel coding functions 630, 640, 650 may use, for example, convolutional coding or Reed-Solomon coding. Other appropriate channel coding such as block coding, turbo coding or LDPC may also be used.

[0070] The EC bits can be divided into several groups, each group of EC bits can be fed back or reported at the same time or at different time. For example each group of EC bits can be fed back or reported in the same or different TTIs. Each group is reported after joint or separate channel coding for each group.

[0071] Each PMI group can be reported in a different TTI or together in the same TTI. Each group is reported after separate channel coding of groups. Also, other feedback signaling, such as CQI, rank, and ACK/NACK, for example, may be used.

2012203494 15 Jun 2012

[0072] PMI₁ 602, PMI₂ 604, PMI₃ 606 and EC(1) 620 may be reported in TTI(1). PMI₄, PMI₅, PMI₆ and EC(2) may be reported in TTI(2), and PMI_{N-2}, PMI_{N-1}, PMI_N and EC(G) may be reported in TTI say TTI(G).

[0073] If the error detection or check mechanism is disabled or if error detection or check capability is removed, there may be no EC bits attachment. The PMI groups may then be reported without the EC bits. PMI group 1 (PMI₁ 402, PMI₂ 404, PMI₃ 406) may be reported in a TTI(1), PMI group 2 (PMI₄ 410, PMI₅ 412, PMI₆ 414) may be reported in TTI(2) and PMI group G (PMI_{N-2} 418, PMI_{N-1} 420, PMI_N 422) may be reported in TTI(G). Each reporting group may have separate channel coding.

[0074] When the number of PMI groups is equal to the number of PMIs (G=N), then there is one PMI per each PMI group. Each PMI may be attached with EC (e.g., CRC) bits and encoded separately. Each PMI may be reported at different times. PMI₁ 702, PMI₂ 704 and PMI_N 706 may be reported in different TTIs. For example, PMI₁ 702 may be reported in TTI(1), PMI₂ 704 in TTI(2) and PMI_N 706 in TTI(N). The feedback or reporting may occur via a control type channel (e.g., physical uplink control channel (PUCCH)).

[0075] Alternatively, PMI₁ 704, PMI₂ 70, PMI_N 706 may be reported at the same time. For example PMI₁ 704 to PMI_N 706 may be reported in a single TTI. This may occur via the data type channel (e.g., PUSCH), due the ability of the data type channel (e.g., PUSCH) to handle more bits. Other feedback signals, such as CQI, rank, and ACK/NACK, for example, may be used with or instead of PMI.

[0076] Figure 7 is a block diagram of PMI feedback with error checking and correction in accordance with yet another alternative embodiment. PMIs are divided into G groups for error check and detection, with G=N. PMI₁ 702 is attached with error check bits EC(1) 712, PMI₂ 704 is attached with EC(2) 714 and PMI_N 706 are attached with EC(N) 716. Each PMI/EC pair is encoded by the channel coding function 720. Appropriate error checking, correction and error detection schemes may be used, and may depend on the number of bits required to be encoded. For example, a particular EC may use a CRC, for

2012203494 15 Jun 2012

example, 24-bit CRC, short CRC, a single parity bit or block parity check bits. Channel coding may use Reed Solomon coding, for example. Other appropriate error check and detection such as long CRC or other parity check schemes may be used. Other appropriate channel coding such as block coding, convolutional coding, turbo coding or LDPC may also be use.

[0077] Using frequency selective reporting, PMI₁ 702 may be reported in TTI(1), PMI₂ 704 in TTI(2) and PMI_N 706 in TTI(N). These PMIs may be reported via the control type channel (e.g., PUCCH). Alternatively, PMI₁ to PMI_N can be reported in a single TTI via the data type channel (e.g., PUSCH). Other feedback signaling, such as CQI, rank and ACK/NACK, for example, may be used.

[0078] Figure 8 is a block diagram of PMI feedback with error checking and correction in accordance with yet another alternative embodiment. EC(1) 812 may be used for PMI₁ 802, EC(2) 814 may be used for PMI₂ (804) and EC(N) 816 may be used for PMI_N (806). PMIs and ECs are coded either separately or jointly in the channel coding function 820.

[0079] PMI₁ 802 may be reported in TTI(1), PMI₂ 804 may be reported in TTI(2) and PMI(N) 806 may be reported in TTI(N). PMI₁ 802, PMI₂ 804 and PMI_N 806 can be separately coded and reported in different or the same TTIs. Alternatively PMI₁ 802, PMI₂ 804, and PMI_N 806 can be jointly coded, split, and reported in different TTIs. Furthermore PMI₁ 802, PMI₂ 804 and PMI_N 806 can be jointly coded and reported in the same TTI. Alternatively, PMI₁ 802, PMI₂ 804 and PMI_N 806 can be separately coded with different protection schemes and reported in the same TTI. CQI, rank and ACK/NACK may be used as well.

[0080] Figures 3 to 8 depict error checking, coding and feedback for PMI, and show a single type feedback signal. CQI and other type feedback signals can be substituted for PMI.

[0081] Figures 9 through 12 depict error checking, coding, transmission and feedback for more than one type feedback signal. Figures 9 through 12 are discussed in detail below.

2012203494 15 Jun 2012

[0082] PMI feedback and other type control signaling may be error checked separately with the same or different error checking and then encoded together. For example, a first type feedback signal, which may be a PMI, can be attached with a first EC, which may be a CRC, such as a 24 bit CRC. A second type feedback signal, which may be a CQI, may be attached with the same EC.

[0083] In another example, a first type feedback signal, which may be a PMI, may be attached with an EC, which may be a CRC, such as a 24 bit CRC. A second type feedback signal may be attached with a second EC, may be a 16 bit CRC.

[0084] In general, different error checking and/or correction can be used for different types feedback signals or different feedback signals of the same type. The choice of which error checking and/or correction to use may involve a design decision of robustness versus overhead. A longer CRC may give greater protection, but it also creates more bits. Therefore, if one type feedback signal is more important than another type feedback signal, a stronger error checking and/or correction capability can be provided to the more important type feedback signal. Similarly for the feedback signal of the same type if one feedback signal or group of feedback signals is more important than another feedback signal or group of feedback signals, a stronger error checking and/or correction capability can be provided to the more important feedback signal or group of feedback signals.

[0085] Referring again to the examples provided above, if the first feedback signal, which may be PMI, is more important than the second feedback signal, which may be a CQI, then a longer CRC with higher error check and detection ability can be used for PMI and shorter CRC with lower error check and detection ability can be used for CQI.

[0086] Applying different error checking and/or correction capabilities to feedback signals can protect the feedback signal that are of importance, optimize the link performance and minimize the signaling overhead.

[0087] Figure 9 is a block diagram 900 of PMI feedback with error checking and correction and channel quality index (CQI) feedback with error checking and

2012203494 15 Jun 2012

correction in accordance with yet another alternative embodiment. A first EC 930 (e.g., CRC) is attached to PMI_1 902 PMI_2 904, PMI_3 906 through PMI_N 908. A second EC 940 (e.g., CRC) is attached to CQI-1 912 through CQI-M 914. The EC attached PMI signal 910 and the CQI signal 920 are coded together in the channel coding function 950 to produce a single transmit signal.

[0088] In Figure 9 the first EC 930 and the second EC 940 may be the same. This would give equal error checking and protection to each feedback signal.

[0089] Alternatively, the first EC 930 and the second EC 940 may be different. If the PMI feedback is more important to system performance than the CQI feedback, the first EC 930 may be more robust. For example, the first EC may be a 24-bit CRC and the second EC may be a 16-bit CRC.

[0090] PMI feedback signals can consist of a "wideband" PMI, "narrowband" PMI, "sub-band" PMI, and/or averaged PMI. Similarly CQI feedback signals can consists of a "wideband" CQI, "narrowband" CQI, "sub-band" CQI and/or averaged CQI.

Also, similar to the embodiments including a single feedback, as shown in Figure 3 through Figure 8, the EC bits and the feedback bits may be transmitted in a single TTI, or may be split in to multiple TTIs. More specifically, the data type channels (e.g., PUSCH) may be used to transmit the feedback bits and the EC bits in a single TTI, as the data type channel is able to handle a greater number of bits per TTI.

[0091] Also, the coding used for the feedback bits and the EC bits may be the same with the same or different weights, or may be different. One skilled in the art would recognize that there numerous possible combinations of coding, transmitting, and error checking.

[0092] Figure 10 is a block diagram 1000 of PMI and CQI feedback in accordance with yet another embodiment. The feedback signals may be attached with error check bits together and coded together. Signals that include PMI_1 1002 through PMI_N 1004 are input into an EC attachment/insertion function 1020 along with signals that include CQI_1 1012 through CQI_M 1014. The

2012203494 15 Jun 2012

signals are processed by the EC function 1020 and a single output signal is input into a channel coding function 1030 prior to transmission.

[0093] Control signaling other than CQI may be used as well, including rank and ACK/NACK.

[0094] Figure 11 is a block diagram 1100 of PMI feedback with error checking and correction, CQI feedback with error checking and correction and ACK/NACK feedback in accordance with yet another embodiment. A first EC 1110 is attached to PMI_1 1102 through PMI_N 1104. A second EC 1120 is attached to CQI_1 1112 through CQI_M 1114. The PMI signal 1106 and the CQI signal 1116 are input into a channel coding function 1140 with an ACK/NACK signal 1130.

[0095] ACK/NACK feedback signal 1130 can be replaced with rank feedback signal in Figure 12. Alternatively rank feedback signal can be added to Figure 12.

[0096] Figure 12 is a block diagram 1200 of PMI feedback and CQI feedback with ACK/NACK feedback in accordance with yet another embodiment. CQI, PMI and ACK/NACK may be coded together, but error checked separately. A PMI signal 1202 including PMI_1 1204 through PMI_N 1206, a CQI signal 1212 including CQI_1 1214 through CQI_M 1216 and an ACK/NACK signal 1220 are input into an EC attachment/insertion function 1230. The single signal output is processed by a channel coding function 1240 and transmitted. One EC (e.g., CRC) is attached to the combined signal prior to coding and transmission.

[0097] ACK/NACK feedback signal 1220 can be replaced with rank feedback signal in Figure 12. Alternatively rank feedback signal can be added to Figure 12.

[0098] The PMI, CQI and ACK/NACK signals may have different error checking and/or protection. For example PMI may have the highest error checking and/or error protection, while CQI may have lower error checking and/or error protection. PMI, CQI, and ACK/NACK can have different error checking and/or protection while using different error checking and/or coding schemes or using the same error checking and/or coding scheme. Different

2012203494 15 Jun 2012

weights may be used on PMI, CQI and ACK/NACK signals. The different error checking and/or error protection may be achieved by using different error checking and/or coding schemes, or using the same error checking and/or coding scheme but with different importance weights on different feedback type signals by using unequal error checking and/or coding and protection schemes. This may be applicable to other feedback signaling, such as rank, for example.

[0099] Similarly PMI feedback signals can consist of a "wideband" PMI, "narrowband" PMI, "sub-band" PMI and/or averaged PMI. Similarly CQI feedback signals can consists of a "wideband" CQI, "narrowband" CQI, "sub-band" CQI and/or averaged CQI.

[00100] EMBODIMENTS

[00101] 1. A method of feedback in a wireless transmit receive unit (WTRU), the method comprising providing a precoding matrix index (PMI); error checking the PMI to produce an error check (EC) bit; coding the PMI and the EC bit; and transmitting the coded PMI and EC bit.

[00102] 2. The method as in embodiment 1 further comprising grouping a plurality of PMIs into PMI groups.

[00103] 3. The method as in embodiment 1 or 2 further comprising error checking each of the plurality of PMI groups to produce the EC bit.

[00104] 4. The method as in any one of embodiments 2 or 3 further comprising error checking each of the plurality of PMI groups to produce a plurality of EC bits, wherein one of the plurality of EC bits is attached to each PMI group; and coding the attached EC bit with the corresponding PMI group.

[00105] 5. The method as in any one of embodiments 2-4 further comprising error checking each of the plurality of PMI groups to produce a plurality of EC bits, wherein one of the plurality of EC bits is attached to each PMI group; and coding the EC bits after coding the PMI groups.

[00106] 6. The method as in embodiment 4 or 5 further comprising providing a plurality of coding functions, wherein each of the plurality of coding functions is associated with one of the plurality of PMI groups; and coding each of

2012203494 15 Jun 2012

- the plurality of PMI groups and associated EC bits with an associated coding function.
- [00107] 7. The method as in any one of embodiments 3-6 wherein a number of PMI groups is equal to a number of EC bits.
- [00108] 8. The method as in any one of embodiments 3-7 further comprising error checking each PMI group individually; and coding the plurality of PMI groups with the EC bits.
- [00109] 9. The method as in any one of embodiment 3-8 further comprising error checking each PMI group individually, and coding the plurality of PMI groups separately from the EC bits.
- [00110] 10. The method as in any one of embodiments 1-9 further comprising providing a control index; error checking the control index to produce a second EC bit; and coding the PMI and the EC bit with the control index and the second EC bit.
- [00111] 11. The method as in embodiment 10 further comprising providing a error detection signal; and coding the PMI, the control index, the EC bit, the second EC bit and the error detection signal.
- [00112] 12. The method as in embodiment 11 wherein the error detection signal is an acknowledge/non-acknowledge (ACK/NACK) signal.
- [00113] 13. A method for feedback in a wireless transmit receive unit (WTRU), the method comprising providing a precoding matrix index (PMI); providing a control index; error checking the PMI and the control index to produce an error checking (EC) bit; and coding the PMI, the control index and EC bit.
- [00114] 14. The method as in embodiment 13 further comprising transmitting the coded PMI, control index and EC bit to a base station.
- [00115] 15. The method as in embodiment 13 or 14 wherein the control index is a channel quality index (CQI).
- [00116] 16. A wireless transmit/receive unit (WTRU) comprising a processor configured to determine a precoding matrix index (PMI); error check

2012203494 15 Jun 2012

the (PMI) to produce an error check (EC) bit; and code the PMI and the EC bit; and a transmitter configured to transmit the coded PMI and EC bit.

[00117] 17. The WTRU as in embodiment 16 wherein the processor is further configured to group a plurality of PMIs into PMI groups.

[00118] 18. The WTRU as in embodiment 17 wherein the processor is further configured to error check each of the plurality of PMI groups to produce the EC bit.

[00119] 19. The WTRU as in embodiment 17 or 18 wherein the processor is further configured to error check each of the plurality of PMI groups to produce a plurality of EC bits, wherein one of the plurality of EC bits is attached to each PMI group; and code the attached EC bit with the corresponding PMI group.

[00120] 20. The WTRU as in any one of embodiments 17-19 wherein the processor is further configured to error check each of the plurality of PMI groups to produce a plurality of EC bits, wherein one of the plurality of EC bits is attached to each PMI group; and code the EC bits after coding the PMI groups

[00121] 21. The WTRU as in embodiment 20 or 21 wherein the processor is further configured to determine a plurality of coding functions, wherein each of the plurality of coding functions is associated with one of the plurality of PMI groups; and code each of the plurality of PMI groups and associated EC bits with an associated coding function.

[00122] 22. The WTRU as in any one of embodiments 19-21 wherein a number of PMI groups is equal to a number of EC bits.

[00123] 23. The WTRU as in any one of embodiments 19-22 wherein the processor is further configured to error check each PMI group individually; and code the plurality of PMI groups with the EC bits.

[00124] 24. The WTRU as in any one of embodiments 19-23 wherein the processor is further configured to error check each PMI group individually, and code the plurality of PMI groups separately from the EC bits.

[00125] 25. The WTRU as in any one of embodiments 16-23 wherein the processor is further configured to determine a control index; error check the

2012203494 15 Jun 2012

- control index to produce a second EC bit; and code the PMI and the EC bit with the control index and the second EC bit.
- [00126] 26. The WTRU as in embodiment 25 wherein the processor is further configured to determine a error detection signal; and code the PMI, the control index, the EC bit, the second EC bit and the error detection signal.
- [00127] 27. The WTRU as in embodiment 25 or 26 wherein the error detection signal is an acknowledge/non-acknowledge (ACK/NACK) signal.
- [00128] 28. A method of feedback in a wireless transmit receive unit (WTRU), the method comprising providing a feedback bit error checking the feedback bit to produce an error check (EC) bit coding the feedback bit and the EC bit and transmitting the coded feedback bit and EC bit.
- [00129] 29. The method as in embodiment 28 further comprising grouping a plurality of feedback bits into feedback groups.
- [00130] 30. The method as in embodiment 28 or 29 further comprising error checking each of the plurality of feedback groups to produce the EC bit.
- [00131] 31. The method as in any one of embodiments 28-30 wherein the feedback bit comprises a precoding matrix index (PMI).
- [00132] 32. The method as in any one of embodiments 28-31 wherein the feedback bit comprises a channel quality index (CQI).
- [00133] 33. The method as in any one of embodiments 28-32 wherein the feedback bit comprises a rank.
- [00134] 34. The method as in any one of embodiments 28-33 wherein the feedback bit comprises an acknowledge/non-acknowledge (ACK/NACK).
- [00135] 35. The method as in any one of embodiments 28-34 wherein the EC bit comprises a cyclic redundancy check (CRC).
- [00136] 36. The method as in any one of embodiments 28-35 further comprising coding the EC bit with the feedback bit.
- [00137] 37. The method as in any one of embodiments 28-36 further comprising coding the EC bit separate from the EC bit.

2012203494 15 Jun 2012

9

[00138] 38. The method as in any one of embodiments 28-37 further comprising transmitting the feedback bit and the EC bit in a single transmission time interval (TTI)

[00139] 39. The method as in any one of embodiments 28-38 further comprising transmitting the feedback bit and the EC bit in separate TTIs.

[00140] 40. The method as in any one of embodiments 28-39 further comprising transmitting the feedback bit and a portion of the EC bit in a single TTI.

[00141] 41. The method as in any one of embodiments 29-40 further comprising error checking each of the plurality of feedback groups to produce a plurality of EC bits, wherein one of the plurality of EC bits is attached to each feedback group; and coding the EC bits after coding the feedback groups.

[00142] 42. The method as in embodiment 41 further comprising providing a plurality of coding functions, wherein each of the plurality of coding functions is associated with one of the plurality of feedback groups; and coding each of the plurality of the feedback groups and associated EC bits with an associated coding function.

[00143] Although features and elements are described above in particular combinations, each feature or element can be used alone without the other features and elements or in various combinations with or without other features and elements. The methods or flow charts provided herein may be implemented in a computer program, software, or firmware incorporated in a computer-readable storage medium for execution by a general purpose computer or a processor. Examples of computer-readable storage mediums include a read only memory (ROM), a random access memory (RAM), a register, cache memory, semiconductor memory devices, magnetic media such as internal hard disks and removable disks, magneto-optical media, and optical media such as CD-ROM disks, and digital versatile disks (DVDs).

[00144] Suitable processors include, by way of example, a general purpose processor, a special purpose processor, a conventional processor, a digital signal processor (DSP), a plurality of microprocessors, one or more microprocessors in

2012203494 15 Jun 2012

association with a DSP core, a controller, a microcontroller, Application Specific Integrated Circuits (ASICs), Field Programmable Gate Arrays (FPGAs) circuits, any other type of integrated circuit (IC), and/or a state machine.

[00145] A processor in association with software may be used to implement a radio frequency transceiver for use in a wireless transmit receive unit (WTRU), user equipment (UE), terminal, base station, radio network controller (RNC), or any host computer. The WTRU may be used in conjunction with modules, implemented in hardware and/or software, such as a camera, a video camera module, a videophone, a speakerphone, a vibration device, a speaker, a microphone, a television transceiver, a hands free headset, a keyboard, a Bluetooth® module, a frequency modulated (FM) radio unit, a liquid crystal display (LCD) display unit, an organic light-emitting diode (OLED) display unit, a digital music player, a media player, a video game player module, an Internet browser, and/or any wireless local area network (WLAN) or Ultra Wide Band (UWB) module.

* * *

THE CLAIMS DEFINING THE INVENTION ARE AS FOLLOWS:

1. A method of feedback in a wireless transmit receive unit (WTRU), the method including:
 - the WTRU generating a feedback signal, the feedback signal including at least one of a precoding matrix index (PMI) or a channel quality index (CQI);
 - the WTRU determining a number of bits of the feedback signal to be encoded;
 - the WTRU selecting a type of error detection and correction scheme to apply to the feedback signal based on the number of bits of the feedback signal to be encoded, wherein selecting the type of error detection and correction scheme includes selecting a number of error check (EC) bits to attach to the feedback signal and selecting a type of channel coding scheme to apply to the feedback signal and the selected number of EC bits;
 - the WTRU encoding the feedback signal and the selected number of EC bits using the selected type of channel coding scheme; and
 - the WTRU transmitting the encoded feedback signal.
2. The method as in claim 1, wherein the error detection mechanism of the error detection and correction scheme is disabled, and the number of EC bits is selected to be zero.
3. The method as in claim 1, wherein the number of EC bits includes a number of cyclic redundancy check bits.
4. The method as in claim 1, wherein the encoded feedback signal is transmitted over a data-type channel.
5. The method as in claim 4, wherein the encoded feedback signal is transmitted over the data-type channel with turbo coded user data bits.
6. The method as in claim 5, wherein the data-type channel is a physical uplink shared channel (PUSCH).

7. A wireless transmit receive unit (WTRU) including a processor configured, at least in part, to:

generate a feedback signal, the feedback signal including at least one of a precoding matrix index (PMI) or a channel quality index (CQI);

determine a number of bits of the feedback signal to be encoded;

select a type of error detection and correction scheme to apply to the feedback signal based on the number of bits of the feedback signal to be encoded, wherein the processor is configured to select the type of error detection and correction scheme by selecting a number of error check (EC) bits to attach to the feedback signal and by selecting a type of channel coding scheme to apply to the feedback signal and the selected number of EC bits;

encode the feedback signal and the selected number of EC bits using the selected type of channel coding scheme; and

transmit the encoded feedback signal.

8. The WTRU as in claim 7, wherein the processor is configured to determine to disable the error detection mechanism of the error detection and correction scheme such that the number of EC bits to attach to the feedback signal is selected to be zero.

9. The WTRU as in claim 7, wherein the selected type of channel coding scheme includes a convolutional coding scheme.

10. The WTRU as in claim 9, wherein the selected number of EC bits includes a selected number of cyclic redundancy check (CRC) bits.

11. The WTRU as in claim 7, wherein the processor is configured to transmit a rank indicator with the encoded feedback signal.

12. The WTRU as in claim 11, wherein the processor is configured to transmit a hybrid automatic repeat request (HARQ) acknowledgement/negative acknowledgment (ACK/NACK) with the encoded feedback signal.

13. The WTRU as in claim 7, wherein the feedback signal includes a first group of PMIs, the processor is configured to transmit the encoded feedback signal in a first transmission time interval (TTI), a second feedback signal includes a second group of PMIs, and the processor is configured to transmit an encoded instance of the second feedback signal in a second TTI.

14. The WTRU as in claim 13, wherein the processor is configured to select a second type of error detection and correction scheme to apply to the second feedback signal based on the number of bits of the second feedback signal.

15. The WTRU as in claim 13, wherein the second error detection and correction scheme is selected to be the same error detection and correction scheme as was selected for the feedback signal.

16. A method for a wireless transmit receive unit (WTRU), the method including:

the WTRU determining to transmit a first feedback signal in a first transmission time interval (TTI), wherein the first feedback signal includes a first group of precoding matrix indices (PMIs);

the WTRU selecting a first type of error detection and correction scheme to apply to the first feedback signal based on a number of bits of the first feedback signal to be encoded, wherein selecting the first type of error detection and correction scheme to apply to the first feedback signal includes selecting a number of cyclic redundancy check (CRC) bits to attach to the first feedback signal and selecting a type of channel coding scheme to apply to the first feedback signal and the selected number of CRC bits;

the WTRU applying the first type of error detection and correction scheme to the first feedback signal;

the WTRU transmitting the encoded first feedback signal in the first TTI after applying the first type of error detection and correction scheme;

the WTRU determining to transmit a second feedback signal in a second TTI, wherein the second feedback signal includes a second group of precoding matrix indices (PMIs);

the WTRU selecting a second type of error detection and correction scheme to apply to the second feedback signal based on a number of bits of the second feedback signal to be encoded;

the WTRU applying the second type of error detection and correction scheme to the second feedback signal; and

the WTRU transmitting the encoded second feedback signal in the second TTI after applying the second type of error detection and correction scheme.

17. A wireless transmit receive unit (WTRU) including a processor configured, at least in part, to:

generate a feedback signal, the feedback signal including at least one of a precoding matrix index (PMI) or a channel quality index (CQI);

determine a number of bits of the feedback signal to be encoded;

select a number of error check (EC) bits to attach to the feedback signal based on the number of bits of the feedback signal to be encoded;

selecting a type of channel coding scheme to apply to the feedback signal and the selected number of EC bits based on the number of bits of the feedback signal to be encoded;

encode the feedback signal and the selected number of EC bits using the selected type of channel coding scheme; and

transmit the encoded feedback signal.

18. The WTRU as in claim 24, wherein zero EC bits are selected for attachment to the first feedback signal.

19. The WTRU as in claim 24, wherein the number of EC bits include a number of cyclic redundancy check (CRC) bits.

20. The method as in claim 1, and substantially as hereinbefore described with reference to the accompanying figures.

21. The WTRU as in claim 7, and substantially as hereinbefore described with reference to the accompanying figures.
22. The method as in claim 16, and substantially as hereinbefore described with reference to the accompanying figures.
23. The WTRU as in claim 17, and substantially as hereinbefore described with reference to the accompanying figures.

INTERDIGITAL TECHNOLOGY CORPORATION

WATERMARK PATENT AND TRADE MARKS ATTORNEYS

P32540AU01

2012203494 15 Jun 2012

1/6

100

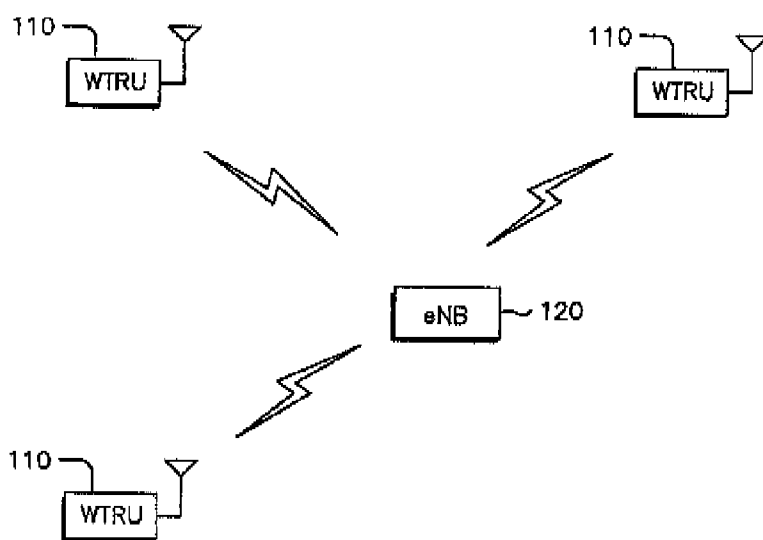

FIG. 1

2012203494 15 Jun 2012

200

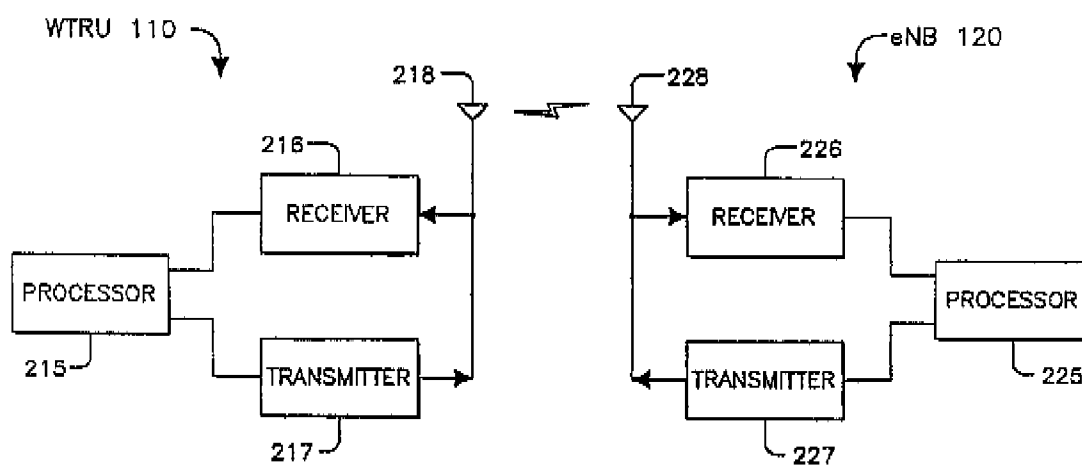
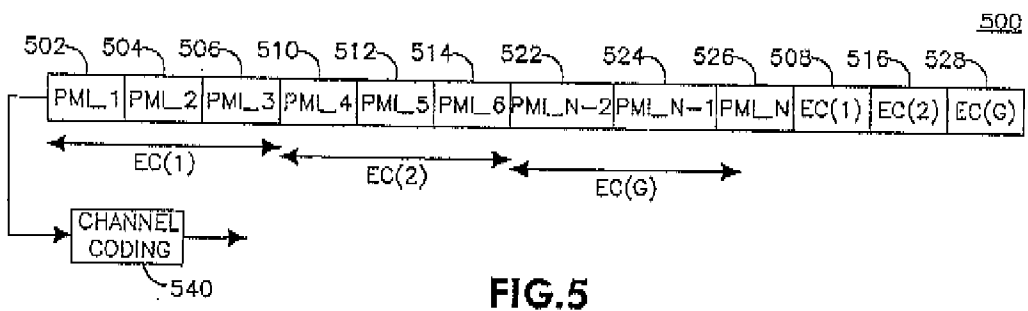
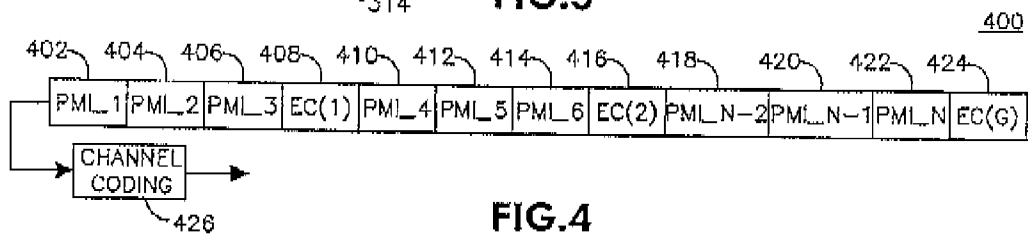
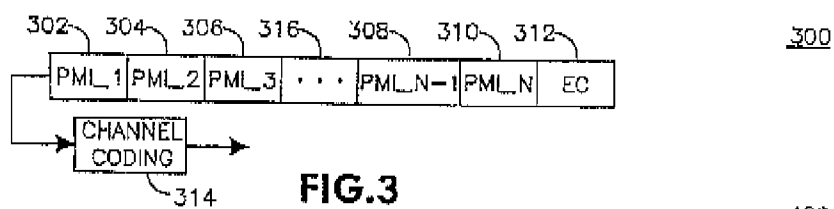

FIG.2

2012203494 15 Jun 2012



2012203494 15 Jun 2012

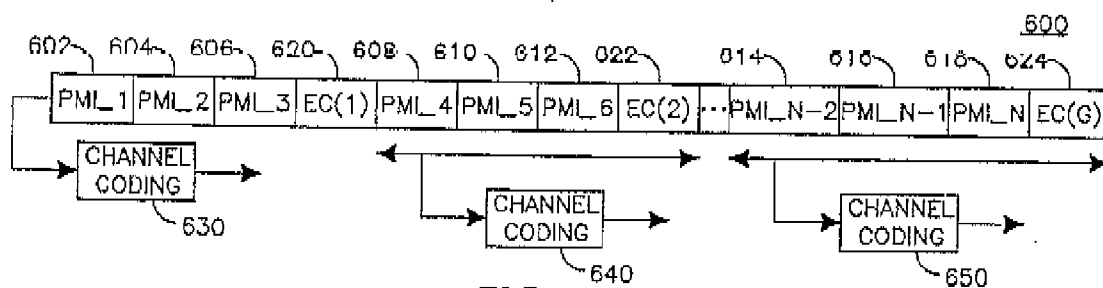

FIG. 6

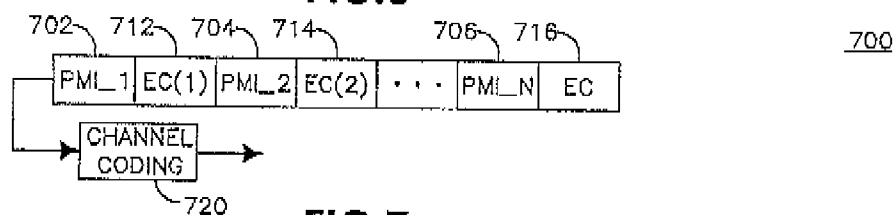

FIG. 7

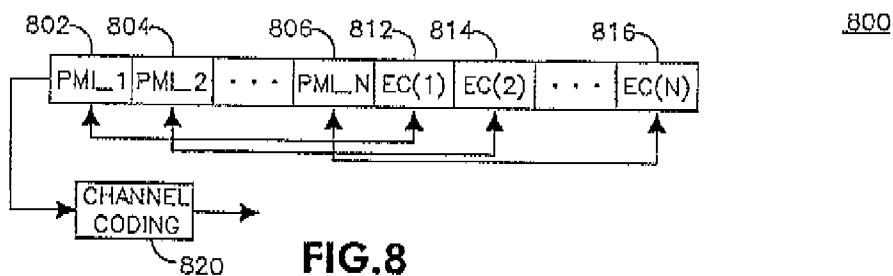

FIG. 8

2012203494 15 Jun 2012

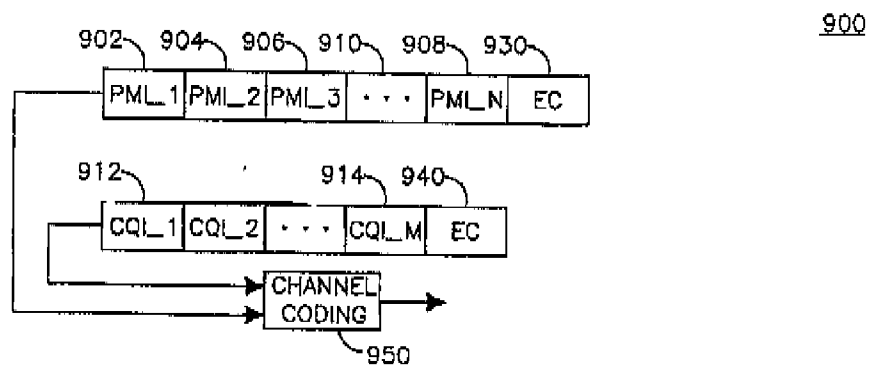

FIG. 9

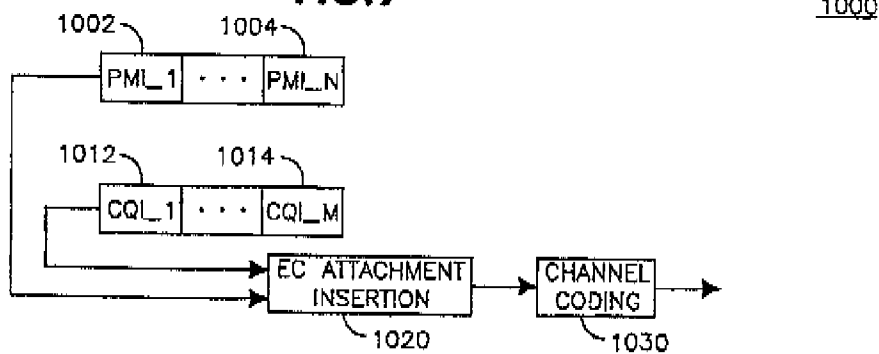

FIG. 10

2012203494 15 Jun 2012

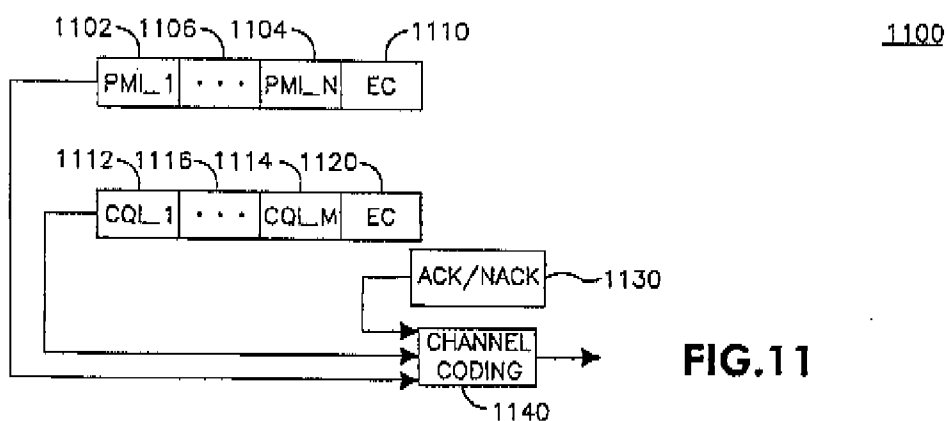

FIG. 11

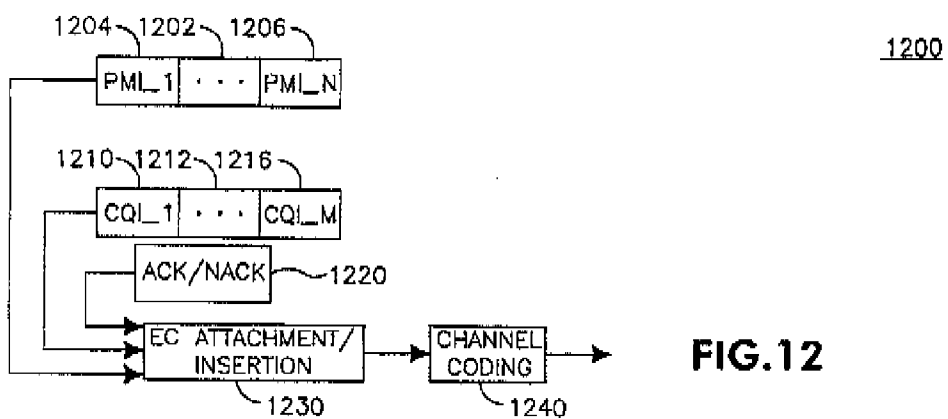

FIG. 12