



US00D902257S

(12) **United States Design Patent**
Whittle

(10) **Patent No.:** **US D902,257 S**

(45) **Date of Patent:** **** Nov. 17, 2020**

(54) **ELECTRONICS FUEL INJECTION THROTTLE BODY**

5,261,382 A	11/1993	Nikolai
D447,147 S	8/2001	Grant
6,481,698 B1	11/2002	Calvin et al.
D508,496 S	8/2005	Grant
D543,555 S	5/2007	Braswell et al.
D555,668 S	11/2007	Benoit

(Continued)

(71) Applicant: **Holley Performance Products, Inc.**,
Bowling Green, KY (US)

(72) Inventor: **Gregory Whittle**, Bowling Green, KY (US)

(73) Assignee: **Holley Performance Products, Inc.**,
Bowling Green, KY (US)

AU	339157	10/2011
AU	341133	2/2012

(Continued)

(**) Term: **15 Years**

(21) Appl. No.: **29/647,060**

(22) Filed: **May 9, 2018**

(51) **LOC (12) Cl.** **15-01**

(52) **U.S. Cl.**
USPC **D15/6**

(58) **Field of Classification Search**
USPC D15/1-6
CPC F02M 69/52; F02M 69/043; F02M 69/462;
F02M 69/54; F02M 63/0056; F02M 63/02; F02M 51/005; F02M 51/02; F02M 69/04; F02D 9/1035; F02D 9/105; F02D 11/10

See application file for complete search history.

(56) **References Cited**

U.S. PATENT DOCUMENTS

4,224,908 A	9/1980	Bier et al.
4,230,645 A	10/1980	Dodson
4,246,875 A	1/1981	Bier et al.
4,294,282 A	10/1981	McCabe et al.
4,306,441 A	12/1981	Dodson
4,318,214 A	3/1982	Dodson
4,325,339 A	4/1982	Bier et al.
4,357,283 A	11/1982	Manning
4,434,762 A	3/1984	McCabe
4,434,763 A	3/1984	McCabe et al.
4,556,032 A	12/1985	Miller
4,949,983 A	8/1990	Miller

FOREIGN PATENT DOCUMENTS

OTHER PUBLICATIONS

U.S. Appl. No. 29/688,819 entitled "Electronic Fuel Injection Throttle Body" filed Apr. 24, 2019.

(Continued)

Primary Examiner — Ania Aman

(74) *Attorney, Agent, or Firm* — Middleton Reutlinger

(57) **CLAIM**

The ornamental design for an electronic fuel injection throttle body, as shown and described.

DESCRIPTION

FIG. 1 is a first perspective view of an electronic fuel injection throttle showing my new design; FIG. 2 is a second perspective of the design of FIG. 1; FIG. 3 is a front view of the design of FIG. 1; FIG. 4 is a rear view of the design of FIG. 1; FIG. 5 is a top view of the design of FIG. 1; FIG. 6 is a bottom view of the design of FIG. 1; FIG. 7 is a right side of the design of FIG. 1; and, FIG. 8 is a left side view of the design of FIG. 1. The broken lines shown in the drawings are for the purpose of illustrating portions of the article and form no part of the claimed design.

1 Claim, 8 Drawing Sheets

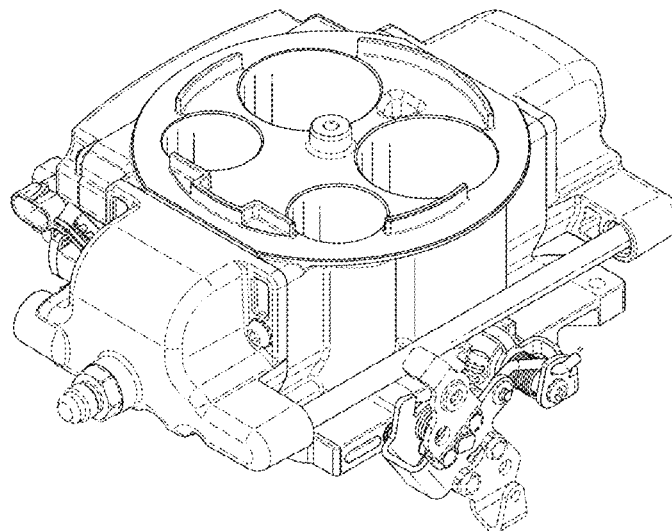

(56)

References Cited

U.S. PATENT DOCUMENTS

D578,550	S	10/2008	Benoit	
7,533,661	B2	5/2009	Baasch	
7,591,245	B2	9/2009	Baasch et al.	
D645,058	S	9/2011	Benoit	
D648,746	S	11/2011	Tipton et al.	
D655,311	S	3/2012	Gieske et al.	
D659,714	S	5/2012	Gieske et al.	
D721,389	S	1/2015	Gieske et al.	
9,115,671	B2	8/2015	Benoit	
9,303,578	B2	4/2016	Wittkopf et al.	
9,376,997	B1	6/2016	Farrell et al.	
D760,804	S	7/2016	Shehan et al.	
9,482,198	B1	11/2016	Farrell et al.	
9,845,740	B2	12/2017	Wittkopf et al.	
D808,435	S	1/2018	Shehan et al.	
D810,142	S	2/2018	Shehan et al.	
10,012,197	B2	7/2018	Flynn et al.	
D826,280	S	8/2018	Koo et al.	
10,094,353	B2	10/2018	Bennett et al.	
2008/0230034	A1	9/2008	Dunn	
2009/0013955	A1	1/2009	Sheridan et al.	
2009/0145406	A1	6/2009	Farrell et al.	
2011/0120413	A1*	5/2011	Runia	F02D 9/1035 123/337
2013/0054121	A1	2/2013	Casoni et al.	
2013/0298868	A1*	11/2013	Wittkopf	F02D 41/08 123/339.14
2013/0298871	A1	11/2013	Bennett et al.	
2015/0108256	A1	4/2015	Flynn et al.	
2017/0198672	A1	7/2017	Farrell et al.	
2018/0119656	A1	5/2018	Shehan et al.	

FOREIGN PATENT DOCUMENTS

AU	348732	5/2013
AU	348733	5/2013
AU	348734	5/2013
AU	356762	8/2014
AU	201710470	2/2017
AU	201710471	2/2017
AU	2013254906	11/2017
AU	201813353	8/2018
AU	201813355	8/2018
AU	201815034	9/2018
AU	201815036	9/2018
AU	201816623	12/2018
AU	201816624	12/2018
CA	188483	9/2019
CN	101568711	4/2013
EM	003729599	1/2017

OTHER PUBLICATIONS

U.S. Appl. No. 29/693,670 entitled "Electronic Fuel Injection Throttle Body Assembly" filed Jun. 4, 2019.

U.S. Appl. No. 29/695,154 entitled "EFI Throttle Body Assembly" filed Jun. 17, 2019.

U.S. Appl. No. 29/696,092 entitled "Electronic Fuel Injection Throttle Body" filed Jun. 25, 2019.

U.S. Appl. No. 16/404,308 entitled "Electronic Fuel Injection Throttle Body Assembly" filed May 5, 2019.

U.S. Appl. No. 16/405,519 entitled "Electronic Fuel Injection Throttle Body Assembly" filed May 1, 2019.

U.S. Appl. No. 29/628,392 entitled "EFI Throttle Body" filed Dec. 4, 2017.

Holley Performance Products, Inc., 2017 New & Hot Products Catalogue—Carburetors, Nov. 1, 2016.

U.S. Appl. No. 62/594,526 entitled "Electronic Fuel Injection Throttle Body Assembly" filed Dec. 4, 2017.

Australian Patent Application No. 2017251869 entitled "Electronic Fuel Injection Throttle Body Assembly" filed Oct. 30, 2017.

U.S. Appl. No. 62/594,527 entitled "Electronic Fuel Injection Throttle Body Assembly" filed Dec. 4, 2017.

U.S. Appl. No. 29/628,394 entitled "EFI Throttle Body" filed Dec. 4, 2017.

U.S. Appl. No. 62/669,052 entitled "Electronic Fuel Injection Throttle Body Assembly" filed May 3, 2018.

U.S. Appl. No. 15/986,571 entitled "Fuel Injection Throttle Body" filed May 22, 2018.

U.S. Appl. No. 16/208,246 entitled "Electronic Fuel Injection Throttle Body Assembly" filed Dec. 3, 2018.

U.S. Appl. No. 29/647,068 entitled "Electronic Fuel Injection Throttle Body" filed May 9, 2018.

U.S. Appl. No. 62/669,094 entitled "Electronic Fuel Injection Throttle Body Assembly" filed May 9, 2018.

U.S. Appl. No. 62/726,723 entitled "Electronic Fuel Injection Throttle Body Assembly" filed Sep. 4, 2018.

Mopar Performance P5249686 Jeep MPI-Fuel, Sep. 2, 2016.

Howell EFI Fuel Injection Conversion Kit, JP258, Apr. 29, 2015.

F.A.S.T. EZ-EFI Self-Tuning Fuel Injection Systems 30294-Kit TBI Conversion Kit, Jun. 30, 2015.

U.S. Appl. No. 16/208,231 entitled "Electronic Fuel Injection Throttle Body Assembly" filed Dec. 3, 2018.

International Search Report and Written Opinion for PCT/US2018/063660 dated Mar. 20, 2019.

International Search Report and Written Opinion for PCT/US2018/063668 dated Mar. 20, 2019.

Canadian Design Patent Application No. 184483 entitled "Electronic Fuel Injection Throttle Body" filed Oct. 31, 2018.

Canadian Design Patent Application No. 184482 entitled "Electronic Fuel Injection Throttle Body" filed Oct. 31, 2018.

Mexican Design Patent Application No. MX/f/2018/003332 entitled "Electronic Fuel Injection Throttle Body" filed Nov. 8, 2018.

Mexican Design Patent Application No. MX/f/2018/003333 entitled "Electronic Fuel Injection Throttle Body" filed Nov. 8, 2018.

International Search Report and Written Opinion for PCT/US2019/030909 dated Aug. 20, 2019.

International Search Report and Written Opinion for PCT/US2019/031138 dated Aug. 27, 2019.

Youtube video, "Holley Terminator EFI Kit Electronic Fuel Injection", May 6, 2015. Retrieved from <https://www.youtube.com/watch?v=hrTppUkNAn0>; retrieved on Jul. 1, 2019.

Wikipedia, Quadrajets, Rochester Products spread bore carburetor introduced in 1964, retrieved from internet on Apr. 16, 2019.

* cited by examiner

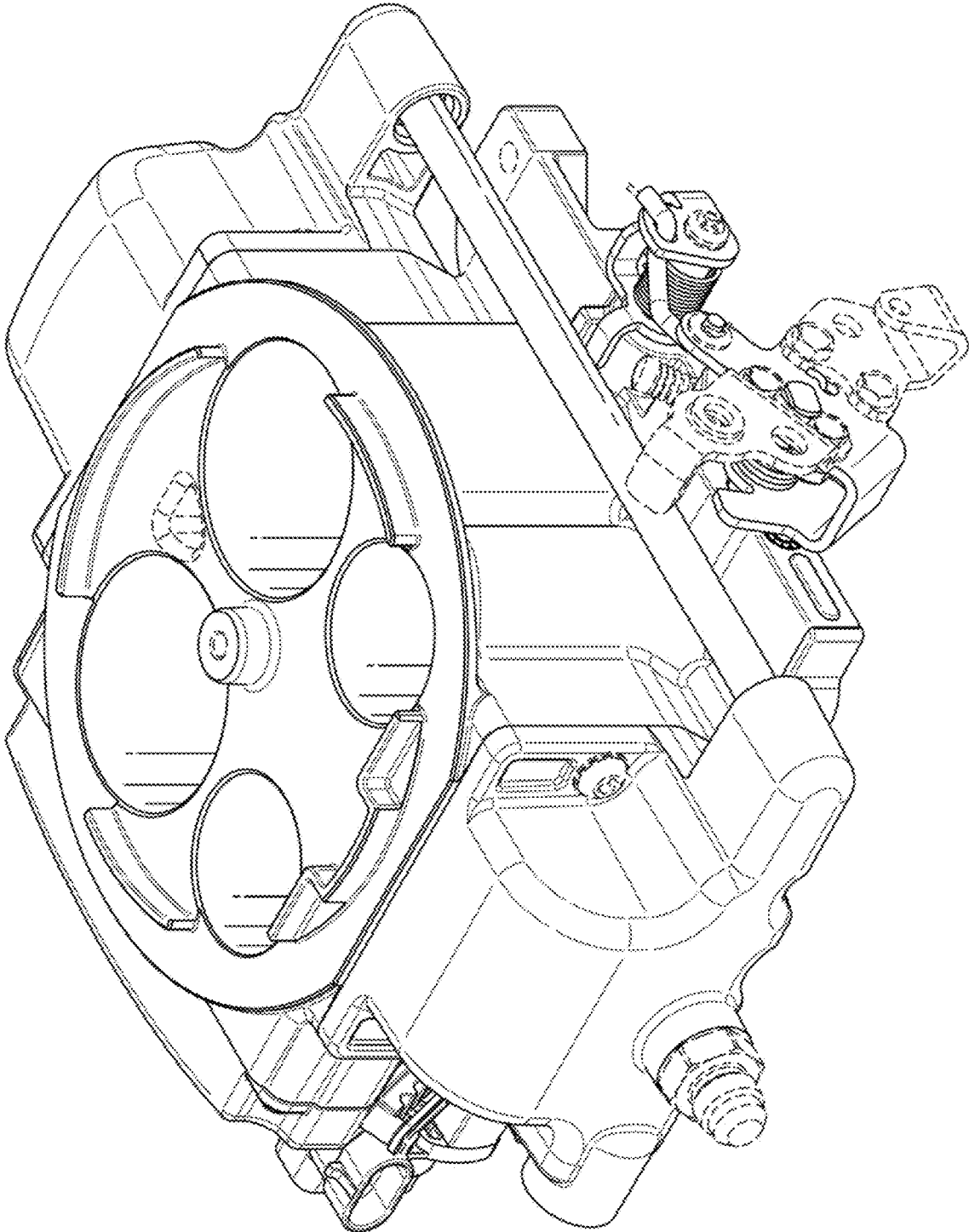

FIG. 1

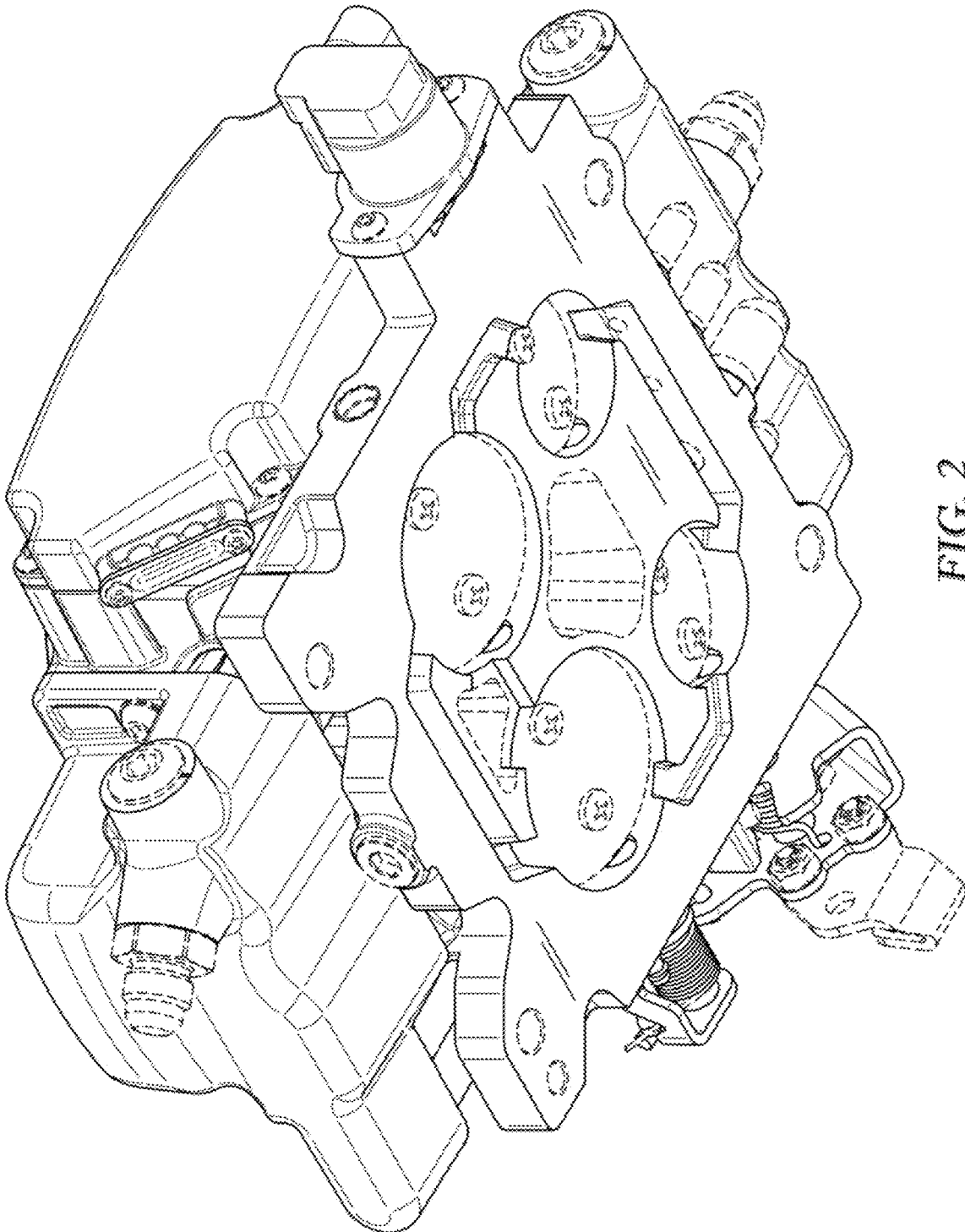

FIG. 2

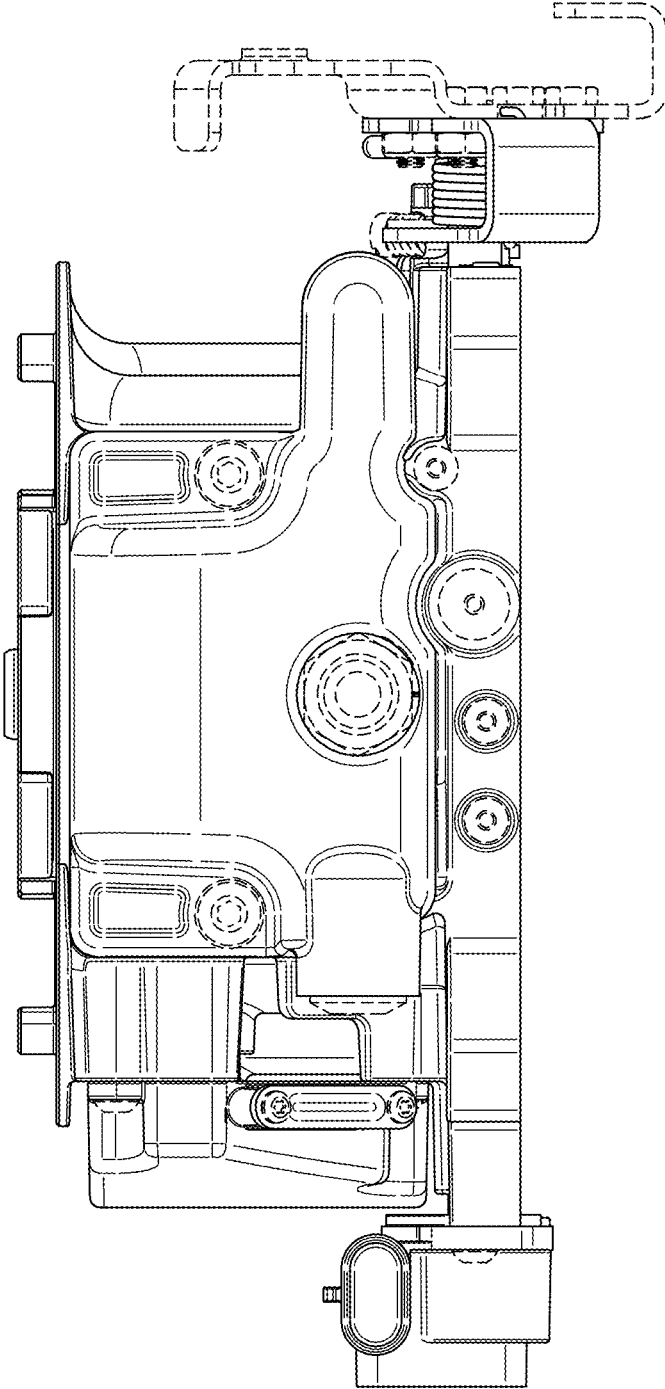

FIG. 3

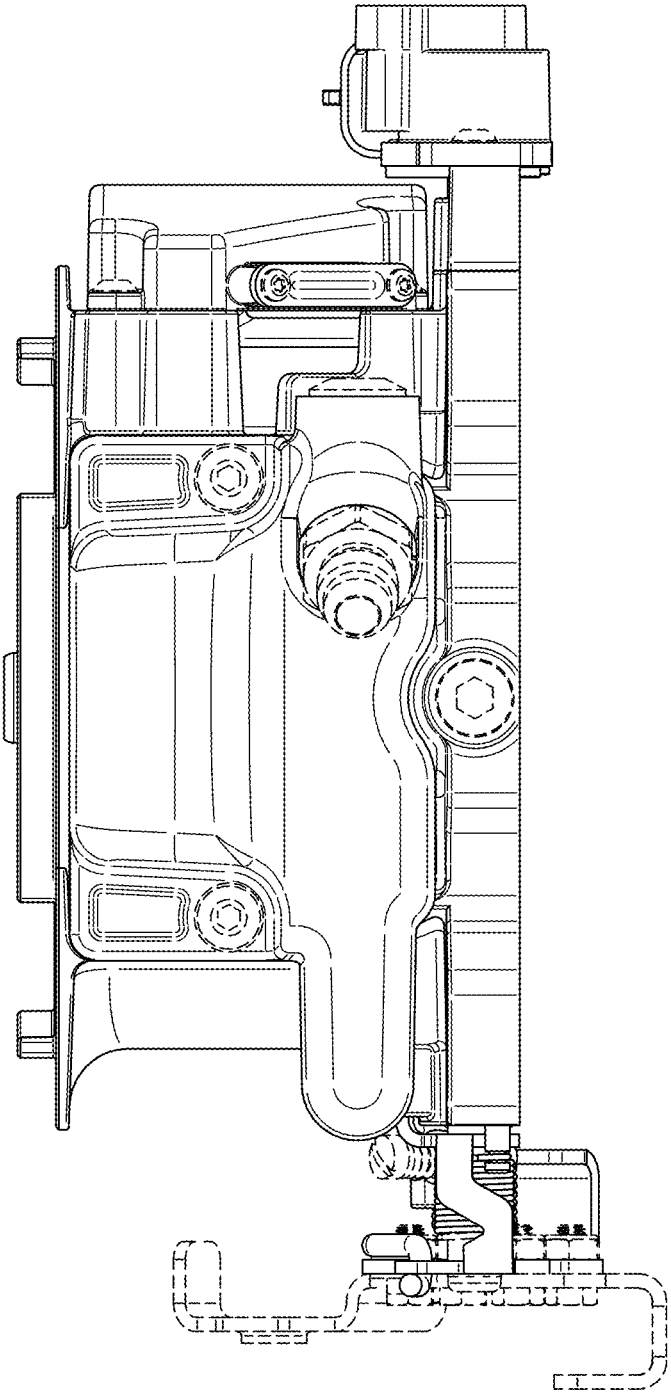

FIG. 4

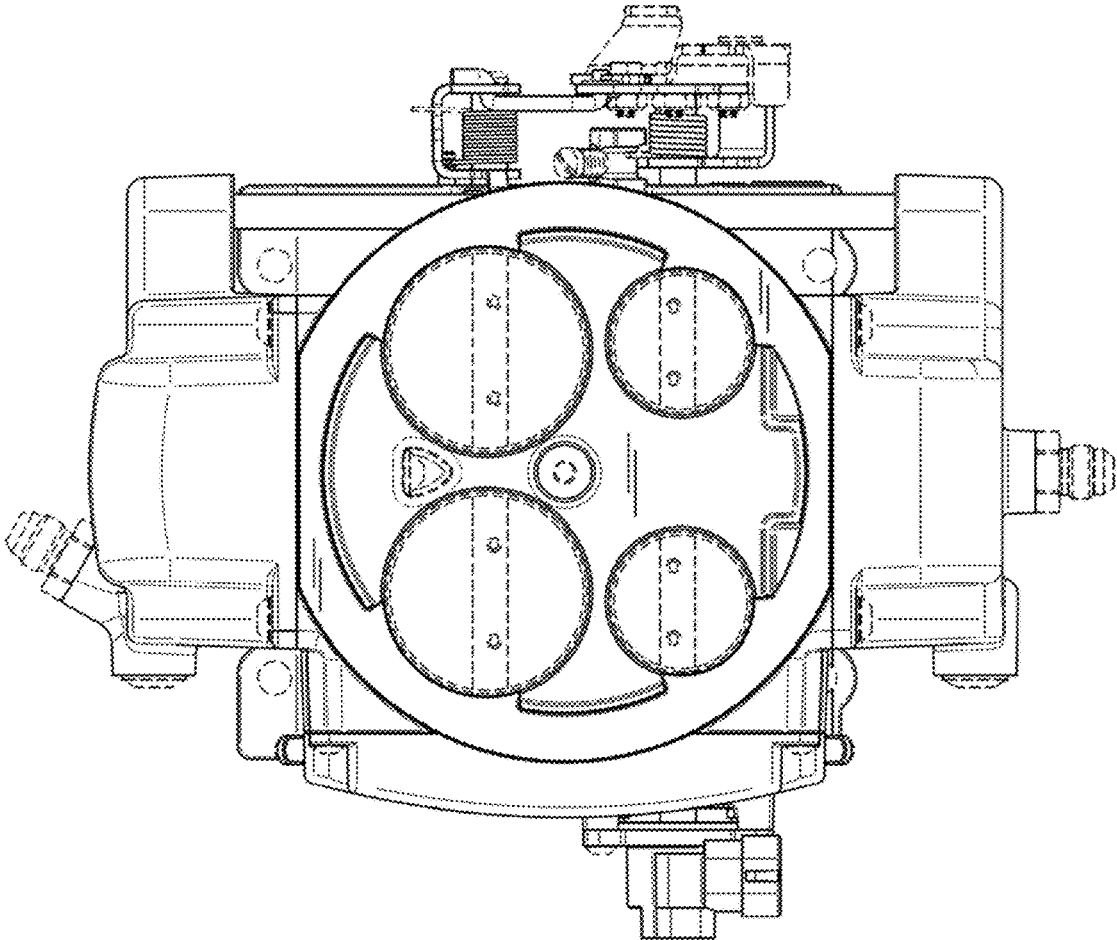

FIG. 5

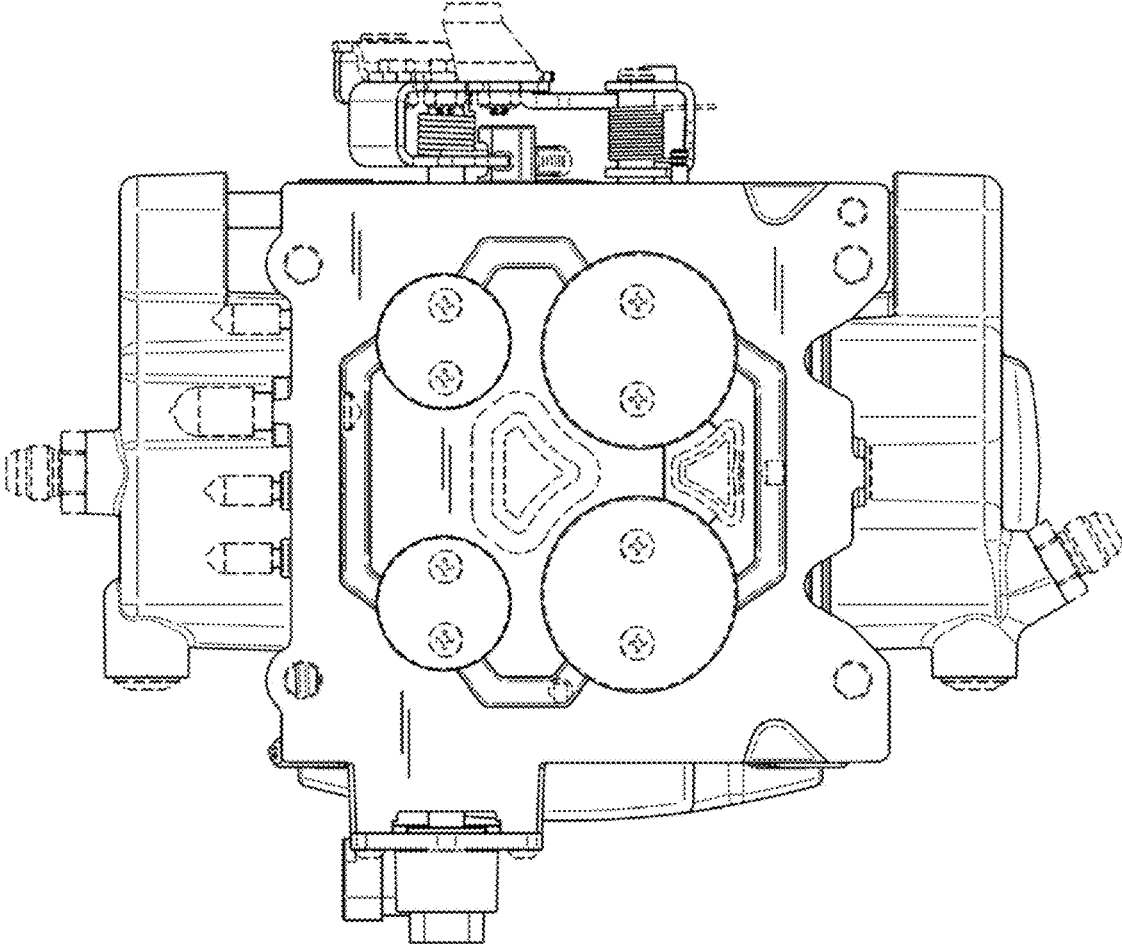

FIG. 6

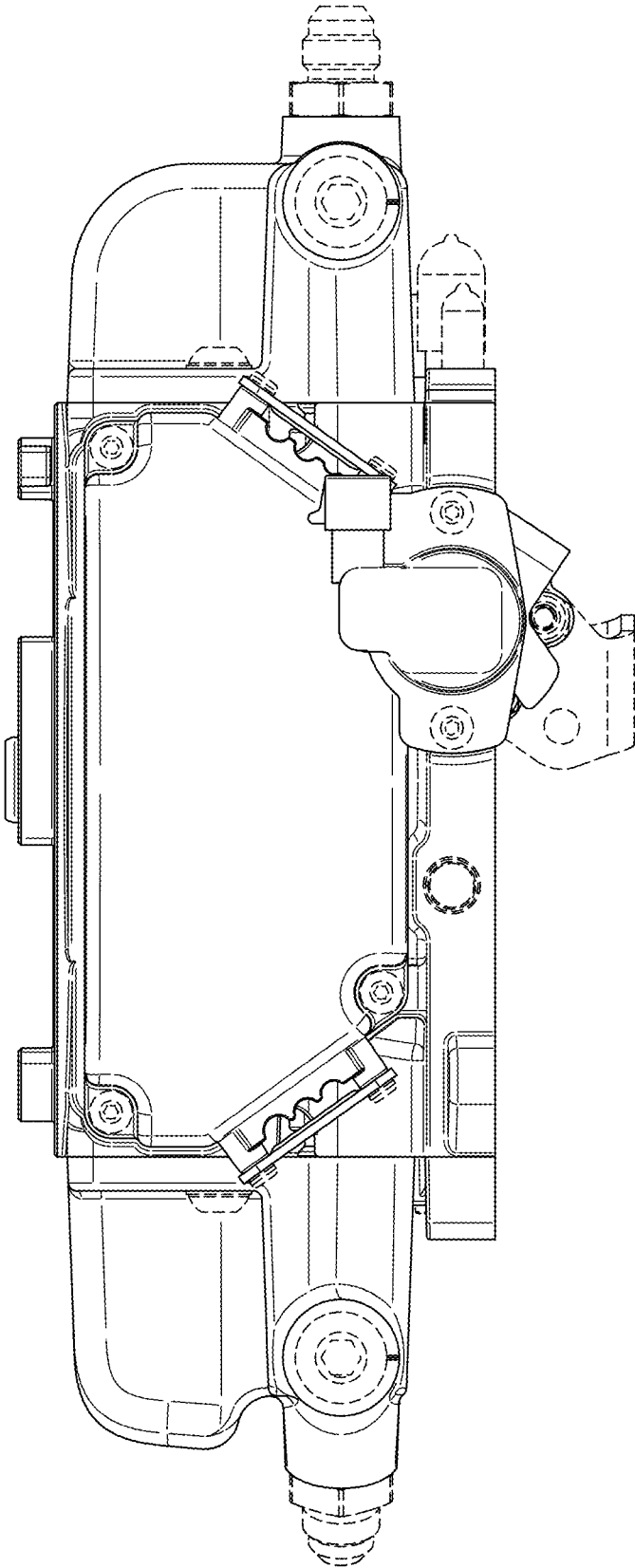

FIG. 7

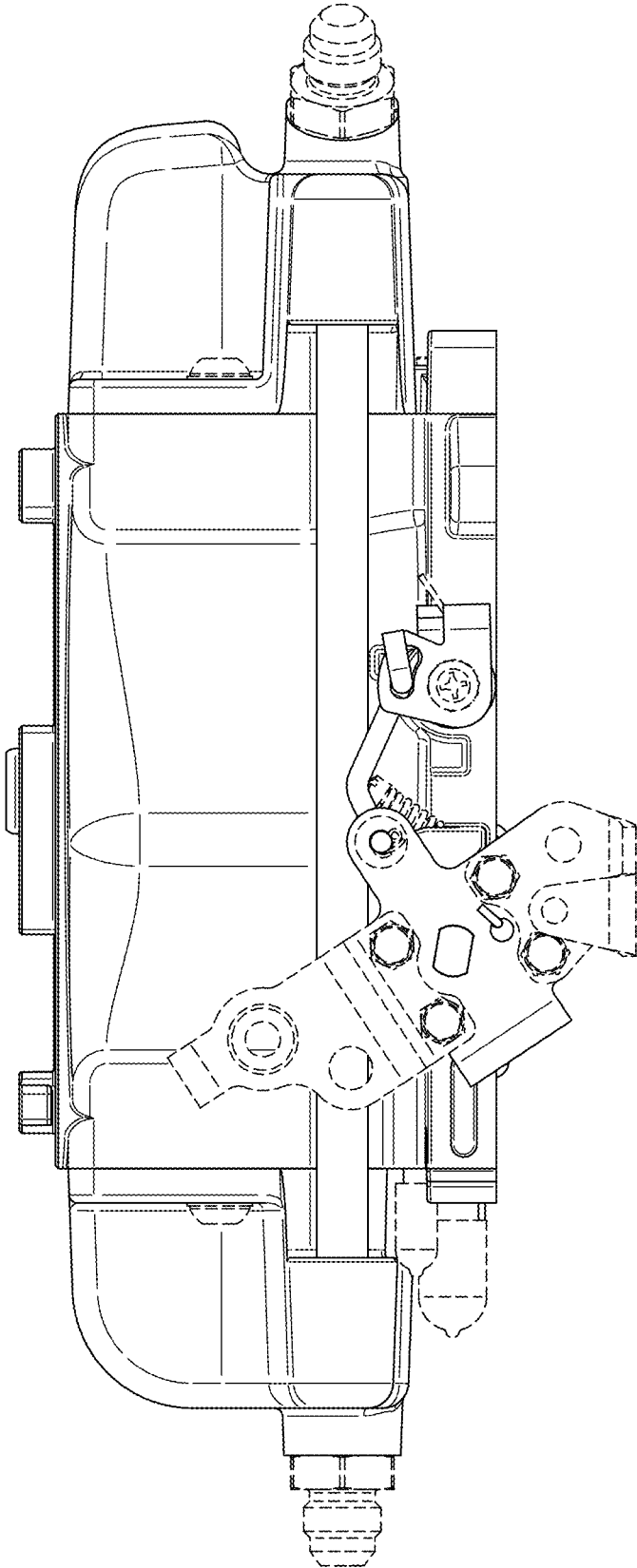

FIG. 8