



US00D914544S

(12) **United States Design Patent**
Sheffield et al.

(10) **Patent No.:** US D914,544 S

(45) **Date of Patent:** ** Mar. 30, 2021

(54) **AUTOMOBILE AND/OR REPLICAS THEREOF**

(71) Applicant: **ASTON MARTIN LAGONDA LIMITED**, Warwick (GB)

(72) Inventors: **Andrew Sheffield**, Warwick (GB);
Tobias Suchlmann, Warwick (GB)

(73) Assignee: **ASTON MARTIN LAGONDA LIMITED**

(**) Term: **15 Years**

(21) Appl. No.: **29/699,560**

(22) Filed: **Jul. 26, 2019**

(30) **Foreign Application Priority Data**

Jan. 31, 2019 (EM) 006137568

(51) **LOC (13) CL.** **12-08**

(52) **U.S. CL.**
USPC **D12/91**

(58) **Field of Classification Search**
USPC D12/86, 90–92, 88; D21/424, 433, 434;
296/181.1–181.5, 183.1

CPC B62D 25/00; B62D 25/06; B62D 33/00;
B62D 35/00

See application file for complete search history.

(56) **References Cited**

U.S. PATENT DOCUMENTS

D620,396 S	7/2010	Reichman et al.
D626,466 S	11/2010	Reichman et al.
D629,718 S	12/2010	Reichman et al.
D629,719 S	12/2010	Reichman et al.
D629,725 S	12/2010	Reichman et al.
D630,140 S	1/2011	Reichman et al.
D670,640 S	11/2012	Reichman et al.
D687,348 S	8/2013	Nurnberger
D689,812 S	9/2013	Reichman et al.

D692,800 S	11/2013	Wiltshire
D704,102 S	5/2014	Nurnberger
D704,601 S	5/2014	Nurnberger
D726,079 S	4/2015	Reichman et al.
D727,804 S	4/2015	Nurnberger
D730,777 S	6/2015	Nurnberger
D739,789 S	9/2015	Payne
D740,725 S	10/2015	Payne
D758,247 S	6/2016	Nurnberger et al.
D766,474 S	9/2016	Holgate et al.
D772,128 S	11/2016	Platt
D774,950 S	12/2016	Holgate et al.
D774,995 S	12/2016	Holgate et al.
D777,070 S	1/2017	Nurnberger

(Continued)

OTHER PUBLICATIONS

U.S. Appl. No. 29/616,008, filed Sep. 1, 2017.

(Continued)

Primary Examiner — Melody N Brown

(74) *Attorney, Agent, or Firm* — Dorsey & Whitney LLP

(57) **CLAIM**

The ornamental design for an automobile and/or replica thereof, as shown and described.

DESCRIPTION

FIG. 1 is a top plan view of an automobile and/or replica thereof showing our new design;
FIG. 2 is a front elevation view thereof.
FIG. 3 is a rear elevation view thereof.
FIG. 4 is a left side elevation view thereof.
FIG. 5 is a left, front perspective view thereof;
FIG. 6 is a right side elevation view thereof; and,
FIG. 7 is a left, rear perspective view thereof.

The portions of the automobile shown in broken lines are for environmental and illustrative purpose and form no part of the claimed design.

1 Claim, 6 Drawing Sheets

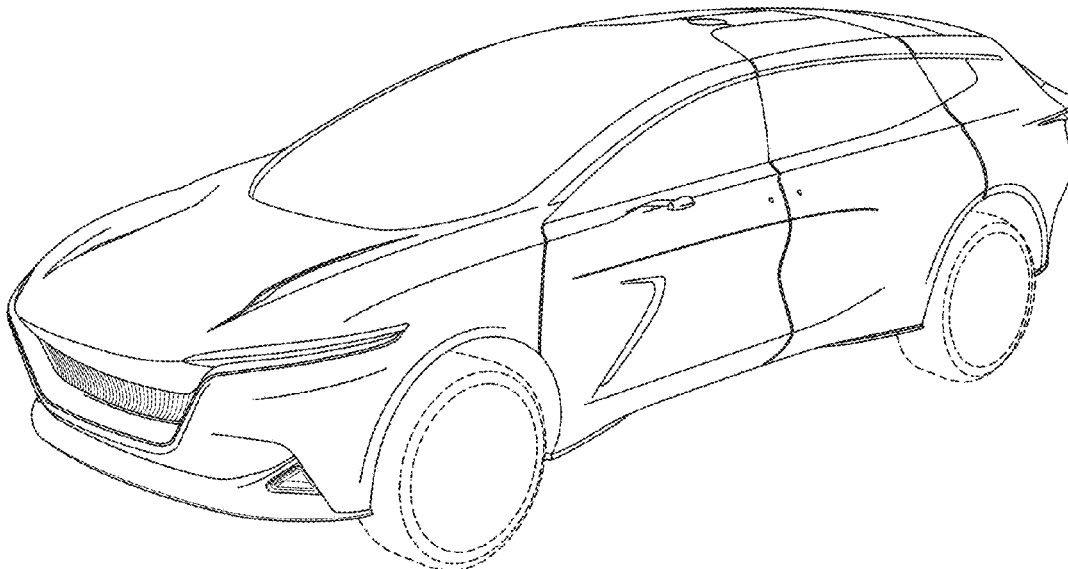

(56)

References Cited

U.S. PATENT DOCUMENTS

D778,790 S 2/2017 Nurnberger
 D780,632 S 3/2017 Nurnberger
 D780,633 S 3/2017 Nurnberger et al.
 D780,634 S 3/2017 Nurnberger et al.
 D780,636 S 3/2017 Kahn
 D785,525 S 5/2017 Nurnberger
 D786,155 S 5/2017 Holgate et al.
 D786,744 S 5/2017 Nurnberger et al.
 D796,404 S 9/2017 Nurnberger
 D796,999 S * 9/2017 Klimov D12/92
 D800,619 S 10/2017 Platt
 D801,558 S 10/2017 Nurnberger et al.
 D815,995 S 4/2018 Nurnberger et al.
 D817,814 S 5/2018 Nurnberger et al.
 D820,164 S 6/2018 Nurnberger et al.
 D825,387 S 8/2018 Nurnberger et al.
 D826,106 S 8/2018 Kahn
 D827,166 S 8/2018 Nurnberger et al.
 D827,410 S 9/2018 Earley
 D827,411 S 9/2018 Earley
 D827,507 S 9/2018 Nurnberger et al.
 D830,917 S 10/2018 Nurnberger et al.
 D833,187 S 11/2018 Earley
 D835,548 S 12/2018 Nurnberger et al.
 D838,017 S 1/2019 Nurnberger et al.
 D838,018 S 1/2019 Nurnberger et al.
 D840,873 S 2/2019 Nurnberger et al.
 D841,847 S 2/2019 Re et al.
 D842,799 S 3/2019 Nurnberger et al.
 D848,331 S 5/2019 Nurnberger et al.

D849,616 S 5/2019 Nurnberger et al.
 D855,528 S 8/2019 Re
 D856,193 S 8/2019 Nurnberger et al.
 D885,981 S * 6/2020 Lian D12/91

OTHER PUBLICATIONS

U.S. Appl. No. 29/631,883, filed Jan. 3, 2018.
 U.S. Appl. No. 29/631,887, filed Jan. 3, 2018.
 U.S. Appl. No. 29/582,592, filed Oct. 28, 2016.
 U.S. Appl. No. 29/616,006, filed Sep. 1, 2017.
 U.S. Appl. No. 29/616,010, filed Sep. 1, 2017.
 U.S. Appl. No. 29/626,411, filed Nov. 16, 2017.
 U.S. Appl. No. 29/626,801, filed Nov. 20, 2017.
 U.S. Appl. No. 29/647,968, filed May 17, 2018.
 U.S. Appl. No. 29/658,851, filed Aug. 3, 2018.
 U.S. Appl. No. 29/674,083, filed Dec. 19, 2018.
 U.S. Appl. No. 29/682,466, filed Mar. 5, 2019.
 U.S. Appl. No. 29/689,693, filed May 1, 2019.
 U.S. Appl. No. 29/689,689, filed May 1, 2019.
 U.S. Appl. No. 29/689,379, filed Apr. 29, 2019.
 U.S. Appl. No. 29/698,779, filed Jul. 19, 2019.
 U.S. Appl. No. 29/698,789, filed Jul. 19, 2019.
 U.S. Appl. No. 29/699,556, filed Jul. 26, 2019.
 Aston Martin 2013, "Aston Martin Centenary Celebration Programme," 2013; 204 pages.
 1976 and 1987 Aston Martin Lagonda, [online], [site visited Jul. 24, 2014], Available from Internet, <URL: <http://www.astonmartin.com/heritage/past-models/lagonda>>, 2 pages.

* cited by examiner

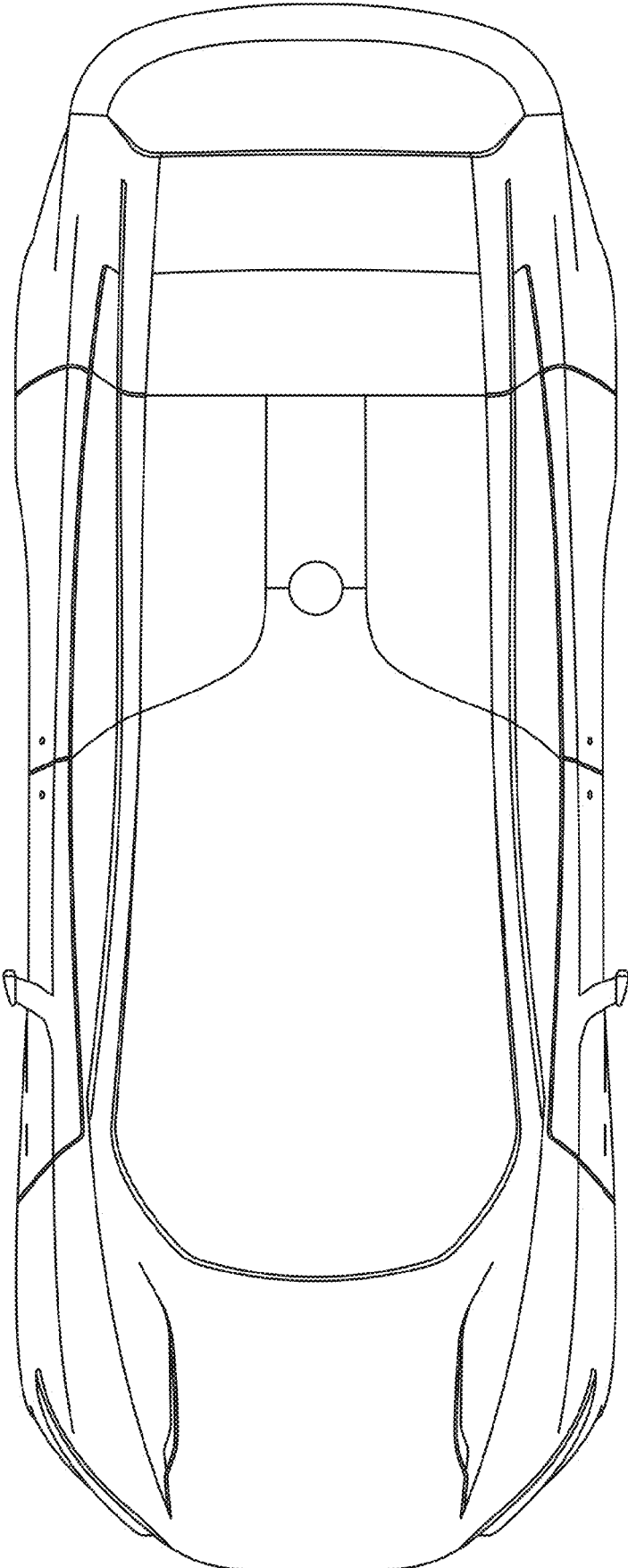

FIG. 1

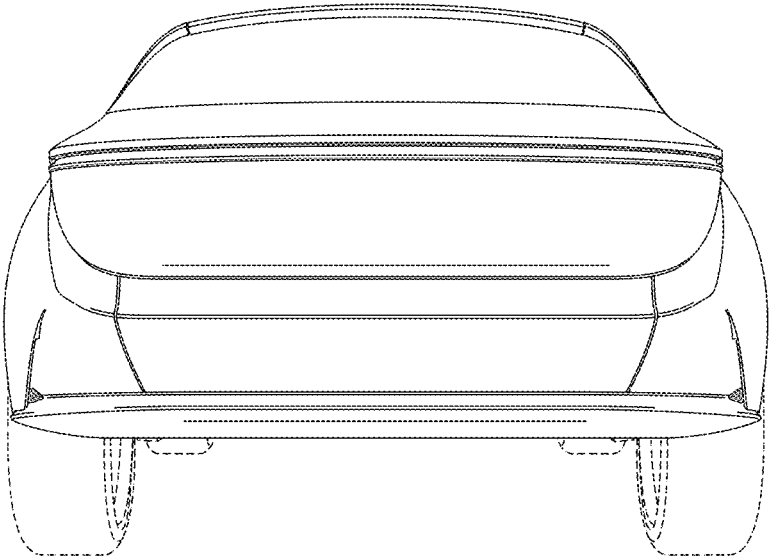

FIG. 2

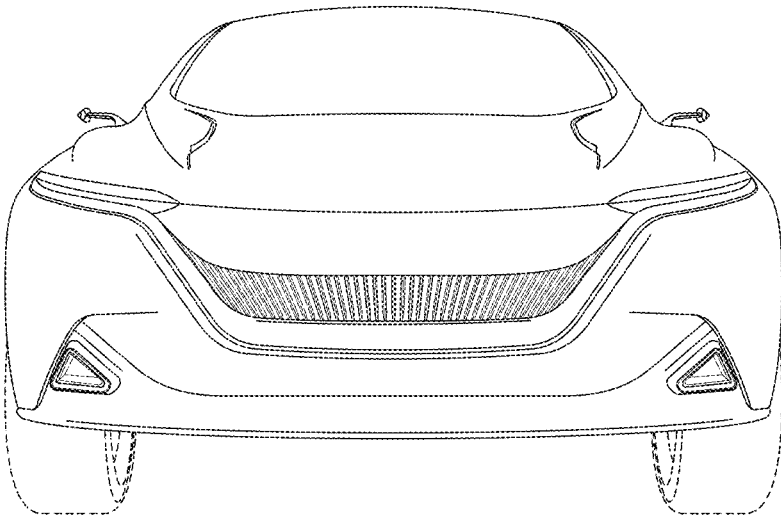

FIG. 3

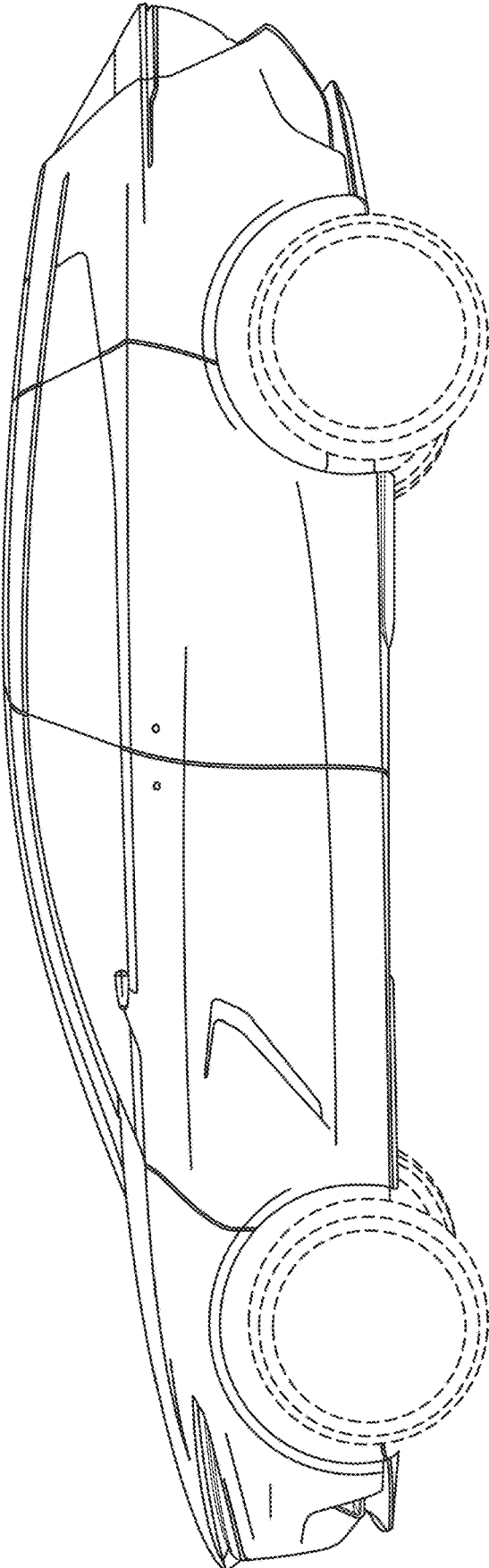

FIG. 4

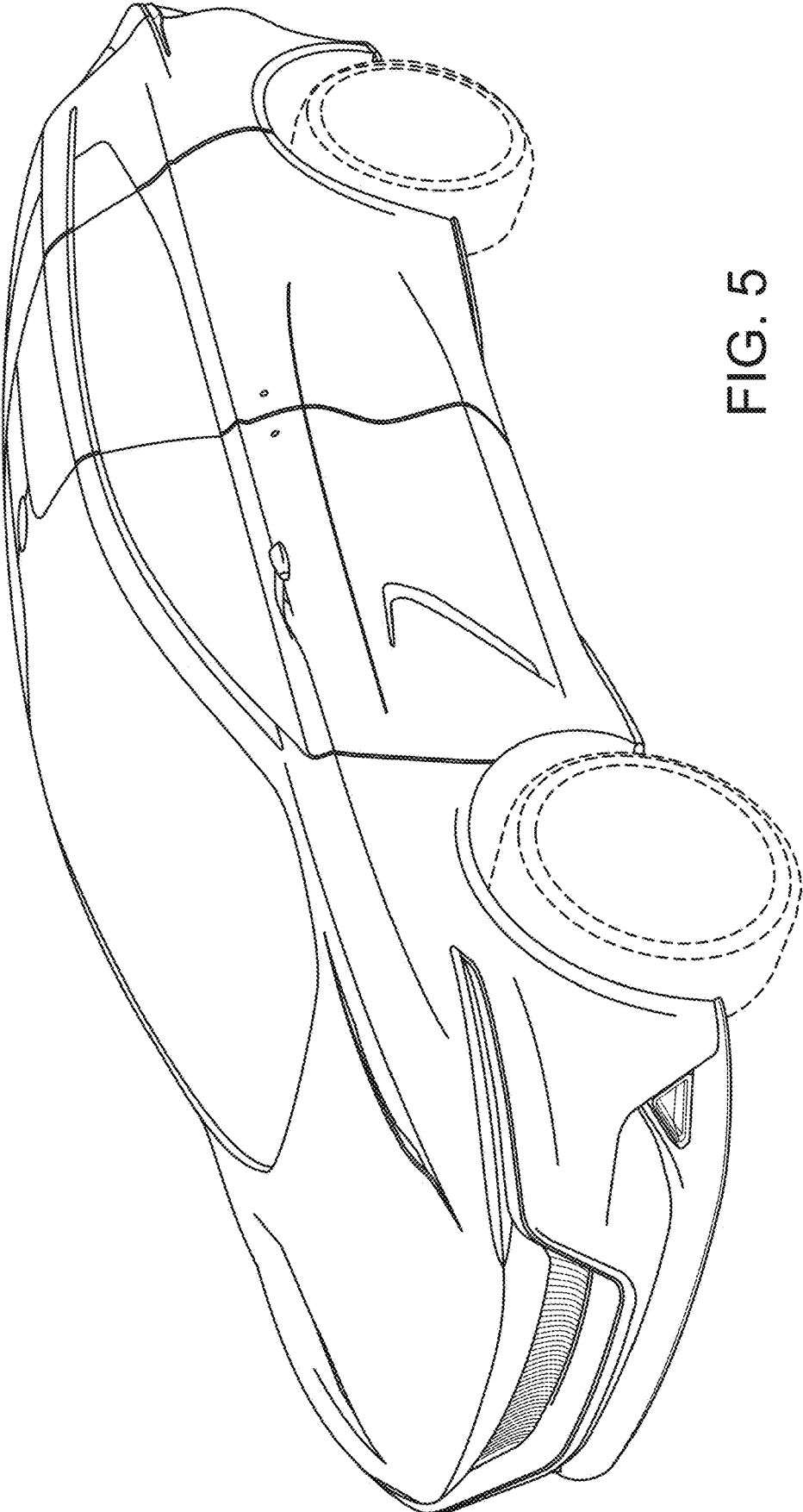

FIG. 5

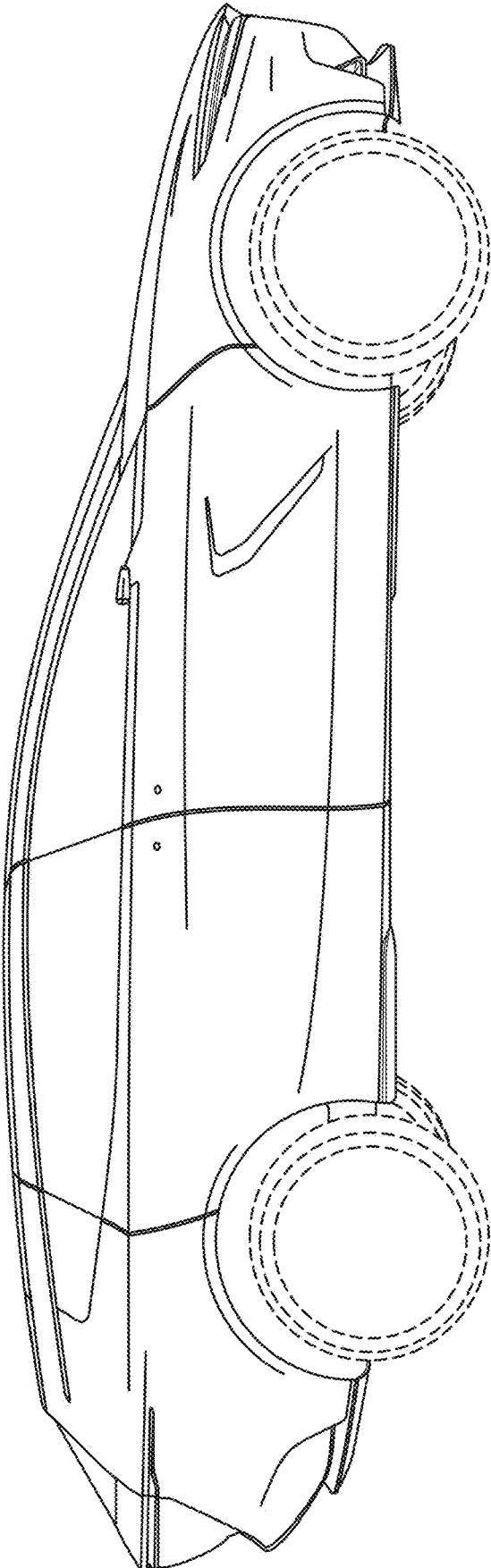

FIG. 6

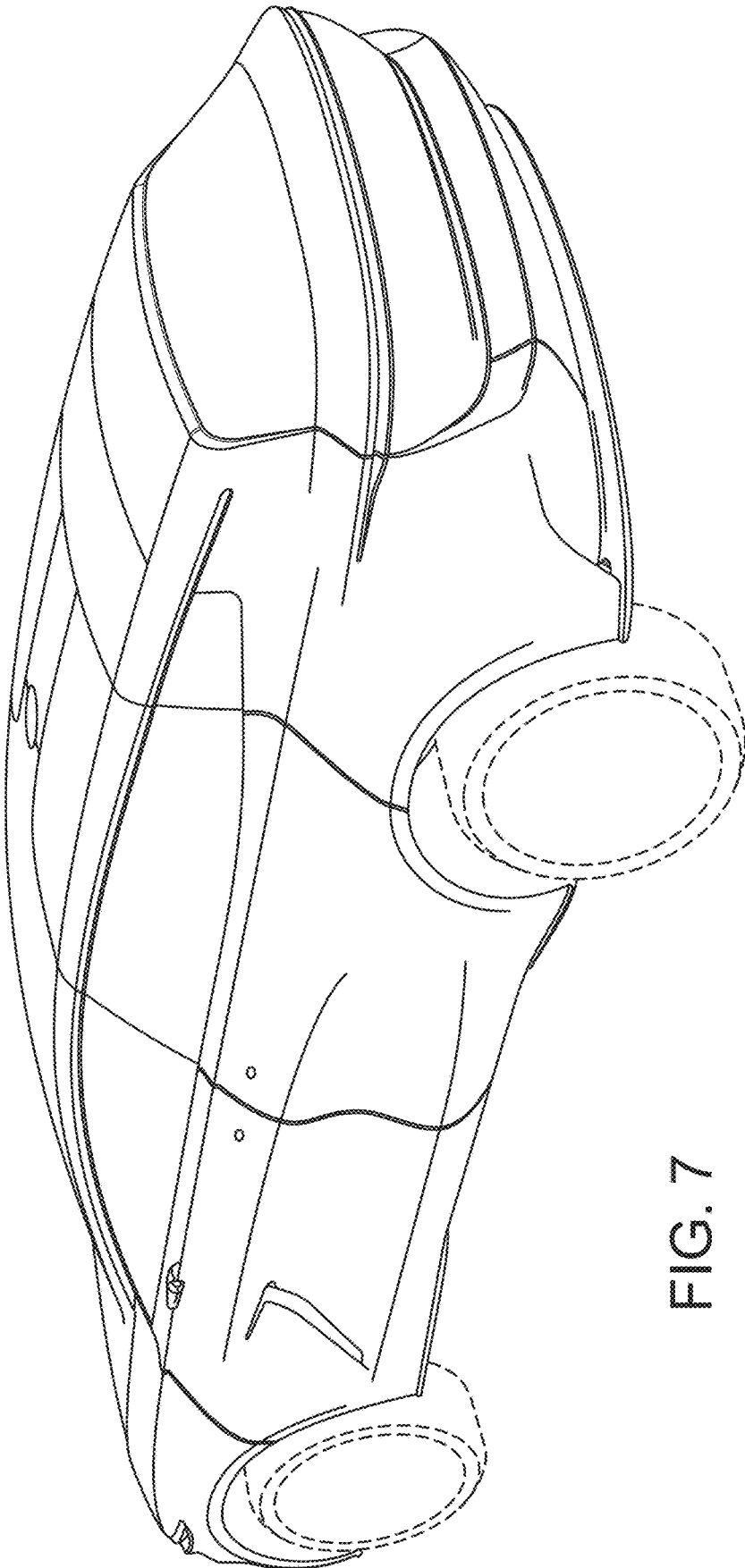

FIG. 7