



(51) International Patent Classification⁶ :
A61B 17/56

A1

(11) International Publication Number: WO 96/07361

(43) International Publication Date: 14 March 1996 (14.03.96)

(21) International Application Number: PCT/US95/11120

(22) International Filing Date: 1 September 1995 (01.09.95)

(30) Priority Data:

08/300,379 2 September 1994 (02.09.94) US
08/479,363 7 June 1995 (07.06.95) US

(71) Applicant: HUDSON SURGICAL DESIGN, INC. [US/US];
402 Route 173, Stewartville, NJ 08886 (US).

(72) Inventors: GOLDSTEIN, David, B.; 71 46th Street, Weehawken, NJ 07087 (US). HAINES, Timothy, G.; Yoz Route 173, Stewartville, NJ 08886 (US).

(74) Agent: FRISCIA, Michael, R.; Friscia & Nussbaum, 405 Murray Hill Parkway, East Rutherford, NJ 07073 (US).

(81) Designated States: AU, CA, JP, KR, European patent (AT, BE, CH, DE, DK, ES, FR, GB, GR, IE, IT, LU, MC, NL, PT, SE).

Published

With international search report.

(54) Title: FEMORAL AND TIBIAL RESECTION METHOD AND APPARATUS

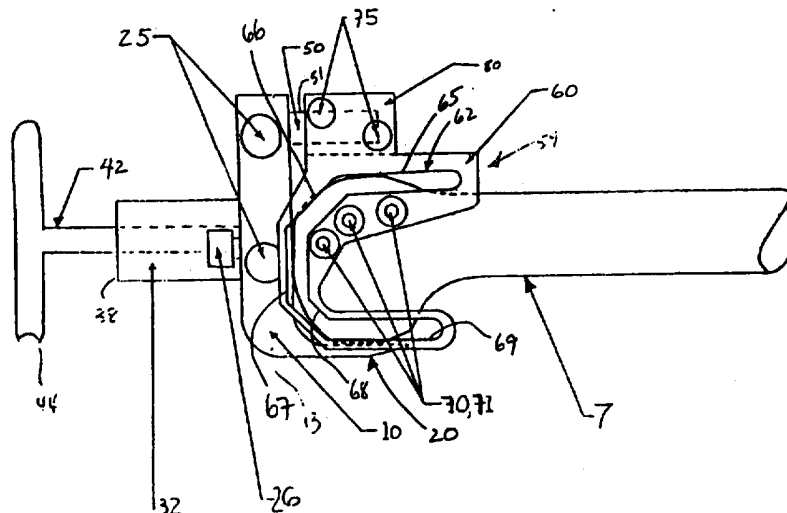

(57) Abstract

A femur and tibia resecting apparatus is provided for use in the preparation of a human distal femur and proximal tibia for the implantation of a prosthesis. The femur resecting apparatus includes a positioning apparatus (10) and a pattern device (60). The positioning apparatus (10) includes a positioning block (15) for attachment to a femur, an alignment block (32) having an intramedullary rod (42) extending into the femur, and a rotational adjustment device (50) for attachment of the pattern device (60) to the positioning apparatus (10). The pattern device (60) includes an individual or pair of mediolaterally located plates having a cutting path (65) described therethrough for guiding a cutting tool (90). The tibia resecting apparatus includes an ankle clamp (150), an alignment rod (160), a fixation head (180), cutting guide clamps (120) having cutting guide slots (122) therein, and a milling bit (155). The method includes using the femur resecting apparatus and the tibia resecting apparatus to prepare the femur and tibia for the prosthesis.

FOR THE PURPOSES OF INFORMATION ONLY

Codes used to identify States party to the PCT on the front pages of pamphlets publishing international applications under the PCT.

AT	Austria	GB	United Kingdom	MR	Mauritania
AU	Australia	GE	Georgia	MW	Malawi
BB	Barbados	GN	Guinea	NE	Niger
BE	Belgium	GR	Greece	NL	Netherlands
BF	Burkina Faso	HU	Hungary	NO	Norway
BG	Bulgaria	IE	Ireland	NZ	New Zealand
BJ	Benin	IT	Italy	PL	Poland
BR	Brazil	JP	Japan	PT	Portugal
BY	Belarus	KE	Kenya	RO	Romania
CA	Canada	KG	Kyrgystan	RU	Russian Federation
CF	Central African Republic	KP	Democratic People's Republic of Korea	SD	Sudan
CG	Congo	KR	Republic of Korea	SE	Sweden
CH	Switzerland	KZ	Kazakhstan	SI	Slovenia
CI	Côte d'Ivoire	LI	Liechtenstein	SK	Slovakia
CM	Cameroon	LU	Luxembourg	SN	Senegal
CN	China	LV	Latvia	TD	Chad
CS	Czechoslovakia	LU	Luxembourg	TG	Togo
CZ	Czech Republic	LV	Latvia	TJ	Tajikistan
DE	Germany	MC	Monaco	TT	Trinidad and Tobago
DK	Denmark	MD	Republic of Moldova	UA	Ukraine
ES	Spain	MG	Madagascar	US	United States of America
FI	Finland	ML	Mali	UZ	Uzbekistan
FR	France	MN	Mongolia	VN	Viet Nam
GA	Gabon				

5
TITLE: FEMORAL AND TIBIAL RESECTION METHOD AND APPARATUS
SPECIFICATION

BACKGROUND OF THE INVENTION

FIELD OF THE INVENTION

.0 This invention generally relates to a method and apparatus to
resect the distal human femur to allow it to properly accept a
distal femoral prosthesis. This invention also relates to a
method and apparatus for resecting a proximal human tibia to allow
it to properly accept a proximal tibial prosthesis in the context
.5 of a total knee replacement operation.

RELATED ART

Different methods and apparatus have been developed to enable
a surgeon to resect the distal human femur to allow attachment of
a distal femoral prosthesis (knee implant) to the human femur.
.0 Keeping in mind the ultimate goal of the procedure is to restore
the knee joint to normal function, it is critical that the
location and orientation of the knee implant approximates that of
the natural knee.

5 It is common to use the central axis of the femur, the
posterior and distal femoral condyles, and/or the anterior distal
femoral cortex as guides to determine the location and orientation
of distal femoral resections. The location and orientation of
these resections are critical in that they dictate the final
0 location and orientation of the distal femoral implant. It is
commonly thought that the location and orientation of the distal
femoral implant are critical factors in the success or failure of
the artificial knee joint. Past efforts have not been successful
in consistently properly locating and orienting distal femoral
resections.

5 In the past, efforts have also been made to develop methods
and apparatus to resect the proximal human tibia in the context of
knee replacement surgery. Many of these previous efforts, as
shown in the previous relevant patents, align the tibia resection
off of the intramedullary canal of the tibia, while others base
0 alignment off of exterior alignment rods. These previous efforts
also include alignment adjustment mechanisms, though these

mechanisms tend to be complicated and generally inaccurate. None of the methods or apparatus that have been developed can consistently and accurately locate and properly align the tibia resection, while minimizing the cutting skill necessary to properly and safely resect the tibia, as well as smoothly cutting the tibia. Nor do any of the previous efforts disclose a simple but effective method and apparatus for efficiently resecting the proximal tibia.

Such previous efforts at femoral and tibial resections are set forth in the following patents, none of which teach or suggest all of the benefits and advantages of the present invention. These previous patents include:

Stillwell, U.S. Patent No. 4,457,307, which discloses a movable saw and saw carriage which may be mounted to a patient's femur and positioned to cut the femur bone. An elongated rail is secured substantially parallel to the femur. A saw carriage and a carriage housing are attached to the rail. The saw has a blade extending substantially parallel to the direction of linear movement of the saw carriage. The saw carriage is slidably guided along paths substantially parallel to the elongated rails for making cuts in the femur bone. The saw may be positioned in a plurality of second positions where the saw carriage is slidably guided in paths substantially perpendicular to the elongated rail for making traverse distal femur cuts and for scoring the tibia cortex. Additionally, the saw may be positioned in a plurality of third positions where the saw carriage is slidably guided to form an acute angle with elongated rail for making anterior and posterior femur chamfer cuts.

Androphy, U.S. Patent No. 4,487,203, discloses a knee resection system comprising a guide member, femur and tibia guide rods, a tibia adaptor, a tibia bar, and a femur bar. After the distal femoral condyles are resected, the guide member is attached to the tibia guide rod extending into the tibia. The tibia guide rod has a second guide at a right angle for receiving the guide member. When properly aligned, the guide member is fixed to the anterior side of the proximal tibia with pins. The tibia is then resected with an oscillating saw inserted through slots in the

guide member.

Rohr, U.S. Patent No. 4,566,448, discloses a ligament tensor device having a first member to engage the tibia and a second member to engage the intercondylar notch of a femur and a means for moving the second means with respect to the first means for applying a selected tension to the ligaments of the joint. Additionally, the invention includes cutting guide slots for guiding the cutting of the femoral condyles.

Keller, U.S. Patent No. 4,586,496, discloses a surgical chisel having a flexurally rigid chisel shank and a thin, elongated chisel blade fixed at its front end. A chisel guide is provided having slides for displaceably guiding the blade and shank in a longitudinal direction.

Kenna, U.S. Patent Nos. 4,653,488 and 4,787,383, disclose a tibial cutting jig for cutting a tibia after the femur has been resected. The tibia is aligned off of the resected femur through longitudinal traction and manipulation to bring the ankle under the femur to produce a tibial angle of 2.5 degrees resulting in an overall valgus alignment. The alignment is verified by sight. The knee joint is then immobilized, the transverse tibial cutting jig is pinned to the tibia, the knee is moved to flexion, and the tibia is cut by resting the saw blade on the top surface of the cutting jig.

Russell, et al., U.S. Patent No. 4,722,330, discloses a distal femoral surface guide for mounting on an intramedullary alignment guide for use in shaping the distal femoral surface. A conventional shaping means such as an oscillating saw or hand saw is introduced into slots in the surface guide to resect the femur. The device also includes stabilizing members that extend along the sides of the femur to stabilize the device.

Fargie, et al., U.S. Patent No. 4,736,737 discloses a tibial cutting jig having a base that interconnects with an intramedullary alignment rod installed along the axis of the tibia. The base includes outriggers carrying measurement keys for spacing the base a preselected distance above the tibia. A saw guide having slots is attached to the base and is positioned to allow for the cutting of the tibia, by means of an oscillating

saw, at a selected position.

Zarnowski et al., U.S. Patent No. 4,892,093, discloses a cutting guide for a saw blade for resecting a femur. The device is attached to a femur after the distal end has been removed and a transverse surface has been established. The cutting guide includes a base member having a planar base surface. A pair of laterally spaced-apart locating and securing posts are integral with the base member and project in a direction normal to the base surface to interconnect with the femur. Guide members in the form of cylindrical bars are positioned within side members attached to the base. A saw blade may be inserted between the guide surfaces to properly position the blade to cut the femur.

Vandewalls, U. S. Patent No. 4,896,633, discloses a drill for drilling a hole into a femur. The device includes a positioning mechanism to firmly engage the outer peripheral surface of the femoral head and the femoral neck. This immobilizes the drill bushing relative to the femur and orients the axis of the drill with the central axis of the femur.

Whiteside, et al., U.S. Patent No. 5,002,545, discloses a shaping device for shaping the tibial plateau comprising an alignment rod located anterior to the anterior cruciate ligament and along the anterior cortex of the intramedullary canal of the tibia. The shaping guide is interconnected with the rod and is adjustable with respect to the rod to control the amount of resection of the tibial plateau by raising or lowering the cutting guide surfaces. The device includes a pin which is inserted into a hole on the alignment guide for setting rotation alignment by aligning the pin with the intercondylar notch of the femur.

Schmidt, U.S. Patent No. 5,049,149, discloses a sawing gauge system for intertrochanteric accommodation osteotomies for removing a wedge-shaped section of bone with a predetermined wedge-angle so that an optimal pre-stress load F can act.

Lackey, U.S. Patent No. 5,053,037, discloses a femoral drill guide with interchangeable femoral collets, a femoral reamer and a femoral anterior/posterior cutting block with an adoptable anterior femoral ledge. A plurality of diagonal slots are provided for making diagonal cuts in the distal end of the femur.

Ferrante et al. U.S. Patent No. 5,098,436, discloses a modular guide for shaping a femur comprising a first bracket defining a generally U-shaped structure having an internal surface adapted to be seated on the distal aspect of a resected femur bone and an elongated central opening appointed to expose a selected area of the resected femur, including a curved track for guiding a first shaping tool along a predetermined path for controlled shaping of a curved patellar groove and a portion of the selected area exposed through the opening. A second bracket defines a linear slotted bore extending generally parallel to the long axis of the femur for guiding a second shaping tool to form a relatively deep recess accommodating an intercondylar-stabilizing housing of a knee implant.

Brown, U.S. Patent No. 5,234,432, discloses a method of cutting the proximal end of a femur prior to cementing in a prosthesis for reconstructive hip surgery.

Poggie, et al., U.S. Patent No. 5,250,050 discloses an apparatus for use in preparing the bone surfaces for a total knee prosthesis, comprising cutting guides, templates, alignment guides, a distractor and clamping instruments. The instrument for alignment of the cutting surface for resecting the tibia includes an ankle clamp, an adjustable alignment rod, and a cutting platform. After the cutting platform is properly aligned on the tibia, it is pinned thereto and the tibia may be resected using an oscillating saw. Also disclosed is a patella resection guide comprising a scissor-type clamp having distal gripping arms, each of which define a cutting surface, and gripping teeth.

Caspari, et al., U.S. Patent Nos. 5,263,498, 5,228,459, and 5,304,181 disclose a method and apparatus for orthoscopically preparing bone surfaces for a knee replacement. A tibial jig is attached to the tibia at just above the ankle at a lower end and to just below the tibial tubercle at an upper end. One portal is formed in the knee for insertion of an orthoscope for viewing the knee, and another portal is formed for introducing resecting instruments. A cutting platform is aligned and secured in position and a cutting module is attached. Initially, a plunge cut across the tibial eminence is produced. This procedure is

repeated until the surface of the tibial plateau is covered with trails having ridges therebetween. Thereafter, the device is passed back and forth over the tibial plateau to remove the ridges.

5 Morgan, U.S. Patent No. 5,269,786, discloses a PCL oriented placement tibial guide method for guiding the tibial tunnel placement both inside and outside the knee in endoscopic ACL reconstruction.

10 Mikhail, U.S. Patent No. 5,284,842, discloses a universal patellar clamp having an articular surface clamping member with a central aperture defining a centerline axis. An anterior clamping member is positioned along the centerline axis and is movable with respect to the articular clamping member to effect clamping of the patella for accepting a reamer for reaming a cavity in the patella
15 of sufficient size to receive a patellar implant.

Johnson et al., U.S. Patent No. 5,306,276, discloses a tibial resector guide including a tibial alignment jig having an ankle adjustment mechanism, a telescoping rod and a tibial resector guide which includes a head having a slot for receiving a bone
20 saw. The head includes angled side walls along the slot which permit the guide to have a narrow anterior aperture, yet allow the saw blade to completely pass through the tibia.

Peterson, U.S. Patent No. 5,342,368, discloses an intramedullary tibial resector guide which is affixed to the tibia
25 by means of an intramedullary rod. An elongated bar extends from the intramedullary rod and carries a sleeve that supports a saw guide having a slot for receiving an oscillating saw.

Whitlock, et al., U.S. Patent No. 5,147,365, discloses a patella osteotomy guide comprising a plier-like appliance with
30 curved jaws for grasping a patella. A row of teeth face inwardly from the jaws and a rotating calibrated stylus measures the position of the patella with respect to an integral saw capture slot in each of the jaws. The jaws are curved with concave inner sides generally corresponding to the shape of a patella. With the
35 guide attached to a patella, a sagittal saw can be passed through the saw capture slots to cut away a portion of the patella.

 Additionally, Whiteside, U.S. Patent No. 4,474,177 describes

instruments for creating the distal femoral surfaces where a guide is used to index a flat surface used to guide the distal femoral resection. Kaufman, et al. U.S. Patent No. 4,721,104 describes a method of preparing the intracondylar area of the distal femur. Jellicoe, U.S. Patent No. 5,047,032 utilizes a side cutting drill to form the distal femoral surface.

None of these previous efforts, however, disclose all of the benefits and advantages of the present invention, nor do these previous patents teach or suggest all the elements of the present invention.

OBJECTS AND SUMMARY OF THE INVENTION

It is a primary object of the present invention to provide an apparatus for properly resecting the distal human femur.

It is also an object of this invention to provide an apparatus for properly orienting a resection of the distal human femur.

It is an additional object of the resection apparatus of the present invention to properly locate the resection apparatus with respect to the distal femur.

It is even another object of the resection apparatus of the present invention to provide a guide device for establishing the location and orientation of the resection apparatus with respect to the distal human femur.

It is still a further object of the resection apparatus of the present invention to lessen the chances of fatty embolisms.

It is even further object of this invention to provide a resection apparatus capable of forming some or all of the resected surfaces of the distal human femur.

It is another object of the resection apparatus of the present invention to provide an apparatus which is simple in design and precise and accurate in operation.

It is also an intention of the resection apparatus of the present invention to provide a guide device for determining the location of the long axis of the femur while lessening the chances of fatty embolism.

It is also an object of the resection apparatus of the present invention to provide a device to physically remove

material from the distal femur in a pattern dictated by the pattern device.

It is even another object of the resection apparatus of the present invention to provide a circular cutting blade for removing
5 bone from the distal human femur to resection the distal human femur.

It is also an object of the present invention to provide a method for easily and accurately resecting a distal human femur.

It is also an object of the present invention to provide a
10 method and apparatus for properly resecting the proximal human tibia in connection with knee replacement surgery.

It is also an object of the present invention to provide a method and apparatus for resecting the proximal human tibia which minimizes the skill necessary to complete the procedure.

It is another object of the present invention to provide a
15 method and apparatus for resecting the proximal human tibia which properly orients the resection of the proximal tibia.

It is even another object of the present invention to provide
20 a method and apparatus for resecting the proximal human tibia which is easy to use.

It is yet another object of the present invention to provide a method and apparatus for resecting the proximal human tibia which orients the resection in accordance with what is desired in the art.

It is still yet another object of the present invention to
25 provide a method and apparatus for resecting the proximal human tibia which minimizes the amount of bone cut.

It is a further object of the present invention to provide a method and apparatus for resecting the proximal human tibia which
30 allows one to visually inspect the location of the cut prior to making the cut.

It is even a further object of the present invention to provide a method and apparatus for resecting the proximal human tibia which is simple in design and precise and accurate in
35 operation.

It is yet a further object of the present invention to provide a method and apparatus for resecting the proximal human

tibia which physically removes material from the proximal tibia along a surface dictated by a guide device.

It is still a further object of the present invention to provide a method and apparatus for resecting the proximal human tibia which employs a milling bit for removing material from the proximal tibia.

It is also object of the present invention to provide a method and apparatus for resecting the proximal human tibia which includes a component which is operated, and looks and functions, like pliers or clamps.

It is even another object of the present invention to provide an alternate embodiment of the method and apparatus for resecting the proximal human tibia which includes a component that resembles a U-shaped device for placing about the tibia.

It is even a further object of the present invention to provide an alternate embodiment of the method and apparatus for resecting the proximal human tibia which includes a component that resembles an adjustable, square, U-shaped device for placing about the tibia.

These objects and others are met by the resection method and apparatus of the present invention. This apparatus comprises a number of components including a guide device, a pattern device and a cutting device.

The pattern device is oriented and located by the use of the positioning apparatus which references the geometry of the distal femur with respect to the long axis of the femur. Once the positioning apparatus has been properly located, aligned, and initially fixed in place, the pattern device may be rigidly fixed to the distal femur. This ensures the pattern device is properly located and oriented prior to the use of the cutting device to remove material from the distal femur thus dictating the final location and orientation of the distal femoral prosthesis.

More specifically, the positioning apparatus is located and aligned utilizing the intramedullary canal of the femur, (thereby approximating the long axis of the femur). The distal surfaces of the femur, and the posterior surfaces will indicate the appropriate locations and orientations of the positioning

apparatus. Fixation screws may be used to fix the guide device to the distal femur. The pattern device may then be attached to the positioning apparatus so that the location and orientation of the pattern device matches that of the positioning apparatus. Means
5 may be present in the positioning apparatus and/or pattern device for allowing the following additional adjustments in the location and orientation of the pattern device: 1. internal and external rotational adjustment; 2. varus and valgus angular adjustment; 3. anterior and posterior location adjustments; and 4. proximal and
10 distal location adjustment.

Cannulated screws and fixation nails may then be used to firmly fix the pattern device to the distal femur. Thus, the location and orientation of the pattern device is established.

The pattern device possesses slot like features, or a cutting
15 path, having geometry that closely matches the interior profile of the distal femoral prosthesis. The cutting path guides the cutting device through the aforementioned slot-like features to precisely and accurately remove material from the distal femur. Thus the distal femur is thereby properly prepared to accept a properly
20 aligned and located distal prosthesis.

The apparatus of the present invention for resecting the tibia comprises a number of components including an ankle clamp, an alignment rod, a fixation head, cutting guide clamps having an integral attachment mechanism, and a milling bit.

The method of present invention for resecting the tibia
25 includes the steps of attaching the ankle clamp about the ankle, interconnecting the distal end of the alignment rod with the ankle clamp, interconnecting the fixation head with the proximal end of the alignment rod, partially attaching the fixation head to the proximal tibia, aligning the alignment rod, completely attaching
30 the fixation head to the proximal tibia, interconnecting the cutting guide clamps with the alignment rod, positioning the cutting guide clamps about the proximal tibia, securing the cutting guide clamps to the tibia at a proper location, removing
35 the fixation head, and cutting the proximal tibia with the milling bit.

BRIEF DESCRIPTION OF THE DRAWINGS

Other important objects and features of the invention will be apparent from the following Detailed Description of the Invention taken in connection with the accompanying drawings in which:

5 Fig. 1. is an exploded view of the resection apparatus of the present invention showing the positioning apparatus body, the angular adjustment component and the rotational alignment component.

10 Fig. 2 is a side plan view of the guide device of the resection apparatus of Fig. 1 attached to a distal human femur.

Fig. 3 is an exploded view of the pattern device of the resection apparatus of the present invention.

Fig. 4 is a side plan view of the resection apparatus shown in Fig. 2 with the pattern device fixed to the distal human femur.

15 Fig. 5 is an exploded front view of the cutting device of the resection apparatus of the present invention.

Fig. 6 is a top plan view of the pattern device and the cutting device of the resection apparatus of the present invention affixed to the distal human femur.

20 Fig. 7 is a side plan view of an intramedullary rod having a helical groove for use with the resection apparatus shown in Fig. 1.

25 FIG. 8 is a partially exploded side plan view of an embodiment of the tibial resection apparatus of the present invention shown attached to the tibia, wherein the cutting guide clamps are of a fixed size and directly interconnect with the alignment rod.

30 FIG. 9 is a top plan view of the tibial resection apparatus shown in FIG. 8 prior to insertion of the milling bit into the apparatus.

FIG. 10 is a partially exploded side plan view of another embodiment of the tibial resection apparatus shown in FIG. 8, wherein the cutting guide clamps interconnect with the alignment rod by means of a cutting guide clamp linkage.

35 FIG. 11 is a side plan view of an embodiment of the cutting guide clamps shown in FIG. 8, wherein the cutting guide clamps are adjustable.

FIG. 12 is a top plan view of the cutting guide clamps shown in FIG. 11.

FIG. 13 is a perspective view of an embodiment of the tibial resection apparatus shown in FIG. 8, showing the proximal tibial referencing stylus attached to the cutting guide clamps.

FIG. 14 is a cross-sectional view of the profile of the ends of the clamp members taken along line A - A in FIG. 12.

FIG. 15 is a cross-sectional view of the profile of the ends of the cutting guides taken along line B - B in FIG. 12, the ends of the clamps mating with the ends of the cutting guides for positioning the cutting guides with respect to the clamps.

FIG. 16 is a perspective view of an alternate embodiment of a U-shaped cutting guide for use in the present invention.

FIG. 17 is a top plan view of another alternate embodiment of a square U-shaped cutting guide for use in the present invention.

FIG. 18 is a perspective view of another alternate embodiment of a partial cutting guide for use in the present invention when the patellar tendon, patella, or quad tendon interferes with placement of the cutting guide about the tibia.

DETAILED DESCRIPTION OF THE INVENTION

As shown generally in Figs. 1-6, the resecting apparatus of the present invention comprises a number of components, namely positioning apparatus generally indicated at 10 comprising positioning body generally indicated at 12, angular adjustment block generally indicated at 32, rotational alignment device generally indicated at 50, pattern device generally indicated at 59 and cutting means generally indicated at 90.

As shown in detail in Fig. 1, the positioning apparatus, generally indicated at 10, includes a positioning body generally indicated at 12 having sides 13, top surface 14, front surface 15, back surface 19 and cross member 18. Extending from a lower end of the positioning body 12 is positioning tongue 20 having an upper surface 22. Extending into the positioning body 12 from the top surface 14 to the cross member 18 and through the front and back surfaces 15 and 19, is a gap generally defined by slots 16 and partial slot walls 17. Sides 13 include apertures 24 for receiving locking screws 25. Also extending through the body 12 from the

back surface 19 to the front surface 15 are apertures 27 for receiving fixation screws 26.

The positioning apparatus 10 receives and holds angular adjustment block generally indicated at 32. Angular adjustment block 32 includes a front surface 34 having wings 36 sized to be received by the slots 16 in the positioning body 12 to hold the angular adjustment block 32. The angular adjustment block 32 is locked into place in the positioning body 12 by means of locking screws 25 which extend through apertures 24 in the positioning body 12 and contact the wings 36 of the angular adjustment block 32 to secure the angular adjustment 32 to the positioning body 12. The angular adjustment block 32 establishes the angular alignment and anterior/posterior location of the positioning apparatus 10.

The angular adjustment block 32 also includes back surface 38 and an aperture 40 extending from the back surface 38 through the angular adjustment block 32 to the front surface 34. The aperture 40 receives an intramedullary rod 42 therethrough. The intramedullary rod 42 comprises a shaft 43 and a handle 44. The shaft 43 extends through the angular adjustment block 32 and into the intramedullary canal which extends along the axis of the femur to aid in establishing the orientation of the resection apparatus of the present invention as hereinafter described.

The rotational alignment device, generally indicated at 50, includes a shaft 51 having a groove 52 therealong and a block 53 having a back surface 54 and wings 56. The rotational alignment device 50 is interconnected with the positioning body 12 by means of the wings 56 received in slots 16 of the positioning body 12. The rotational alignment device 50 may be secured to the positioning body 12 by means of locking screws 25 which extend through apertures 24 in the positioning body 12 to contact the wings 56. The locking screws 25 may be made of various configurations depending upon their specific function. Importantly, the locking screws 25 are used to rigidly affix one component or device to another to ensure that the relative locations and orientations are maintained despite the rigors of surgery.

As shown in Fig. 2, wherein the positioning body 12 is fitted

with the angular adjustment block 32 and the rotational alignment device 50, the entire positioning apparatus 10 is connected to a human femur 7 by means of the shaft 43 of the intramedullary rod 42. The shaft 43 extends through the angular adjustment block 32, and thereby through the positioning body 12 into the intramedullary canal which extends along the axis of the femur 7. The intramedullary rod 42, shown in Fig. 7, has a groove 41 transversing a helical path 45 along the axis of the shaft 43. The groove 41 relieves intramedullary pressure that leads to fatty embolisms. The basic concept of the intramedullary rod 42 with the groove 41, is that as it is inserted into the femur, which contains liquid fatty tissue, the liquid fatty tissue is drawn up the groove 41 of the intramedullary rod 42 to draw the fatty liquid tissue out of the femur. Preferably, the intramedullary rod would have a hexagonal head (not shown), to permit it to be driven by a powered device such as an electrical hand held tool. Importantly, the groove 41 does not have a cutting edge, which would risk perforation of the femoral cortex. Accordingly, the device does not cut solid material, but does remove liquid material from the intramedullary canal. Therefore, the risk of fatty embolism is reduced.

After positioning body 12 is properly located against the femur 7 by means of the intramedullary rod 42 and the angular adjustment block 32, fixation screws 26 may be advanced through the apertures 27 in the positioning body 12 until they make contact with the distal femoral condyles of the femur 7, and are then driven into the distal femoral condyles of the femur 7 to initially affix the positioning apparatus to the distal femur 7. It should be noted that the fixation screws 26 may also be advanced and adjusted to make up for deficiencies in the distal femoral condyles. Accordingly, the positioning body 12 is positioned such that the front surface 15 is put into contact with the distal femoral condyles by direct contact, and the tongue 20 is positioned under the femur 7 and in contact therewithin.

As can be seen in Fig. 2, the shaft 51 of the rotational alignment device 50 extends above the femur 7 and allows for rotation of the pattern device 59, hereinafter described, about

the distal femur 7. Additionally, the rotational alignment device 50 allows for the anterior/posterior positioning of the pattern device 59 with respect to the femur 7. Importantly, the configurations of the positioning body 12, the angular adjustment block 32 and the rotational alignment device 50 are not limited to the structure set forth herein, but may be of different shapes and may interconnect in different ways. These components may be formed as a unitary or partially unitary device.

As shown in Fig. 3, the pattern device 59 includes pattern plates 60 having tops 61, and cutting paths, generally indicated at 62, extending therethrough. The cutting paths 62 outline the desired resection shape of the distal femur 7. Generally, the cutting paths 62 could include a first vertical path 64, extending to a first diagonal path 65, extending to a second diagonal path 66, extending to a second vertical path 67, extending to a third diagonal path 68 and then extending to a horizontal path 69. Alternatively, the cutting paths 62 could describe any desired resection shape for the femur 7. The pattern plates 60 also include locking screws 75 for interconnecting the pattern plates 60 with crossbar 80.

The pattern device 59 of the present invention preferably includes two pattern plates 60 held in a spaced apart relationship by crossbar 80. The crossbar 80 separates the pattern plates 60 sufficiently to permit the pattern plates 60 to extend along the sides of distal femur 7. The crossbar 80 includes a front surface 82, back surface 84, a top surface 83, a central aperture 86 extending from the front surface 82 to the back surface 84, a lock aperture 88 extending through the top surface 83, and a lock screw 89. The central aperture 86 of the crossbar 80 receives the shaft 51 of the rotational alignment device 50. Accordingly, the pattern device 59 is interconnected with the positioning apparatus 10 so that the pattern device 59 is properly oriented with respect to the femur 7. Upon proper positioning of the crossbar 80 with respect to the shaft 51 of the rotational alignment device 50, lock screw 89 is extended through lock aperture 88 to contact the shaft 51 to lock the crossbar 80 and, accordingly, the pattern device 59, onto the shaft 51 of the rotational alignment device

50, and accordingly, to positioning apparatus 10. This completed assembly, attached to the femur 7, is shown in Fig. 4.

As additionally shown in Figs. 3 and 4, the pattern plates 60 include plate apertures 72 for receiving cannulated screws 70 which have apertures extending therethrough for receiving fixation nails 71 therethrough. Accordingly, after the pattern device 59 is interconnected with the positioning apparatus 10, and properly located and oriented with respect to femur 7, the cannulated screws 70 are extended through the plate aperture 72 to contact the sides of distal femur 7. Then, in order to fix the pattern plates 60 with respect to the femur 7, the fixation nails 71 are driven into the distal femur 7 to lock the pattern plate 60 into position on the distal femur 7. The cannulated screws 70 have sharp leading edges for allowing decisive purchase in the distal femur 7 before the introduction of the fixation nails 71 to complete fixation of the pattern device 59 to the distal femur 7.

The pattern plates 60 by virtue of the cutting paths 62, dictate the shape of the resection of the femur 7. The cutting paths 62 are essentially channels through the pattern plates 60. The cutting paths 62 receive the cutting device and guide and guide it as it resects the surface of the distal femur 7. The pattern plates 60 straddle the distal femur 7 mediolaterally and are suspended by the crossbar 80. Likewise, the crossbar 80 maintains the proper relationship between the pattern plates 60 before and during the resection of the distal femur 7. The location of the crossbar 80 and accordingly, the [pattern plates 60, may be adjusted with respect to the positioning apparatus 10 by adjusting the position of the block 53 of the rotational alignment device 50 within the slots 16 of the positioning body 12, and locking the same with locking screws 25.

The cutting paths 62 in the pattern plates 60 receive and guide the cutting device shown in Fig. 5 and generally indicated at 90. The cutting device 90 performs the actual cutting of the femur 7 to resect the femur 7. The cutting device may be of any known configuration. In a preferred embodiment the cutting device is a drill. The drill 90 is generally cylindrical in shape and may possess helical cutting teeth along its length to cut the femur 7.

The drill 90 includes a hexagonal end 95 to permit the use of an electric powered drive, typically an electric drill. Further, the drill 90 includes drill bushings 92 at the ends of the drill 90 to provide a non-metallic bearing between the cutting paths 62 in the pattern plates 60 to avoid galling and to ensure smooth articulation of the drill 90 along the cutting path 62. Positioned between the drill bushings 92 and the drill 90 are retention springs 94 which are essentially coil springs retained within the drill bushings 92 to allow the drill bushings 92 to be easily attached and removed from the drill 90. These retention springs 94 are commercially available in medical grade stainless steels. The drill bushings 92 retain the retention springs 94 which hold the drill bushings 92 in position 92 on the drill 90 while allowing the drill bushings 92 to rotate freely. The drill 90 may also include circumferential grooves 91 for allowing attachment and retention of the drill bushings 92 by means of the retention springs 94. Importantly, the configuration of the drill 90 can vary in accordance with what is known in the art as long, as long as the cutting device can follow the cutting paths 62 in the pattern plates 60 to resect the femur 7.

As shown in Fig. 6, after the pattern device 59 is attached to the distal femur 7, and positioned accordingly by means of the positioning apparatus 10, and secured to the distal femur 7 by means of cannulated screws 70 and fixation nails 71, positioning apparatus 10 may be removed from connection to the distal femur 7 leaving the pattern device 59 attached to the distal femur 7 to permit resecting of the distal femur. The drill 90 is then positioned within the cutting paths 62 between the pattern plates 60. Next the drill 90 is rotated by power means in connection with the hexagonal end 95, and is then moved along the cutting path 62 to resect the distal femur 7. It should also be noted that the cutting means could be operated by hand.

Instead of two pattern plates 60, a single pattern plate could be employed if it is sufficiently sturdy to support and guide the drill. The pattern plates 60 may also comprise plates having edges in the shape of the desired distal femoral resection pattern. Thus, the cutting device may be drawn along the edges of

the pattern plates to resect the distal femur. Further, any cutting device that can be employed to follow the cutting paths in the pattern plates is considered to be within the scope of this invention.

5 The resection apparatus of the present invention, through proper use as previously described, provides extremely accurate and reproducible bone cuts. While the anterior and distal areas of the femur will almost always be able to be prepared in this manner, interference from soft tissue such as fat and ligaments
10 may prohibit satisfactory preparation of the posterior femur. The preparation of any remaining femoral surfaces may be completed in any manner known in the art after using the instrumentation of the present invention.

 As shown in FIGS. 8-13, the tibial resection apparatus of the
15 present invention includes a number of components, namely, cutting guide clamps generally indicated at 110, cutting guides generally indicated at 120, ankle clamp generally indicated at 150, alignment rod generally indicated at 160, cutting guide clamp linkage generally indicated at 170, fixation block generally
20 indicated at 180, proximal tibial referencing stylus generally indicated at 190, and milling bit generally indicated at 155. It should be noted that the cutting guides 120 may be formed integrally with the cutting guide clamps 110 as shown in FIGS. 8 and 9, or a separate members as shown in FIGS. 11, 12 and 13.
25 Also, the cutting guides 120 may ride the alignment 160 as shown in FIGS. 8 and 9, or they may interconnect with the alignment rod 160 by means of cutting guide clamp linkage 170 as shown in FIGS. 11, 12 and 13.

 As shown in FIG. 8, the ankle clamp 150 is attached at or
30 just above the ankle and exterior to the skin. Any conventional ankle clamp may be used to firmly engage the ankle, or to engage the tibia above the ankle, to obtain a reference point for the other components of the present invention. The ankle clamp is interconnected with and locked into place on the alignment rod 160
35 in any way known in the art. Preferably, though not necessarily, the alignment rod 160 is vertically adjustable with respect to the ankle clamp 150. This vertical adjustment can be achieved at the

ankle clamp 150, at the interconnection of the ankle clamp 150 and the alignment rod 160, or within the alignment rod 160 itself. As shown in FIG. 8, the alignment rod includes a first lower end 162 having an aperture 163 extending vertically therein for telescopically receiving a second upper end 165 of the alignment rod 160. A set screw 164 is provided for fixing the upper end 165 with respect to the lower end 162.

The fixation block 180 is interconnected with an upper end of the alignment rod 160 by means of an aperture 182 in the fixation block 180 sized to receive the alignment rod 160 therethrough, or in any other manner known in the art. A set screw 184 may be provided to extend into the fixation block 180, through set screw aperture 186 in fixation block 180, to contact the alignment rod 160, to lock the fixation block 180 onto the alignment rod 160. The fixation block 180 additionally includes apertures extending vertically therethrough for receiving fixation pins 188 for affixing the fixation block 180 to the proximal tibia 108.

In operation, the ankle clamp 150 is attached about the ankle, or about the tibia just above the ankle, on the exterior of the skin. The fixation block 180 is already interconnected with the alignment rod 160. It is preliminarily positioned over the proximal tibia 108, and one of the fixation pins 188 is driven into the proximal tibia 108. Thereafter, the alignment rod 160 is adjusted to establish proper varus/valgus alignment and flexion/extension angulation as is conventionally known. Upon proper alignment of the alignment rod 160, the other fixation pin 188 is driven into the proximal tibia 108 to completely fix the fixation block 180 to the proximal tibia 108 to lock in the proper alignment of the alignment rod 160. Then, the fixation block 180 may be locked into position on the alignment rod 160.

After properly aligning and locking in the alignment of the alignment rod 160, the cutting guide clamps 110 and the cutting guides 120 may be employed. The cutting guide clamps 110 are interconnected with the alignment rod 160 by means of cutting guide linkage 170. Alternatively, the cutting guide clamps 110 could directly interconnect with the alignment rod 160 through apertures in the cutting guide clamps 110 as shown in FIGS. 8 and

9. As shown in FIG. 10, the cutting guide clamp linkage 170 comprises a body 171 having an alignment rod aperture 172 for receiving and riding the alignment rod 60 and a pivot locking set screw 174 which extends into the cutting guide clamp linkage 170 through set screw aperture 175 for contacting the alignment rod 160 and locking the cutting guide clamp linkage 170 with respect to the alignment rod 160. It should be pointed out that it may be desirable for the alignment rod 160 to have a flattened surface extending longitudinally along the alignment rod 160 for coaxing with set screw 174 for maintaining proper alignment between the cutting guide clamp linkage 170 and the alignment rod 160.

The cutting guide clamp linkage 170 also includes a pivot shaft 176 rigidly interconnected with the body 171 of the cutting guide clamp linkage 170 by member 177 to position the pivot shaft 176 a distance away from the body 171 such that the cutting guide clamps 110 can be interconnected with the pivot shaft 176 and can be properly utilized without interfering with the body 171 of the cutting guide clamp linkage 170.

After the alignment rod 160 is properly aligned and locked into position, the cutting guide clamp linkage 170 is moved into its approximate desired position at the proximal tibia 108. It should be noted that the cutting guide clamp linkage 170 of present invention is positioned on the alignment rod 160 at the beginning of the procedure, prior to aligning the alignment rod 160, and prior to interconnecting the fixation block 180 with the alignment rod 160. However, it is within the scope of the present invention to provide a cutting guide clamp linkage 170 which is attachable to the alignment rod 160 after the alignment rod 160 has been aligned and locked into position.

After the cutting guide clamp linkage 170 is preliminarily approximately located, it is locked into place on the alignment rod 160. Thereafter, the cutting guide clamps 110 may be interconnected with the pivot shaft 176 by means of corresponding pivot apertures 117 in the cutting guide clamps 110.

As shown in FIGS. 11 and 12, the cutting guide clamps 110 include opposing hand grips 112 for grasping and manipulating the cutting guide clamps 110. Cross bar members 114 extend from the

hand grips 112 to clamp members 118. The cross bar members 114 cross over each other at cross over point 115 whereat the cross bar members 114 have mating recessed portions 116 which function to maintain the hand grips 112 in the same plane as the clamp members 118. At the cross over point 115, the cross bar members 114 can pivot with respect to each other such that movement of the hand grips 112 towards each other moves the clamp members 118 together, and likewise, movement of the hand grip members 112 away from each other serves to move the clamp members 118 apart in the same manner as scissors or pliers. At the cross over point 115, the cross bar members 114 have corresponding pivot apertures 117 for receiving the pivot shaft 176 of the cutting guide clamp linkage 170. Thus, the cutting guide clamps 110 pivot about the pivot shaft 176 of the cutting guide clamp linkage 170. It should be noted that the cross bar members 114 could be interconnected with each other by a rivet or other means known in the art, or could be entirely independent pieces which coact as set forth above only upon being seated on pivot shaft 176.

The clamp members 118 of the cutting guide clamps 110 include cutting guide adjustment screw apertures 119 at the far ends thereof for receiving A-P adjustment screws 130 for adjustably interconnecting the cutting guides 120 with the clamp members 118, for adjustable movement in the direction shown by arrow C in FIG. 11. The clamp members 118 may be adjustably interconnected with the cutting guides 120 in any way known in the art. In one embodiment, the cutting guide adjustment screw apertures 118 are threaded and the cutting guides 120 have corresponding elongated apertures 128 extending over a portion of the length thereof for receiving the A-P adjustment screws at a desired location therealong. The A-P adjustment screws include a head 131, a retaining head 132, and a threaded shaft 134. When the cutting guides 120 are positioned correctly with respect to the clamp members 118, the A-P adjustment screws 130 are tightened down to lock the cutting guides 120 onto the clamp members 118 by actuating the head 131 to turn down the threaded shaft 34 with respect to the clamp member 118. Note the retaining head 132 of the A-P adjustment screws prevent the shaft 134 from being backed

off out of engagement with the clamp member 118.

As shown in FIGS. 14 and 15, respectively, the clamp members 118 are shaped with opposing interior edges having chamfers 138 and the opposite exterior edges of the cutting guides 120 have mating recesses 139, both of said profiles extending along the contacting surfaces of the clamp members 118, as seen along line A-A in FIG. 12, and the cutting guides 120, as seen along line B-B in FIG. 12, to maintain a proper planar alignment therebetween. It should of course be noted that any other method known in the art may be employed to maintain the clamp members 118 and the cutting guides 120 in alignment. Additionally, the cutting guides 120 may include A-P adjustment screw recesses 137 for receiving the head 131 of the A-P adjustment screw 130.

The cutting guides 120 further include tibia attachment means for attaching the cutting guides 120 to the tibia 108. Any known attachment means may be employed to attach the cutting guides 120 to the tibia 108. As shown in FIGS. 9 and 11, a preferred attachment means are pins 136 extending through pin apertures 127 in the cutting guides 120. The pins 136 may be captured in the pin apertures 127, or they may be entirely separate. Preferably, means exist on the cutting guides 120 for preliminarily attaching the cutting guides 120 to the tibia 108 prior to pinning the cutting guides 120 thereto, so that after proper positioning of the cutting guides 120, the hand grips 112 can be actuated by squeezing the hand grips 112 together to contact the cutting guides 120 against the tibia 108 so that the cutting guides 120 are preliminarily attached to the tibia 108. Such means may include a plurality of small pins captured by the cutting guide 120, or any other suitable means. After the preliminary attachment of the cutting guides 120 to the tibia 108, final attachment may be made by attachment pins 136 or by any other means known in the art.

The cutting guides 120, importantly, include cutting slots 122 which each comprise lower cutting slot guide surface 123 and upper cutting slot retaining surface 125, as well as cutting slot entrance and exit 124 at one end thereof and cutting slot end wall 126 at the other end thereof. The cutting slot 122 is of a length

sufficient to extend across the proximal tibia 108, at a desired angle to the intramedullary canal, at the widest point of the proximal tibia 108, to allow the entire upper surface of the proximal tibia to be cut. The cutting slot 122 is of a size
5 sufficient to receive a cylindrical milling bit 155 such as that shown in FIG. 9. The milling bit 155 comprises central cutting portion 157 having helical cutting teeth along its length for cutting bone. The milling bit 155 further comprises spindles 156 extending from the central cutting portion 157 for supporting the
10 central cutting portion 157.

The milling bit 155 is inserted into and received in the cutting slot 122 through cutting slot entrance 124, along the direction shown by arrow A in FIG. 9. Note that the cutting slot entrance 124 may be of a wider slot area or an upturned portion of
15 the slot 122 or the milling bit 155 may merely be inserted and removed from the slot 122 at an end thereof. The spindles 156 extend through and coact with the lower cutting guide surface 123 and the upper retaining surface 125 of the cutting slot 122 to guide the milling bit 155 along the cutting slot 122 to resect the
20 proximal tibia 108, along the direction shown by arrow B in FIG. 2. At an end of one or both of the spindles 156 is a means for engaging the milling bit 155 with a drive means such as an electric drill, or other drive means. This engagement means may include a hexagonal head on one of the spindles, or any other
25 suitable method of engagement known in the art. Additionally, bushings may be employed, either on the milling bit 155 or captured by the cutting slot 122, to provide a non-metallic bearing between the spindles 156 of the milling bit 155 and the cutting slot 122 to avoid galling and to insure smooth
30 articulation of the milling bit 155 along the cutting slots 122. Importantly, the configuration of the milling bit 155 may be varied in accordance with what is known in the art, as long as the cutting device can follow the cutting path of the cutting slot to resect the proximal tibia. Additionally, it should also be
35 pointed out that other cutting tools may be used in accordance with present invention, including an oscillating or reciprocating saw or other means for resecting the tibia by following the

cutting slots on the cutting guides.

After the cutting guide clamps 110 are preliminarily located along the alignment rod 160, the cutting guides 120 are adjusted with respect to the clamp members 118 for proper anterior-posterior positioning to extend along the proximal tibia 108 for guiding the milling bit 155. Importantly, the cutting slots 122 should extend beyond the edges of the proximal tibia 108. Once proper anterior-posterior alignment is obtained, the cutting guides 120 may be locked into place on the clamp members 118.

Thereafter, a proximal tibial referencing stylus 190 may be attached to a referencing bracket 192 on the cutting guides 120. The referencing bracket 192 may be positioned in any location on the cutting guides 120, or on any other convenient component of the tibia resection system of the present invention. Alternatively, the referencing stylus 190 may be formed as part of a component of the present invention, or as a separate component which could function merely by contacting the cutting guides 120 of the present invention or any other component thereof. The referencing stylus 190 shown in FIG. 6 includes stylus body 194 which may be interconnected with the referencing bracket 192 in any manner known in the art, preferably by a quick release and connect mechanism or a threaded connection. The stylus body 194 supports a stylus arm 196, which is rotatable with respect to the stylus body 194 and configured to extend out and down from the stylus body 194 to contact the proximal tibia 108 at a tip 198 of the stylus arm 196. The stylus body 194, arm 196 and tip 198 are sized to contact the proximal tibia 108 to reference the positioning of the cutting guides 120 to cut the proximal tibia at a proper distance below the proximal tibia as is known in the art. The stylus arm 196 may include more than one tip 198, such other tips extending down from the stylus body 194 in varying distances.

In operation, one determines the desired location of the stylus tip 198, unlocks the cutting guide clamp linkage 170 to permit the linkage 170 to move up and down the alignment rod 160, and places the tip 198 on the lowest point of the proximal tibia to reference the position of the of the cutting guides with respect to the proximal tibia and with respect to the alignment

rod 160. Thereafter, the cutting guide clamp linkage 170 is locked to the alignment rod 160 to lock the cutting guides 120 into the proper position on the alignment rod 160, and accordingly, into proper position with respect to the proximal tibia. Thereafter, the hand grips 112 are actuated to press the cutting guides 120 against the proximal tibia to preliminarily lock them into position on the proximal tibia. Next, the cutting guides 120 are fixed to the proximal tibia by pins 136 or any other desired fixation means. The fixation block 180 can then be removed from the proximal tibia, and the proximal tibia may be resected.

Essentially, the cutting operation comprises inserting the milling bit 155 into the cutting guide slots 122 through the slot entrance/exit 124 to position the central cutting portion 157 between the cutting guides 120, the spindles 156 extending through the cutting guide slots 122. After the milling bit 155 is positioned, the drive means may be interconnected therewith, actuated, and the milling bit 155 moved along the cutting slots 122 to resect the proximal tibia.

It should be noted that a handle may be provided for attachment to the spindle which is not driven so that such spindle may be guided evenly through the cutting slots 122 to facilitate the cutting procedure. Alternatively, a handle can be provided which interconnects with both spindles to further facilitate control of the milling bit 155 during the cutting procedure. Additionally, the bushings that fit over the spindles 156 of milling bit 155 and ride in the cutting slots 122 may be captured in the ends of the handle and the milling bit received therethrough.

Additionally, it should be pointed out that it is within the scope of the present invention to modify the cutting slots 122 such that the upper retaining surface is eliminated, and the milling bit 155 merely follows the lower cutting guide surface 123. With the cylindrical milling bit 155 herein described, this is especially viable as the milling bit 155 tends to pull down into the bone as it is cutting, thereby primarily utilizing the lower cutting guide surface 123 of the cutting guide 120.

As shown in FIGS. 16-18, various other embodiments of the cutting guides are considered within the scope of the present invention. The cutting guide 220 shown in FIG. 16 is of a generally U-shaped configuration, having cutting guide slots 222, lower cutting guide surface 223, upper retaining surface 225, pin apertures 227 and alignment rod aperture 228. This cutting guide 220 is used in the same manner as the cutting guides hereinbefore described, the differences being that the cutting guide 220 interconnects directly with the alignment rod and that various size cutting guides must be provided to accommodate various sized tibias.

Likewise, the cutting guide 320 shown in FIG. 17 operates in the same manner as the cutting guide devices hereinbefore described, but it does not include cutting guide clamps. The cutting guide 320 includes cutting slots 322, and it interconnects directly with alignment rod by means of aperture 328. The distance between facing members 330 can be adjusted by moving base members 332 and 334 with respect to each other to size the cutting guide 320 for the tibia to be cut. Upon proper sizing, the base members 332 and 334 may be locked with respect to each other by set screw 336 or any other means known in the art.

FIG. 18 shows an embodiment of the cutting guide for use when the patellar tendon, the patella, or the quad tendon interferes with the placement of the other cutting guides of the present invention. As shown in FIG. 18, the cutting guide 420 may be directly interconnected with the alignment rod, and positioned on the tibia as hereinbefore set forth. Basically, this embodiment of the invention includes only one cutting guide. The cutting guide 420 and the cutting guide slot 422 may be wider than in the previous embodiments to help stabilize the milling bit in operation. In this embodiment, the milling bit may be first plunged across the tibia, and then moved therealong. The milling bit may be spring loaded to increase resistance as it is plunged through the cutting guide to bias the bit against being plunged too far across the tibia to cause damage to the tissue about the tibia. Additionally, a support member, not shown, could be provided to extend from the cutting guide 420, over and across the

tibia to the other side thereof where it could have a slot to capture the milling bit and provide additional support thereto.

Modifications of the foregoing may be made without departing from the spirit and scope of the invention. What is desired to be protected by Letters Patents is set forth in the appended claims.

5

CLAIMSWhat is claimed is:

1. A resecting system for resecting a distal human femur for receiving a distal femur prosthesis comprising:

5 positioning means for positioning a resecting apparatus on a distal human femur, the positioning means having a positioning body comprising:

 a front surface for contacting a human femur;

 a tongue extending from a lower end of the positioning body
10 for extending under a human femur;

 attachment means for attaching the positioning body to a distal human femur;

 angular adjustment means for adjusting the angle of the positioning means comprising:

15 an adjustment body;

 a rod extendable through the adjustment body and into a distal human femur;

 attachment means for attaching the angular adjustment means to the positioning means;

20 rotational alignment means for rotating the positioning means comprising:

 an alignment body;

 a shaft extending from the alignment body;

 attachment means for attaching the rotational alignment
25 means to the positioning means;

 pattern means for describing a resection pattern comprising:

 at least one pattern plate having a cutting path described therethrough, the cutting path matching an interior profile of a distal femoral prosthesis;

30 support means for supporting the at least one pattern plate;

 attachment means for attaching the support means to the rotational alignment means;

 fixing means for fixing the at least one pattern plate
35 to a side of a distal femur;

 cutting means extending through the cutting path of the pattern means, the cutting means movable along the cutting path

for cutting a distal femur to resect a distal femur.

2. The apparatus of the claim 1 wherein the pattern means includes two plates having cutting paths described therethrough, the patterned plates interconnected by the support means to straddle a distal femur.

3. The apparatus of claim 2 wherein the fixing means for fixing the pattern plates to a distal femur comprises cannulated screws extended through apertures in the pattern plates and fixation nails extendable through the cannulated screws into a distal femur.

4. The apparatus of claim 3 wherein the body of the positioning means further comprises a channel extending into the positioning body from a top surface of the positioning body.

5. The apparatus of claim 4 wherein the body of the angular adjustment means further includes wings sized to be received by the channel in the body of the positioning means.

6. The apparatus of claim 5 wherein the body of the rotational alignment means further includes wings sized to be received by the channel in the body of the positioning means.

7. The apparatus of claim 6 wherein the attachment means for attaching the support means to the rotational alignment means comprises an aperture in the support means for receiving the shaft of the rotational alignment means.

8. The apparatus of claim 7 wherein the cutting means comprises a cylindrical drill and the drill extends through the cutting paths in the pattern plates.

9. A system for resecting a femur comprising:
positioning means for contacting a femur;
support means interconnected with positioning means;
pattern means interconnected with the support means, the pattern means positioned along a side of a femur;

cutting path means described in the pattern means, the cutting path means matching an interior profile of a distal femoral prosthesis; cutting means coacting with the cutting path means for cutting a distal femur.

10. The apparatus of claims 9 further comprising an intramedullary rod insertable into a femur, the intramedullary rod

interconnected with the positioning means to align the positioning means with respect to a femur.

5 11. The apparatus of claim 10 wherein the intramedullary rod includes at least one groove extending helically along the length of the intramedullary rod.

12. The apparatus of claim 9 wherein the pattern means comprises at least one pattern plate having a cutting path described therethrough.

10 13. The apparatus of claim 9 wherein the pattern means comprises opposing pattern plates positioned to straddle a femur, with matching cutting paths described therethrough.

14. The apparatus of claim 11 further including an alignment means for receiving the intramedullary rod, the alignment means interconnected with the positioning means.

15 15. The apparatus of claim 14 wherein the positioning means further comprises a channel extending into the positioning means from an upper surface thereof.

20 16. The apparatus of claim 15 wherein the alignment means further includes wings sized to be received by the channel in the positioning means.

25 17. The apparatus of claim 16 wherein the cutting means comprises a cylindrical drill extending through the cutting path means and movable along the cutting path means after the positioning means and the adjustment means are removed from a femur.

18. A method for resecting a human femur comprising the steps of:

inserting a rod through an adjustment block into a human femur;

30 attaching a positioning block to the alignment block;

affixing the positioning block to a human femur;

interconnecting a rotational alignment device to the positioning block;

35 interconnecting a support means with the rotational alignment device, the support means supporting pattern plates having cutting paths described therethrough;

positioning the pattern plates along sides of a femur;
affixing the pattern plates to a femur;
removing the positioning block, the alignment device and the
adjustment block from the support means;

5 inserting a cutting means through the cutting paths described
in the pattern plates; and

tracing the cutting means along the cutting paths described
in the pattern plates to resect a femur.

19. The method of claim 18 further comprising the step of
0 employing the adjustment block to adjust the positioning block
with respect to a human femur.

20. The method of claim 19 further comprising the step of
using the rotational alignment device to align of the support
means, and the pattern plates, with the positioning block.

5 21. An apparatus for resecting a proximal human tibia
comprising:

alignment means having proximal and distal ends;

0 distal attachment means for attaching to a tibia, the distal
attachment means interconnected with the distal end of the
alignment means;

fixation means for attachment to the proximal tibia, the
fixation means interconnected with the proximal end of the
alignment means for aligning the alignment means;

5 cutting guide means interconnected with the alignment means,
the cutting guide means including a guide surface and fixation
means for affixing the cutting guide means to a tibia; and

milling means for cutting a tibia, the milling means coacting
with the guide surface of the cutting guide means for resecting a
tibia.

0 22. The apparatus of claim 21 wherein the guide surface of
the cutting guide means is located within a cutting guide slot
formed in the cutting guide means, the cutting guide slot
receiving and guiding the milling means for resecting a tibia.

5 23. The apparatus of claim 22 wherein the guide surface of
the cutting guide slot defines a linear path.

24. The apparatus of claim 23 wherein cutting guide means
comprises two members in opposing relationship having

corresponding cutting guide slots therein for receiving and guiding the milling means for resecting a tibia.

25. The apparatus of claim 24 wherein the cutting guide slots further include an entrance area for receiving the milling means comprising an enlarged slot area at an end of the guide slots.

26. The apparatus of claim 24 wherein the cutting guide slots further include an entrance area for receiving the milling means comprising an upturned slot area at an end of the guide slots.

27. The apparatus of claim 26 wherein the cutting guide means further comprise hand grips, mating cross bars having pivot apertures and clamp members, the cutting guide means adjustably interconnected with the clamp members.

28. The apparatus of claim 27 further including cutting guide linkage means for interconnecting the cutting guide means with the alignment means, the cutting guide linkage means comprising an aperture for receiving the alignment rod and a post for inserting through the pivot apertures of the mating cross bars of the cutting guide means.

29. An apparatus for resecting a proximal tibia comprising:
hand grip means in opposing relationship for manipulating the apparatus;

opposing clamp members corresponding to the handgrip means for adjustably receiving cutting guide means;

cross bar members for interconnecting the hand grip means with opposite opposing clamp members, the cross bar members including a cross over point having corresponding pivot apertures with a shaft therein for pivoting the cross bar members with respect to each other, to move the clamp members with respect to each other upon manipulation of the hand grip means;

fixation means for affixing the cutting guide means to a proximal tibia; and

guide surfaces in the cutting guide means for guiding a cutting device across a tibia.

30. The apparatus of claim 29 wherein the guide surfaces of the cutting guide means are located within cutting guide slots

formed in the cutting guide means, the cutting guide slots receiving and guiding a milling means for resecting a tibia.

31. The apparatus of claim 30 wherein the guide surfaces of the cutting guide slots define a linear path.

5 32. The apparatus of claim 31 wherein the cutting guide slots further include an entrance area for receiving the milling means comprising an enlarged slot area at an end of the guide slots.

10 33. The apparatus of claim 31 wherein the cutting guide slots further include an entrance area for receiving the milling means comprising an upturned slot area at an end of the guide slots.

15 34. The apparatus of claim 33 further including cutting guide linkage means for interconnecting the cutting guide means with the alignment means, the cutting guide linkage means comprising an aperture for receiving the alignment rod and a shaft for inserting through the pivot apertures of the cross bars of the cutting guide means.

20 35. A method for resecting a proximal tibia comprising the steps of:

attaching an ankle clamp about an ankle;

interconnecting an alignment rod at a distal end thereof with the ankle clamp;

25 interconnecting a fixation head with a proximal end of the alignment rod;

partially attaching the fixation head to the proximal tibia;

aligning the alignment rod;

completely attaching the fixation head to the proximal tibia;

30 interconnecting cutting guide clamps with the alignment rod; positioning the cutting guide clamps about the proximal tibia;

securing the cutting guide clamps to the tibia at a proper location;

35 removing the fixation head from the tibia; and

cutting the proximal tibia with a milling bit.

36. The method of claim 35 wherein the step of interconnecting the cutting guide clamps with the alignment rod further includes the steps of:

5 positioning a cutting guide linkage along the alignment rod;
and

interconnecting the cutting guide clamps with the cutting guide linkage by means of locating pivot apertures in the cutting guide clamps onto a pivot shaft formed on the cutting guide linkage.

10 37. The method of claim 36 wherein the step of positioning the cutting guide clamps about the proximal tibia comprises manipulating hand grips interconnected with the cutting guide clamps to move the cutting guide clamps against the proximal tibia.

15 38. The method of claim 37 wherein the step of positioning the cutting guide clamps about the proximal tibia further includes the step of adjusting the cutting guide clamps with respect to cutting guide members extending from the hand grips.

20 39. The method of claim 38 wherein the step of cutting the proximal tibia with a milling bit comprises the steps of:

inserting the milling bit into guide slots formed in the cutting guide clamps;

engaging the milling bit with drive means;

capturing ends of the milling bit with handle means; and

25 guiding the milling bit through the guide slots in the cutting guide clamps to resect the proximal tibia.

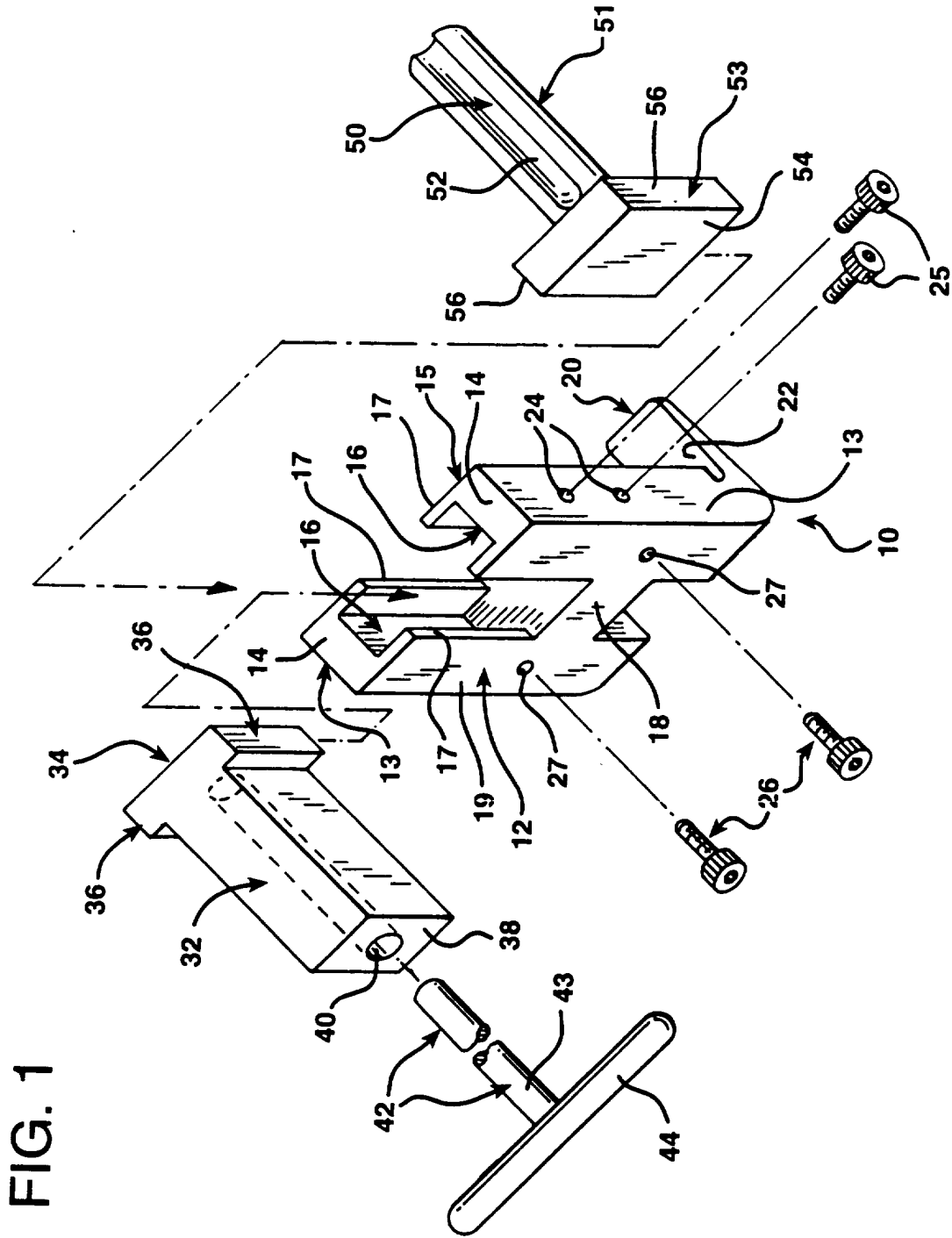
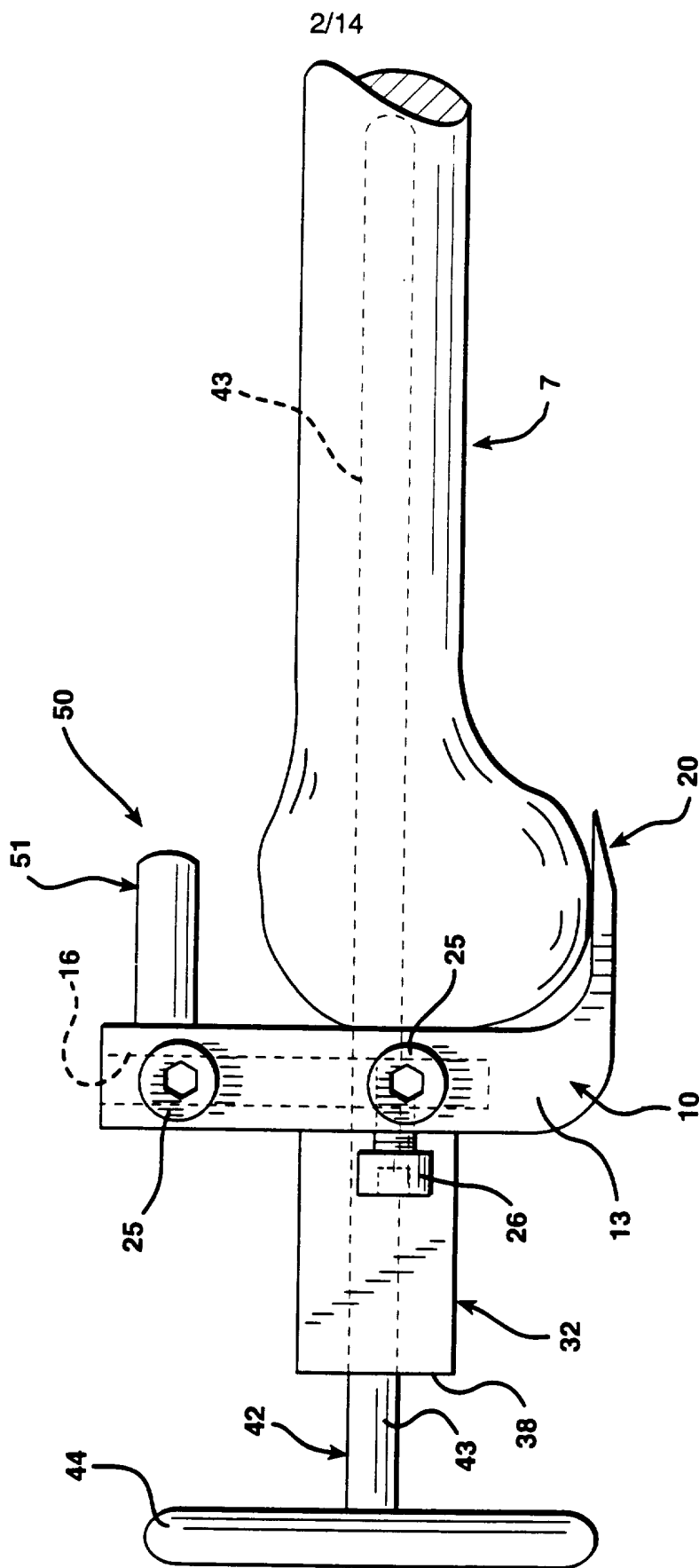

FIG. 1

FIG. 2



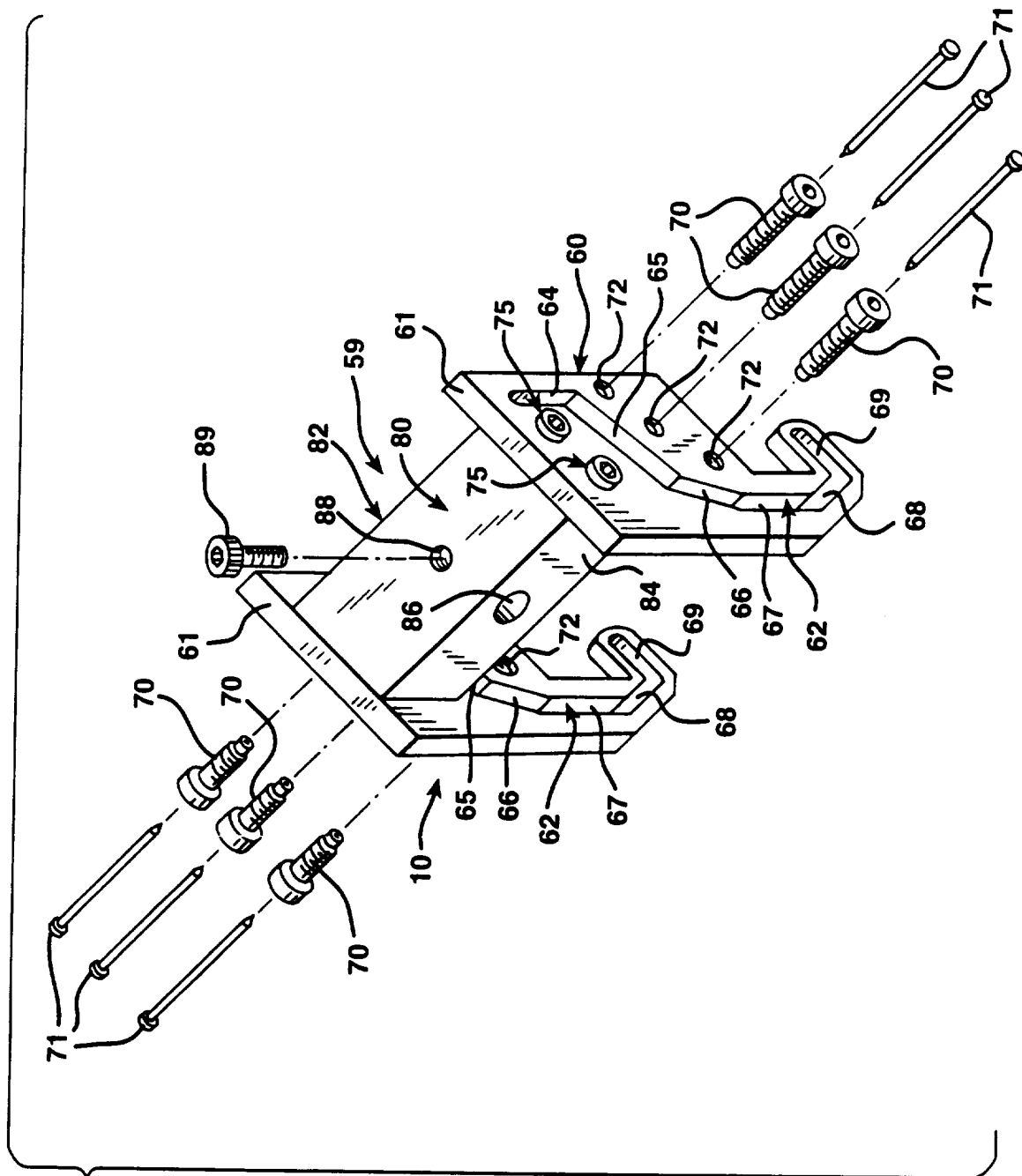

FIG. 3

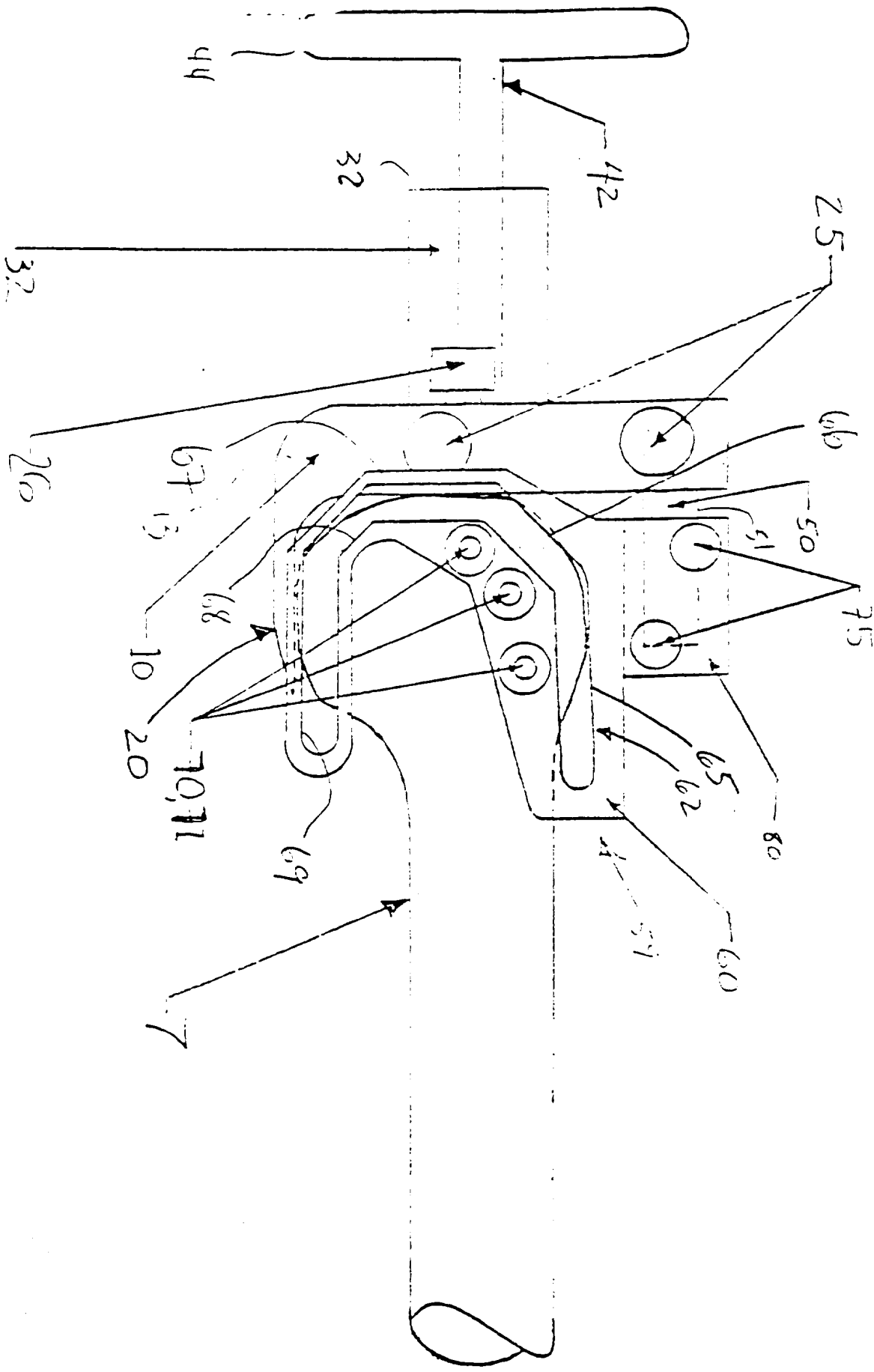

FIG. 5

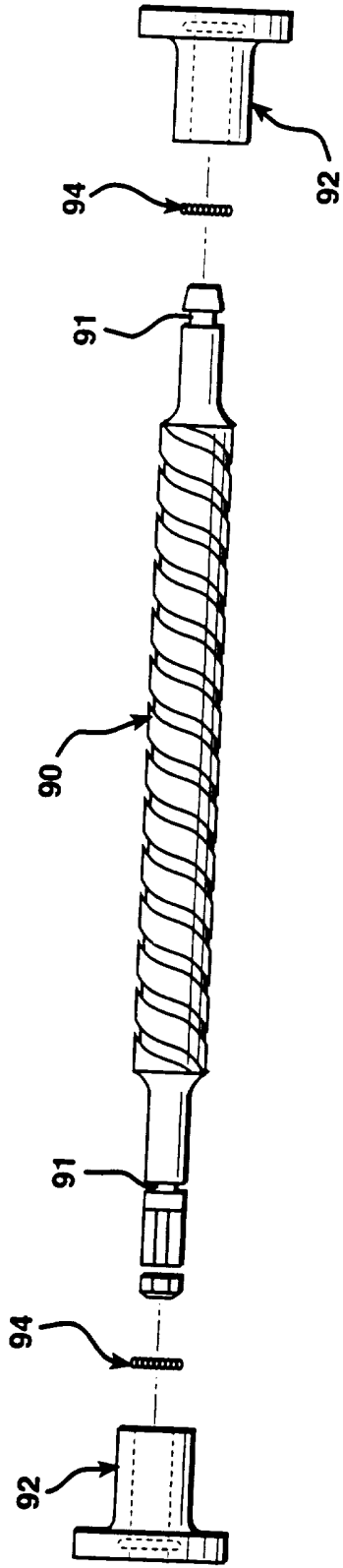
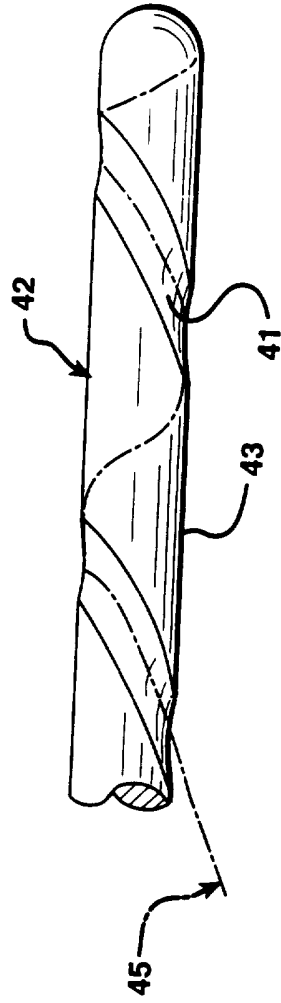

FIG. 7



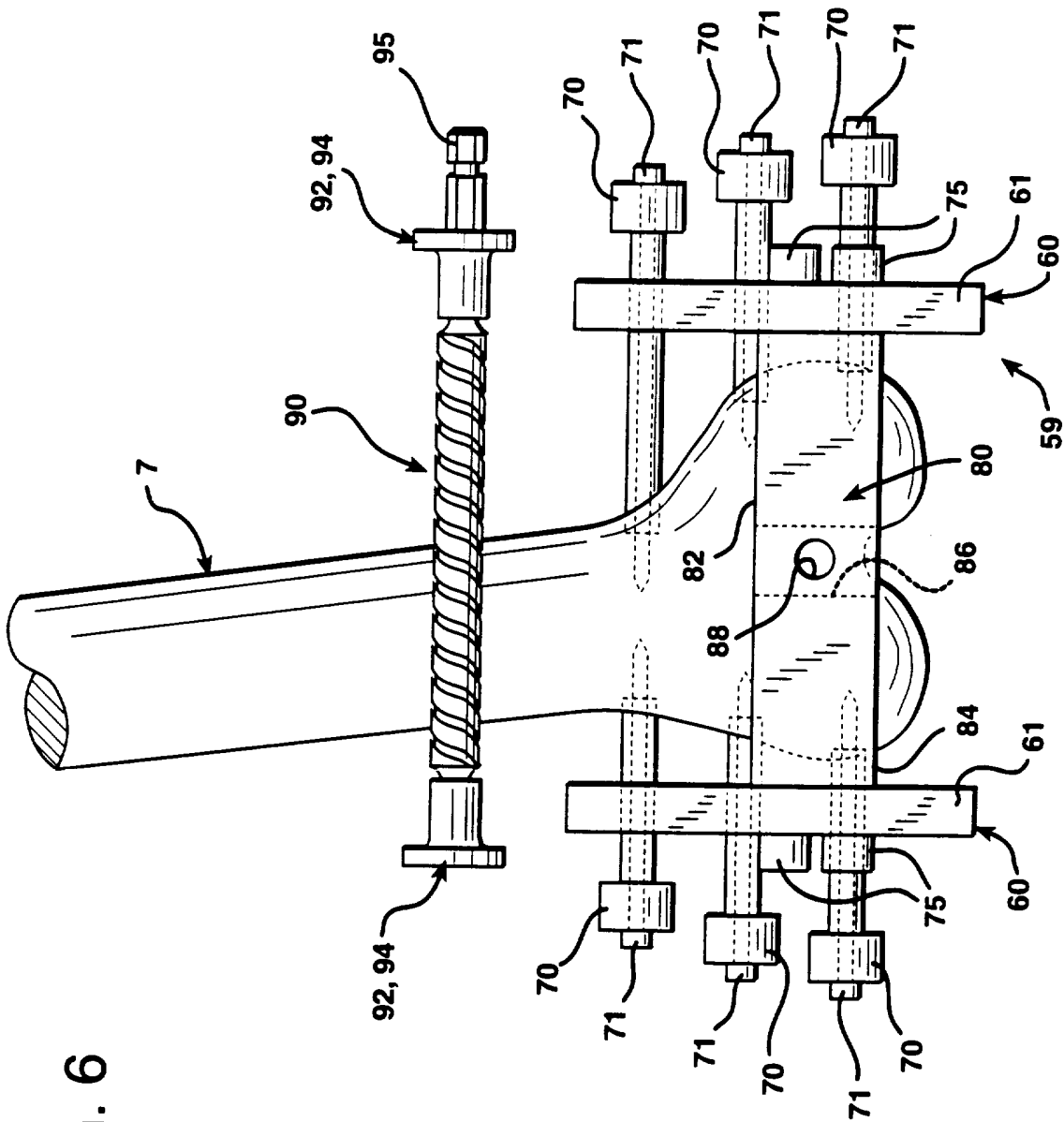

FIG. 6

FIG. 8

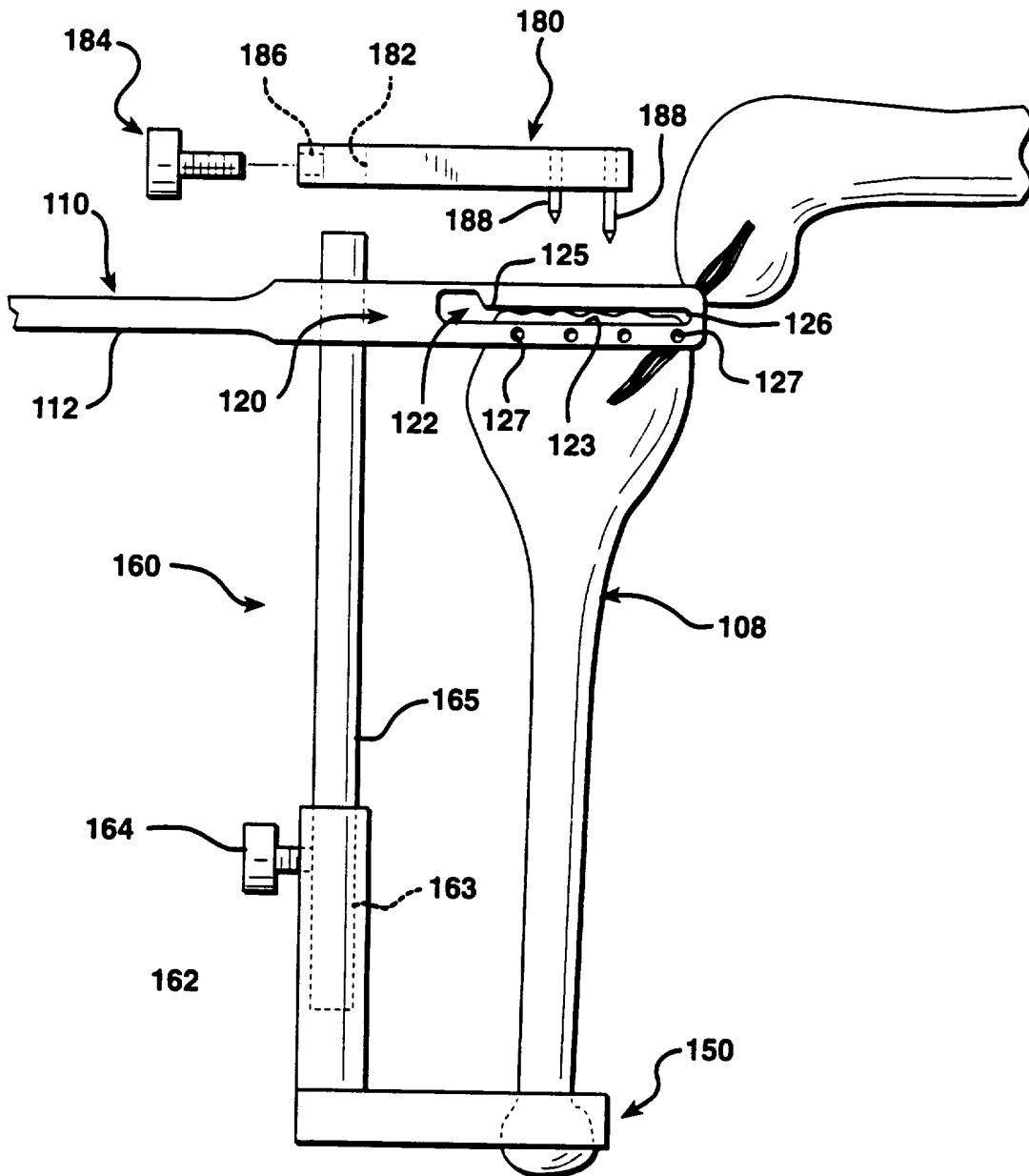

FIG. 9

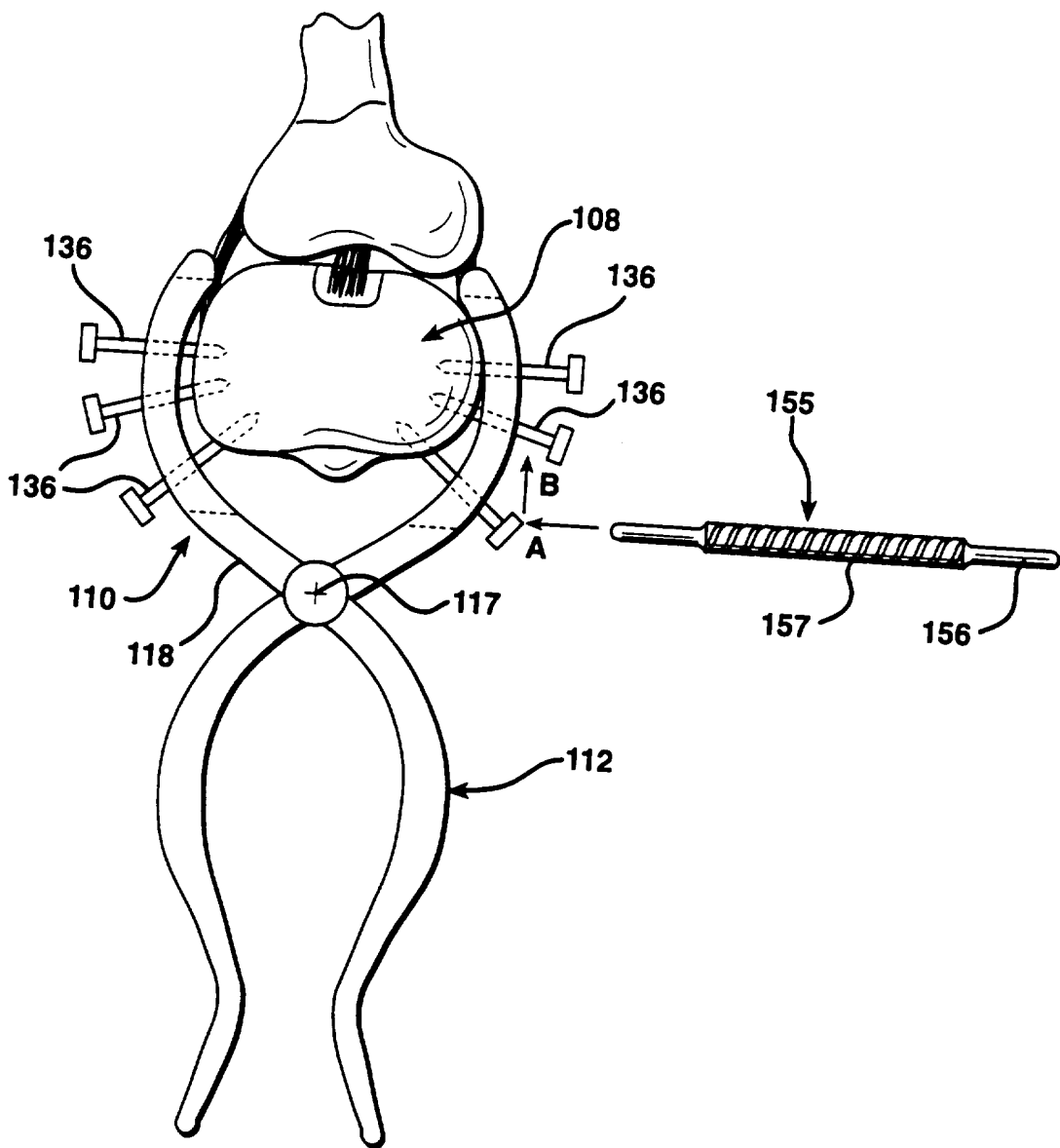
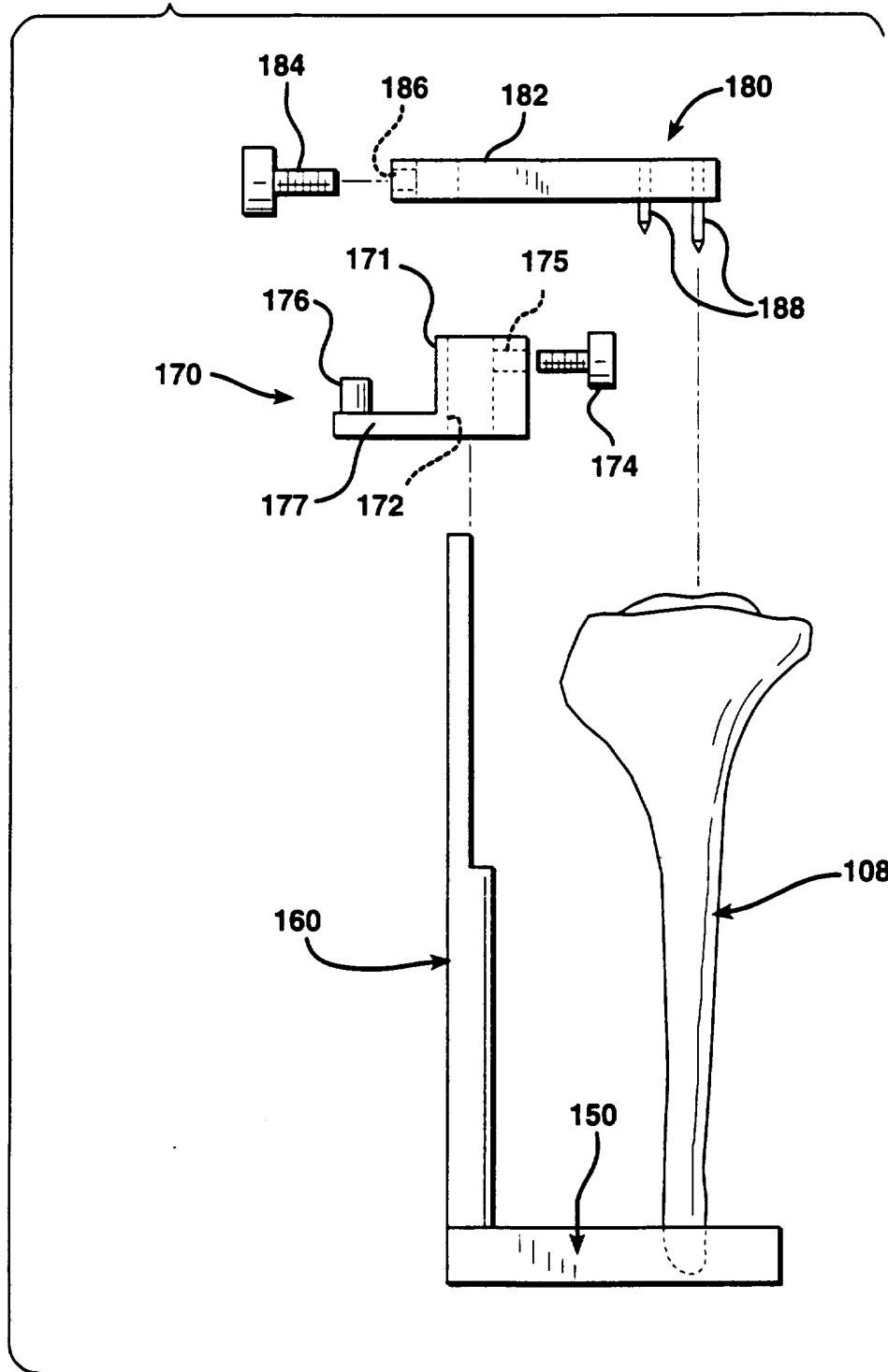

FIG. 10



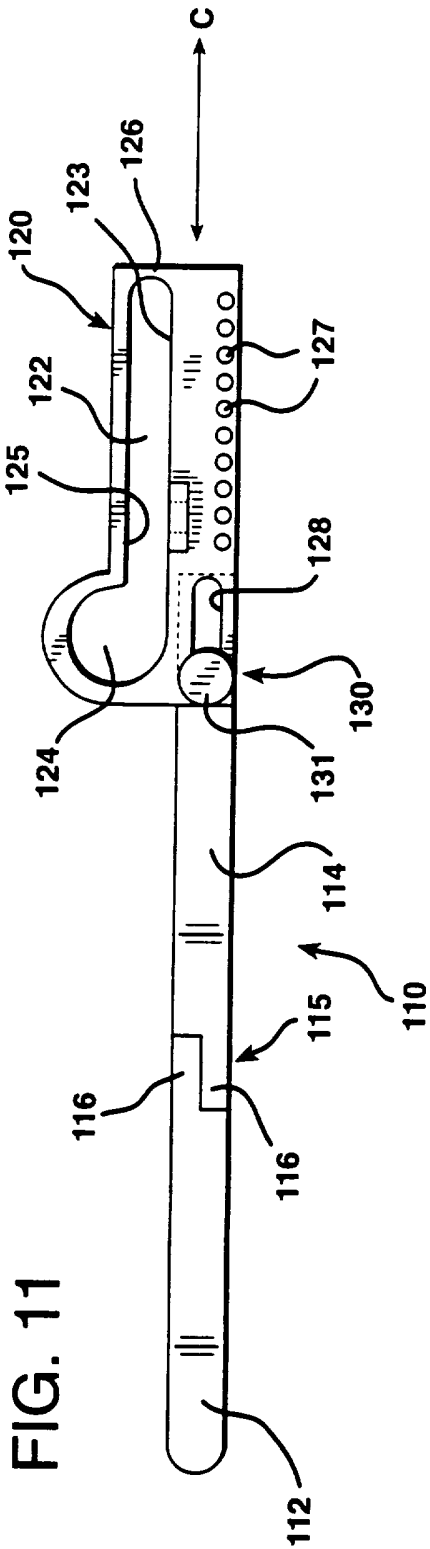

FIG. 11

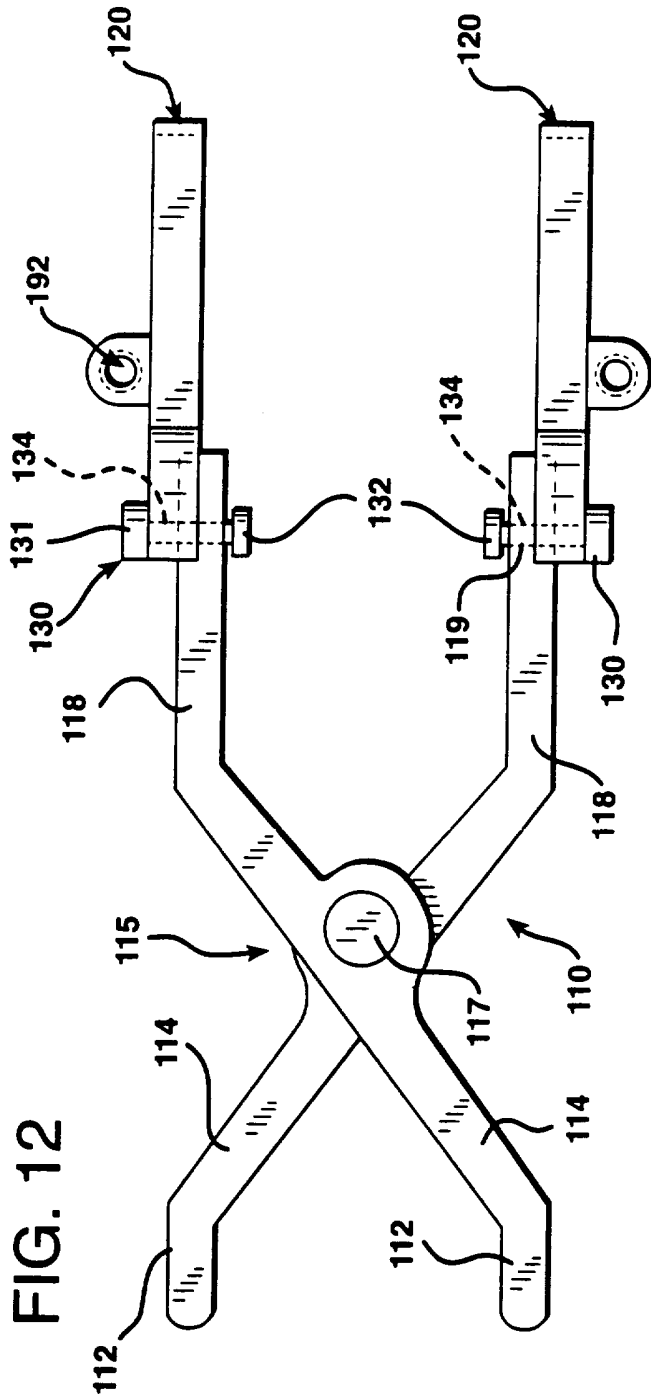

FIG. 12

FIG. 13

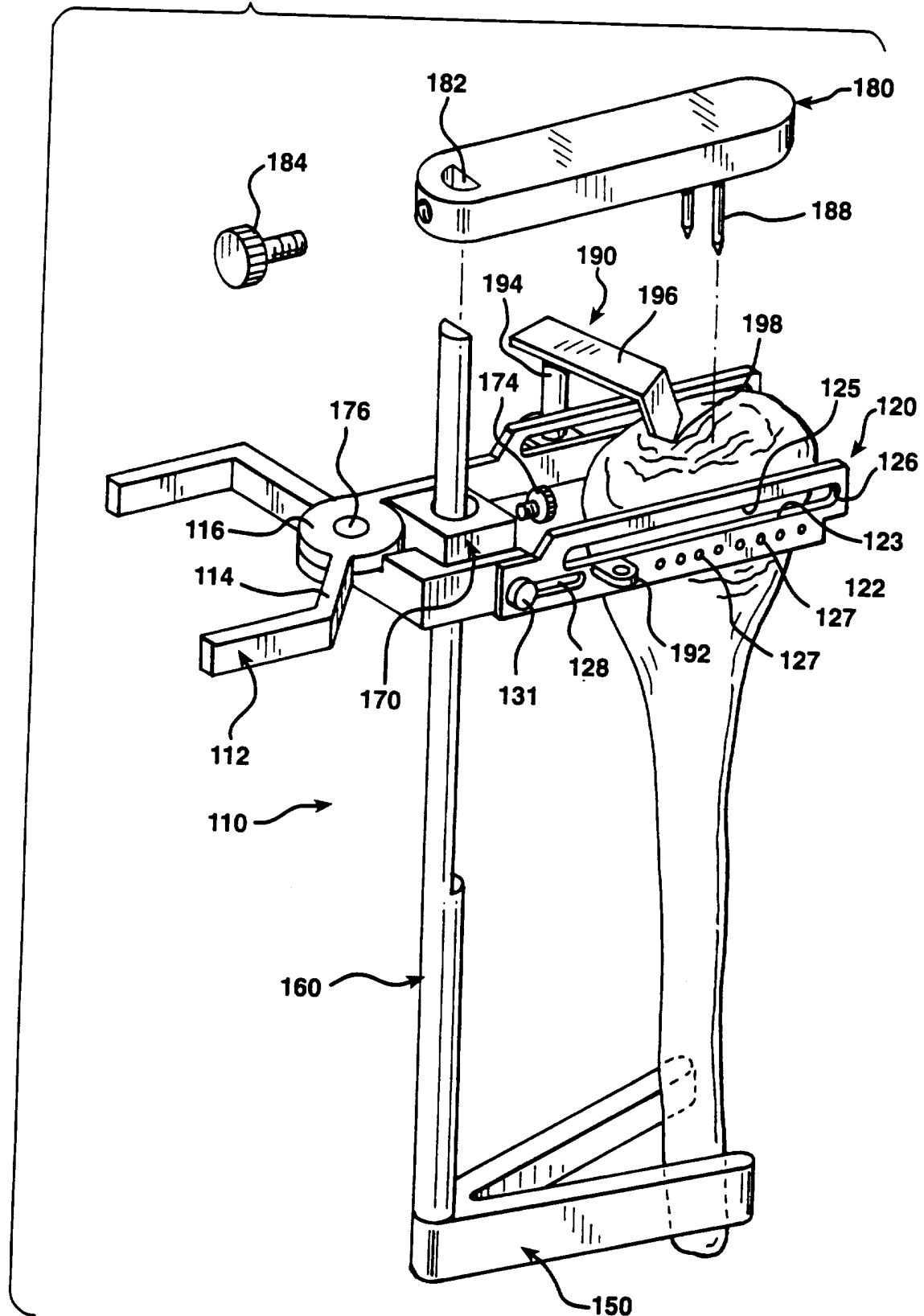

FIG. 14

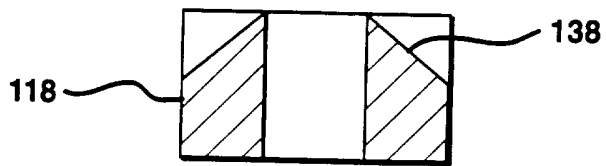

FIG. 15

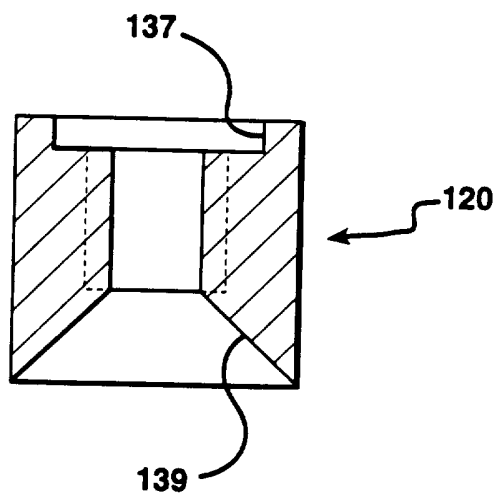

FIG. 16

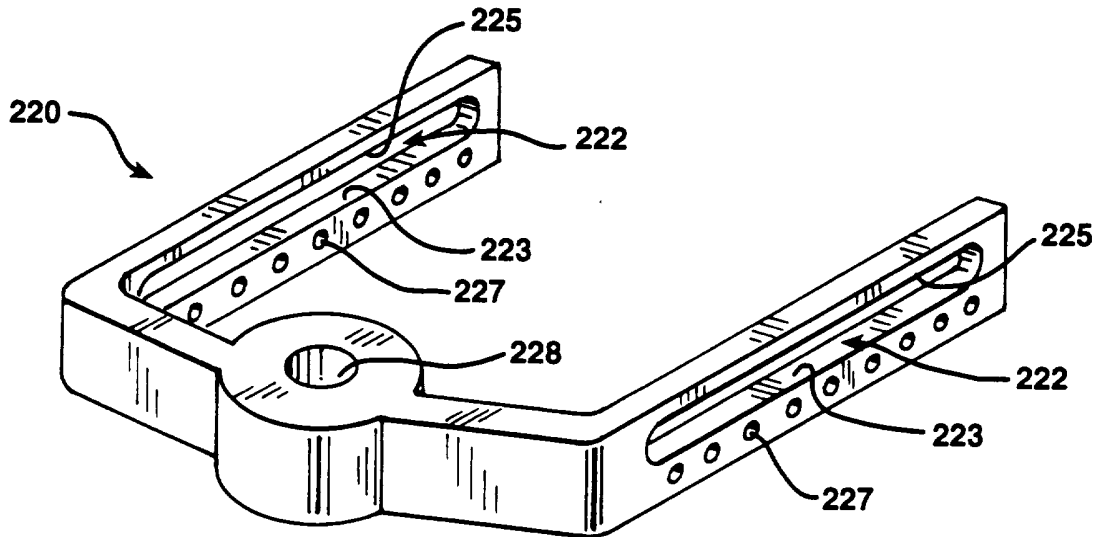

FIG. 18

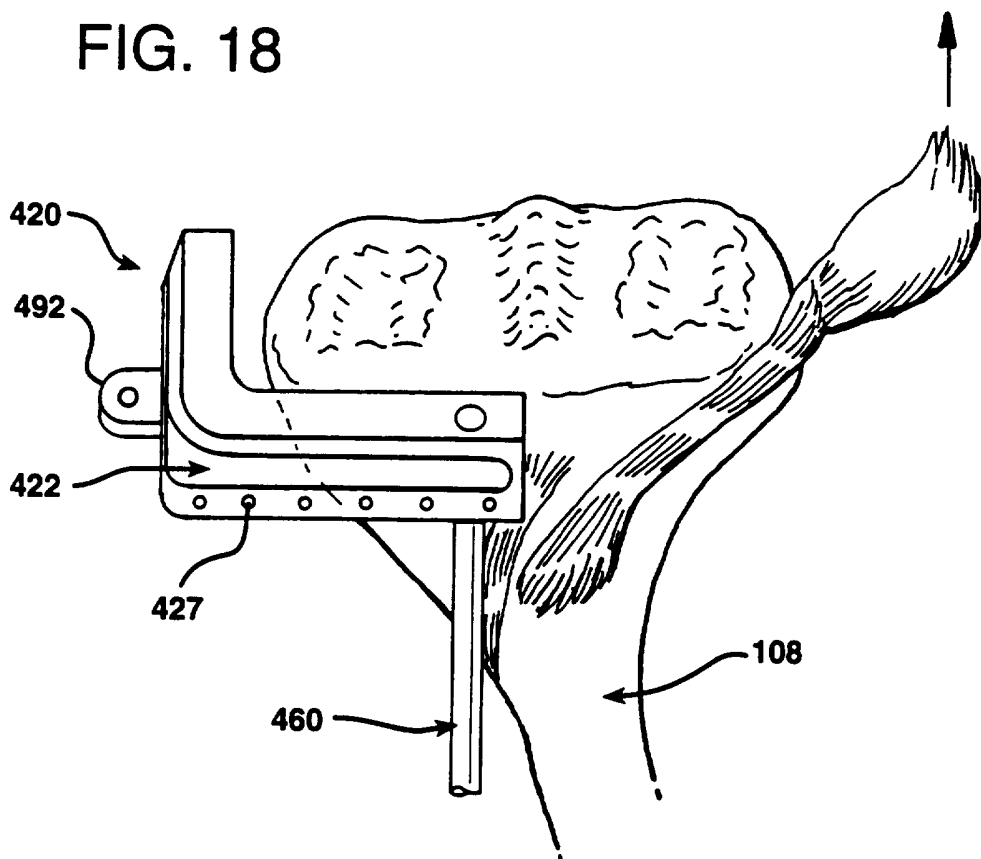
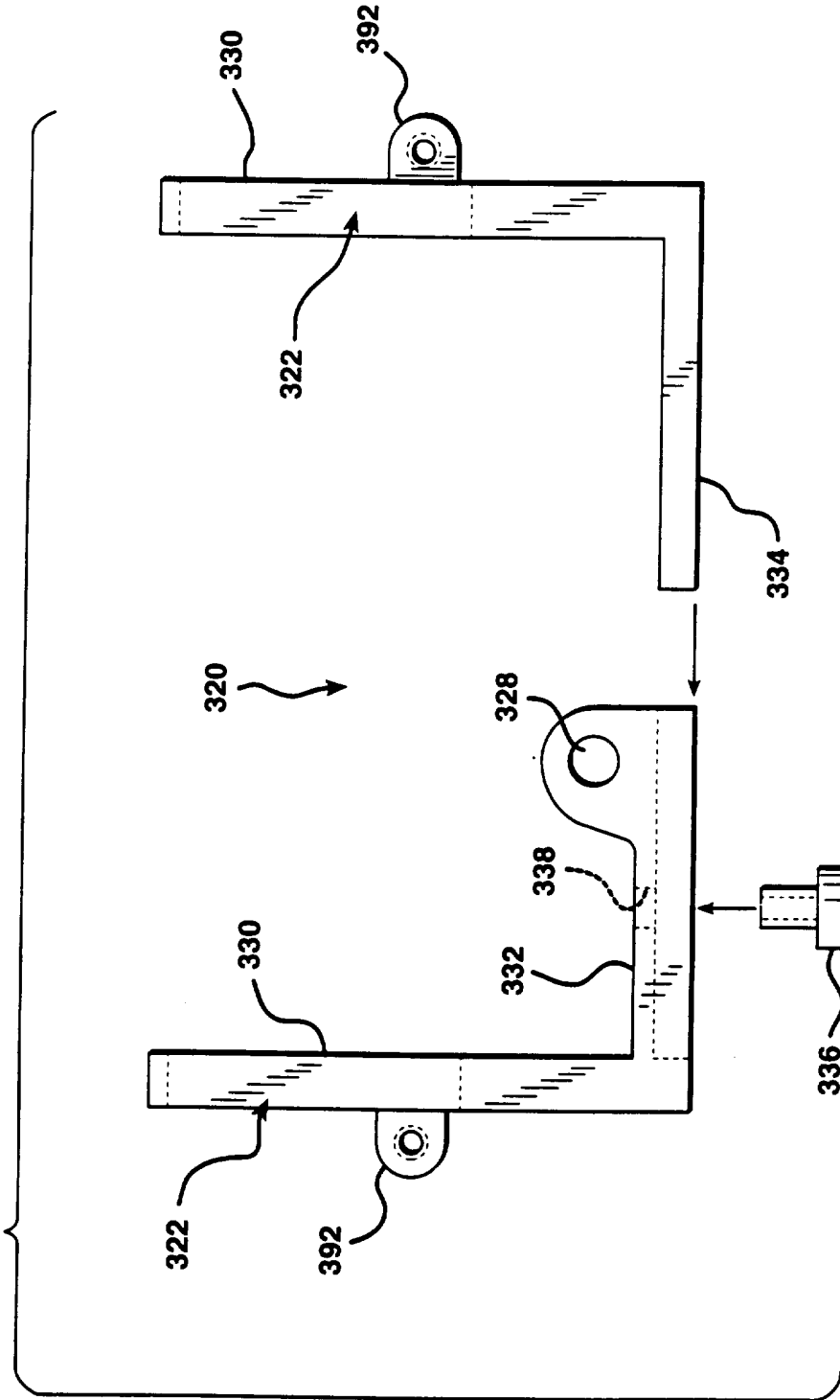

FIG. 17



INTERNATIONAL SEARCH REPORT

International application No.

PCT/US95/11120

A. CLASSIFICATION OF SUBJECT MATTER

IPC(6) :A61B 17/56

US CL :606/88

According to International Patent Classification (IPC) or to both national classification and IPC

B. FIELDS SEARCHED

Minimum documentation searched (classification system followed by classification symbols)

U.S. : 606/88, 90, 79, 80, 82, 86, 87, 89, 96, 102

Documentation searched other than minimum documentation to the extent that such documents are included in the fields searched

none

Electronic data base consulted during the international search (name of data base and, where practicable, search terms used)

none

C. DOCUMENTS CONSIDERED TO BE RELEVANT

Category*	Citation of document, with indication, where appropriate, of the relevant passages	Relevant to claim No.
X	EP, A, 538153 (Collomb et al.) 21 April 1993, see figure 1.	1,9,10,12
<u>Y</u>		<u>11,14-16</u>
Y	US, A, 5,053,037 (Lackey) 01 October 1991, see figure 13.	11,14-16
Y	EP, A, 466,659 (Ghissellini) 15 January 1992, see figure 2.	16
X	US, A, 5,147,365 (Whitlock et al.) 15 September 1992, see figure 1.	29-31
A	US, A, 5,306,276 (Johnson et al.) 26 April 1994, see figure 1.	21-28, 35-39

Further documents are listed in the continuation of Box C.

See patent family annex.

* Special categories of cited documents:	"T"	later document published after the international filing date or priority date and not in conflict with the application but cited to understand the principle or theory underlying the invention
"A" document defining the general state of the art which is not considered to be part of particular relevance	"X"	document of particular relevance; the claimed invention cannot be considered novel or cannot be considered to involve an inventive step when the document is taken alone
"E" earlier document published on or after the international filing date	"Y"	document of particular relevance; the claimed invention cannot be considered to involve an inventive step when the document is combined with one or more other such documents, such combination being obvious to a person skilled in the art
"L" document which may throw doubts on priority claim(s) or which is cited to establish the publication date of another citation or other special reason (as specified)	"A"	document member of the same patent family
"O" document referring to an oral disclosure, use, exhibition or other means		
"P" document published prior to the international filing date but later than the priority date claimed		

Date of the actual completion of the international search

13 NOVEMBER 1995

Date of mailing of the international search report

20 DEC 1995

Name and mailing address of the ISA/US
Commissioner of Patents and Trademarks
Box PCT
Washington, D.C. 20231

Facsimile No. (703) 305-3230

Authorized officer

GUY TUCKER

Telephone No. (703) 308-0858