

G. S. KNAPP.  
 METAL COVE MOLDING AND FITTINGS.  
 APPLICATION FILED SEPT. 7, 1915.

1,250,594.

Patented Dec. 18, 1917.

2 SHEETS—SHEET 1.

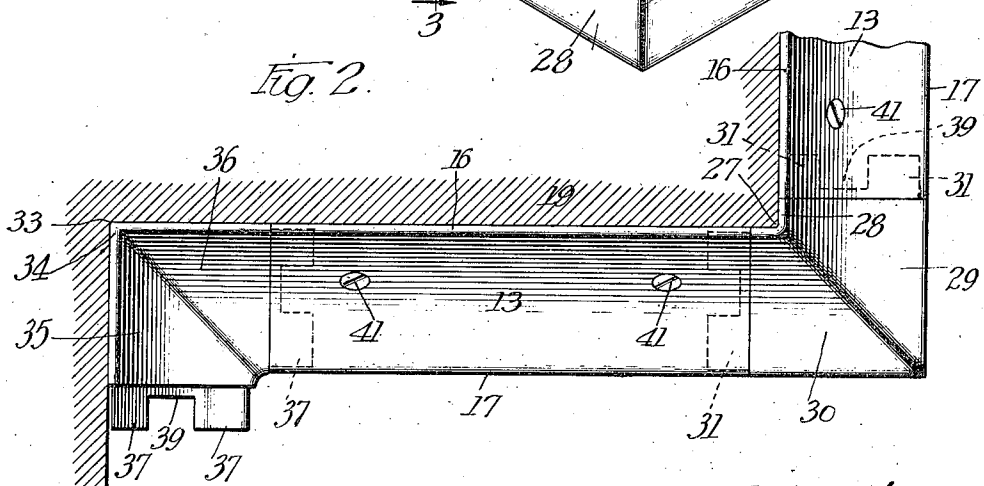
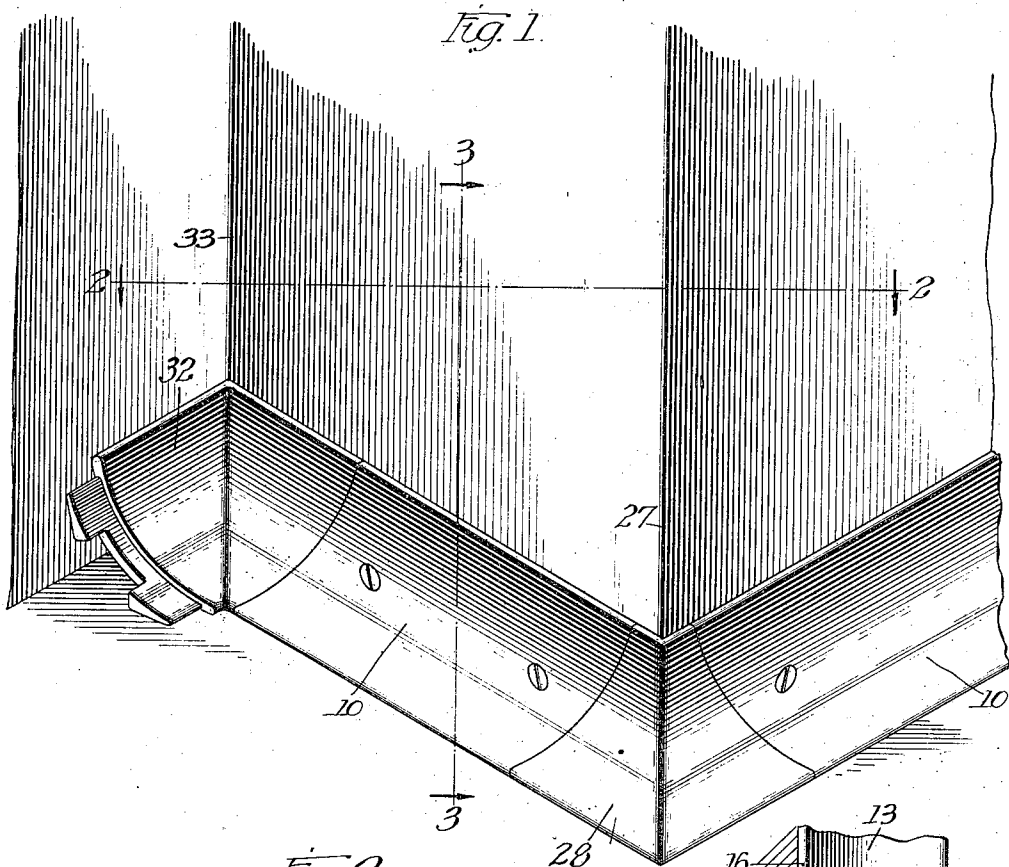

Witnesses:  
 Robert Weir  
 Arthur W. Carney

Inventor  
 George S. Knapp  
 Jones & Rainey  
 Attys.

G. S. KNAPP.  
 METAL COVE MOLDING AND FITTINGS.  
 APPLICATION FILED SEPT. 7, 1915.

1,250,594.

Patented Dec. 18, 1917.  
 2 SHEETS—SHEET 2.

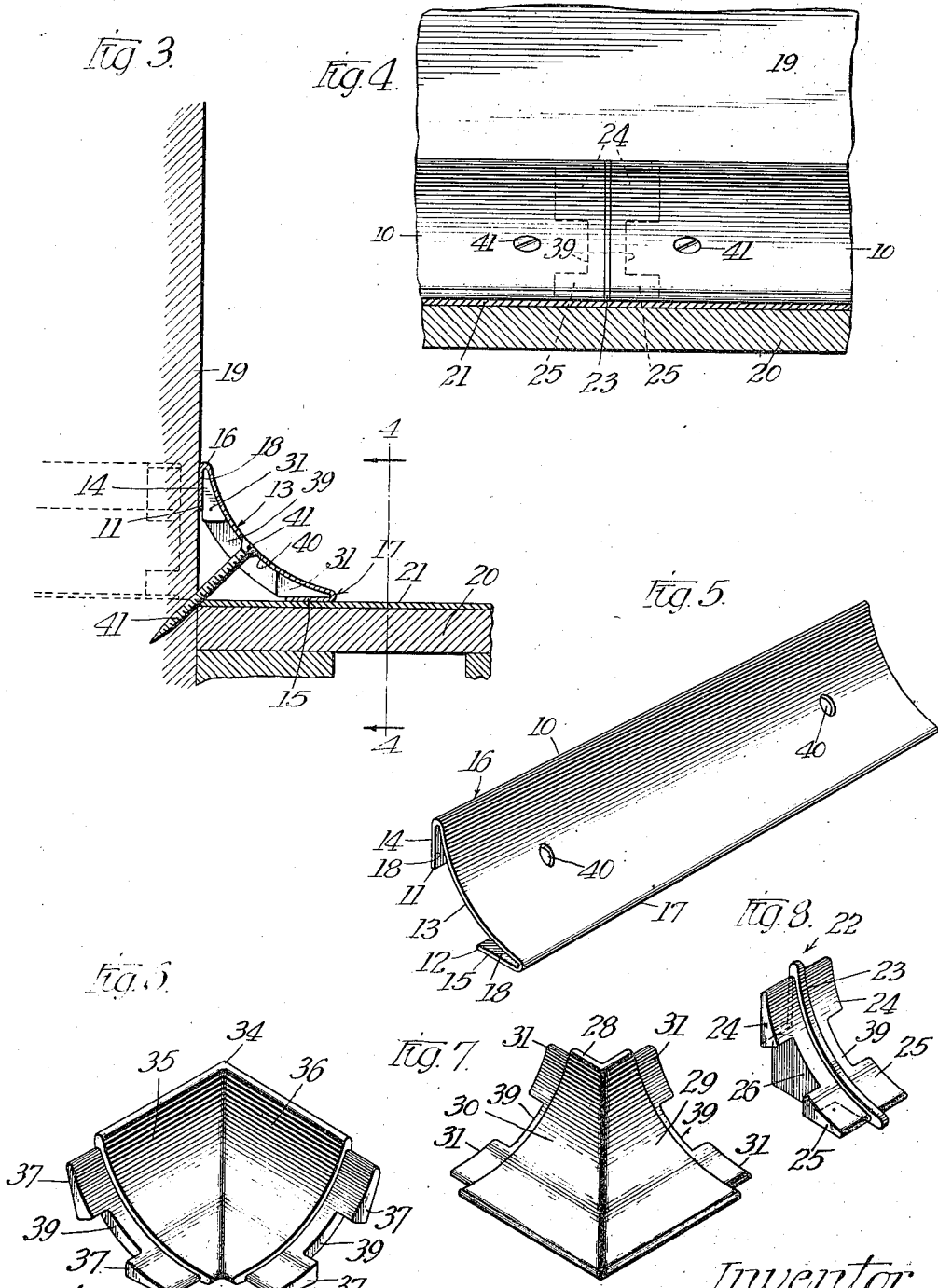

Witnesses:  
 Robert Weir  
 Arthur W. Carboy

Inventor:  
 George S. Knapp  
 Fonee Rain May  
 attys.

# UNITED STATES PATENT OFFICE.

GEORGE S. KNAPP, OF LA GRANGE, ILLINOIS, ASSIGNOR TO KNAPP BROTHERS MANUFACTURING COMPANY OF CHICAGO, ILLINOIS, OF CHICAGO, ILLINOIS, A CORPORATION OF ILLINOIS.

## METAL COVE-MOLDING AND FITTINGS.

1,250,594.

Specification of Letters Patent. Patented Dec. 18, 1917.

Application filed September 7, 1915. Serial No. 49,311.

To all whom it may concern:

Be it known that I, GEORGE S. KNAPP, a citizen of the United States, residing at La Grange, in the county of Cook and State of Illinois, have invented certain new and useful Improvements in Metal Cove-Moldings and Fittings, of which the following is a specification.

My invention relates to metal cove molding and fittings therefor whereby to join molding sections together and to attach or secure same in place.

One of the objects of my invention is to provide a sheet metal cove molding, having no exposed raw edges, designed to bridge the corners of angularly related walls, such as a side wall and the floor or ceiling of a room, and fittings whereby to join or continue adjacent sections of molding.

Another object of my invention is to generally improve devices of this character.

Other and further objects of my invention will become readily apparent, to persons skilled in the art, from a consideration of the following description when taken in conjunction with the drawings, wherein:—

Figure 1 shows an elevation of the side walls of a part of a room and an inner and outer vertically extending corner thereof, with the molding in place, bridging the meeting points or corners between the vertical walls and the floor of the room.

Fig. 2 is a sectional plan view, taken on line 2—2 of Fig. 1.

Fig. 3 is a section taken on line 3—3 of Fig. 1.

Fig. 4 is a section taken on line 4—4 of Fig. 3.

Fig. 5 is a perspective view of a part of a section of the molding.

Fig. 6 is a section-joining fitting for an inner vertical corner.

Fig. 7 is a section-joining fitting for an outer vertical corner.

Fig. 8 is a fitting for adjoining proximate ends of adjacent molding sections together.

In all the views the same reference characters are employed to indicate similar parts.

A molding section 10 is composed of a strip of sheet metal having its raw edges, as 11 and 12, out-turned, so as to occupy planes substantially at right angles to each other and the intermediate body portion 13 transversely curved to present a concaved

surface. The wall 14, of the inturned edge 11, is practically perpendicular to the wall 15 thereby providing a quarter round concave molding or cove. The salient edges 16 and 17 are smooth and present finished smooth surfaces to the observer.

Between the inturned portions 14 and 15 and the curved body portion 13 of the structure are provided, pockets 18.

The molding is especially intended for bridging the meeting angles or corners of the vertical walls 19 and the horizontal floor 20, of a room. The molding also serves to hold the floor covering 21, such as matting, oil-cloth, linoleum or the like in place.

Adjacent molding sections 10 are joined together by a fitting 22 which is, preferably, a casting and which has a surface 23 that is in substantially the same plane as or is flush with the outside surface 13 of the molding and is provided with laterally extending fins or parts 24 and 25 for inclusion in the pockets 18. The fitting 22 may, when used as a terminal, also have a rectangular portion 26 that fits into the corner provided by the vertical and horizontal walls in which case it will have fins projecting from one edge only. Where the molding is intended to go around an outer corner, such as corner 27, shown in Fig. 1, a fitting 28 is employed which consists of angularly related, integral main body portions presenting the contours 29 and 30, substantially flush with the outside surface 13 of the molding section, when in place, and laterally projecting fins 31 for inclusion in the pockets 18 of the molding section.

A somewhat similar, but reversed fitting 32 is intended for the inner corner 33, of a room, and consists of the main body portion 34 having concaved angularly related integral surfaces 35 and 36, corresponding with the surface 13 of the molding strip, and having similar, laterally disposed fins 37, for inclusion in the pockets 18 of the molding strip.

Intermediate the fins 37, and of similar fins of the other fittings, is a portion 39 affording a backing for the intermediate curved portion of the strip.

Each of the strips 10 is perforated, at intervals, to receive attaching screws 40, at intervals, to receive attaching screws 41. The perforations 40 may be counter-sunk so that the tapered head of the screw

41 will be substantially flush with the curved surface 13 of the strip.

The fittings 22, 28 and 34 are preferably placed in position, with reference to adjacent sections of molding 10, before the structure, as a whole, is secured in place by the screws 41, the fittings as well as the molding being held in place by said screws.

The molding affords a sanitary finish around the outer edges or corners of a room, preventing accumulation of dirt in the corners and is a means by which the edges of the floor covering may be held in place.

While I have herein shown a single embodiment of my invention, for the purpose of clear disclosure, it is manifest that changes may be made in the general form and arrangement of the parts within the scope of the appended claims.

Having described my invention, what I claim is:—

1. A cove molding for contact with the floor and wall on lines spaced away from the juncture of the floor and wall and comprising a strip of sheet metal having its intermediate body part transversely curved and its longitudinal marginal portions turned back into planes substantially at right angles to each other leaving a space between the opposite edges thereof and fastening means taking through the interme-

diate body part at approximately the mid-point of the curvature.

2. A cove molding structure comprising a strip of sheet metal for contact with the floor and wall on lines spaced away from the juncture of the floor and wall, said strip having its intermediate body part transversely curved convexly and its longitudinal marginal portions turned back into planes at substantially right angles to each other, leaving a space between the opposite edges thereof, a fitting having a body part shaped to provide a continuation of the exposed portion of the strip, and having transversely separated laterally extending parts for projection within the transversely curved strip and fastening means taking through the intermediate body part at approximately the mid-point of the curvature.

3. A cove strip curved transversely as at 13 having its marginal edges turned back and terminating as at 11 and 12 respectively and having the portions 14 and 15 in planes at substantial right angles to each other.

In testimony whereof I hereunto set my hand in the presence of two subscribing witnesses.

GEORGE S. KNAPP.

In the presence of—  
FORÉE BAIN,  
MARY F. ALLEN.