

Textile Printing

Second Edition

Edited by Leslie W C Miles

Formerly Lecturer in Textile Chemistry, Department of Textiles, University of Manchester Institute of Science and Technology, Manchester, UK

1994

Society of Dyers and Colourists

Copyright © 1994 Society of Dyers and Colourists. All rights reserved. No part of this publication may be reproduced, stored in a retrieval system or transmitted in any form or by any means without the prior permission of the copyright owners.

Published by the Society of Dyers and Colourists, PO Box 244, Perkin House, 82 Grattan Road, Bradford, West Yorkshire BD1 2JB, England, on behalf of the Dyers' Company Publications Trust.

This book was produced under the auspices of the Dyers' Company Publications Trust. The Trust was instituted by the Worshipful Company of Dyers of the City of London in 1971 to encourage the publication of textbooks and other aids to learning in the science and technology of colour and coloration and related fields. The Society of Dyers and Colourists acts as trustee to the fund, its Textbooks Committee being the Trust's technical subcommittee.

Typeset by the Society of Dyers and Colourists and printed by The Alden Press, Oxford.

ISBN 0 901956 57 0

Contents

Contributors		viii
Prefaces		ix
CHAPTER 1	Traditional methods	
	by Leslie W C Miles	1
1.1	A historical perspective	1
1.2	Surface printing methods	8
1.3	Engraved-roller printing	11
CHAPTER 2	Screen printing	
	by Christopher J Hawkyard	18
2.1	Introduction	18
2.2	Hand screen and semi-automatic screen printing	20
2.3	Fully automatic flat-screen printing	24
2.4	Rotary-screen printing	31
2.5	Design aspects	37
2.6	Computer-aided design	40
2.7	Screen production	43
2.8	The fundamental mechanism of screen printing	53
2.9	Nontextile applications of screen printing	54
CHAPTER 3	Transfer printing	
	by Ian D Rattee	58
3.1	Introduction	58
3.2	Sublimation transfer	60
3.3	Melt and film release transfer	87
3.4	Wet transfer printing	95
CHAPTER 4	Carpet and yarn printing	
	by Timothy L Dawson	99
4.1	Historical development of carpet printing	99
4.2	Yarn printing (space dyeing)	102
4.3	Carpet printing	103
4.4	Printing of carpet tiles	114

- 4.5 Treatments before and after printing 115
- 4.6 Physical factors affecting the quality of printed carpets 118
- 4.7 Selection of dyes and chemicals for printing nylon carpets 126
- 4.8 Printing of carpets tufted from fibres other than nylon 135

CHAPTER 5 Direct print coloration
by Heinz Gutjahr and Robert R Koch 139

- 5.1 Introduction 139
- 5.2 Pigment printing 140
- 5.3 Cellulosic fibres 153
- 5.4 Polyester fibres 172
- 5.5 Cellulose acetate fibres 176
- 5.6 Acrylic fibres 178
- 5.7 Polyamide fibres 181
- 5.8 Protein fibres 183
- 5.9 Polyester/cellulose fibre blends 187

CHAPTER 6 Discharge, resist and special styles
by Clifford Berry and John G Ferguson 196

- 6.1 Introduction and definitions 196
- 6.2 Discharge printing 197
- 6.3 Application procedures in discharge printing 206
- 6.4 Resist printing 217
- 6.5 Special styles 230

CHAPTER 7 The production and properties of printing pastes
by Leslie W C Miles 240

- 7.1 The requirements 240
- 7.2 Thickeners 241
- 7.3 Raw materials: polysaccharides 245
- 7.4 Viscous emulsions 255
- 7.5 Viscous foams 257
- 7.6 Synthetic-polymer thickeners 257
- 7.7 Print paste rheology 260
- 7.8 Print paste production 272
- 7.9 Colour shop organisation 273

CHAPTER 8 **Fixation and aftertreatment processes**

by Leslie W C Miles

275

- 8.1 Introduction 275
- 8.2 Pigment prints 275
- 8.3 Steamers 276
- 8.4 Miscellaneous techniques 291
- 8.5 Washing-off processes 292
- 8.6 Washing-off equipment 296

Contributors

Clifford Berry

Formerly marketing manager (textile dyestuffs), Hoechst UK Ltd, Halifax, UK

Timothy L Dawson

Honorary research fellow, UMIST, Manchester UK

John G Ferguson

Textile dyestuffs manager, Hoechst UK Ltd, Halifax, UK

Heinz Gutjahr

Formerly chemist, Dyestuff Marketing, Bayer AG, Leverkusen, Germany

Christopher J Hawkyard

Lecturer in polymer and fibre science, UMIST, Manchester, UK

Robert R Koch

Head of Textile Printing Department, Bayer AG, Leverkusen, Germany

Leslie W C Miles

Formerly lecturer in textile chemistry, UMIST, Manchester, UK

Ian D Rattee

Research director, Wace Screen (a division of Wace UK Ltd), Wakefield, UK and former professor of colour chemistry, University of Leeds, Leeds, UK

From the preface to the First Edition

Textile printing is probably best described as an industrial art, having a long history and an assured future. It has become more dependent on the sciences than it was, but will always be a multidisciplinary activity, requiring more than a knowledge of science and technology.

The need for a textbook has been evident for some years, as the techniques, substrates and colorants in use have changed so dramatically since the admirable *Principles and practice of calico printing*, by Knecht and Fothergill, was last revised in 1952. The present work is intended to provide the information and understanding required by students preparing for the Associateship examinations of the Society of Dyers and Colourists. Many others, we hope, will also find it of value.

For those readers with practical, rather than academic, objectives, perhaps looking for answers to specific technical questions, a warning may be necessary. In a short book on such a substantial subject, some generalisations are inevitable but dangerous. Successful printing depends not only on using the appropriate materials and techniques, but also on the coordination of many individuals' skills. Printing machines have been compared to musical instruments, in that the results obtained depend on who is playing. In any printworks, the difficult patterns are given to the best printers, but even the best printer has to work within the limitations of his equipment and his supporting team.

Before describing current techniques, a brief discussion of the historical development of textile printing may be helpful. The English term 'printing' was coined in the 18th century and is derived from a Latin word meaning pressing, the word 'impression' being similarly derived. At that time printing was normally achieved by the use of wood blocks, with raised printing surfaces, which required pressure to obtain good contact between the fabric and the colour on the block.

Wood blocks were certainly used for printing illustrations in books at around 1400, and on linen hangings at about the same time. In China, they had been used in the 10th century. Stencil printing of playing cards was established in around 1440, and engraved-copper-plate printing was used in Venice in 1450. Techniques used on paper were naturally tried on fabrics, but often required long processes of trial and error before they could be successfully adapted.

Techniques of resist dyeing, mordant printing and painting had been developed in the East at a much earlier period. Herodotus wrote of the painting of garments in the 5th century BC, a dye that was probably indigo being used. In fact, it was the enormous demand for colourful hand-painted cotton fabrics, imported from India in the 17th century, that stimulated the inventiveness and drive of the

European pioneers. By 1842 some 90% of British prints were produced on machines, rather than by hand block and, at about that time, 60% of the cotton fabric produced was printed. The pioneer printers of Europe not only developed the machinery and mastered the art of using suitable thickeners, but were also innovators of the factory system.

LESLIE MILES

Preface to the Second Edition

The 1981 edition was widely welcomed and became a standard textbook. But it was clear that a second edition was required and we have taken the opportunity to effect some significant updating. The whole book has been updated and I hope that it will prove to be of lasting value, to students and the industry around the world.

The near demise of roller printing since 1981 prompted the replacement of the first chapter, which was a very thorough account of this technique, by one on the historical development and the traditional methods of printing. Screen printing is certainly the dominant method at the present time, but block printing and roller printing are still of some significance and of technical interest. I am pleased that we have included both this time. The other development that we have reflected is the substantial use of computer-aided design (CAD) and of computers in screen production in printing processes. The extension to jet printing, with its potential of very quick response, is not yet beyond the development stage – for flat fabrics – but may be important for a future editor.

My thanks are gratefully recorded to all the authors, especially Ian Rattee who has provided invaluable expertise on transfer printing (originally dealt with by the late Frank Jones). I wish to acknowledge the assistance of Paul Dinsdale (the Society's editor) and Carol Davies for her expert typesetting and layout. Jean Macqueen has improved the text significantly and provided the index, for which I am indebted. I am also grateful for all those individuals and organisations who granted permission to reproduce illustrations, as signified in the figure captions.

LESLIE MILES

CHAPTER 1

Traditional methods

Leslie W C Miles

1.1 A HISTORICAL PERSPECTIVE

Textile printing is the most versatile and important of the methods used for introducing colour and design to textile fabrics. Considered analytically it is a process of bringing together a design idea, one or more colorants, and a textile substrate (usually a fabric), using a technique for applying the colorants with some precision. Several techniques have been used and the colorants available have multiplied. This chapter presents an overview of the changes that have occurred, together with an examination of some techniques that have almost ceased to be of commercial importance, for their own intrinsic value and because we can learn from the lessons of the past.

The desire to create garments and other artefacts that reflect the beauty of the world around us and provide for the expression of our artistic nature has been evident from early in human history. The decoration of the body presumably predates the production of clothing. Early men and women used the colorants that were available to them, such as charcoal and coloured earths (ochres), mixed with oils and fats, applying them at first with their fingers and sticks to a variety of substrates. Staining of fabrics with plant extracts provided a different approach; patterns could be produced by applying beeswax as a resist to the dye liquor or by tying threads tightly around the areas to be resisted. The realisation that certain colourless materials could be used as mordants to fix some plant dyes was a vital step in the prehistory of dyeing and printing. The discovery that different mordants, applied first, gave different colours with the same dye (for example, from the madder root) must have seemed little short of magical and suggested a style of printing (the dyed style) that was to become of cardinal importance.

Where this style of printing originated – whether in India, Egypt, China or elsewhere – is not clear. Brunello states that an early variety of cotton dyed with madder around 3000 BC was found in jars in the Indus valley [1]. Taylor gives evidence



of madder on flax found in Egypt and dated at 1400 BC [2]. In China the dyeing of silk was developed very early, and China is credited with the invention of paper printing and therefore may well have seen the birth of fabric printing.

1.1.1 The use of block printing

The word ‘printing’ implies a process that uses pressure, being derived from a Latin word meaning pressing. The German word *druck* for print also means pressure. And there is no doubt that the first textile-printing technique (making impressions) was that using blocks with raised printing surfaces, which were inked and then pressed on to the fabric. By repetition, the image from a single block builds up into a complete design over the fabric area. Some early blocks were made of clay or terracotta, others of carved wood. Wooden blocks carrying design motifs were found in tombs near the ancient town of Panopolis in Upper Egypt. In the same area a child’s tomb contained a tunic made of fabric printed with a design of white rectangles, each enclosing floral motifs on a blue background. Pliny (born AD 23) described in his book *Historia naturalis* how in Egypt they applied colourless substances to a fabric that was later immersed in a dyebath that quickly produced several colours. As Pliny also records that the best-quality alum was obtained from Egypt, it seems likely that alum was one of the mordants used and that the dye was madder.

By the 14th century the use of wooden blocks for printing was certainly established in France, Italy and Germany, but the craft was practised by ‘painters’, using mineral pigments rather than dyes. One of the early European uses of blocks was to produce church hangings that imitated the more expensive brocades and tapestries. Cennini, writing in 1437, described in some detail the production and use of brick-sized wooden blocks to print a black outline on brightly coloured cloth, which was then hand-painted with other bright colours [1]. In 1460 the nuns of a convent in Nuremberg described the block printing of mineral colours in boiled resinous oils, of gold and silver leaf, and of wool ‘flock’ on to a printed adhesive. The later development of block printing is described in section 1.2.1.

In the 15th century Portuguese traders were discovering the potential for trade with India, where the dyed style was used to produce cotton fabrics of great beauty that were quickly in demand in Europe. As early as the first century AD there was an Indian centre famous for the production of painted fabric [3], and the use of madder was by then long established. Early in the 17th century hand-painted Indian cottons were reaching London in significant quantities. They were both colourful and colour-fast, and introduced a richness of novel and stimulating design styles. Paisley designs, for example, were derived directly from one of these styles and the words ‘calico’ and ‘chintz’ were adopted into the language at around this time. A substantial and lucrative



import trade began, reaching a peak about 1700. In 1708, Daniel Defoe wrote that ‘everything that used to be wool or silk was supplied by the Indian trade’.

The craftsmanship applied to produce these prints can be judged from the following summary of the process. The cloth was wetted with milk and burnished to achieve a smooth surface. The design was transferred from paper, using charcoal powder that was rubbed through holes pricked in the paper. The main outlines were painted in and the fabric was then waxed, except for the areas that were to be blue or green. The latter were dyed in a bath of reduced indigo, and the wax was then removed by scraping and washing. After drying, the reds, pinks, lilacs, browns and blacks were painted in with the appropriate metal acetate mordants, aged and developed in a madder extract dyebath. If necessary, the pale areas were rewaxed and darker colours obtained by a second dyeing. Thorough washing removed most of the unfixed dye, and then bleaching in the sun whitened the ground. Painting in a saffron yellow for green and yellow areas completed the work.

The desire to imitate these prints in order to compete in the new market was soon aroused. Merchants who had earlier organised the production of larger quantities by the Indians, and who had also encouraged them to speed up the process by using block printing, turned to the foundation of factories in Europe near the main ports of entry. In 1648 the first recorded calico-printing factory was set up in Marseille. In 1676 there were units in Amsterdam and London. Among the merchants who financed the trade was one of the best known Huguenot families, the Deneufvilles, and before the end of the century the Huguenots had established the new industry in Berlin, Bremen, Frankfurt, Neuchatel, Lausanne and Geneva [4].

The importance of printing in the commerce of Europe was very significant in the 18th century and the growth of the textile industry was clearly stimulated by the demand for prints. The British prohibition of printed cotton in 1721 actually helped because Lancashire-woven linen/cotton ‘fustians’, which used flax grown in the Fylde area, were exempt. The linen yarn provided a strong warp, and the developing industry moved from London to the Manchester region, and also to Northern Ireland and Scotland where flax was also grown. The factory system of spinning had not yet been developed; it was not until 1766 that Hargreaves invented the spinning jenny. Yet in 1729 there were already four Dutch printers employing more than 100 workers in each unit. In Britain the number of calico-printing firms grew from 28 in 1760 to 111 in 1785, with annual production rising to 12 million yards, and in 1792 it was estimated that at least 60% of the white cotton cloth produced was sent to the printers. After 1774, when Richard Arkwright achieved the repeal of the 1721 Prohibition Act, most of the growth was in the printing of 100% cotton fabric. Liverpool now became the centre for raw cotton import.



How had the European printers acquired the necessary skills? Making wooden blocks would not be too difficult but finding suitable thickeners may have taken time. Gum Senegal and tragacanth seem to have emerged as useful, and starch was added to improve the colour yield. A combination of block printing and painting (usually described as pencilling) was used for some time. The biggest problem was that of achieving bright and fast colours. Madder was the most important dye that was able to satisfy the need. It had been known, and used with a mordant, since Saxon times but not in prints or on cotton. Awareness of what the Indians had achieved was important, and information about their methods would be gleaned from merchants and from returned missionaries. As late as 1742 details of the method were being sought from a French Jesuit in Pondicherry by a friend in France. The importance of pretreating the cotton with milk fat may have been a vital piece of information, though olive oil became the preferred material in Europe. Attaining a bright red was a preoccupation for many years, and recipes became more and more complicated. The processes of ageing the print and clearing the last traces of madder from unprinted areas also presented new problems that were not solved immediately.

1.1.2 The use of engraved copper

The most significant innovation of the century, however, was the adoption of the intaglio technique, first in Dublin by Francis Nixon in 1752, then in London [5]. European artists had discovered the possibilities of reproducing pictures from an engraved metal plate in the 15th century. Copper could be incised by hand with a sharp steel tool, and was the preferred metal. Application of ink to the plate and cleaning the unengraved surface with a cloth preceded the careful laying on to the plate of a sheet of moistened paper which was then passed, on a board, through a press. This consisted of two rollers, with blankets providing some resilience and ensuring good contact with the ink. Nixon realised that this technique could be used in modified form for printing textile fabrics, thus providing a vital step in the movement towards a machine-based industry.

The Italian word *intaglio* had been applied to engraving of gemstones and metal. Wood engravings were obtained by printing from a surface left raised after cutting away negative areas, as for block printing on fabric. Intaglio prints produce much finer line and stipple effects. The effort required for hand engraving was soon reduced by application to the plate of a thin coating of blackened wax, which is easily scratched through to allow a controlled etching of the copper in an acid bath. Tonal effects are obtained by recoating with wax, except for the areas for dark tones, which are then etched to a greater depth. Artists who excelled in the use of this technique included Dürer, early in the 16th century, and later Rembrandt, Turner and Picasso.



The 'obvious' extension to prints on fabric had only occurred, before Nixon's time, in the production of maps on silk and similar applications where fast dyes were not required. Nixon took his technique to London in 1755, where there was already an established group of printers using block and wax-resist techniques, and by 1761 'an entirely new type of printed fabric decorated with figures, landscapes and architecture' confirmed the English pre-eminence in the field [5]. It was the delicacy of these prints, together with the boldness of large repeats, that made London the world fashion centre for a while. It was also a recovery of the fine but bold style of the best Indian prints but with a European signature. Schuele took the technique to Augsburg in 1766 and Oberkamp started using it in Jouy in 1770.

Copper plate printing did not displace block printing, because the skills required were greater and it was difficult to ensure that the design repeats fitted satisfactorily. The fabric was moved with the plate for each impression and the plate had then to be returned. The fabric tended to move out of line and its position and squareness had to be corrected by hand. The perfect answer to the fitting problem was to turn the copper plate into a cylinder, and this would allow truly continuous production at high speed. Even as early as 1699 it was claimed that an engraved (presumably wooden) cylinder had been used successfully [1], and patents were taken out in England in 1743 and 1764 for cylinder machines. It was 1783, however, before all the requirements for successful engraved copper roller printing were actually worked out and patented by Thomas Bell, a Scotsman. The first machine was in use in 1785 in Lancashire, and by 1840 there were 435 machines in England alone. The vital feature of Bell's machine was the use of a sharp steel 'doctor' blade to remove all the colour paste from the unengraved surface of the roller. The name given to the blade was derived from the word abductor, because it took away the unwanted ink.

Although considerable skill was required to engrave and use copper rollers, the increase in productivity resulting from their use was so great that block printing inevitably declined. Turnbull says that 'where by block it was only possible to print of the simplest pattern about six pieces per day, it was now possible to print by machine up to 500 pieces per day of a similar pattern' [6]. This was a revolution even more significant than those occurring in the spinning and weaving sectors, and there were inevitable disputes and strikes. But there could be no putting the clock back. Edmund Potter said in a lecture to the Society of Arts in 1852 that the output of printed calico in England increased from 1 million pieces (of 30 yards) in 1796 to 7 million in 1821, and to 20 million in 1851. By 1851 the number of machines had reached 604, while the number of blocking tables declined from 8234 in 1840 to 3939. By 1880 very few tables were still in use, except for the printing of silk and specialist styles. The rise of the roller machine reached a peak in 1911, when production from British printworks amounted to 1400 million yards, of which 90% was exported [7]. Worldwide, roller



machine production accounted for more than half of the total yardage printed until 1976, almost 200 years after Bell's 1783 patent.

While copper roller machines proved ideal for high-volume, low-cost printing of woven cotton fabrics, there was always a market for small-scale production of individual designs, especially on silk, wool and, later, on man-made fabrics. For these, roller printing was not suitable at all. The costs of engraving and setting up the machine for each run were high, and long runs were therefore essential. Block printing satisfied the demand for some time, but an alternative, fundamentally different approach emerged.

1.1.3 From stencils to rotary screens

The technique of stencil printing, initially used for simple patterns on walls and for lettering, was developed into an intricate craft for fabric printing in Japan [8]. In the 17th century the idea of tying together parts of the stencil with human hair initiated the development. Then in 1850 in Lyons the first use of a silk gauze as a supporting stencil base was employed, and the technique soon became known as screen printing (Chapter 2). This proved to be the answer to the requirements of the couture business, partly because the designers found it well suited to their needs, but also because strong, bright colours could be obtained with minimal restriction on repeat dimensions. The use of hand screen printing grew in the period 1930 to 1954 and was ideal for the growing quantities of man-made fibre fabrics, especially the knitted fabrics. With the successful mechanisation of flat-screen printing and ultimately the use of rotary-screen machines, the days of the copper roller machine were numbered. In 1990 the worldwide production from the latter was estimated to be only 16% of the total, while 59% was from rotary screens (Figure 1.1). In the UK the switch from copper roller printing was initially slow but then accelerated, the technique's share falling from 90% in 1960 to only 6.6% in 1992. In the same period the output from rotary-screen printing grew from perhaps 1% of the total to 82.8%. Thus the machine introduced in 1785 dominated the industry for some 160 years, but is now fast disappearing. The use of copper rollers is still important in the gravure method of printing in colour on paper (see section 3.2.2). The dimensional stability, uniform thickness and surface smoothness of paper makes it possible to achieve a much greater precision than is possible on textile fabrics. Even in the paper printing sector, however, cheaper methods have captured a significant fraction of what was the market for gravure machines. This is relevant to our consideration of textile printing in relation to transfer printing (Chapter 3), which provides a valuable approach to garment printing and for the printing of polyester fibre fabrics, and which currently holds about 6% of the total market.



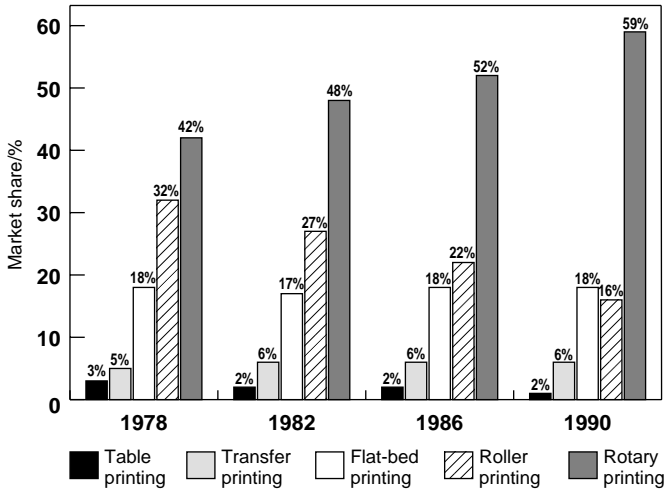

Figure 1.1 Relative contributions of printing methods to total world printed textile production (Stork BV)

1.1.4 Other methods

Apart from transfer printing, there are five essentially different approaches to the printing of any substrate. We have seen that three have achieved historical importance in the textile field – the surface (block), intaglio and screen methods – and that nowadays screen printing is the predominant approach. A fourth approach, lithography, has been used to a very small extent for printing smooth surface fabrics but is of more importance in paper printing, including transfer paper.

The fifth approach, jet printing, is a 20th century method of building up a design from ink drops. It is already important for printing pile fabrics (Chapter 4) and paper, and could become a serious competitor to screen printing. It is the only approach that can provide the really rapid response to changing demand that is increasingly expected, because there is no requirement for the production or changing of patterned screens or rollers; in addition, instantaneous use for sampling or long runs is potentially available. The significant development in these last decades of the century has been the success of computer technology, so that computer-aided design (CAD) systems and colour match prediction are in regular use. The scanning of an original design can now provide the data required for its reproduction by any technique, but fits into the jet printing route more directly because the jets require only electrical control. It remains to be seen, however, if the development of jet systems that are practical and economic for a wide range of fabrics can be achieved. The first commercial production unit, based on Canon bubble-jet technology, is being built in Japan [9].



1.1.5 Colorants

The earliest colorants used in printing were undoubtedly mineral pigments, although the dyed style was also in early use. Today the availability of a wide range of excellent organic pigments and of reliable pigment binders (section 5.2.2) has led to the increased importance of pigment printing. More than 50% of the world's textile prints were pigment-printed in 1990. The substantial importance of polyester/cellulosic blends has increased their use, because of the complexity of printing these substrates with dyes.

It has proved possible to reduce, though not to eliminate, the extra costs (and risks) attached to the general use of dyes, due to their requirement of steam fixation and after-washing. In 1984, Schofield recorded the impact of changes in dyes over a 50 year period [7]. Reactive dyes now account for 25% of print colorants, disperse dyes 10%, vat dyes 9% and azoics 3%. In all dye ranges a high priority has been given to selection for 'robustness', or the ability of a dye to give reproducible results due to low sensitivity to likely variations in conditions. The tasks facing colourists in the early years of the century were far harder than those of their successors today but their achievements, as judged by prints to be seen in the museums, were highly creditable.

The development of printing techniques from the earliest days has been reviewed. In the following chapters those techniques now in substantial use are considered in detail. Here we must examine the surface and intaglio techniques in sufficient detail for an appreciation of their past and present value.

1.2 SURFACE PRINTING METHODS

1.2.1 Block making

The typical hand block print had no large, uniform areas of colour but was skilfully built up from many small coloured areas, because wooden surfaces larger than about 10 mm in width would not give an even print. This had the advantage that a motif such as a flower would have an effect of light and shade obtained from three or four blocks, each printing a different depth of the same colour, or a different hue. This obviously meant that a lot of blocks were required, and considerable care was needed in fitting the adjacent parts of the design. If the design had a large repeat there would be a multiplication of the number of blocks because the size of a single block was limited to about 45 cm square and its weight to about 5 kg. Most blocks were much smaller than this, perhaps because many printers were women.

Block making required patience and skill. A fairly hard wood was required, such as pearwood, and four or five layers were usually glued together with the grain running in different directions. The design was traced on to the surface and a fine chisel used to



cut away the nonprinting areas to a depth of perhaps 1 cm. To obtain more detail from some blocks, strips and pins of copper or (more usually) brass were hammered into the wood. In the 19th century some blocks were made with the printing surface entirely in brass (Figure 1.2), which gave very delicate prints. Another technique used for complex designs was to prepare a mould, use this to cast the image from molten type metal, fasten the casting to the block, and then grind the surface perfectly flat. When large areas of solid colour were required, the areas within metal or wooden outlines were filled with felt, which would absorb and print the paste uniformly. Finally, each block required corner 'pitch pins' which printed small dots; these allowed the succeeding blocks to be correctly positioned by accurately locating the pitch pins above the already printed dots.

A less precise form of block printing is practised in the production of, for example, Africa prints (see section 6.5.1), using large plywood blocks with polyurethane foam printing surfaces.

1.2.2 The printing table

A very solid table was needed; it was topped with flat slabs of stone or iron covered with a resilient blanket and a sheet of waterproof material. A back-grey of plain cotton was usually stretched over the table, to absorb any surplus colour. Ideally the back-grey would be gummed to the table and the fabric to be printed could be pinned to it, for tight-fitting patterns.

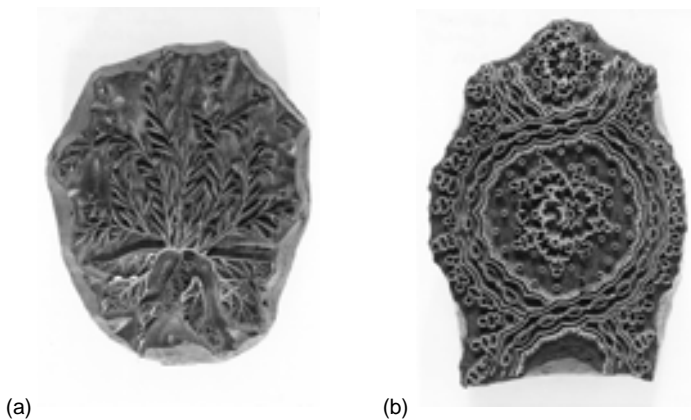

Figure 1.2 Wood blocks with (a) brass strip and pin inserts, (b) a cast type-metal printing surface (without pitch pins)

1.2.3 The printing process

Colour paste must be applied to the block surface in a controlled manner, and this was achieved by using a 'sieve'. A small tub was nearly filled with a starch paste and a waterproof fabric, stretched on a frame, rested on the paste. A piece of woollen fabric was stretched on a slightly smaller frame and fastened to make the sieve. The sieve was saturated with colour paste and placed on the waterproof fabric. For each impression, the 'tierer' (a boy) spread the colour paste on the top surface of the woollen sieve with a large brush and the printer charged the block by pressing it on the wool. The block was then carefully positioned on the fabric, using the pitch pins as guides, and struck with a mallet. After printing a table length with the first block, the second was printed and then any others required to complete the design. The fabric was then transferred to a few elevated rollers or rods and allowed to dry, while the next table length was printed.

1.2.4 Mechanisation

In 1834 a machine that automatically performed all the actions of block printing was invented by Perrot (it became known as the Perrotine), and achieved some success. It was limited to three colours and a maximum repeat of only 15 cm and its operation could not be truly continuous, but the three colours were printed simultaneously. Storey gives an illustrated account of this machine, and of hand block printing [3].

Much earlier, attempts had been made to obtain continuous surface printing using wooden rollers, but the difficulty of uniform application of the colour to the roller was the common problem. In about 1805, however, a rotating woollen fabric 'sieve' was introduced in Accrington, and used successfully thereafter (Figure 1.3) [6]. The other essential step was the preparation of a raised pattern on the roller by inserting copper outline strips and felt, just as in hand block printing. This technique was used until recently for printing furnishing fabrics and for wallpaper, but was never as important as the copper roller method. It had the advantages of requiring low pressure and avoiding the colour contamination that occurs on engraved roller machines, because no contact was made with previously printed colour, but the cost of roller making was high. Wallpaper printers found that inexpensive rollers could be cast from epoxy polymers and the nonprinting areas were easily cut away, but they did not carry enough colour to print most fabrics.

Essentially the same method has been used for printing polymer film, other packaging materials and transfer paper, but is then usually known as flexographic printing. As described in section 3.2.2, the design is built up on wooden rollers by the application of rubber mouldings and the colour is applied by uniformly engraved metering rollers.



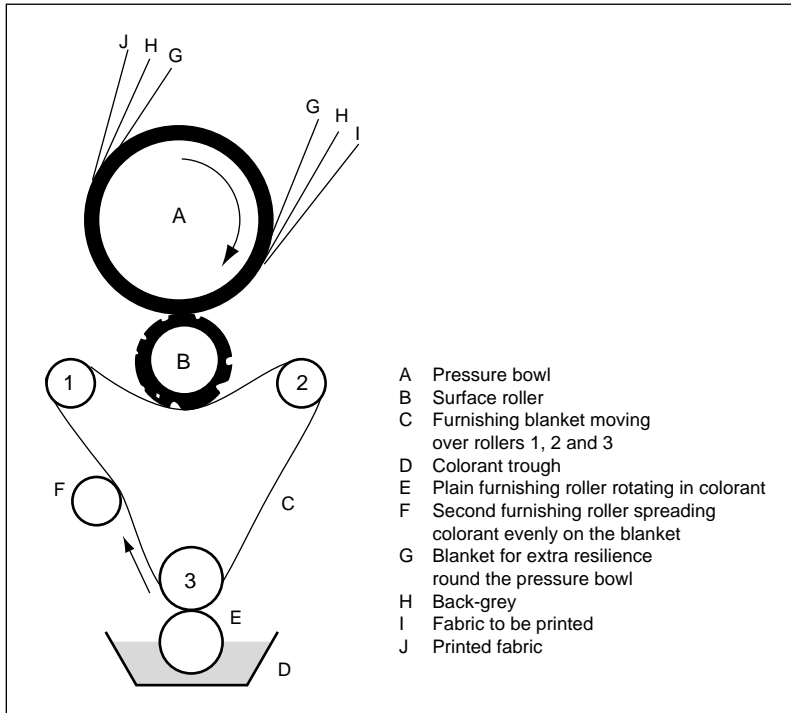

Figure 1.3 Surface printing machine with woollen fabric sieve

1.3 ENGRAVED-ROLLER PRINTING

1.3.1 Principles of operation

A traditional two-colour machine is shown diagrammatically in Figure 1.4. Each engraved cylinder (F), mounted on a steel mandrel (L), is forced against the fabric being printed (E) as it travels around a pressure bowl (A) with resilient covering (B). The machine must be of robust construction because pressures of several tonnes are applied and each mandrel is driven by a single large crown wheel. As the rollers rotate, a furnishing roller (G) transfers print paste (colour) from a colour box (H) to the engraved cylinder, filling the engraving and smearing the whole surface. This surface colour is almost immediately removed by the steel blade known as the colour doctor (J). This doctor must be precisely ground, sharpened and set, at the optimum angle and tension, to leave the surface perfectly clean. Engraved areas retain the colour in parallel grooves and the doctor blade is 'carried' on the crests between the grooves.

The fabric is then forced into the engraving and most of the paste is transferred. The cushion between the pressure bowl and the engraved roller clearly plays a critical



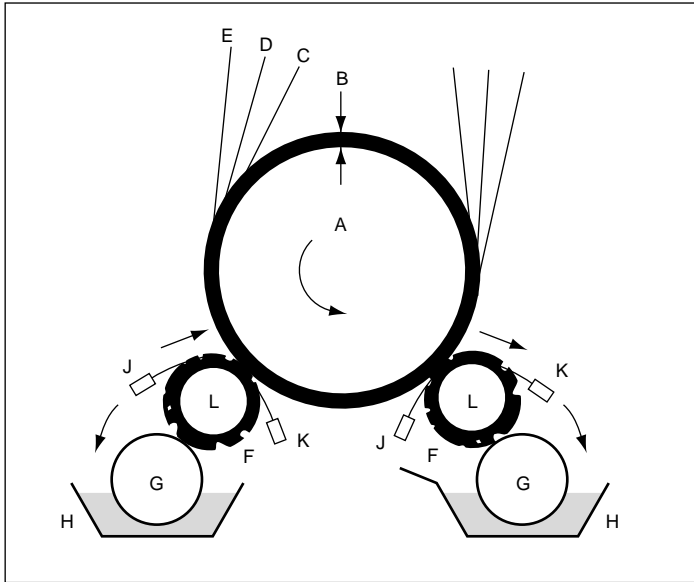

Figure 1.4 Two-colour printing machine (for key see text)

role in the uniform transfer of colour across the fabric width and along its length. The cushion is obtained by rolling about ten layers of a lapping fabric with linen warp and woollen weft around the pressure bowl. Any irregularity, including any ridge at the end of the lapping that may develop if it is not perfectly matched with the first end, can cause a visible fault in a critical print. The cushion progressively hardens with use and requires changing from time to time. Because the lapping must be protected from colour printed beyond the fabric edges or forced through the fabric, an endless printing blanket (C) must be used and washed and dried continuously before returning to the point of printing. In addition, a back-grey (D) is used to absorb colour and give greater resilience, unless the blanket provides enough resilience and is able to hold the excess colour satisfactorily (for example, in fine grooves in a neoprene surface). In the printing of lightweight or knitted fabrics the woven back-grey is often 'combined' with the fabric to be printed, using small amounts of a suitable adhesive (see section 2.2). This helps to maintain dimensional stability under the tension applied during printing.

After transferring its colour, the engraved roller is cleaned by a brass blade known as the lint doctor (K). This removes any loose fibres that may have stuck to the surface of the roller and could become trapped under the colour doctor, where they could cause a colour streak to be printed. The lint doctor on the second (and any subsequent) roller may be seen to remove a significant amount of the previously printed colour that the roller takes up from the fabric. Without the lint doctor, this colour would be carried

into colour number two and cause rapid contamination, although some contamination is unavoidable because the lint doctor will push a little colour into the empty engraving.

The printed fabric is now separated from the back-grey and blanket and carried on to the drying section of the machine (Figure 1.5), avoiding any contact of the print face until some drying has been achieved. In the UK drying cylinders were often used in the past, but hot-air dryers are more universally appropriate.

On a multicolour machine the printing rollers, with colour boxes and other auxiliary equipment, are arranged around a larger pressure bowl with minimum separation of the rollers. Setting and maintaining the correct registration (that is, fitting each colour of the design relative to the others) requires an arrangement for separately rotating each roller a small distance while the drive to all the rollers is engaged. The original box-wheel device was elegantly simple but introduced a serious hazard to the printer's hands as it required the insertion of a rod, or tommy key, into a hole in a wheel rotating near the meshing drive gears. A safer device has been described by Gleadow [10], who has also given a more detailed account of engraved-roller printing.

It is necessary to correct the pattern fit from time to time during printing, because each roller will have a different effective circumference if there are significant differences in the area engraved or the pressure applied. Thus the fabric will be stretched or allowed to relax to a minute degree between rollers and the fit of the design will gradually be lost. As already noted, combining with a back-grey can improve stability.

Good pattern fitting also requires a perfectly rigid fit of the engraved cylinder on its mandrel. To this end, the cylinders and mandrels are tapered and a forcing jack is

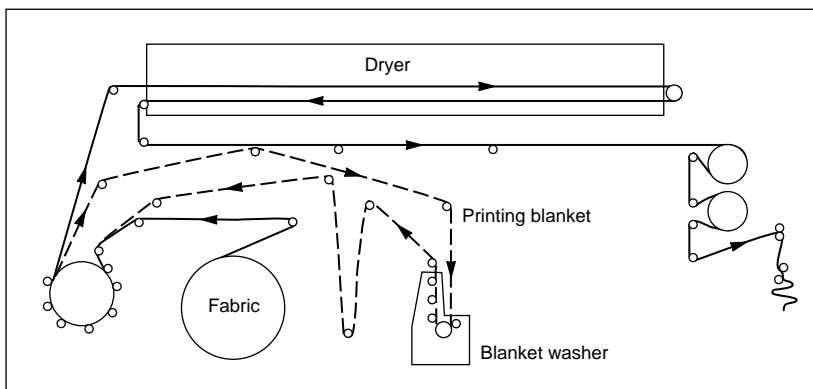

Figure 1.5 Overall arrangement of a six-colour machine with hot-air drying, showing blanket washer

required to mount and to remove the mandrel. In addition a key, or 'tab', on the inside of the cylinder engages in a slot along the mandrel.

1.3.2 Problems

A major disadvantage of engraved-roller printing that has shown up in recent years is that there is a limit to the fabric width that can be printed. The application of pressure to the mandrel ends inevitably produces some bending and the fabric edges tend to be printed more heavily than the middle. The printer makes some allowance for this by applying additional lapping to the centre of the pressure bowl, and the use of minimum pressure obviously helps; even so, it is not usually possible to print fabrics more than 1.8 m wide by this technique. Wider fabrics, essential in the home-furnishing market and showing cost advantage in most fabric areas, are therefore normally screen-printed.

Another disadvantage of engraved-roller printing is that the sequence of colours printed cannot be chosen arbitrarily, because of the colour contamination problem mentioned earlier. The pale colours should be placed early in the order, with the stronger ones at the end. Sometimes it is necessary to start by printing a dark colour (for instance, a black outline) to obtain the required depth when one colour falls on another. In such a case a plain roller may be inserted after the dark one, and a colourless paste used with it to reduce the contamination of the next colour. The effect of successive rollers, which take off some of the printed colour and push some further into the fabric, is described as the 'crush effect' and can reduce the visible colour strength by up to 50%. This is clearly another major disadvantage, compared with block and screen printing.

A third significant disadvantage is the time lost in pattern changing, due to the need to handle the heavy rollers and associated accessories and to difficult access. Effective printing time is often less than 50% of working time, and really short runs reduce this dramatically. Roller weight was reduced by using cast-iron cylinders with an electrodeposited copper plating, and damage to roller surfaces reduced by chromium plating. A redesign of the machine introduced by Brückner in Germany (Figure 1.6) provided improved access and, by increasing the contact time between roller and fabric, allowed a reduction in loading pressure and the use of shallower engravings. New thinking like this would probably have been accepted but for the rapid development of rotary-screen printing; the competition from the newer technique has decimated this section of the industry.

1.3.3 Roller engraving

Printing, originally a hand craft, developed into an industrial art requiring the



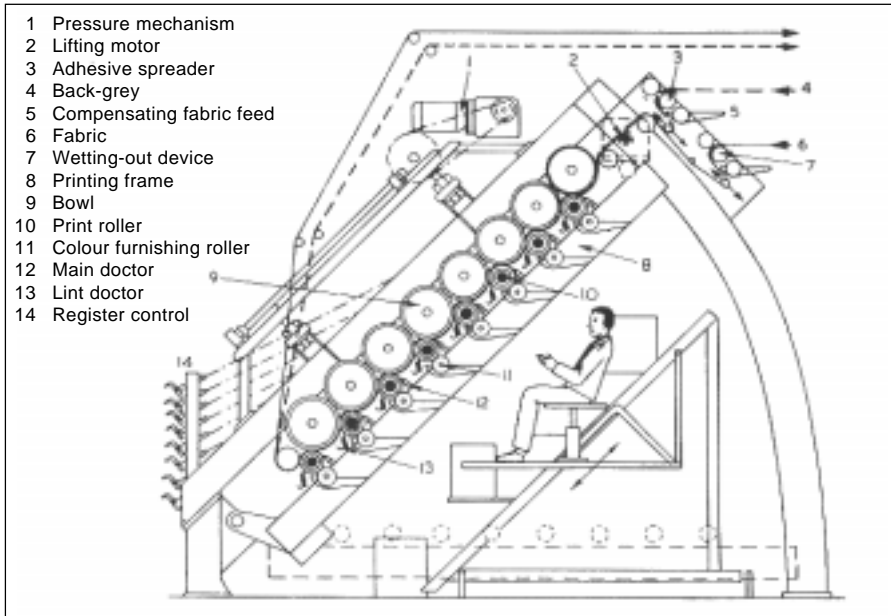

Figure 1.6 Roller-printing machine (Brückner)

contributions of a range of specialists, coordinated by someone with a clear vision of the desired end-product. The first of the specialists is the creator of the original design, which may already be suitable for reproduction but usually is not, and is sometimes little more than an idea. Another specialist is the engraver whose task is to convert the original design into a set of engraved rollers that will enable a printer to achieve an effective reproduction of the design on fabric. Sensitivity to the original design objectives and awareness of the printer's requirements are important as well as skill and accuracy.

An original design must be put into repeat (Chapter 2) and the dimensions adjusted so that one or more repeats will fit accurately around the roller circumference. If the repeat is small it may be that the mill-engraving method should be used. This starts with the hand engraving of a few repeats on a small soft-steel cylinder, which is then hardened. The design is then obtained in relief by running the first cylinder (the die) under pressure in contact with a second soft-steel roller. This relief roller (the mill) is hardened and run in contact with the copper cylinder to obtain the desired depth of impression, and this is repeated across the cylinder until the full width is engraved. The raised copper around each groove must then be polished off.

Photoengraving, a more widely applicable method, uses a chemical etching technique to remove copper from the areas that will hold colour. Each roller, which (as



in all methods) has previously been turned to size, polished and cleaned, is given an even coating with a photosensitive polymer solution (using a safe light). The essential steps in the process are then as follows.

1. A master copy of the design is drawn, in outline, and a copy made for each colour. Colour separations are made by blocking out with opaque paint all the areas except those of one colour, repeating the process for each colour in the design. At the same time, adjustments must be made for any overlap of colours required or allowance for colour spread. These separations can now be made by electronic colour scanners with appropriate computer software.
2. The negative colour separations are converted into positive images (diapositives) on stable photographic film, and at the same time the ground lines are introduced by exposing through a grid of lines of the required spacing (Figure 1.7). At the same time an outline around the solid areas must be obtained, by using suitable spacers.
3. A step-and-repeat machine (section 2.5.4) is used to produce a full-size positive film for each colour that will cover the complete roller surface.
4. The complete set of films is assembled and checked by transmitted light to ensure perfect register.

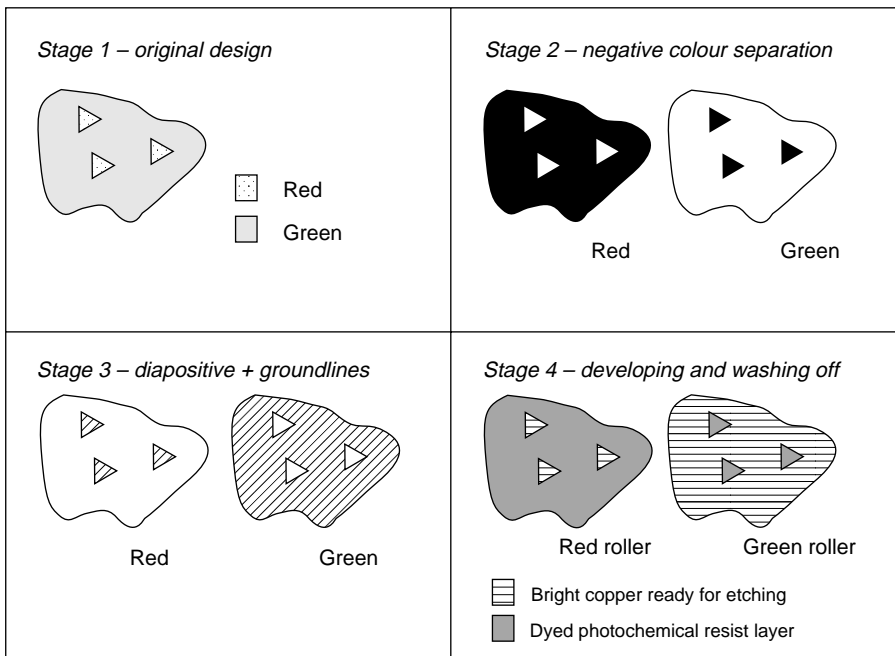

Figure 1.7 Schematic representation of the main steps in the photoengraving process

5. Each film is accurately positioned and fixed and the image is transferred while the roller rotates under a suitable light. Within those areas that are exposed to light the polymer coating is altered chemically and becomes insoluble and acid-resistant. Unchanged polymer is washed off the unexposed areas.
6. Etching is carried out in a bath of acid or iron(III) chloride solution, until it is clear that the adjacent V-shaped grooves have almost met each other (small pieces of polymer float off at this point). The number of grooves per inch, the scale, corresponds to the grid spacing and determines the depth of engraving obtained and the amount of print paste held. A scale of 55 gives a depth of about 0.11 mm (0.005 in) and may be suitable for a smooth-surfaced synthetic fibre fabric, whereas a scale of 35 gives a depth of 0.20 mm (0.008 in) and would be more suitable for a cotton fabric.

Engraving for photogravure paper printing follows similar lines except that, instead of producing grooves to carry the colour, the engraver produces small hollows of controlled depth and spacing.

REFERENCES

1. F Brunello, *The art of dyeing* (Vicenza: Neri Pozza) American Edn 67.
2. G W Taylor, *Rev. Prog. Coloration*, **16** (1986) 53.
3. J Storey, *Manual of textile printing* (London: Thames and Hudson, 1992) 22.
4. S D Chapman and S Chassagne, *European textile printers in the eighteenth century* (London: Heinemann, 1981) 6.
5. P C Floud, *J.S.D.C.*, **76** (1960) 275, 344, 425
6. G Turnbull, *A history of calico printing in Great Britain* (Altrincham: Sherratt, 1951) 69.
7. J S Schofield, *Rev. Prog. Coloration*, **14** (1984) 69.
8. J Storey, *Textile printing* (London: Thames and Hudson, 1992) 111.
9. *Dyer*, **178** (Apr 1993) 8.
10. R W F Gleadow in *Textile printing*, 1st Edn, Ed. L W C Miles (Bradford: Dyers' Company Publications Trust, 1981) 13.



CHAPTER 2

Screen printing

Christopher J Hawkyard

2.1 INTRODUCTION

Screen printing is an extension of stencilling. Innumerable children experiment with simple stencils by cutting out shapes from card, and brushing or spraying paint or ink through the holes on to paper beneath. Commercial stencil sets for lettering are made of waxed card or metal, and incorporate ties to hold the solid areas together and to prevent the centres of letters such as O or P from falling out. The ties produce unsightly lines across the stencilled letters.

Centuries ago, when the Japanese developed the stencilling technique for textile printing and brought it to a fine art [1], they overcame this difficulty by using human hair or silk threads as ties. These were so fine that the colour spread underneath them, disguising their presence. By the 19th century, the use of this method for printing fabric had spread far beyond Japan and was used worldwide.

In the mid-19th century, French printers introduced the use of a woven silk fabric to provide a continuous support for the paper stencil. For the best results the support fabric was stretched across a frame, and the combination became known as a screen. The development was important because in this way not only were ties automatically provided, but the amount of colour paste applied could also be controlled. Soon after, the paper stencil was replaced by a durable paint on the screen fabric.

From this time onwards the advantages of screen printing became increasingly appreciated, especially in fashion houses. Designs are relatively easy to transfer to screens and the frame size can be readily varied. The designer, freed from the restrictions of copper rollers, thus had far greater freedom to choose repeat sizes. In addition, the pressure applied in screen printing is much lower than in roller printing with the result that surface prints with an improved 'bloom' or colour strength are obtained, and textured surfaces are not crushed.

The development of screen printing to its modern, highly productive form ran parallel with improvements in the screens themselves. Accurate printing of



multicoloured designs requires stable screens. Screen fabrics made from hydrophilic yarns, such as silk, cotton, viscose rayon or cellulose diacetate, are apt to sag when in contact with water-based print pastes. The introduction of hydrophobic synthetic fibres such as nylon and polyester, especially the latter, made it possible to manufacture stable screens that maintained tension when wet. Their high tensile strength also allowed the fabric to be stretched more tightly over the screen frame, thus improving the accuracy that could be attained. Further improvement came with the introduction of metal screen frames to replace the wooden ones used hitherto, which tended to warp when subjected to a regime of continually alternating wetting and drying.

Strong, stable screens enabled the hand screen-printing process to be mechanised. The first development was the introduction of a movable carriage, in which the screens are mounted one at a time. The squeegee (a flexible rubber blade used to spread the printing paste across the screen and force it through the open areas) was driven across the screen by a motor attached to the carriage. In this method, which is still in use, the fabric being printed is stuck down on long tables and one colour is printed at a time, just as in hand-screen printing.

The 1950s saw the advent of fully automatic, flat-screen printing, the Buser, Stork and Johannes Zimmer machines being prominent. These machines print all the colours in a design simultaneously along the top of an endless conveyor belt (blanket). The blanket and fabric are stationary while the printing operation takes place and then move on when the screens are raised; hence the fabric movement is intermittent.

Fully continuous printing is best achieved using cylindrical (rotary) screens and many attempts were made to form flat wire mesh screens into cylinders, despite the necessity of a soldered seam. When printing through a cylindrical screen with a seam, a line will show across the fabric once every cylinder circumference, unless the seam can be hidden within the design. This was the approach used in the screens manufactured by A J C de O Barros for the Aljaba machine, first introduced in 1954. Barros has written an interesting description of the Aljaba screens and machines [2].

Wire-mesh screens are too open for printing purposes, and on the early Aljaba screens electrodeposited copper partially filled the holes. This process was later discarded, to be replaced by the use of an outer seamless woven nylon sleeve. Later still, in fact after the closure of the Aljaba company, W Sword introduced a new version of the wire-mesh screen, the Durascreen [3], in which the holes in the mesh were partially filled with a flexible polymer by electrophoretic coating. The same process can also be used on electroformed nickel screens (see section 2.7.3), extending their life considerably, since the flexible polymer coating reduces the risk of creasing.

An important innovation of the Aljaba company was the duplex machine used by some printers to print both faces of curtain fabrics. The fabric ran vertically upwards between pairs of screens, print paste being forced through the screens by metal roller squeegees.



The invention of seamless screens of electrodeposited nickel was the really significant step which heralded the rapid expansion of rotary-screen printing. Peter Zimmer (Austria) introduced the galvano screen in 1961, and Stork (Holland) the lacquer screen in 1963. These screens soon proved to be superior, in many respects, to Aljaba screens. When Stork introduced their machine, based on the lacquer screen, at the 1963 ITMA Textile Machinery Show at Hannover it was an immediate success, so much so that Stork decided to stop manufacturing fully automatic flat-screen machines. Between 1964 and the end of 1972 Stork sold 600 rotary machines throughout the world.

Machines using rod or roller squeegees, such as those manufactured by Peter Zimmer and Mitter, have been very successful in printing wider substrates, such as carpets (see section 4.3.3). Rotary-screen machines have also been used to print paper for the transfer printing process (section 3.2.2). Currently rotary-screen printing is the predominant printing method worldwide, having substantially replaced copper-roller (intaglio) printing (Figure 1.1).

2.2 HAND SCREEN AND SEMI-AUTOMATIC SCREEN PRINTING

The practice of hand screen printing is now mainly restricted in the UK to colleges of art, small-scale units and the high fashion industry, as it is a craft rather than a productive method of printing. Printing is carried out on a flat, solid table covered with a layer of resilient felt and a washable blanket (usually coated with neoprene rubber). Heat for drying the printed fabric may be provided either under the blanket or by hot air fans above the table.

Fabric movement or shrinkage must be avoided during printing in order to maintain registration of the pattern. The fabric to be printed is laid on the table and stuck to the blanket directly, using either a water-soluble adhesive or a semi-permanent adhesive; alternatively it is 'combined' with a back-grey. In the latter instance an absorbent fabric is stuck to the blanket and the fabric to be printed is pinned down on top of it. Sometimes fabric and back-grey are combined before fixing to the table using an adhesive and a specially adapted pad mangle. Combining is most suitable for printing lightweight fabrics, where there is a danger of smudging or loss of adhesion caused by the presence of excessive print paste. It can also be advantageous for knitted fabrics.

Before a design can be printed, it must be reproduced on the screens in a suitable form. One screen is required for every colour in the design, except when the fabric is dyed to the background colour (known as the ground) before or after printing, or when a third colour is produced by one colour falling on another. When the background colour is printed it is termed the 'blotch'. The steps necessary to take an artist's original design to the stage of being ready for screen printing are detailed (section 2.5).



The printing process consists of forcing a viscous print paste through the open areas of the screen with a flexible, synthetic rubber squeegee. The rubber blade, which is contained in a wooden or metal support, is drawn steadily across the screen at a constant angle and pressure. If the screen is too wide to allow one operator to reach all the way across it, two operators may work together, one on either side of the table. The pressures exerted by the two must be as similar as possible.

The amount of print paste passing through the screen can be controlled in several ways. Factors affecting this are:

- the ‘mesh’ (threads per inch) or ‘raster’ (threads per cm) of the screen fabric; generally a coarse mesh allows more paste to pass through than a fine one
- the fraction of open area in the screen fabric; this depends not only on the mesh but also on the yarn diameter and the effect of subsequent treatments, such as calendering
- the hardness and cross-section of the squeegee blade; a hard rubber squeegee with a sharp cross-section is suitable for outlines, whereas a soft, rounded blade applies more paste and is suitable for blotches
- the hardness of the printing table; if the top of the table is firm a soft squeegee is probably necessary, whereas with a resilient table surface a harder squeegee is preferable
- the viscosity of the print paste; within the constraint of the requirement for good definition, the viscosity can be varied, thinner pastes passing through the screen pores more readily than viscous ones
- the number of squeegee strokes; from two to four strokes are usually applied
- the squeegee angle and pressure
- the speed of the squeegee stroke (see section 2.8.1).

All these variables should be taken into consideration, in conjunction with the nature of the design, when printing the chosen fabric.

Before printing begins, the screens must be carefully positioned on the fabric. The area printed by a screen (screen repeat) must fit exactly alongside the adjacent one, a slight overlap being preferable to a gap. With flat-screen printing this is not automatically achieved (as is the case with rotary printing). The differently coloured areas must be in register and, again, a small overlap is usually allowed. To achieve accurate registration it is common practice to attach to the frame a bracket which locates against fittings, known as ‘stops’, on a guide rail along one edge of the table. The stops are spaced exactly one (lengthways) screen repeat apart along the whole length of the table. Two adjustable screws set the distance of the frame from the rail (Figure 2.1).



As a further aid, repeat crosses known as 'pitch marks' may be incorporated at one or both sides of the screen and the positions of the following screens checked against the first pitch mark. Often registration marks are printed along the selvedge. One such scheme is illustrated in Figure 2.2.

When screen printing is carried out by hand, alternate repeats are normally printed along the full length of the table and then the gaps are filled in. This allows time for the print paste to penetrate the fabric and partially dry before the frame falls on the next printed area. If the design includes an outline this is printed first, to achieve maximum sharpness and as an aid to accurate fitting. The screen is then washed and the second screen introduced to print the second colour. The blotch screen, if there is

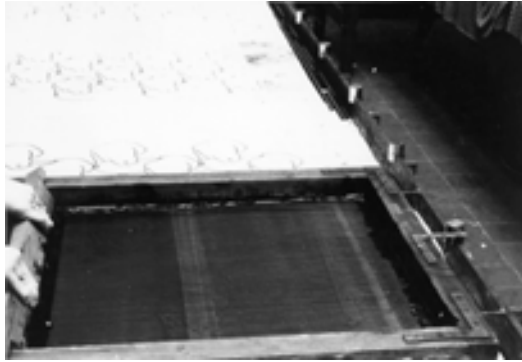

Figure 2.1 Hand screen printing showing stops, rail and bracket



Figure 2.2 Pitch marks: the first screen prints all the circles and a cross in the first circle, the second screen prints colour in the second circle and a cross in the first circle, the third screen prints colour in the third circle and a cross in the first circle

one, is usually left until last as the larger amount of colour is more likely to cause loss of adhesion between fabric and table, with subsequent loss of registration.

The manual process has been semi-automated by mounting the screen in a carriage and driving the squeegee mechanically across the screen (Figure 2.3). Long tables, typically 20–60 m long, are used, and some provision is usually made for drying the printed fabric. Semi-automated flat-screen printing is still very popular where the scale of production is not large, or where capital investment is limited. In both hand and semi-automatic flat-screen printing the colours are printed one after another with time for drying, which means that the situation approaches ‘wet-on-dry’ printing. Hence sharper results, especially for fall-ons (see section 2.5.3), can be achieved than is possible by printing all the colours in more rapid succession (‘wet-on-wet’).

Perhaps surprisingly, the level of automation for one-colour-at-a-time flat-screen printing has advanced a great deal recently. Instead of a flat, stationary table, a moving blanket is incorporated, as in fully automatic machines (discussed in section 2.3). The fabric is printed with the first screen, and passes round the end of the table and beneath it before being printed with the second screen, which can be positioned at a second station while the first colour is being printed. Clearly a good adhesive is required to prevent the fabric from becoming detached on its upside-down return journey.

Even more sophisticated developments have been introduced. The Italian company Viero have robotised the process completely. The operative at the console controls the robot, which lifts the screen from its rack (Figure 2.4), positions it accurately in the carriage, fits the squeegee, and then proceeds to collect the bucket of print paste, which it places on a shelf above the screen. It then tips the bucket to pour in the paste. Needless to say, the rest of the process is also automated.

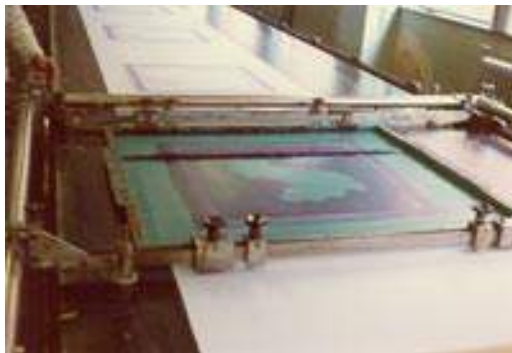

Figure 2.3 Semi-automatic flat-screen printing; in this machine the rod squeegee is rolled across the screen by means of a moving electromagnet under the blanket (Zimmer)



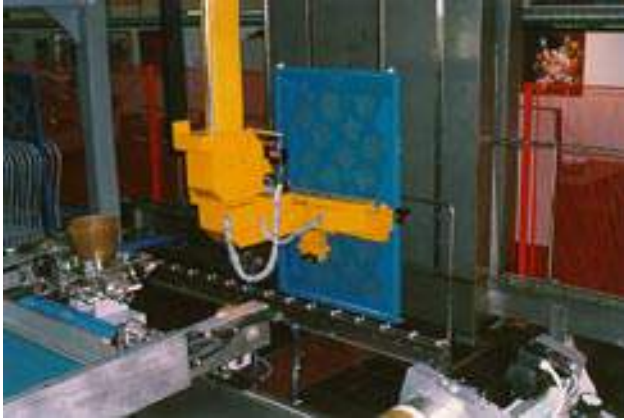

Figure 2.4 Robot lifting a flat screen from the rack prior to fitting it on the printing machine (Viero)

2.3 FULLY AUTOMATIC FLAT-SCREEN PRINTING

In order to increase the speed of flat-screen printing, it was necessary to devise a method of printing all the colours simultaneously. Unfortunately, flat screens are not suitable coloration units for a truly continuous process, and in all the successful machines for fully automatic flat-screen printing the colour is applied through the screens while the fabric is stationary.

The main features of a typical automatic flat-screen machine are illustrated in Figure 2.5 and shown diagrammatically in Figure 2.6. All the screens for the design (one screen for each colour) are positioned accurately along the top of a long endless belt, known as a blanket. A machine intended to print traditional furnishing designs might have space for 15 or more screens. The width of the gap between the areas printed by any two adjacent screens must be a whole number of lengthways design repeats. This need not necessarily be the same as the lengthways screen repeat as there may be several design repeats per screen repeat; for example, where there are three design repeats per screen repeat, the gap between adjacent screens need only be one-third of a screen repeat.

The fabric is gummed to the blanket at the entry end and moves along with the blanket in an intermittent fashion, one screen-repeat distance at a time. All the colours in the design are printed simultaneously while the fabric is stationary; then the screens are lifted and the fabric and blanket move on. When the fabric approaches the turning point of the blanket, it is pulled off and passes into a dryer. The soiled blanket is washed and dried during its return passage on the underside of the machine.





Figure 2.5 Fully automatic flat-screen printing machine (Buser)

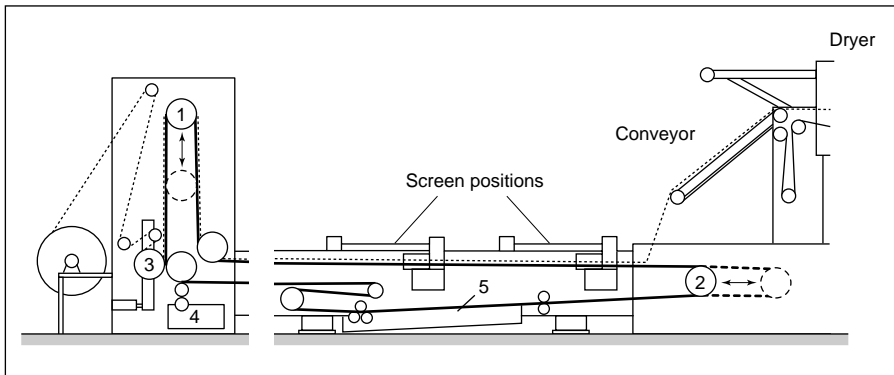

Figure 2.6 Fully automatic flat-screen printing machine (simplified diagram); rollers 1 and 2 move as shown, to maintain the lower side of the blanket in constant motion, 3 is the pressure roller, 4 the temporary adhesive application unit and 5 the blanket washer (Buser)

2.3.1 Adhesive systems

When fully automatic flat-screen machines were first introduced, it was quite common to combine the fabric to be printed with a back-grey, especially if the fabric was lightweight (section 2.2). As adhesives and methods of their application were improved, this practice became less important. The method which then became established, and which is still in use in many plants, is to apply a water-based adhesive to the blanket at the entry end, by means of a brush running in a trough containing the adhesive solution, and to spread the layer more evenly with a rubber squeegee; the



fabric is then pressed against the tacky blanket with a pressure roller. A hot-air dryer is sometimes employed to dry the adhesive before the fabric is printed.

The alternative to the continuous application and removal of aqueous adhesive is the use of a tacky semi-permanent or 'permanent' adhesive on the blanket. Such adhesives, often based on acrylic copolymers, can withstand the washing necessary to remove excess print paste without becoming detached from the blanket. Their permanence is limited, however, replacement being required after perhaps two weeks' printing, and permanent thermoplastic adhesives have proved more satisfactory. These adhesives are coated on to the blanket and are only tacky when heated. Heat can be applied either directly to the adhesive layer or to the fabric, in order to achieve the required bond. Such thermoplastic adhesives often remain serviceable during the printing of several hundred thousand metres of fabric.

2.3.2 Squeegee systems

When flat screens are used for printing, the paste can be spread across the screen either along the length, or across the width. The latter has been used more, possibly because this was the tradition for hand printing narrow fabrics, but it also has the advantage that no pressure is exerted on already printed areas at the end of the stroke. One, two or more passes of the squeegee can be made as required. Again, hand-printing practice had an influence. The two most popular squeegee systems are described below.

Double-blade squeegee

This system is illustrated in Figure 2.7. A pair of parallel rubber-blade squeegees is driven across the screen with the print paste in the gap between them. Only the rear squeegee makes contact with the screen, the leading squeegee being raised slightly above it. When the next stroke is made, the leading squeegee for the first pass becomes the rear one for the reverse direction.

The double-blade arrangement is simpler to construct than one utilising a single squeegee that has to be lifted over the pool of print paste at the end of each stroke, although this type is found in some modern semi-automated machines.

Magnetic-rod squeegee

A completely different approach was adopted by Zimmer, who invented a rolling-rod squeegee moved by an electromagnet, driven intermittently under the blanket. This type of squeegee is used in Zimmer flat- and rotary-screen printing machines, except that the electromagnet is stationary in the latter case. In fully automatic flat-screen



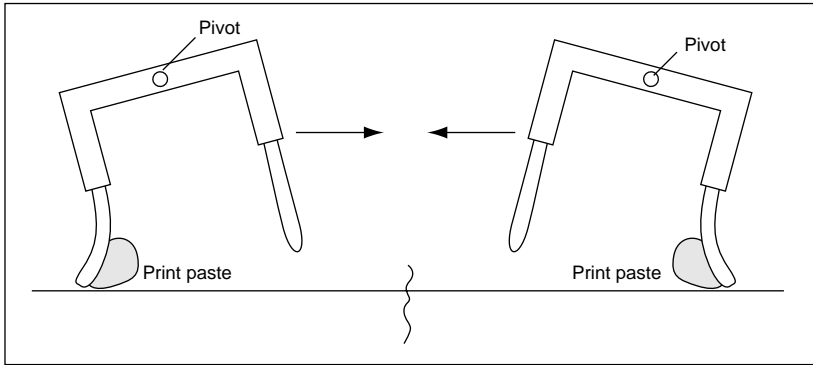

Figure 2.7 Double-blade squeegee arrangement

machines the rod rolls in the lengthwise direction and one passage is usually all that is required for adequate cover and uniformity. The diameter of the rod is usually small enough to allow print paste to flow over and round it at the end of a pass. It is clear that screen distortion and wear are less where rolling rods, rather than rubber-blade squeegees, are used.

2.3.3 Intermittent movement

The intermittent movement presents a variety of problems for engineers and printers, and these are summarised below.

Accurate movement of the blanket

It was discovered at the development stage that controlled movement of the blanket could not be provided simply by a motor-driven roller at one end of the machine. The blanket tended to slip and overrun, and a more positive control of the movement was required. Stretching of the long rubber-coated, laminated neoprene blanket also introduced inaccuracies. Some early machines incorporated a continuous metal strip along the edges of the blanket to reduce its extensibility and provide accurate edge location, but modern machines more often employ a series of electromagnetically or hydraulically operated clamps which grip the edges and move the blanket precisely one repeat distance without stretching it. The drive for the forward movement is usually hydraulic.



Discontinuity of gumming and washing

When water-based gums are being used, a line of excess gum is likely to be produced each time the blanket stops moving, which in extreme cases may affect the levelness of the print. The blanket, on its return passage, will also receive an irregular degree of washing. The Swiss company Buser have introduced an ingenious method of overcoming these difficulties which enables a blanket to move continuously on the return passage under the machine and in the feed-in unit. Guide drums at both ends act as compensators to allow the simultaneous, intermittent and continuous running of the blanket (Figure 2.6).

Control of fabric speed through the dryer

After the fabric has been printed it passes through the dryer, often being supported on a conveyor belt. Some machines also allow for the fabric to be supported between the end of the blanket and the entry to the dryer, particularly if the entry point is much higher than the blanket. Here also the intermittent movement may cause problems of variable stretching and overdrying. Ideally the fabric should move through the dryer at a constant speed equal to the average linear velocity of the blanket, but this is not always possible. The limits between which the fabric can be lifted off the blanket are the end of the last screen and the end of the top linear surface of the blanket. One technique often employed to maintain the fabric within these limits is to restrict the angle at which the fabric is removed from the blanket with the aid of photoelectric cells and light beams (Figure 2.8). When the fabric reaches light beam A the drive of

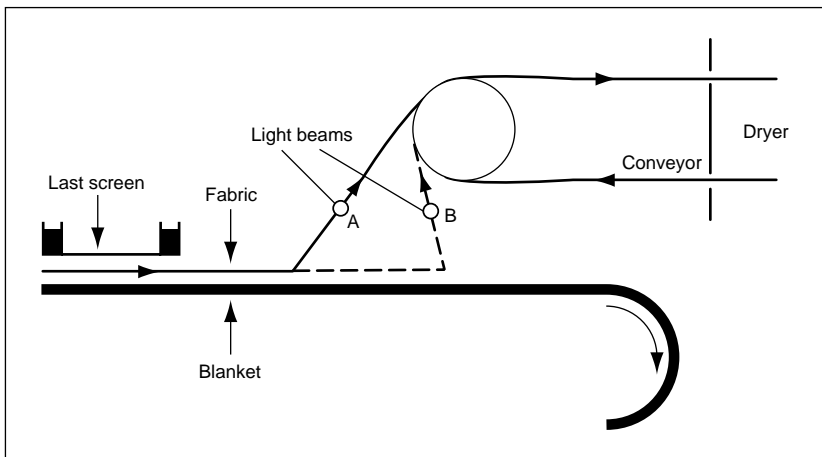

Figure 2.8 Photoelectric device to control dryer conveyor

the dryer conveyor belt is stopped and when it reaches light beam B the drive is started again. Alternatively, a single diagonal beam can be used.

2.3.4 Production rate

The production rate depends primarily on the time interval during which the fabric is stationary. The speed at which the blanket is advanced is much less important, as the blanket is in movement for considerably less time. Speed of advance has to be restricted, as at high speed the system would have so much forward inertia that there would be a tendency for the fabric to overrun the blanket.

The other factors that play an important role in the determination of the overall production rate are listed below.

Number of squeegee passes

Sometimes more than one pass is required to achieve uniformity and adequate penetration, especially in blotch areas. This applies particularly to thick fabrics and those with irregular surfaces.

In some machines the squeegees can be used to make a stroke while the screens are in the raised position (known as a 'flood stroke'). This fills the mesh in the printing areas of the screen with paste before the screen touches the fabric, and more colour is applied with the first stroke when the screen is lowered.

Repeat size

Where the squeegee movement is widthwise, the greater the lengthwise repeat the further the blanket moves forward at each pass; consequently the printing speed is greater. The effect is less marked if the squeegee movement is lengthwise, as the squeegee will take longer to move along the screen where the repeat distances are large.

Efficiency of the dryer

If the dryer is short, or if the temperature in the dryer is too low, the printing speed will have to be reduced in order to ensure that the printed fabric is adequately dried. This is particularly critical for designs in which a high proportion of the total area is printed (high percentage cover).



2.3.5 Printing faults

Some faults in automatic flat-screen prints are due to poor registration (misfitting of the colours in the design); others are associated with screen frames falling on wet areas of the printed fabric.

Registration

It has already been pointed out that accurate movement of the blanket exactly one screen-repeat distance, each time it is advanced, is essential for the correct registration of the colours in the design, and that inadequate adhesion of the fabric to the blanket will cause local misfitting. Another cause is screen distortion due to excessive drag exerted by the squeegee. This is especially likely where rubber-blade squeegees are used and the design contains large repeats.

Frame marks

When printing consecutive screen repeats, the screen frame inevitably falls on part of the area most recently printed and may leave an impression. This is a particularly difficult problem for blotch screens where large amounts of print paste are applied. The problem is reduced in hand screen and semi-automatic screen printing by printing alternate screen repeats and then moving back to fill in the gaps, but this is obviously not possible in automatic machines, since in these the movement of the blanket is always in the same direction. On the other hand, it is more serious in fully automatic screen printing as the printing speed is much higher, so that there is less time for intermediate drying or penetration of the fabric.

One technique used to avoid this fault is known as off-contact printing. The screen frame is lowered to a point only just above the blanket, the gap being so small that, as the squeegee passes and stretches the screen fabric, the printing area of the screen makes contact with the fabric being printed.

A related problem is the crushing of colours by succeeding screens, which is most serious when the screens are close together and the printing speed is high. Off-contact printing obviously reduces the problem and the screens should be spaced out as much as possible. If necessary, the printing speed is reduced. Printing a blotch as the final colour is also normal, to avoid this effect.

Splashing

When screens are lifted symmetrically after printing (that is, with the screen remaining horizontal), print paste in the space beneath the screen can often remain in contact



with the screen momentarily and then splash back on to the fabric. This can be avoided, or at least reduced, by lifting the screens at one side just before the other. Inevitably, however, this does slow down the overall printing speed a little.

2.3.6 Current utilisation

In the UK fully automatic flat-screen printing is primarily used for the printing of good-quality furnishing fabrics. The method is well suited to the large repeats and large motifs often used on these fabrics. In addition, the printing speeds are relatively low (300–600 m h⁻¹) compared with rotary-screen or copper-roller printing, and this allows time for any printing faults to be noticed and corrected before much expensive cloth is spoiled.

2.4 ROTARY-SCREEN PRINTING

Fully automatic flat-screen machines cannot be described as operating continuously, because their printing action is in fact intermittent. Continuous movement of the fabric has been achieved by moving the screens along with the fabric while printing (the American Precision Midas machine, for example, is of this type), but the use of rotary-screen machines has proved to be a simpler and more economical means of achieving this goal.

In rotary-screen printing, continuous rotation of a cylindrical screen while in contact with the fabric ensures genuinely continuous printing. Print paste is fed into the inside of the screen, and during printing is forced out through the design areas with the aid of a stationary squeegee. Figure 2.9 illustrates some of the squeegee types in use.

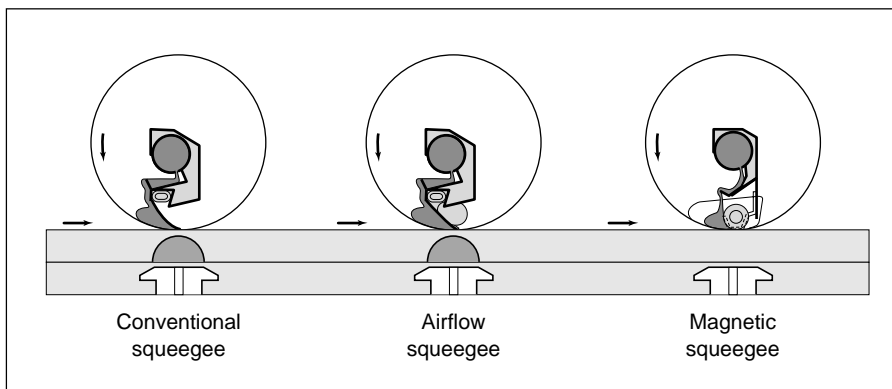

Figure 2.9 Rotary-screen squeegee systems (Stork Screens BV)

In the case of flexible-blade squeegees, the rotation of the screen in contact with the stationary blade builds up the pressure to force the paste through the screen. This is, of course, the converse of flat-screen printing, where the screen remains stationary while the squeegee moves.

A typical rotary-screen printing machine is shown in Figure 2.10. The design of most machines follows the pattern established for fully automatic flat-screen machines: an endless driven blanket, screen positions along the top, and blanket washing and drying effected underneath during the return passage. Provision for the use of a thermoplastic adhesive is common on rotary machines, with a curved-surface heating plate to heat the fabric before it is pressed on to the blanket. The cylindrical screens can be much closer together than is possible with flat screens and so the blanket is shorter (for a given number of colours). The fabric dryer, however, must be longer to enable the printed fabric to be adequately dried at higher running speeds. Typically, speeds of 30–70 m min⁻¹ are used depending on the design and the fabric quality. It is quite possible to run the machine faster than this, the limitations often being the length and efficiency of the cloth and blanket dryers and the difficulty of observing printing faults at high running speeds.

Print paste is often poured into flat screens by hand, even in fully automatic machines, but the continuous movement of a cylindrical screen and the restricted access necessitates automation of this operation. The print paste is pumped into the screen through a flexible pipe from a container at the side of the machine; inside the screen, the paste pipe has a rigid structure as it also acts as a support for the squeegee. Holes in the pipe allow the paste to run down into the bottom of the screen; since the paste is pumped in from one end, the holes need to be larger at the end furthest from



Figure 2.10 Rotary-screen printing machine (Stork BV)

the pump to achieve an even spread across the full width of the screen. A sensor (level control) actuates the pump when the paste level falls below a preset height.

2.4.1 Squeegee systems

The first squeegees used by Stork were of the traditional rubber type, but excessive wear of the rubber, due to the continuous movement, and the drag on the inside of the screens, which caused screen distortion, soon led to their replacement with flexible, stainless steel blades.

The curvature of the blade, and hence the angle of contact between the blade and the screen, changes according to the applied pressure, which can be readily altered by adjusting the bearings at both ends of the squeegee assembly.

Sideways movement is also possible so that the line of contact of blade and screen is not necessarily at the lowest point in the screen. Length and stiffness of the blade are also useful variables.

If the squeegee pressure is uneven, the volume of print paste applied across the width will vary, resulting in an unlevel appearance in the final print. This problem is most serious when printing wide fabrics, and special measures are used by some machine manufacturers to overcome it. For example, the Reggiani squeegee system consists of a phosphor bronze blade against which a rod is pressed by an inflated air sack, thus ensuring even pressure.

The Zimmer brothers continued to use the magnetic-rod squeegee system in their rotary machines. In machines with flexible-blade squeegees one boundary of the pressure wedge between rod and screen is stationary, but with rod squeegees both boundaries are moving (Figure 2.11). In most rotary machines there is a resilient bed under the screen position, and with high magnetic-field settings or when large rods are used the screen is likely to be distorted. This increases the contact area of rod and screen and, coupled with extra pressure introduced by the two moving surfaces, results in a higher minimum amount of paste being forced through the screen than with a stationary, metal-blade squeegee [4]. When printing lightweight synthetic fabrics or transfer paper, a metal blade is therefore often preferred to a rod.

Now that the original patents have run out, magnetic-rod squeegees and blades supported by air sacks (such as the Stork Airflow) are being more widely used. A full comparative analysis of magnetic-rod, blade and other types of squeegee used in rotary-screen printing has been carried out by Ferber and Hilden [5].

2.4.2 Setting-up to print

Although the walls of seamless nickel screens are only about 0.1 mm thick, they are



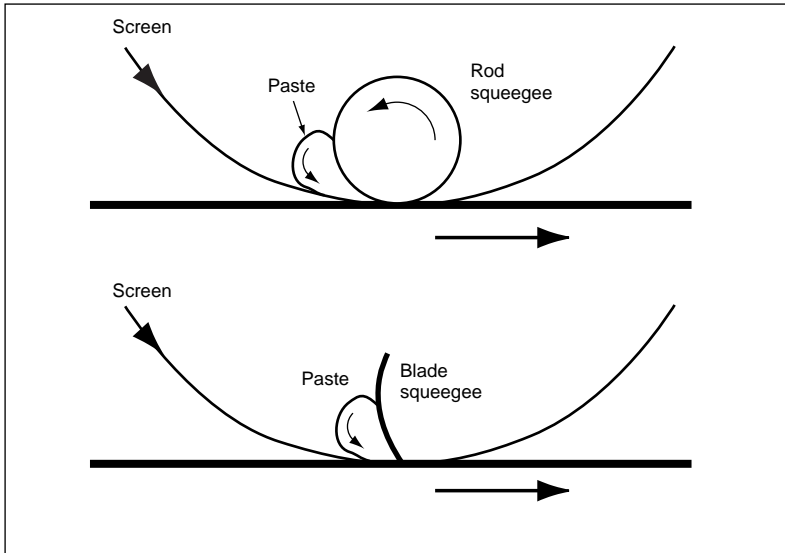

Figure 2.11 Rod and blade squeegees

strong enough to be rotated provided they are put under lengthways tension. Light aluminium alloy end-rings are fitted to the ends of the screen, care being taken that the plane of the ring is at right angles to the axis of rotation of the screen. Notches in the end-rings fit into the mountings (heads) on both sides of the blanket and a turn of the screen locks it firmly in position. Tension is then applied by moving the head furthest from the pump outward. The height of the heads can be adjusted so that the bottom of the screen is either just in contact with the blanket or higher up to allow for the thickness of the material being printed. When all the screens are in position, squeegee assemblies and level controls are fitted, and adjusted, and the flexible colour pipes connected.

Screen end-rings are usually fitted into closed bearings, but Peter Zimmer machines incorporate an open bearing system (Figure 2.12). This allows rapid screen changes, and readily accommodates variations in screen diameter.

When starting to print a multicoloured pattern the screens are adjusted while running in order to achieve registration of all the colours in the design. Several metres of fabric are wasted as a result. This problem has been overcome by German machine makers MBK, who have introduced a laser screen registration system for accurate alignment of rotary screens prior to printing. A red helium/neon laser beam shines down the length of the machine, and the screens are adjusted until the beam shines through the pitch marks.

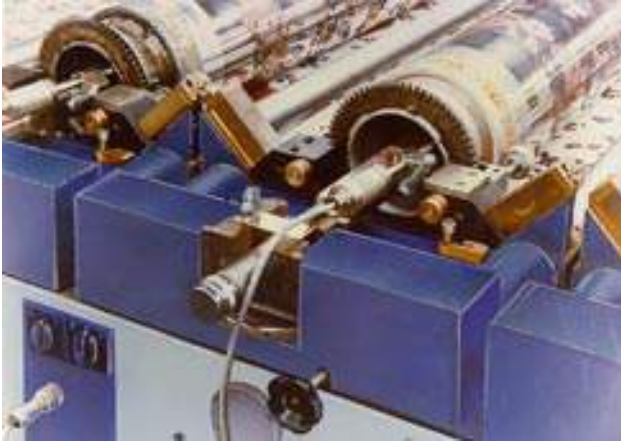

Figure 2.12 Open bearing (Johannes (formerly Peter) Zimmer)

2.4.3 Blanket and screen drives

Some rotary screens are driven from both sides to avoid the danger of twisting and buckling (Figure 2.13). If there is a direct link between the blanket and screen drives, correct fitting should be ensured even during speed changes, provided that the blanket does not slip on the driving rollers. The shorter blankets of rotary machines and their continuous motion substantially reduce the problems of extension and sideways movement often experienced with flat-bed machine blankets. Nevertheless, blankets of low extensibility are required.

The fitting of patterns during an extended printing run is sometimes less than satisfactory, especially with wide fabrics or when printing pile fabrics or carpets. One explanation, put forward by Peter Zimmer, is that these materials exert a considerable drag on the screens so that they are pulled round slightly in advance of their correct position. Eventually, at a seam perhaps, the screens will spring back and the pattern registration will be affected. Zimmer claims to be able to overcome this problem by running the screens at a slightly slower speed than that of the blanket. Stork have also introduced this facility into their most recent machine, which features independent speed control for each screen. MBK also make use of stepper motors for the same purpose.

2.4.4 Large repeats

The standard internal circumference of cylindrical nickel screens for printing textiles is 640.0–640.1 mm. A wide range of screen diameters may be obtained, however, as this





Figure 2.13 Rotary-screen printing machine showing printing heads, screens, connecting columns and screen drive shafts (Johannes Zimmer); one screen end-ring fits into a printing head (foreground) which includes squeegee support and setting fixtures; the end-ring at the far side is also driven by means of a drive shaft (left of screen); rectangular connecting columns on the left and right of the screen enable the position of the heads to be adjusted to suit various screen lengths

dimension depends solely on the diameter of the mandrel on which the screens are electroformed [6]. Rotary screens of circumferences 518, 537, 640, 668, 688, 725, 801, 819, 914 (the most common of the larger screens) and 1018 mm may be obtained as standard. But even the largest screens will not provide as large a repeat as a large flat-screen or a carpet loom. Following the jumper technique used in copper-roller printing, Peter Zimmer solved the problem of large repeats by using a system of intermittent raising and lowering of screens. A particular colour in the pattern might then be printed in sections by two or three screens. The design areas do not fill the complete circumference of the screens, the remaining blank portions being provided so that when the screens are in their raised positions print paste will not drip through them. Other machine manufacturers have also introduced this feature as an option.

2.4.5 Recent developments

Rotary-screen printing machines are expensive, and it therefore pays to keep downtime to a minimum. In their latest machine Reggiani have introduced the idea of washing screens between colourways on the machine. After printing the first colourway excess paste is pumped out of the screens, which are then sprayed with water from the inside while still in position on the machine.

Most manufacturers now offer microprocessor control coupled with computer management packages. All the essential data for a print run are recorded, including machine settings, so that when the design is printed again it can be set up much more quickly.

2.5 DESIGN ASPECTS

2.5.1 Design selection

When planning to produce and market a print, the design and fabric quality must first be selected. The design should suit the end-use envisaged: small motifs, stripes or checks for men's shirting, for example, or larger motifs and repeats for furnishing fabrics. The artist's original design, often called the 'croquis' (a French word), will probably not be drawn in repeat; it may moreover require amendment of scale and of the number of colours. At this point it is necessary to decide which printing method will be used, as the lengthwise repeat is subject to the limitations of the screens or rollers chosen; for example, the repeat is likely to be 64 cm or a simple fraction of this for rotary screens.

2.5.2 Repeat sketch

The individual design units (repeats) must fit together perfectly in order to avoid the appearance of discontinuities that become visible when long lengths of fabric are inspected. To this end, the croquis is redrawn to give a modified version known as a repeat sketch. At this stage the arrangement of repeats must also be fixed. Some common arrangements are shown in Figure 2.14.

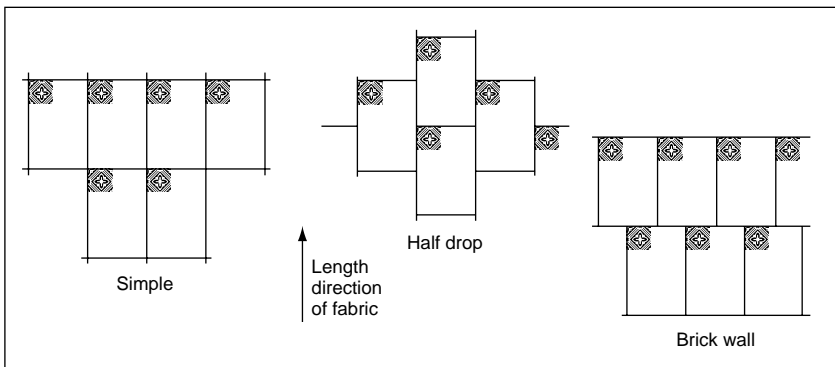

Figure 2.14 Repeat arrangements

During the preparation of the repeat sketch for a simple repeat, a repeat rectangle is often produced. This is halved vertically and horizontally, top halves then being moved to the bottom and left to right. The outer areas are then in repeat, and the central part has to be redrawn.

The boundary of the repeat in the final version is usually disguised by following the edges of motifs as much as possible – the ‘line of least resistance’ (Figure 2.15). It is particularly important that the boundary should not run through the middle of a blotch, as it would show up as a dark line in the final print. This is because a touch fit is very difficult to achieve, and so an overlap would have to be used (see below).

2.5.3 Colour separations

Once the repeat sketch has been produced, the next step is to separate the colours in the design. This is done by reproducing the design areas of each colour separately on a clear (or translucent) dimensionally stable film. The colour separations (or diapositives, as these painted films are termed) were usually hand-painted positives produced using opaque paint. This laborious process has now been automated by using programmed photoelectric scanners (see section 2.6.1).



Figure 2.15 The ‘line of least resistance’; the broken line indicates how the edge of the repeat skirts motifs and cuts across the shortest gap when the design includes a blotch

At this stage decisions must be taken with regard to the juxtaposition of the various colours in the design.

Overlap

Adjacent colours in a design for screen printing are usually made to overlap slightly, the degree of overlap depending on the type of design, the printing width and the nature of the fabric to be printed. If this precaution is omitted, unsightly gaps appear when registration errors occur during printing. The overlap is kept to a minimum as the third colour, formed when two colours overlap, can also be unsightly. In copper-roller printing a slight gap (or 'allowance') is left between colours at the diapositive stage (see section 1.3.3).

Design interpretation

In certain designs, particularly those containing tonal areas such as flower petals, it is advisable to print one colour on top of another. The result is known as a 'fall-on'. Usually, however, a space on the fabric is reserved (or 'saved') for each colour.

2.5.4 Step and repeat

Once a single repeat of the design has been redrawn in a suitable form it must normally be replicated in the correct arrangement (see above) so as to fill the screen, and cover the full width of the fabric to be printed. In flat-screen printing the design area should not reach the frame, as there must be room for the paste reservoir at the ends of each stroke of the squeegee, and at the sides the blade is unlikely to fit the width of the screen precisely. Such considerations do not apply to rotary screens, and here a whole number of repeats has to fit around the circumference. Thus for a 64 cm circumference screen, for example, the repeat must be 64 cm or a whole number fraction of this (32, 21.33, 16 cm and so forth).

When flat screens are being photopatterned multiple exposures of the positive for a single repeat are carried out directly on to the coated and dried screen, using a 'screen step-and-repeat' machine (see section 2.7.2). This method cannot be used for a cylindrical screen, and so for rotary screens (and for photogravure) the step-and-repeat process is carried out at the film stage. The single-repeat colour separation positive must first be converted into a negative, after which multiple exposures are made on to a large piece of photographic film. In both cases the borders round the single repeat must be carefully masked, so as to protect unexposed screen or film.



2.5.5 Registration

It is essential to include registration lines or crosses on each colour separation film during its preparation; often they are added in blue ink so that they do not show after exposure of the screen to blue light. They are lined up when the completed separations are checked for registration by placing them one on top of another over a 'light table' (a glass-topped table illuminated from beneath the glass). Pitch marks (Figure 2.2) are often used to check registration during printing.

2.6 COMPUTER-AIDED DESIGN

By far the most important developments in printing of recent years have been in the field of computer-aided design (CAD). Associated with these advances has come laser engraving, and also the proofing of designs on paper or fabric before screen engraving. All these depend upon the successful digitisation of the design, that is, the conversion of design information into binary code in a form that can be stored in the memory of a computer.

Until recently customers have generally placed orders after strike-offs have been submitted. (A 'strike-off' consists of a few metres of the correct fabric printed with each colourway of the design.) These are normally produced on a sample table so as to avoid interrupting work on the large-scale machine. Unfortunately, many of the designs that reach this stage are never printed in bulk, and so the expense of screen engraving has been wasted. The use of CAD substantially reduces the time taken to produce repeat sketches, colour separations and colourways; when the design system is linked to an ink-jet printer for proofing (see section 2.6.4), this may allow the decision to engrave screens to be delayed until orders are forthcoming [7].

2.6.1 Scanning

Although it is now possible to create a design on the colour graphics monitor of a CAD system using a 'Paintbox' or similar software package with a pressure-sensitive stylus or a mouse, most designs are still produced in the traditional manner, with paintbrushes or airbrushes on to paper or card. The original artwork is then digitised by means of a scanner. Design information is stored in the computer memory, one pixel (picture element) at a time. A scanner analyses the design one line (that is, one row of pixels) at a time, converting analogue colour information into digital form.

For small designs up to A3 size, a flat-bed desktop scanner will suffice. Typically such scanners use a single CCD (charge-coupled device) sensor for detecting the light reflected from parallel filtered red, green and blue fluorescent lamps, with a maximum scanning resolution of 300 dpi (dots per inch). The scanning speed varies with the



resolution, but the maximum is 30 ms per line. At this speed an A4-sized design takes 99 seconds to scan.

Larger designs require rotating-drum scanners, one of which is shown in Figure 2.16. This scanner utilises a xenon light source with red, green and blue interference filters, and a photomultiplier sensor. The width of the drum is 1160 mm and its circumference 1168 mm. The drum rotates at up to 900 rev min^{-1} and the resolution for colour work is $3\text{--}33 \text{ dots mm}^{-1}$ horizontal and $5\text{--}80 \text{ dots mm}^{-1}$ vertical. Digitised design information from the scanner is sent to the CAD system.

2.6.2 Colour reduction

The normal procedure is to scan a design at relatively low resolution, and then display it on a colour monitor. At this stage any variations in colour, whether intentional or not, will show, and the software allows the design to be divided into a large number of colours. The next step is colour reduction, whereby the design is simplified into a manageable number of colours. After further editing the design is then rescanned at a higher resolution.

2.6.3 CAD operations

A typical CAD software package will allow a large number of manipulations to be carried out. Options would probably include:

- putting the design into repeat, e.g. quartering for a simple repeat
- scaling the design to fit screens



Figure 2.16 Drum-type colour scanner interfaced to CAD system (Stork Screens BV)



- drawing and brushing
- Mirror, Inverse and Replicate functions
- overlap
- fall-ons
- capturing, copying, moving and scaling motifs
- zooming in on small areas in order to edit them
- filling in colours
- changing colours
- shading and stippling
- colour separation
- dot removal (deleting stray dots in a colour separation).

Optical discs are becoming the most common way of storing design information, replacing magnetic tape. The capacity of currently available optical discs is up to 600–650 Mbytes, while a typical design may require 20–100 Mbytes.

When the designer is satisfied, design information can be downloaded to a film plotter or laser engraving machine via an Ethernet link, but more often it is quicker to transfer the disc by hand. Nowadays, more and more screens are being engraved without the need to produce colour separations on film [7].

2.6.4 Proofing

The hardware associated with most CAD systems will include a colour printer. ‘Proofing’ is the term used for the production of initial coloured hard copy in the graphics industry, and it is becoming accepted in textile CAD parlance.

There are several varieties of computer-controlled colour printer, including ink-jet, thermal and sublistatic. Of these, ink-jet printers are the most widely used. Jet printing has been thoroughly reviewed by Dawson [8]. The manufacturers of ink-jet printers use various methods of creating a large ‘palette’ of colours, but they all utilise the subtractive primaries (cyan, magenta and yellow) and, usually, black for the ink colours (so-called CMYK printing).

An extended range of colours can be produced by the following means:

- using several concentrations or jet diameters for the primary inks (for example, the Canon FP 510 has three levels each of cyan and magenta, and one of yellow and black)
- varying the dot size (for example, the Stork Ink-Jet uses streams of tiny charged droplets, and up to 32 of these coalesce as a dot on the paper)
- using a ‘dither pattern’, that is, a spatial arrangement of dots of the primaries within a grid or ‘matrix’.



When a dither pattern is used there has to be a compromise between the number of squares in the matrix and the resolution of the printed design. Thus, if a 2×2 matrix is used the number of colours in the palette is smaller than if a 4×4 matrix is used, but the resolution is twice as high.

Proofing with ink-jet printers is currently being heavily promoted, but there are two major drawbacks. In charged-drop printers the ink is flowing continuously; thus a small design on a large white ground uses as much ink as a design with 100% cover. As a result, expensive ink is wasted if the design requires no ink at a particular point. The other problem is that jets can get blocked, and care must be taken to flush out with solvent when the printer is not in use.

The resolution of paper printers is often as high as 400 dpi, much higher than the mesh in rotary screens. The quality of hard copy obtained from CAD systems using ink-jet printers is high, and a wide selection of colourways and design variants or coordinating designs can be presented to customers. Matching the colour of the paper print (under specified lighting) to the colour on the display requires the printer to be calibrated (characterised) [9]. Colour fidelity from screen to fabric is best achieved via synthetic reflectance curves and computer match prediction [10,11].

Print producers have, however, always shown a reluctance to accept representations of designs on paper. Process inks designed for printing on chalky coated paper do not print very satisfactorily on to fabric. As a result Stork, in conjunction with ICI (now Zeneca), have developed a new ink system designed for printing on to fabric [12]. The inks contain highly purified reactive dyes, and are suitable for printing on to specially prepared cotton, rayon, wool and silk fabrics. The strike-offs or 'proofs' are steamed and washed off as usual. The Trucolor printer was launched by Stork at the 1991 ITMA machinery show. No doubt other jet printers will follow, using disperse dyes of low r.m.m. (molecular weight) for transfer printing on to synthetic fibres.

Conventional direct printing of textiles, however, does not use half-tone CMYK techniques, but instead involves every colour in the design being printed through a separate screen. The question therefore is bound to be whether the proofs, even when printed on to fabric, adequately resemble the final production printed through screens.

2.7 SCREEN PRODUCTION

2.7.1 The photochemical process

Some polymers, in the presence of a sensitizer, will crosslink when exposed to blue or ultraviolet light and so become insoluble. The polymers most used in the preparation of textile printing screens are mixtures of poly(vinyl alcohol) and poly(vinyl acetate), sensitised with a dichromate salt such as sodium or ammonium dichromate, or a 'diaz



resin' (condensation product of formaldehyde (methanal) and *p*-diazodiphenylamine). The poly(vinyl acetate) is added as a dispersion and acts as a cheap filler, but also increases the solids, improves the edge quality and imparts some water resistance to the finished stencil.

Other photosensitive polymer systems have been used for screen making, notably the stilbazole system developed in Japan [13].

In the photochemical method for preparing a textile-printing screen, the screen is coated with photosensitive polymer solution, dried, exposed through the positive and washed with water, all under dark-room conditions. The areas of unexposed polymer coating are washed out of those parts of the screen fabric through which the print paste will pass.

The term 'engrave' is commonly used for the photochemical process described above, but perhaps 'photopattern' would be preferable, since strictly speaking 'engraving' usually implies etching a metal surface.

2.7.2 Flat screens

Screen frames for commercial use are usually made of steel, or a lighter metal, with a hollow cross-section to provide rigidity with minimum weight. The coarser screen-mesh fabrics are usually woven from polyester multifilament yarns, which are cheaper than the monofilaments preferred for fine-mesh screens. Screen fabrics used for printing on to paper, in the graphics industry, are sometimes calendered to reduce the open area and thickness, and are often coloured red or orange to reduce the level of light scatter during exposure, but this degree of sophistication is rarely necessary for textile printing. The choice of screen fabric depends on the fabric and design to be printed. Table 2.1 provides a guide.

In many screen-printed fabrics the edges of the printed areas appear serrated,

Table 2.1 Choice of screen fabrics

	Threads/cm ⁻¹	Open area/%
Terry towelling	19–34	47–43
Large blotches, furnishing fabrics	4–49	47–40
Large blotches on smooth fabrics	43–55	43–39
Small motifs	49–62	41–34
Details and outlines on coarse fabrics	55–62	41–34
Outlines, half-tones, fine fabrics, synthetic fabrics	55–100	41–27



although they were smooth curves or straight lines at the colour separation stage. This is known as the 'saw-tooth effect' and is an almost inevitable consequence of the design area consisting of a regular array of threads and spaces. The boundary of any motif that is not exactly parallel with the threads in the screen fabric will be stepped, since the holes between the threads are approximately square. Spread of the paste underneath the threads is essential for successful coverage of the fabric, and this tends to reduce the effect; nevertheless it is often visible, especially when coarse screen fabrics are used. The use of fine-mesh screens enables small quantities of low-viscosity paste to be applied, giving rapid but limited penetrations, good colour yield, unbroken fine lines and geometrical objects with minimal saw-tooth effect.

The selected screen fabric is cut to size and stretched, for which pneumatic tensioning equipment may be used. It is then fastened to the frame with a suitable adhesive and degreased (for example, by soaking with 5% caustic soda solution, rinsing and neutralising with dilute acetic acid). A flat screen is coated by standing it against a wall and applying the layer of viscous polymer solution with the aid of a smooth, straight-edged trough by moving the tilted trough from the bottom to the top. The coated screen is dried in a dark cupboard, ideally on a horizontal shelf, with a draught of cool, dust-free air. The coated screen is sensitive to light, and photographic dark-room conditions with safe lights are required during the exposure and developing stages.

Frequently, a number of repeats are to be reproduced on a screen and in these cases it is normal to use a step-and-repeat machine. A positive of the single repeat is fixed to the glass of a light table and the remaining area of glass is blacked out with opaque paper. The coated screen is mounted on a carriage, the sideways movements of which are carefully monitored. After one exposure the screen is moved the exact distance required for the next repeat and a second exposure is carried out, and so on until the screen is completed. (The contact between positive and coated screen is often improved by employing a flexible cover and reducing the pressure between glass and cover.) The screen is then soaked in a tank of water and lightly sprayed to remove the unexposed polymer. After drying and painting out any small holes (pinholes), it can then be reinforced with lacquer (cellulose or polyurethane), the lacquer being removed from the printing areas by suction. As an alternative, some photosensitive polymeric coatings can be further hardened after 'photopatterning' by a second exposure to light or by a heat-curing process.

A method of photopatterning flat screens without the use of colour separation films has been developed by Gerber Scientific in the USA. A computer-controlled printer applies an ink containing a water-soluble polymer and a black pigment to a previously coated screen, the coating being the conventional light-sensitive type. The screen is then exposed to light and washed in the usual way.



2.7.3 Rotary screens

Lacquer screens

Lacquer screens, introduced by Stork in 1963 but now available from several manufacturers, have uniformly spaced hexagonal holes arranged in lines parallel with the axis of rotation of the cylinder and offset in alternate lines, as in a honeycomb, for maximum strength. The walls of the holes through the thickness of the screen are sloping, so that the holes are larger on the outside of the wall than on the inside (Figure 2.17). In the screens used for printing textiles the open area, measured on the inside of the screen, varies between 9 and 13% of the total.

Lacquer screens are manufactured by electrodeposition of nickel on to a mill-engraved mandrel [6]. The mandrel is a cylindrical steel roller which is coated with a thin layer of copper by electrodeposition and engraved with the required hexagons using a milling machine. The mill is a small, hardened steel cylinder with the design standing out from the surface (see section 1.3.3). It is pressed against the polished copper and moves along the length slowly while the mandrel and mill are rotated, producing a spiral pattern with no seam.

The hexagon-shaped recesses must next be filled with a polymer which acts as an electrical insulator, after which the copper surface is protected by nickel (or chromium) plating followed by a further filling in of the recesses up to the outer plating level. If the mandrel is nickel-plated it is then passivated (coated with a thin layer of oxide) with chromic acid, in order to prevent it from fusing to the nickel screen. It is then immersed in the nickel-plating bath where it becomes the cathode, while the anode consists of nickel lumps held in nylon bags contained in titanium baskets along the sides of the bath. The composition of the plating bath has not been published, but the nickel compound used is usually nickel sulphate or nickel sulphamate. Other

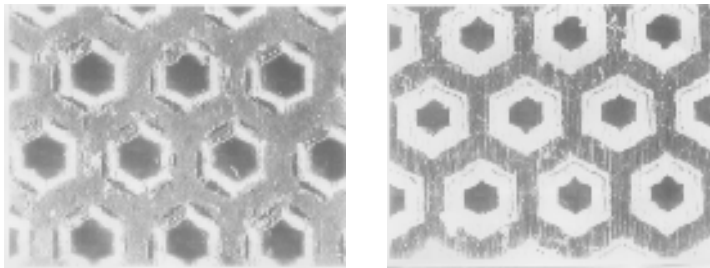

Figure 2.17 Holes in lacquer screens, seen in reflected light ($\times 50$); (left) outside: the sloping sides of the holes are in shadow and barely visible; (right) inside: the holes show as black areas, those areas where the insulator has been bridged during electrodeposition (see Figure 2.18) appear grey, and those where the nickel has been in contact with the mandrel appear white



common constituents are boric acid and an organic compound such as saccharin, which helps to reduce stress in the electrodeposited layer.

When the nickel layer is about 0.1 mm thick the mandrel is removed from the bath and hosed down, and the nickel screen detached from the mandrel.

As the thickness of the nickel layer builds up it gradually bridges across the insulator (Figure 2.18) so that eventually the holes are blocked. This means that it is not possible to produce screens finer than 100 mesh (holes per linear inch) by this technique, and the finer the mesh the thinner is the wall. The most popular screen meshes are 60 mesh for blotches and motifs and 80 mesh for outlines and synthetic fabrics.

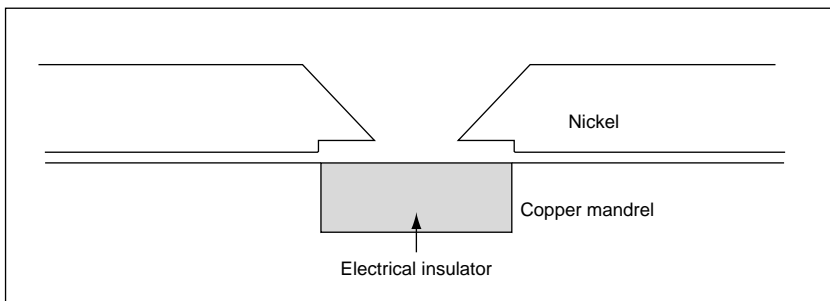

Figure 2.18 Bridging of insulator

Manufacturers of rotary screens have been fully aware of their deficiencies [14]. In particular, the relatively coarse mesh, compared with the fine-mesh fabrics which are available for flat screens, meant that the definition left room for a great deal of improvement, in particular that of fine lines and at the edges of motifs and stripes.

This kind of consideration prompted Stork to modify their electrodeposition procedures. Screens made by the process described above are often described as 'electroformed'. It is widely believed that in the production of finer-mesh electroformed screens the screens are removed from the mandrel and then reimmersed in the plating bath – the so-called 'electroless' process. Stork have introduced lacquer screens known as PentaScreens [15], and more recently, NovaScreens. The two variants are shown in Figure 2.19, and their specifications are given in Table 2.2.

The 125 mesh PentaScreen has a percentage open area similar to the original 60 mesh screen, and the 185 mesh the equivalent to the 80 mesh screen. The profile of each hole from inside to outside is rather different, being narrowest in the centre of the wall, like that of an hour glass. With the new screens it is possible to print a line 0.12 mm thick, which is half the minimum width obtainable previously.

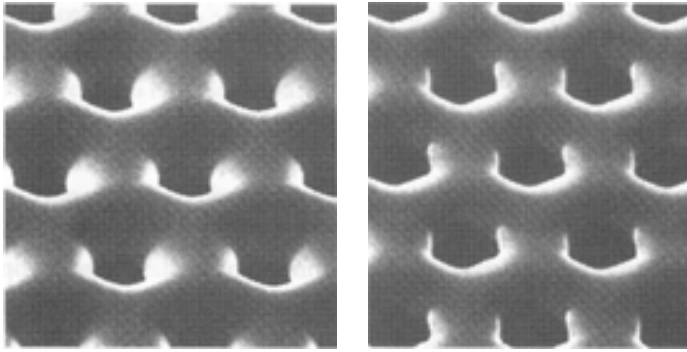

Figure 2.19 Stork PentaScreens (left) and NovaScreens (right) (Stork Screens BV)

Table 2.2 PentaScreens and NovaScreens

PentaScreens		NovaScreens	
Mesh	Open area/%	Mesh	Open area/%
125	15	135	24
155	16	165	21
185	11	195	18
255	7		

NovaScreens feature a combination of high mesh counts and holes that are larger than in equivalent PentaScreens. This favours half-tones (see section 2.7.4), and also allows printing with pastes with high pigment loadings, such as whites and metallics. NovaScreens are slightly thicker than PentaScreens, which makes them less subject to creasing.

The method of introducing the design on to the screens is similar to that used for flat screens, except that the shape of the screens necessitates modifications in the details. A full-size (full-out) positive is usually prepared for rotary screens to avoid the need for multiple exposures of the screen on a step-and-repeat machine.

Stork introduced the annular squeegee for coating screens by hand with photosensitive polymer, starting at the bottom and moving upwards. Modern screen-coating units, however, apply one thick layer of highly viscous emulsion, starting at the top and moving down (Figure 2.20). Besides poly(vinyl alcohol), the lacquers used contain other polymers that promote good adhesion to nickel, such as melamine formaldehyde resin.



Figure 2.20 Semi-automatic rotary-screen coating machine (Stork Screens BV)

The coated and dried screen is placed on an inflatable rubber tube and the full-size positive wrapped round it. The film is carefully positioned on the screen with the aid of the reference lines, using a sliding pointer attached to the exposure machine. This allows the other positives to be aligned correctly on their respective screens. Special care is taken that the junction is accurate, and in this respect greater precision is achieved if the join is nonlinear, as sideways slippage is thus avoided. The rubber tube is then inflated to ensure good contact between screen and positive and the assembly is rotated while the screen is exposed to an ultraviolet light source.

Galvano screens

The other type of rotary nickel screen, called the galvano screen by Peter Zimmer, is manufactured quite differently. The design is introduced at the same time as the nickel is electrodeposited. This means that the nondesign areas are solid nickel instead of a uniform mesh filled with a thin layer of lacquer.

They are therefore stronger and less susceptible to pinholes.

A mandrel similar to that used for the manufacture of lacquer screens can be used for the preparation of galvano screens, but Peter Zimmer designed a thin, inflatable nickel tube, known as a matrix, to replace the mandrel. The matrix (or mandrel) is first coated with photosensitive polymer. A full-size negative of the colour separation is required. This is wrapped round the hollow matrix together with a second film on which the required grid pattern is reproduced (Figure 2.21), and the matrix is inflated to provide close contact. The coated matrix is then exposed and washed in the normal way. At this stage the nondesign areas and the supporting mesh in the design areas are free from polymer. Besides defining the design areas, the polymer also acts as a dielectric resist (insulator). The matrix is then mounted in a nickel-plating bath and the nickel screen built up in the same ways as for the lacquer screens. Bridging of the insulator is a more serious problem with galvano screens, and a nominal 80 mesh screen is the finest that can be reliably manufactured.



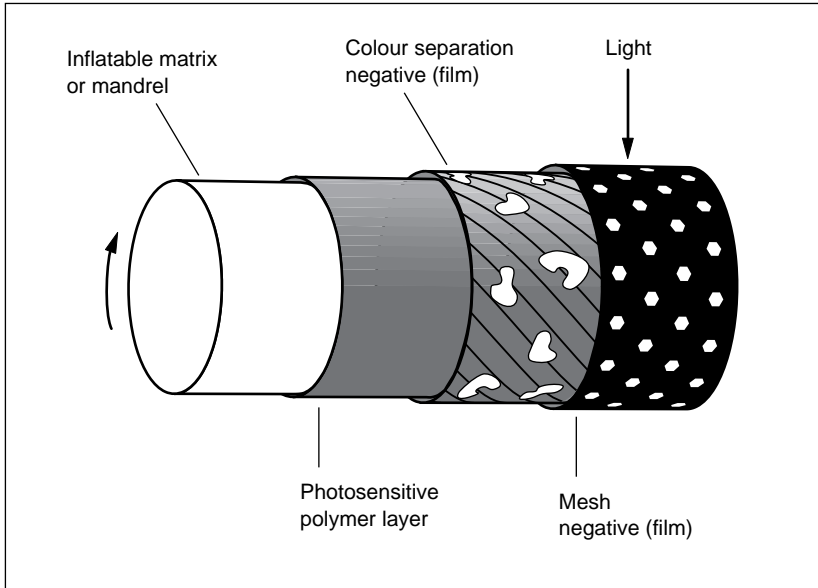

Figure 2.21 Galvano screen manufacture: the exposure step

The pros and cons of the two types of screen are well balanced. For narrow fabrics and fine patterns lacquer screens are probably the best choice, whereas the extra strength of galvano screens has advantages for wide-width printing, especially for rigorous conditions such as those encountered in carpet printing. In this case the wall thickness is 0.35–0.4 mm, instead of the 0.08–0.1 mm used for textiles, and the mesh is much coarser.

2.7.4 Half-tone and multi-tone printing

Half-tone printing (that is, a gradation of tones within one coloured area) is not easy to achieve by screen printing, although it is a common feature of copper-roller prints both on paper (gravure) and fabric (intaglio). Confusion is sometimes caused by the use of the term in the textile field, where it often indicates just two tones, one roughly twice as dark as the other. Half-tone illustrations for screen printing on paper are prepared with the aid of a cross-screen grid which breaks up continuous tones into rows of dots of different sizes, large dots for dark areas and small dots for paler areas. When half-tone positives produced in this way are used to prepare printing screens, interference patterns, known as moiré patterns, are likely to occur unless the angle of the positive relative to the printing-screen mesh is carefully adjusted.

In recent years, with the advent of fine-mesh screens and laser engraving, tonal printing with rotary screens has become possible.

2.7.5 Laser engraving

Laser light (the acronym comes from ‘light amplification by stimulated emission of radiation’) is highly monochromatic, polarised, coherent and powerful. The use of high-powered lasers for engraving screens is a development from their use for engraving rubber-covered flexographic printing rollers (discussed in section 3.2.2).

The leaders in the laser engraving field have been the British company ZED and Schablonentechnik Kufstein (STK) of Austria. Initially the process was restricted to lacquer-type rotary screens, carbon dioxide (infrared) lasers being used to burn away the lacquer. A thin, even coating of a nonphotosensitive lacquer is applied to the screen, usually starting at the bottom of the cylinder. Electrophoretic coating can also be used [3]. The term ‘engraving’ is more satisfactory for this method of putting the pattern on to a screen.

More recently, however, flat-screen laser engraving has been introduced by Luscher (Switzerland) and Meccano Systeme (Italy), the development work having been carried out by Mografo A/S (Denmark). The polyester mesh of flat screens would be burned away along with the lacquer by a carbon dioxide laser, and so a photosensitive lacquer is exposed to a computer-controlled argon ion laser (blue-green).

A typical rotary-screen laser engraving machine is shown in Figure 2.22. It features a 1000 watt class 4 industrial laser, sufficiently powerful to allow the machine to be employed for stripping all the lacquer off used screens so that they can be used again.

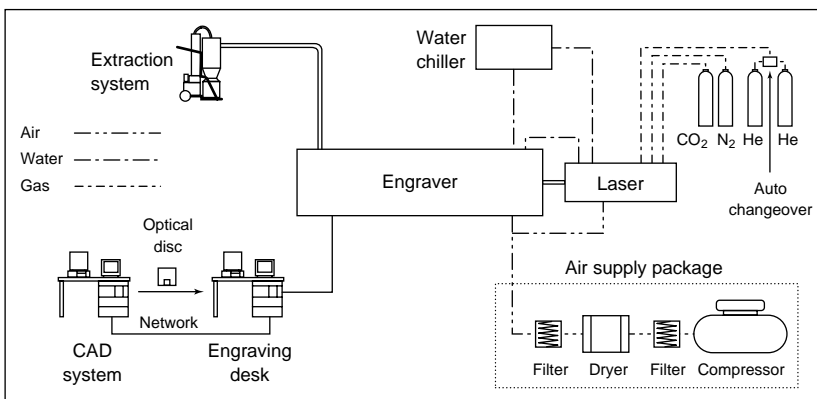

Figure 2.22 Typical configuration of a laser engraving unit (ZED Instruments)

The laser requires supplies of nitrogen and helium as well as of carbon dioxide, and the infrared beam ($10.6\ \mu\text{m}$) is passed from the generator (on the right in Figure 2.22) down the length of the engraving unit. It is deflected at right angles by a mirror and focused by a lens on to the screen. Care is taken to remove all the degraded lacquer with a powerful suction and filter unit, so as to avoid contamination of the optical system.

The coated screen, having been mounted in the engraving unit, must be held precisely in position while it is being engraved. A moving hardened steel guide ring with a diameter slightly larger than the screen has been patented by ZED. The ring runs in three roller bearings which are mounted on the same carriage as the engraving head (Figure 2.23). When a screen is being loaded or unloaded the guide ring is concentric with the screen position. For engraving, the guide ring is moved off-centre, away from the engraving lens. This brings the ring into contact with the screen under light pressure. As the screen is rotated the ring turns at the same speed, so there is very little friction between screen and ring, but it is sufficient to hold the screen securely in position. During engraving the ring moves with the carriage, in front of the beam.

The ZED machine engraves at up to $1.2\ \text{m s}^{-1}$, with a rotation speed of $1000\ \text{rev min}^{-1}$, resolution being typically $100\ \mu\text{m}$ for blotches, and $50\ \mu\text{m}$ for fine lines and fine-mesh screens. Fast conversions of the data formats from a range of CAD systems are available.

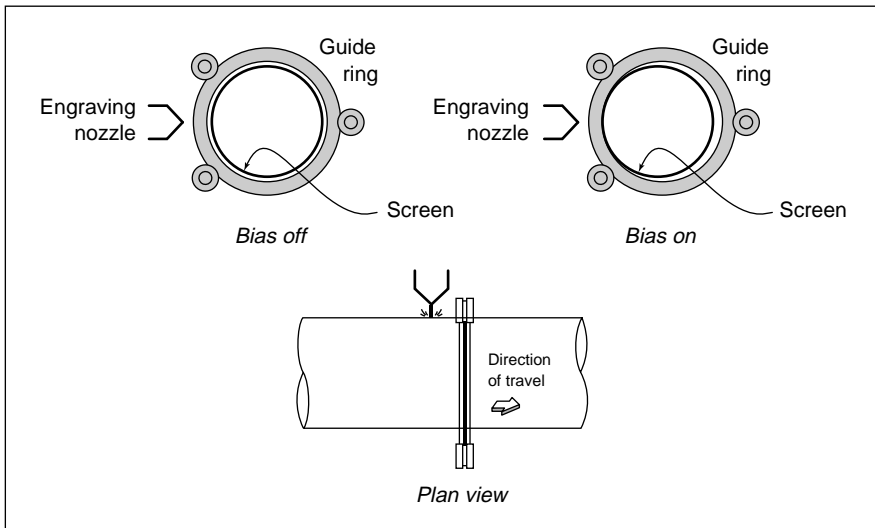

Figure 2.23 ZED Instruments guide ring system (ZED Instruments)

2.8 THE FUNDAMENTAL MECHANISM OF SCREEN PRINTING

In all screen-printing processes a hydrodynamic pressure is developed in the wedge of print paste that lies between the squeegee and the screen. Where a rod or roller squeegee is used, two moving surfaces bring their boundary layers of paste into the wedge and the pressure is higher than with a comparable blade squeegee, other factors being equivalent (Figure 2.11). However, the quantity of paste finally applied to the fabric depends not only on the magnitude of the pressure, but also on the restrictions imposed by the holes in the screen and by the receptivity of the fabric being printed.

2.8.1 Hydrodynamic pressure in the paste wedge

The downwards force F (Figure 2.24) on the squeegee is necessary to produce the required angle and to prevent the blade being lifted off the screen, but otherwise has little effect on the hydrodynamic pressure in the paste wedge except that due to any distortion of the screen which may alter the effective squeegee angle.

The hydrodynamic pressure is increased by:

- decreasing the squeegee angle (hence sharp squeegee blades apply less colour than rounded ones)
- increasing the base length of the pressure zone b
- increasing the speed of movement of the squeegee v
- increased paste viscosity η
- reduced screen-pore radius r .

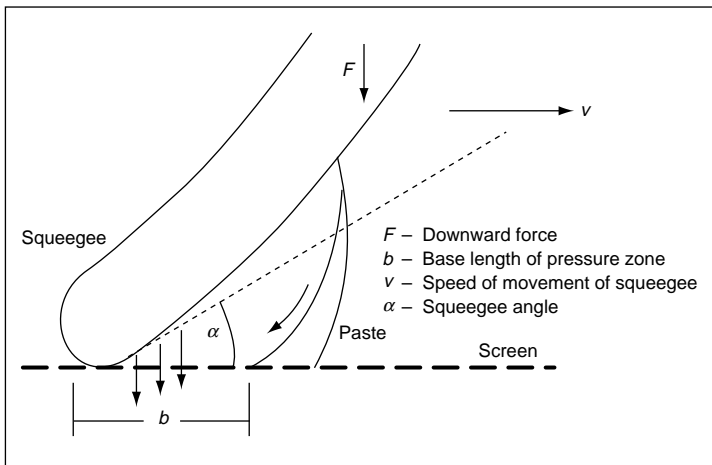

Figure 2.24 Pressure profile of the paste wedge

2.8.2 Flow of paste through screen pores

Simple flow through holes in screens can approximately be described by the Poiseuille relationship (Eqn 2.1):

$$Q = \frac{P r^4}{8 \eta l} \quad 2.1$$

where Q is the quantity of the paste flowing through a hole of length l (related to the screen thickness) and radius r , and P is the pressure drop across the hole.

The variables r and η appear in this expression twice, since the pressure drop is produced by the hydrodynamic pressure in the paste wedge and, as has been observed already, this also depends on r and η . The hydrodynamic pressure is inversely proportional to the radius (or to a power of the radius not likely to exceed 2) and thus Q is proportional to r^3 (or r^2). Hence, pore radius has a large effect on the quantity of paste that will flow through a screen.

The hydrodynamic pressure is probably directly proportional to the paste viscosity η , in which case its effect on the quantity of paste flowing through the screen is likely to be negligible.

In addition to the pore size, the percentage of open area (porosity) of the screen has a direct effect on the quantity of paste flowing through a screen, more open screens allowing more paste to pass through.

2.8.3 Uptake of paste by fabric

A variable not mentioned so far, except in discussing the choice of screen mesh, is the nature of the fabric being printed. The three-dimensional form of the fabric (that is, the amount of free space between yarns and fibres), the absorbency of the fibres and penetration between yarns will all affect the uptake of paste. Penetration occurs through the thickness of the fabric, mainly due to the pressure and kinetic energy with which the paste leaves the pores, but sideways spread due to surface tension forces is restricted by the higher viscosity of pseudoplastic pastes under low shear conditions (see section 7.7.3). Some work has been carried out on the fundamentals of the flat-screen printing process [14,16,17], and also on rotary-screen printing [4,5].

2.9 NONTEXTILE APPLICATIONS OF SCREEN PRINTING

The versatility of screen printing is well illustrated by the diversity of applications for which the technique is used. Examples include the production of advertising posters,



ceramics, wallpaper, packaging and printed circuits. The explanation for this diversity is the wide range in the type and quantity of ink that can be applied through screens.

2.9.1 Screen printing paper

Less ink is required for adequate coverage when printing the relatively smooth surface of paper than for a more markedly three-dimensional textile. The manufacture of fine-mesh monofilament polyester screen fabrics, which can be calendered to reduce the open area still further, allows the successful application of smaller quantities of ink.

Solvent-based inks are usually employed for paper printing, as these dry sufficiently quickly to allow rapid production. The use of solvents in inks has disadvantages, however, as photosensitive screen lacquers having good solvent resistance must be used and solvent sprays are necessary to remove ink from screens after printing.

In the graphics industry the images that are printed on to paper must be as sharp and clear as possible. The use of indirect stencils [21] has catered admirably for this requirement. The technique entails the use of a photosensitive coating, usually gelatin-based, on a clear plastic film. After exposure to actinic light, through a positive of the design, the coated film is washed in warm water and, while still damp, is brought into contact with a prestretched screen mesh. Drying produces good adhesion, after which the plastic support film can be peeled off and the screen is ready for use. The chief advantage of this approach is the excellent image resolution obtained due to the fact that no mesh interference takes place while the stencil is being exposed.

Screen printing of transfer paper

Since the advent of transfer printing, rotary-screen machine manufacturers have gone to some lengths to show that it is possible to print paper without intermediate drying on these machines. The amount of paste applied by the method is much greater than by gravure or flexographic printing (Table 2.3), and heavy (about 70 g m^{-2}) absorbent paper is required.

Table 2.3 Approximate quantities of ink applied to paper

Printing method	Ink applied/ g m^{-2}
Gravure	5
Flexographic	7
Rotary screen	15



The new generation of fine-mesh screens, such as Stork PentaScreens [15] and the more recent NovaScreens (see section 2.7.3), have proved very useful for this process. It was pointed out earlier that blade squeegees apply less paste than rolling rods, and should therefore be more suitable for printing transfer paper. Zimmer, however, are still promoting magnetic-rod machines for transfer paper printing [22], particularly for wide widths. They have also designed a machine bearing a resemblance to the Aljaba duplex machine, with the paper being printed while vertical, with support rollers behind each screen, and no blanket (Figure 2.25). This competes with gravure machines for quality of printing, but at widths up to 2.2 m.

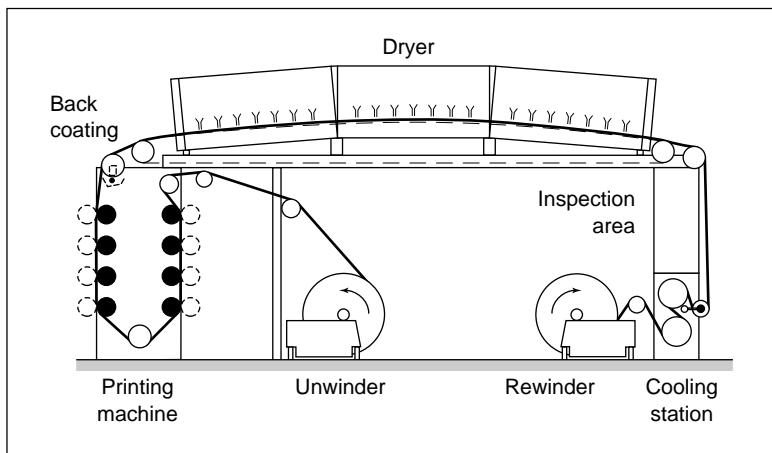

Figure 2.25 Rotary-screen printing machine for transfer paper (Johannes Zimmer)

REFERENCES

1. J Storey, *Manual of textile printing* (London: Thames & Hudson, 1992) 110.
2. J C de Barros, *J.S.D.C.*, **82** (1966) 3.
3. W W Sword, European P 0 020 409.
4. C J Hawkyard and A S Miah, *J.S.D.C.*, **103** (1983) 27.
5. U Ferber and J Hilden, *Melliand Textilber.*, **70** (1989) 705 (E303), 775 (E331), 865 (E372).
6. F Darlington, *Text. Ind.*, **134** (Nov 1970) 98.
7. J Spruijt, *J.S.D.C.*, **107** (1991) 75.
8. T L Dawson, *Rev. Prog. Coloration*, **22** (1992) 22.
9. R Luo *et al.*, *J.S.D.C.*, **108** (1992) 516.
10. C J Hawkyard, *J.S.D.C.*, **109** (1993) 246.
11. C J Hawkyard, *J.S.D.C.*, **109** (1993) 323.
12. S O Aston, J R Provost and H Masselink, *J.S.D.C.*, **109** (1993) 147.
13. Murakami Screen Kabushiki Kaisha, European P 0 130 804.

14. M Klemm, *Melliand Textilber.*, **54** (1973) 521.
15. S M Suchecki, *Text. Ind.*, **142** (Nov 1978) 71.
16. M Cropper and C Butler, *Prof. Printer*, **18** (6) (1974) 14.
17. B F Dowds, *J.S.D.C.*, **86** (1970) 512.
18. L W C Miles, *Textile printing* (Watford: Mellow, 1971) 22.
19. P Kassenbeck, *Melliand Textilber.*, **61** (1980) 522.
20. I Hardalov, *J. Textile Inst.*, **83** (3) (1992) 449.
21. J W Bird, *Prof. Printer*, **19** (6) (1974) 9.
22. R J P Zimmer, *Dyer*, **177** (May 1992) 24, 36.



Contents



Home

CHAPTER 3

Transfer printing

Ian D Rattee

3.1 INTRODUCTION

Transfer printing is the term used to describe textile and related printing processes in which the design is first printed on to a flexible nontextile substrate and later transferred by a separate process to a textile. It may be asked why this devious route should be chosen instead of directly printing the fabric. The reasons are largely commercial but, on occasion, technical as well and are based on the following considerations.

1. Designs may be printed and stored on a relatively cheap and nonbulky substrate such as paper, and printed on to the more expensive textile with rapid response to sales demand.
2. The production of short-run repeat orders is much easier by transfer processes than it is by direct printing.
3. The design may be applied to the textile with relatively low skill input and low reject rates.
4. Stock volume and storage costs are lower when designs are held on paper rather than on printed textiles.
5. Certain designs and effects can be produced only by the use of transfers (particularly on garments or garment panels).
6. Many complex designs can be produced more easily and accurately on paper than on textiles.
7. Most transfer-printing processes enable textile printing to be carried out using simple, relatively inexpensive equipment with modest space requirements, without effluent production or any need for washing-off.

Against these advantages may be set the relative lack of flexibility inherent in transfer printing: no single transfer-printing method is universally applicable to a wide range of textile fibres. While a printer with a conventional rotary-screen printing set-up can



proceed to print cotton, polyester, blends and so forth without doing a great deal beyond changing the printing ink used, the transfer printer hoping to have the same flexibility would need to have available a range of equipment suited to the variety of systems that have to be used for different dyes and substrates using transfer technology. In addition factors such as stock costs, response time and so on do not always apply and unlike dyers, most printers are able to operate without steaming or washing by using pigment-printing methods. Thus a balance exists which not only permits but even requires the coexistence of direct and transfer printing. The relative importance of the two methods consequently varies with fluctuations of the market, fashion and fibre preference.

A great many methods of producing textile transfer prints have been described in the literature. Many of them exist only in patent specifications but several have been developed to production potential. They may be summarised most conveniently as below.

Sublimation transfer

This method depends on the use of a volatile dye in the printed design. When the paper is heated the dye is preferentially adsorbed from the vapour phase by the textile material with which the heated paper is held in contact. This is commercially the most important of the transfer-printing methods.

Melt transfer

This method has been used since the 19th century to transfer embroidery designs to fabric. The design is printed on paper using a waxy ink, and a hot iron applied to its reverse face presses the paper against the fabric. The ink melts on to the fabric in contact with it. This was the basis of the first commercially successful transfer process, known as Star printing, developed in Italy in the late 1940s. It is used in the so-called 'hot-split' transfer papers extensively used today in garment decoration.

Film release

This method is similar to melt transfer with the difference that the design is held in an ink layer which is transferred completely to the textile from a release paper using heat and pressure. Adhesion forces are developed between the film and the textile which are stronger than those between the film and the paper. The method has been



developed for the printing of both continuous web and garment panel units, but is used almost exclusively for the latter purpose. In commercial importance it is comparable with sublimation transfer printing.

Wet transfer

Water-soluble dyes are incorporated into a printing ink which is used to produce a design on paper. The design is transferred to a moistened textile using carefully regulated contact pressure. The dye transfers by diffusion through the aqueous medium. The method is not used to any significant extent at the present time.

These different methods are considered separately in this chapter since they introduce different scientific and technical factors, and their use is best discussed in the context of the rather different commercial environments.

3.2 SUBLIMATION TRANSFER

Commercial sublimation transfer printing can be traced back to 1929–30 when disperse dyes were under close investigation at British Celanese Ltd during one of those periods of intense creativity that mark the history of dyestuff and coloration research. The investigators at Celanese picked up an observation by Kartaschoff, made during the early development of disperse dyes, that cellulose acetate became coloured when heated in contact with the dye powders [1]. They prepared papers impregnated with aqueous dispersions of the dyes and dried them, and heated them in contact with a cellulose acetate fabric. The fabric became strongly dyed. This observation was developed into a patented process which differs little in principle from that which is the present basis of sublimation transfer printing, namely ‘a process of coloration in which a volatile dye applied to a paper transfer sheet is passed, with the dye layer in contact with the fabric to be coloured, between hot calender rolls’ [2].

But the only textile substrates available in the 1930s for sublimation transfer printing were the cellulose acetates, which were not very stable at the required process temperature. This limitation, combined with the poor heat fastness of the dyes that had been developed at that time, prevented further progress being made.

The appearance some 20 years later of poly(ethylene terephthalate) (polyester) fibres changed the situation and created the conditions for a revival of the early process. With the new fibres came new application methods, notably thermofixation [3], which involved padding fabrics with an aqueous dispersion of suitable disperse



dyes, drying and heating the fabric at temperatures near to the softening temperature of the polyester. It was soon recognised that thermofixation involved sublimation of the dyes and adsorption on to the fibre from the vapour phase. At the high temperatures involved diffusion into the polymer was sufficiently rapid for a practical process to be devised. Based on these developments, a re-examination of sublimation transfer printing was begun, notably by de Plasse of Filatures Prouvost Masurel. Based on this work patents were taken out to cover aspects of ink preparation for printing transfer papers and a new company, Sublistic SA, was formed to commercialise the system [4]. It is worth noting that the formation of Sublistic SA involved the collaboration of dye-manufacturing, paper-printing and textile interests since vital technical inputs were needed from all three industries.

The introduction of transfer papers by Sublistic SA, backed up by sophisticated design and marketing as well as the development of suitable transfer equipment, occurred at the start of the 'polyester boom' and, indeed, contributed to it. Thus the new technical development found unusually few impediments to commercial success. Not surprisingly, other producers found ways of evading the terms of the Sublistic patents and new collaborative ventures appeared around the world. By 1970 some 24 million metres of transfer papers had been produced. Three years later, production had risen to 300–400 million metres per annum, and approximately one-third of printed polyester was being printed by transfer [5]. At that time there were forecasts of annual production levels of 1–2 billion metres by the 1980s; these, however, can now be seen to have been very optimistic, failing to allow for market saturation, fabric preferences and fashion. The serious decline in the popularity of polyester and changes in the relative production costs of natural and synthetic fibres led to extensive contraction in the sublimation transfer print industry. The process itself remained important, however, because the factors favouring this approach to printing did not change. A recent survey, confined to the printing of continuous web, found that some 10% of printing is carried out by transfer [6], while another has noted a marked increase of transfer printing during 1990 [7].

One response of the industry to its problems has been to seek ways of using sublimation transfer for the printing of natural fibres, particularly cotton. These have had some success and will be considered separately.

In the production of sublimation transfer papers and prints, four factors must be considered:

- selection of the paper
- printing methods
- dyes and inks
- the mechanism of sublimation transfer
- producing transfer prints on both man-made fibres and natural fibres.



3.2.1 Selection of the paper

Normally the selection of a paper for printing is governed only by considerations which apply to printing alone: the printing process, the printing machine, the printing inks and the appearance of the final product. In producing a sublimation transfer printing paper these, apart from the last, remain of great importance but to them are added the factors of the transfer process itself and the behaviour of the inks during that process. These extra factors impose some special limitations on the types of paper that may be used [8].

Papers weighing from 35 to 115 g m⁻² have been used, depending on the printing method. Since the cost of the paper represents a significant proportion (25–40%) of the cost of the product (and, additionally, since unprinted paper is purchased by the tonne and sold by the metre), it is important to use as light a paper as is consistent with the other factors that have to be taken into account. The lighter-weight papers are used in high-speed gravure or flexographic printing, while the heavier papers are used in sheet-fed systems such as flat-screen or lithographic printing where the mechanical handling of light papers is difficult. Essentially a smooth printing surface is required on which a sharp image can be produced. The paper has to be dimensionally stable during the printing process in order to preserve register, and also during the transfer process in order to avoid image distortion. This means that a highly calendered paper based on a kraft pulp is generally favoured. The paper may contain fillers such as china clay or titanium dioxide to assist manufacture or printing. For some specialised applications the paper may also incorporate unusual ingredients such as thermoplastic resin [9]. A certain amount of care is needed in selecting additives as some may interact with the dyes in the ink, restricting transfer or even causing chemical degradation.

In order that sublimation transfer of the dyes to the fabric shall be as rapid and efficient as possible, it is generally desirable that the paper should exhibit good 'hold out' – that is, the liquid ink should not penetrate the paper surface more than is essential for the stability of the image. Excessive penetration will also lead to a loss of definition. Consequently the surface of the paper may be modified by the application of a size which allows the ink to wet the surface but penetrate it slowly. Unsize paper can present special problems when water-based inks are used, due to dimensional changes which occur due to water absorption and difficulties in drying fully between printing stations. On the other hand a considerable amount of transfer paper has been produced using spare capacity on regular rotary-screen textile-printing machines. Since such machines do not provide for drying between printing stations, printing is carried out 'wet-on-wet' using water-based inks. In these circumstances rapid absorption of water from the ink is desirable so that sufficient loading of the ink may be allowed. By controlling the pore size during manufacture of the paper and adding



rosins, waxes or synthetic sizes to modify water contact angles, water absorbency can be controlled in such cases to within close tolerances.

At the transfer stage the paper requires several additional characteristics:

- good release of dye vapour from the ink layer
- stability to heat
- low permeability to dye vapour
- good dimensional stability during transfer.

The release of dye vapour during transfer is dependent not only on the vapour pressure of the dye at the transfer temperature but also on the rate of diffusion of the vapour through the surface layers of the paper and the affinity of the dyes for the cellulosic substrate or the thickener, binder or other additive used in making the paper or the ink.

It is probable that the primary effect on the paper itself of heating it to the transfer temperature for the few seconds required is to remove water and thus tender it irreversibly. Some chemical degradation of the paper may also occur, especially if it has been left in an acid condition. Care must be taken to select a paper in which there are no reducing agents or other chemical residues which may attack the dyes. Paper tendering may occur even with a long-fibre paper of high initial tear strength, such as a kraft paper (made from softwood by alkaline chemical pulping), but by selecting the right paper-making conditions the loss of strength may be kept within practical bounds.

The permeability of the paper to the dye vapour is a vital factor. Where transfer printing is carried out at atmospheric pressure or when vacuum assistance is used, low permeability is an obvious advantage ensuring that the direction of dye migration is always towards the fabric. Hence achieving maximum 'hold out' is clearly important in minimising the distance dye vapour has to travel through the paper surface. On the other hand, when transfer is assisted by an induced air flow the paper support has to be permeable to the air and free from pinholes [10]. In all methods some dye inevitably penetrates the paper, but papers have been developed empirically which give a very high efficiency of transfer when used correctly.

The properties of the back or unprinted face of the paper are also important, since when papers are stacked or rolled for storage the front (printed) and back faces are in close contact and dye may therefore mark off. If papers contaminated in this way are easily permeable to the dye, diffusion can take place over time, leading to a ghost image on the face and defective transfer prints.

The loss of water during transfer can in some cases lead to a dimensional change. This can be sufficient to cause relative movement of fabric and paper during transfer, with consequent loss of clarity. The fabric itself may also show a dimensional change



with the same consequences and this is considered in discussing the production of sublimation transfer prints at a later stage.

3.2.2 Printing methods

Any of the commercial processes employed in the printing industry may be used for the production of sublimation transfer printing papers [11]. In practice web offset and letterpress printing are not used; production is effectively restricted to gravure, flexographic and rotary-screen printing for continuous web production, while flat-screen and lithographic printing are used for the production of transfer sheets.

Gravure printing

This method of printing uses solid metal rollers engraved with a design or wooden rollers carrying an engraved metal wrapper. Ink is delivered via a series of rollers to the engraved printing roller and excess ink is removed with a doctor blade, leaving ink only in the engraved areas. When the inked roller is brought into contact with paper using an applied pressure the ink is almost completely transferred to give a print. The amount of ink delivered, which controls the colour depth, is determined by the depth of the engraving. The efficiency of transfer of ink from roller to paper is sometimes enhanced by establishing an electrostatic potential across the interface, which ejects the ink from the roller. Using a series of rollers with varying depths of engraving and allowing successive inks to overprint and produce 'fall on' effects, very complex designs with a large tonal range can be produced with high definition and subtlety. Very high printing speeds can be achieved ($60\text{--}120\text{ m min}^{-1}$) but the paper must be dried in between print stations in order to avoid smudging or marking-off. In this respect the gravure printing of paper differs from that of textiles, in which the absorbency of the fabric allows wet-on-wet operation. The need for rapid drying when printing paper by gravure makes it necessary to operate with highly volatile solvents such as toluene or ethanol, and in many countries this is leading to increasing pressure from environmental protection agencies.

A commercial gravure printing machine has as many as ten print stations and is fitted with automatic registering devices of great efficiency. The capital investment is very considerable, and in addition a large stock of expensive print rollers has to be maintained. For a stock in trade of 50 designs perhaps 300 rollers will be required, each costing several hundred pounds. But apart from this important commercial factor, gravure printing of transfer paper has come under some competitive pressure from other methods since in order to avoid distortion of the print rollers a limit has to be imposed on the width of the paper to be printed, and this is generally less than the



widths of textile fabrics. Nevertheless, due to the very high quality of printing and the subtlety of shading in design which it makes possible, gravure printing of transfer papers remains of considerable importance.

Flexographic printing

Also a roller-printing method, flexographic printing has the advantage over gravure printing that it is less capital-intensive with regard to both machinery and stock design roller costs. Moreover, it uses water-based inks and is suitable for printing wide papers. On the other hand flexographic printing offers less sophistication in design, especially with regard to tone effects, although these are possible to some degree.

The flexographic print roller, also called the stereo, is covered with rubber or composition, and carries the design in relief. The design is cut out using standard techniques but in recent years laser cutting has introduced new high standards of precision which have led to great improvements in print quality. By laser cutting the raised portions of the stereo may be cut in such a way that tone effects, albeit somewhat coarse, can be produced. The printing ink is delivered to the stereo roller by an engraved metering roller to which ink is delivered from the print trough. Thus the raised portions of the roller are effectively gravure coated, and by controlling the depth of engraving the amount of ink supplied can itself be controlled.

The stereo rollers (normally there are six, sometimes eight) are arranged around a large drum carrying the paper. Since only the raised portions of the stereo come into contact with the paper there is no need for drying between print stations; as the paper is dried only once, there is no problem of dimensional change on drying and slower-drying solvents can be used. Relatively low printing pressures are needed, and this enables wider papers to be printed. If the paper is dried between stations fall-on effects can be produced, but this is unusual in the production of sublimation transfer papers.

Normally flexographic printing delivers relatively little ink to the paper, and for transfer printing paper production it is frequently necessary to apply heavier than usual ink loadings in order to achieve the required shade depth on the fabric. In practice this means that in the production of transfer paper by flexographic printing output is frequently slower than when gravure printing is used or when flexography is used for normal paper printing.

Rotary-screen printing

When rotary-screen printing became widely available in the textile industry, a demand naturally developed for it to be used also for the production of transfer paper, thus creating the possibility of 'in house' manufacture cutting out the commercial paper



printer. Rotary-screen printing also has many intrinsic attractions from the point of view of transfer paper production, such as relatively low capital cost and the capability of printing very wide widths. In addition, the ability of screen printing to deliver heavy ink loadings can be useful for the production of papers for transfer printing heavy fabrics or thick materials such as carpet tiles.

Production of transfer paper by rotary screen does not differ in principle from textile printing by the same means. Paper is less compressible and less absorbent than fabric, however, and careful control of conditions is very necessary. The paper used has to be more absorbent than that used for gravure or flexographic printing since it is necessary to operate wet-on-wet. It has to have the capability of draining the water from the ink layer, but must be only minimally penetrated by the essential ingredients (dyes and binder).

Lithographic printing

Lithography offers the potential of producing photographic quality reproduction. As its name suggests, it originally depended on the properties of particular kinds of stone, but modern lithography (also known as 'off-set' printing) is based on modifying the surface properties of coated metal plates. A zinc or aluminium printing plate is coated with a light-sensitive oleophilic (hydrophobic) material. When the plate is exposed to light through a photographic colour separation negative the exposed areas become 'cured' so that the film can be washed off in the unexposed areas. Thus the design becomes reproduced on the plate in a pattern of oleophilic and hydrophilic areas. When the plate is wetted with an aqueous (or substantially aqueous) 'fountain liquid' the contrast between the two areas becomes so marked that an oil-based ink applied to the plate adheres only in the oleophilic regions, allowing the design to be printed on to paper. Generally, but not always, lithographic printing is carried out using four colour process inks giving yellow, magenta, cyan and black. This enables a very broad shade gamut to be produced with great shading subtlety. Depth of shade is controlled by printing each colour in dots rather than as an even coating. All the dots have the same colour intensity, but their size and density is controlled so as to present the observer with an image made up of coloured dots and the white paper substrate showing in between. Thus the colour physics of white and colour blends applies, rather than that of mixtures. This has important repercussions for the production of sublimation transfer printing paper by lithography, because the dot sizes produced on the paper by printing are not those produced on the fabric by transfer due to the lateral diffusion of the dye. By adjusting the dot size in accordance with the sublimation characteristics of the dyes the situation can be controlled [12].

The amount of ink delivered to the paper by the plate is small; the ink layer in the



dots has a thickness of only 1–2 μm . The colour content of the inks has therefore to be of the order of 50%, leading to very high viscosity relative to the inks used in other systems of printing.

The inks are oil-based. Originally drying oils such as linseed oil were used so that the printed image was oxidatively cured on standing. Today the principle is much the same although synthetic products are used. Since the printed ink films (or dots) are very thin, the different colours are applied successively without intermediate curing or drying and high printing speeds are possible.

Although initiation costs (such as plate production and machine setting) are high, production is cheap and for longer print runs the process is very attractive. As a process lithographic printing is used to print both sheets and continuous web but as far as transfer paper production is concerned only the sheet-fed version is used.

Flat-screen printing

Although flat-bed textile screen-printing equipment can be used for the production of transfer paper in the same way as described above for rotary-screen printing, the use of flat screens is limited effectively to the production of transfer sheets in standard paper-printing machines. These are designed to print large sheets which are cut up later for the production of placement designs or logos for garments or garment panels. The machines print at higher speeds than textile machines (1000–2000 sheets per hour) but each colour has to be applied separately in a single pass. Dimensional changes occurring during the drying of the paper can make the maintenance of register very difficult so that dimensional stability is an important requirement in selecting a paper.

The machines are generally fed automatically and the devices used require a flat sheet with a clean edge. Additionally the paper has to be dried while being carried on a moving belt without being blown about. This means that sheet-fed transfer papers are fairly heavy, in practice at least 75 g m^{-2} and normally 100–110 g m^{-2} . The inks may be solvent- or water-based.

3.2.3 Dyes and inks

The essential ingredient for a sublimation transfer ink is of course the colouring matter, which must be volatile at the transfer temperature that is appropriate for the textile being printed. This means that the molecules of the dyes used must be relatively small and contain as few as possible ionic substituents, which would limit or inhibit volatilisation. The dyes used are consequently chosen from the disperse dye class; not all dyes possessing appropriate volatility are suitable, however, since other considerations are important. Solvents are varied: a volatile liquid such as toluene in a



gravure printing ink, an ethanol/water mixture in a flexographic ink, a drying oil for lithography or a water-based system for screen printing. The degree of dispersion must be appropriate for their use with gravure rollers in gravure or flexographic printing. Normally disperse dyes are supplied as an aqueous paste or a powder containing dispersing agents and other diluents, which are frequently found to be unsuitable for incorporation into an ink. Consequently the dyes used for sublimation inks are obtained at the press-cake stage before other diluents are added and are selected to have very low solubility in the ink solvents and to be free from any tendency to crystallisation on standing.

The ink will also contain a binding agent which holds the dye on the paper. This is chosen to give the ink the right rheological properties for printing without inhibiting migration of the dye to the fabric during transfer. In water-based inks the binders are often alkylcelluloses, while in solvent-based inks poly(vinyl acetate) or acrylic polymers may be used [13]. An interesting variant is the use of a hydrophilic binder such as hydroxymethylcellulose in an emulsion ink based on water and toluene.

Inks are prepared by standard milling methods to reduce particle size to a suitable level. Because of the relationship between particle size and solubility, overmilling yielding very small particle sizes can be counter-productive, as it may lead to flocculation or subsequent particle growth.

Structural features of suitable dyes

Due to the limitations of the market, even at the height of the popularity of sublimation transfer printing there was little incentive for dye manufacturers to synthesise dyes specifically for transfer print applications. Instead, their approach has been largely empirical, based on selection from existing ranges of disperse and solvent dyes, and batches of selected dyes have been taken out of the regular manufacturing programme to be specially finished for ink manufacture.

Most of the dyes used for transfer printing are based on monoazo or aminoanthraquinonoid chromophores. It has been claimed that particular nitrodiphenylamines and disazo [14] and cyanovinyl [15] dyes are sufficiently volatile, but these claims have not been accompanied by any parallel commercial activity. It has been established empirically that suitable dyes should preferably possess an r.m.m. of no more than 350, with a molecule containing a minimum number of polar auxochromes such as NO_2 , CN , SO_2R , NH_2 or NHR , and no ionic groups such as SO_3H or COOH . These broad considerations mean that only selected disperse dyes can be used for sublimation transfer printing and only those fabrics which have sufficient affinity for these dyes (polyester, polyamide, triacetate or acrylics) can be so printed. Since the cohesive forces in the solid disperse dye are of the same kind as those bonding the dye



molecule to the fibre, easy volatilisation will be related generally to the heat fastness of the transferred dye. This relation is, of course, conditioned by the relative ease of escape of a dye molecule from a dye crystal and the difficulty of such a molecule diffusing through the polymer matrix.

There are, however, two structural features that can enhance the volatility of the dye without reducing the heat fastness. First, the presence of bulky substituent groups can prevent close packing of the dye molecules in the solid and limit the strength of intermolecular bonding without having much effect on dye-fibre bonding; structure 3.1 is an example of such a molecule. This is shown by a lower latent heat of sublimation than would be expected for a dye of higher r.m.m. and a greater than expected affinity for the substrate.

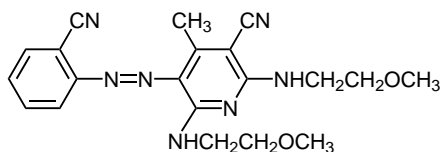

3.1

Secondly, when polar groups capable of hydrogen bonding with the polymer substrate, such as NH_2 , OH or NHR , are present as substituents in such a way that they become involved in intra- rather than inter-molecular bonding, they do not have as great an effect in reducing volatility but can still contribute to dye-fibre bonding. The effect is well illustrated by the data for two dyes (3.2, 3.3). At 200 °C the vapour pressure of compound 3.2, which is internally hydrogen-bonded, is 157 Pa (1.18 mmHg); compound 3.3, which has the same molecular mass but is not internally hydrogen-bonded, has a vapour pressure at 200 °C of only about 0.005 Pa (3.71×10^{-5} mmHg) [16].

Both polyester and cellulose acetate can be printed satisfactorily and with good fastness by sublimation transfer printing. Polyamide fibres can be readily printed, but the prints do not have good fastness to washing or heat. Acrylic fibres can also be

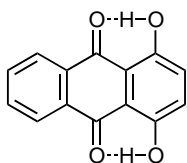

3.2

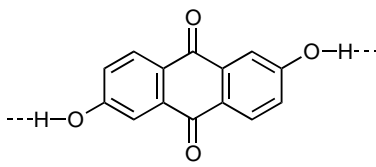

3.3

printed, but the prints lack intensity. To achieve better results on these substrates two novel approaches have been explored. The wet fastness of sublimation transfer prints on nylon is improved if a suitable reactive group, such as chloroacetyl amino or dichlorotriazinyl amino, is introduced into the dye molecule, thus increasing the extent of dye–fibre reaction [17]. The effect is real but not large. Much more effective is the incorporation into the molecule of azide groups, such as SO_2N_3 [18,19], which react by the generation of nitrene species inserted into the polymer on heating. This can give as much as 77% dye fixation – much better than the levels of fixation of other reactive dyes under these conditions [10]. There has, however, been no commercial exploitation of this system.

Attempts have been made to use modified basic dyes to provide a sublimation transfer system for printing acrylic fibres. The carbinol form of some basic triarylmethane dyes (for example, structure 3.4) can be volatilised from alkaline ink layers [20]. The dye interacts with sulphonate groups in the fibre to regenerate the coloured ionic form of the dye (Scheme 3.1).

The system is more efficient if the cation is an ammonium ion, as the ammonium hydroxide liberated can escape from the system. Ensuring that the transfer paper remains alkaline during storage is in this case difficult, however. Another approach uses basic dyes that can be deprotonated to yield a neutral volatile form. The dye is reprotonated after transfer [21,22]. The volatile species is usually an amine, which may be *N*-substituted. The basic dyes when applied by sublimation transfer using either of these options have lower wash and light fastness than when applied normally. This disadvantage, combined with the commercial difficulty of catering for the restricted market available for transfer printing acrylic materials, has resulted in a very limited exploitation of these methods. It is worthy of note that current interest in producing muted designs on garment panels made of blends consisting substantially of acrylic fibres is fully satisfied by the use of regular sublimation papers.

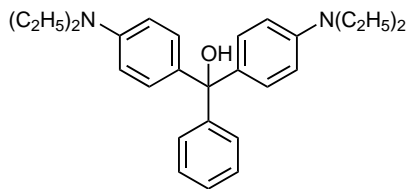

3.4

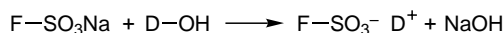

Scheme 3.1

Compatibility during sublimation transfer

Because of the multiplicity of factors involved in transfer printing (diffusion through the ink binder medium, sublimation, affinity for and diffusion through polymer matrix of the fibre) the shades produced under different production conditions are apt to vary markedly. The most important variable factor is temperature. Temperature variations occur not only between batches but also across the width of wide fabrics. With thick fabrics, and especially those with pile, temperature variations through the depth of the material can also be expected. Consequently it is important to select dye mixtures in which the components all behave in much the same way so that any variation that may occur will be limited to depth rather than differences in hue.

It has become customary to classify disperse dyes for sublimation transfer on the basis of empirical tests which are considered to reflect all the factors in a practical situation. In the UK several companies have adopted a classification of the dyes according to an A–D scale of decreasing transfer rate, and it is recommended that dye mixtures should be put together from dyes of the same group. In general, however, dyes of Group A are so volatile that prints have poor fastness, particularly to heat, and frequently poor definition; at the other end of the scale, dyes from Group D are difficult to transfer. Hence dyes are selected almost invariably from Groups B and C. Some care has to be exercised even within this narrow band, however. Generally speaking, compatibility and reproducibility of shade is quite easy with lightweight fabrics, which can be transfer printed with short treatment times; as the fabric becomes more difficult to penetrate and transfer times need to be longer, residual differences between the dyes in the mixture begin to show up. Vacuum-assisted transfer (see section 3.2.5) can be of some assistance in this connection. With pile fabrics variable penetration of the material has led to the successful use of dye mixtures that include dyes of both high and low volatility [23,24]. The more volatile dye migrates into the pile of the fabric while the other remains at the surface.

Another somewhat looser system of classification is the categorisation of dyes as ‘high, medium or low energy’ [25]. This uses a test in which is measured the temperature required for 90% colour development during transfer in a fixed (30 s) transfer time. The problem with this approach is that it does not allow for the variations in transfer time which occur in practice. If the dwell time is increased from the standard 30 s of the test, then obviously the temperature needed to produce 90% development will be reduced. But the change differs markedly from one dye to another and consequently the ‘energy’ system should be used with caution.

3.2.4 The mechanism of sublimation transfer

The physical chemistry of disperse dye adsorption from the vapour phase has been



considered in detail elsewhere [26]. In this chapter discussion will be confined to the particular conditions of transfer printing polyester and other man-made fibres. In conditions where polyester fibres are in contact with dye vapour the distribution of the dye at equilibrium is governed by a partition isotherm, in which the partition coefficient K is defined by Eqn 3.1:

$$K = \frac{C_f}{C_v} \quad 3.1$$

where C_f is the dye concentration in the fibre phase and C_v is the concentration in the vapour. It is conventional to assume that an instantaneous equilibrium governed by the isotherm is established between the vapour and the surface, so that the kinetics of achievement of the ultimate equilibrium are governed by the rate of diffusion of dye from the bulk of the vapour to the surface and by its rate of diffusion from the surface of the fibre into the fibre mass. Another consequence is that when the vapour is saturated then so is the fibre surface, and further adsorption can only occur as dye diffuses into the fibre to create free sites. Assuming that the dye vapour possesses ideal behaviour, the concentration in the saturated vapour is given by Eqn 3.2:

$$C_v = \frac{pM}{RT} \quad 3.2$$

where p is the saturation vapour pressure of the dye, M the molecular mass of the dye, R the gas constant and T the temperature. The data in Table 3.1 is based on Eqn 3.2. The values relate to an operating temperature of 200 °C (a typical transfer temperature) by extrapolation.

Although relatively few transfer printing dyes have a known vapour pressure, the data in the fourth column of Table 3.1 is sufficient to show that under transfer printing conditions the dyes are present initially in the vapour at a concentration of 10^{-3} to 10^{-5} g l⁻¹. Since cellulose acetate [33] and polyester [29] can adsorb approximately 10% of their own mass of dye, the value of K is of the order of 10^5 to 10^6 , which is much higher than that found in aqueous systems. This phenomenon relates to competition, possibly allosteric in nature, between dye and water for sites on the fibre, and has been discussed in detail elsewhere [26]. One important practical consequence is that fibres can be 'overdyed' during transfer printing if there is too much dye in the ink layer. Fibres overdyed in this way will slowly desorb dye on exposure to normal water-bearing atmospheres and will develop poor fastness to rubbing and washing.

The effect of the high distribution coefficient is that fibre saturation will develop at or just beneath the fibre surface as soon as the fibre/transfer paper interface reaches the



Table 3.1 Vapour pressures and concentrations of transfer printing dyes at 200 °C

Dye	R.m.m.	Saturated vapour pressure /Pa	Concn /g l ⁻¹	Ref.
CI Disperse Blue 14	266	8.2	5.56×10^{-4}	28
CI Disperse Blue 56	350	0.2	1.72×10^{-5}	29
CI Disperse Orange 3	242	21	1.29×10^{-3}	30
CI Disperse Red 9	237	136	8.23×10^{-3}	31
CI Disperse Red 15	239	48	2.94×10^{-3}	32
CI Disperse Red 60	331	6.4	5.38×10^{-4}	29
CI Disperse Violet 1	238	2.7	1.67×10^{-4}	28
CI Disperse Yellow 3	269	8.4	5.76×10^{-4}	27
CI Disperse Yellow 8	261	59	3.96×10^{-3}	28
CI Disperse Yellow 54	288	0.9	6.16×10^{-5}	29

operational temperature. The effect has been described in detail by Fenoglio and Gorondy [34] who devised the model shown in Figure 3.1.

This consists of a fabric F in contact with an ink layer I on a paper substrate P. The fibre and ink phases are visualised as planar slabs as shown. A gap G separates the fibre and ink layers, reflecting the fact that even under pressure the area of contact between the paper and the fabric surface will be small and most of the dye molecules will have to travel across an air space. The dimensions of the gap will depend on the applied pressure, the nature of the paper, the filament diameter of the fibres in the fabric surface and the fabric construction. Clearly the Fenoglio and Gorondy model is a gross simplification of the true transfer-printing situation but may be regarded as applying in the sense of a differential. Prior to heating (Figure 3.1a) the dye is contained in the ink layer. When the paper is heated on the reverse side (Figure 3.1b) dye sublimates into the gap and transfers by diffusion down a concentration gradient to the fibre surface. Initially there is also a temperature gradient across the gap, which may for a short time lead to dye condensing on the fibre surface, but after a brief delay a uniform steady-state system will be established which can be considered in detail. The length of this delay will depend on the size of the gap as well as on the thermal properties of the paper and the fibre, but it may be assumed to be short relative to the full transfer time. At the steady-state transfer temperature dye will diffuse from the fibre surface inwards down a second concentration gradient within the fibre.

In order that diffusion within the fibre may be as rapid as possible, the operating transfer temperature needs to be such that segmental motion in the polymer is rapid. Provided the flux of dye vapour from the paper continues, adsorption and diffusion will



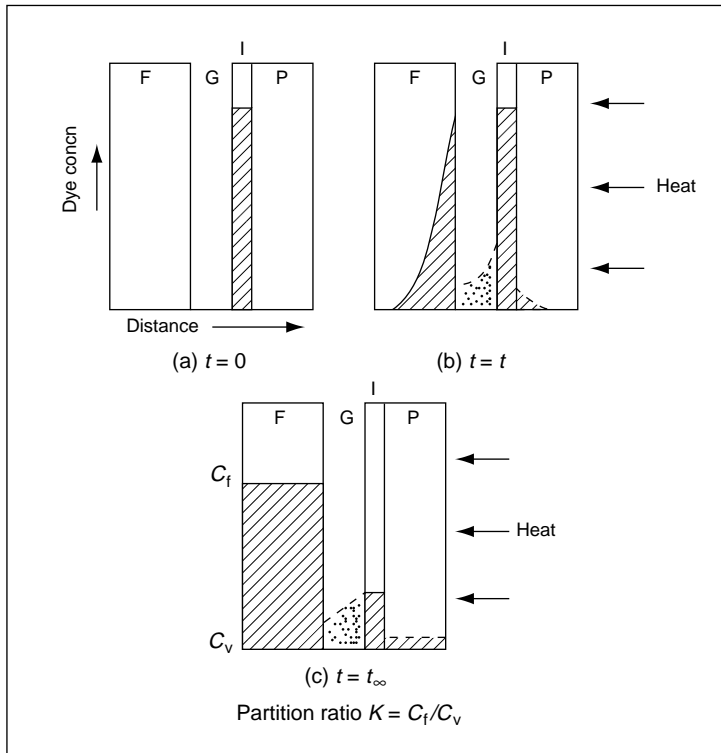

Figure 3.1 Model system describing vapour transfer-printing mechanism

proceed until a thermodynamic equilibrium is established between the three phases F, G and I as shown in Figure 3.1c. In a practical system the distribution of the dye will be strongly in favour of the fibre phase; a little dye will be retained by the paper phase, however, due to the small affinity of the dye for the paper surface and the ink binder as well as a degree of back-diffusion into the paper during transfer. Naturally paper and binders are selected to keep this effect to a minimum.

There are thus four potential rate-determining steps in the situation:

- diffusion from the ink layer into the vapour
- diffusion across the gap between paper and fabric
- adsorption at the fibre surface
- diffusion into the fibre.

Initially the first of these will predominate, but once the steady state has been established it is the slowest process that will control the situation. Generally it may be assumed that adsorption at the fibre surface will always be rapid, provided the surface is

not saturated, so that it is the three diffusion processes and the factors affecting them which must be considered.

The production of a transfer-printing paper requires the dye to be dispersed or dissolved in a printable medium containing a binder that will hold the dye on the paper until it is used in the transfer process. When the paper is heated in contact with the fabric, the escape of the dye from the binder will depend on its affinity for the binder and its rate of diffusion through the binder layer. Thus selection of the binder material involves considerations beyond those normally involved in formulating a printing ink. Binders and associated solvents have been selected largely on empirical data, and relatively little has been published comparing different materials. However, the wide differences that can arise have been illustrated by Bosnakyan's work on the rate of transfer of the disperse dye Sublaprint Blue 70032 (LBH) from ink layers of a fixed thickness formed using different binders at different dye concentrations on metal foil [35]. (Foil was used to ensure that no penetration of the support was possible and that the transfer temperature was achieved very rapidly.) The results are illustrated in Figure 3.2.

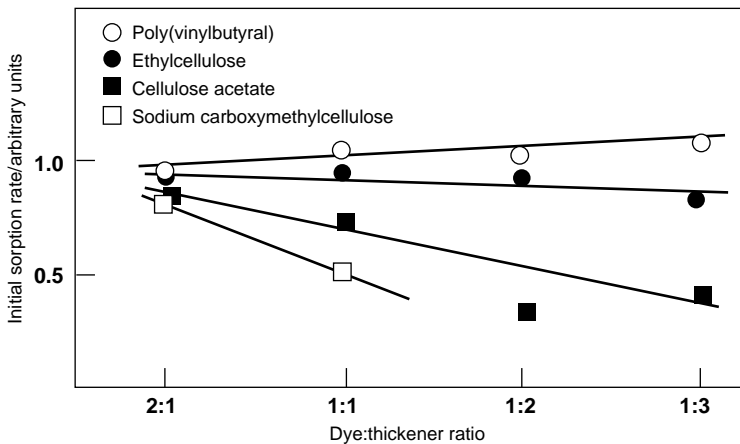

Figure 3.2 Changes in initial sorption rates at different dye:thickener ratios for Sublaprint Blue 70032 (LBH) at 200 °C

The marked differences that exist between binders are evident. At high dye:binder ratios the different binders behave similarly but as the ratio falls the affinity of the dye for the binder and its permeability become increasingly important. Poly(vinylbutyral) and ethylcellulose clearly offer greater flexibility than cellulose acetate or sodium carboxymethylcellulose. Ethylcellulose is generally favoured because inks that incorporate it have good printing properties and are easy to make. A new factor has

been introduced by the adoption of wet-on-wet rotary-screen production of transfer papers using fairly absorbent paper to allow sequential printing without intermediate drying. Inevitably this gives a rather higher degree of paper penetration than, say, the use of solvent-based inks printed by gravure on a highly compressed paper. The choice of a binder in these circumstances involves consideration of the paper construction and the differential diffusion of water and dispersed binder from the wet ink, in addition to the factors considered already.

Once the dye has escaped from the paper surface it must migrate across the gap G . The Fenoglio and Gorondy model relates to the penetration of dye into a single fibre from a paper surface where the gap G is easily defined. With a real fabric consisting of an assemblage of fibres the magnitude of the gap will vary considerably. Fibres near to the paper will compete with fibres further away. Thus the rate of penetration of the fabric will depend not only on the rate at which a high surface concentration can be achieved but also on the ease with which molecules move within the spaces between individual filaments [36]. This is governed by the collisions between dye molecules and any others present, such as those from the ambient atmosphere, and is related to the average distance or mean free path λ_d . When only dye molecules are present (that is, in the absence of air), λ_d is given by Eqn 3.3:

$$\lambda_d = \frac{1}{\pi n \sigma_d^2 \sqrt{2}} \quad 3.3$$

where n is the number of dye molecules per unit volume and σ_d is the closest distance between centres of approach when the molecules collide.

Typical values of n can be obtained from Table 3.1. For example, 1 mol CI Disperse Yellow 3 contains 6.023×10^{23} molecules (i.e. Avogadro's number) and weighs 269 g. At 200 °C the saturated dye vapour concentration is $5.76 \times 10^{-4} \text{ g l}^{-1}$. Thus for a unit volume of 1.0 ml n is given by Eqn 3.4:

$$\begin{aligned} n &= \frac{6.023 \times 10^{23}}{269} \times \frac{5.76 \times 10^{-4}}{10^3} \\ &= 1.29 \times 10^{15} \end{aligned} \quad 3.4$$

Substituting this value for n in Eqn 3.3, and using the approximate dimension of $1.5 \times 10^{-7} \text{ cm}$ (based on the length of the CI Disperse Yellow 3 molecule) for σ_d , gives a value of $7.8 \times 10^{-3} \text{ cm}$ for λ_d .

In the course of transfer printing, however, the vapour contains other molecules



besides those of the dye. The presence of air, at pressures normally atmospheric but sometimes less, will supply other molecules which interfere with the movement of the dye molecules. Eqn 3.3 can be adjusted to allow for the presence of another kind of molecule as shown in Eqn 3.5, which gives a value λ_{da} for the mean free path of the dye molecules in the presence of another kind of molecule a:

$$\lambda_{da} = \frac{4V}{[\pi n_a (\sigma_d + \sigma_a)^2] \sqrt{[(M_d + M_a)M_a]}} \tag{3.5}$$

where the unit volume V may be taken as 1 ml as before. The subscripts d and a refer to the dye and the other molecule respectively, and M is the r.m.m. For simplicity the atmosphere may be regarded as consisting of only one kind of molecule having characteristics somewhere between those of oxygen and nitrogen, so that Eqn 3.5 can be used for the dye-in-air situation. One important effect of a large excess of air molecules is that the mean free path of the dye molecules becomes virtually independent of temperature. Jones has applied Eqn 3.5 to the situation when the ambient pressure is varied at a constant temperature to produce the relationship shown in Figure 3.3 [37].

Figure 3.3 shows calculated values for three dyes of distinctly different r.m.m. It can be seen that it is only at low atmospheric pressures that this parameter is significant. At pressures above, say, 10 kPa the influence of the air swamps any effects due to variations in the dye molecules.

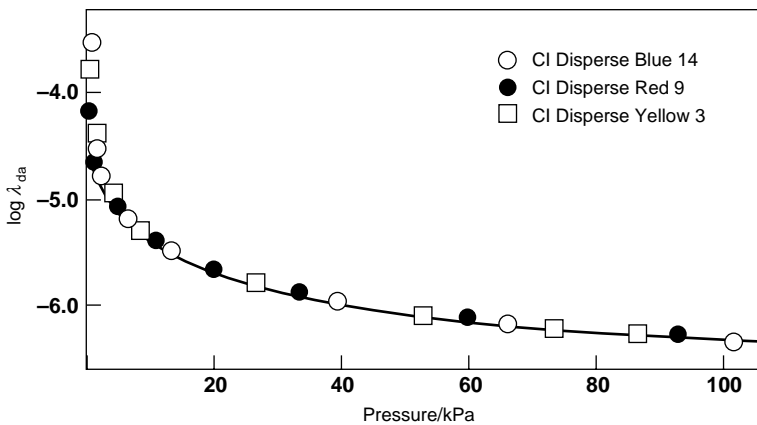

Figure 3.3 Changes in λ_{da} with ambient air pressure at 160 °C

Figure 3.3 shows the logarithm of the mean free path. Calculation of actual values shows that the ratio of the mean free paths at 3.3 kPa (25 mmHg) and at 101 kPa (760 mmHg) is 2.37×10^{14} . This has a very powerful effect in a practical situation, as has been confirmed by Dawson, who has measured the penetration of different dyes into thick carpet panels during transfer printing with four dyes of different volatility [38]. The results are shown in Table 3.2. The letters A to D in Table 3.2 relate to the volatility scale already mentioned and indicate the different dye properties exemplified. Dawson's results show that penetration is approximately doubled when the ambient pressure is reduced by two-thirds.

Table 3.2 Effect of ambient pressure on dye penetration during transfer^a

Dye	Dye class ^b	Pile penetration at different ambient pressures (in kPa)/%					Transfer/%
		100	66	50	33	3	
CI Disperse Red 15	A	30	35	50	70	100	83–92
CI Disperse Orange 25	B	15	25	45	60	85	73–87
CI Disperse Violet 33	C	5	15	35	40	50	53–55
CI Disperse Blue 122	D	5	5	10	15	25	25

a Transfer conditions: 45 s at 210 °C

b See text for explanation

An alternative to reducing the ambient pressure in order to increase the mean free path is to create conditions which impose a directional constraint on the molecular movement. Normally the sum of the free mean path motions is zero, but if the conditions are arranged so that the mean free paths become additive in a particular direction (by compelling the ambient molecules to move in the same direction away from the transfer paper towards the fabric), then collisions between dye and air molecules will tend to assist rather than impede migration in the desired direction. The effect of a hot (220 °C) air stream through a permeable transfer paper on dye diffusion through a multilayer polyester assembly during a 20 s period has been reported and is shown in Figure 3.4 [10,39].

The rate of air flow is closely related to the magnitude of the pressure difference across the paper/fabric composite. At low values there is little effect in the particular system studied, but as the difference is increased to 29.3 kPa (220 mmHg) the dye becomes fairly evenly distributed through as many as 16 layers of fabric. From the

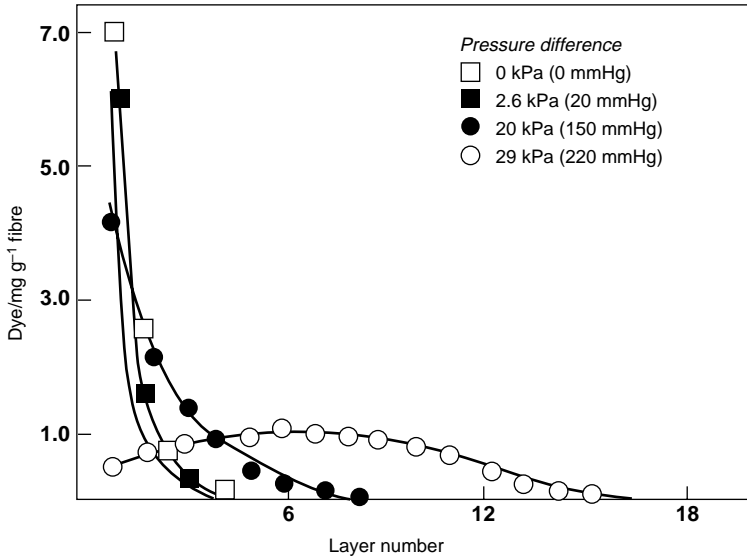

Figure 3.4 Distribution of CI Disperse Yellow 3 with continuous air flow

earlier discussion of the effect of the ambient pressure on the mean free path it is clear that the pressure difference of 29.3 kPa was needed in the particular situation studied to impose a dominant direction on the air molecules and is analogous to stirring a dyebath.

3.2.5 Producing transfer prints

Three considerations are paramount in establishing methods of production of transfer prints by sublimation. First, conditions have to be established that will lead to the rapid sublimation of the dyes and their diffusion into the fibres. Secondly, the gap between the paper and the fabric to be printed has to be minimised. Thirdly, the process must result in a fabric with substantially unchanged textile properties.

Clearly, the first of these requirements is met by using as high a temperature as possible, subject to not exceeding a level at which the fabric would be liable to be damaged or distorted. A similar compromise is involved in selecting conditions which achieve close contact between fabric and paper. Contact is maximised by applying a pressure to the fabric/paper composite, but fabrics will show deformation when compressed while being heated, especially at higher temperatures. Thus machinery designed for the production of sublimation transfer prints has to operate over a range of conditions which is determined by the properties of the fabrics to be printed and of the transfer papers themselves.

Machines for man-made fibre fabrics

Sublimation transfer printing was introduced initially for polyester fabrics, which soften in the region of 210–220 °C. Depending to some extent on the fabric structure, they are easily heat-deformed under pressure as the softening point is approached, and this can result in the fabric becoming glazed. In serious cases some spot welding may occur between fibres, leading to stiffening of the fabric. Nylon 6.6 fabrics behave similarly. Transfer printing of both nylon 6.6 and polyester fabrics can, however, be perfectly satisfactory in the temperature range 190–210 °C. Nylon 6 and acrylic fabrics must be handled at lower temperatures and are thus in general less suitable for the process.

Machines for producing sublimation transfer prints take many forms depending on the way in which the textiles are presented, whether as continuous webs, garments, garment panels, ribbons or tapes, hosiery and even caps. Apart from vacuum-assisted transfer, however, today's machines are little changed in principle from those developed originally for the process. The pressure bringing the paper into contact with the fabric is exerted either by a blanket under tension (in the case of continuous-web machines) or a hydraulically operated hotplate (in the case of unit printing of, say, garments).

Continuous-web transfer machines were developed from a type of machine common in the textile industry for preshrinking and setting, in which the fabric is passed around a heated drum under a continuous blanket. A typical arrangement is shown in Figure 3.5.

The size of the heated drum in the centre of Figure 3.5 determines the production rate of the machine. Thus a drum of 2 m diameter with a feeding system designed to

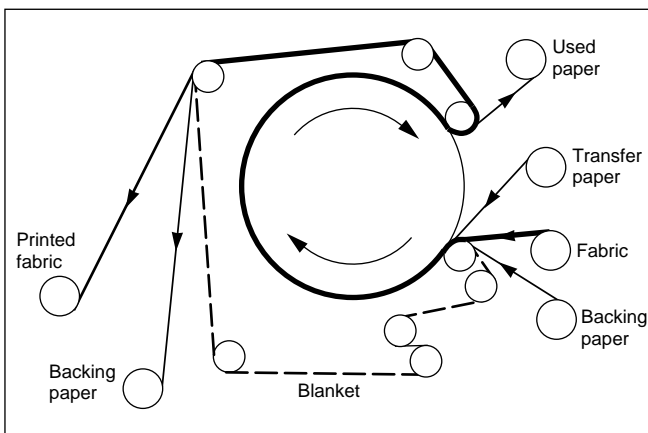

Figure 3.5 Continuous transfer printing

cover 80% of the surface will allow production of 900 m h^{-1} with a 20 s contact time. Production rates as high as 1300 m h^{-1} have been claimed in such machines with either larger drums or shorter contact times. The machine is operated with the reverse side of the transfer paper in contact with the cylinder and the face of the fabric against the printed side of the paper. The paper may be slightly wider than the fabric and a backing strip of paper is fed in to prevent dye being transferred to the continuous blanket. The blanket has to be made of material that can withstand temperatures in the region of $200 \text{ }^\circ\text{C}$ for long periods, and Nomex fabric is commonly used. This is made from an aromatic polyamide, poly(1,3-phenyleneisophthalamide), which because of the high cohesive forces developed from the aromatic system in the polymeric chain has a glass transition temperature of $275 \text{ }^\circ\text{C}$ and a softening temperature above $350 \text{ }^\circ\text{C}$ [40]. It is an expensive material but very suitable for sublimation transfer printing. The pressure between paper and fabric is controlled by adjusting the tension on the blanket. The effective pressure is not high (ca. $1.4\text{--}2.1 \times 10^3 \text{ kg m}^{-2}$) and even so at the upper limits of operating temperature glazing of fabrics may be observed. Since the applied pressures are low there are no major difficulties in the way of devising machines for printing wide fabrics up to 3.5 m.

It is essential to have a uniform temperature across the width of the transfer machine in order to have a constant rate of transfer and uniform colour. Special measures are normally required to achieve this. In machines by Hunt and Moscrop and by Kannegiesser the cylinder comprises a hollow shell containing a heat-transfer liquid; a biphenyl/diphenyl ether mixture is often used. The shell is only partially filled and the remaining space is evacuated before the system is sealed. The liquid is heated electrically and the vapour from the boiling liquid condenses on the internal surfaces to supply heat to the drum. Natural equalisation of the internal pressure ensures uniform heating and, providing the machine is sited sensibly so that there is no accidentally uneven cooling, uniform transfer temperatures are maintained. Other methods of heating, including the use of oil, gas and electricity, have been used with appropriately designed arrangements. A typical continuous-web transfer print calender is shown in Figure 3.6.

Transfer machines for garments and garment panels have been developed on very similar lines to conventional presses. A typical arrangement is shown in Figure 3.7.

In this version the paper is laid on the garment or garment panel on the continuous belt. This is then moved under the heated plate B by a drive operated by a foot pedal switch. The heated plate automatically lowers on to the paper/fabric composite and is held there for a preset time and at a preset pressure. The plate then lifts and the belt moves forward to allow the paper to be removed from the printed article, which is added to a stack. Meanwhile a fresh garment or panel is arranged for the next print.

An alternative arrangement is to have a moving flat bed which moves in and out





Figure 3.6 Rollingstatic MVZ 986, 3200 mm working width transfer-printing machine (Lemaire)

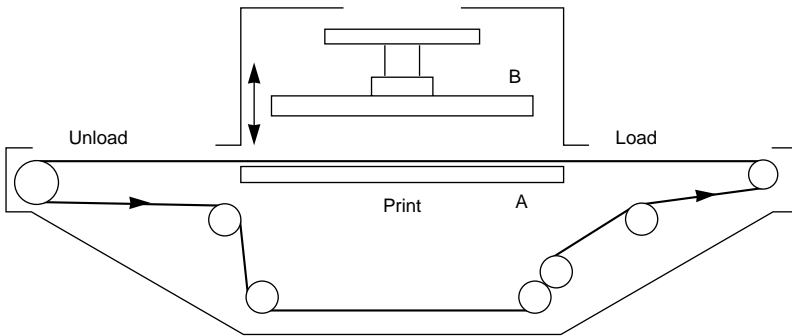

Figure 3.7 Flat-bed press (Kannegiesser)

from the plate. This allows loading and unloading to be carried out on both sides of the heated zone, giving higher productivity. There are several variations on this arrangement, designed to print caps, hosiery and other preformed articles. One variant, which is used for printing such garments as T-shirts and sweaters, is fitted with a continuous feed for the transfer paper. The unsewn garment is laid out with front, back and sleeves in a cruciform arrangement on the movable belt and is carried into the plate zone. The plate is lowered, bringing the paper into contact with the garment to produce an overall print. The plate then lifts and the garment is carried forward for removal, while at the same time the paper is advanced for the next print. When the garment is sewn together the print pattern extends over its whole surface.

Both continuous and unit printing machines have been redesigned to provide vacuum-assisted transfer. This is less easy with continuously operated units, but

nevertheless reliable and successful units are available. Vacuum assistance may take two forms. Either a pressure differential may be set up within the machine so as to promote a flow of hot air which assists the migration of the dye molecules, or the machine may be designed to produce a reduced pressure in the dye transfer zone.

By using a perforated hollow drum or plate and establishing a pressure differential, air can be made to flow through the system. The air flow holds the fabric in contact with the drum, and the paper is held in place without the need for a blanket. Although there may be some benefit in this arrangement in having the drum or plate heated, it is much more effective to have the heat supplied to the reverse side of the paper as in the conventional transfer machine. In a flat-bed machine this is easily arranged by using a perforated hotplate, while in a continuous machine external heating equipment such as infrared heaters gives the best results. One big advantage from this kind of arrangement in continuous-web printing, apart from more rapid transfer in certain difficult cases, is the absence of compression and consequent glazing of the fabric.

It is clearly much simpler mechanically to design a discontinuous low-pressure transfer machine, and several such machines are available. They operate in much the same manner as a flat-bed transfer machine, with the provision of a sealing system and a pump to evacuate the transfer zone rapidly. Such machines are useful for difficult fabrics such as Lycra stretch fabric for swimwear, which will not stand severe transfer conditions and yet requires to be printed with above-average penetration because it is naturally stretched in wear and stitch marks at the seams are unsightly. This type of machine is also of value in transfer printing carpet tiles, which must be printed without crushing while requiring good penetration down the pile or into the felt.

The difficulty with continuous vacuum transfer machines is in establishing a reliable seal with a continuous feed of fabric and paper. One solution is, in effect, to wrap the transfer drum in an evacuable skin. This approach has been used by Kleinfewers in a system in which the fabric and paper are held in contact with the heated cylinder surface by a perforated flexible metal band in place of the conventional blanket (Figure 3.8). On the outside surrounding 78% of the circumference is a continuously maintained vacuum chamber with the entrance and exit seal-operated. A major advantage of this arrangement is that the vacuum enables transfer to be achieved more quickly, even when operating at the 10.7 kPa (80 mmHg) pressures which can be used, so that the drum diameter can be reduced from the normal 2 m. This makes a system of this kind easier to construct. Production rates of 1800 m h⁻¹ have been claimed.

A more direct solution to the problem has been implemented in the Stork vacuum transfer system, which encloses the entire feeding and heating system inside a vacuum chamber (Figure 3.9).



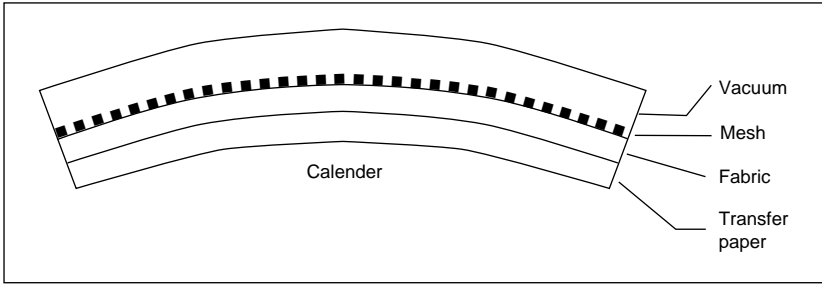

Figure 3.8 Continuous transfer printing under vacuum conditions (Kleinewefers DSV 1200 machine)

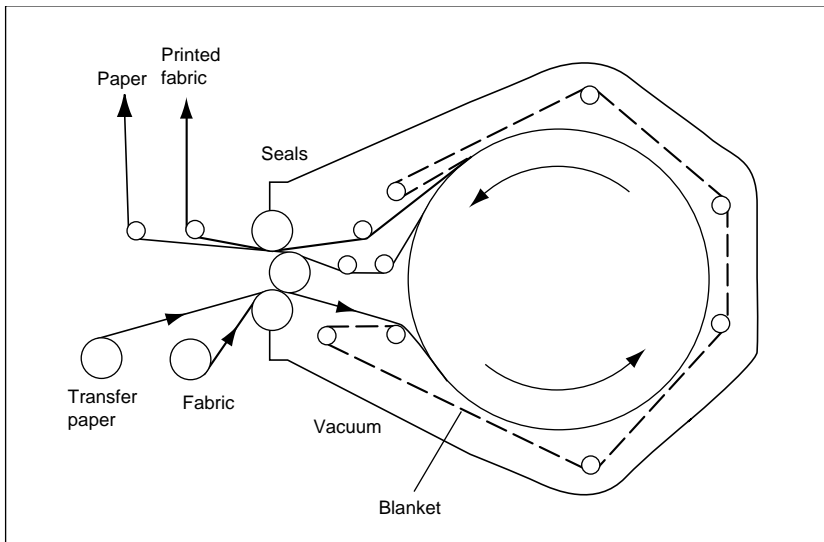

Figure 3.9 Flow diagram of vacuum transfer printer (Stork TC451 machine)

Vacuum transfer machines are particularly useful for heat-sensitive fabrics such as acrylic materials, since the transfer temperature may be reduced by as much as 40 degC. Alternatively dyes that sublime less readily can be transferred, with corresponding benefits in heat fastness.

3.2.6 Sublimation transfer on natural fibres

It is possible to use sublimation transfer papers to print fabrics made from blends of polyester or polyamide fibres with cellulosic fibres such as cotton or viscose. The dyes

will transfer to only a slight degree to the cellulosic component, although it is advisable in such cases to check the fastness achieved since some sublimable disperse dyes can stain cellulosic materials to a significant degree but with poor fastness. Since the cellulosic component is only weakly coloured, however, the quality of the result depends on its proportion in the blend, the extent to which the fabric structure presents it to the view, and the depth of shade to which the polyester or polyamide component is printed. At higher print strengths the prints have a somewhat milky appearance, due to the visual contribution of the weakly dyed cellulosic component. Consequently there has been for many years great interest in the possibility of using sublimation transfer papers to print cellulosic or substantially cellulosic materials, in addition to the general interest in developing transfer print systems for such fibres in competition with regular printing.

Two approaches to the problem have been explored commercially. One is to modify the cotton chemically to make it receptive of disperse dyes without significantly changing its textile behaviour, and some systems have been developed which exploit this to a limited degree. An alternative is to exploit the affinity of many sublimable disperse dyes for certain durable aminoplast resin finishes, and to treat the cotton appropriately before printing.

Cellulose acetate was the substrate in the first explorations of sublimation transfer printing [2], and this has been the starting point of many of the studies of chemical modifications of cellulose which have been undertaken with the aim of producing a cotton that is printable with sublimation transfer dyes. But there are limits to the degree of chemical modification that is permissible before the cotton loses the properties which make it the most important textile fibre. Thus alkylation using acetic, propionic or butyric acid has been of some use in relation to polyester/cotton blends but not for the printing of pure or substantially cotton fabrics [41,42]. A method for the introduction of propane sulphonyl groups by exposing cotton to propane sulphone vapour for 60 minutes at 60 °C has also been examined [43].

Consideration of the physical chemistry of the situation suggests that the most effective modification would involve the introduction of substituent groups with high binding potential in their own right, such as aryl or aroyl groups, rather than alkyl substituents which have the primary effect of blocking hydrophilic centres in the cellulosic chain. The degree of substitution of cellulose by benzoyl groups which is needed to produce significant affinity for disperse dyes is quite small, and if the process is carefully controlled benzoylation of cotton can be used to produce an excellent transfer-printable cotton [44]. Another avenue which has been explored has been pretreatment with vinyl monomers [45].

Physical (rather than chemical) modification of cotton has also been investigated. In this connection investigations have been carried out on pretreatment of cotton



with high-boiling ($> 150\text{ }^{\circ}\text{C}$) swelling agents to open up the structure to disperse dyes, which become entrapped [46].

But while chemical or physical modification pretreatment processes may be of scientific or technical interest, they do not fit well with the structure of the textile print market. One of the advantages of transfer printing is that the fabric is committed to a design as late as possible in the production chain, and only to the degree supported by potential sales. Pretreatments of this kind imply a commitment to future transfer printing, although not to any particular design, at a very early stage and consequently this has greatly limited commercial interest.

Pretreatment of cotton fabrics with resin preformers is well established in textile processing, and can be carried out by a simple padding and drying application just before printing. Thus it does not suffer from the major disadvantage of the more fundamental modifications discussed above. Resin finishing agents based on hydroxymethylmelamine, used to confer crease resistance to polyester/cotton or cotton fabrics, also provide a substrate that is fast to washing and has good affinity for disperse dyes. Thus by impregnating the fabric by padding with an aqueous solution of the resin precondensate and drying followed by sublimation transfer in the usual way, the resin is simultaneously printed and cured, to give a fast to washing result [44,47–52]. It is essential that the resin impregnation be uniform, as otherwise printing will be uneven. Thus the resin application requires more care than is usually required in the resin finishing of fabrics, where any defects tend to remain invisible. Also the drying conditions need to be controlled in order that the partial curing, which inevitably occurs during drying, takes place consistently.

During curing of the precondensate in the transfer printing, formaldehyde (methanal) is emitted. This has to be minimised for health and safety reasons and the operation needs to be carried out with suitable extraction. The amount of formaldehyde produced depends upon the particular condensate selected. The melamine molecule possesses six hydrogen atoms which can be replaced by reaction with formaldehyde to produce ultimately hexahydroxymethylmelamine (HHMM). All the condensates can be etherified to form a whole range of alkoxymethylmelamines. These products have different degrees of reactivity and yield free formaldehyde to different extents during condensation. From all points of view the best results are obtained in transfer printing when using fully substituted HHMM. Formaldehyde emission can be further reduced by partly replacing HHMM with a polyurethane. Although polyurethanes are of no value on their own as transfer-printing resins they condense readily with HHMM and similar products to give durable soft finishes without loss of effectiveness as an aid to transfer printing, while at the same time reducing the HHMM requirement.

The approach so far described is suitable only for the printing of continuous web.



Garments and garment panels cannot be pre-impregnated with the same convenience and consequently methods have been sought to transfer the resin binder at the same time as the dye. Since the resins and resin preformers used do not sublime, their transfer involves other mechanisms which it is more appropriate to consider in relation to melt and film transfer.

No satisfactory substitute for formaldehyde-yielding resin formers has been found and, in view of the drive by leading retailers to eliminate such materials from their ranges, it is likely that the use of the currently available pre-impregnation route to sublimation transfer printing cotton will decline.

3.3 MELT AND FILM RELEASE TRANSFER

These two approaches to producing a transfer print are closely related from a scientific and technical point of view and under some conditions it is not easy to distinguish one from the other. It is consequently more appropriate to consider them together.

Both melt and film release transfer papers are produced using inks to produce an image that softens or melts on heating, and which transfers to the fabric carrying the colouring matters. The colorants do not require to show any substantivity at the transfer stage, which is essentially mechanical. Both methods involve bringing the transfer paper and the fabric together with applied heat and pressure to form a composite shown diagrammatically in Figure 3.10.

Figure 3.10 shows a highly formalised picture of the situation and makes no allowance for the complex nature of the fabric 'surface'. It pictures the situation before the applied pressure has forced any of the softened or molten printed image or ink layer into the fabric or back into the structure of the paper. At this point there will be an adhesive force F_1 between the image and the paper and, if the process is to work, another force F_2 between the image layer and the fabric. Within the image layer there is a cohesive force F_3 . All three forces are temperature-sensitive. Suppose that an attempt is made to separate the paper from the fabric, to which it is now temporarily bonded. If both F_1 and F_2 are significant, a stress force will develop in the image layer. If the temperature is currently above the softening point of the ink then the film will

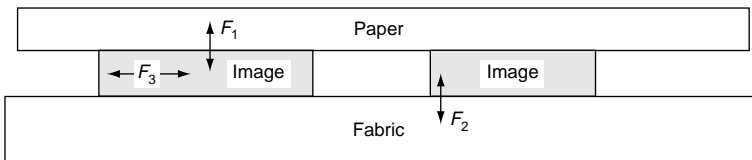

Figure 3.10 Schematic representation of melt/film release transfer

split, leaving an image on the fabric and a residue on the paper. The way in which the split occurs will depend on the relative magnitudes of F_1 , F_2 and F_3 at the time. Applying a high pressure and forcing the fabric into the softened or molten film effectively increases F_2 , and consequently reduces the amount remaining on the paper after separation. Alternatively, if the film melts and wets the fabric and consequently flows over the fibre surfaces, then little pressure will be needed to effect a high degree of transfer. The transfer will be affected also by the interaction of the printed image film in its normal, softened or molten state with the paper surface, in that this will determine F_1 .

A different situation arises where the force F_3 is relatively strong and F_1 is weak. Then the separation of the paper from the fabric will result in the image layer being transferred, substantially intact, to the fabric. This is pure film release transfer. In practice, the film is softened by heating at the same time as pressure is applied, and transfer will be accompanied with some degree of flow into the fabric. Pressure-induced flow and flow due to melting and wetting are closely related, so melt and film transfer are not always easy to distinguish. In both systems the transfer of colouring matter from the paper to the fabric is a mechanical process, rather than one of diffusion. Thus the paper must have sufficient adhesion to the print layer to allow it to be handled and, at the appropriate time and under the appropriate conditions, release it easily and efficiently to the textile. It is a feature of melt and film release transfer systems that coated 'release' papers are normally used to promote the efficiency of transfer to the fabric. The subject of such release papers is therefore one which must be addressed in this context.

3.3.1 Release papers

There is no body of published research concerning release papers, and what is known tends to derive from empirical experience. This is largely because release papers were developed primarily for the self-adhesive label trade. This has fairly simple requirements which can be met using silicone-coated or polyethylene-coated papers. The requirements for a transfer-printing release paper are more complex, however.

In the first place the paper has to be receptive to the printing ink while having excellent 'hold out' properties so that all the ink is drawn from the engraved gravure rollers or taken from the flexographic stereo roller. If screen printed the ink must not mark back on to the screens as they apply the different coloured components of the design. As the quality of the transferred print will reflect completely its quality on the paper (unlike sublimation transfer printing, where some lateral diffusion occurs to hide minor print faults), the print layer must develop a uniform film during drying; thus the paper must be wetted by the ink solvents to a sufficient degree either to allow the ink



to flow or to avoid reticulation. To some extent the performance during printing can be controlled by adjusting the ink formulation, taking into account the differing characteristics of the different printing processes, but clearly there is no point in selecting a release paper which unnecessarily presents problems. Gravure printing lays the ink down in dots reflecting the shape of the engraving and these have to coalesce to give a uniform film in the few seconds before the ink is dried. Flexographic printing lays the ink down in a continuous layer, but it must not flow under the pressure of the print roller to give edge outlining. Screen printing also lays down ink in dots defined by the screen mesh; however, screen inks dry more slowly than gravure inks do, they have greater viscosity and they are applied at heavier coating weights, so obtaining a uniform film is less of a problem. On the other hand the screen has to lift off (or 'snap') from the paper without taking ink with it.

The processes taking place immediately after printing a release paper and during drying are highly complex and have received little scientific study. During drying the ink composition inevitably changes. The various components reach their solubility limits at different times. The rheology and the interfacial tension between the ink and the paper change, and there may be some separation of the components. The surface energy of the release paper will affect the distribution of the separated components in the drying ink layer and, since release is determined by the interaction of the release coating and the component of the dried ink layer adjacent to it, the releasing potential is difficult to predict precisely from the respective properties of the paper and the ink.

Most commercial textile transfer release papers are coated with a solution of Werner chrome complexes of myristic or stearic acid, unlike those used in the label industry which tend to be silicone-coated. This is because silicone papers are difficult to print unless the surface properties are maintained within very fine limits, which are hard to control. On the other hand, the Werner complex coatings give a surface printable by litho, gravure, flexo or screen printing and the coating can be applied in line with paper manufacture if desired. The Werner chrome complexes are cationic and as the applied film containing the release coating material dries, the positively charged moiety is attracted to the naturally negatively charged paper surface; the molecules of the agent thus become oriented with the hydrophobic moiety pointing away from the surface. This provides a very effective release coating for a wide variety of ink systems of use in the production of melt or film release papers. Other release systems can be used in specific systems, including wax-based coatings, UV-cured acrylic materials, and solutions or dispersions of polyamides.

3.3.2 Melt transfer printing

The earliest commercial transfer-printing process for textiles was, in fact, a melt



Contents



Home

transfer process, and it has continued to give excellent results for over 40 years. The Star printing process, developed by Star Stampa Artistici di Milano, uses a multicoated paper substrate as the transfer medium [53,54]. The paper is first sealed with an impermeable coating of, for example, nitrocellulose. It is then given a second coating of low-melting waxes based on oleic resins together with dispersing agents which assist the removal of waxes in the later stages of the process. The design is then printed on to the coated paper by gravure printing using an ink based on drying oils and waxes. Care has to be taken in selecting the materials so that the wax layer does not melt during the printing process and the paper does not adhere to itself under pressure in the printed roll, a phenomenon known as 'blocking'. Transfer is effected by bringing the paper into contact with the fabric and passing the composite between heated calender rollers at fairly high pressure. The ink and wax layers melt and are forced by the pressure into the fabric. The impermeable coating prevents the ink layer from migrating back into the paper, and the transfer is highly efficient. As the composite leaves the nip of the calender the paper is removed, leaving the image on the fabric. The process is then completed by treating the fabric by whatever means may be appropriate to fix the dyes in the transferred image; for example, fabrics transfer-printed using direct dyes may be nip-padded with a salt solution and steamed. If vat dyes have been used in the ink the fabric may be impregnated with caustic soda/hydros solution and steamed. The residual waxes from the transfer ink and coating are removed during final washing of the fabric. The efficiency of the transfer process is dependent upon the ease of release of the image layer and since this is achieved by the use of a high-pressure calender the process has not been widely adopted. The Star printing process is capable of producing very high-quality prints, however, and by the use of gravure printing outstanding design work is possible.

Many attempts have been made to develop processes analogous to Star printing which do not require high pressures to effect transfer. Sandoz have patented a process that uses an ink containing dyes that do not melt or sublime together with a polyglycol or an ether or ester derivative of a polyglycol which is transferable at 120 °C [55]. The agent is said to act as a 'transfer solvent' for the dye. The same concept of transfer by means of a melting-transferable solvent is the basis of transfer papers marketed by Sublistatic [56]. These are recommended for the transfer printing of silk, wool and cotton. They carry a coating that melts at 60 °C, and transfer is carried out using a modification of a standard sublimation transfer calender which applies a roller pressure of 59 kPa (6 kg cm⁻²) to the paper/fabric composite as it is carried under the blanket to contact the heated drum. Although this pressure is not low, it is much less than that used in Star printing. As the dyes are not required to become fully penetrated during the dwell time in the transfer machine, operating temperatures can be, with advantage, lower for the printing of fibres such as silk.



After the transfer is completed the dyes are fixed, in the same way as for Star printing.

This transfer system lacks the simplicity that characterises sublimation transfer printing and as far as cotton printing is concerned it cannot be regarded as offering any advantage over pigment printing, which accounts for over 50% of printed cotton. It could, however, be a useful one if it can be adapted to be suitable for the printing of reactive dyes.

Melt-transfer systems for the printing of garments or garment panels have been available for some time. The successful ones have been developments on the theme of applying a resin binding system along with sublimation-transfer dyes using standard transfer-printing equipment. A typical product of this kind has been described by de Vries and Snyder [57,58]. Sublimation printing dyes are printed on to a paper with suitable release properties and then top-coated with a polymeric layer. Suitable polymers have a T_g between -20 and $+50$ °C, and may be chosen from a selection that includes poly(butyl methacrylate), acrylonitrile-butadiene-styrene terpolymers, a vinyl isobutyl ether-methyl methacrylate copolymer and similar materials. The incorporation of urethane groups in the polymer is stated to be advantageous. The de Vries company marketed transfer papers under the trade name CoTon, recommending transfer to be carried out using a standard transfer press for 15–20 s at 195–200 °C. The results had a soft handle and excellent appearance. The transfer mechanism involved the transfer of the polymer accompanied by the sublimation and/or dissolution of the disperse dye to produce a print on the cotton fabric. It is not necessary to employ resins of the kind used in the de Vries process and formulations of waxes mixed with acrylic resins and aminoplast precondensates or other crosslinking agents have also been used successfully. Of considerable interest in this connection has been the successful introduction of the so-called photocopy transfer papers such as Fabrika (CLC Fabrika) and Transphotron (Green Print International), all of which operate as melt release systems. These products offer a coated release paper on which a colour photocopy can be produced using a machine such as the Canon Laser Copier. The images are formed using 'colour formers', which are essentially pigments coated with a low-melting (80 °C) methacrylate resin. The photocopied image can be transferred on to a cellulosic fabric using a standard transfer press operating at 190–200 °C for 15–20 s. The results meet the normal commercial standards for washing fastness and the system is used both for design work and point-of-sale decoration. Since the photocopiers produce prints of photographic quality which are accurately transferred to the fabric, the image quality on the garment is excellent. The most advanced photocopiers can be modem-linked so that designs can be line-transmitted and reproduced on garments within seconds. The Fabrika system is based on the use of vinyl esters [59], but a variety of other resins can be used successfully as a basis for these papers, including acrylic and



other systems which can be formulated with modifying agents such as plasticisers or crosslinking agents.

3.3.3 Film release transfer printing

As the name implies, film release deposits the printed image as a virtually coherent film on the textile material. Such systems have been used for several years with great success worldwide for the decoration of garments; their use for printing continuous-web fabrics, which have to meet different criteria, has not so far proved commercially viable, although the technical problems presented are well understood.

The most widely employed transfers employed for the printing of cotton garments are based on plastisol inks. These consist primarily of finely dispersed vinyl chloride copolymers in nonvolatile plasticisers such as dioctyl phthalate, tricresyl phosphate or chlorinated paraffins together with pigment as colorant. Plastisol inks are used for both direct textile prints and the production of transfers. One of their most useful characteristics, as far as the printer is concerned, is that they do not dry. They contain no solvent and do not block screens by drying. When heated, however, they congeal or set by internal crosslinking and the prints become dry to the touch. The image remains thermoplastic and this property enables the prints to be used in transfers.

Two main methods are used for the production of transfers. One method is to print on to a release paper, usually one that is coated with a Werner complex, using a semidrying lithographic ink system and then to blotch screen print over the image using a white or grey plastisol backing coat. After application of the backing coat the print is passed down a drying oven to set the plastisol layer. Alternatively the image can be directly printed using fine screens and plastisol process inks. The image layer is thin and does not have high covering power, so an additional plastisol backing layer is normally required. Both methods enable images of high photographic quality to be produced. A third method of production is to make the image using screens which put down the full image layer in a single application.

The production of the transfer print may be carried out using a transfer press at 165–190 °C for 10–20 s, during which time the film softens and is forced into the fabric. After removal from the press the composite is allowed to cool and the image to reset. The paper can then be removed.

A variety of transfer equipment is used, ranging from standard transfer units such as that shown in Figure 3.7 to semicontinuous units such as the Reliant press shown schematically in Figure 3.11. In presses of this type the transfer is placed on to the garment on the moving belt, and passes into the machine. As the fabric enters the oven the top belt moves into contact, holding the cloth and paper together while they are heated. Just before the garment leaves the oven the pressure roller forces the two



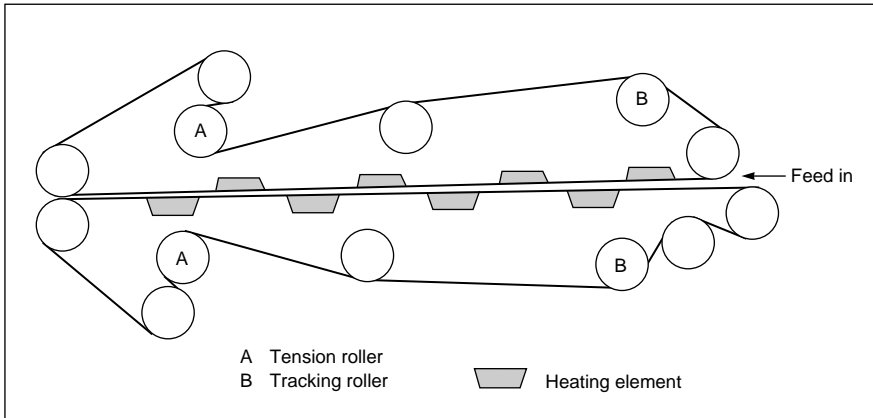

Figure 3.11 Rotary transfer press (Reliant)

closer together and the composite leaves along the belt for the paper to be removed when the print is cool. Continuous rotary presses are made by several manufacturers and employ different heat-input and pressure-application systems. They are characterised by high productivity compared with standard presses.

When an unmodified plastisol ink is used, the development of adhesion between the heated thermoplastic image and the cotton fabric is slow. There are two reasons for this. The first is that at the transfer temperature steam is generated from the fabric, due to regain moisture being released. This provides a barrier to contact between the hydrophobic plastisol and the fabric. The second is that the plastisol does not readily wet the hydrophilic fabric. Bonding can be increased by applying more transfer pressure (as discussed in relation to Figure 3.10), but this increases the risk of fabric being pushed through the image. Increasing the transfer time helps, but at the cost of a loss of productivity. Consequently an adhesive is frequently applied as the final coating layer of the transfers and this acts as a flux.

After transfer plastisol prints remain thermoplastic and consequently printed garments, though fast to washing, can be ironed only on the reverse of the fabric. Early versions of these prints gave rise to problems even in tumble drying, but the quality of contemporary transfer prints is much higher as a result of more informed formulation.

There are several variants of the plastisol transfer theme. Some plastisol transfer papers are made to be used in so-called 'hot-split' systems. Although the paper used for these is not a release paper it must have good 'hold out' properties. In these systems the paper is peeled away from the composite while it is still hot from the transfer press. In peeling, the image is split between the paper and the fabric. Referring back to Figure 3.10 and the relation between the operating forces, it is



clear that for a hot-split system the film must melt and flow into the fabric under the operating pressure more than would be required for a cold-peeling system; otherwise the splitting of the film on peeling would leave too much residue on the paper. Consequently inks for hot-split systems have to be formulated specifically for that purpose, and the vinyl polymers and plasticisers selected tend to melt or soften at slightly lower temperatures than those for cold peeling. The prints are somewhat softer than regular plastisol transfers and have less covering power when applied to coloured fabrics.

Another kind of plastisol transfer incorporates a so-called 'blowing agent', such as 1,1'-azobisformamide, which generates gas within the soft hot ink and causes it to expand. This process has to proceed more slowly than the development of adhesion, so that the print can expand to give a 'stereo' effect as it leaves the press without being blown off the fabric. Rapid release from the paper support is also needed. Plastisol transfers are not used for the printing of continuous-web prints because the market requirements differ. Whereas the application of plastisol transfers to garments takes the form of decoration to enhance market appeal, prints on continuous webs require to have soft textile handle and heat stability as well as fastness to washing, rubbing and so forth. Consequently the transferred film must be removed at the end of the process by washing, or be broken down during the transfer operation under the stress of the pressure used in application, or be thermally unstable so that it loses its film properties during dye fixation. The first approach suffers from the disadvantage of being a wet process. The second is quite easy to achieve as regular pigment-printing binders containing pigment can be easily transferred from a release paper on to cotton fabrics using moderate pressures [60]. The binder film transfers but breaks down under the transfer pressure. Unfortunately pigment-print binders are very strong film-formers and make unsuitable bases for printing inks for a variety of reasons. If applied in thin layers by gravure, they block the engraved rollers. They do not cause screen blocking when diluted, but screen printing with water-based inks on a non-absorbent release paper leads to problems of paper stability and maintaining register. Also pigment-print binders in the uncured state on paper have a tacky surface which makes the papers unsuitable for use. The third method exploits the potential energy stored in certain kinds of film formed by evaporation [61].

If a surface is coated with a solution of a film-forming polymer and then allowed to dry by evaporation, changes take place in the polymer solution as it becomes more concentrated. In the formation of the original polymer solution, the intermolecular cohesive forces were broken down by competition with solvent molecules. In the reverse process that takes place as the solvent evaporates these cohesive forces begin to reassert themselves, but as drying involves an increase in the viscosity of the film the ability of the polymer molecules to achieve optimum internal bonding or the lowest



energy state is limited in the time available, and further molecular migration becomes impossible.

The extent to which the lowest-energy (maximum-bonding) state is reached will depend on the length of the polymer molecules, their degree of flexibility and any steric hindrance provided by substituent groups. Consider poly(vinylbutyral) as an example: evaporation of a solution of this polymer on a release paper surface gives rise to a film which has considerable potential energy, as the bulky butyral groups severely restrict free motion of the polymer as the solution concentrates. If such films are removed from the supporting paper and softened by warming, polymer relaxation then becomes possible as the polymer segments become able to move. The result is considerable shrinkage. It is this property that can be exploited in transfer printing.

After printing an image on to a release paper by appropriate means it can be transferred on to fabric using a heated pressure calender with hot peeling. At this stage the film is intact, but is attached discontinuously at contact points to the rough fabric surface. If the fabric is now heated the film starts to relax but is partly prevented from doing so by virtue of the attachment points. Thus a tension builds up between these points which leads to rupture of the film as it becomes weaker with increasing temperature. The breakdown of the film means that it has little effect on fabric handle and need not be removed at the end of any dye or pigment fixation process. This approach can be used to apply disperse dyes or pigments which may be fixed by the simple application of heat.

It has proved possible to prepare successful printing inks containing reactive dyes and alkali in formulations which are quite stable in the ink solvent. The dye in these cases can be satisfactorily fixed by steaming directly after transfer. The fixation achieved by this means is rather higher than that obtained in much printing with reactive dyes and this factor, combined with easy removal of unfixed dye during washing-off and low dye wastage during the printing of the paper, makes printing reactive dyes in this way cheaper than direct printing. The reactive dyes used have to be free from many of the components added during their normal standardisation; as a result of the difficulty in ensuring supplies of dyes in a suitable form, the method has not been commercially exploited.

3.4 WET TRANSFER PRINTING

The principle behind wet transfer processes is the use of water as the medium through which dye diffuses in passing from the paper to the fabric. Thus it resembles sublimation transfer printing in that it is a diffusion-controlled system, but since water is used instead of vapour it is not restricted to the use of dyes that can sublime. The first commercial exploitation of this approach dates from the introduction of the Fastran



process in 1971 [62]. This involves padding wool garments with stabilised thickeners to obtain an expression of the order of 1:1 and then bringing the wet garment into contact with a transfer paper printed with acid or reactive dyes. The composite is then heated in a press for several minutes during which time the dye migrates to the fabric and becomes attached in the usual manner. The method is not highly productive but is quite suited for the printing of high-value articles such as knitted woollen garments, especially when novel design effects are obtained at the same time.

Several attempts have been made to devise continuous wet transfer systems. The DewPrint machine introduced in the late 1970s (shown schematically in Figure 3.12) offered an ingenious solution to the problems posed [63].

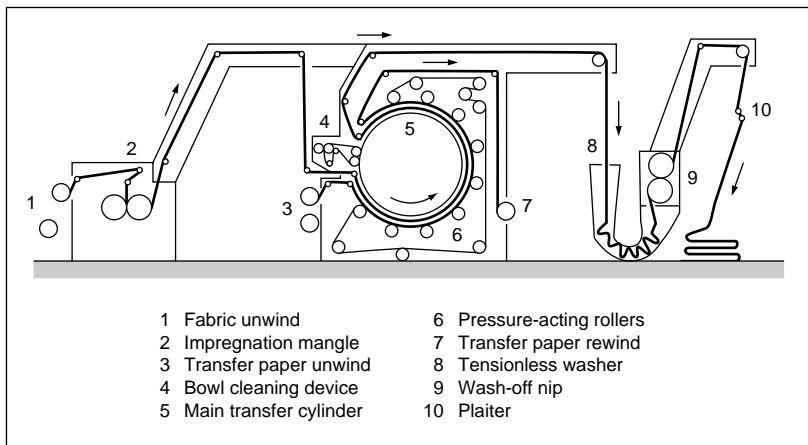

Figure 3.12 Wet transfer-printing machine (DewPrint)

The major difficulty to be overcome in a system of this kind is how to maintain the contact pressure holding the paper to the fabric continuously at the required level over a period of time. This cannot be achieved simply by using a stretched blanket as in sublimation transfer. Consequently the DewPrint machine was fitted with a series of pressure rollers around the heated transfer cylinder, which exert a steadily increasing pressure up to but not exceeding the pressure of the mangle used initially to impregnate the fabric. The major drawback of this solution to the problems was the capital cost involved, which seriously affected adoption of the approach.

Continuous wet transfer continues to be of interest, and new equipment has been recently introduced by Küsters in association with the Cotton Art process developed by Dansk Tranfertryk for transfer printing reactive dyes using their specially developed transfer paper [64].

REFERENCES

1. V Kartaschoff, *Helv. Chim. Acta*, **8** (1925) 928.
2. British Celanese, BP 293 022 (1929), 349 683 (1931).
3. P L Meunier, H Landerl and R J Thomas, *DuPont Dyes and Chem. Tech. Bull.*, **18** (1962) 53.
4. Sublatic SA, French P 1 223 330 (1960).
5. J H Ripper in *Heat transfer printing*, Ed. E P Dempsey and C E Vellins (Sale, Cheshire: Interprint, 1975) 41.
6. K Lohfink, *Chemiefasern*, **41/93** (May 1991) 498.
7. F Aumann, *Chemiefasern*, **41/93** (Nov 1991) E169.
8. W J Inman in *Heat transfer printing*, Ed. E P Dempsey and C E Vellins (Sale, Cheshire: Interprint, 1975) 9.
9. Durand, USP 4 587 155 (1985).
10. J Griffiths and F Jones, *J.S.D.C.*, **90** (1977) 176.
11. K Consterdine in *Heat transfer printing*, Ed. E P Dempsey and C E Vellins (Sale, Cheshire: Interprint, 1975) 15.
12. FP Licensing, BP 1 525 507 (1974).
13. G Holland and A Litherland, *J.S.D.C.*, **87** (1971) 488.
14. Toyobo, Japanese P 75 13 685 (1975).
15. CGY, German P 1 936 461 (1970).
16. H Hoyer and W Peperle, *Z. Elektrochem.*, **62** (1958) 61.
17. CGY, USP 3 632 291 (1972).
18. Kodak, BP 1 412 963 (1975).
19. I McDarmaid, PhD thesis, University of Leeds (1975).
20. A L Cate *et al.*, *Text. Chem. Colorist*, **6** (1974) 242.
21. CGY, German P 2 521 988 (1975).
22. BAY, German P 2 325 155 (1974).
23. R J Goddard, *J.S.D.C.*, **93** (1977) 198.
24. H Broadbent, *Dyer*, **159** (1978) 83.
25. F Schlaeppli, *Text. Research J.*, **47** (1977) 203.
26. I D Rattee and M M Breuer, *The physical chemistry of dye adsorption* (New York: Academic Press, 1974).
27. S Tsuruoka and H Kojima, *Sen-i Gakkaishi*, **24** (1968) 27.
28. K V Datye, P J Kangle and B Milicevic, *Textilveredlung*, **2** (1967) 263.
29. L Anselrode, *J.S.D.C.*, **93** (1977) 201.
30. T G Majury, *J.S.D.C.*, **72** (1956) 41.
31. R S Bradley, C L Bird and F Jones, *Trans. Faraday Soc.*, **56** (1960) 23.
32. H Kojima, *Sen-i Gakkaishi*, **25** (1969) 540.
33. F Jones and R Seddon, *Text. Research J.*, **34** (1964) 373.
34. R A Fenoglio and E J Gorondy, *Text. Chem. Colorist*, **7** (1975) 84.
35. M Bosnaky, MSc thesis, University of Leeds (1975).
36. F Jones and T S Leung, *J.S.D.C.*, **90** (1974) 286.
37. F Jones in *Textile printing*, 1st Edn, Ed. L W C Miles (Bradford: Dyers Company Publications Trust, 1981) 80.
38. T L Dawson, *J.S.D.C.*, **89** (1973) 478.
39. H C Cheung, MSc thesis, University of Leeds (1975).
40. J R Brown and B C Ennis, *Text. Research J.*, **47** (1977) 62.
41. K Nishida *et al.*, *Amer. Dyestuff Rep.*, **63** (2) (1974) 36, 76.
42. Heberlein, BP 1 441 203 (1973).



43. K Koiso *et al.*, *Amer. Dyestuff Rep.*, **69** (11) (1980) 40.
44. U Einsele *et al.*, *Melliand Textilber.*, **62** (1981) 967.
45. S Kubota, *Sen-i-Gakkaishi*, **39** (1983) 421.
46. Toyo Boseki, BP 1 403 119 (1975).
47. LBH, BP 1 460 742 (1973).
48. H Schulzen, *Textilveredlung*, **11** (1976) 9.
49. Tootal, BP 1 524 841 (1975).
50. BASF, BP 1 552 823 (1975).
51. E Leimbacher, *Textilveredlung*, **12** (1977) 209.
52. H Sayle, *Textil Praxis*, **35** (1980) 1344.
53. Albini-Colombo, USP 2 583 286 (1948).
54. Cicogna, USP 2 911 280 (1953).
55. S, BP 1 410 703 (1976).
56. I Holme, *Dyer*, **177** (1992) 14.
57. de Vries and Snyder, USP 4 021 569 (1977).
58. de Vries and Snyder USP 4 058 644 (1977).
59. Kalro, European P 91 306 342.2.
60. I D Rattee, unpublished work.
61. I D Rattee, *J.S.D.C.*, **93** (1977) 190.
62. Dawson (Holdings), BP 1 284 824 (1971).
63. K Wild, *J.S.D.C.*, **93** (1977) 185.
64. *Internat. Text. Bull.*, **38** (1992) 63.



CHAPTER 4

Carpet and yarn printing

Timothy L Dawson

4.1 HISTORICAL DEVELOPMENT OF CARPET PRINTING

The initial development of the printing of carpet piece goods took place in the UK shortly after the introduction of tufted carpet production, which followed the lead given by the USA from the early 1950s onwards. The manufacture of broadloom tufting machinery expanded rapidly in the period 1956–64, with continuous improvements in sophistication and productivity following the establishment of such firms as British Tufting Machinery, Cobble Bros (subsequently Singer Cobble), Ellison Tufting Machinery and Edgar Pickering of Blackburn. By 1980 tufted carpets constituted 80% by area of all soft floor coverings made in the UK, and half of these were printed. The desire to print tufted carpets arose because of the then very limited patterning potential of tufting machines; even today, despite the advent of the Hydrashift and Graphics machines, with which it is possible to produce patterns comparable with those seen in two- or three-frame woven Wilton carpets, tufters cannot imitate the more complex multicolour designs of printed carpets. Some improvement in design appeal became available with the introduction of space-dyed and differential-dyeing nylon yarns and with variable-pile-height tufting mechanisms using the ‘buried end’ pattern effect. The UK market was, however, accustomed to traditional Axminster designs and it was therefore opportune to look to printing techniques to achieve greater flexibility.

Three prototype machines were designed during 1957–60, of which two involved surface roller printing (a principle that had long been used for some types of textiles and for wallpaper printing) and the third a novel dip printing process. The two surface roller printing machines (developed independently by BTM and Stalwart Dyeing Co) incorporated wooden printing rollers carrying raised designs covered with rubber. Each roller rotated in a trough of dye liquor placed below it, and the pile of the carpet was pressed against the patterned surface by a counter-pressure roller. The BTM machine



was not developed further but the Stalwart machine went on to prove popular, particularly in the USA.

During the same period Deep Dye Industries, USA, patented a novel machine in which each colour area of the design to be printed was defined by flat-bottomed, shallow troughs fed with dye liquor. The carpet was pressed, face downwards, on to this printing 'plate'. Thus all the colours of the design were printed simultaneously, which obviated the registration problems of all other methods. The process was particularly good for long-pile carpets, but never achieved widespread usage. The initial preparation of patterns for both these early systems was slow and labour-intensive and required considerable craftsmanship, being comparable to the making of hand-printing blocks.

Early attempts to use conventional flat-screen textile-printing machines for carpets quickly showed that a completely new design would be necessary to obtain satisfactory penetration of the print paste into the carpet pile. This was first achieved by Carpet Printers Ltd (Bradford Dyers' Association), who produced a machine that utilised a vacuum slot beneath the carpet surface to achieve penetration of the paste into the pile. The machine, which enjoyed modest success in the UK and America, was very ruggedly constructed for, in contrast to a textile printer, extremely heavy engineering is required for the intermittent transport of the carpet (which may weigh as much as 4 kg m^{-2} when wet) and also to raise and lower the large screens (up to $5 \times 1.2 \text{ m}$ in size). During these early days printed carpets carried a definite stigma, as did tufted carpets in general, since they sold at the low-quality end of the market and had poor wear performance, viscose rayon being the main fibre used. Indeed, manufacturers tended to hide the fact that the carpets had been printed by using such phrases as 'design dyed' and 'pattern dyed'!

The situation improved, however, with the increasing introduction of nylon carpets and a trend towards finer tufting gauges and low-level loop carpet constructions, which were well suited to carpet printing using the newer flat-screen and later rotary-screen printing machines. From the mid-1960s onwards, following the introduction of the Peter Zimmer machine, carpet printing expanded rapidly, especially in the USA, the UK and, to a lesser extent, Germany. Fashion is cyclical, however, and the carpet trade seems to favour a slow swing between plain shades (or very muted patterned effects) and multicolour Axminster-type designs. This trend, together with increasing competition from Europe and in particular from Belgium, has affected the share of printing in the UK, and the present-day industry is much smaller than it was 10–15 years ago (Table 4.1).

Printing carpets in piece form is the most logical approach to achieve minimum stockholding and the fastest reaction to customer demand. For a time, however, certain forms of yarn printing were used for the production of tufted carpets. The production of



Table 4.1 Estimated size of printed carpet market

	Production of tufted carpets /m ² × 10 ⁶		Proportion of tufted carpets printed as yarn or in piece form/%			
			As piece		As yarn	
	1980	1990	1980	1990	1980	1990
USA	920	1028	25	10	10	4
Germany	120	129	15	19	27	1
UK	125	113	50	33	10	1
Belgium	120	222	15	43	30	3
Japan	100	141	0	3	0	0

tapestry yarns for patterned woven carpets was practised over 150 years ago, the main process using a large drum round which a warp of yarns was wound and printed in a complex, preset design. After the dye was fixed and excess dye and chemicals washed off, the yarns were beamed and then woven into a fully patterned carpet on a single-frame Wilton loom. With the advent of tufted carpets, similar techniques were examined with the aim of overcoming the lack of patterning potential of the early tufting machines. It soon became clear that differences in tension, shrinkage and so on between individual yarns comprising the warp were too great, and pattern fit was easily lost during printing, steaming, washing and drying. Two warp-printing processes were, however, devised independently in the USA by Westpoint Pepperell and Crawford/Mohasco (the latter's product being subsequently commercialised as the Crawford Pickering machine).

Of much greater importance was the warp printing of yarns with random bands of colour to yield attractive, random speckled designs on the tufted carpet, an effect which became fashionable from the 1960s onwards and still remains popular, particularly in Europe. A completely different approach, the knit-deknit method, was also devised in America and is usually ascribed to Fred Whitaker, who claimed to have originated the term 'space dyeing'. This technique involved pad dyeing of the yarn in tubular knit form, followed by overprinting with multicoloured stripes using surface or engraved printing rollers. Many other space-dyeing systems have since been devised, but somewhat similar effects can now be achieved more economically using producer-intermingled, differential-dyeing nylon yarns.

None of these approaches to the production of patterned carpets represents the end of the road, however. The use of computer-aided design (CAD) systems for the



preparation of textile patterns, which can then be stored as digital information on floppy discs, is now commonplace. This information can then be used to produce negatives for colour separations or, more directly, for the laser engraving of lacquer screens. The next logical step is to use the digital data more directly still, i.e. to drive the printing mechanism, and this has been achieved in various ink-jet printing machines. This type of advanced printing system is typified by Milliken's Millitron and Zimmer's Chromojet machines. These systems still use conventional dyes which require fixing and washing off, but there is no basic reason why colour application should not be the very last process applied to the carpet. This is the case with the printing of carpet tiles and rugs using the transfer printing techniques described in Chapter 3.

The historical development of carpet printing has been reviewed by a number of authors [1–3].

4.2 YARN PRINTING (SPACE DYEING)

Although the printing of yarns for true patterned effects proved very difficult to control, the random space-dyed effects that can be more readily attained by a variety of yarn-printing methods have continued to be popular. The patent literature abounds with systems for producing coloured flecked effects on yarns but the two most successful methods entail either warp printing or colour application to a tubular knitted 'sock'. The essential process sequence begins with dye liquor application, followed by steam fixation, washing-off and drying

Various warp-printing methods have been used over the years. In most present-day systems several ends of carpet yarn are taken from wound packages on a creel and colour is applied, either by lick rollers or by some form of spray or spinning disc applicator, to the yarns. The yarns are carried past the print heads in warp form or lying on a brattice on which they have been laid down in a continuous circular or elliptical coil. Warp printing tends to give the so-called 'long spacing' designs in the tufted carpet produced from them.

Knit-deknit applications, on the other hand, tend to give characteristically speckled 'microspaced' designs, because of the limited degree of penetration of dye liquor achieved by the duplex printing rollers into the yarn sock.

Although the end-effects produced by the two methods are basically different, the processes can be modified so that their results are more closely comparable. Thus the long spacing effects of warp printing can be imitated by overall application of a ground colour followed by colour spotting with segmented lick rollers or oscillating jets of dye liquor. Similarly oscillating jets of liquor can be applied to knitted sock and excess liquor squeezed out before steaming. This leaves large coloured areas with good liquor



penetration and, when tufted, the long spacing effect is achieved. Some examples of machines used for space dyeing are listed in Table 4.2.

Table 4.2 Space dyeing systems

Yarn application	Knit–deknit application
Martin Processing	Fleissner
Callebaut de Blicquy	Ilma
Superba ^a	Whitaker
Hoerauf ^a	Murphy

a In these machines dye fixation and heat setting of the yarns is achieved simultaneously

In contrast, the Crawford Pickering warp-printing system was designed to produce fully patterned tufted carpets with up to eight colours. The warp of yarns was passed between a pair of cylinders, around the surface of which were mounted rows of small dye applicator pads (about 20 mm square). The lower cylinder dipped into a trough of dye liquor (in a similar manner to the Stalwart printer described in section 4.3.1) and dye was thus picked up on the surface of the pads. These pads could be actuated mechanically so that when opposing pairs were in the raised position the yarn passing between them was printed. With a typical 5 mm pile height carpet, a 20 mm printed length of yarn was equivalent to two tufts of the final carpet. With longer pile carpets of the Saxony or shag pile type single tuft definition was possible, and it was on such carpet constructions that the best results were ultimately obtained. In the original machine the pattern control mechanism was a movable notched bar, the positions of the notches determining the raising or lowering of the print pads. Preparation of pattern bars was therefore rather tedious; later, one company introduced electropneumatic actuation of the individual print pads with pattern data provided from a microprocessor. Ultimately, however, the full patterning potential of this machine was not realised, mainly because of the problem of keeping a warp of printed yarns in register. There is now only one machine left in operation.

4.3 CARPET PRINTING

4.3.1 The Stalwart machine

The print head of the Stalwart machine consists of up to four print rollers, which run in troughs containing a thin print paste, with the carpet pile to be printed being

pressed against the upper surface of the print roller from behind. The print rollers are arranged at 45° to the vertical, one above the other (Figures 4.1 and 4.2). Maximum running speed is about 6 m min^{-1} . The individual print rollers consist of a steel-centred wooden bowl on the surface of which is mounted the design. The design is cut from thick rubber sheet covered with a nylon or polyester fibre pile. The relative simplicity of this machine ensured its success at a time when two- or three-colour blotch designs on plain ground shades were popular. Fitting patterns with 100% coverage cannot be printed, so the ground shades are obtained either by printing on predyed carpet or by wet-on-wet printing on to a preppeded or cover-printed ground. There is also limitation in line definition, as the narrowest rubber strip that can be mounted on the roller is about 4 mm wide. The machine has, however, proved ideal for the production of the so-called shadow-printed effects on long-pile carpets, which have remained in fashion for many years.

4.3.2 Flat-screen printing machines

Initially there were two types of flat-screen printing machines for carpets, namely the BDA machine (manufactured for a time by Singer Cobble) and that produced by Peter Zimmer.

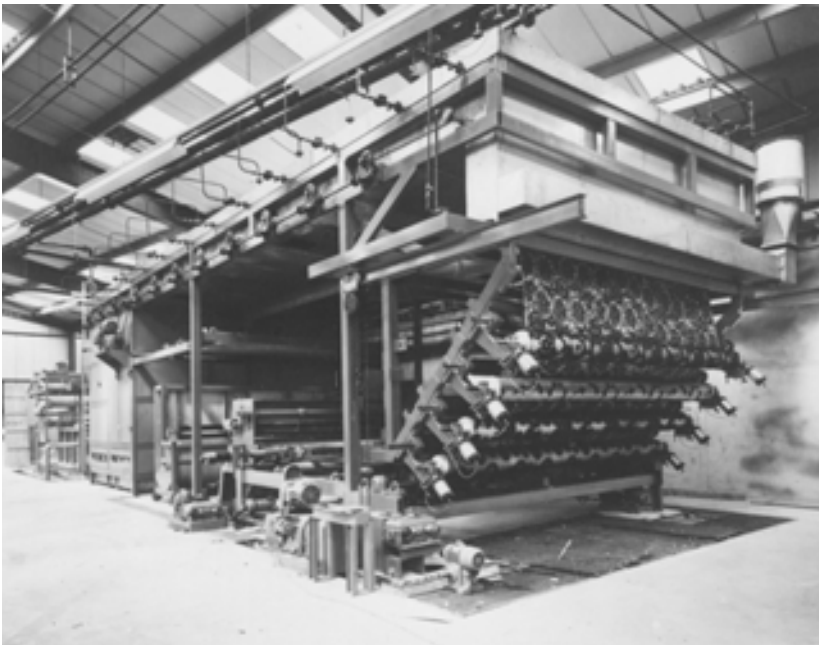

Figure 4.1 General view of the Stalwart printer

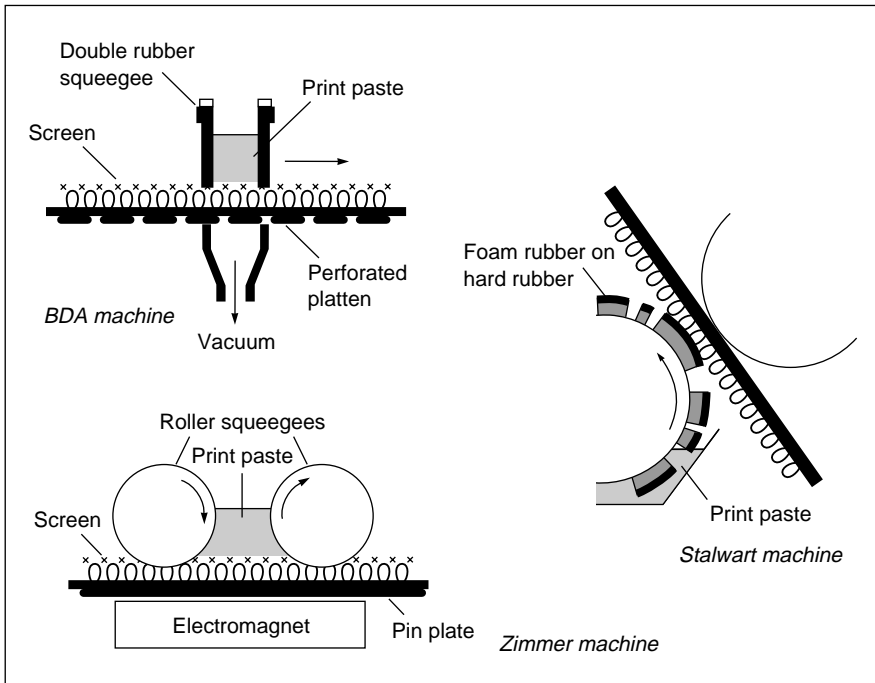

Figure 4.2 Principles of the Stalwart, BDA and Zimmer machines

BDA machines remained in operation until 1990 but none is still in use, although this machine is of some interest from a historical point of view (section 4.1). In this machine a reservoir of dye was confined between the blades of a double squeegee, and good pile penetration was obtained by applying a vacuum beneath the strip of carpet over which the squeegee passed (Figure 4.2). To achieve this the conventional rubber transport blanket was replaced by an endless belt of perforated metal platens, which carried the carpet forward when the screens were lifted after each printing cycle. Despite the relatively low vacuum used (about 75 mm water gauge) it was possible to obtain good penetration on fairly long-pile carpets. The maximum running speed of the BDA machine was about 5 m min^{-1} .

The Peter Zimmer machine operates on the principle of the electromagnetic double-roller squeegee, the print paste being confined between the two rollers which are of a considerably larger diameter (80 mm) than those used on the similar Zimmer flat-screen printer for textile fabrics. Pile penetration by the print paste is achieved by the 'pressure wedge' of paste trapped in front of the second roller as it moves forward over the screen (Figures 4.2 and 4.3). As in the BDA machine, the screens are covered with 60–70 mesh polyester screen fabric. The downward pressure and reciprocating



motion of the squeegee rollers (more than one stroke is usually necessary to achieve good pile penetration) is achieved by a bank of electromagnets moving beneath the endless rubber belt that carries the carpet. Maximum running speed is usually $2\text{--}4\text{ m min}^{-1}$, depending on carpet quality.

As in the textile-printing field, rotary-screen printing has become the dominant method used to print carpets, but there is still a market niche for flat-screen printing where short runs to a pattern or colourway are required (for example, in the custom design field of architect/specifier contracts for prestige buildings).

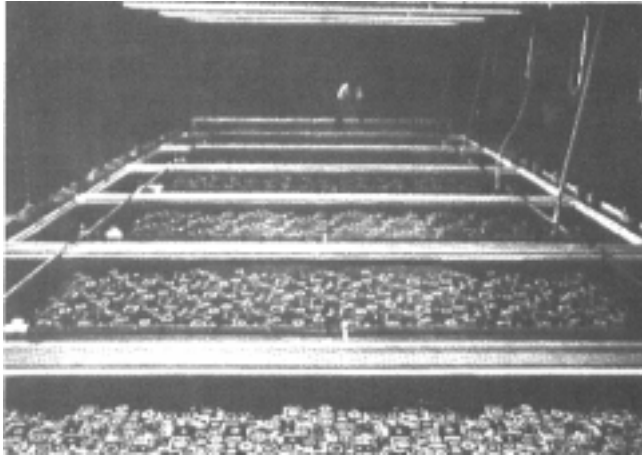

Figure 4.3 View of the Zimmer flat-screen printer from the feeding end

4.3.3 Rotary-screen printing machines

The main difference between rotary-screen printing machines for carpets and those used for textiles lies in the type of squeegee used. All carpet squeegees are considerably larger, and end-rings with wider openings are therefore used. The standard print width is usually 4 m, so considerable storage space is necessary for the many screens and designs used by a typical carpet factory. The screens themselves are galvano nickel of a fairly heavy gauge (0.3–0.5 mm thick), with a much coarser mesh (20–30 mesh) than that used for flat screens (lacquer screens are not used for carpet printing). Standard rotary screens give a pattern repeat of 1 m but larger screens to give repeat sizes up to 3 m can be provided for particular purposes such as printing oriental carpet designs.

The carpet is transported by means of an endless rubber blanket or rubber strips; these sometimes carry small pins on the surface to grip the carpet backing and prevent progressive distortion as the carpet passes under each print head.

- Four types of rotary-screen printer for carpets have been produced, namely:
- the Peter Zimmer machine (now made by Johannes Zimmer, Klagenfurt) with a magnetic-roller squeegee, friction driven with variable magnetic pressure, as in the flat-screen printer; larger screens are possible to give up to 3 m repeats
 - the Peter Zimmer Hydroslot system, which relies on hydrostatic pressure to force the paste through a slot in the special squeegee box and into the carpet pile; screen sizes are as above
 - the Mitter positively driven roller squeegee, which combines the use of a large squeegee diameter and high paste levels behind the roller to achieve good colour penetration into the carpet pile; special flexible screens of triangular cross-section can give repeats up to 4 m
 - the Johannes Zimmer Magnojet and Variojet machines, which are a further development of the Hydroslot system.

The principles of the above machines are illustrated diagrammatically in Figure 4.4, and a general view of a production Zimmer machine is shown in Figure 4.5.

Rotary-screen printers are considerably more productive than the older flat-screen machines. Print speed is 15–30 m min⁻¹, the machine occupies much less space and labour costs are lower. With special screens or actuating mechanisms it is even possible to print pattern repeats of 2–3 m for bordered oriental square designs. The disadvantages include the higher cost of galvano screens and longer screen-changing times (although recent developments in screen-handling equipment have greatly

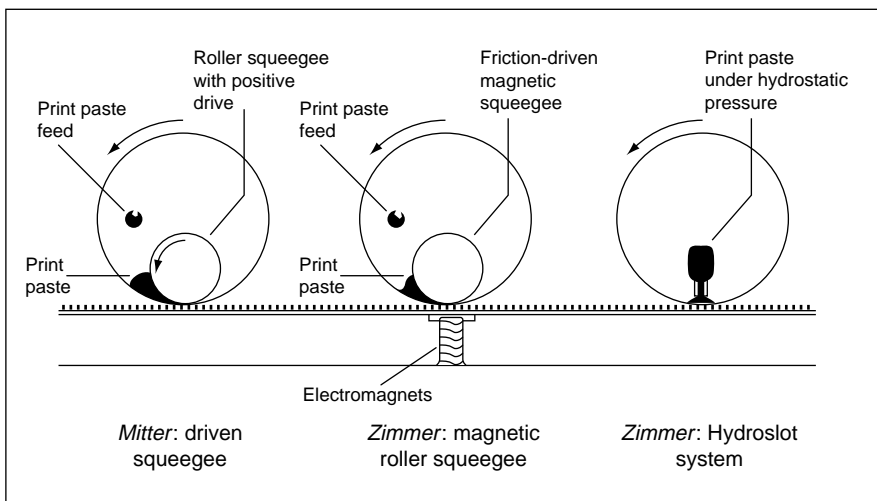

Figure 4.4 Principles of rotary-screen printing

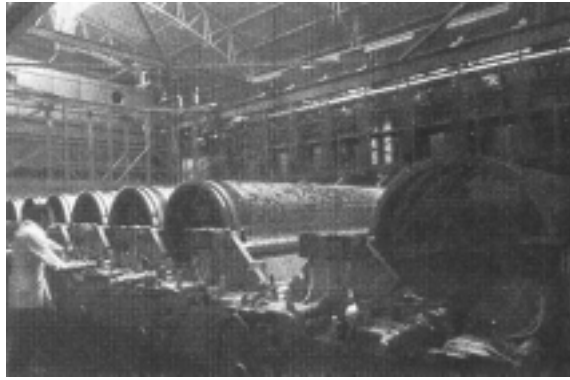

Figure 4.5 Large rotary-screen printer for carpet squares (Zimmer)

improved the situation). There is also a tendency for carpet to spoil during stoppages, because the paste tends to flow fairly easily through the coarse mesh screen whilst it is stationary. The use of thickeners with ‘short’ flow properties (section 7.7.3) can help to prevent leakage from the screens when stopped.

The rotary screens of the Zimmer machines carry driving gears and bearings which are attached to the end-rings. These are in turn supported on adjustable open bearings arranged in a V-configuration. When the screens require changing, each screen is simply lifted out of the open bearing, together with the associated squeegee and colour feed pipe. In contrast the Mitter machine screens run in closed bearings and, to avoid having to remove the squeegee and colour feed pipe before lifting the screen, the whole print head (including the bearings and main support beam) is lifted from the table. In the original production machines the roller squeegee was driven at a slightly faster surface speed than the screen so that a shearing effect was created. This was supposed to increase the flow of print paste through the screen and achieve better pile penetration. It was subsequently shown that this was not the case (section 4.6.2), and as the shearing action produced unnecessary wear of the screen the squeegee and screen speeds were equalised in later models.

The roller squeegees used are of large diameter (80–160 mm) which allows space for the relatively large wedge of print paste necessary to apply sufficient colour to carpets, particularly to dense high-pile constructions. With roller squeegees, there is a tendency for the carpet pile to be crushed as it passes under successive print heads. This is of little importance when printing low-pile carpets, but does lead to inferior print definition in longer-pile constructions. By contrast, the two Zimmer slot squeegee systems exert minimal pressure on the carpet surface and the penetration of the paste (driven by the pressure head behind the paste) can be precisely controlled. In the original Hydroslot



system the print paste was fed into the slot from tall glass columns at the side of the machine and the pressure head was therefore generated statically using level controls. In the more recent Magnetjet system the paste is pumped from a stock tank at atmospheric pressure into a delivery tank which is dynamically controlled at a precise pressure. With this latter system there is much less wastage of paste at the end of the production run.

4.3.4 Spray and jet printing machines

Various machines have been used to produce multicolour patterned effects on carpets over the last 25 years, the effects produced varying from spotted, blotch or streaked effects of a somewhat random nature right through to geometric patterns with regular repeats. Typical examples of such systems that have been exploited during this period are quoted in Table 4.3.

Table 4.3 Multicoloration systems

Maker	System	Description
Küsters	Multi-TAK Küstercolor Foamcolor	Oscillating inclined plane dye applicator Overflowing foam layer, deflected by air jets
Mitter	Multicolor	Divided slot squeegee
Various	ICI Polychromatic	Oscillating dye streams with mangle squeeze
Otting	Jet-Flo Jetfoam	Jets or air-spray jets with on/off control
Gaston County	ColorBurst	Fan-spray jets with on/off control

In the USA the Küsters systems became very popular for the production of a generic carpet design style, which became known technically as Gum-TAK and popularly as 'shadow printing' or 'the American look', and eventually captured more than half the market. This fashion later spread to the UK, where similar effects were produced using a combination of plain colour applicators and conventional carpet-printing machines. The aim of the original Küsters system was to imitate, at lower cost, the pattern effects seen in carpets tufted from space-dyed yarns. Dye liquor picked up on the surface of a lick roller was divided into individual streams by an oscillating doctor blade, and these were further broken up into a random shower of droplets by a chain and oscillating comb system running between the applicator and the carpet surface. The droplets were applied to carpet which had previously been padded with a ground shade liquor. By varying the viscosity of the dye liquor, the composition and pick-up of the pad liquor and the steaming conditions, sharply defined or more diffuse patterns were obtained.



The pattern potential of the TAK machine was further enhanced by the use of doctor blades with cutaway sections which could be opened and closed by a reciprocating drive to produce larger areas of colour. This machine was used to apply patterns to long-pile carpets, particularly cut/loop pile constructions, followed by an overall coating of a plain paste containing only thickening agent. This had the effect of displacing dye from the tips of the cut pile while leaving the shorter loops unaffected, hence the name Gum-TAK. In more recent times the American market has favoured the effects produced by spray jet systems, particularly because these machines are cheaper and can be run at higher production speeds than the TAK system and can also give good results at lower liquor pick-up values.

All the foregoing methods are limited in the type of design effect they produce and, more significantly, cannot be controlled to produce a prespecified design. Thus the equipment must first be employed to produce a wide range of effects, by altering the colours and the mechanical variables, and only then can selections be made from these by, for example, design or marketing personnel. This is one of the fundamental differences between the earlier jet coloration methods and the second-generation jet printing systems, quite apart from the great increase in sophistication of the control mechanisms, all of which are high-speed electromechanical systems.

The first commercial carpet-printing machine based on selective deflection of individual dye jets was the Elektrocolor, made by Textima, of the former DDR. The American Millitron machine was based on the same concept (that of deflecting continuous streams of dye liquor), but the deflection was achieved more precisely with air jets. The later Chromotronic (Zimmer) and Titan (Tybar Engineering) machines were based on the so-called 'drop on demand' principle, namely the use of switchable electromagnetic valves placed in the dye liquor feed tubes to allow the jetting of discrete drops of dye liquor in a sequence predetermined according to the pattern to be printed.

Printing by jet techniques offers several advantages over conventional carpet printing:

- digital pattern data from CAD systems (suitably edited) can be used immediately to drive the printer, hence allowing quick customer response
- there are no screens to handle, and there is instantaneous (electronic) change of pattern and hence much improved machine occupation, making short runs economically viable; for comparison, changing screens on an eight-colour rotary-screen carpet-printing machine takes about 1 h
- no screen replacement or storage space is required
- no physical pressure is exerted on the carpet pile, therefore optimum surface appearance results
- large repeats are possible without resorting to special techniques.



The Millitron machine can be compared with a rotary-screen printer in that the carpet is carried continuously by an endless blanket under a series of jet bars, each of which provides one colour to the overall pattern. Unlike the horizontal arrangement in screen-printing machines, however, the carpet moves up an incline under the print heads (Figure 4.6). Each jet bar carries a series of orifices, 50–100 μm in diameter, spaced at 4 per cm (recently, up to 8 per cm), and under nonprinting conditions the streams of liquor are deflected by opposing jets of air into a collecting gutter, from whence the liquor is recycled. Each air jet has an electromagnetic valve which can be switched, according to the signals received from the processor reading the pattern data, so that the air either deflects the dye stream or escapes to the atmosphere, when it allows a spurt of dye liquor to fall on to the carpet surface. In order to control the quantity of liquor applied to the carpet, which may vary from a lightweight low-level loop type to a heavy-quality shag carpet, it is necessary to vary not only the 'firing time' (the time interval during which the jet is allowed to fall on to the carpet) but also the pumping pressure of the dye liquor in the system.

The Chromotronic machine (Figure 4.7), which was later named the Chromojet, resembles a flat-screen printing mechanism in that the carpet is moved intermittently and printing is carried out by a print head traversing the carpet from side to side whilst it is held stationary on the transport belt. During the traverse, a bank of needle valve jets in the print head are made to open individually in turn at the correct instant to place 'shots' of dye liquor in appropriate positions, so as to build up one colour of the pattern. The print head is relatively large, as the special needle jet valves are about 5 cm in diameter. In the original full-width carpet-printing machine each successive colour was applied by another traversing print head, in a manner analogous to the successive screens in a flat-screen printer. In this process the dye liquor flow is

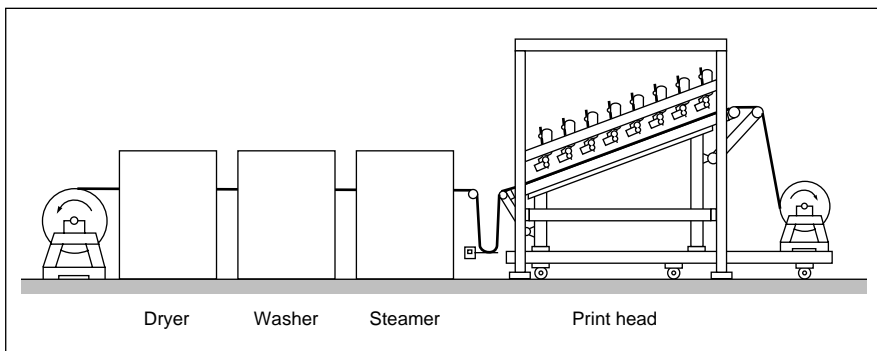

Figure 4.6 Layout of jet printing machine (Millitron)



Figure 4.7 Chromojet printing machine (Zimmer)

intermittent, controlled by means of the high-speed valves which are operated from digital data on magnetic storage discs. Good pattern definition is achieved by having a matrix of as many as 500 jets, each one being slightly offset from the next, in a print head which traverses a 63 cm band of carpet, thus giving a resolution equivalent to around 8 jets per cm. The same definition as that from the Millitron machine (i.e. 4 jets per cm) could be achieved from a Chromojet machine with a print head 1 m wide with 400 jets per head. For the linear carpet production speed to be the same (say 10 m min^{-1}), however, the needle valves have to operate four to five times faster to achieve the same definition in the direction in which the jets traverse the carpet. One type of machine at present on offer can print carpet from 2 to 5 m wide in eight colours from a single print head with 512 jets (64 per colour). The valve opening time ('firing time') is 5–15 ms on the Millitron machine and the liquor pressure relatively low (70 kPa or 10 lbf in^{-2}). The frequency of firing is determined by the speed of printing, but at 10 m min^{-1} would be 69 Hz. The Chromojet machine uses shorter firing times and higher liquor pressures and the valves can operate at up to 400 Hz. The quantity of liquor which needs to be applied to the carpet depends on the carpet quality (particularly the pile height and weight) and is controlled mainly by the selection of the appropriate firing time. Both machines, which were originally designed to print full-width carpets, have been produced in versions designed to print carpet tiles at a definition equivalent to 10–20 mesh.



One type of ink-jet printing technology normally associated with paper printing utilises tiny charged drops of dye liquor which are deflected by passing between electrically charged plates. This principle has been used by Stork as the basis of a sample printing machine. The volume of liquor which the jets can deliver is too small for the system to be used for printing carpet substrates, however, although printing of fabric samples can be carried out satisfactorily.

Much simpler, monochrome ink-jet printing machines have also been used to print the backing side of carpets with motifs such as batch numbers or company logos whilst the carpet is passing down a production line or inspection table. This is possible because data can be instantly updated by the control system and transmitted to the print head, a flexibility that is unavailable with the flexographic roller printing systems more generally used to mark the backs of carpets and particularly carpet tiles.

4.3.5 Foam printing

Mainly as a result of the oil crisis in the mid-1970s the textile industry looked at various possible methods of reducing energy costs. The dyeing and printing of carpets requires considerable energy input, usually in the form of steam, and this is largely due to the substantial amount of liquor applied to the substrate (liquor pick-up may be 300–400%) which must then be heated to 100 °C. Attention was therefore turned to ways of reducing the water content of the carpet prior to steaming.

One approach to this problem, which has also been applied to textile dyeing and finishing, is to use foam as the fluid medium for dye and chemical application. A typical foam for carpet coloration may consist of 10–20 volumes of air to one of water, and it has the flow properties of a viscous liquid. The first successful use of foam to colour carpets was for continuous dyeing, followed by multicolour foam printing. In 1980 Stork introduced a modified rotary-screen printer for textiles using foamed print pastes, and both Mitter and Zimmer produced machines for foam-printing carpet.

In the Mitter printer the print liquor, containing special surfactants, is passed through a microprocessor-controlled foam generator (either a so-called marshmallow pump or a static mixer unit) and the foam is fed through the rotary screen from a slot applicator, not unlike the Zimmer Hydroslot squeegee. The Zimmer system utilises the Variopress squeegee placed inside the rotary screen and the foam is fed continuously by the gear pump system through the applicator slot.

Foam printing has not been without its problems and, in the USA at least, foam applicators have been largely replaced by the simpler spray jet application systems. Both foam and spray systems allow the liquor pick-up on the carpet to be reduced to about 150%, which not only reduces steam consumption but also allows faster running speeds (up to 30 m min⁻¹). In Europe, however, following persistent problems with



respect to levelness, reproducibility and the attainment of heavy shades, the foam printing of carpets has become obsolete. Foam application is still used, however, for less critical carpet-finishing systems such as the application of stain-blocking chemicals.

4.4 PRINTING OF CARPET TILES

Carpet tiles are now being used extensively as an alternative to broadloom carpet, both domestically and increasingly in contract locations such as offices and public buildings. There is a rising demand for patterned effects, ranging from random stipples to multicolour geometric designs or company logos. Tiles are normally machine-cut from a finished dyed or printed carpet which has been given a heavy-quality backing (usually PVC- or bitumen-based). It was soon found, however, that the dimensional stability of preprinted broadloom carpet during drying and subsequent backing operations was insufficient to allow the pattern register to be maintained when the tiles were cut and laid on the floor. The printing of tiles with such patterns, therefore, must be carried out on individual tiles. Attempts were made to use both flat- and rotary-screen printing, but the sublimation transfer printing process (section 4.4.2) proved a simpler solution. More recently Mitter have offered a flat-screen tile printer with a wide variety of squeegee options, a double roller squeegee being recommended for long-pile carpet tiles. If large-volume printing of tiles is required the relatively large investment needed for a jet printing unit is more appropriate.

4.4.1 Jet printing

The Chromotronic machines, now called the Chromojet M and MS, have been particularly successful for tile printing, and a typical machine can print eight colours from a single traversing print head in which are arranged 512 jets (64 jets per colour). Printing speed depends on the definition (usually 10 or 20 mesh) and the number of colours to be printed (commonly four for most tile designs); a typical machine runs at 2–4 m min⁻¹ with a print width of 2 m – that is, four tiles side by side. The tiles may be placed precisely on the transport belt to keep them in register; alternatively, several tile designs, slightly larger than the finished tile size, may be printed on a larger piece of carpet which is subsequently cut into tiles. This avoids a problem that can occur when individual tiles are printed, namely that the very edge of the tile may remain unprinted owing to the tufts being distorted either prior to, or during, passage under the print head. This defect is particularly noticeable if a white-base carpet material is being used. It is more common, particularly when printing logos, to use a predyed carpet as the base material because tiles can then be laid on the floor with the printed ones alongside plain ones of the identical ground shade.



4.4.2 Transfer printing

Of the various transfer-printing methods so far devised for printing textiles only the heat-transfer (sublimation) printing method is suitable for carpet substrates. For best results, however, it is necessary to use specially selected disperse dyes to print the transfer paper. The penetration of the dye into the pile of the carpet can be greatly improved, either by carrying out the transfer process under vacuum conditions or by producing a flow of hot air through both the transfer paper and the carpet pile. Continuous rotary-drum transfer-printing machines, of the type used to print textiles, have been used for carpet printing, but there is a tendency for the pile to be crushed and colour penetration is poor. For printing rugs and carpet tiles, on the other hand, better results are obtained using special vacuum transfer printing presses.

Sublimation transfer-printing techniques can only be used on synthetic fibres – nylon, polyester and acrylic. Polyester gives the best results in terms of the fastness properties achieved, but it is difficult to attain good dye penetration into the carpet pile on this fibre. The use of nylon 6.6 represents the best compromise between the attainment of good print quality with moderately good fastness properties. The main limitations in fastness are light fastness in pale shades and shampoo fastness in heavy shades. As a result of all these limitations transfer printing of carpet substrates has remained relatively unimportant.

4.5 TREATMENTS BEFORE AND AFTER PRINTING

4.5.1 Pretreatment of carpet

In front of the printing machine there are the conventional carpet take-off rolls, a space for butt sewing, a J-box or compensation roller storage unit, followed by a back-beater and a lint-extraction system.

It is not usual to give wet pretreatments to the carpet before printing, because the materials that may still be on the fibre, such as spin finishes, do not in general interfere with the absorption of the print paste or the fixation of the dyes. An exception arises with some carpet qualities, such as fine-gauge velours, the surface appearance of which is greatly improved if they are prewashed at about 60 °C before printing. This prewashing produces a bulking effect on the fibres which cannot be achieved by steaming alone, although presteaming is sometimes used in place of hot water treatment.

In some cases superior print penetration is obtained on prewetted carpet; one example is the printing of longer-pile carpets such as Saxonies using the Millitron jet printing machine. This also allows the application of a background tint to the carpet, which renders any lack of dye penetration or misfitting less noticeable. After wet



pretreatment the carpet is passed over powerful extraction slots to reduce the residual moisture to between 50 and 80% pick-up, depending on carpet quality. Carpets may also be prepadding with a ground shade for certain resist, displacement and discharge processes (section 4.7.4).

4.5.2 Steam fixation of prints

However well the printing stage is carried out, the ultimate results may be spoiled by imperfect steam fixation conditions.

Unlike textile steaming, dye fixation on printed carpets is carried out without intermediate drying, partly because very considerable energy would have to be expended to dry the carpet (having about 250% pick-up of print paste) and partly because the steaming time is much reduced when the process is carried out on wet carpet. The first requirement of the steamer is that it must be capable of transporting the material through its interior without affecting the quality of the goods (by loss of yarn bulk or by pile deformation, for instance) and without allowing unfixed dye to 'mark off' on to other parts of the print. The second requirement is that the steam quality must be such that dyes are fixed as rapidly as possible, without any tendency to 'bleeding' or any loss of clarity of print. To meet these criteria a range of steamers has been produced, the most successful of which are described below.

Yarn steamers

Most yarn steamers employ the brattice principle, the yarn (as a warp, as hanks, in helical coils or as knitted sock) being carried through the steamer held between two opposed endless wire mesh belts or a series of chain-driven slats. The tubular knitted sock used for space dyeing may be treated in single-brattice steamers, whose capacity is greatly increased by overfeeding the material so that it plaits down on to the brattice in a series of overlapping folds.

All yarn steamers are of the horizontal type, as roller or festoon types exert tensions that would lead to a lean yarn with unsatisfactory coverage properties when tufted into carpet. Manufacturers include Ilma and Fleissner for tubular-knit types, and Superba and Hoerauf for coiler types. The coiler steamers are often used for heat setting the yarns and for this purpose operate either at atmospheric pressure with superheated steam or, when constructed with entry and exit seals, with saturated steam under pressure.

Carpet steamers

At the production rates and steaming times (say 10–20 m min⁻¹ and 3–6 min



respectively) that may normally be used, a carpet steamer requires a capacity of 20–80 m. Space is often at a premium and festoon steamers were used in most of the earlier installations, as is still the case for the continuous dyeing of carpets. Experience showed, however, that better print clarity could be obtained if all the steam treatment, or at least the initial stages of dye fixation, could be carried out with the carpet horizontal. Two-pass horizontal steamers were also tried, but these gave problems of marking-off in heavy shades when the carpet ran with the pile side downwards on the second pass. Present-day practice is therefore to use a completely horizontal steamer, if space allows, or a steamer with a horizontal entry leg followed by a festoon section, so that the internal rollers contact the back of the carpet only. Multipurpose steamers are also available; these may be used in either horizontal or vertical festoon mode depending on the particular print style that is being produced.

For optimum dye fixation, air-free saturated steam at 98–100 °C is required. Air is inevitably brought into the steamer by the incoming carpet, and its effect is to decrease not only the moisture content of the steam but also the rate at which the liquor on the carpet is heated up by steam condensing on its surface. Freedom from air is best assured by good steamer design. If the carpet enters the steamer at the top then the entry leg should have a good purging supply of steam and an extract vent should be sited near the entry to the main steamer. Recent practice has been to have both entry and exit at the base of the steamer and to use so-called ‘cloud control’, that is, to maintain a clear air/steam boundary in the base of the steamer by feeding the steam in through the roof of the steamer and to rely on the lower-density steam to displace air from the main body of the steamer. This results in a considerable saving in steam consumption. Even so, ideal steaming conditions are rarely achieved; although the dry-bulb thermometer may read 100 °C or slightly above, the wet-bulb temperature may be only 95 °C, or sometimes even lower. Such conditions lead to inferior dye fixation, particularly if milling acid or metal-complex dyes are being used. Where the steaming conditions vary during a run or from one batch to another, problems of lack of reproducibility of colour yield will result.

Once the liquor on the carpet has reached 100 °C, it is undesirable to surround it with an atmosphere of superheated steam; this may induce a tendency to dry out, which reduces the rate of fixation of some dyes as well as tending to increase ‘frostiness’. In steamers of the wet-sump type superheating is unlikely, but it can occur with dry-sump steamers if the closed steam circuit (used for anticondensation pipes) is run at too high a pressure or if the incoming live steam carries superheat from the boiler. In such cases the closed steam should be run at relatively low pressure and the live steam fed through a pressure-reducing valve and saturator.

A particular problem with dye-fixation conditions may arise with carpet tiles if these are backed with a material that is not stable at 100 °C. PVC-backed tiles may be



processed without problems, but bitumen backings soften and distort if treated at elevated temperatures (70–90 °C depending on the particular bitumen composition used). With careful choice of carpet fibre, dyes and print paste additives (section 4.7), satisfactory dye fixation can be achieved using a saturated ‘steam’ atmosphere at lower temperatures.

4.5.3 Washing-off equipment

No dyes can be completely fixed on carpet fibres, so that residual dye, as well as the chemicals and thickening agents, must be removed at the washing-off stage. For economy cold water alone is used, in contrast to textile-printing practice. Only in the case of polyester and acrylic carpets are heated wash tanks considered. Two or three baths, preferably with countercurrent water flow, are used. Nevertheless a typical carpet-printing range requires a wash-water flow of $20\text{--}40 \times 10^3 \text{ l h}^{-1}$. To accelerate the interchange between the liquor on the carpet and the wash water, various agitator systems have been used; in addition, each exit path from the liquor should have a spray pipe and mangle squeeze or, better, an extraction slot. A particularly good effect can be achieved using perforated-drum wash units in which the liquor actually passes through both the pile and the backing of the carpet.

Occasionally, where very heavy shades are being produced, cross-staining of washed-off dye on to pale or white ground shades may occur. This can be avoided by passing the carpet through a mildly alkaline bath as it leaves the steamer. This also improves the wet fastness of the prints, as the alkali aids the removal of unfixed dye.

In yarn-printing operations, heated wash-off tanks are more commonly used, followed by spray pipes and mangle squeezing.

4.6 PHYSICAL FACTORS AFFECTING THE QUALITY OF PRINTED CARPETS

The basic mechanism of screen printing is the application of a shearing force and pressure (in a pressure wedge formed by the angle between the advancing squeegee and the screen surface) to the print paste, thus forcing it through the screen mesh and on to the carpet surface. When printing carpet, however, a further requirement is to force this paste to penetrate well down into the carpet pile, whilst maintaining an adequate degree of pattern clarity, and this poses considerable problems.

Two practical solutions to this problem involve use of a pressure differential between the surface of the applied paste and the reverse side of the carpet (using vacuum in the BDA machine, hydrostatic pressure in the Zimmer Hydroslot and Magnetjet systems). An alternative approach is to use a double roller squeegee of



relatively large diameter in place of the single rubber squeegee commonly used by textile printers. This, in effect, produces fairly wide and acute-angled colour wedges, factors which have been shown to lead to increased delivery of paste per squeegee stroke and to improved pile penetration. At the same time there is a loss of sharpness of the print, but this is quite acceptable in the context of carpet printing, where a spread of up to 3 mm is not unusual except in the finest designs. Dowds has studied the above factors in the field of textile printing [4]; in carpet printing, allowing for slower running speeds of the squeegees, coarser screen mesh and the lower paste viscosities used, it can be calculated that the shear stress is lower by a factor of about 100.

4.6.1 Flat-screen printing

Few quantitative studies of flat-screen carpet printing appear to have been undertaken but, using small-scale laboratory equipment, Dawson showed the beneficial effect of increased pressure loading on roller squeegees (simulating the magnetic rollers of the Zimmer machine) in improving pile penetration (Figure 4.8) [5]. The effect was comparable to that obtained by increasing the degree of vacuum in the BDA process (Figure 4.9) or the nip pressure in the Stalwart printing technique (Figure 4.10). Similar curves to these were obtained over a range of paste viscosities, but the sensitivity of the results to varying viscosity was not very marked in the flat-screen printing applications. Clearly, however, there is a considerable lack of detailed knowledge in this field.

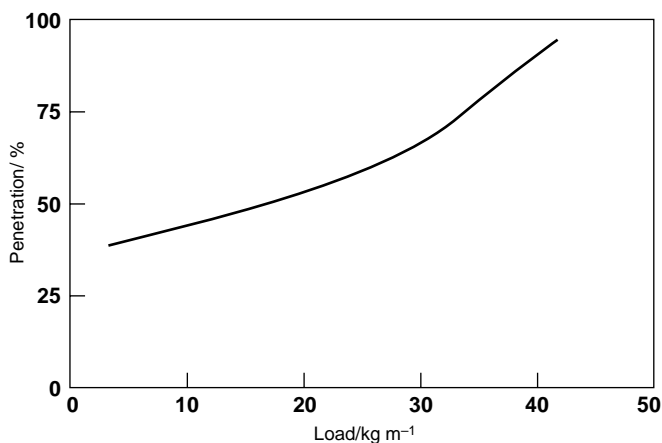

Figure 4.8 Zimmer flat-screen printing process; effect of roller squeegee pressure

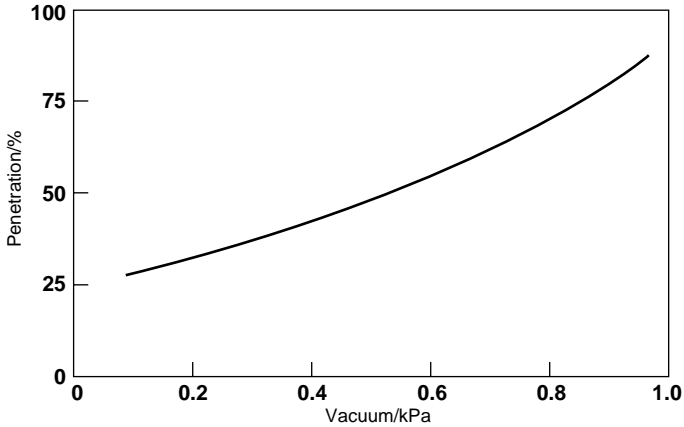

Figure 4.9 BDA flat-screen printing process; effect of vacuum applied

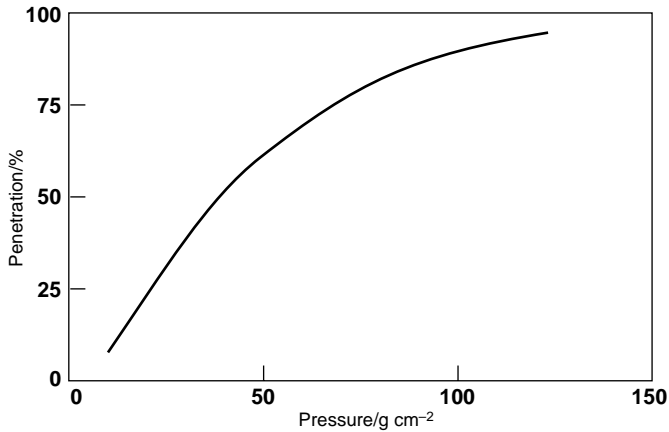

Figure 4.10 Stalwart printing process; effect of nip pressure

4.6.2 Rotary-screen printing

An extensive comparative study of the variables in the various rotary-screen printing techniques has been reported by Dunkerley and Hughes [6]. Rather than trying to relate the results obtained on bulk-scale machines, where truly comparative results cannot be attained, a laboratory machine was used on which the mechanical arrangements corresponding to each of the present rotary printing techniques could be simulated. Thus, for example, all the mechanical variables indicated in Figure 4.11 for a rotary-screen printing machine were investigated, using thickeners that differed in

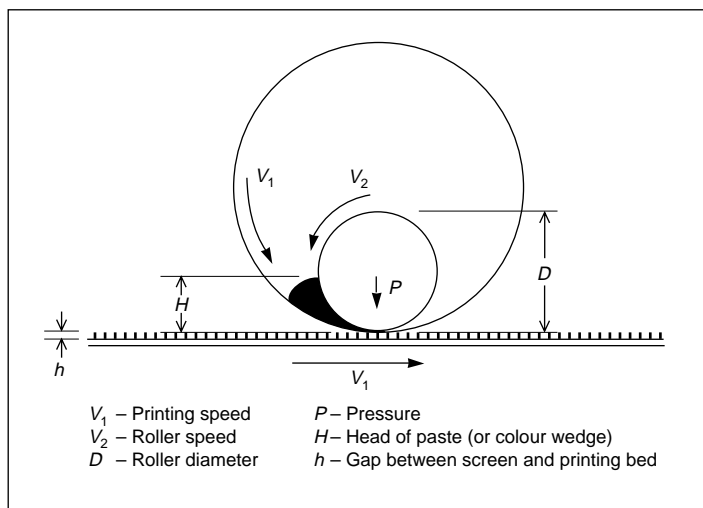

Figure 4.11 Mechanical variables of rotary-screen printing (roller squeegee)

both viscosity and rheological type. In the case of the Hydroslot squeegee system, the main variable examined was that of hydrostatic head of print paste.

The practical printer is mainly interested in attaining penetration of dye down to the base of the carpet pile without serious loss in pattern definition, but these goals are generally mutually exclusive. It is found, for example, that the most effective method of increasing pile penetration with a roller squeegee system is to increase the head of print paste behind the squeegee; however, increasing this so-called 'colour wedge' leads to paste being expressed through the screen mesh before it comes into contact with the carpet. The paste can therefore flow outside the edges of the pattern on the screen, and definition is lost. This tendency is less pronounced with the Hydroslot squeegee system (Figure 4.12), since preflooding of the screen is effectively prevented by the narrow slot in the squeegee. There is some loss of definition, however, when the hydrostatic head is increased, as there is some lateral spread of paste within the carpet pile.

In the case of roller squeegees, somewhat surprisingly, the paste viscosity has only a limited influence on pile penetration. On the other hand, print definition is improved by increasing viscosity, as might be expected. When the Hydroslot system is used, on the other hand, paste viscosity requires close control since pile penetration, definition and the amount of paste applied to the carpet (i.e. wet pick-up) are all markedly affected by this factor (Figure 4.13). The Hydroslot system is a particularly flexible one, since the desired end-results can largely be achieved by adjusting the interrelated variables of static head and viscosity. For example, similar results can be achieved by using a small static head with a high-viscosity paste, and vice versa.



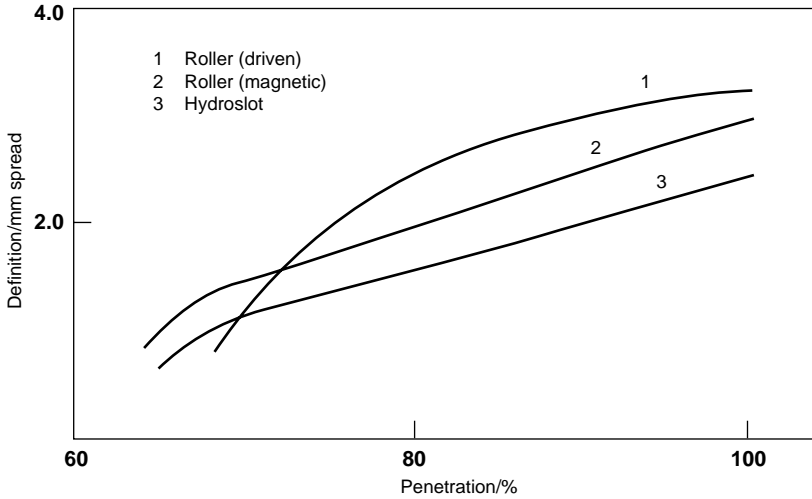

Figure 4.12 Relationship between pile penetration and definition

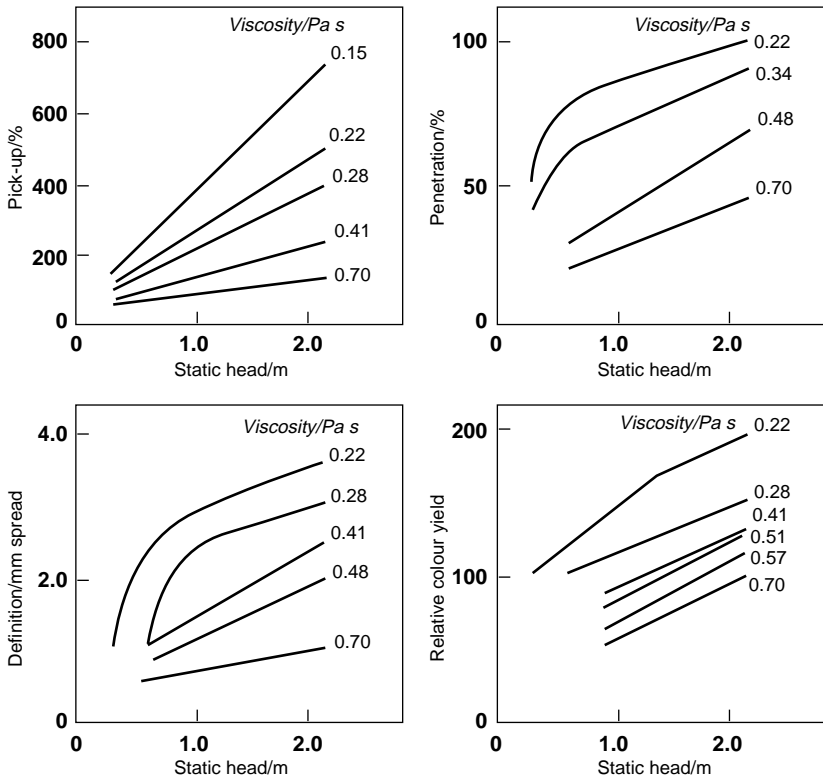

Figure 4.13 Hydroslot system; effect of viscosity

With roller squeegee systems paste viscosity has only a limited effect on the results achieved, and therefore to achieve the desired end-results other control variables must be sought. Foremost among these is that of the size of the colour wedge behind the roller squeegee. Clearly, however, the maximum size of colour wedge that can be employed will depend on the diameter of the roller squeegee. This probably explains the trend towards larger-diameter roller squeegees (up to ca. 150 mm) as the mechanics of both magnetic and driven roller systems were refined over the years. The loss in definition that normally results from the use of both large-diameter rollers and large colour wedges can fortunately be countered by the simple expedient of increasing the running speed of the machine. Higher running speeds are indeed desirable from a productivity point of view, but are limited to lightweight carpet constructions (such as low-level loop 'kitchen' carpet qualities), since insufficient paste may be delivered to the carpet surface – that is, pick-up values become undesirably low (Table 4.4). Table 4.4 also illustrates the similarity in the results with both friction and positively driven roller squeegees.

Table 4.4 Effect of increased size of roller squeegee

Roller diameter /mm	Driven (D) or magnetic (M)	Head of printing paste /mm	Printing speed /m min ⁻¹	Pick-up /%	Pile penetration /%	Definition (spread/mm)
80	M	30	7.5	120	70	3.0
80	M	40	7.5	150	80	3.0
80	M	30	15.0	120	50	2.0
80	D	30	7.5	140	70	3.0
80	D	30	15.0	120	50	1.5
160	M	30	7.5	220	95	3.5
160	M	40	7.5	210	100	4.0
160	M	30	15.0	160	85	3.0

Thus, despite the 10% circumferential speed difference between the driven roller and the screen in the case illustrated, no marked increase in pick-up or pile penetration was observed. In practice, the main advantage of positively driven roller squeegees lies in the fact that they can be so adjusted that only a slight crushing effect is exerted on the carpet pile. Little pile deformation therefore occurs during the printing process. With the magnetic squeegee system, by contrast, a minimum magnetic 'pull' on the squeegee is required to obtain a friction drive and to maintain the squeegee in position. Moreover, the greater this downward pressure the greater is the pile penetration, although this effect is not marked. Experience shows that, depending on the quality of the carpet being printed, the pressure exerted by a series of magnetic printing rollers



can adversely affect the handle and aesthetic appearance of the final carpet. The repeated 'crushing' effect is, however, beneficial in terms of improved colour penetration into the carpet pile, which may increase by as much as 40%.

Although not commonly resorted to in practice, a further method of improving print definition is that of using a finer screen mesh. Carpet-printing machines of the roller squeegee type normally employ a raster of 7–10 holes per centimetre (18–25 mesh). For fine line work (such as outlines on low-level-loop carpet), however, it is possible to use a 16 raster screen as the loss in penetration and pick-up which results from this change is acceptable for 'fall-on' effects. With the Hydroslot squeegee system, by contrast, pile penetration and print definition is less affected by changes in mesh (Table 4.5), so that finer-mesh screens could be used even for blotch prints.

Table 4.5 Effect of screen mesh

Squeegee system	Screen raster/cm ⁻¹	Pick-up /%	Pile penetration /%	Definition (spread/mm)
Roller (magnetic)	7	200	100	3.5
	16	50	30	<1.0
Roller (driven)	7	220	100	3.0
	16	50	20	<1.0
Hydroslot	7	375	100	2.5
	16	200	90	2.0

4.6.3 Jet printing

Unlike flat- and rotary-screen printing methods, jet printing is a noncontact application system and the only mechanical force that can be regulated (in order to increase pile penetration by the colour, for example) is that controlled by the volume and the pressure/velocity with which the drops of liquor can be ejected from the jet on to the carpet. In general, increasing the drop velocity improves pile penetration; but the liquor pressures that can be used in practice are limited by the desired minimum drop size (which affects print definition) and the need to avoid splashing by the drops as they impinge on the carpet surface. Further penetration of the dye into the carpet pile is then dependent on capillary action and fibre surface wetting forces.

The target definition of the jet printer (usually 10 or 20 mesh) determines the minimum size of drop that can be used (or rather the diameter of the spot produced when the drop lands on the substrate). Thus at 10 mesh the diameter of the spot



produced should be about 2.5 mm. If the drop size is now increased, the liquor penetrates into the carpet pile by capillary forces but there is a gradual lateral spread. Thus for any quality of carpet there is an optimum firing time which produces drops of such a size that they give acceptable print definition with the maximum degree of pile penetration.

Figure 4.14 gives a general indication of the relationship between firing time and liquor pressure on the pick-up values that would be obtained on carpets of different pile weights. Table 4.6 shows the effect of firing time and the liquor pressure on the degree

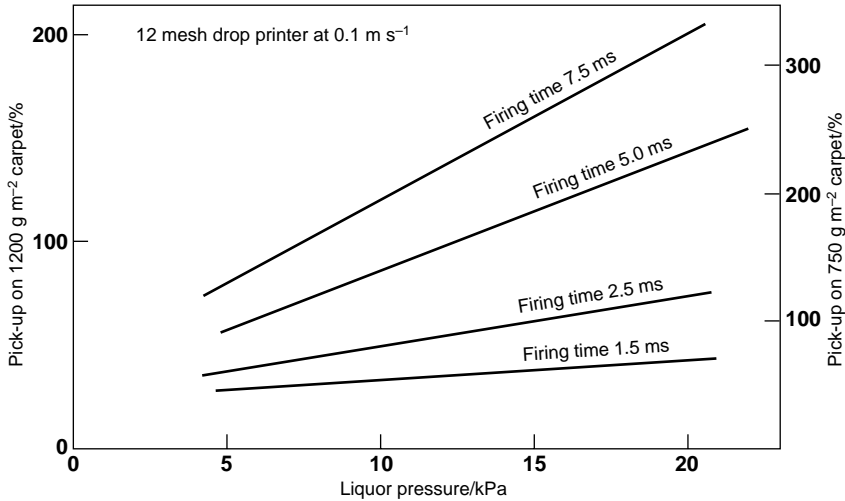

Figure 4.14 Jet printing; control of pick-up

Table 4.6 Effect of liquor pressure and firing time on print definition and pile penetration

Liquor pressure /kPa (lbf in ⁻²)	Firing time /ms	Pile penetration /%	Definition (spread/mm)
<i>Low-pressure machine</i>			
7 (10)	1.5	25	0.6
7 (10)	3.0	80	1.2
7 (10)	5.0	100	2.5
10.5 (15)	1.5	50	1.2
<i>High-pressure machine</i>			
14 (20)	0.7	30	0.5
21 (30)	0.7	60	1.0
31 (45)	0.7	80	1.5
41 (60)	0.7	100	2.0

of pile penetration by the colour compared with the increasing loss of definition by lateral spread for jet printers operating at low pressure (such as a Millitron machine) and at high pressure (such as a Chromojet machine).

4.7 SELECTION OF DYES AND CHEMICALS FOR PRINTING NYLON CARPETS

The main components of a print paste which may be used on nylon carpets include dye, acid-producing agent, solubilising agent, sequestering agent, antifrosting agent, antifoaming agent, swelling agent and thickening agent. Some agents fulfil more than one of these functions, whilst the action of others may be somewhat obscure, even though they may be described as wetting agents, lubricants, penetrating agents and so forth. Examination of practical print formulations often shows that they contain a wide variety of agents which at some time have been considered to improve some factor (possibly fortuitously) and which, as a result, have become established in use. Since all contribute to the cost, it is clearly desirable to discard any agent which shows no demonstrable beneficial action, and to use multipurpose agents wherever possible, thereby operating with the simplest possible formulation.

The selection and application of dyes, auxiliary products and thickening agents will now be considered in more detail. With the exception of thickening agents, the printing technique employed does not affect the selection of the various print paste components unless they have a deleterious effect on the materials of construction (for example, solvents used as fibre-swelling agents may attack screen lacquers).

4.7.1 Thickening agents

Owing to the very high consumption of paste in carpet printing (the average machine requires 2500 l h^{-1}), thickeners must be relatively cheap and possess rapid dispersion and dissolving properties in cold water. As in other printing applications, they must be stable to the other components of the paste (such as acids, dyes and auxiliary products) but, since carpet prints are steamed without intermediate drying, the thickened paste must maintain a reasonable viscosity at $100 \text{ }^\circ\text{C}$ to prevent flushing. Furthermore, as only a continuous cold-water rinse is used to wash the carpet after steaming, the thickener must be readily removable under these conditions. These criteria are met by modified locust bean or guar gums, while starch types and xanthan gums are also used to some extent. Low-solids, high-viscosity products are preferred and, for purely economic reasons, modified guar gums are particularly popular. The rheological properties of these thickeners vary somewhat, particularly with regard to their property of so-called pseudoplastic flow, that is, a tendency to decrease in viscosity with



increasing applied shearing forces (section 7.7.3). This effect can have an effect on print quality (pile penetration, pattern definition and so on).

Figure 4.15 illustrates the behaviour of three types of thickener: a 'long' thickener Indalca PA1 (hydroxyethylated locust bean gum), a 'medium' thickener Prisulon E3 (depolymerised guar gum) and a 'short' thickener Kelzan (xanthan gum). These curves emphasise the practical importance of quoting viscosity values at a particular shear rate. Commercial viscometers give reliable values over only limited shear rates, and care must be taken in comparing results from different instruments. The range of viscosities required in the various print applications for carpets is very wide, ranging from about 50 mPa s (centipoise) at a shear rate of 50 s^{-1} for warp-printing to some 5 Pa s (5000 centipoise) for certain rotary printing techniques. The short thickenings tend to be favoured for space-dyeing and jet-printing applications, whilst those of intermediate flow properties are now widely accepted for screen-printing applications.

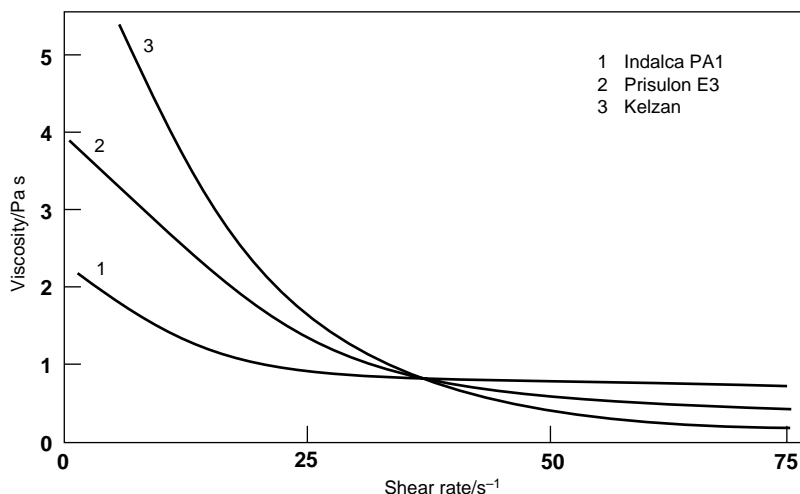

Figure 4.15 Relationship between viscosity and shear rate

4.7.2 Chemicals and auxiliary products

The rate of fixation of dyes on nylon is controlled by the pH during steaming: the lower the pH, the more rapid is the fixation. A wide variety of acid-producing agents has been suggested from time to time ranging from acid-producing salts (such as ammonium sulphate, ammonium dihydrogenphosphate and ammonium tartrate) to organic acids of varying strength (such as acetic, glycollic, formic and citric acids, which increase in strength in this order). Not all of these acids produce constant pH during the steam fixation stage, however, owing to their steam volatility. This is

especially the case when acetic or formic acid is used. Table 4.7 shows the effect of steaming a series of prints on the pH of extracts and, from this data, the variable conditions (depending on the steaming conditions) which are likely to result from the use of volatile acids are evident. Such variations can lead to end-to-end or side-to-side variations in dye yield, particularly when applying the slower-fixing dyes, the fixation of which is pH-sensitive. The use of volatile acids also leads to increased corrosion problems within the steamer. Thus the potential advantages of using the nonvolatile acids outweigh their higher cost; the most economical are usually citric acid or the by-product acid from nylon 6.6 manufacture (a mixture of adipic acid homologues). Even stronger acids, such as oxalic or sulphamic acids, are used occasionally.

Table 4.7 Stability of print paste pH during steaming^a

Agent used (10 g l ⁻¹)	pH of aqueous extract	
	Before steaming	After steaming
None	6.7–6.9	6.7–6.9
Ammonium sulphate	6.9	4.8–6.3
Ammonium tartrate	7.0	4.7–5.1
Acetic acid (80%)	4.0	6.3–6.5
Formic acid (90%)	3.6	3.9–5.6
Tartaric acid	2.9	3.0–3.4
Citric acid	2.6	2.8–3.1
Sulphamic acid	1.8	2.2–2.5

a Steaming for 10 min at 105 °C

The necessity for maintaining a constant low pH throughout the steaming process is illustrated in Figure 4.16, which shows the effect of pH on the fixation of four different types of dye within the pH range 3–7. Monosulphonated equalising acid dyes are much less sensitive to pH variations than are disulphonates, but rather surprisingly, mono- and di-sulphonated metal-complex and milling acid dyes also show the effect. Thus using an acid which gives a constant low pH enables the carpet printer to select dyes from a wider range of products than if a weaker acid or acid-producing salt were used. (The weaker acids and acid salts are, of course, used by the conventional textile printer, who dries the goods and afterwards steams them for 30 min or more.)

The addition of the acids necessary to attain rapid dye fixation tends to reduce the solubility of the dyes, and a solubilising agent may be required. This may also be the



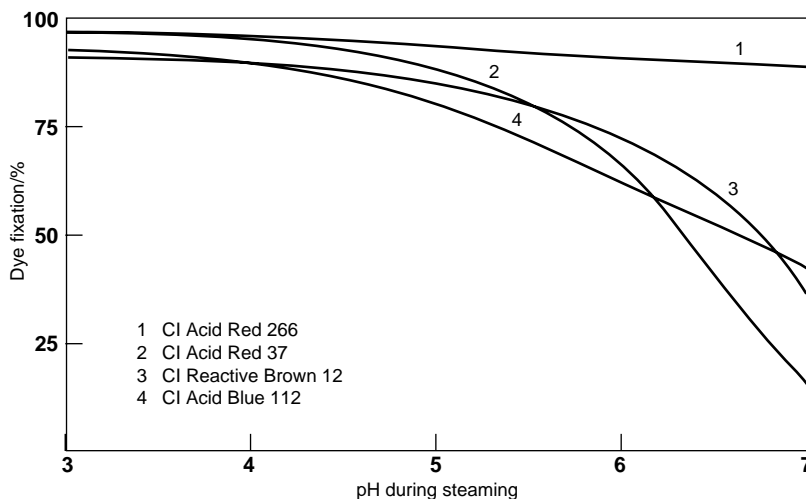

Figure 4.16 Effect of pH during steaming on dye fixation

case where a particular depth or fastness criterion is to be met. In practice, however, solubilising agents are not commonly used. This is because the dyes selected have high solubility in cold water, and the antifrosting agents often added to the print paste (discussed below) also act as solubilising or dispersing agents. Moreover, there is less need for such products in carpet printing than in textile printing, since prints are steamed without predrying. Where it is necessary to use solubilising assistants, thiodiglycol is the one most commonly chosen. Other, less water-soluble, organic solvents, such as benzyl alcohol or chlorphenoxyethanol, are sometimes used; their precise mode of action is not clear, but they appear to assist the rate of dye fixation by swelling the nylon and/or by forming a more highly concentrated dye solution on the fibre surface. As in all dyeing processes, the time required for fixation increases with increasing dye concentration, and it is therefore in heavy depths where the effect of the addition of solvents to the print paste is most marked (Table 4.8).

There is a general tendency in an impregnate–steam dyeing process on nylon carpets to obtain an effect called ‘frostiness’, whereby some of the fibres on the surface are less heavily dyed than the surrounding material, or are even undyed. The effect is caused by the lack of a continuous film of dye liquor or print paste on each individual fibre at the steam fixation stage. When the print paste is applied to the carpet and wetting is complete, a continuous film of liquor will be formed, but some degree of frostiness may result if anything interferes with this wetting action (for example, an unsuitable spin finish, a fluorocarbon antisoil finish on the yarn or silicone lubricants which can migrate into the pile from certain types of backing materials). Even when



Table 4.8 Effect of solvent on dye fixation^a

Concn of CI Acid Red 57 /g kg ⁻¹	Fixation after steaming/%	
	No solvent	With 30 g kg ⁻¹ benzyl alcohol
5	99	99
10	91	97
15	75	90
20	60	78

a Print on nylon 6.6, 200% pick-up, steamed for 3 min

the initial wetting is complete, subsequent mechanical pressure on the fibre bundles (such as the pressure exerted when a carpet passes under a succession of roller squeegees) can leave surface fibres denuded of dye liquor. Frostiness may also be introduced during steaming and this effect is usually ascribed to the condensation of steam on the cold carpet entering the steamer, causing some dye to be flushed away from surface fibres.

In order to overcome these effects it is usual to employ surface-active products known as antifrosting agents. These act as wetting agents, film-formers and foaming agents during the steaming stage, thus forming a continuous, elastic film of dye liquor over the fibres during the printing stage and subsequently forming a viscous foam during the initial stages of the steaming process. Even when antifrosting agents are employed frostiness may not be completely avoided, as long-pile carpet constructions of low pile density and the use of round-filament yarns, rather than those of the more usual trilobal cross-section, tends to aggravate the defect.

Typical antifrosting agents are based either on nonionic fatty acid amides and ethoxylates, or on anionic products such as sulphonated alcohols or sulphosuccinate esters. Apart from the antifrosting mechanisms described above, they may also form complexes with the dyes used and may thereby affect their solubility and fixation characteristics. Since the agents are surface-active, they tend to foam when mechanically agitated and this may cause problems at the dye application stage. The use of antifoams is therefore quite common, but opinions are divided on whether agents of the ethylcyclohexanol type or silicone products are preferable. Both types are, in fact, capable of working satisfactorily, but the silicone antifoams require closer control, as excessive concentrations suppress the formation of foam at the steam-fixation stage and frosty effects may reappear.



4.7.3 Dye selection

Nylon may be printed with acid dyes and also with a few direct dyes, which can be fixed on the fibre without intermediate drying by steaming for 3–10 min. A very wide range of such dyes is available so that selection on the basis of many factors is possible. Apart from selection on the basis of fastness properties, the chief amongst these factors are solubility, fixation and wash-off characteristics.

The acid dyes that can be used for printing nylon fall into two main groups, with advantages and disadvantages as described in Table 4.9. The fixation and fibre penetration characteristics are governed by the molecular size and shape and the degree of polarity of the dye concerned. Typical dye fixation curves are shown in Figure 4.17, in which the very rapid fixation of an equalising acid dye is contrasted with that

Table 4.9 Dyes for printing nylon

Dye type	Advantages	Disadvantages
Equalising acid	Very rapid fixation Very rapid penetration Usually economical Fixation not pH-sensitive Good coverage of irregular nylon	Limited wet fastness in deep depths
Milling acid and metal-complex	Very good wet fastness Best dyes for deep shades if longer steaming times are possible	Slower fixation Inferior fibre penetration Tendency to frostiness Less reproducible

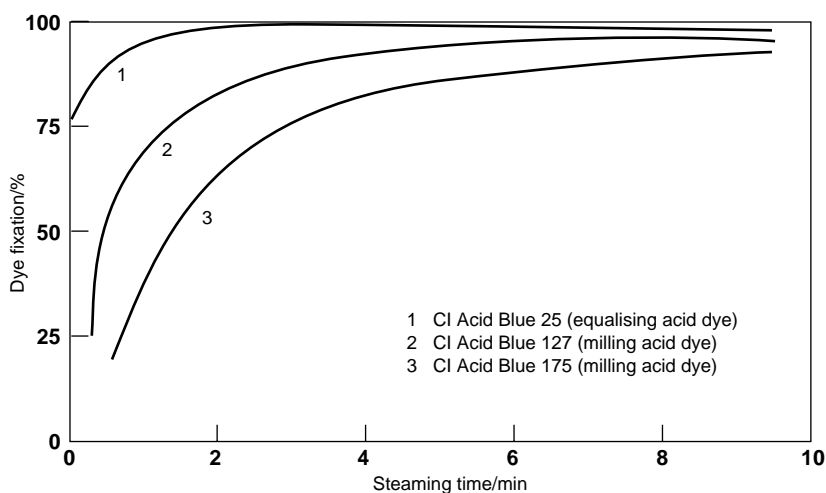

Figure 4.17 Dye fixation on nylon 6.6



of two milling acid dyes. In practice it is desirable for the dye to reach an equilibrium fixation value by the end of the steaming process. Thus, of the three dyes illustrated in Figure 4.17, only one would be fully satisfactory if fixed on nylon 6.6 by steaming for, say, 4 min. The fixation of any dye is, however, considerably faster on nylon 6, particularly if the yarn has been heat-set, the equilibrium fixation levels being achieved in approximately half the steaming time required on nylon 6.6.

The lower rate of fixation of dyes with larger molecules probably arises from their tendency to form aggregated solutions, as well as from their inferior rate of diffusion from the surface to within the fibre. The difference in fibre diffusion rates can be readily observed from cross-sections of nylon carpet yarns after dye fixation has proceeded for various times (Figure 4.18). The inferior penetration characteristics of the milling acid and metal-complex dyes can lead to problems with reproducibility. This is because, although a high level of fixation is achieved, increasing fibre penetration leads to increasing visual colour yield. Thus if there is any variation in steaming time (for example, if goods have been left in the steamer for longer than usual due to a stoppage) a difference in colour will be observed. Furthermore, if short steaming times (2–3 min) are used, the presence of ring-dyed nylon fibres in the carpet can give rise to ‘abrasion frostiness’ when used in areas of high surface wear, such as doorways. This problem was formerly associated mainly with the warp-printing

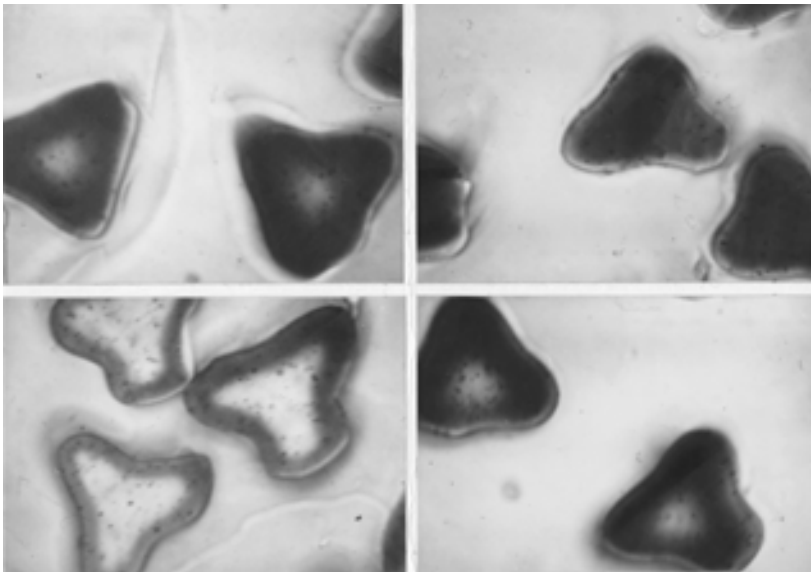

Figure 4.18 Diffusion of dyes into nylon carpet fibre; top – CI Acid Red 266, bottom – CI Direct Red 81 after 2 min (left) and 10 min (right) steaming

process, as the steamers used for both carpet and knit–deknit yarn-printing processes usually allow longer steaming times.

Problems of dye compatibility do not generally arise in printing, although dye separation between the top and the base of the carpet pile, or at the edge of a printed area, can sometimes occur. This is due to one dye of high affinity temporarily blocking the dye sites on the surface of the fibre, so that the dye of lower affinity and slower fixation characteristics migrates beyond the original print area. In knit–deknit space dyeing, the high-affinity dye will also remain on the surface of the knitting stitches, whilst the slower-fixing dye penetrates further into the sock. This is one reason why it is sometimes difficult to change space-dyeing recipes without at the same time altering the character of the final effect.

In general, dye fixation on nylon is efficient, 90–95% fixation being usually achieved. Nevertheless some unfixed dye remains, and needs to be washed off using copious quantities of cold water. Usually this presents no problem but, since fixation efficiency decreases with increasing concentration of applied dye, problems of staining of unprinted areas or of pale grounds can arise with dark colours. The staining properties of the individual dyes vary considerably and no single class of dye is superior to another. When the problem does arise, therefore, it is necessary to examine the dyes in use, and establish a maximum concentration at which each gives an acceptable degree of cross-staining under the particular washing-off conditions employed. The addition of sodium carbonate or of certain cationic ethoxylates to the wash liquor will also reduce the tendency to stain back by reducing the affinity of the dye for the fibre.

In order to increase the variety of effects that can be obtained by the various printing techniques, it is sometimes necessary to be more selective with the dyes employed. This is the case where resist printing effects (see section 4.7.4) are produced as well as for direct printing on differential-dyeing nylon fibres. Resist printing may be attractive for various reasons:

- for flexibility, where dyeing as well as printing equipment is available, as a ‘latent’ pattern can be printed on carpet piece or yarn with colourless resist agents and a variety of coloured effects then subsequently produced by piece dyeing
- where the printing equipment is suitable for overprinting on coloured grounds (the Stalwart machine, for instance), but not for printing ‘fitting’ designs
- to ensure that patterns having large areas of one ground shade appear with the optimum degree of levelness.

4.7.4 Products for discharge, resist and displacement printing

In a constant search for novelty the carpet-printing trade has developed a wide variety of processes in which the applied dyes are selectively discharged or resisted by chemical



means, or physically displaced from the carpet surface. Physical displacement was the basis for the Gum-TAK process developed in the USA (see section 4.3.4) using liquors and print pastes that differed in their viscosity.

Normal discharge printing methods using, for example, an acidic paste containing either sodium formaldehyde sulfoxylate or thiourea dioxide have been used to produce white printed effects on coloured ground shades. The ground may be applied to the carpet but not fixed, or a predyed ground may be used. The former process is more successful since the discharge agent can more readily reduce dye that has not diffused into the fibre. Experience has shown, however, that the quality and sharpness of the discharge are difficult to control and reproducibility is poor. 'Illuminated' discharges can be produced by incorporating a discharge-resistant acid dye into the discharge recipe, but it is difficult to find suitable blue dyes for this purpose.

Resist styles have enjoyed much greater commercial success, although there is often a degree of mechanical displacement as well as a chemical resist effect in these processes. Three types of resist agent have been used:

- reactive agents that permanently alter the affinity of the fibre for acid dyes (for example, Sandospace S and DP (S))
- substantive, anionic agents which tend to prevent fixation of dyes having lower neutral affinity or those of large molecular mass, that is, slower-diffusing dyes (for example, Thiotan SWN (S), Matexil FA-SNX (Zeneca), Mesitol NBS (BAY))
- cationic agents that tend to form complexes with dyes of large molecular mass, such as 1:2 metal-complex and milling acid dyes (for example, Basacryl Salt KX (BASF), Thiotan TR (S)).

There are many possible application sequences, and each printer chooses the one most suited to the equipment available (the printer and dye applicator systems). Types of dye used for these processes are:

Type A: monosulphonated equalising acid dyes

Type B: 1:2 metal-complex dyes (both mono- and di-sulphonates) or selected milling acid dyes

Type C: disulphonated equalising acid dyes (high-contrast dyes)

Type D: reactive wool dyes, such as Drimalan F (S)).

In general ground shades are applied using thickeners that suffer a considerable loss of viscosity during steaming (such as modified locust bean gums), as these assist penetration of the ground shade into the pile and enhance the resist effect. Too much drainage during steaming can lead to 'frostiness' in the ground shade, but this can be controlled by adding a small amount of a thermally stable thickener such as a xanthan gum. Xanthan gums are also suitable for the printed resist operation.



The pH of the ground shade liquor and the overprint paste must be controlled for reproducible effects. Typically the pad liquor is at pH 4–5 and the illuminating overprint at pH 6–8. For white resist effects the displacement of the ground shade can be further enhanced by using an alkaline (pH 9) overprint.

4.8 PRINTING OF CARPETS TUFTED FROM FIBRES OTHER THAN NYLON

Although nylon meets most of the criteria of a good carpet fibre, wool, viscose rayon, acrylic, polyester and polypropylene fibres have also been used. Each has its own attractions, such as cheapness, appearance, freedom from static problems or even mere novelty.

4.8.1 Viscose

Viscose was, in fact, the main fibre used during the early development of carpet printing and, although in the past cheap one- or two-colour overprinted viscose rayon carpets enjoyed a long commercial success in the UK, they are now of little importance (Table 4.10). The printing technique used was very simple, since many direct dyes can be fixed by steaming for 5–10 min. In the case of Stalwart machine printing (using no thickener), the prints had sufficiently good fastness properties without any washing-off treatment being given.

4.8.2 Wool

Wool has significantly increased its importance as a fibre for tufted carpets, but only a

Table 4.10 Individual fibre share of UK tufted carpet market

Fibre	Share (by area)/%		
	1970	1980	1990
Viscose	60	7	1
Nylon	20	64	46
Acrylic	17	4	2
Wool	2	6	17
Polypropylene	0.5	16	31
Polyester	0.5	3	3



few printed qualities have appeared on the market. A wide range of acid dyes can be fixed on wool by steaming for about 10 min. Blends of wool/nylon, used where superior abrasion resistance is desired, can usually be printed with the same dyes, as there are no problems of unequal dye partition between the two fibres (which are common in batchwise dyeing processes). On the other hand, the appearance of the printed carpet shows a considerable dependence on the quality of the wool used and the finer worsted-spun, chemically set yarns of good whiteness are preferred to the normal coarser woollen-spuns. The main objection to the use of wool is the cost of the fibre content of the final carpet; on the other hand, the appearance and feel of wool fibre is an important sales criterion in a market accustomed to Wilton and Axminster carpets.

4.8.3 Acrylic fibre

At one time the use of acrylic fibre offered the nearest approach in appearance and handle to wool carpets. Unfortunately the handling of acrylic carpets in piece form can be troublesome, owing to the thermoplastic nature of this fibre. Thus, after steaming, a gradual decrease in temperature rather than the 'thermal shock' of the conventional cold water wash-off is required. It may also be necessary to use special heat-finishing treatments to improve pile appearance. Modified basic dyes are employed for printing acrylic fibres and, although there is a wide range of products which give good fixation and fastness properties after steam fixation for 5–10 min, problems can arise in deep shades. The rate of fixation of modified basic dyes printed on acrylic fibre depends on their rate of diffusion into the fibre, which is not directly related to the Compatibility Values (CV or Beckman K factor) of the dyes. Thus although in batchwise dyeing applications CV 1.5 dyes exhaust more rapidly than CV 3 or 5 dyes, this is not the case in printing applications. It is, however, necessary to select dyes of similar CV to avoid incompatibility problems (colour variations within the carpet pile). The rate of fixation is further affected by the degree of fibre saturation attained at any particular depth, which depends on the individual acrylic fibre and dye(s) used. Even with the best dyes, when printing on standard acrylic fibres, it is necessary to use a swelling agent to achieve optimum fixation levels in short steaming times. Various solvents are suitable for this purpose, including γ -butyrolactone, ethylene or propylene carbonate or chlorphenoxyethanol.

4.8.4 Polypropylene

Unmodified polypropylene fibre has been used for carpets (more particularly needlefelt floor coverings) for many years, but because it cannot easily be dyed or printed mass



coloration methods have been used. This led to the development of modified polypropylene fibres which could be coloured using disperse, acid or special chelating dyes. For carpet printing and space dyeing a nickel-modified polypropylene has been used. This can be printed with special disperse dyes which contain chelating groups that form a complex with the nickel contained in the fibre. This fibre type is still used for space dyeing. Forms of polypropylene that can be dyed with acid dyes have recently been introduced for printing, but problems still arise in achieving good levels of both light fastness and wet fastness.

Despite these difficulties polypropylene is taking a greater share of the carpet fibre market (Table 4.10) and at the moment most of the fibre used is either mass-pigmented or undyed (being used as an intermingled yarn or fibre blend together with nylon, which can be dyed by conventional methods). The main reasons for the gain in market share of this fibre are its low cost and good all-round performance, together with the fact that larger firms can install relatively cheap fibre-spinning plant and produce the required carpet yarns in-house.

4.8.5 Polyester

The use of polyester in carpets has never been extensive, despite earlier long-term forecasts that this fibre would become increasingly attractive economically as compared with nylon. This advantage is at present rather offset by a higher cost of coloration and the need to employ higher pile weights of polyester to achieve wear performance standards comparable with those of nylon. Polyester has an advantage over nylon in appearance retention when heat-set, so that it has found most use in longer pile Saxony and shag-type carpets, particularly in the USA. Printed Saxonies have been particularly popular in some markets but these are mainly of nylon, owing to problems associated with printing unmodified polyester fibres. The latter must be printed with disperse dyes and, although dye fixation can be achieved by steaming for 10–15 min in the presence of a dye carrier such as *o*-phenylphenol, it is necessary to give a hot soaping aftertreatment to achieve adequate rub fastness of the prints. But with the advent of modified polyester carpet fibres (both ‘deep dyeing’ so-called disperse-dyeable and basic-dyeable types), polyester carpet has become more attractive. With these modified fibres it is possible to obtain good fixation of both disperse and modified basic dyes under normal steaming conditions without having to use either a dye carrier or an aftersoaping treatment. Examples of modified polyester carpet fibres are the extensive Trevira 800 series produced by Hoechst.



REFERENCES

1. D T Ward, *Tufting: an introduction* (Manchester: Textile Business Trade Press, 1969).
2. H Robinson, *Carpets* (London: Trinity Press, 1972).
3. H Pointon, *Carpet surfaces* (London, Textile Trade Press, 1975).
4. B F Dowds, *J.S.D.C.*, **86** (1970) 512.
5. T L Dawson, *Text. Chem. Colorist*, **2** (1970) 273.
6. K Dunkerley and J A Hughes, *J.S.D.C.*, **91** (1975) 265, 377.

FURTHER READING ON MACHINERY

- J Wirtz, *Bayer Farben Rev.*, **30** (1978) 47.
K Dunkerley, *Rev. Prog. Coloration*, **11** (1981) 74.
T L Dawson, *Rev. Prog. Coloration*, **22** (1992) 22.



Contents



Home

CHAPTER 5

Direct print coloration

Heinz Gutjahr and Robert R Koch

5.1 INTRODUCTION

Printing can be considered as a controlled form of localised dyeing and, in principle, any dyes used to produce plain-coloured fabric could be used to print that fabric. The same mechanisms of dye fixation apply in both dyeing and printing. Careful selection of appropriate dyes for a particular dyeing process is desirable, however, and selection for printing is essential. The primary reason is that in printing dye solubility is more critical, even more so than for continuous dyeing processes, which admittedly compare closely with printing. Not only is the amount of water in the print paste severely limited but, at the fixation stage, the dye must be redissolved in a small volume of condensed steam. (Fixation and other aftertreatment processes are fully discussed in Chapter 8.)

There are further reasons for careful selection. The dye must diffuse through the film of thickener before adsorption on, and diffusion into, the fibre. Unless the dye diffuses rapidly, therefore, the fixation time must be extended. Consequently the lower-r.m.m. dyes will often be preferred, provided that their fastness levels are adequate. It is also necessary to choose dyes that can be washed off satisfactorily, without staining the ground or other printed areas in the fabric.

Not only must the dye manufacturer select the dyes that show satisfactory printing properties, but when one dye is recommended for both dyeing and printing the standardisation will be different. For example, lower electrolyte content is desirable for printing, especially where electrolyte-sensitive thickening agents are used.

In this chapter, therefore, the factors that determine the selection of colorants for particular fabrics and fixation methods are considered. The term 'colorant' is used here because it covers both dyes and pigments.

Pigments, of course, are used for the production of plain-coloured fabrics, but are of much greater importance in printing. The principal reason is that the stiffening effect of the pigment binder is less noticeable where significant areas of fabric are left



uncoloured and flexible. For this reason, a far higher proportion of low-cover designs are printed with pigments than of high-cover prints. Secondly, and perhaps equally importantly, the elimination of the washing-off stage has extra value to the printer because this is a more critical operation for prints than for plain-dyed fabric. Thirdly, rub marking, to which pigment prints are susceptible, is more objectionable on dyed fabrics than on prints, where the pattern conveniently distracts the eye.

Because pigments can be applied to all textile fibres, including glass fibre for which there is no alternative, and because pigments are used more than any other colorant type, pigment printing is here considered first.

5.2 PIGMENT PRINTING

In pigment printing, insoluble pigments, which have no affinity for the fibre, are fixed on to the textile with binding agents in the pattern required. This description is perhaps oversimplified, but it does obviously set pigments apart from dyes that are absorbed into the fibre and fixed there as a result of reactions specific to the dye.

The economic importance of pigments in printing is substantial: since around 1960 these have become the largest colorant group for textile prints. More than 50% of all textile prints are printed by this method, mainly because it is the cheapest and simplest printing method. After drying and fixation, these prints meet the requirements of the market. The washing process, carried out on classical prints to remove unfixed dye, thickening agents and auxiliaries, is not normally necessary when using the pigment printing technique.

For more than 3000 years, mineral pigments have been ground with natural binding agents (drying and boiled oils, or viscous, aqueous solutions of albumen products and vegetable gums) and 'applied' to the textile to form a pattern. Even though pigment printing is the oldest printing method, it was unimportant until the Second World War because of the poor results of the technique: dull colours, loss of textile character as a result of hardening, and poor fastness to wear and washing.

The basic products for modern pigment printing were available quite early, but the techniques required development. In the 1920s dispersions of useful organic pigments like those found in pigment printing today were available on the market; Hansa Yellow pigment pastes were an example. In the 1930s emulsion copolymerisation of olefinic substances (such as butadiene, vinyl esters, acrylonitrile and acrylic acid esters) was discovered at the former IG Farben in Leverkusen and Ludwigshafen. These were integral steps in the development of modern pigment printing. Another important step was the introduction of emulsions as printing paste thickeners. In 1937 the first pigment printing pastes based on water-in-oil (w/o) emulsions were developed in the



USA by Interchemical Corporation. In the following years these emulsions were often used on the American continent – even as late as the 1960s – for cheap staple goods with modest fastness requirements.

These water-in-oil emulsion pigment pastes were not accepted by the European market, where fastness properties were of more importance. In Europe aqueous pigment systems, for use in oil-in-water emulsions, were developed. The o/w emulsions ultimately drove out the w/o emulsion-based systems, even in the USA [1,2]. Eventually, synthetic thickeners became available.

A good-quality pigment print is characterised by:

- brilliance and high colour value relative to the pigment concentration in the paste
- minimum stiffening in the handle of the textile
- generally acceptable fastness properties.

The currently available ISO-approved methods for fastness testing and evaluation of prints do not take into account the mechanical effect on pigmented binder films during washing, and do not adequately reproduce the mechanical action of washing in a household machine. In practice, additional tests have proved successful in judging fastness properties, tests of resistance to scrubbing under defined conditions being particularly important.

Successful pigment printing systems are based upon three equally important components:

- pigment dispersions
- binders and crosslinking agents
- thickeners and auxiliary agents giving the required rheology.

5.2.1 Pigment dispersions

Most of the pigments used in textile printing are synthetic organic materials, except for carbon black, titanium dioxide of the rutile and anatase types (for white pigments), copper and aluminium alloys (for metallic bronze pigments), and sometimes iron oxide (for browns) and titanium dioxide coated glimmer (for pearl lustre pigments). When choosing synthetic pigments, the price, the fastness properties, the brilliance and the colouring power of the many products available are all taken into consideration.

Among the organic pigments in use, the following are important:

- azo pigments (yellows, oranges, reds)
- naphthalene, perylenetetracarboxylic acid, anthraquinone, dioxazine and quinacridone pigments (very fast and brilliant oranges, reds and violets)
- halogenated copper phthalocyanine derivatives (blues and greens).



Examples include:

- CI Pigment Yellow 81 (disazo, arylamide), bright greenish yellow
- CI Pigment Yellow 83 (disazo, arylamide), reddish yellow
- CI Pigment Orange 13 (disazo, pyrazolone), orange
- CI Pigment Red 7 (monoazo), neutral red
- CI Pigment Red 122 (quinacridone), bright bluish red
- CI Pigment Green 7 (perchlorinated copper phthalocyanine), bright green
- CI Pigment Blue 60 (anthraquinone), navy blue
- CI Pigment Violet 23 (dioxazine), bluish violet.

The chosen pigments are treated in a disintegrator or grinding mill in the presence of suitable surfactants until they have been reduced to the optimum particle size – in the region of 0.03–0.5 μm . If the pigment is not fine enough, the prints are dull and grey: a particle size of less than the wavelength of visible light, however, results in a loss of covering power and colour intensity.

With aqueous pigment pastes, the dispersion medium is of course water. The surfactants used must have an HLB value (see section 7.4) >10 ; nonionic dispersing agents based on ethylene oxide condensates with C_{12} to C_{20} alcohols are commonly used. When producing a pigment paste starting from a wet press-cake that contains about 25% pigment mixed with water, it is only possible to make about 20% pigment dispersions. Highly concentrated pigment pastes (with 35–45% pigment content) are obtained from dried press-cake; the drying conditions for this must be as mild as possible, in order to avoid formation of hard pigment agglomerates.

Water-free pigment pastes (for w/o emulsion pastes) were produced from aqueous pigment press-cakes by using the ‘flushing’ process, which is usually employed in paint production. The press-cake is worked with a solution of selected polyester resins in suitable hydrocarbons in a container known as a ‘flusher’, equipped with efficient kneading and stirring apparatus, until the pigment is finely dispersed and has completely passed over into the hydrophobic phase. The water in the press-cake is almost completely separated and can be removed. Binding agents, based on the condensation of maleic anhydride, saturated and unsaturated fatty acids and polyols, are added; they also act as dispersing agents.

5.2.2 Binder systems

The binder film in a pigment print is a three-dimensional structure, the third dimension of which is of rather less importance than the other two. The binder is a film-forming substance made up of long-chain macromolecules which, when applied to the textile together with the pigment, produce a three-dimensionally linked network.



The links are formed during some suitable 'fixing' process, which usually consists of dry heat and a change in pH value, bringing about either self-crosslinking or reaction with suitable crosslinking agents.

The degree of crosslinking should be limited, to prevent the macromolecules becoming too rigidly bonded, thus preserving some extensibility. The important criteria, which ensure that the pigment within the crosslinked binder film is fast to wear and cleaning, are elasticity, cohesion and adhesion to the substrate, resistance to hydrolysis, as little thermoplasticity as possible and absence of swelling in the presence of dry-cleaning solvents. The binders used are all addition polymers, preferably copolymers such as structure 5.1.

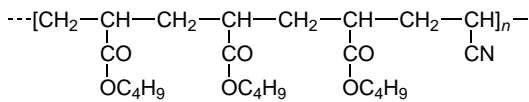

5.1

The technique used is that of emulsion copolymerisation, which leads to a product containing 40–45% binder dispersed in water. These 'dispersion binders' look like milk, are comparatively readily produced, and can be easily transported for use. Moreover, they have the advantage of high concentrations of active binding substances, together with low flammability because they contain no organic solvents. Depending upon the properties required in the binding film (softness, elasticity, plasticity, solvent stability, light and weather fastness), binders can be 'tailor-made' by choosing suitable base products [3,4]. Typically, unsaturated monomers are used, such as vinyl chloride, dichloroethene, acrylic acid, methacrylic acid, acrylamide, acrylonitrile, acrylic acid esters, vinyl ethers and vinyl esters, styrene and diolefins like butadiene.

The monomers are dispersed by using sufficient amounts of suitable surfactants, and polymerisation is initiated by means of free radicals originating from redox reactions such as that between potassium persulphate and sodium bisulphite. These add to the monomers, producing more radicals that also have the capacity to accumulate monomers. As a result of this reaction, macromolecules in chain form are produced. Their growth is limited either by the combination or disproportionation of two radicals, or by chain transfer to a monomer or to another macromolecule to give branching. The addition of 'regulating' substances can influence, if necessary, the length of the polymer chain, in order to give the required properties to the end-product or to prevent premature crosslinking. The size of dispersed polymer particles is determined for the most part by the type and amount of surfactant present during



polymerisation, and in the case of mechanically stable dispersion binders is in the region of 120–300 nm.

While the prints are being dried, a film is formed from the dispersed binder. Its formation takes place in two stages: flocculation (or coagulation) and coalescence.

During the first stage of film formation, water and surfactants are removed from the binder by absorption and evaporation. The dispersed solids coagulate to form a gel-like layer of very tightly packed ‘balls’, which have only poor solidity and adhesive properties. If the mechanically more stable, more redispersible, dispersion binders are used, these coagulated particles can be brought back to their original form by rubbing them with water.

During the second phase, the gel particles flow together to form a continuous film. The lowest temperature at which a film can be formed depends upon chemical constitution, but for pigment printing it is usually around 5 °C. The speed at which the film is formed depends upon the range of particle size. Poly(butyl acrylate), for instance, can form a film at 0 °C, whereas the more polar polyacrylonitrile is a very poor film-former even at high temperatures. For pigment printing, such a film would require to be softened by copolymerisation with, for example, butyl acrylate, in a ratio of butyl acrylate:acrylonitrile in the range 3:1–5:1. The higher the ratio the softer the film becomes, but at the same time it becomes more thermoplastic and develops poorer fastness to dry cleaning.

Binder systems for w/o pigment printing have been based on the reaction products of polyols with saturated and unsaturated mono- and di-carboxylic acids, combined with the hydrophobic butyl ethers of urea- or melamine-formaldehyde condensates. More recently, emulsion copolymers based on butadiene have been added to improve the dry-rubbing fastness of the prints.

Binders can also be made from high-r.m.m. polyols (mainly based on polyethers) and di- or tri-isocyanates. The polyurethanes thus obtained produce a soft, elastic binder film with excellent binding powers and fastness properties, but the printing pastes have to be water-free. These have a very short pot-life and are of interest to the textile printer only for special articles, since in general there is a preference for printing pastes that present no problems when applied and which can be stored for a long period of time. Although it has been possible to produce polyurethanes in the form of aqueous dispersion binders, by incorporating hydrophilic groups, these have not been able to compete with the dispersed binders obtained from emulsion copolymerisation because of their relatively high cost.

Crosslinking

Elasticity and improved adhesion of the film to the substrate is achieved by



Contents



Home

crosslinking. The crosslinking reaction must produce covalent bonds which are insensitive to hydrolysing agents (washing liquors, body sweat, industrial atmospheres). The reaction should be activated only during fixation and not while the binder and the printing pastes are in storage.

The simplest crosslinking reaction would be the condensation of carboxyl groups with hydroxyl groups of film-forming macromolecules. The disadvantages of this process are that it needs very high temperatures and an acid medium, and thus entails the risk of the textile yellowing, and that an ester bond is formed which is relatively sensitive to hydrolysis.

Crosslinking through *N*-methylolamide groups takes place under milder conditions, also in acid media (Scheme 5.1, where B is the principal part of the binder molecule). The compounds formed are relatively fast to hydrolysis as the consequence either of a reaction of methylol groups with each other, or of a reaction of methylol groups with hydroxyl groups which are also present in the binder copolymer. The reaction equilibrium requires that water is removed from the reaction system. Hot air above 120 °C is therefore suitable for this type of reaction. Steam can have adverse effects on crosslinking and consequently on the fastness of the print. High-temperature steam is of course able to remove water, but it is nevertheless itself water vapour and the reaction cannot go completely to the right. The effect of dry hot air is better.

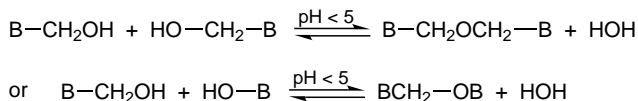

Scheme 5.1

This poly-*N*-methylol crosslinking of aqueous pigment print binders was first introduced in 1955. Today, it is common for monomers (such as methylolacrylamide, methylolmethacrylamide or the more stable methyl ethers of these compounds) to be polymerised with the main monomers (such as acrylic acid esters, acrylonitrile or butadiene) in such a way that the macromolecules contain about 2% *N*-methylol groups, evenly distributed along the chains. A considerably larger percentage of methylol groups would result in the chains being fixed too rigidly together after the crosslinking reaction: the extensibility, and with it the resistance of the binder film to rubbing and washing, would be impaired as a result of ‘overcrosslinking’, and the handle of the printed article would be stiffened.

Other crosslinking mechanisms have been based on epoxy and chloromethyl groups, which react with hydroxyl and amino groups under warm alkaline conditions,



or on polyethyleneimines, which react with carboxyl and hydroxyl groups. These, however, have not become important. Binders with such crosslinking groups are not sufficiently stable during storage; they react prematurely. Moreover, polyethyleneimines are toxic. All ingredients in pigment printing must be physiologically harmless at every processing stage, and since there is no final washing process this is especially vital for the consumer.

External crosslinking agents

Binders containing copolymers with *N*-methylol groups for 'internal' crosslinking may be combined with poly-*N*-methylol compounds as 'external' crosslinking agents. These are especially useful for prints on hydrophobic materials. The water-soluble methyl ethers of tetra- to hexa-methylolmelamines are preferred. They act mainly as adhesive agents between the textile and binder, but also contribute to the crosslinking at the surface of the binder film. Their reaction with the hydroxyl groups of aqueous thickeners and with nonionic dispersing agents based on polyglycol ethers also reduces the swelling of the film and improves the wet fastness of the prints. Because of their large content of very polar groups, the external crosslinking agents themselves form inextensible, rigid networks after the crosslinking reaction, and harden the handle of the printed goods a great deal more than does the binder film. For this reason only relatively small amounts, up to about 10% based on binder quantities, are used.

Since 1953 one of the oldest aqueous binder systems has used external crosslinking agents which, because of their epoxy and chloromethyl groups, react under alkaline conditions. The stability of the printing paste during storage is achieved in the products and pastes by including an excess of volatile organic acid. The crosslinking reaction begins when the acid is vaporised or neutralised with aqueous alkali [5,6].

5.2.3 Thickening systems

The colloidal polysaccharide thickening agents, such as starch, cellulose ether, alginates or locust bean gum, have been used successfully throughout the history of textile printing in printing pastes for various groups of dyes. They are not suitable for pigment printing, however, because their flow properties are unsuitable and because the films they form are brittle. The prints produced with such thickeners are dull and flat, with poor fastness and a harsh handle.

It is necessary for pigment printing pastes to have pseudoplastic (shear-thinning) flow (see section 7.7.3); they can then be transferred on to the textile material easily, but their penetration is limited. Pseudoplastic flow is usually found in heterogeneous and, physically speaking, coarsely dispersed systems. Flow occurs under shear, but when the shear is removed the pastes return to the consistency of a solid on the surface of the



textile. Unlike pastes with no yield value, they cannot penetrate deep down into the textile because of their rheology. Since they therefore remain on the fabric surface, they produce much better colour value, a sharp mark and brilliance of colour. In addition, because of the superficial coating of the fabric with printing paste, the textile yarns are not bonded to each other by the binders and crosslinking agents, and this results in a better handle to the printed goods. The hardening of the handle of the textiles after printing is mainly caused by the sticking together of the yarns and fibres, and this harshness can be broken down by using a suitable breaking machine. It is important for the fastness to wear and to washing that the same flow characteristics also hold the binder, crosslinking agent and pigments very close to one another.

Typical systems, and the ones most suitable for pigment printing, are the emulsion thickeners, of which the white spirit/water emulsions (o/w type) were of greatest practical interest. They consist of about 70% by mass of hydrocarbons in the disperse phase, 0.5–1% of nonionic emulsifiers with HLB in the region 12–15, and 29% of water in the continuous phase. The droplet size of the emulsified white spirit depends on the emulsifying agent and the efficiency of the high-speed mixer necessary to produce the emulsion. Efforts must be made to achieve a uniform droplet size (homogeneous emulsions), as this gives maximum stability and yield value. For physiological reasons the white spirit should have as little toxicity and aroma as possible, and a flash point of at least 30 °C, a boiling range of between 160 and 200 °C and a density of 0.76–0.80 g cm⁻³ are desirable.

Emulsion thickeners of the white spirit type are particularly suitable for pigment printing because all the components, except the emulsifying agents, will evaporate completely, leaving no residues. The thickener does not therefore cause any hardening of the handle of the textile and, because the evaporation enthalpy for white spirit is about 25% of that for water, drying of the printed textile is quicker; this improves the printing speed and consequently the production output. This is particularly important in drying chambers with a limited drying capacity.

On the other hand, mineral oil products are too valuable to be used just as print paste thickening agents and, for environmental reasons, the emission of organic substances into the atmosphere has met with opposition in many countries and has been prohibited by law in some. Recovering the white spirit from the exhaust gases of drying chambers, by means of cooling apparatus and batteries of charcoal filters, is too complicated and too expensive to provide a solution to this problem. The burning or catalytic combustion of evaporated white spirit, to comply with emission protection laws, also requires substantial capital expenditure. It is vitally important that the gases in the dryer should contain no more than 0.4% by volume of white spirit, to avoid explosions in the plant. White spirit emulsions for pigment printing are therefore being phased out all over the world; perhaps this may be regarded as a sign of our times.



In the 1960s, in anticipation, synthetic-polymer thickening agents were developed for pigment printing, with rheology similar to that of emulsion thickeners and extremely low solids content [7,8]. They are polyanionic compounds derived from monomers such as acrylic acid and maleic anhydride. A small degree of transverse crosslinking of the polymer molecules is built in, so that packets or bundles of chain molecules are held together. These products have very high swelling power, which is at a maximum at pH 9–10 when ionisation increases the degree of solvation in water. The original polymer with undissociated carboxylic acid groups will be in the coiled-chain form. Neutralisation leads to a straightening and separation of the polymer chains because the carboxylate ions are fully dissociated and strongly repel one another. This brings about a hundredfold expansion in size and the solvated particles then have dimensions similar to those of the white spirit droplets in emulsion thickeners. When the water-swollen particles are tightly packed they give a paste with pseudoplastic flow properties.

As coarse colloids they are subject to salting-out effects, and small additions of electrolyte reduce the viscosity, which is not the case with white spirit emulsions. Another disadvantage is that, on drying, this type of thickener leaves a residue; depending upon the requirements, 0.5–1% of solid substance remains on the textile. This residue, because of its extremely polar character, produces a hard, inflexible film which can (depending upon its chemical constitution and particularly in the case of carbonamide groups) react with crosslinking agents. This rigid film has an adverse effect on the handle of the printed goods, although it is considerably less than that of polysaccharide thickeners. The effect on the handle can be satisfactorily balanced by adding suitable softening agents, such as polydimethylsiloxane, mineral oils or synthetic wax. The neutralising agent, usually ammonia, in the synthetic thickener is removed under drying and fixing conditions; the free carboxyl groups in the polyanion then produce the acid medium which the binder and external crosslinking agents require for the crosslinking reaction. Printing pastes based on emulsion thickeners need about 0.5% potential acid, such as diammonium phosphate, in order to obtain the necessary acid medium during fixation.

Some manufacturers have combined softeners, synthetic thickeners neutralised with ammonia and dispersing agents to make application simpler and have marketed these products in paste form ('printing concentrate').

Emulsion and synthetic thickeners can be grouped under the heading 'disperse thickeners'. They are to a large extent interchangeable. If, for example, it is not possible to print economically with spirit-free pastes on the grounds of inadequate drying capacity, an emulsion thickener and a synthetic thickener can be used together to give pastes containing perhaps 25% white spirit.



The printer knows from experience that ‘short’ flow pastes (see section 7.7.3) are more sensitive to crushing effects (section 1.3.2) than are ‘long’ pastes. The less mobile the pastes are on the textile, the more easily are they picked up on the following printing rollers, in the case of multicoloured prints. This phenomenon makes itself unpleasantly noticeable, particularly in roller printing, with disperse thickeners having yield values and very steeply decreasing shear resistance; the original colour depth may be reduced by up to 70% after three or four times crushing.

In screen printing the decrease in colour depth as a result of crushing is not nearly so pronounced, but for this reason there is the risk that uneven prints will be obtained on smooth, hydrophobic textiles. In flat-bed screen printing there may, in addition, be screen frame marks. Combinations of disperse thickeners with colloidal thickeners (for example, cellulose ethers of average viscosity) reduce the crushing effect considerably. The pastes are, in the printer’s terms, softer or longer. The larger the proportion of colloidal thickener in the printing paste, the harder is the handle of the printed goods. Auxiliary substances with dilatant flow properties are more suitable and are effective as ‘flow moderators’ in comparatively low concentrations [9–12].

5.2.4 Pigment printing pastes

Although the products needed for the production of pigment printing pastes are marketed under the trade names of various manufacturers, very few differences in their basic composition are worthy of mention. The results obtained from the various systems may differ, however, especially from the viewpoint of problem-free printing properties, fastness properties, evenness, brilliance and handle of the goods.

The ratio of the amount of pigment paste to binder necessary to produce good fastness properties is influenced by the fact that even the smallest amount of pigment (perhaps 1 g pigment paste per kg paste) requires a layer of binding film at least 5 µm thick. Including a safety factor, this means a minimum of about 7% binder (of about 40% solid content) in the paste. Additional pigment needs about 1.5–2 times its own mass of binding substance. The relation shown in Recipe 5.1 results. For prints on hydrophobic materials (including polyester/cotton blends), another 0.5–1% of external crosslinking agent is added to the paste, depending on the colour depth and the desired wash fastness.

Recipe 5.1

Pigment paste (30–40% pigment content)	x g
requires	
Binder (approx. 40% solid content)	80 g + 3x/2 g



The reduction thickener contains 8% binder, and other components as listed in Table 5.1. Often several components (emulsifier, printing concentrate, crosslinking agent, softener and flow moderator) are combined in one product by the product manufacturers, which means that the recipe is simpler but also that there is not the same amount of flexibility with respect to optimum printing recipes.

5.2.5 Possibilities and limitations of pigment printing

There are of course limitations to balance against the substantial advantages of pigment printing. The printer should be fully aware of these, since the use of pigments in applications where dyes are required can bring about a negative attitude to pigments, even in suitable applications [9].

Advantages

1. Pigment printing is the most economical printing process and allows maximum output of goods because of the elimination of washing-off, quick sampling and high printing speeds.
2. Properly produced pigment prints, using selected products, have an unsurpassed fastness to light and good general fastness properties.
3. Pigment printing can be applied to all substrates which are of interest to the printer, including glass fibres, PVC and imitation leather, subject to some limitations in colour depth. It is extremely well suited for colour resist effects, for example, under azoic and reactive dyes.
4. Pigment printing presents the fewest problems for the printer of all the coloration processes, with regard to labour costs, equipment, and reliability of production. Mistakes in printing can be recognised quickly.
5. From the ecological point of view, pigment printing, using pastes free from white spirit, is more acceptable than any other system, excepting only transfer printing methods.

Disadvantages

1. The fastness levels of medium- or dark-coloured prints on materials made from polyester and acrylic fibres, as well as on wool, are at best only suitable for articles that will not be subjected to a great deal of wear. Dark-coloured prints on woven and knitted goods made of synthetic fibre blends are especially susceptible to abrasive wear, as well as to reduction in colour strength by frequent use or washing. This applies particularly to men's polyester/cotton shirts.



2. The handle of the printed goods is often unduly hard because of the large amounts of external crosslinking agents, and this necessitates aftertreatment of the prints on breaking machines to produce some improvement.

Table 5.1 Reduction thickener

<i>Emulsion</i>		
Start with	x g	water
Stir in	20–30 g	diammonium phosphate 1:2 in water
	40 g	thickening agent 3–4%
	0–5 g	softener ¹
	10–25 g	urea ²
	10–25 g	emulsifier ³
Stir in and mix well	80 g	acrylic- and/or butadiene-based binder ⁴
	0–10 g	crosslinking agent ⁵
	650–700 g	white spirit ⁶
	1000 g	
<i>All-aqueous</i>		
Start with	x g	water ⁷
	0–5 g	flow moderator ⁸
	5–20 g	softener ¹
	2–3 g	defoamer ⁹
	2–5 g	emulsifier ³
Stir in and mix well	25–30 g	synthetic thickeners ¹⁰
	80 g	acrylic- and/or butadiene-based binder ⁴
	0–10 g	crosslinking agent ⁵
	1000 g	

Notes

1. Softeners and lubricating agents are hydrophobic and must be carefully dispersed.
2. Used to prevent the print paste from drying prematurely, particularly in the case of emulsion thickeners.
3. Nonionic product, based on ethylene oxide derivatives; HLB values in the region of 11–15.
4. Because of the danger of yellowing with butadiene binders, acrylate binders are recommended for white pigment prints and for furnishing prints. Binders that have limited mechanical stability should be added only after emulsification of the white spirit.
5. Methylated methylolmelamines, which are marketed in the form of aqueous solutions.
6. When storing and emulsifying white spirit the local safety regulations must be taken into consideration. Efficient mixers, with a variable speed of between 1500 and 3000 rev min⁻¹, are necessary.
7. For the all-aqueous thickener, water with minimum electrolyte content produces a higher viscosity than hard water which contains an abundance of electrolytes. The water should also be neutral.
8. Dilatant synthetic product.
9. A solid substance should not be used. Specially prepared products are necessary. In emulsion pastes antifoaming substances are not normally required. Care should be taken that the defoamer chosen does not lose its effect during storage of the pastes and printing.
10. Quantity of thickener, neutralised with ammonia. Thickeners produced by emulsion copolymerisation are considerably weaker than precipitation polymerisation products. The fastness properties obtained are also somewhat worse.

3. Pigments are sensitive to crushing during roller printing, particularly where bulky materials and deep engravings are concerned. Pigment printing needs shallow engravings, and bulky textiles should be printed on screen-printing machines.
4. When pigments are overprinted, the second paste has little effect: the paste first printed on the fabric determines the colour. 'Fall-ons' must therefore be limited to outlines.
5. The original surface of the textile material is covered by the binder film. This is occasionally aesthetically effective, but usually undesirable.
6. No pigment print is completely fast to dry cleaning. Depending upon the pigment and binder (which must be characterised as 'fast to solvents'), the prints can show rub marks and/or a loss in colour depth.

This summary makes it clear that the best fields for the application of pigment printing are:

- decorative prints on cotton and regenerated cellulose materials (pigment printing has played a dominant role here for many years)
- furnishing prints with selected pigments and binders fast to weathering (pigment-printed areas become hydrophobic)
- women's and children's clothes, nightwear of woven and knitted material (cotton, spun viscose, nylon and blends thereof)
- cotton towelling goods (leisurewear, curtains, bathrobes)
- fabrics of nylon, cotton, polyester/cotton and spun viscose for aprons and bedlinen, in pastel and medium colours only
- women's outdoor wear made of cotton, spun viscose and blends with polyester up to medium colour depths.

For blotch prints on wool, polyester and acrylic fibres, pigment printing is less satisfactory where the blotch prints are darker and the mechanical demands during wear and washing are greater. There are limitations to pigment printing which are connected with local demands, which vary from country to country, and it cannot therefore be considered as generally accepted. Its reputation appears all too often to be threatened less by its use for colouring unsuitable substrates than by the poor fastness to wear and washing which results from the use of insufficient binder or inadequate fixation conditions. In these cases the only advantage of pigment printing, namely that irrespective of its fastness it produces attractive printing effects, becomes an aggravating disadvantage. Only during use or after the first few washes does one discover whether or not the fastness properties are good, or catastrophically bad. Strict control of fastness properties relative to trade demand is therefore absolutely essential.



5.3 CELLULOSIC FIBRES

Cotton, linen, viscose and polynosic fibres all consist of the same natural polymer, but differ in the chain length and orientation of their molecules and in their morphology. Natural and regenerated cellulosic fibres differ from one another not only in their degree of polymerisation, strength and elasticity but also in their impurities, the packing density of the molecules and their regain, their degree of crystallinity, and, above all, their capacity for dye sorption. The fastness properties of a dye differ on different substrates.

Pretreatment of fibres depends on the nature of the fibre concerned. Some foreign substances do not absorb the dye (cotton wax is an example) or are dyed a different colour from the fibre (pectin) or impair the clarity of the colour and the stability of the material (lignin). In fabrics which have poor wetting properties or tend to retain sizing agents, the absorption of the dye is considerably impaired. In the descriptions that follow it has been assumed that the goods to be processed have been pretreated, and are ready for printing.

5.3.1 Direct dyes

Direct dyes are characterised by their affinity for cellulose (arising from their chemical structure) and their solubility in water (the result of the presence of sulpho groups). This means it is possible to dye them easily and with some degree of fastness, even if limited. In printing practice, the direct dye in a thickened solution is printed on to the fabric and then dried.

During subsequent steaming in saturated steam the thickened paste and the fibres swell, and the dye dissolves again and diffuses from the film of paste into the fibres. Here the dye is held fast on the fibril surfaces by van der Waals forces and hydrogen bonds. After an adequate steaming time an equilibrium is established between dye in the fibre and dye in the paste. During the final washing of the print, however, the unfixed dye together with the thickening paste are rinsed off and can stain the undyed parts of the cellulose. At the same time the equilibrium, which has been established at this stage, can be disturbed by the dye migrating from the fibre into the washing liquor. For both these reasons, textile printing using direct dyes gives good results only if a special fixing agent is employed.

A quaternary ammonium (cation-active) compound may be applied after printing and steaming to interact with the dye anions. The larger, less soluble, complexes which are formed in the fibre as a result show considerably lower mobility, and the print is noticeably 'faster'. In many cases, however, the usually very good fastness to light deteriorates noticeably after such treatment. Alternatively, dyes suitable for aftertreatment with copper may be used. These are azo direct dyes which contain one



or two hydroxyl groups and one carboxyl group in positions *ortho* to the azo groups. The result is an increase in the size of the molecule around the central copper(II) ion, and a consequent noticeable improvement in light fastness properties. It is only the need for the relatively complex and lengthy process of aftertreatment with copper in a bath of acetic acid (10–30 min at 60–70 °C) that has prevented this group, which lies somewhere between direct and mordant dyes, from becoming significant in textile printing.

5.3.2 Acid and basic dyes

Acid dyes differ from direct dyes only in that their molecules are smaller, better brilliance can be obtained and they are able to dye protein fibres from an acid solution. Acid dyes show little affinity for cellulose and hence, in the light of what has been said in the previous section, their wet fastness properties are poor. The printing method and the need to improve fastness are common to both acid and direct dyes.

Both classes are of little importance in textile printing; they are used only for the production of cheap goods. Such goods can also be printed with basic (cationic) dyes, which dye by a completely different mechanism and can be dyed on cellulose only with the help of a mordant.

Tannin, a glycoside of gallic acid, and tartar emetic (antimony potassium tartrate) together form a mordant on the cellulose in the form of an insoluble compound, which has not been defined in any detail chemically but which possesses acid groups. The dye cation can form a water-fast complex salt with these acid groups during a lengthy steaming process. Dyeings and prints produced in this way have a high degree of brilliance, but poor fastness to light. Synthetic products, such as those marketed under the names Katanol ON and Thiotan MS, may be used instead of tannin. These products are in some cases applied together with the dyes from the printing pastes, but then a longer steaming process for fixing is required. This process is no longer very important today.

5.3.3 Mordant dyes

Many of the natural dyes are mordant dyes; Alizarine red (CI Mordant Red 8), Persian berry yellow (CI Natural Yellow 13) and Logwood black (CI Natural Black 3), for example, were of enormous importance in early textile printing. Synthetic mordant dyes, sometimes described as chrome colours, have also been used in large quantities for printing cotton.

The dyes themselves have little affinity for the fibre, but can be printed with additions of hydrolysable metal salts (mordants) to give dye–metal complexes during



steaming. With some dyes the use of salts of chromium, aluminium or iron or, less frequently, nickel, cobalt or zinc gives different colours. Good fastness properties and low dye costs are characteristic.

These dyes are no longer of great importance, however, because of the problems they present under modern conditions. Their disadvantages include limited print paste stability (due to premature complexing), steaming times of up to 1 h and deterioration in fabric handle as a result of interaction between thickener and metal salt.

5.3.4 Vat and sulphur dyes

Vat and sulphur dyes are dealt with together here because their method of application is similar. They differ entirely in their chemistry, however, and in their importance in textile printing. Whereas in this field vat dyes are still widely used, the use of sulphur dyes is restricted mainly to the production of black.

The dyeing mechanism in both cases depends upon the insoluble dye being transformed into a water-soluble alkaline leuco compound under the influence of alkalis and reducing agents. The alkaline leuco compounds diffuse from the thickener into the swollen fibres, during the steaming process. Oxidation then precipitates the dye in a finely dispersed insoluble form inside the fibre, to give a print with typically good fastness properties.

The formulae for indigo (CI Vat Blue 1) and indanthrone (CI Vat Blue 4) (5.2, 5.3) illustrate two typical vat dye structures and their reversible reduction–oxidation behaviour. The presence of at least two conjugated carbonyl groups is common to all vat dyes [13]. Sulphur dyes are, in chemical terms, complex molecules produced by the reaction of alkali sulphides with simple organic compounds, in which thiazine and thiazole rings provide the chromophore groups.

It is not normally possible to print vat dyes in the leuco form, because exposure to air during and after printing results in premature oxidation. For the same reason, the reducing agent itself must either be stable in air or be introduced at a late stage in the process. Both approaches are important, the former in the 'all-in' method and the latter in the two-phase or two-stage process.

All-in method: In 1905 it was discovered that sodium formaldehyde sulphonylate, $\text{CH}_2\text{OHSO}_2\text{Na}$, had the required stability at low temperatures and reducing action in steam to be used in vat print pastes. A typical paste, as formulated in Chapter 8, can be stored for long periods, printed and dried with only a small loss of reducing power. When the print is steamed in air-free steam, reduction of most vat dyes is efficiently brought about. The control of conditions for optimum fixation is discussed in Chapter 8.



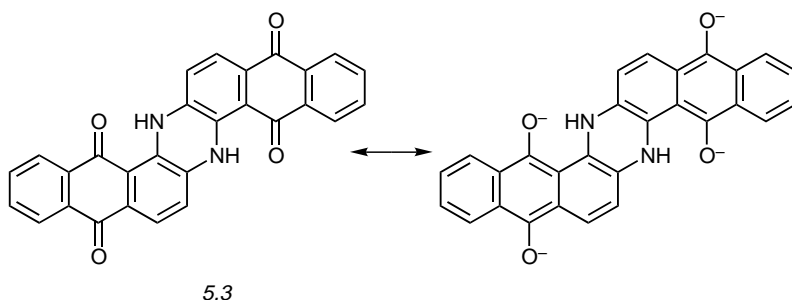
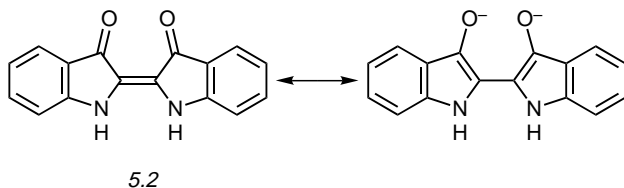

Potassium carbonate has been preferred to the cheaper sodium carbonate because of its higher solubility, and the danger of a hydrated sodium carbonate crystallising out from the paste, which can cause 'doctor streaks'. The higher solubility of potassium salts of vat leuco compounds is also advantageous.

Vat dyes marketed for printing should be of small particle size and of crystal form selected to give maximum rate of reduction. Colourless reduction accelerators, such as aminoanthraquinonesulphonic acids, are often incorporated. It has been observed that the reduction of a vat dye is often catalysed by the presence of another vat dye, and the choice of thickener can also affect the reduction rate. The use of British gum thickenings has been shown to accelerate decomposition of the sulphoxylate.

Two-stage method: Indigo can be printed together with caustic soda on to cotton fabric previously padded with 25% glucose solution. Reduction occurs in steam. In this traditional method premature oxidation was avoided by applying the reducing agent and dye separately, in two stages. A two-stage method that is now employed to print the complete range of vat dyes starts with dye and thickener only. The alkali and reducing agent are subsequently applied by padding. Steaming follows immediately, so that even sodium dithionite (hydrosulphite) can be used because exposure to air is limited to a few seconds. Substantially more water is present than in the steaming of all-in prints, and this leads to higher and more reproducible fixation levels. Delays between printing and steaming also cease to be disadvantageous.



In order to prevent smudging or bleeding of the printed colour, it is necessary either to use a thickener that coagulates in the presence of alkali, or to add borates to the pad liquor. The extent of coagulation should be controlled, however, to make subsequent removal at the washing-off stage easier. Mixtures of coagulation thickeners are therefore often preferred.

The conditions of padding must also be considered. The time of contact between printed fabric and the liquor should be kept short, by nip padding or use of a two-roll horizontal pad or even of an overall engraved printing roll.

Steaming times can be as short as 20 s ('flash ageing') or longer if less severe reduction conditions are preferred. In either case the printed face is not allowed to contact carrying rollers until fixation is complete.

Solubilised vat dyes

Vat dyes provide a wide range of colours of good all-round fastness properties, but great care, or specialised equipment, is required for their successful use. The solubilised vat dyes offer a simpler method of application, at somewhat higher dye cost. The leuco forms of many vat dyes can easily be transformed into sulphuric acid esters, which can be isolated as stable powders. They are water-soluble, have affinity for cellulose and, after printing, can be oxidised under acid conditions to the insoluble parent vat dye. Exposure to light can cause premature oxidation, which must normally be avoided; this can be exploited, however, for the production of photographic effects on fabric.

Very deep colours are impossible to obtain, or of prohibitive cost. These dyes have consequently rarely been used alone, but they have found application to supplement the azoic colours. Two methods of fixation have commonly been used: the nitrite and the chlorate processes.

In the former, sodium nitrite is incorporated either in the print paste or in the naphthol preparation. After printing and drying, followed by a short steaming for optimum yield, development is obtained by a short immersion in dilute sulphuric acid.

When sodium chlorate is used as the oxidising agent, the alkalinity of the colour print paste is maintained with ammonia, and an acid generator, usually ammonium sulphocyanide, is activated by steaming. Ammonium vanadate is also needed, in small quantity, as an oxidation catalyst.

5.3.5 Reactive dyes

The full gamut of colours in the reactive class of dyes, which is one of its significant advantages, is obtained by employing a wide range of chromophores. The introduction of reactive dyes for cellulosic fibres has given the printer the possibility of using only



one type of dye and simple application conditions, in place of the complex permutations necessary at one time.

The formation of a covalent bond between dye and fibre makes it possible to use dyes which, unlike the vat and direct dyes, are of small molecular size and good solubility. These dyes can be brighter, faster-diffusing and, in the hydrolysed form, easily removed in the washing-off process [14,15].

When selecting reactive dyes for printing, the factors of importance for dyeing must be considered but, in addition, attention must be paid to print paste stability and staining of the ground during washing-off [16,17].

As with vat dyes, it is possible to use either an 'all-in' print paste or a two-stage pad-steam approach. The first method has simplicity, but the need for print paste stability limits the selection of dyes to those with a low rate of hydrolysis.

Fabric pretreatment

For optimum results, pretreatment of the cellulosic fibre is especially important when reactive dyes are used. Woven fabrics must be thoroughly desized as reaction with size and azo dye reduction, under hot alkaline conditions in presence of reducing end-groups, both lead to lower colour yield. Mercerisation of cotton, or semi-mercerisation, is recommended because few reactive dyes give full colour value on unmercerised cotton. If this is not possible, however, dyes that diffuse rapidly and show minimum differences in yield may be selected.

With regenerated cellulose also, suitable pretreatment leads to improved prints [18]. Swelling in caustic soda solution of 4–6 °Bé at room temperature, under tensionless conditions, improves the colour yield of the print. The fabric should be well rinsed, but not neutralised, to achieve maximum effect. An alternative would be to pre-pad with 100 g l⁻¹ urea and 10 g l⁻¹ soda ash.

Printing by the all-in method

A typical print paste is prepared by sprinkling the required amount of reactive dye into a stock paste (Recipe 5.2). The solubility of most reactive dyes is sufficient for this sprinkling method, followed by high-speed stirring, to give perfectly smooth prints. The dye can alternatively be predissolved, using the urea to increase the solubility, in a small volume of hot water. Sodium bicarbonate should only be added after the mixture of dye solution and thickener has cooled to room temperature.

Thickeners: Alginates are the only natural thickeners suitable for use in printing with reactive dyes. All other carbohydrates react with the dye and this results in low colour



yields or unsatisfactory fabric handle due to insolubilisation of the thickener. Sodium alginate also contains hydroxyl groups but it reacts very little, presumably because the ionised carboxyl groups on every ring of the polymer chain repel the dye anions.

Recipe 5.2

Alginate thickener (3–12%)	400–500 g
Urea	100–200 g
Sodium bicarbonate	20 g
Sodium <i>m</i> -nitrobenzenesulphonate	10 g
Water	470–270 g
	1000 g

Because of the relatively high cost and limited supply of alginates, attention has recently been paid to finding alternatives. Synthetic thickeners with anionic charges show great potential. Poly(acrylic acid) does not react at all with typical reactive dyes and colour yields are higher than with alginates. Washing-off is difficult, however, and the handle may be impaired.

Emulsions of both *o/w* and *w/o* types are also suitable and ‘half-emulsions’ have been widely used. A stock paste of the half-emulsion type (*o/w*) can be prepared by Recipe 5.3.

Alkali: Alkali is essential to produce ionisation of accessible cellulose hydroxyl groups, which can then react with the reactive dye. Sodium bicarbonate has been the preferred alkali because it is cheap and gives sufficient print paste stability with all but the most reactive dyes. During steaming or baking it loses carbon dioxide, and increased ionisation of cellulose follows. Where the stability of the dye is high enough,

Recipe 5.3

Emulsifier	10–20 g
Water	280–90 g
Urea	80–150 g
Sodium bicarbonate	20 g
Sodium <i>m</i> -nitrobenzenesulphonate	10 g
Alginate thickener (3–12%)	100–200 g
White spirit, added with high-speed stirring	500 g
	1000 g



sodium carbonate and even caustic soda may be preferred because the more stable dyes will give higher colour yields under more alkaline conditions.

For dyes of high reactivity the concentration of bicarbonate may be reduced or sodium trichloroacetate used. The latter decomposes during steaming to form sodium carbonate, and allows the use of neutral print pastes or even pastes slightly acidified with acetic acid.

The choice of alkali must therefore be made on the basis of the reactivity of the dyes to be used and the stability of print paste required. Acceptable stability, for 28 days, for example, is normally attainable.

Fixation: In textile printing it is most important that the fixation and hydrolysis proceed to completion, so that no dye in reactive form remains to stain the white ground. The choice of dyes to be used must therefore be determined by the fixation equipment available [19]. Dyes of high reactivity allow the use of rapid fixation processes, but if some of the dyes have lower reactivity it is safer to use normal steaming times and temperatures.

The second factor, which then becomes relevant, is the stability of the dye–fibre bond under hot alkaline conditions. Too long a fixation time will lead to a fall in colour yield. For most reactive dyes the stability of the dye–fibre bond is related to the reactivity of the dye, and it is possible to obtain rapid fixation under mild conditions only at the expense of stability of the print paste and of the dye–fibre bond. Higher reactivity can, however, be obtained by using reactive fluoro compounds, rather than the chloro analogues, without affecting the dye–fibre bond stability. Reactive dyes based on fluorochloropyrimidine exemplify this approach.

The actual level of fixation is important, not only for economic reasons as in dyeing, but also because unfixed hydrolysed dye must be removed very thoroughly. A routine washing-off procedure may be inadequate if the percentage of unfixed dye is higher than normal. One successful approach to obtaining significantly higher fixation levels has been to build two reactive centres into each dye molecule. This increases the probability of reaction with the fibre and leads to fixation levels of about 90%, rather than the usual 70%, and consequently reduces by two-thirds the amount of hydrolysed dye to be removed [20].

The fixation of most reactive dyes is effected by saturated steam at 100–103 °C within 10 min. The most highly reactive dyes may require only 1 min.

Faster fixation is obtained in superheated (high-temperature) steam at temperatures of 130–160 °C, 30 to 60 s only being required. Such short reaction times allow the use of smaller steamers ('flash agers'). Some of the savings in capital expenditure on plant may, however, be offset by the necessity to use higher concentrations of urea in the print paste. When cold printed fabric is entered into superheated steam, almost the



same amount of water condenses on to the fibres as with saturated steam, but loss of this water follows. Urea holds some of the water very strongly, and the eutectic mixture of urea and water provides the solvent required for the dye–fibre reaction to occur. In the absence of urea colour yields are low, unless fixation can take place during drying. For many dyes, colour yield increases up to a maximum when 150–200 g kg⁻¹ of urea are used. An alternative is to use controlled damping at the steamer entrance [21].

Because reactive dyes are typically of small molecular size and low affinity, fixation can be achieved even in hot, dry air. Urea at concentrations of 150–200 g kg⁻¹ is essential, and selection of dyes is more critical than for steaming processes, especially for regenerated cellulose. Dyes of high diffusion rate and reactivity give the best yields [19,22]. The diffusion of dye and alkali into the fibre that occurs before and during drying must materially affect the fixation that is achieved.

When hot-air bakers are used, as they are for crease-resist finishing, times of 1–3 min are required at temperatures of 180–160 °C. The time required is of course dependent on the rate of fabric heating and can vary substantially from one machine to another.

When contact heating is employed, using heated cylinders or a transfer printing drum, the fabric attains the required temperature very rapidly and a time of 1 min at 150 °C is often adequate. Some stiffening of regenerated cellulose fabrics must be expected, and discoloration of the cellulose can limit the brightness of pale colours.

Printing by two-stage methods

Reactive dyes can be printed without alkali, an alkaline solution being subsequently applied to bring about fixation [23,24]. Because the volume of water in the fabric at the fixation stage will be at least 50%, rather than the 20% or less in all-in processes, there is no necessity for high concentrations of urea. Up to 50 g kg⁻¹ may, however, be used to improve solution of dye in the print paste.

Sodium alginate shows the required thickener properties. The composition of a typical stock paste is shown in Recipe 5.4.

Recipe 5.4

Urea	0–50 g
Water	440–590 g
Sodium <i>m</i> -nitrobenzenesulphonate	10 g
Alginate thickener (3–12%)	400–500 g
	1000 g



Fixation: Application of an appropriate solution of alkali will initiate dye fixation, which is usually accelerated by raising the temperature but can be allowed to proceed more slowly, at room temperature.

Because reactive dyes have high solubility and high rates of diffusion, it is important to use alkaline solutions with a high electrolyte concentration to prevent loss of dye from the printed areas and consequent bleeding and staining. Two types of solution have been found to be suitable for padding or wet fixation processes:

- high concentrations (47 °Bé) of sodium silicate ($\text{Na}_2\text{O}:\text{SiO}_2 = 1:2.1$) and
- mixed alkali solutions, with a possible addition of salt (Recipe 5.5).

Recipe 5.5

Soda ash	185 g
Potash	185 g
Water	600 g
Caustic soda (38 °Bé)	30 g
	1000 g

The alkaline solution can be applied on a vertical two-bowl padder at high speed or, if lower speeds are used, on a horizontal two-bowl or nip pad. The steam temperature is preferably at least 130 °C, for a steaming time of 30–50 s. Washing equipment is usually coupled with the steamer for immediate removal of unfixed dye.

With dyes of high reactivity it is not necessary to steam, and an ‘alkali shock’ process can be employed for prints on cotton fabric: 10–20 s passage in open width through the alkaline liquor (as above) at 100–103 °C is followed by immediate washing. The high electrolyte concentration allows the use of temperatures up to 105 °C, without pressurisation, because of the elevation of the boiling point. The process is not suitable for viscose fabrics.

An alternative approach uses a longer fixation time at, or near, room temperature. The fabric is batched after pad application of the development liquor, at 70–80% pick-up. Fixation takes place while the batch is left standing for about 6–12 h. Wrapping the batch in plastic film protects the fabric from acid in the atmosphere and prevents drying at the edges.

Sodium silicate liquor can be padded at 40 °C to reduce its viscosity and assist penetration.



Washing-off of reactive prints

In the early years of printing with reactive dyes, difficulties were experienced at the washing-off stage. Some unsuitable dyes, of high substantivity, were used, and the fixation conditions were not always adequate. By selecting dyes of lower substantivity, and using methods appropriate to their reactivity, washing is significantly simplified but remains important.

The first step must always be a thorough rinsing with cold water. If the print is dry, the thickener film must be allowed time to swell. Alkali, electrolyte and most of the thickener should be removed in this first stage. Surface dye, which should all be hydrolysed, will also be rinsed off.

High-temperature washing, close to the boiling point, is then used to remove hydrolysed dye from inside the fibres. For any dye there will be a minimum combination of time and temperature to complete the removal by diffusion from the fibre. Longer times will be required if inadequate flow of washing liquor slows down the removal of dye from the fibres. Surface-active agents do not, in general, improve the washing effect. If hard water is used thickener removal will be more difficult, and addition of sequestering agents will be advantageous.

A cold rinse completes the washing. It is not wise, and should not be necessary, to use cationic fixing agents. Adsorption of cations on to unprinted areas increases the affinity for traces of hydrolysed dye, and makes any staining more difficult to remove.

Effect of chemical finishing

Most cellulosic fabrics printed with reactive dyes and used for shirts, dresses and similar apparel are given chemical finishes to improve their easy-care properties. The crosslink finishes are achieved with catalysts which are usually left in the fabric, even though they develop acidity. If the fabric, and garments made from such fabric, are stored for any length of time, especially in damp and warm conditions, some hydrolysis of the reactive dye–fibre bond will occur. Mild household washing of such garments is not likely to remove this hydrolysed dye completely and staining may occur.

Clearly, an alkaline wash to remove catalyst residues, as well as free formaldehyde (methanal), is highly desirable. An aftertreatment of finished fabric with cationic agents is often used as an alternative. It is also possible to choose reactive dyes that form covalent bonds with high resistance to acid and alkaline hydrolysis.

Some change in colour and in fastness to light can also occur as a result of finishing. The extent of the changes depends on the dyes, catalysts and crosslinking agents used. Ammonium salts and nitrates used as catalysts have particularly adverse effects.



5.3.6 Insoluble azo colorants (azoics)

The main characteristic of the azoic colorants is that they are formed in the fibre as a result of a chemical reaction. This reaction depends in the first place on the capacity of an aromatic amine to react with nitrous acid to form a diazo compound, and then on the reaction (coupling) of this diazo compound with a suitable organic grouping to form an azo linkage. Both reactions are among the oldest known reactions in organic chemistry, and have been well reviewed [25].

In order to produce insoluble azo colorants in the fibre, diazo compounds of selected amines (the so-called ‘fast colour bases’) and selected coupling components (generally known as ‘naphthols’) are used in textile printing. Two possibilities are available:

- the coupling component and diazo component can be applied separately (Method A), or
- the coupling component and a stabilised diazo component can be applied together (Method B).

Initially, Method A was used for applying insoluble azo colours. In 1880 the British firm Read, Holliday and Son found that a red dye was produced on some cotton fibres by impregnating with an aqueous solution of the sodium salt of 2-hydroxynaphthalene (β -naphthol), and then developing it with an aqueous solution of diazotised aromatic amine, such as 4-nitroaniline. The product of 4-nitroaniline coupling with 2-hydroxynaphthalene became known by the name of Para Red (CI Pigment Red 1); over many decades in the past millions of metres of cotton fabric were dyed and printed with Para Red. Since diazotisation must take place at low temperatures in order to avoid premature breakdown of the diazo compound, ice was added to the reaction solution to cool it down, and hence the name ‘ice colours’ became linked with dyes of this nature.

The first coupling component, and the most widely used, was the above-mentioned 2-hydroxynaphthalene. This was later replaced by the arylamide of 2-hydroxy-3-naphthoic acid, discovered by Laska and Zitscher in 1911. This new coupling component, generally known today as Naphtol (or Naphthol) AS, made it possible to achieve dyeings of a previously unknown brilliance and fastness [26]. The Naphtol AS series has subsequently been greatly expanded and it is now possible to reproduce many colours with almost every desired fastness property. Besides the arylamides of 2-hydroxy-3-naphthoic acid (Naphtol AS, AS-D, AS-OL, AS-E and many others), arylamides of the *o*-hydroxycarboxylic acids of anthracene (Naphtol AS-GR), carbazoles (Naphtol AS-LB) and benzocarbazoles (Naphtol AS-SR and SG), as well as diphenyloxides (Naphtol AS-BT) were used as coupling components. Using these compounds it is possible to produce greens, browns and blacks with, in some cases,



remarkable fastness. Another important group of coupling components is the acylacetylammides, derivatives of the acetoacetic acid derivative (Naphtol AS-G). The individual members of this group can be combined with red bases to form yellows with the necessary fastness properties, and they have therefore become known as Yellow Naphtols. In 1958 another coupling component, based on the phthalocyanine molecule, found its place among the Naphtol AS products (Naphtol AS-FGGR). This Naphtol produces brilliant yellowish greens, which show excellent fastness [27].

Most of the diazo components are derivatives of aniline, 2-methylaniline or 2-methoxyaniline. Other substituents in the benzene nucleus are chloro, nitro, cyano, trifluoromethyl, carbonamide, sulphone, sulphonamide, arylamine and acylamine groups. The rather complicated process of diazotising bases and the poor stability of diazo compounds have made the textile finishing industry look for diazo components with adequate coupling capacity which are nevertheless stable. These compounds should be stable during storage, should not be dangerous, should be easily soluble in water and should couple quickly with the coupling component. The first preparations of this sort were powder mixtures, which contained diazo components in the form of water-soluble salts, but not in a concentrated form for safety and storage reasons. They were produced by concentrating the diazonium salt solutions in a vacuum at low temperatures, and blending the product with simple salts.

Further development led to precipitation of the diazonium salts from aqueous solution as complex salts with halides such as zinc chloride, complex fluorides of boron or salts of aromatic sulphonic acids. These products are still known as 'Fast Colour Salts' in the trade. The salts have the special merit that they are very soluble, stable and easily weighed out.

There is no general rule as regards the properties and fastness of the possible insoluble azo colorants. If the coupling component is of the 2-hydroxy-3-naphthoic acid type, then the colour produced depends greatly on the type of diazo compound (hence the trade name for a Fast Colour Salt). The useful combinations were determined empirically. Conclusions about the relationship between properties and composition could only be drawn afterwards on the basis of a large amount of research.

Base printing: A summary of how to apply coupling and diazo components separately (Method A) is given in Recipe 5.6. Nearly all naphthols can be used for impregnation, but those of low substantivity, Naphtols AS, AS-D, AS-OL and AS-G, have become the most important in practice. Dyes of different classes, including soluble vats, reactive dyes, pigments, Phthalogen dyes and others, may be added along with Fast Colour Salts as complementary dyes in base printing. This method is very popular for Africa prints (section 6.5.1).



Recipe 5.6

1. Impregnate the fabric with an alkaline solution of the naphthol, followed by drying; this first stage is often called 'preparation'
2. Develop (couple) by printing with the thickened solution of diazo component
3. Rinse and soap to remove unfixed components.

Recipe 5.7

Naphthol AS (sprinkled and dissolved)	20 g
Soft water (90 °C)	800 ml
Caustic soda (38 °Bé)	20 ml
Dispersing agent	6 ml
	1000 ml

Recipe 5.7 illustrates preparation of a sodium naphtholate solution. The goods are impregnated on a pad mangle, at a temperature of 90–95 °C. It is advisable to dry them on a hot flue or a cylinder dryer. The naphthol-prepared goods, when stored, must be protected from light, moisture and acid fumes.

Recipe 5.8 summarises the preparation of a printing paste. Cellulose ethers, locust bean or guar products are generally used today as thickening agents.

The following sequence is recommended for washing, in open width or rope form:

1st beck	Water at 80–90 °C: 10–20 ml l ⁻¹ sodium bisulphite 38 °Bé
2nd beck	Water at 80–90 °C; 3–5 g l ⁻¹ soda ash
3rd–6th beck	Boiling water with 0.5 g l ⁻¹ washing agent and 1 g l ⁻¹ polyphosphate
7th beck	Warm water
8th beck	Cold water

If, instead of using Fast Colour Salts, the bases are diazotised by the printer, then the manufacturer's recommendations should be followed.

Naphtholate printing: By printing two or more naphtholates which produce different colours with one Fast Colour Salt, a multicolour effect can be obtained.

The process consists of printing the thickened naphtholate solution, drying, and passing the printed fabric in open width through a developing bath containing a diazo



Recipe 5.8

Fast Colour Salt	30–60 g
Acetic acid (50%)	1–20 g
Sodium acetate	10 g
Cold water	150–200 g
Dispersing agent	1 g
Thickener	400 g
	1000 g

salt. After squeezing, the fabric is allowed an air passage, and then rinsed through a bath of hot sodium bisulphite solution, rinsed and soaped hot.

By reducing the concentration of naphtholate printing colours, both light and dark colours may be printed next to each other. It is possible to expand the existing range of colours by mixing selected naphthols. Naphtholate printing has, however, never acquired the importance or popularity of base printing [28].

Rapid Fast and Rapidogen colours

Method B, the application of coupling component and stabilised diazo component in a single printing paste, has obvious advantages.

The first products of this kind were made in 1914 and they were introduced into the trade under the name of Rapid Fast colours. The practical range of colours is limited, however, and the necessary activation of coupling by acid steaming is not a popular process.

Rapidogen colours are essentially equimolar mixtures of a water-soluble diazoamino compound (or triazene) and a coupling component.

Compared with the antidiazoates used in Rapid Fast colours, diazo compounds stabilised as triazenes have the advantage that they produce more brilliant prints. Furthermore, this triazene principle can be applied to nearly all bases, which leads to a considerably larger range of dyes.

When Rapidogen colours were first introduced they had to be fixed in an acid medium, either acid steam or a developing bath of hot dilute acid. These fixing processes have hardly any significance today: fixation is almost exclusively by neutral steaming, which makes it easier to combine them with other dye classes. Stabilising amines such as *o*-carboxyphenylglycine provide the required reactivity. This kind of dye is marketed under the trade names Neutrogene (FMC), Rapidogen N (BAY) and



Sinagene (Rohner). The range includes nearly all colours: yellow, golden yellow, red, bordeaux, brown, green, blue, navy blue and black; only turquoise is missing.

There are limitations to the extent that Rapidogens can be mixed. Careful note should be made of the recommendations made by the manufacturer, otherwise the colours may vary considerably because of the cross-coupling possibilities. A standard recipe for printing paste is shown in Recipe 5.9.

With some dyes it might also be advisable to add neutral chromate solutions or urea. The actual recipes should be taken from the pattern card of the manufacturers. Nowadays a starch ether is used almost exclusively as a thickener.

Recipe 5.9

Rapidogen N dye	60 g
Caustic soda (38 °Bé)	15 g
Ethanol	50 g
Water	100 g
Thickener	500 g
Water or thickener to	1000 g

Fixation is carried out in neutral steam at a temperature of 100–102 °C for 5–10 min. By changing the recipe, fixation in hot air or high-temperature steam can be used. Washing can take place on suitable apparatus at full width or in rope form. Generally no particular problems arise. Prints with excellent fastness to wetting and washing, as well as good to very good fastness to light, can be obtained [29–31].

Rapidogen colours can be used in mixtures with solubilised vat dyes and also printed alongside vat, reactive, oxidation and Phthalogen dyes. Rapidogen resists under aniline black, reactive and Phthalogen dyes have also been important.

The increased use of reactive dyes has reduced the importance of these azoic compositions, except for specialist applications, and many commercial products have been withdrawn.

5.3.7 Phthalocyanine colorants

Many pigments and certain fast dyes for cotton have been developed from the important chromophore phthalocyanine (Pc, 5.4). The pigments found wide acclaim in nontextile applications because of their good fastness properties, and are important in the mass coloration and pigment printing of textile fibres. The colours obtainable – bright blue in the metal-free form, turquoise-blue when complexed with copper (5.5)



or nickel (5.6) and green when highly halogenated (5.7–5.9) – exceed in brightness those obtainable from other chromophores. Turquoise direct dyes (5.10, 5.11) are obtained by sulphonation in the benzene rings. Acid dyes (5.12) for complexing with chromium and also cationic dyes (5.13, 5.14) give turquoise-blues. Sulphur dyes (5.15–5.17) and an azoic coupling component (5.18) that gives bright greens have also been marketed. The largest number of these dyes are in the reactive dye ranges, however; 5.19 is an example.

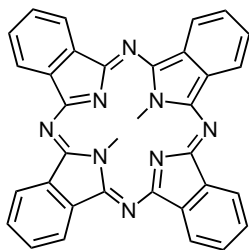

5.4

Metallised Pc
(mainly Cu—Pc and Ni—Pc)

5.5 5.6

Metallised and halogenated Pc
(e.g. Cu—Pc—Cl₁₅, Cu—Pc—Br₆Cl₈, Cu—Pc—Br₁₅)

5.7 5.8 5.9

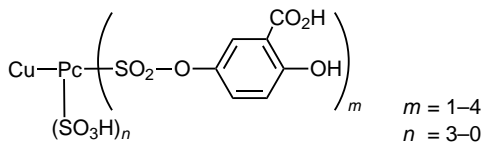
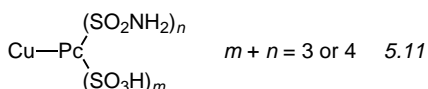
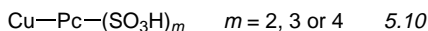

5.12

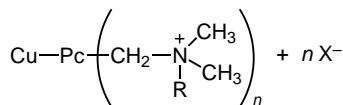

5.13

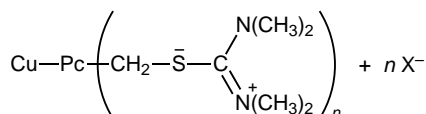

5.14

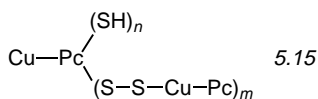

$m + n = \text{max. } 3\text{--}4$

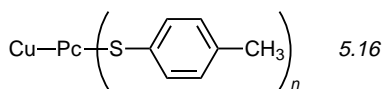

$n = 3 \text{ or } 4$

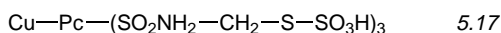

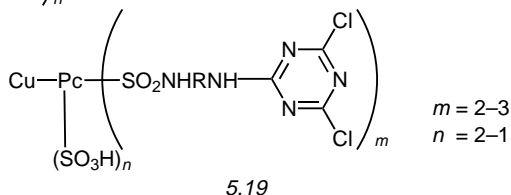
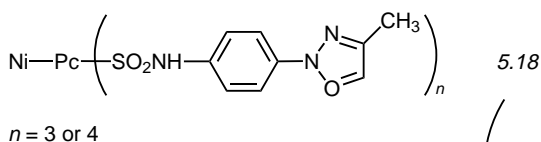

Scheme 5.2 shows the formation of an ingrain colour, inside the fibre, from a Phthalogen colorant.

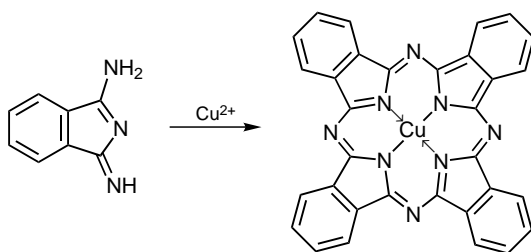

Scheme 5.2

Solvents of the glycol or glycol ether type and also emulsifiers are necessary, because the dye precursor has limited solubility in water. Drying, after the application of the print, must be quick and complete, so that hydrolysis of the 1-amino-3-iminoisoindole is suppressed. Dye formation can be fully completed in hot air at temperatures above 100°C , but it is usually more practical, when other complementary dyes are used, to achieve fixation of the phthalocyanine dye by steaming.

During the washing-off process, it is important to remove all surplus copper or nickel by treatment in an acid solution of sodium nitrite or by using sequestering agents of the ethylenediaminetetraacetic acid type. Anion-active washing agents may be used in the alkaline, boiling wash. Only in this way is the full brilliance and fastness produced.

Variations in the colour, towards green, can be made by replacing the copper completely or partially with nickel, and by making substitutions at the benzene nucleus. In practice aminoiminoisoindolenes substituted by halogens, phenol or methoxy groups have achieved a certain amount of importance because of the brilliant and very fast turquoise and green colours produced. An example of a printing paste is shown in Recipe 5.10.

Recipe 5.10

Aminoiminoisindolene (Phthalogen)	5–60 g
Dissolving medium (polyethylene glycol)	80–140 g
Copper (nickel) complex (Phthalogen K/Ni)	2–15 g
Water	x g
Ammonia (22–25%)	3–8 g
Thickener (e.g. starch ether 10%)	500 g
	1000 g

There are variations depending upon application – for example, when printing on Naphtol AS-prepared fabric, as a resist under aniline black or on polyester/cotton. Recipes are provided by the manufacturers.

In addition to the combinations described above, dye precursors from the tetraazomorphine range can produce very fast browns. From the reaction of aminoiminoisindolene with 2,5-diaminotriazole, or 4,7-dithio-4,5,6,7-tetrahydro-1-amino-3-iminoisindolene, navy blues can be obtained with copper salts and navy blues to black with nickel salts.

Phthalocyanine complex dyes

Solubility can be obtained by forming a heterocyclic macro complex of phthalocyanine, in which quaternary end-groups are linked to a hexavalent copper, nickel or cobalt central atom. Copper and nickel complex dyes (Phthalogen Brilliant Blue IF3GK and Phthalogen Turquoise IFBK) require a given amount of special solvent, mainly polyglycol ether and tertiary amino alcohol. They are fairly stable in the printing pastes and are suitable for resist printing, under or over aniline black, with the addition of zinc oxide. As they can be easily fixed in hot bisulphite baths, they are suitable for resist printing with Variamine Blue. Both are used in yarn dyeing.

The most important Phthalogen complex dye is the cobalt complex Phthalogen Blue IBN. This complex becomes soluble with addition of only 5–10 g l⁻¹ acetic acid 60%. In practice more acid is usually used, for safety reasons and because this product is more popularly used in African printing on naphtholated fabrics, which contain alkali.

The dye can be easily fixed moreover by dry heat, by steam or by reduction. When printing with complex dyes alongside vat dyes, following the two-stage printing method, the dyes are fixed in the reduction treatment. An important characteristic of Phthalogen Blue IBN is that it can be used in mixtures with Fast Colour Salts. Brown to black colours can be produced on Naphtol AS-G preparations, which is important for Africa prints, particularly as they cannot be obtained so easily by any other method [32,33].



5.4 POLYESTER FIBRES

This group of fibres, first marketed by ICI in 1952, has become the most important of all the man-made fibres, because of their desirable properties and relatively low cost.

By far the most important polyester is poly(ethylene terephthalate), but dimethylolcyclohexane esters of terephthalic acid have also been used. So-called basic-dyeable polyester has also been manufactured by incorporation of anionic monomers.

For trouble-free printing, suitable pretreatments must be employed. Water-soluble sizes and spin finishes must be removed from woven and knitted fabrics respectively. Anionic surface-active agents are preferred, as nonionic products cause subsequent difficulties if incompletely removed. The bath should be mildly alkaline and scouring should be carried out between 40 and 80 °C. The removal of paraffin-based lubricants from knitted fabrics is improved by the use of chlorinated hydrocarbon solvents, either as emulsions in the scouring liquor or as nonaqueous solvents in dry-cleaning apparatus.

Heat setting, preferably after scouring, is normally required to ensure fabric stability in subsequent processing and use. By using hot air at 190–210 °C for 20–30 s on a stenter, the fabric dimensions can be chosen for optimum appearance and properties. For fabrics made of bulked yarns a lower temperature must be used, within the region of 150–170 °C.

Bleaching should not normally be necessary, but sodium chlorite can be used where high whiteness levels are desired. Fluorescent brighteners can be applied by exhaustion processes or by the pad–thermofix approach, exactly as in the case of disperse dyes. CI Fluorescent Brighteners 179, 185, 229 and 316 give excellent results at concentrations of 0.25–1% on fibre mass.

5.4.1 Dye selection

On unmodified polyester only disperse dyes are used; cationic dyes can be used on appropriate copolymers, but light fastness is limited.

Azo, anthraquinone, coumarin and quinoline disperse dyes can be used. The commercial products are reduced to optimum particle size by grinding with suitable dispersing agents and finished in powder or granule form (20–40% pure dye) or as liquids (15–30% pure dye). The liquid forms are easier to handle, do not require redispersion and usually give higher colour yields.

Excellent wet fastness properties are obtained, provided that the fixation and aftertreatment processes are correctly carried out. The fibre is hydrophobic and has a high glass transition temperature; thus washing solutions do not penetrate the fibre and dye inside the fibre is removed only with difficulty.

Considerable deterioration of the wet and rub fastness is observed, however, if



significant quantities of nonionic products are left on the fibre surface; products of this type may have been applied as scouring agents, fixation accelerators, softeners or antistatic agents. In this case, any treatment of the goods at temperatures above 140 °C leads to migration of dye (thermal migration) to those areas of fibre surface where the nonionic agents have concentrated. Even if processing at such temperatures is avoided, hot pressing during garment manufacture and consumer use can bring about migration.

Wet fastness tests using nylon 6 as adjacent material are the most critical, and should be employed, since this fibre absorbs disperse dye more readily than does polyester.

Two other important criteria in selecting dyes are the fastness to sublimation and the behaviour during afterwashing. Since dye fixation takes place in high-temperature steam at temperatures up to 180 °C or in dry air up to 210 °C, it is necessary to reject dyes that sublime on to adjacent white fibre under these conditions. Similarly, it is necessary to avoid staining of the ground by unfixed dye during washing at high temperatures by selecting either dyes of low affinity or those that can be destroyed by a reduction clearing treatment.

5.4.2 Print paste formulation

The thickening agent must be selected for adhesion to the fibre, film elasticity and ease of removal, as well as the normal requirements. High-solids-content thickeners, like crystal gum or British gum, give optimum sharpness of outlines, but form brittle films that crack and scatter dye by 'dusting off'. The lower-solids-content thickeners, such as alginates and locust bean ethers, form elastic films and are easily washed out. The latter are most commonly used, often in mixtures with starch ethers. Half-emulsions are also used, but tend to give a less sharp mark and a risk of rubbing off [34,35].

A typical recipe is shown in Recipe 5.11. The acid donor is important because many disperse dyes are affected by hot alkaline fixation conditions. Sodium

Recipe 5.11

Disperse dye	1–200 g
Water	x g
Acid donor	5 g
Fixation accelerator or carrier	0–20 g
Oxidising agent	0–5 g
Thickener	500 g
	1000 g



dihydrogenphosphate is recommended because, unlike some organic acids, it has no corrosive effect on nickel screens and is compatible with alginate thickeners. Destruction of dye by reduction, especially in steaming under pressure, is prevented by adding an oxidising agent, either sodium chlorate or sodium nitrobenzenesulphonate. Depending on the dyes being printed, their concentrations and the fixation conditions, the use of a carrier or fixation accelerator can have a substantial effect on dye sorption.

5.4.3 Fixation

With saturated steam at 100 °C fixation is incomplete unless a carrier is used. Small dye molecules, of low sublimation fastness, diffuse faster and are more efficiently fixed than dyes of higher fastness. By adding 30–60 g kg⁻¹ of a carrier of the *o*- or *p*-phenylphenol type, and steaming for 20–40 min, acceptable fixation is obtained with selected dyes. Suitable dyes include CI Disperse Yellow 54, 93 and 184; Orange 25 and 66; Red 60, 82, 106 and 343; Violet 28; Blue 56, 60, 81 and 287; Brown 4 and 13; Black with mixtures.

Complete removal of the carrier is required if impairment of light fastness is to be avoided, and is only possible by stentering the printed fabric at temperatures above 160 °C.

A wider range of dyes can be used, and deeper colours can be obtained, by steaming under pressure. The absorption capacity (build-up) increases in proportion to the steam pressure, and corresponding temperature, up to 0.35–0.40 MPa (50–60 lbf in⁻²). The colour depth obtained at high pressures cannot be obtained by using longer times at lower pressures.

Steaming for 20–30 min at 0.25–0.30 MPa (36–44 lbf in⁻²) gives very good results, the fixation reaching 90% with selected dyes. The cost of using carriers cannot normally be justified by dye savings when pressure steamers are used.

Recommended dyes include CI Disperse Yellow 93, 126 and 184; Orange 25, 29 and 66; Red 60, 82, 106, 177 and 343; Violet 28 and 40; Blue 56, 60, 81, 154 and 287; Brown 4 and 13; Black with mixtures.

Since the development of high-temperature festoon steamers, high production speeds are compatible with steaming times of 5–20 min and this has become the most important of the fixation methods. Temperatures of 160–185 °C can be used, depending on the dyes and times of treatment chosen. Steam condenses on to the cold fabric, raising its temperature to 100 °C and swelling the thickener film. The condensed water is largely evaporated again during the exposure to superheated steam, but the thickeners are not ‘burnt in’ to the fabric as in dry fixation and the subsequent handle of the fabric is softer [36–38].



Dye selection must take account of the danger of sublimation on to white or pale colour areas. Dyes of poor sublimation fastness should not be used and the selection requires special tests because the sublimation of unfixed dye must be considered in addition to that from the dyed fibre.

It must also be recognised that the risk of staining the white ground depends on the circulation of the heating medium and the movement of the fabric within the steamer, as well as on the temperature and time of treatment.

High-solids-content thickeners (more than 12%) are not recommended as they are difficult to remove in the afterwashing process. Mixtures of alginates with starch ethers, in a ratio between 4:1 and 3:1, have proved successful. Ready-made mixtures of this type are marketed. Where hard water has to be used the addition of polyphosphate sequestrants improves the ease of removal of alginate-based thickeners, and may also increase their compatibility with acid donors and carriers.

Higher colour yields are obtained with medium and deep prints by adding an effective fixation accelerator, usually an ethylene oxide condensate [39].

The following are among the most suitable dyes for high-temperature steam fixation: CI Disperse Yellow 126, 184 and 198; Orange 66, 71, 73 and 80; Red 82, 106, 159 and 177; Violet 31 and 48; Blue 60, 73, 79, 154, 165 and 287; Brown 4 and 13; Black with mixtures.

The thermofixation process also has some significance, the printed fabric being passed through stenters or specially built equipment. The best results are obtained at 200–220 °C, at which temperatures the sublimation characteristics of the disperse dyes used are particularly critical. The time of treatment required may be 40–50 s, but in the absence of a carrier fixation is only in the range of 50–70%. The use of 20–30 g kg⁻¹ of fixation accelerator in the print paste considerably increases the depth of colour obtained.

Texturised polyester is not suitable for dry-heat fixation, because the high temperatures required cause loss of bulk.

Dyes of high heat fastness are required, as recommended for high-temperature steam fixation.

5.4.4 Aftertreatment

Washing is required to remove thickener and unfixed disperse dye. Thorough rinsing first in cold, then in warm water, should be followed by an alkaline reduction treatment at 40–50 °C (Recipe 5.12). Most of the unfixed dye is quickly solubilised or destroyed and, because of the low temperature, the reduction products are not absorbed on to the white polyester. Staining of the ground could occur if the temperature were suddenly raised to 80 °C. A low-temperature soaping liquor and two



Recipe 5.12

Surface-active agent	1 g l ⁻¹
Sodium hydroxide (38 °Bé)	2 ml l ⁻¹
Sodium dithionite (hydrosulphite)	1–2 g l ⁻¹

baths at 70–80 °C are therefore recommended. Finally the goods are rinsed in warm, then cold, water and dried under minimum tension.

A softener or antistatic agent may be applied in the final rinse or by padding before drying. Drying should not raise the fabric temperature above 120 °C, as higher temperatures increase the thermomigration of dye to the surface and the fastness to rubbing deteriorates.

5.5 CELLULOSE ACETATE FIBRES

5.5.1 Secondary acetate

This fibre, produced by partial hydrolysis of fully acetylated cellulose, has been in use since 1921. During pretreatment of acetate fabric it must be remembered that it is sensitive to alkaline hydrolysis, particularly at temperatures above 85 °C, with adverse effects on lustre and stability.

Water-soluble sizes are almost exclusively used, and scouring at 60 °C with anionic or nonionic detergent is normally adequate. Bleaching is rarely required, but either chlorite or an acid reduction bath with CI Fluorescent Brightener 112 or 226 respectively may be used.

A typical print paste recipe is shown in Recipe 5.13. Dye fixation is accelerated by limited amounts of urea, polyethylene glycol derivative or glycerol acetate, but larger quantities may damage the fibre.

Recipe 5.13

Disperse dye	1–150 g
Thickener (locust bean or guar)	500 g
Urea or alternative	0–50 g
Water	x g
	1000 g



Steaming for 10–40 min is carried out in festoon steamers at 100–103 °C or in a star steamer at not more than 35 kPa (5 lbf in⁻²) pressure (see section 8.3). In the latter, it is important that the steamer backcloths are clean because some dyes sublime very readily. Soaping temperatures should not exceed 40–50 °C as many dyes have limited wet fastness.

The following dyes have been used: CI Disperse Yellow 93 and 184; Orange 25, 33 and 80; Red 1, 4, 11, 50, 54 and 343; Violet 8 and 38; Blue 3, 7, 56, 81 and 154; Brown 4 and 13; Black with mixtures.

Because of the poor wet fastness of disperse dyes on this fibre, methods have been developed to apply acid, basic and vat dyes. Swelling agents such as ethanol, benzyl alcohol, urea, thiodiethylene glycol or dicyanoethylformamide must be used. Basic dyes are significant for the particularly brilliant colours that can be obtained. Recipe 5.14 is suitable for use with such dyes. The prints are steamed for 20–30 min in saturated steam at 100–103 °C, then rinsed and soaped in anionic detergent solution at 40 °C. Staining of the white ground can be prevented by careful addition of hydrosulphite.

Recipe 5.14

Basic dye	1–40 g
Thiodiethylene glycol	20–30 g
Acetic acid (30%)	20–30 g
Water	x g
Thickener	500 g
Urea	50 g
	1000 g

5.5.2 Triacetate

Triacetate shows better resistance to heat and alkali than that of secondary acetate, and can be heat-set.

A controlled surface saponification, or S-finish, may be used to raise the safe ironing temperature, provide a permanent antistatic finish and improve fastness to gas-fume fading. Conditions used may be 3.5 g l⁻¹ sodium hydroxide for 1 h at 90 °C, the extent of the saponification being monitored by dyeing samples of the treated material and of the control material with CI Direct Blue 78.

One disadvantage of this treatment is that print colour yields are lower unless pressure steaming is used for fixation.

The whiteness may be improved if necessary by treatment at 90 °C for 30 min in



1 g l⁻¹ sodium hydrosulphite, 2 ml l⁻¹ 30% ammonia and 1% CI Fluorescent Brightener 121.

The choice of dye depends on the fixation method to be used and on the fastness required. Fabric to be pleated requires dyes of high sublimation fastness. Gas-fume fading inhibitors can be added if the dye used has inadequate fastness. The following dyes have been used: CI Disperse Yellow 5, 7, 42, 50, 60, 66, 83, 85, 93 and 126; Orange 13, 53, 55, 66, 67, 106 and 127; Red 5, 11, 72, 76, 82, 90, 91, 132, 134 and 159; Violet 12, 33, 40 and 50; Blue 56, 72, 73, 82, 87, 128, 139, 154 and 284.

Steam fixation at atmospheric pressure and 100–103 °C requires 30–45 min, and maximum depth of colour is not obtained with all dyes. Addition of 5–10 g kg⁻¹ of carrier or fixation accelerator, as with secondary acetate, is essential.

Saturated steam at 120 °C and 0.25 MPa (35 lbf in⁻²) pressure for 30 min gives optimum yield, without carrier, and on S-finish fabric.

For fabric that has not been S-finished, high-temperature steaming for 5–10 min at 180–165 °C in a festoon steamer gives satisfactory results with selected dyes, provided a fixation accelerator is used.

Similar results are obtained using dry heat for 1 min at 190 °C. Navies, blues, blacks and dark browns of adequate wet fastness are difficult to achieve with disperse dyes. Metal-complex dyes may be used for these colours, provided adequate amounts of swelling agent are used, with 30 min steaming at 100–103 °C.

Washing requires care to prevent staining of the ground. When reduction clearing treatments are employed the temperature should not exceed 50 °C, since at higher temperatures the dye inside the fibre can be attacked.

5.6 ACRYLIC FIBRES

Fibres made from linear polymers consisting of at least 85% acrylonitrile units have been given the generic name 'acrylic fibres'. The commercial fibres vary in their properties because other monomers are incorporated to improve dyeability, and both dry- and wet-spinning systems are employed. Small amounts of vinyl acetate, methyl acrylate or acrylamide copolymer increase the accessibility of the fibres, and anionic sites provide affinity for cationic dyes. The similarities between the different fibres are sufficient, however, for a general treatment of the group.

Modacrylic fibres are defined as containing more than 50% acrylonitrile, but less than 85%. The comonomers principally used have been vinyl chloride and vinylidene chloride; these produce fibres that are very difficult to ignite, but which have low softening temperatures.

In pretreatment processes, alkaline conditions should be avoided as discoloration may occur in subsequent drying. Processes for desizing or removal of knitting lubricants



are best carried out at pH 5–6, and at temperatures below the glass transition point. Relaxation and, where necessary, bulking for about 20 min at 90–95 °C may be essential to obtain uniformly stable fabrics. To avoid setting-in creases, it is essential to cool slowly from 80 to about 50 °C, unless the fabric can be handled in open width at low tension.

5.6.1 Dyes

Selected disperse dyes may be used for pale colours, but the build-up and wash fastness attainable are limited.

Basic dyes have proved to be successful for the printing of acrylic fibres and offer brightness and good fastness to light and to washing. A wide range of colours is now available in this dye class, the chromophores being no longer restricted to the classical triphenylmethanes and oxazines. In the classical basic dyes the cationic nitrogen atom is an essential part of the colour-donating chromophore (5.20). Fluctuations in pH can therefore lead to colour changes and in some cases the dye forms a colourless carbinol base under alkaline conditions.

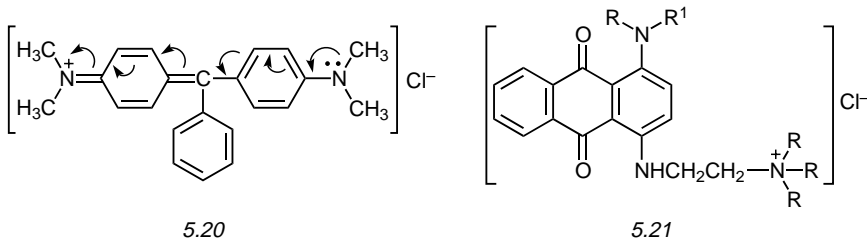

The newer dyes use azo, anthraquinone and phthalocyanine structures with the cationic nitrogen in a side-chain which insulates it from the conjugated double-bond system of the chromophore; compound 5.21 is an example. The colour of these dyes is therefore not so sensitive to alkali, but fixation will only occur under acidic conditions [40].

Fixation of prints of basic dyes on acrylic fibres follows the same mechanism as in dyeing processes. Adsorption on to the fibre occurs readily because of the high affinity of the dye cations for the negatively charged sites on the fibre surface, but diffusion to sites within the fibre is relatively slow. The fibre surface is usually saturated with dye, and therefore the speed of diffusion does not depend on the concentration of dye in the print paste. Dye mixtures may show 'blocking' effects if dyes of different affinity are used.

Dye solubility can have a significant effect on transfer from thickener film to fibre during steaming, and anions which form insoluble complexes with the dye should be excluded from the print paste. Dyes are available in liquid form, incorporating dye solvents. For use where powder brands are employed, Recipes 5.15 and 5.16 give typical stock print paste and reduction recipes respectively. The dye is pasted with the dye solvent and the acetic acid. Hot water (80–90 °C) is poured on to the paste to produce a solution, which is sieved and stirred into the thickener. Finally, the fixation accelerator is added; dicyanoethylformamide has been used successfully. It is extremely important that, during all the drying and fixation processes, the print is at an acid pH. For this reason the addition of a nonvolatile acid to the print paste is absolutely necessary.

Recipe 5.15

Basic dye	30–50 g
Thiodiethyleneglycol	3 g
Acetic acid (30%)	30 g
Hot water	x g
Thickener	500–600 g
Citric acid or ammonium sulphate	5 g
Fixation accelerator	10–20 g
	1000 g

Recipe 5.16

Thiodiethylene glycol	15 g
Acetic acid 30%	15 g
Hot water	450 g
Thickener	500 g
Citric acid or ammonium sulphate	5 g
Fixation accelerator	10 g
	1000 g

To obtain level colours in large area blotch prints, the addition of carboxymethylcellulose has proved successful, since this anionic thickening agent has a levelling effect on the absorption of the cationic dye. Similar effects can be obtained with other anionic materials. A pretreatment with alginate thickeners, sometimes used



to improve the handling of difficult knitted structures, has the same effect. In each case, however, changes in hue and depth of colour are to be expected.

The following dyes have become important in textile printing on acrylic fibres: CI Basic Yellow 28, 29, 51 and 63; Orange 27, 28, 30, 37, 42 and 43; Red 14, 18, 22, 24 and 110; Violet 7, 16 and 20; Blue 1, 3, 147 and 159; Green 4; Black mixtures.

5.6.2 Fixation

The dyes can only be fixed by steaming, and the ion-exchange mechanism presupposes that the dye can dissociate. When fixing water-soluble dyes on synthetic fibres, the importance of constant and correct steaming conditions can never be overstated. Unlike cotton and wool, synthetic fibres hold very little moisture; fluctuations in the moisture content of the steam are therefore not levelled out by changes in fibre regain. Where the steam is too wet the colours bleed, and where the steam is too dry the thickener is not adequately swollen.

The best results are obtained in saturated steam for 20–30 min at 0.1–0.2 MPa (14–28 lbf in⁻²) pressure in a star steamer. For continuous-filament acrylic yarn fabrics, a higher temperature (108–110 °C), at 0.14–0.15 MPa (16–21 lbf in⁻²), is preferred. Rapid agers are unsuitable for lightweight fabrics because of the permanent distortion produced by tension at temperatures well above the glass transition point. It would also be difficult to obtain acceptable colour yields at the usual, slightly superheated, steam temperatures. Tensionless steaming in festoon steamers is preferable, although yields are not as good as in pressure steamers.

It has been suggested that superheated steam may be used but, even when urea or similar hygroscopic substances are employed, the brightness and fixation are poor compared to optimum results [41,42].

Cold water rinsing and soaping at 50 °C, then at 70 °C with 2 g l⁻¹ anionic detergent, are required to ensure good fastness to rubbing and brilliance of hue.

5.7 POLYAMIDE FIBRES

These were the first synthetic fibres produced in commercially significant quantities. The development of knitting machinery led to the production of warp-knitted nylon fabric which could be heat-set, and dyed or printed to give materials with good easy-care properties.

Both nylon 6.6, made by condensation of hexamethylenediamine and adipic acid, and nylon 6, made from caprolactam, are used in substantial quantities. Nylon 11, made from aminoundecanoic acid, is of much lesser interest.



Scouring and setting should normally precede printing, the methods to be employed being selected according to fabric structure, cleanliness and dimensions required. It can be advantageous first to stenter to a width 4% greater than the stable width, if the fabric is to be gummed down directly on to the blanket of a screen-printing machine. This reduces the risk of blistering due to swelling and extension of the first printed areas.

5.7.1 Dyes

Dyes are selected from the ranges of acid, metal-complex acid and direct dyes, according to solubility, print paste stability, washing-off properties, and fastness properties. The use of both thiodiethylene glycol, to improve dye solubility, and thiourea, which acts as both a fibre-swelling agent and a dye-solubilising agent, is recommended. The amount of swelling agent, or carrier, required for printing nylon 6 need be only half that for nylon 6.6. For high colour yield it is essential to include an acid or acid donor, and both ammonium sulphate and citric acid have proved to be suitable [43].

A typical recipe for knitted fabrics of bulked nylon 6.6 is shown in Recipe 5.17. The coacervating agent has a beneficial effect on levelness and surface appearance of

Recipe 5.17

Acid or metal-complex dye	20–40 g
Thiodiethylene glycol	50 g
Water	x g
Thickening (8–14%) containing	500 g
Urea	50 g
Coacervating agent	0–10 g
Antifoam	5 g
Ammonium sulphate (1:2)	30–60 g
	1000 g

carpets and bulked-yarn fabrics. Ensuring the absence of uncoloured surface fibre gives an increase in apparent colour yield.

The choice of thickening agent must be made from products stable at low pH and providing satisfactory adhesion and film elasticity. Modified natural products based on guar, locust bean and karaya gums have been widely used.



5.7.2 Processing after printing

It is usually important that saturated steam is used for print fixation. By careful selection of dyes the steaming time required can be shortened, but 20–30 min is recommended at 100–103 °C. With many dyes, improved yields may be obtained by using a pressure steamer at 35–105 kPa (5–15 lbf in⁻²) excess pressure. High-temperature steaming, or thermofixation, may also be used for a few dyes.

During washing-off, great care must be used to avoid staining of unprinted white ground areas and pale printed areas. The high affinity and rate of adsorption of acid dyes, especially on nylon 6, make it essential to plan the washing process, bearing in mind the factors affecting dye sorption.

Because dye affinity is much lower under alkaline conditions, even the initial cold rinsing of the prints is preferably carried out in 1 g l⁻¹ sodium carbonate solution. Further washing may be at 40 °C, then at 60 °C with 1 g l⁻¹ sodium carbonate and 1.5 g l⁻¹ of a mildly cationic auxiliary agent to complex the anionic dye and hold it in the bath. Alternatively, an anionic retarding auxiliary may be used under acid conditions, but it may be necessary to use up to 6% on fibre mass of such an agent. Ideally, total washing times of 30 min are required.

Final rinsing in cold water may be preceded by a ‘backtanning’ aftertreatment with a synthetic tanning agent (Syntan), to improve the fastness to washing at temperatures up to 80 °C. Such aftertreatments are, however, less frequently used on prints than on dyed fabric because of adverse effects on the white ground, in addition to the 15 min extension of an already lengthy washing procedure.

The following acid dyes have been used: CI Acid Yellow 49, 79 and 222; Orange 95; Red 274, 276, 337 and 360; Violet 42 and 103; Blue 113, 205, 220, 221, 264 and 313; Green 81 and 84; Black 172. Suitable metal-complex dyes include CI Acid Yellow 232; Orange 107 and 166; Red 279 and 414; Blue 199 and 335; Brown 413 and 415; Green 91; Black 140 and 220.

5.8 PROTEIN FIBRES

Because the desirable appearance and properties of the natural protein fibres exceeds anything achieved by the synthetic-polymer fibres, they can be expected to maintain a secure place among the higher-priced luxury goods. Individually they are:

- sheep’s wool (by far the most important product)
- mohair (wool of the angora goat)
- alpaca (wool of the llama)
- cashmere (wool of the cashmere goat)
- camel hair



- mulberry silk (the most common natural silk)
- tussah silk (wild silk).

Since all are protein fibres, polypeptide chains are common to them all; however, in wool there are tangled side-chains, whereas the polypeptide chains of silk are elongated and have few polar side-groups, so that they absorb less acid. The presence of cystine sulphur bridges is also characteristic of wool.

These fibres can be broken down by hydrolysis into a mixture of numerous amino acids, the composition of which is characteristic of each fibre. The amphoteric nature of the protein fibres is due to the presence of amino and carboxyl groups, providing sites for acid and basic dyes as well as reactive and direct dyes. The formation of metal complexes, involving the fibre and dyes of suitable configuration, is also clearly possible.

Some other properties of these materials are also important for dyeing and printing. Protein fibres are particularly sensitive to the effect of alkali, to rubbing and to temperatures above 120 °C, which cause deformation, yellowing and impairment of handle. On the other hand, wool and silk are remarkably stable in the presence of dilute acids.

Wool has a well-known tendency to felting. Chlorination, however, changes the scaly layer of the wool fibre in such a way that the material wets out and swells more easily. The scales lie flat on the cortical layer, the wool no longer felts as readily and has increased lustre. Unfortunately it is extraordinarily difficult to carry out this process uniformly and irregular uptake of dye can result. Two approaches have been used to improve the uniformity of wet chlorination. Firstly, nitrogenous auxiliary agents may be used in the chlorination bath, which temporarily bind the free chlorine in the form of chloramines; these then react slowly with the wool (an example of this technique is the Melafix method, CGY). Alternatively, the sodium salt of dichloroisocyanuric acid is added (such as Basolan DC, BASF) and is slowly hydrolysed, liberating hypochlorous acid.

These processes, if carried out correctly, bring about such a substantial improvement in colour depth and brilliance, regardless of which dyes are used, that almost all wool piece goods for printing are pretreated in this way.

Natural silk also requires pretreatment. The silk moth (*Bombyx mori*) produces a double thread made of the protein fibroin, which is stuck together with a second secretion, sericin (silk gum). Textiles made from untreated 'raw silk' are coarse and hard to the touch. As a rule they are therefore 'degummed', by washing them in a soap solution. The resulting colloidal suspension of sericin in the soap, the so-called 'degumming liquor', acts as an excellent protective colloid and levelling agent in silk dyeing. After this treatment the material has improved lustre and absorptive capacity for dyes, and can be printed as described below, in principle, exactly as wool.



5.8.1 Acid, basic and direct dyes

As already mentioned, these dyes are all theoretically suitable for printing wool and silk; however, application is mainly limited to acid dyes. Basic dyes can provide extraordinary brilliance in some cases, but do not show adequate fastness. Acid dyes must also be selected to obtain acceptable light and wet fastness for each end-use, in addition to the desired brilliance of hue. This applies both to direct and to discharge printing.

The less soluble dyes of these classes need urea or thiourea to assist solution along with auxiliary solvents, such as thiodiethyleneglycol, and hot water. When printing wool, glycerol may be used to reduce the adverse effect of superheat in the steam during fixation; with silk, however, the addition of glycerol can cause 'flushing' problems.

Locust bean or guar derivatives are used as thickening agents, either on their own or in mixtures with cold water-soluble British gum. Crystal gum is used for printing silk, rather than tragacanth and mixtures of tragacanth with British gum or gum arabic, which were formerly the main thickening agents. Thickeners of high solids content are used for fine effects and outlines, whereas products of low solids content are preferred for larger areas because of their better levelling effect and the reduced possibility of crack marks occurring after printing.

The printing pastes contain an acid donor for fixation of the dye. This may be ammonium sulphate, ammonium tartrate, oxalate or even in some cases acetic acid or glycollic acid. Small amounts of sodium chlorate are added to counter the reductive effect of wool, and possibly the thickeners, during steaming. In the case of dyes 'sensitive to steaming', the addition of sodium chlorate is essential. Defoamers and printing oils are also usually necessary for smooth prints with sharp outlines. Coacervate-forming surface-active auxiliaries have proved successful for the prevention of 'frosting' effects on wool, especially where chlorination was not adequate and for particularly voluminous materials.

Relatively long steaming times of 30–60 min are usually needed to fix acid dyes on wool or silk. The most brilliant and fast prints can only be obtained in saturated steam fixation at 100–102 °C. For this reason it is most important to avoid overdrying the goods after printing (Chapter 8). Wool is even 'spray damped' sometimes before steaming, or put into artificially moistened steam. This, however, means that there is a danger of drop formation. In batch steamers, condensation spots and uneven fixation are less likely if a procedure of alternate steaming and evacuation is used. Festoon steamers, which allow sufficiently long steaming times, are often used.

The final wash of the printed goods usually takes place on the winch beck, but it can also be undertaken in one of the washing machines designed for knitted goods. Wool and silk should be treated very carefully, with as little mechanical strain as



possible. To prevent the staining of unprinted areas, as well as to counter the risk of bleeding, the use is recommended of polycondensation products of aromatic sulphonic acids, such as Mesitol HWS (BAY) or Erional NWS (CGY). These products improve the wet fastness on wool considerably. To obtain the best results, 5–6% on the mass of the goods should be used at 60 °C in an acetic or formic acid bath. Treatment for approximately 20 min in the final rinsing baths is required.

5.8.2 Metal-complex acid dyes

These dyes, both 1:1 and 1:2 complexes, offer higher fastness than acid dyes, particularly light fastness, but somewhat duller colours. The way in which metal-complex dyes are applied hardly differs at all from the method used for acid dyes, except that these dyes do not require the use of an acid or acid donor. At low pH, in fact, not only is the stability of the paste diminished but there is also a tendency for the dyes to aggregate and to give rise to specks. At the same time acid donors can adversely affect the levelness of prints, and these high-affinity dyes often give levelling problems in blotch printing anyway.

Otherwise both the dissolving process and the choice of print thickener, as well as fixing and afterwashing are the same as with acid dyes. It is possible, therefore, to mix acid and metal-complex dyes, but printing should be without acids or acid donors.

5.8.3 Reactive dyes

These products form true chemical bonds with the SH, NH or NH₂ groups in the polypeptide chains, in acid media (pH 3–5) at 80–100 °C. Such dyes can provide prints of good fastness and brilliant colours.

Additional expenditure is unavoidable when using these dyes, but this is justified by the high demands made, especially on goods which bear a Woolmark, as well as the durability of articles produced from these fibres. There is practically no difference in the printing procedure from that for metal-complex dyes, except that some acid donor is necessary in the paste to guarantee acidity. The fixation times can be reduced to 10–20 min in saturated steam at 100–102 °C. During afterwashing of the print, however, the degree of fastness expected can only be obtained if the unreacted dye on the fibre is removed completely. For this reason, after rinsing, the goods must be soaped in several baths at increasing temperature (40–60–80 °C), with 2 g l⁻¹ disodium hydrogenphosphate, enough ammonia to bring the pH to 9, and an anionic washing agent. In consequence, this energetic washing process does not allow any other class of dye, apart from reactive dyes, to be used in the print paste, and as far as printed goods are concerned, wet aftertreatment of this sort is possible only on nonfelting goods – that is, almost exclusively on chlorinated wool.



Recipe 5.18 indicates some general formulations for use on protein fibres.

Recipe 5.18			
	<i>Acid/g</i>	<i>Metal-complex/g</i>	<i>Reactive/g</i>
Dye	x	x	x
Urea	50	50	50
Thioethylene glycol	50	50	50
Water	y	y	y
Thickener	approx. 500	approx. 500	approx. 500
Ammonium sulphate 1:2	60		
Formic acid 85%			10
Sodium chlorate 1:2	15	15	15
	1000	1000	1000

5.9 POLYESTER/CELLULOSE FIBRE BLENDS

In recent years polyester and cellulose blends have become increasingly important, especially polyester:cotton mixtures in the ratios 50:50 and 67:33. Polyester fibres are also mixed with regenerated cellulose fibres in similar ratios. The popularity of these blends stems from the desirable balance of physical properties and the comfort in wear of articles made from them, such as shirts, blouses and other outer clothing.

Several techniques, dyes and dye combinations can be used for the printing of polyester/cellulose blends in the form of woven or knitted goods. Many variations have been tried out in practice and good results obtained, but always with some difficulty or undesirable complication [44,45]. The various processes described below refer to polyester/cotton mixtures; where necessary, information is given for mixtures of polyester and regenerated cellulose.

5.9.1 Processes using a single class of colorant

Pigment printing

Pigment printing is not complicated and does not present the difficulties that can arise when printing mixtures consisting of two different fibres, as one pigment colours both fibres and to the same hue. Moreover, no expensive treatment is required either before or after printing. Neither do the prints have to be washed. Most printed polyester/cellulose fabrics are therefore pigment-printed.

The process is essentially simple and safe. Pigments cover absorption irregularities in the substrate, and they can be used on substrates having different ratios of the two



fibres, as each fibre is equally covered by pigment. Slight variation in the recipe is required to achieve optimal fastness with different mixture ratios. The prints show very sharp outlines and the colour possibilities are almost unlimited. As no washing-off is required, it is also possible to print very delicate materials. Production costs are low.

There are certain offsetting disadvantages to pigment printing, however. The amounts of binder and crosslinking agent required for dark colours are so large that the handle of the goods is impaired. Application of pigment and binder to the surface of the fibres also reduces the natural lustre in the printed areas of the fabric.

Abrasion marks occur during wear on collars and cuffs of clothes made of pigment-printed polyester/cotton, especially on blouses and shirts. This has been shown to be caused by the action of body fat on the print. Abrasion at creases also occurs, especially if this kind of clothing is machine-washed. Dry-cleaning several times with chlorinated hydrocarbons is also likely to reduce the colour depth.

Insoluble azo colours

Certain CI Azoic Compositions which can be fixed under neutral conditions can be fixed on the cotton part of the blend and then given a later heat treatment during which some of the azo dye formed can diffuse into the polyester fibres. The fastness properties obtained are generally satisfactory. This process, however, is limited to a few hues. Polyester/cotton blends in the ratio 50:50 yield better results than mixtures in which polyester predominates.

Selected vat dyes

Chronologically, selected vat dyes of low r.m.m. were the first to be used for the printing of polyester/cotton. The dye is first fixed on the polyester, in hot air for 45–60 s at 200–210 °C. The vat pigment dissolves in the polyester part of the blend, acting like a disperse dye. The vat dye is then fixed on the cotton, using a two-stage fixation process. The Polyestrene dyes (HOE) were a small range of vat dyes selected for use in this way. The prints had very high fastness, but the brilliance and depth of colour was restricted.

Selected disperse dyes

In 1972 it was shown that selected disperse dyes (Dybln dyes, DUP) could be applied to polyester/cotton with the help of water-miscible high-boiling solvents, in hot air at temperatures of at least 210 °C [46]. The function of the solvent is to maintain the cotton in the swollen state and dissolve the disperse dye during fixation, so that the dye



can enter the fibre. Washing then removes the solvent and leaves insoluble dye within the cotton. The process is impressively simple in that only one class of dye is used, with one-stage fixation followed by a simple washing process.

When the process was introduced, however, few suitable dyes were available; a very low solubility in water was essential. There were no clear, brilliant red and blue dyes in the original range. A further disadvantage was that the fixing temperature needed to be very high, otherwise fixation was incomplete. Fixation is, moreover, less satisfactory in the superheated steam festoon steamers that are now widely used in print works. Blends with regenerated cellulose cannot be printed because the solvent swelling effect is inadequate. The printing paste had to contain about 10% solvent, which increased costs. The division of dye between cotton and polyester depended on the amount of solvent, and on the volatility of the dye. Finally, the fastness became less satisfactory on blends containing larger percentages of cotton; the process is limited to blends of ratio 67:33 or higher.

A range of similar dyes, Cellestren (BASF), was introduced, but has been withdrawn.

5.9.2 Processes using two dye classes

In processes using two dye classes the component for the polyester portion is always a disperse dye, whereas the dye for the cotton can belong to any one of several classes. In textile printing (in contrast to dyeing), only mixtures of disperse and reactive dyes have achieved significant success. For the sake of completeness, and because requirements vary with time and place, the other possibilities will also be described.

Pigments and disperse dyes

The limitations that affect pure pigment printing of polyester/cotton have already been discussed. By adding selected disperse dyes to the pigment printing paste, it is possible to get dye into the polyester fibres. This reduces the loss of colour and appearance on abrasion marks during wear and washing. Some dye manufacturers offer ready-mixed blends of pigment and disperse dyes. When using this kind of product, a certain amount of the disperse dye remains in the binding film. Those prints which require to be fast to dry-cleaning must therefore be given a controlled clearing process before they are sold to the customer. This also means another drying process, and careful selection of pigments for resistance to reduction. The simplicity of pigment printing is lost because of the additional operations. In some markets, however, these mixtures have met with limited success.



Azoic compositions and disperse dyes

After application of the dye mixture, neutral or acid steaming effects fixation of the azoic dye on the cotton portion of the blend. The disperse dye is then fixed on the polyester fibre using hot air. Most of the azoic dyes are susceptible to reduction, so that mild clearing conditions must be applied, and limitations on colour depth or rubbing fastness accepted.

Vat and disperse dyes

The two components can be mixed in the colour shop or they can be obtained from dye manufacturers as a ready-mixed product. The procedure for printing is the same as that described in section 5.9.1 for vat dyes alone. The goods are printed in the absence of alkali, treated so as to fix the disperse dye, and then subjected to a two-stage fixation in order to fix the vat dyes on the cotton. The pad–steam fixation stage is a reductive treatment, which removes much of the unfixed disperse dye, and makes the final washing of the print is easier. Prints produced by this method have very good fastness properties.

The vat and disperse dye combination has secured a safe place for the dyeing of polyester/cotton, but has not been introduced into printing to a great extent.

Soluble vat and disperse dyes

Selected vat leuco ester dyes, such as Anthrasols (HOE), and selected disperse dyes can be prepared as separate printing pastes. The two printing pastes are then mixed in a ratio of 1:1. After printing, the disperse dye is fixed in hot air and then the soluble vat dyes are oxidised during washing, using the same method as the nitrite process (section 5.3.4). The combination has only secondary importance because the costs are high and technical merits inadequate.

Reactive and disperse dyes

The application of disperse and reactive dyes in textile printing has met with worldwide interest. This combination can be fixed in a single process, as in pigment printing. The problems that may arise are fewer than with other dyes and this combination offers more scope as regards the colour range that may be produced. Ready-mixed dye blends are used and recommendations are also made for the mixing of disperse and reactive dyes:



- ready-mixed dye combinations, such as Drimafon R (S), Procilene (Zeneca), Remaron Printing Dyes (HOE) and Teracron (CGY)
- recommended separate disperse and reactive dyes, such as Dispersol PC–Procion PC (Zeneca).

When choosing dyes for this kind of combination, it is necessary to take into consideration the two different kinds of fibre in the substrate to be printed, and then to consider it as a blend. The reactive dye should give as high a degree of fixation as possible, since it plays an important part in obtaining full depths on the fibre blend. This is evident when unmercerised blends are printed.

There will, of course, be significantly more unfixed dye than for single-fibre fabrics. This will result in additional problems when washing the print. Unfixed disperse dye that cannot be removed in cold water, or solubilised in hot alkali, is likely to stain unprinted polyester in the hot washing stage. Finally, when selecting from the two different dye classes, one should consider the possible reaction of these dyes with each other and possible reactions with the chemicals and auxiliary agents used for printing and washing.

The following points must be kept in mind:

- washing the print should present as few problems as possible
- build-up of dye on the two fibres should be similar in yield and hue, producing as solid a colour as possible
- no reaction should take place between the disperse and the reactive dyes.

These points are discussed below.

Washing the print: Strongly alkaline washing treatments, as recommended for Drimafon and Dispersol–Procion PC dyes, have a particularly good clearing effect. The disperse dyes used possess alkali-sensitive groups, such as ester groups; in a strongly alkaline medium these dyes are solubilised and no longer stain polyester fibres [47]. Special nonionic washing agents may assist the washing effect substantially [48]. It must also be possible to wash off the reactive dyes used in the dye combination both quickly and completely, and the reactive dye must form a dye–fibre bond of high stability in the presence of alkali.

Build-up of dye: The build-up properties of disperse and reactive dyes on the two fibre components differ from one dye to another, and must be taken into account when selecting dyes. Just as important is the maintenance of the correct proportion of reactive to disperse dyes, to ensure that the ratio of the fibres to be printed does not significantly influence the hue and washability.



The stability of the dye–fibre bond is important, particularly when printing pale colours, for which alkaline print pastes are used because one-stage fixation is practicable. To ensure that the print can be easily reproduced, appropriate reactive dyes must be chosen.

Reaction between disperse and reactive dyes: When the fixation takes place at high temperatures in the presence of sodium bicarbonate, there is a danger that reactions may be take place between the reactive and the disperse dyes – for example, with amino groups. To avoid this, dyes must be selected with extreme care. The amount of alkali in the thickening agent should also be kept at a level that effects minimum decomposition of disperse dye.

The use of sodium formate, instead of bicarbonate, has been shown by Hoechst to give better colour yields, because the alkalinity required for the fixation of reactive dye is developed only at a late stage in the process. The use of reactive dyes fixed in acid conditions, such as the Procion T (ICI) dyes, achieved optimum yield of fixed disperse dye. Mildly acid conditions are ideal for disperse dye application. (These dyes have, however, been withdrawn.)

Urea is necessary for optimal fixation of reactive dyes in hot air or superheated steam. Urea also reduces the yellowing of cellulose under hot, dry, alkaline conditions, and it thus helps in the production of bright colours. It acts as a solvent for the reactive dye and accelerates migration of the dye from the thickener film into the cellulose fibre. When using some reactive dyes of good solubility, 50 g kg⁻¹ urea is sufficient. If higher amounts are used, the disperse dye stain on cotton is increased and the yield of fixed reactive dye may decrease, especially with dyes of the vinyl sulphone type.

When printing polyester/cotton fibre blends with combinations of disperse and reactive dyes, it is important that the goods undergo a suitable pretreatment process (Table 5.2). These differ from the usual processes for pretreatment of cotton in that the singeing process is delayed.

Singeing in the presence of sizing agents can cause fibre damage. Careful drying is necessary, because the dye absorption capacity of cellulose fibres can be adversely affected by overdrying. Regenerated cellulose fibres can present problems with regard to their absorption of reactive dyes, depending upon their origin. Correct pretreatment of regenerated cellulose blends is essential.

The safest method is to give the fibre blend an alkaline pretreatment with caustic soda of approximately 6 °Bé. This opens up the fibre structure and improves dye fixation. Should the singeing and bleaching be unnecessary because of the composition of the substrate, alkaline pretreatment should follow the desizing of the goods.

The mixtures of reactive and disperse dyes available on the market are produced in such a way that they can be sprinkled directly into the thickening paste. This applies



Table 5.2 Pretreatment processes for polyester/cellulose blends

Polyester/cotton	Polyester/viscose
Desizing	Desizing
Mercerisation	Drying
Drying	Singeing
Singeing	Alkaline pretreatment
Bleaching	Bleaching
Drying	Drying

both to printing pastes on a pure alginate base and to those on a half-emulsion base. When producing a printing paste containing alkali-sensitive disperse dyes it is important to ascertain whether the reaction of the alginate thickener is neutral before processing, so that the correct amount of alkali is present in the printing paste. The thickening agent must be able to withstand the very high temperatures used for fixing the dyes. A complexing agent for calcium, such as hexametaphosphate, should be added to the printing paste, to ensure that the thickener can be washed off quickly. Fixation accelerators may be preferred as alternatives to urea, which can sublime on to the machinery.

Prints with disperse and reactive dye combinations are fixed in a one-stage procedure, in either hot air (30–70 s at 190–205 °C) or superheated steam (6–8 min at 175–180 °C).

Washing-off the print

As far as the reactive dye in the combination allows, an alkaline washing process is used. This kind of washing process can consist of five steps, and a suggested procedure is given in Recipe 5.19.

The high washing temperatures are desirable in order to achieve good washing effects. This washing process can be applied in open width or in rope washing machines. The washing time for continuous washing depends upon the weight and density of the goods. The efficiency of the washing effect can be tested by acetone extraction. A 4 × 4 cm sample is cut from a corner of the print where the colour is strongest; it is placed in a test tube containing 5 ml of acetone and shaken for a short time. If washing has been satisfactory, the acetone remains unstained. Unfixed disperse dye which has not been washed off dissolves in acetone; if the acetone sample is strongly coloured, then the washing process must be repeated. The acetone test also makes it possible to assess the general level of fastness to be expected from the print.



Recipe 5.19

		<i>Auxiliaries</i>
Step 1	Rinsing (cold)	–
Step 2	Washing at 40–60 °C	3 g l ⁻¹ complexing agent 3 g l ⁻¹ soda ash 3 g l ⁻¹ caustic soda 38 °Bé 2 g l ⁻¹ washing agent (nonionic)
Step 3	Washing at ca. 95 °C	3 g l ⁻¹ complexing agent 3 g l ⁻¹ soda ash 3 g l ⁻¹ caustic soda 38 °Bé 2 g l ⁻¹ washing agent (nonionic)
Step 4	Rinsing at ca. 95 °C	
Step 5	Rinsing (cold)	0.5 ml l ⁻¹ acetic acid 60%

If the goods need to be washed again, it is advisable to divide the process up, so that the goods are batched in an alkaline state prior to the repeat process.

In the finishing stage, care should be taken when choosing the catalyst for resin finishing of the fabric. Catalysts that are activated at temperatures of 120–125 °C are to be preferred. At these temperatures thermal migration (the desorption of dye from the fibre to the surface) of disperse dyes is not significant. When the rub and wet fastness values deteriorate after resin finishing, thermal migration is a likely explanation.

REFERENCES

1. N S Cassel, *Amer. Dyestuff Rep.*, **49** (1960) 184.
2. K Craemer, *Melliand Textilber.*, **35** (1954) 523.
3. A C Nuessle, *Chem. Ind.*, 1966, 1580.
4. W Schwindt *et al.*, *Rev. Prog. Coloration*, **2** (1971) 33.
5. H Berlenbach, *Dyer*, **140** (1968) 693.
6. W Schwindt, *Melliand Textilber.*, **50** (1969) 670.
7. J Klein, *Chemiker Z.*, **89** (1965) 299.
8. R Muller and W Schwindt, *Melliand Textilber.*, **49** (1968) 1325.
9. H Wigger, *Textil Praxis*, **44** (1988) 45.
10. W Berlenbach, *Melliand Textilber.*, **53** (1972) 207.
11. S Heimann and K Dachs, *Melliand Textilber.*, **53** (1972) 580.
12. P Rasche, *Textilveredlung*, **10** (1975) 31.
13. A Johnson in *The theory of coloration of textiles*, 2nd Edn, Ed. A Johnson (Bradford: Dyers' Company Publications Trust, 1989) 503.
14. C V Stead, *Rev. Prog. Coloration*, **1** (1969) 23.
15. R R Davies, *Rev. Prog. Coloration*, **3** (1972) 73.
16. R Schwaebel *et al.*, *Bayer Farb. Rev.*, **13** (1967) 1; **26** (1975) 48.



17. P Dussy, *Text. Chem. Colorist*, **2** (1970) 51.
18. W Badertscher, *Ciba Rev.*, (1) (1969) 54.
19. B Glover and J A Hughes, *J.S.D.C.*, **87** (1971) 371.
20. FR Alsberg *et al.*, *Dyer*, **141** (1969) 151.
21. K Roth and W Gottling, *Textil Praxis*, **45** (1989) 650.
22. D Hildebrand and W Beckmann, *Melliand Textilber.*, **49** (1964) 1138.
23. G Dillmann, *Melliand Textilber.*, **43** (1962) 265.
24. A Johnson in *The theory of coloration of textiles*, 2nd Edn, Ed. A Johnson (Bradford: Dyers' Company Publications Trust, 1989) 477.
25. *The chemistry of synthetic dyes and pigments*, Ed. H A Lubs (New York: Reinhold, American Chemical Society monograph) 181.
26. H Gutjahr, *Bayer Farb. Rev.*, **10** (1965) 53.
27. H Gutjahr, *Bayer Colorist*, **7** (1958) 15.
28. E Fees, *Textil Praxis*, **3** (1975) 313.
29. H Gutjahr, *Bayer Farb. Rev.*, **11** (1966) 44.
30. J Eibl, *Bayer Farb. Rev.*, **11** (1966) 62.
31. R Jomain, *Teintex* (1954) 253.
32. J Eibl, *Melliand Textilber.*, **45** (1964) 789.
33. J Eibl, *Bayer Farben Rev.*, **24** (1975) 47.
34. FR Alsberg and P R Dawson, *Textilveredlung*, **8** (1973) 365.
35. H Dahm, *Bayer Farben Rev.*, suppl. (1974).
36. FR Alsberg, *J.S.D.C.*, **90** (1974) 111.
37. R Hofstetter, *Text. Chem. Colorist*, **5** (1973) 172.
38. M Thissen, *Melliand Textilber.*, **53** (1972) 573
39. U Karsunsky and M Thissen, *Melliand Textilber.*, **53** (1972) 577.
40. W Kuhnel, *Melliand Textilber.*, **51** (1970) 325.
41. G Meyer, *Melliand Textilber.*, **51** (1970) 1341.
42. F Hoch and R Manuele, *Ciba-Geigy Rev.*, (2) (1973) 34.
43. H Manderla, *Bayer Farben Rev.*, **8** (1964) 32.
44. B Glover, *Rev. Prog. Coloration*, **8** (1977) 36.
45. B Hart, *Text. Chem. Colorist*, **2** (1970) 253.
46. *Amer. Dyestuff Rep.*, **60** (1971) 25.
47. FR Alsberg, *Textil Praxis*, **4** (1976) 649.
48. R Schwaebel, *Textilveredlung*, **10** (1975) 433.



CHAPTER 6

Discharge, resist and special styles

Clifford Berry and John G Ferguson

6.1 INTRODUCTION AND DEFINITIONS

Discharge and resist styles have been important since the earliest days of textile printing. Knecht and Fothergill gave an excellent account of the many processes, often developed with considerable ingenuity, that provided a wide range of effects without the advantages of modern dyes [1]. In recent years, modern techniques have made the use of direct printing practicable for many more designs and reduced the necessity of using these styles, but they will always be of significance because the effects obtained are often different and aesthetically superior.

In the direct printing style, the final effect is obtained in one operation, with the proviso that fixation and washing may also be necessary. Originally the term 'direct' indicated that no prior step of mordanting or following step of dyeing was required. In the discharge style, the fabric must first be dyed with dyes that can be destroyed by selected discharging agents. The discharge paste is printed on to the dyed fabric and, usually during subsequent steaming, the dye in the pattern area is discharged. A white discharge is thus produced. It is also possible to add a discharge-resistant ('illuminating') dye to the discharge print paste, to produce a coloured discharge. The area of dyed fabric surrounding the pattern areas is described as the 'ground', because it is a background from which the illuminating colours (often called head-colours) shine. This is especially true when the ground is black, when the colours seem to have extra brilliance. The use of the term 'ground' is naturally extended to describe the dyed fabric before printing.

Resist printing can be used to produce similar effects, but in this style the fabric is first printed with a resist agent and then dyed. Ground colours can, therefore, be obtained with nondischargeable dyes. Resist mechanisms may be chemical or physical, the maximum effectiveness being ensured by using a mixture of both types of resist agent. A physical resist inhibits absorption of dye, and a chemical resist inhibits fixation. Coloured resists require the addition to the print paste of dyes or pigments



that are satisfactorily fixed in the presence of the resist agent, either before the fixation of the ground colour or during the process.

If the ground colour is not too dark, it may be that the required effect is obtainable by 'overprinting'. This is simply direct printing on to a pre-dyed fabric. Tone-on-tone effects, which use colours of similar hue, are often produced in this way, but contrasting colour combinations are also possible. For example, blue dyes may be printed on to a yellow fabric to obtain green areas. Overprinting requires no elaboration, but discharge and resist styles must be considered in more detail if the full range of possibilities and problems are to be appreciated and understood.

6.2 DISCHARGE PRINTING

With any industrial process there must be sound technical and commercial reasons for its conception and continuation. In the case of discharge printing, the following considerations determine the usefulness of the process compared with other printing techniques.

1. Printed materials with large areas of ground colour can be produced, the depth, levelness and penetration of which would be difficult, if not impossible, to obtain by a direct printing process.
2. Delicate colours and intricate patterns can be reproduced on grounds of any depth, with a clarity and sharpness that have become the hallmarks of this style. Intricate white patterns lose their crispness if left as unprinted areas in a direct, blotch print, because the print paste spreads unequally in different directions. In addition, a coloured motif fitted into a blotch print either leaves unprinted white margins or forms a third colour where fall-on occurs. In some cases such effects are acceptable, but they can be eliminated by using the discharge technique.
3. The extra processes required and the additional costs of discharge pastes mean that production costs are higher, but the aesthetically superior results give the product a higher value and enable profit margins to be maintained or even improved. The higher costs of discharge printing are often offset when applied to long-lasting designs used for scarves, ties, cravats and dressing gowns.

As already indicated, in discharge styles the pattern is produced by the chemical destruction of the original dye in the printed areas. The discharging agents used can be oxidising or reducing agents, acids, alkalis and various salts. An early and, one might say, classical example is the discharge printing of cotton dyed with indigo, the characteristic colour of which can be destroyed either by oxidation or reduction (Scheme 6.1).

In the former, an oxidising agent, such as a thickened 10% solution of sodium



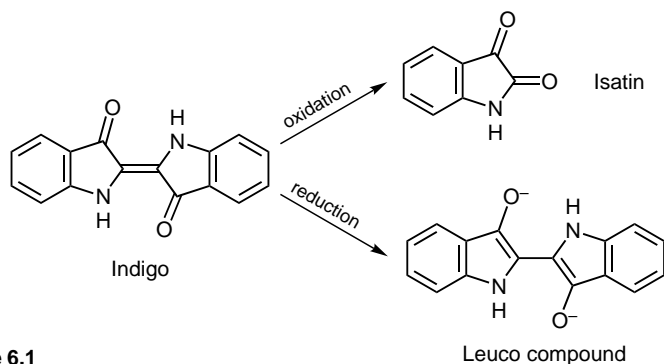

Scheme 6.1

dichromate, is printed on to the indigo-dyed material and dried. When this is passed through a hot bath of sulphuric and oxalic acid, chromic acid is liberated and the indigo in the printed areas is oxidised to isatin. The oxalic acid reduces any excess chromic acid which might be formed and which would otherwise gradually discharge the ground colour. Since isatin is soluble in alkali, the final step is to run the fabric through an alkali bath – in an open soaper, for example – whereupon the isatin is removed to give a white discharge pattern. The main problem with this process is the adverse effect of the oxidising agent and the acids on the cotton substrate, which can easily be tendered under these conditions.

To produce a white discharge effect by reduction, the indigo-dyed fabric is printed with a thickened paste containing a stabilised reducing agent, together with sodium carbonate, anthraquinone and Leucotrope W (6.1). When the dried print is steamed, the reducing agent is activated and reduces the indigo to its leuco (colourless) form. The Leucotrope W combines with the leuco compound to form an alkali-soluble orange product which will not reoxidise, and which can be washed out to give a good white. Zinc oxide can also be added to assist the discharging action and to give a white pigmentation effect. If Leucotrope O is used instead of Leucotrope W, an insoluble orange complex is formed which remains fixed to the fibre and is used in some styles to give a coloured discharge (Scheme 6.2).

These examples indicate the importance of an adequate knowledge of the structure and properties of the dye and print paste ingredients, so that the most effective

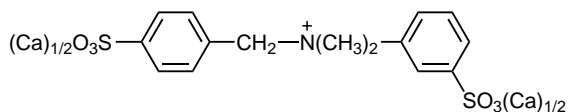

6.1

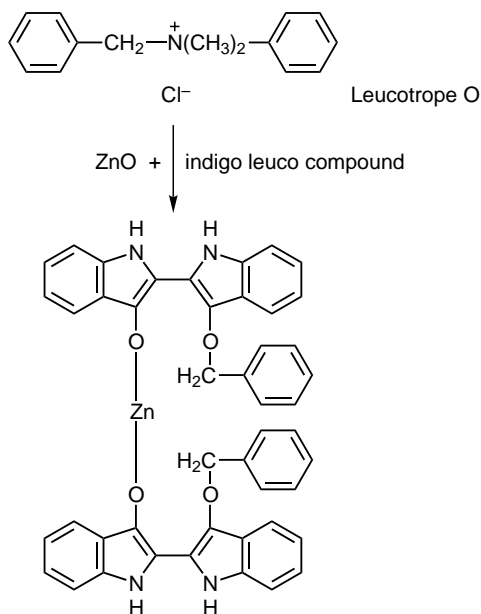

Scheme 6.2

technique can be chosen to produce a satisfactory discharge on whatever type of fabric is to be printed.

6.2.1 Print pastes for discharge printing

A typical print paste for discharge printing would contain dye (for a coloured discharge), discharging agent, other chemicals and auxiliaries, thickener and water. Each component requires detailed consideration.

Dye selection

The correct choice of dye is of fundamental importance in successful discharge printing, with respect to both the dischargeable ground and, where required, the illuminating, discharge-resistant dye. Fortunately, most modern dye ranges offer a reasonably adequate selection of both types.

Dyes which are suitable for the dischargeable ground usually contain azo groups that can be split by reduction. Even so, there are great differences in dischargeability between individual dyes. For example, many monoazo dyes in the disperse dye range, which are derivatives of azobenzene and have the general formula shown in structure 6.2, can be readily discharged. Their suitability as dyes for the production of discharge



grounds is, however, dependent on the substituents in the *ortho* position to the azo group, particularly in the R¹ and R² positions. The common substituents in the R³ position have less influence on dischargeability. A dye with a chlorine atom in the *ortho* position at R¹ or R² is more readily discharged than one with a bromine atom in the same position. For example, CI Disperse Orange 5 (6.3) on acetate fibres shows excellent dischargeability.

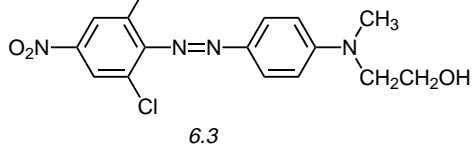
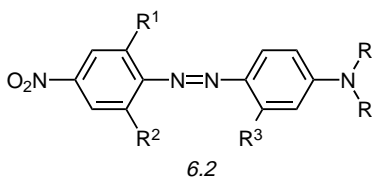

Dyes with two nitro groups and one chlorine atom, of the general structure 6.4, are more difficult to discharge than those with only one nitro and one chlorine substituent (6.5).

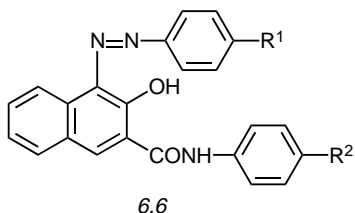
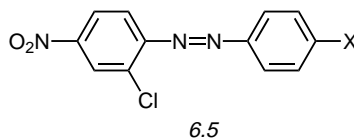
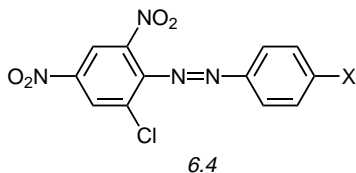

Dyes having the general structure 6.6 are difficult to discharge and can, in fact, be used as illuminating colours if some loss of tinctorial strength is accepted. In such structures the formation of internal hydrogen bonds would seem to produce a stabilising effect towards the discharge agent. Other examples of dischargeable dyes are CI Acid Yellow 17 (6.7) and CI Basic Blue 41 (6.8).

In addition to dischargeability, the colour of the amines produced by reductive cleavage is important. The ease with which the cleavage products can be removed from the discharge print during subsequent washing should also be taken into



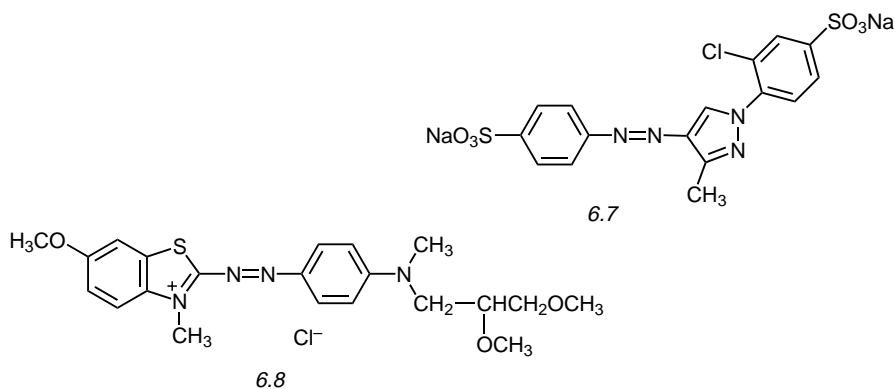

consideration. If they are not completely removed these residues will slowly darken, due to oxidation, and a white discharge that was initially satisfactory will become unacceptable. With a coloured discharge this point is less critical, as the illuminating colour will tend to mask any slight discoloration.

The great majority of discharge-resistant dyes are not azo dyes but are of the anthraquinonoid, phthalocyanine or triphenylmethane type. The choice depends upon the colour required, the reducing agent being used and the substrate.

The choice of dyes is facilitated by the dye manufacturers, who usually classify their products on a dischargeability scale ranging from 1 to 5. A dye which is classified as 5 or 4–5 on this scale would be suitable for a white discharge. For a coloured discharge, a dye classified as 4 would be acceptable or even 3–4 with very deep illuminating colours. Those dyes which have a dischargeability of only 1 are virtually undischageable and, therefore, are suitable as the illuminating colours in coloured discharge styles. Only a trial under actual working conditions can provide full and final information on the suitability of a dye for discharge printing.

Discharging agents

Clearly, the most important methods of discharging are based on reduction. This general method can be varied and adapted to give discharges with most classes of dye in use and on most types of fibre. Indeed, to many printers the terms ‘reducing agent’ and ‘discharging agent’ are synonymous.

The most widely used reducing agents are the formaldehyde sulphonylates. The stability of these compounds is such that only limited losses of sulphonylate occur during printing and prior to steaming. The use of sodium formaldehyde sulphonylate (CI Reducing Agent 2, sold as Formosul or Rongalite C) was established as long ago as 1905, when it was recognised that methods based on this reducing agent offered many



advantages. Other products are the insoluble zinc formaldehyde sulphonylate (CI Reducing Agent 4), water-soluble zinc formaldehyde sulphonylate (CI Reducing Agent 6) and the water-insoluble calcium formaldehyde sulphonylate (CI Reducing Agent 12).

A considerable amount of work has been carried out to show the manner in which the formaldehyde sulphonylates decompose when used for discharge printing and on the effect of different conditions on the resulting prints [2,3]. A much simplified explanation of the process is shown in Scheme 6.3.

Thiourea dioxide (CI Reducing Agent 11), sold as Manofast, has been used successfully in certain sectors. Although chemically inert to many reagents, an irreversible rearrangement takes place when it is heated with alkali and water with the formation of formamidine sulphinic acid. Decomposition then takes place, one of the products being sulphylic acid, and it is this which is the active reducing agent (Scheme 6.4). Another reducing agent, which has been used since the earliest times, is tin(II) chloride. It is a readily soluble compound which reacts with an azo dye as shown in Scheme 6.5. It is important that tin(II) chloride solutions are used quickly since hydrolysis, which gives a turbid solution, occurs on standing. The hydrochloric acid produced will attack unprotected metal. The steaming equipment is particularly

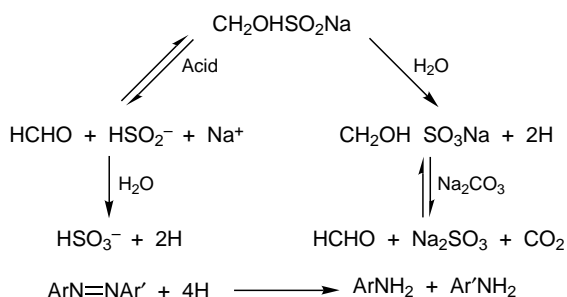

Scheme 6.3

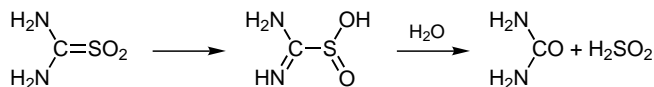

Scheme 6.4

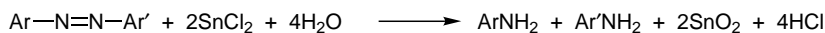

Scheme 6.5

vulnerable in this respect, and even the squeegee holders on printing machines may have to be protected with resistant lacquer.

The importance of tin(II) chloride diminished considerably on the introduction of the sulphoxylates, but it has now regained some significance in the discharge printing of synthetic fibres. It should be noted, however, that tin salts are undesirable in effluents.

The choice of reducing agent is determined largely by the fibre to be printed and, to some extent, by the dyes used. The soluble sulphoxylates can give haloing problems on the synthetic fibres, caused by capillary movement of solution along the yarns. This problem can be overcome by using the insoluble formaldehyde sulphoxylates or thiourea dioxide (CI Reducing Agent 11). This latter product has had a considerable success in the discharge printing of acetate and triacetate, due to its low tendency to haloing and also because it is effective under acid conditions, which do not saponify the fibres as an alkaline reducing system can do.

Printing pastes containing a high proportion of insoluble matter can, however, give rise to the difficulties of 'sticking in', scratching of copper rollers and blocking of screens unless finely ground powders with soft particles are used. In this respect, certain forms of calcium formaldehyde sulphoxylate are considered to be better than the insoluble zinc formaldehyde sulphoxylate, as they have a softer, 'talc-like' consistency as well as being more stable.

Generally, the sulphoxylates are stronger reducing agents than tin(II) chloride, and can be used to discharge a greater range of dyes. On the other hand, since very few dyes are absolutely resistant to reducing agents, tin(II) chloride is preferred with illuminating dyes. It would, therefore, seem logical to use both types of reducing agent for a pattern with white and coloured discharges, but most printers prefer to use only one reducing agent for simplicity of operation.

The actual amount of reducing agent required for optimum discharge will depend upon:

- the dyes to be discharged
- the depth of the ground
- the fabric being printed.

The use of insufficient reducing agent will, of course, give an incomplete discharge, whereas too much results in flushing or haloing during steaming, as well as being wasteful and uneconomic. Flushing of a white discharge results in blurred edges and a loss of fine detail, whilst in coloured discharges it is usually seen as a white halo around the printed areas. This is due to migration of the soluble reducing agent which, if the ground fabric has been dyed with a mixture of dyes with differing dischargeability, may produce a coloured halo. That is not to say that haloing and flushing must be avoided



at all costs, since some styles actually depend upon the various effects which can be achieved in this manner – the so-called ‘bleeder styles’ (section 6.5.2).

Other chemicals and auxiliaries

Anthraquinone is often used to improve the discharge effect of a reducing agent, and is therefore used on fabrics dyed with the azo dyes which are more difficult to discharge. During steaming it is reduced to hydroanthraquinone which, in turn, reduces the dye and is itself reconverted to anthraquinone. This cycle of reactions continues until reduction of the dye is complete. The anthraquinone might, therefore, be considered to be acting as a catalyst. The presence of anthraquinone improves the whites and renders them more stable in air by retarding any oxidation of fission products. It also promotes reproducibility in fluctuating steaming conditions but, to prevent subsequent discoloration, all anthraquinone must be removed in the washing process that follows.

Leucotropes are compounds of certain tertiary bases with benzyl chloride and its substitution products. Their use has already been mentioned in the context of the discharge printing of indigo; *Leucotrope W* can be used in other cases to improve the discharge effect.

It is often necessary to employ *penetrating agents* during steaming, especially with white discharges, to ensure that the discharge paste thoroughly penetrates the fabric and to prevent any ‘grinning’ or show-through effects, especially on knitted fabrics. Additives of this type include glycerol, ethylene glycols and thiodiglycol. They are effective mainly because of their humectant properties. The actual amounts used must be carefully determined under local conditions as too little would give a poor discharge effect, but too much could result in flushing and haloing. A penetrating agent is not always necessary with coloured discharges as the illuminating dye tends to mask any incomplete discharge. In fact, any auxiliary that improves penetration of the fibre can improve the discharge effect. Therefore, *carriers* and *fixation accelerators* are often added when printing illuminated discharges on synthetic fibres; in some cases, they improve a white discharge on such substrates.

Wetting agents are also necessary when printing on fabric of low absorbency which may be coated with dried film of thickener from the preliminary dyeing operation, as in the ‘discharge-resist’ process (section 6.3.6).

A wider range of illuminating colours can be used if they can be protected from the reducing agent; the anthraquinonoid pink and blue disperse dyes are particularly prone to attack if CI Reducing Agent 6 is used. Experience has shown that one of the best additives in this respect is *urea*, which adequately stabilises such dyes during steaming.

White discharges are usually improved by additions of *titanium dioxide* or other white pigment, and when thiourea dioxide is being used as the discharging agent the white is



improved by an addition of *zinc sulphate*. Discharge-resistant *fluorescent brighteners* are, of course, also very useful in improving white discharges, and are selected to suit the fibre being printed.

Thickeners

In discharge printing the correct choice of thickener is of even greater importance than in direct printing. Not only must all the requirements for direct printing be met, but the thickener must also have good stability to the reducing agent used, tin(II) chloride being particularly difficult. In this case, coagulation can occur if there is any incompatibility between the thickener and the tin(II) ions. Thus nonionic thickeners are necessary and anionic thickeners, such as the carboxymethylated types, should be avoided. The low pH (2–3) of tin(II) chloride solutions can also bring about hydrolysis of thickeners, with subsequent loss in viscosity. A low pH can also give rise to specky prints, due to aggregation or precipitation of certain dyes, notably some disperse dyes.

Specky prints can also be caused where particular dyes are absorbed by insoluble or acid-gelled materials in the thickener. Soluble dyes, such as basic dyes and acid dyes, can be precipitated by a high concentration of inorganic salt in the printing paste.

Since sharp and intricate patterns are characteristic of a discharge style, it is essential to minimise flushing and bleeding. It is, therefore, often necessary to use the low-viscosity thickeners and a high solids content. Thickeners that have been used include nonionic locust bean gum ethers, sodium carrageenates, starch ethers and crystal gums.

As already indicated, an essential criterion for successful discharge printing is the correct balance between penetration of the fabric and control of flushing and haloing. The control of penetration with humectants and the use of high-solids thickeners have already been mentioned. Other factors affecting the balance are:

- the viscosity of the discharge print paste
- the amount of print paste applied (controlled by factors such as mesh size, squeegee setting, engraving depth and so on)
- steaming conditions (discussed in Chapter 8).

6.2.2 Problems in discharge printing

There are certain practical problems associated with the actual printing of discharge styles. One of the most difficult is the location of the design on the fabric. This is because the print pastes are often almost colourless and, when applied to a dark ground, are virtually invisible, especially in roller printing with the machine running at speed. The incorporation of white pigment improves visibility; fugitive, contrasting



sighting colours help, as do fluorescent agents used with ultraviolet lights. This is perhaps an inevitable difficulty of the discharge style, and one reason why the resist approach may be preferred.

Controlled rapid drying of discharge prints is imperative if loss of reducing agent is to be minimised. This may mean wrapping the first drying cylinders to prevent boiling and, on the other hand, the use of hot-air blowers to accelerate drying on hand-screen tables.

Another problem encountered is that of 'facing' or 'scumming', which is due to partial discharge of the unprinted areas of the dyed ground. This occurs mainly in roller printing and arises if the thin film or 'scum' of discharge paste left on the unengraved surface of the printing roller is transferred to the fabric. In subsequent processing, the full bloom of the ground colour is lost. The reductive atmosphere existing in the steamer can similarly affect the dyed ground. These problems are avoided by meticulous attention to the basic printing techniques – factors such as careful maintenance of doctor blades and correctness of engravings – and by the application to the fabric before printing of a mild oxidising agent, such as sodium nitrobenzenesulphonate or sodium chlorate, which is preferentially reduced by the reducing agent and thus protects the dyed ground. Since such mild oxidising agents inhibit undesired reduction, some are referred to as 'resist salts', but should not be confused with resisting agents.

6.3 APPLICATION PROCEDURES IN DISCHARGE PRINTING

The application of these general principles to specific examples of discharge printing on various substrates can be illustrated through a selection of recipes and processing recommendations.

6.3.1 Vat discharges on cellulosic fibre

The coloured ground is applied using selected azoic, direct or reactive dyes, while the illuminating colours are selected vat dyes. When considered necessary, the dyed ground is prepped with 10 g l^{-1} 'resist salt' and dried, to prevent fading. After printing and drying the prints are steamed for 5–8 min at 102–104 °C in an air-free steamer. Washing and aftertreatment are carried out immediately, preferably in an open-width washing range, the first rinse being cold and the second hot.

When printing vat head-colour discharges, the first boxes of the washing range are used for oxidation of the vat dye. Initially the goods are washed in cold water with overflow and then oxidised at 40–50 °C with a suitable oxidising agent, such as



hydrogen peroxide. Hot soaping is then carried out with additions of suitable detergents and soda ash, if necessary. The formulations used are shown in Table 6.1.

Table 6.1 Formulations for stock pastes/g kg⁻¹

	1	2	3	4	5	6
Cl Reducing Agent 2	100–200	100–200	120	200	200	200
Glycerine	50					
Soda ash		50–100				
Caustic soda (38 °Bé)				50	175	200
Anthraquinone paste		20				
Leucotrope W conc.					80	
Cold water	200	140	280	150	120	20
Thickener ^a	600	600	500	500	400	400
Fluorescent brightener	5		5		5	5

- a Generally guar/starch ether blend; for whites and fine definition, blends of crystal gum with high-solids starch derivatives, such as Diatex SL (Diamalt), are sometimes required

Notes

- Formulations 1, 3, 5 and 6 are typical for white discharges. The Leucotrope W should not be used in coloured discharging as it can adversely affect the illuminating vat colour. It is also desirable to add a pigment white to the discharge paste to give the best possible contrast; for example, 80–100 g kg⁻¹ titanium dioxide is often used. When discharging direct dyes, formulation 1 can be used, whilst formulation 2 is typical for an azoic discharge. Formulations 3–6 are used for discharging reactive dyeings, vinyl sulphone dyes being especially important, as the bond with the fibre can be hydrolysed in the presence of caustic soda. The severity of the discharge increases from formulation 3 to formulation 6.
- To obtain a coloured discharge, it is normal to add vat dyes to the formulations indicated in the table (formulations 2 and 4). As can be observed, the formulae are very similar to those normally used for printing 'all-in' vats. In discharge printing, however, the reducing agent has to destroy the ground dye as well as to reduce the vat dye, so in some cases additional reducing agent may be required. Other adjustments from the standard formulation are made to prevent halo formation. The amount of glycerol, which is hygroscopic, may be cut down and it is normal to use soda ash, which is less hygroscopic than potash.
- With reactive dyes, the discharge can be achieved either by splitting the chromophore or by splitting the covalent link with the fibre. In the former case, which occurs under neutral or weakly acid conditions, discoloration of the white discharge can be instigated by reoxidation of the dye fission product, which is still linked with the fibre. Therefore, for permanent white discharges, it is advisable to use reactive dyes whose link with the fibre can be broken, thus leaving no linked residue. Vinyl sulphone reactive dyes are particularly suitable in this application as their ether linkage with the fibre can be broken by hydrolysis under strongly alkaline conditions. This is shown in Scheme 6.6.

With regenerated cellulose, it should be borne in mind that the alkalinity should be controlled so as not to affect the physical properties of the fibre.

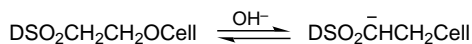

Scheme 6.6

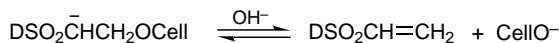

6.3.2 Pigment-illuminated discharges

These are applied to cellulosic substrates dyed with selected azoic, direct or reactive dyes, the illuminating colours being selected pigments. A sulphoxylate discharging agent is used (CI Reducing Agent 4 or 6). The fabric is dyed using conventional methods with dyes selected as being dischargeable.

Preparation of the dyed ground fabric is carried out by padding with a mild oxidising agent. This helps to prevent the formation of haloes around the printed areas. Mild oxidising agents based on sodium nitrobenzenesulphonate are commonly used at concentrations of between 5 and 30 g l⁻¹.

There are potentially two printing systems, one of which is based on an emulsion system with white spirit. Nowadays, however, for environmental reasons a spirit-free thickener system would normally be employed, based on a colloidal thickener or a synthetic thickener of high stability to electrolyte (Recipe 6.1).

Fixation and finishing of the prints

After printing and drying the fabric is steamed for 5–10 min in saturated steam to facilitate the discharge. Thermosoling for 5 min at 150 °C is carried out to fix the pigment head-colours. The prints are then rinsed cold and soaped at 50 °C with nonionic detergent, followed by a further rinse. Washing-off is necessary to ensure brilliant prints with optimum fastness, which do not contain discharge decomposition products.

6.3.3 Discharges on wool and silk

The coloured ground is applied using selected acid or reactive dyes, while the illuminating colours are selected basic, acid or (for silk only) disperse dyes (Recipe 6.2). The print pastes indicated are very general formulations and the actual compositions used are highly dependent upon local factory conditions.

Discharge printing of wool and silk is a very specialised form of printing, with substantial add-on value in terms of profitability being a key consideration. Due to the high fabric value, the principle of ‘right first time’ should apply. Probably the principal European markets for this form of printing are Italy and France; the only other significant world contender is Japan.

One of the limiting factors in this process is the small number of dyes which can be used as illuminating colours with good fastness due to the requirement that they must be stable in the presence of reducing agent [4]. The most popular reducing agent used is CI Reducing Agent 6, although the paste form of CI Reducing Agent 12 is also used.



Recipe 6.1*Emulsion system*

Stock paste	(per kg)	Print paste	(per kg)
CMC ^a thickener	75 g	Pigment	25–70 g
Emulsifying agent	10 g	Stock paste	x g
Water	115 g	Zinc formaldehyde sulphonylate	50 g
Urea	50 g	Diammonium phosphate (1:2)	25 g
Acrylic binder	100 g		
White spirit	650 g		

White-spirit-free system

Discharge paste	(per kg)
Pigment	27–70 g
Bean flour thickener (low solids, nonionic, acid- and electrolyte-resistant)	400–500 g
Acrylic binder	110–175 g
Glycerol	15 g
Defoamer	5 g
Zinc formaldehyde sulphonylate/bean flour thickener (1:1)	100 g
Diammonium phosphate (1:2)	25 g
Water or thickener	x g

a Carboxymethylcellulose

Notes

1. This process is used to produce crisp and brilliant coloured discharges on dyed grounds that are dischargeable under neutral or acid conditions. Not all pigments are suitable for this process and nondischargeable ones should be selected.
2. Pigment concentrations must not be too low (in general, not less than 10 g kg⁻¹), as the reducing effect of the reducing agent could have a detrimental effect on the shade. Shading of head-colours with low amounts of pigment should also be avoided for the same reason.
3. To optimise the pigment fastness, the amount of acrylic binder should be increased with increasing amounts of pigment used.

CI Reducing Agent 2 can be used in combination with zinc oxide, which behaves as a pigment white and a buffer [5].

After printing the fabric is dried as quickly as possible and steamed with minimum delay for 10–20 min at 100–120 °C. This is followed by a cold rinse, soaping at 50 °C, a warm rinse, and then finally a further cold rinse.



Recipe 6.2		
	White discharge	Coloured discharge
Thiodiglycol	40 g	40 g
Hot water	100 g	200 g
Thickener	500 g	500 g
Zinc formaldehyde sulphonylate (Cl Reducing Agent 6)	100–150 g	100–150 g
Titanium dioxide (1:1)	75 g	
Discharge-resistant dye		20–40 g
Sodium <i>m</i> -nitrobenzenesulphonate		5–20 g
	1000 g	1000 g

6.3.4 Discharges on secondary cellulose acetate

The coloured ground is applied using selected disperse dyes, while the illuminating colours are selected basic, vat or disperse dyes (Recipe 6.3).

The fabric is prepadded with resist salt (10 g l^{-1}) and dried, then printed, dried and steamed at atmospheric pressure for 20 min. It is rinsed well and then soaped at 50°C . For vat-colour discharges, after cold rinsing, the fabric is treated with hydrogen peroxide (35%; 5 ml l^{-1}) at 50°C to oxidise the vat dye, rinsed and dried.

6.3.5 Discharges on cellulose triacetate

The coloured ground is applied using selected disperse dyes, while the illuminating colours are selected vat, disperse or basic dyes (Recipe 6.4). Ground and illuminating dyes are fixed by high-temperature fixation; reduction clearing is the preferred aftertreatment. After printing and careful drying, the goods are steamed for either:

- 20–30 min at atmospheric pressure, or
- 20 min at 70 kPa (10 lbf in^{-2}) excess pressure, or
- 6–8 min at 170°C (high-temperature steam).

After steaming, a cold rinse is followed by soaping at 50°C and rinsing. If a vat head-colour is being printed then the leuco compound must, of course, be oxidised in the usual way.

6.3.6 Discharge and discharge-resist processes on polyester fibre

The coloured ground is applied using selected disperse dyes, while the illuminating



Recipe 6.3*White discharge*

Thiourea dioxide	100–200 g
Thickener (crystal gum, gum arabic, etc.)	500 g
Thiodiglycol	50 g
Water	100 g
	1000 g

A coloured discharge is obtained by adding disperse, basic or vat dyes to the above paste.

Notes

1. If very bright head-colours are required basic dyes can be used, but their fastness properties are limited on this fibre.
2. Nondischargeable disperse dyes are more often used than vat dyes for head-colours, to avoid the extra process of oxidation. The largest range of suitable disperse dyes stable to reducing agent is available when tin(II) chloride is used; as printers prefer not to use tin(II) chloride, however, a rather yellowish colour is often obtained. Thiourea dioxide is the most acceptable reducing agent. In practice formaldehyde is often added (50 g kg^{-1}) as more stable colours are thereby obtained.
3. Blends of diacetate and nylon can be discharged in the same way, but dyeings on nylon are more difficult to discharge than those on diacetate, and the efficiency of the discharge is reduced with increasing proportions of nylon in the blend.

Recipe 6.4

	White discharge	Coloured discharge
Thiourea dioxide	100–150 g	100–150 g
Thickener	500 g	500 g
Thiodiglycol	50 g	50 g
Water	100 g	100 g
Discharge-resistant dye		x g
Carrier		20 g
	1000 g	1000 g

Notes

1. Discharge of dyeings on triacetate is more difficult than on secondary acetate as the fibre is more hydrophobic and more highly crystalline. It is more difficult for the reducing agent to penetrate the fibre and destroy the dye, and subsequently the reduction products are difficult to remove. This accounts for the relatively severe conditions used at all stages of processing. Due to the problems encountered, a discharge-resist style is often preferred, as described overleaf for polyester substrates.
2. On triacetate/nylon blend fabrics the above recommendations apply, but with increasing amounts of nylon, satisfactory results are more difficult to obtain.



colours are selected discharge-resistant disperse dyes. The discharging agent can be either a reducing agent or an alkali.

Dyes that have diffused into polyester fibres in conventional dyeing are virtually impossible to discharge, because the hydrophobic properties of polyester make penetration of the reducing agent and removal of the reduced disperse dye extremely difficult. Results obtained are not acceptable commercially except for lightweight fabrics. Consequently the discharge-resist process was developed.

Polyester fabric is impregnated with dischargeable disperse dye, by pad mangle or lick roller, and dried at low temperature to keep the dye on the fibre surfaces. Discharge pastes containing CI Reducing Agent 6 or tin(II) chloride are printed on to the fabric and the dye is destroyed during drying and subsequent processing (Recipe 6.5). The safest approach is low-temperature (102 °C) steaming, which will not fix the ground colour, followed by a high-temperature fixation of ground and illuminating dyes.

An alternative method is to produce a discharge-resist effect using alkali on disperse dyes containing diester groups [6]. These groups hydrolyse in the presence of alkali to produce a water-soluble carboxylate salt (Scheme 6.7). The soluble sodium carboxylate form has no affinity for polyester. In practice, the diester disperse dye is padded on to the fabric, low-temperature dried and then overprinted with a print paste containing alkali. As with the process involving a reducing agent rather than alkali, the fixation is with high-temperature steaming followed by a reduction clear process.

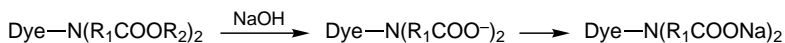

Scheme 6.7

A variation, apparently a resist method but in fact a discharge-resist technique using diester disperse dyes, was developed in 1980 [7]. This process uses the polymerisation properties of sodium silicate solutions of differing pH values. In the process, the coloured illuminant is locally polymerised when in contact wet-on-wet with the ground shade, which contains the disperse dye diester and a nonvolatile acid (Recipe 6.6) [8]. The sodium silicate in the illuminated head-colour is of a specific grade (ICI Mond Division grade 0100) to provide maximum effectiveness.

For the best definition, the fabric is dried as quickly as possible, and is fixed in high-temperature steam for 6–8 min at 165–175 °C. After cold-water rinsing a hot alkaline reduction is carried out, followed by rinsing in hot and cold water.

Discharge on dyed lightweight polyester

With the development of lightweight polyester fabrics, problems were encountered using the conventional discharge-resist styles concerning the printing of fine lines,



Recipe 6.5*Pad liquor for ground*

Disperse dye (dischargeable)	x g
Water at 20–30 °C	y g
Thickener (locust bean ether)	500–100 g
Wetting agent	2 g
Resist salt (1:2)	30 g
	1000 g

With reducing
agentWith
alkali*White discharge paste*

Locust bean ether thickener	500 g	500 g
Zinc formaldehyde sulfoxylate	80–150 g	
Caustic soda solution (38 °Be)		50–80 g
Discharge-stable FBA		5 g
Carrier	10 g	
Polyethylene glycol (r.m.m. 300–400)		50–80 g
Glycerol		5–80 g
	1000 g	1000 g

Illuminated discharge paste

Discharge-resistant disperse dye	x g	x g
Water at 40 °C	200 g	200 g
Locust bean ether thickener	500 g	500 g
Zinc formaldehyde sulfoxylate	60–120 g	
Polyethylene glycol (r.m.m. 400)		50 g
Urea	20 g	
Carrier	10 g	

Notes

1. Tin(II) chloride may be used as an alternative to CI Reducing Agent 6.
2. Formaldehyde (methanal) is incorporated to stabilise the reducing agent after printing, but before steaming.
3. Urea has been found to protect some discharge-resistant dyes, especially the anthraquinone pinks and blues, from attack by the reducing agent.
4. To prevent diffusion of dye into the fibre before discharge can occur, low-temperature steaming should precede fixation. Of the three alternative methods described below, the first two are to be preferred. The third is used when only a high-temperature steamer is available.
 - (a) Initially, to destroy the dischargeable dye, the fabric is steamed for 5 min at atmospheric pressure. The pressure is then raised to 140 kPa (21 lbf in⁻²) and steaming carried out for 20 min to fix the discharge-resistant illuminating colours and the coloured ground.
 - (b) Steam for 5–8 min at atmospheric pressure in saturated steam and then for 6–8 min at 175–180 °C in superheated steam.
 - (c) Discharge and fix in one high-temperature steaming operation for 6–7 min at 175–180 °C.



Recipe 6.6*Print illuminant*

Thickener	500–600 g
Glycerine	60–80 g
Polyethylene glycol (r.m.m. 300)	60–80 g
Sodium silicate	160 g
Alkali-stable FBA (white only)	5–15 g
Alkali-stable disperse dye	x g
Water	y g
	1000 g

Print ground

Sodium alginate thickener	350–500 g
Citric acid (to pH 4.5)	5 g
Diester disperse dye	x g
Water	y g
	1000 g

levelness and colour migration. As a result a new process was introduced based on the alkali-dischargeable diester disperse dyes and two auxiliary products, Zetex PN-AD (Zeneca) (a blend of ethoxylated products and polyols) and Zetex PN-DG (Zeneca) (based on an ethoxylated product) [8]. These products are said to provide a synergistic auxiliary combination which makes the new process possible. With the use of Wyoming bentonite in blends with conventional thickeners, fine lines can be obtained in the design. Thickeners containing sodium alginate are not recommended.

The lightweight fabric is dyed conventionally using recommended diester disperse dyes and after washing-off is stentered at low temperature to remove creases. Printing is carried out according to Recipe 6.7.

Recipe 6.7

	White	Coloured
Thickener	400–600 g	400–600 g
Matexil PN-AD (Zeneca)	120–200 g	120–180 g
Matexil PN-DG (Zeneca)	60–100 g	60–80 g
Sodium carbonate	60–80 g	60–80 g
Alkali-stable FBA	5–15 g	
Alkali-stable disperse dye		x g
	1000 g	1000 g



Fixation and simultaneous discharge of the ground shade is carried out by steaming for 6–8 min at 175–185 °C, followed by a washing process incorporating a reduction clear. This process is dependent on fabric dyeing and fabric construction, and it is essential to perform preliminary trials before beginning bulk production.

6.3.7 Discharges on nylon

The coloured ground is applied using selected acid, disperse, basic or direct dyes. The illuminating colours are selected acid, direct or basic dyes, and the discharging agent used is zinc formaldehyde sulphonylate (CI Reducing Agent 6) (Recipe 6.8).

After printing and drying, steaming is carried out for 10–30 min at 102 °C, and the prints are then rinsed and soaped at 50 °C.

Recipe 6.8

Dye	x g
Thiodiglycol	20–40 g
Hot water	200 g
Crystal gum solution (1:2)	500 g
Zinc formaldehyde sulphonylate (added after cooling)	100–200 g 1000 g

Notes

1. Basic dyes are often used for blue ground colours.
2. Disperse dyes have limited light and wet fastness properties.
3. An addition of zinc sulphate should be made for white discharges.

6.3.8 Discharges on acrylic fibres

The coloured ground is applied using selected dischargeable basic dyes, while the illuminating colours are nondischargeable basic dyes. The discharging agent may be a sulphonylate or tin(II) chloride (Recipe 6.9).

6.3.9 Discharges on polyester/cellulose blends

The direct printing of polyester/cotton blend fabrics with mixtures of disperse and reactive dyes presents problems (section 5.9.2) because of the low dye fixation levels obtained and problems of staining during the washing-off process. Discharge styles on



Recipe 6.9*White discharge*

Crystal gum (1:3)	200 g
British gum (1:1)	200 g
Water	200 g
Fixation accelerator (normally organic compounds containing nitro groups)	30 g
Sulphoxylate	100–200 g
Potassium thiocyanate	0–50 g
Fluorescent brightener (stable to discharge)	5 g
	1000 g

Colour discharge

Basic dye	x g
Water	200 g
Locust bean gum ether (10%)	400 g
Fixation accelerator (normally organic compounds containing nitro groups)	20 g
Tin(II) chloride (1:1)	100–180 g
Tartaric acid or citric acid	10 g
Potassium thiocyanate	0–50 g
	1000 g

After printing and drying, the fabric is steamed for 20 min at 20–40 kPa (3–6 lbf in⁻²) or 30 min at atmospheric pressure. After steaming, the prints are rinsed in cold water and then treated for 20 min at 40 °C with 1 ml l⁻¹ ammonia (25%) and 1 g l⁻¹ sodium hydrosulphite. This is followed by a further rinse at 40 °C and soaping in a fresh bath at 60–70 °C. Finally the prints are rinsed and dried.

Notes

1. Sulphoxylate is used only for the white discharge, as it is too powerful for the basic dyes employed as illuminating colours. Even with a white discharge careful control of the sulphoxylate must be exercised, otherwise haloing will result.
2. Excess fixation accelerator must not be used as this can also lead to halo formation; if pressure steaming is carried out the accelerator can be omitted. The potassium thiocyanate is a swelling agent for the acrylic fibre and has been found to give superior results, even in the presence of accelerator.
3. The washing-off procedure is critical for white discharges as the products of the discharge are not easily removed and oxidation in air can lead to tinting of the whites.

polyester/cotton have therefore been especially difficult. As in the case of 100% polyester substrates, a discharge-resist approach must be taken.

If pigments are used as illuminating colours, with a potential acid catalyst to crosslink the pigment binder, zinc formaldehyde sulphoxylate must be used as the



reducing agent. Experience shows that extreme care must be taken in washing-off to prevent unfixed disperse dye from staining the binder film.

If a mixture of vat and discharge-resistant disperse dyes is used, the problem is that the alkaline conditions required for fixing the vat dye illuminating colours produce large colour changes and low colour yields of the disperse dyes.

The availability of alkali-dischargeable disperse dyes has provided new possibilities. Used with selected vinyl sulphone reactive dyes, which are not fixed in the presence of sulphites, white discharges are possible. Coloured discharges can also be obtained by adding alkali-resistant disperse dyes and chlorotriazine-type reactive dyes that are fixed by alkali in the presence of sulphites. Alternatively, reactive dyes that are not fixed under alkaline conditions can be used for the dischargeable ground [9].

The polyester/cellulose fabrics have not found a commercially significant place in the discharge styles, cotton being technically much easier to discharge. Cotton is also perceived by the fashion industry to be preferable to polyester/cellulose blends.

6.4 RESIST PRINTING

Resist or reserve printing is related to discharge printing in that the end-results are often indistinguishable. The resist style, however, offers the advantage that dyes of great chemical stability, which could not be discharged, can be resisted to give prints of high fastness standards.

The justification for both styles lies in the aesthetic appeal of a white or coloured pattern on coloured grounds, an effect that very often could not be reproduced by any other technique. The difference, therefore, between discharge and resist printing is not one of appearance, but of process. In discharge printing, the discharging agent is applied to the fabric after it has been dyed and the dye in the printed areas is destroyed during subsequent processing. In resist printing, the resisting agent is printed on to the undyed fabric and effectively prevents the fixation or development of the ground colour, which is subsequently applied by an appropriate 'dyeing' technique, such as dyeing, padding or overprinting. The result can be either a white resist or a coloured resist, where a selected dye or pigment is added to the resist paste and becomes fixed to the fibre during subsequent processing.

Virtually every class of colorant is capable of being resisted, as is borne out by reference to older publications on textile printing [1]. Many of the techniques they describe are too complex and time-consuming to be of commercial interest today, but they do illustrate the wide scope of the style, with the proviso that it has little application to synthetic-fibre fabrics.

The resisting agents employed, then as now, function either mechanically or chemically or, sometimes, in both ways.



The mechanical resisting agents include waxes, fats, resins, thickeners and pigments, such as china clay, the oxides of zinc and titanium, and sulphates of lead and barium. Such mechanical resisting agents simply form a physical barrier between the fabric and the colorant. They are mainly used for the older, coarser and, perhaps, more decorative styles in which breadth of effect and variety of tone in the resisted areas are of more importance than sharp definition of the pattern. A classical, and nowadays almost unique, example of a purely mechanical resist is to be found in the batik style, using wax applied in the molten state. In a true batik the wax is applied by hand, but the process has been developed and mechanised for the production of those styles which now come under the general heading of 'Africa prints'. It is not possible to apply an illuminating colour with a wax resist but, after removal of the wax, another colour can be printed within the resisted area. These styles often fall outside the experience of most commercial printers and will be dealt with in more detail in section 6.5.1. A mechanical resist is usually used in conjunction with a chemical resist, so improving the overall effect.

Chemical-resisting agents include a wide variety of chemical compounds, such as acids, alkalis, various salts, and oxidising and reducing agents. They prevent fixation or development of the ground colour by chemically reacting with the dye or with the reagents necessary for its fixation or formation. The actual choice of chemical-resisting agent depends, therefore, on the chemistry of the dye being used and its fixation mechanism. Consequently, as in discharge printing, a working knowledge of the relevant chemistry is necessary when choosing effective resisting agents.

A classical example of the style, using indigo for the ground, illustrates a combined mechanical- and chemical-resist effect. A typical resist paste to give a white effect would contain china clay, a copper salt, a high-solids thickener (British gum or gum Senegal) and, possibly, tallow. Before printing, the fabric would be pretreated with starch and calendered, to give a flat surface upon which the resist print would form a more perfect protective cover. After printing, the goods would be thoroughly dried to consolidate the resist barrier. The ground would then be dyed by dipping the fabric into the indigo vat as many times as required to produce the desired depth of blue. The protective action of the resist paste would be partly due, in this case, to its oxidising properties, which would have the effect of throwing the indigo out of solution before it could reach the fibres. The insoluble deposit so formed would reinforce the mechanical-resist effect of the china clay, thickener and tallow. The process is completed by oxidation of the indigo and washing to remove thickener, surface dye and chemicals.

Resist print pastes that contain a high proportion of insoluble mechanical-resisting agents impose certain restrictions during the printing process. In copper-roller printing, such print pastes are apt to 'stick-in' in the engraving, especially in very fine patterns,



and to ensure good results a brush furnisher is indispensable in keeping the engraving clean. In screen printing it is important to ensure that the solid particles are not coarse enough to block the screen mesh. It is, therefore, customary in this case to strain the print paste through a sieve which has a finer mesh than that of the actual printing screen.

Not only must a resisting agent be able to prevent the fixation of the ground colour, but it must also be capable of surviving the actual dyeing process. It is therefore preferable to use materials that are not too readily soluble in water and to modify the dyeing process. Pad application of dye reduces the time of contact and therefore the bleeding of soluble resist agents.

Nip padding (Figure 6.1) is in fact usually preferred to immersion (slop) padding. Some thickening of the pad liquor may be necessary to increase the volume of liquor carried on to the fabric. The temperature of the dye solution must also be kept low, and it is often necessary to dry the fabric immediately after application of the dye. Use of an engraved cover roller, known as overprinting, provides an alternative to nip padding and one stage in the process may be eliminated if drying of the resist is not essential.

6.4.1 Resists under aniline black

Many of the points considered above are illustrated in the process of resist printing under aniline black. This particular colorant is formed on cellulosic materials by the

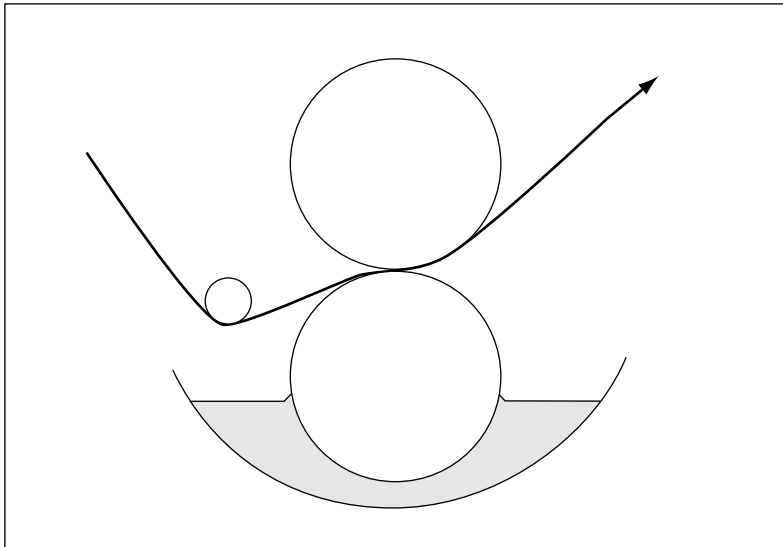

Figure 6.1 Nip padding mangle

oxidation of aniline; it is virtually indestructible and most certainly cannot be discharged. Unfortunately, some loss in fibre strength is incurred, due to oxidation of the cellulose. Nevertheless, the quality of the black so produced, its fastness properties and its low cost make it a highly desirable ground colorant for resist effects.

The first attempts in this direction were based on the fact that aniline black is an oxidation product; the earliest resists consisted of reducing agents. But it was later shown that the presence of mineral acid, either free or produced at a later stage during steaming by dissociation of an unstable salt, was equally essential in the development of the black. Alkaline salts and other neutralising agents can, therefore, be employed either alone or in combination with reducing agents, to prevent the formation of the aniline black in the printed areas.

A typical stock paste for resist printing of aniline black contains 125 g kg^{-1} sodium acetate, 125 g kg^{-1} zinc oxide paste (1:1), 10 g kg^{-1} sodium thiosulphate and a thickener based on low-viscosity alginate. This could be used to give a white resist; alternatively, a suitable dye could be added to produce a coloured resist. A typical aniline black liquor is prepared by mixing together the three solutions specified in Recipe 6.10 and bulking to 1 l. The actual process can then proceed in any of several different ways.

Recipe 6.10

1.	Aniline hydrochloride	80 g
	Aniline oil	5 g
	Tragacanth thickener (6%)	50 g
	Water	250 g
2.	Potassium ferrocyanide	50 g
	Water	200 g
3.	Sodium chlorate	30 g
	Water	200 g

Underprinting

The resist paste is printed on to the fabric and then overprinted with the black, which has been suitably thickened for printing. After drying the print is steamed to develop the black and oxidation is completed by an aftertreatment with hot acid dichromate solution. Such an aftertreatment also serves to reoxidise vat dyes used as illuminating colour.

Nip padding

The aniline black liquor is applied to preprinted and dried material by means of a roller



which runs in the thickened aniline black liquor and forms a nip with a second roller (Figure 6.1). A slop padding process is not recommended, as the soluble resisting agents tend to bleed and so cause haloing. Development of the black is carried out as indicated above.

Discharge-resist or afterprint process

In spite of its name this is nevertheless a resist process, but it is so called because the aniline black liquor is applied to the fabric before the resist paste. This is a technique requiring very close control, but it is usually preferred for high-class work because when employed correctly it yields sharper and brighter colour effects than can be obtained from the preprint processes.

The importance of careful control over every stage of the process cannot be overemphasised. The aniline black liquors must be freshly prepared and, as in the discharge-resist style on polyester, drying of the padded material must be carried out with great care. On emerging from the drying machine, the goods ought to be light yellow without a trace of green. If they have been so far overdried as to become greenish they are unsuitable for light-coloured and white resists because the green is undischageable.

After drying, the padded goods should be cooled to prevent oxidation and printed as soon as possible. After printing, overdrying must again be avoided and steaming, to develop the black, should be carried out without delay. The steam should not be too moist, as otherwise the colours are apt to run and the whites can become discoloured. The whole process from start to finish must be carried out without undue delays and with careful control at every stage.

As already indicated, coloured resists under aniline black can be obtained with vat dyes where the inherent alkaline and reducing nature of an 'all-in' print paste provide the desired resist effect.

Reactive dyes can also be used by fixing the print by one of the various two-phase processes after the black been developed. Pigments may be used to illuminate the resist, in which case a suitable quantity of pigment binder would be added to the print paste, together with zinc oxide, magnesium carbonate and sodium acetate. Such print pastes can be used to give both preprint and afterprint resists.

6.4.2 Resists under reactive dyes

Due to the wide range of available colours, brightness and good all-round fastness properties, reactive dyes are now very popular both for direct printing and for plain dyeings. Discharge printing can be carried out successfully on selected reactive



grounds, particularly those produced with dyes of the vinyl sulphone type. There are difficulties with blue and turquoise dyes which are not azo compounds, however, and this makes the use of resist processes necessary.

Most reactive dyes can only be fixed on cellulosic fibres in the presence of alkali. Consequently nonvolatile organic acids (such as tartaric or citric acid) and acid salts (such as monosodium phosphate) may be used as resist agents for preprint resists under such dyes. Hence, the thickeners used should be acid-resistant. Hydroxyethylated and methylhydroxyethylated cellulose ethers, locust bean gum and tragacanth are suitable for this purpose. When printing with deeply engraved rollers the concentration of acid- or alkali-binding substance can be kept low, but an increase in the concentration may be required if sharp effects are to be obtained with shallow engravings. A typical preprint resist paste would have the composition shown in Recipe 6.11. The colourless resist print pastes may be made visible by tinting with a fugitive dye such as CI Acid Blue 1, or by adding a fluorescent brightener, which is detected with the help of a ultraviolet lamp.

Recipe 6.11

Citric acid	50 g
Thickener	600 g
Water to	1000 g

After the material has been printed and dried it is nip-padded, overprinted or padded with a solution of a high-reactivity reactive dye containing a minimum concentration of sodium bicarbonate. If the material is to be immersed in the dye liquor, it may be necessary to increase the acid concentration in the print paste to 80 g kg⁻¹. Long immersion times should be avoided for reasons already mentioned. Drying must follow immediately, then an appropriate fixation step, and washing.

A typical padding liquor is shown in Recipe 6.12. Certain alkali donors may be

Recipe 6.12

Reactive dye	20 g
Resist salt	7 g
Hot water	393 g
cooled to 40 °C and diluted with	
Cold sodium bicarbonate solution (3%)	500 g
Thickener	80 g
Water to	1000 g



employed instead of sodium bicarbonate, in which case the steaming time should be increased to 7–10 min to allow for adequate breakdown of such compounds and subsequent fixation of the dye.

An alternative preprint method for white resists, using a two-phase fixation process, can be carried out as follows:

1. Print the white material with acid-resist paste, and dry
2. Pad with a neutral dye liquor, and dry
3. Nip-pad the material with fixation liquor, fix, wash-off and dry.

The fixation liquor used for this method would be as shown in Recipe 6.13, and fixation is best carried out by steaming for 20 s.

An overprinting technique can also be employed to give white resists on a reactive pad dyeing. The material is first padded, using Recipe 6.14. After drying, the padded material is printed with an acid-resist print paste (Recipe 6.15). After printing, the material is dried carefully to avoid fibre damage. Fixation of the ground is carried out by any convenient two-phase process which would involve the application of an alkaline fixing liquid followed by steaming, or cold dwell, and the usual final wash-off and drying.

Very effective results can be achieved with a white pre-resist under overprints with reactive dyes. This can be done either with intermediate drying or by printing wet-on-

Recipe 6.13

Caustic soda (38 °Bé)	20 ml
Sodium sulphate (anhydrous)	200 g
Common salt	100 g
Water to	1000 ml

Recipe 6.14

Reactive dye	1–40 g
Water at 80–90 °C	300 g
Neutral thickener	50 g
Resist salt (1:2)	15 g
Lactic acid (50%) ^a	2 g
Water to	1000 ml

a Or 1 g tartaric or citric acid

Recipe 6.15

Citric acid (1:1)	200 g
Acid-resistant thickener	400 g
Water	400 g
	1000 g



wet. The acidic resist paste is made up as previously described and the overprint is based on a standard direct-printing recipe containing alkali. After the second printing, the goods are dried, then steamed to bring about fixation of the overprinted dye, and washed off as usual. A solids-rich thickener gives sharp outlines and should be used, particularly if the overprints are to be produced by printing wet-on-wet. In screen printing some of the acid-resist paste will be transferred from the fabric on to the underside of the following overprint screen. There it acts upon the acid-sensitive alginate thickener, precipitating it in the mesh of the screen as alginic acid. The screen, therefore, becomes blocked in these areas and actually assists the production of the desired effect. In roller printing, however, care should be taken to prevent the acidic print paste from being carried forward to contaminate the overprint paste, which would cause precipitated thickener to stick in the engraving. If necessary, one or more plain rollers can be inserted between the resist roller and the overprint roller as a precautionary measure.

Coloured resists under reactive dyes can be produced in several ways [10]. One of the most popular is to preprint the fabric with a pigment print paste containing an addition of acid to act as resist agent. The pigment binder should preferably be one that can be fixed by steaming. A typical stock paste will be made up as shown in Recipe 6.16. The actual print paste would be prepared from this stock paste by adding the requisite quantity of pigment. The sequence of operations would then be as follows:

1. Preprint with pigment paste containing acid
2. Pad with reactive dye, after intermediate drying, or overprint without drying
3. Steam for 2–10 min according to the reactivity of the dye used
4. Wash-off
5. Dry.

Recipe 6.16 uses an emulsion thickening system, but due to environmental legislation, restrictions as to the use of systems based on white spirit resulted in the promotion of

Recipe 6.16

Thickener (cellulose ether)	100 g
Emulsifier	8 g
Water	100 g
Pigment binder	120 g
White spirit	612 g
Tartaric acid (1:1)	60 g
	1000 g



further developments using aqueous systems based on synthetic thickeners [11]. Prior to this, the synthetic thickeners used to prepare aqueous pigment thickeners were unacceptable as the acid required for the resist produced an unacceptable drop in viscosity.

Resists with Fast Colour Salts under reactive dyes can also be carried out, and give interesting results that exploit the economy and colour range of both classes of dye. When naphtholated fabrics are printed with Fast Colour Salts, alongside reactive dyes of the vinyl sulphone type, the reactive dye can be fixed by raising the alkalinity of the prepared fabric and by brief steaming after printing. The reactive print may be resisted to a greater or lesser extent by the acid in the Fast Colour Salt print in the areas where the two print colours meet or overlap. In many cases, the Fast Colour Salts contain so much alkali binder that the reactive dyes can be resisted completely. If not, the desired resist effect may be obtained by the addition of acid or acid salts. Naturally, the amount of acid or acid salt added must not be so high that the pH for the azoic coupling is significantly lower than the optimum value.

Half-tone effects under reactive dyes can be produced by mechanical and chemical methods. Such resists are obtained by, for instance, merely preprinting the material with a solids-rich thickener, which coagulates under the influence of the alkali in the reactive overprint. The resist effect can be emphasised by adding titanium dioxide or other white pigment to the resist paste. The reactive colour pastes which are to be partially resisted can be printed, wet-on-wet, on top of the resists and, after drying, the dye is fixed by a suitable two-phase process. If the reactive coloured ground is applied by a pad–steam process, then intermediate drying is necessary before the padding.

All-reactive resists

The wide colour range available makes the idea of the ‘reactive resist under reactive ground’ style particularly attractive, provided it can be achieved in a reliable manner [12]. One approach depends upon the fact that the fixation of vinyl sulphone-type reactive dyes can be prevented by the addition of sulphites, thiosulphates or thiourea [13,14]. The fixation of selected reactive dyes of the substitution reaction type is not affected by additions of these agents and they can therefore be used as illuminating head-colours. White- and coloured-resist pastes can be prepared by making 150 g kg⁻¹ additions of the resist shown in Recipe 6.17 to standard stock pastes. The printed fabric can be overprinted, wet-on-wet, with a standard vinyl sulphone print paste. Drying is carried out below 120 °C and fixation brought about in saturated steam. The process is completed by the usual thorough washing. This process and other variants of the ‘reactive under reactive resist’ styles are summarised in Table 6.2.

Variant 1 is suitable for rotary-screen and roller printing but is not recommended for



Recipe 6.17

Sodium bisulphite (38 °Bé)	310 g
Sodium bicarbonate	500 g
Glyoxal (40%)	65 g
Water	125 g

Table 6.2 'Reactive under reactive resist' styles

Overprinting wet on wet (variant 1)	Fixation of ground in one-step process (variant 2)	Fixation of ground in two-step process (variant 3)
Preprint white and coloured resists	Pad the ground with vinyl sulphone dyes and Remazol salt FD (sodium organic acid) (HOE)	Pad the ground with vinyl sulphone dyes (slightly acid liquor)
Overprint the ground wet-on-wet with vinyl sulphone dyes containing bicarbonate	Dry at 80 °C	Dry
Dry below 120 °C	Overprint the white and coloured resists	Overprint the white and coloured resists
Steam 6–8 minutes with saturated steam	Dry below 120 °C	Dry below 120 °C
Wash-off	Steam 6–8 min with saturated steam	Steam 6–8 min with saturated steam
	Wash-off	Fix ground by two-phase process
		Wash-off

Mixtures of vinyl sulphone and resist-stable reactive dyes

Variant 4A

Print mixtures of vinyl sulphone and resist-stable reactive dyes
Overprint white or coloured resists wet-on-wet
Dry below 120 °C
Steam 6–8 min with saturated steam at 120 °C
Wash-off

Variant 4B

Pad mixtures of vinyl sulphone and resist-stable reactive dyes
Overprint monochlorotriazine dyes and/or
Overprint vinyl sulphone dyes and/or overprint mixtures of vinyl sulphone and monochlorotriazine dyes
Overprint white resists
Steam 6–8 min with saturated steam at 120 °C
Wash-off



flat-screen printing because of problems related to this process, such as the pressing of the screen frame on the preprinted ground colours. The process does not give exactly the same effect as would be obtained if the ground was dyed, due to the difference in penetration.

Variation 2 produces the full dyed ground effect lacking in variation 1. Certain conditions must be maintained. In particular, the drying of the dyed ground must be carried out below 80 °C, as at higher temperatures the Remazol Salt FD would decompose and alkali would then partly fix the vinyl sulphone ground; a high-quality resist would then not be possible. Also the padded, unfixed fabric should not be stored for more than 24 h.

Variation 3 does not require the dyeing temperature to be limited because of slightly acidic conditions, and the fabric can be stored for longer periods. Two-phase steaming or two-phase cold-dwell processes can be employed, although there is a higher risk of mark-off during the cold-dwell process.

Variations 4 (A and B) are interesting for producing half-tone effects. Attractive multicoloured effects can also be obtained by mixing vinyl sulphone and monochlorotriazine dyes of different shades; for example, a vinyl sulphone yellow and a monochlorotriazine turquoise produce a green. On partially overprinting this combination with resist paste, a turquoise colour results.

An earlier approach made use of the very large difference between the rates of reaction of the dichloro- and monochloro-triazine dyes. Printing a dichlorotriazine dye with an addition of a colourless dichlorotriazine, but without alkali, followed by overprinting with a monochlorotriazine dye with minimum alkali, drying, steaming and washing can give effective coloured resists. In practice this approach was difficult and was not widely adopted.

When acid-fixing reactive dyes were used for the dyed ground, and were not fixed before printing, there was the attractively simple possibility of printing alkali only for a white discharge resist. The more stable alkali-fixing reactive dyes could be used for illuminating colours. This approach is not at present possible, however, as the dyes are no longer commercially available [9].

6.4.3 Vat resists under vat-dyed grounds

This is certainly not a widely used style, but it has been, and could be, used where the fastness properties associated with vat dyes are necessary. The material is first printed with a normal all-in vat print paste with addition of sodium thiosulphate. After steaming, to reduce the vat dye, the material is padded in a solution containing a vat leuco ester and sodium nitrite, followed by passage through a sulphuric acid solution. The alkali in the vat print neutralises the acid and the sodium thiosulphate is



preferentially oxidised, preventing development in the printed areas. The goods are finally aftertreated in the normal manner prescribed for vats.

6.4.4 Resists under azoic colorants

A traditional style of clean whites and bright reds under navy blue (Variamine) grounds is economically produced entirely with azoic colorants.

The Variamine Blue salts couple with Naphtol AS (CI Coupling Component 2) less readily than all other diazo salts, and the reaction occurs at an acceptable rate only in the optimum pH range of 7–8 [15]. Thus it is not difficult to effect a resist by reducing the pH. A paste containing 50–100 g kg⁻¹ of aluminium sulphate is printed on to naphtholated cotton, which is then dried and padded with Variamine Blue salt solution and allowed about 40 s air passage (or a short steaming) for coupling to take place; this produces a white resist on a navy ground. The aluminium sulphate reduces the pH to about 4, converting the naphtholate to the free Naphtol AS, which does not couple, and precipitating aluminium hydroxide, which acts as a physical resist. Naphtol AS is readily removed in the normal afterwashing, which is best preceded by a hot sulphite bath to destroy excess Variamine salt.

Any fast-coupling diazo salt could be printed, in excess, on to naphtholated fabric to give a coloured resist under the Variamine navy ground, because very little Naphtol AS would remain unreacted. Clean bright resists are only obtained, however, if no trace of blue is produced. By choosing one of the orange or red salts that couple most easily at pH 4–5 (CI Diazo Components 2, 6–9, 11, 34, 36 and 37), the required pH and resist effect can be obtained by adding aluminium sulphate. For example, the print paste shown in Recipe 6.18 might be used. Additional colours can be obtained with pigments or with solubilised vats, if an intermediate steaming is acceptable. In the latter case bisulphite can be used to resist the diazo coupling, and lead chromate to provide the oxidation in subsequent acid treatment.

Recipe 6.18

Fast Red Salt 3GL	80 g
(CI Azoic Diazo Component 9)	
Starch tragacanth thickener ^a	500 g
Aluminium sulphate (1:1)	100 g
Water	320 g
	1000 g

a Or hydroxyethylcellulose



It is not possible to produce resists under red azoics simply by pH control, but the use of phenylhydrazine *p*-sulphonic acid (Resist H, HOE) does give this possibility. The compound is printed on naphtholated fabric which is then overprinted, or dried and nip-padded, with one of a range of orange to bordeaux salts. Resist H reacts with the diazonium salt so rapidly that no coupling occurs and clean whites are obtained. Coloured resists are obtained by adding selected reactive dyes to the resist paste. Vinyl sulphone dyes are particularly suitable and should be used with sodium dihydrogenphosphate as a buffer. After printing and application of the Fast Colour Salt, it is recommended that fixation of the reactive dyes is achieved by the hot wet-fixation method. This provides an ideal start to the removal of unreacted coupling components in the subsequent open-width washing. Print pastes for these resists can be based on a stock paste prepared as shown in Recipe 6.19.

Recipe 6.19

Stock paste

Resist H	200 g
Sodium hydroxide solution (37 °Bé)	100 g
Tylose H300 (powder)	30 g
Water at 70–80 °C	500 g
Tartaric acid (dissolved in 145 g water), added after cooling	25 g

Print paste

Stock paste	400 g
Sodium dihydrogenphosphate	50 g
Tylose H300 (6% paste)	300 g
Reactive dye	0–80 g
Water to	1000 g

A specific example will illustrate the interesting possibilities this style presents. A fabric prepared with Naphtol AS is printed with a resist paste containing a Remazol yellow, then all-over printed (wet-on-wet) with a mixture of Fast Red Salt TR (CI Azoic Diazo Component 11) and Remazol Turquoise (Reactive Blue 21). In the yellow print areas the Resist H prevents formation of any red, and a bright green is produced. In the surrounding areas the red and turquoise produce an attractive brown colour. One printing run, drying and a wet-fixation process, therefore, gives a green resist under a brown ground, without the dark overlapping areas or white places that would be obtained by direct printing (unless the pattern fitting accuracy was perfect). Fees has discussed the general use of such economical and attractive styles [16].



6.4.5 Resist printing of wool

Over the years, various methods for resist printing wool have been investigated. Bell has reviewed some of these [4], of which two are of interest.

In practical terms, the chemical resist product Sandospense R (S) is a reactive resist agent similar to a reactive dye, which is itself colourless. Bell and Lewis describe the reaction in which the resist agent reacts with the amino groups in the wool, blocking the reactive sites [17]. The resist also is complemented by anionic repulsion. In this process pale shades can be resisted to white, and varying effects are obtained with greater depth of shade.

Secondly, sulphamic acid used as a nonionic dye resist agent for wool was patented by Sandoz in 1955 [18]. Little progress was made until Bell *et al.* determined that the resist was effective against reactive dyes [19]. Sulphamic acid is used at a concentration of 150–200 g kg⁻¹ together with similar quantities of urea in the print paste, which also incorporated thickener, nonionic wetting agent and antifoam. To prepare an illuminated colour, certain reactive dyes (covalent fixing) are added to the paste. After printing, thermofixing for 4–5 min at 150–160 °C is carried out to fix the sulphamic acid. Steaming follows for 30 min at 100–120 °C for fixation of the reactive illuminating colour. Full washing-off is carried out, including an ammonia wash at 70 °C for complete removal of unfixed dye, thus preventing subsequent cross-staining of unprinted areas during the final dyeing. This dyeing is carried out with selected reactive dyes from various ranges.

6.5 SPECIAL STYLES

This section is devoted to a selection of those printing styles which, although not now produced by the majority of commercial printing establishments, still have some interest and significance for specialised outlets. Some knowledge of the special techniques employed in the production of such styles leads to a deeper understanding and appreciation of the art of textile printing and stimulates the constant search for new effects.

Several related styles, still of considerable commercial importance, fall under the general heading of 'Africa prints'.

6.5.1 Africa prints

The modern Africa print style is based on a popular selection made by African people from a large number of widely different textiles exported to that continent. Hence 'Africa prints' has become a collective term for various types of printed article which were, at some time, adopted by the African population for their tribal costumes. It is



hardly possible to discuss Africa prints without some reference to their historical and geographical origins.

Some of the oldest Africa print styles have their origin in the tie-dyeing or Bandhana technique, which is a simple mechanical-resist process. How long this technique has been practised and how it came to Africa is outside the scope of this book, but the characteristics and designs produced by this method still have an influence on later African printing.

Another type of resist print is obtained by a mechanical resist, usually wax, to cover those areas of the fabric that are to be patterned, and then dyeing the fabric. This is known as the batik style and the wax is, of course, a true mechanical resist. Indonesia is generally regarded as the country of origin, but the Chinese too are thought to have used this method. In Egypt, wax resist prints were reputedly known as early as 1500 BC, and in South America relics of such prints were found to date back to the old Peruvian civilisation.

Which country is the true cradle of the wax printing method is still disputed, but the influence of the art of batik printing on the Africa print style is unquestioned, and the exquisite beauty of the prints that were produced by this method in different parts of the world has always been acknowledged. Today the Indonesian batiks are, perhaps, the most widely known and their influence can be traced in some of the patterned motifs encountered in Africa prints, motifs which are known to be South East Asian in tradition.

The Africans would appear to share with the South East Asians a gift for expressing their feelings in pictures and symbols and also a similar sense of colour. These are probably some of the reasons why such styles were readily accepted on the African continent when brought there by the Dutch and Portuguese traders from their South East Asian colonies. Although Indonesian in origin, many of the motifs found in these styles are now peculiar to the African continent, and it has become a truly African style. Nevertheless, traditional Indonesian batiks are still produced and a brief description of the processes involved forms a useful background against which the more up-to-date methods may be discussed.

An Indonesian printer may require as many as seven to eight days to produce a batik of a size sufficient for a sarong. The fabric is first scoured and kneaded with peanut oil or another vegetable oil to make it receptive to the print which should penetrate and adhere well. This treatment is also indispensable for the subsequent dyeing process, since it ensures satisfactory penetration and adsorption of the dye by the fibre. The oil was formerly removed by treating the cloth in a suspension of rice straw ash in water, but this process is now carried out with soda ash and has to be repeated several times.

The batik printer, usually a woman, sits cross-legged in front of the length of cloth, which hangs from a wooden or bamboo stand known as a Gawangan. The molten wax



is applied to the fabric by means of Tjantings, that is, small vessels of calabash gourd or metal pierced by openings of various sizes, often fitted with small spouts. The worker pours the melted wax over those portions of the fabric which are required to remain uncoloured. Often the outlines of the pattern are first roughly sketched on the fabric before being drawn in wax, but experienced batik printers know their patterns by heart and draw them freehand. When one side is finished the fabric is held against the light and the pattern is drawn in wax on the reverse. The fabric is now ready for dyeing, the first colour generally being indigo. The dye recipes are traditional within families and many contain very peculiar ingredients, such as brown palm sugar, fermented cassava starch, various types of banana and even ground chicken meat.

After dyeing the wax must be removed from the fabric and this is done by mechanical treatment and by treating in boiling water. Sometimes alkali is added so as to form an easily removable emulsion. The whole sequence of wax application and dyeing operations is repeated as many times as are necessitated by the design of the article. A characteristic feature of a batik print is the appearance of fine veins of colour running irregularly across the reserved parts of the pattern. This is due to penetration of the dye liquor through cracks which have formed in the coating of wax.

Obviously, such a process could not cater for the many millions of metres of material that are required to be printed annually to African styles. Consequently, methods have been evolved to imitate the traditional batik styles by more up-to-date production methods.

Africa prints can be divided according to production techniques into the following groups:

- real wax prints
- Java prints
- green-ground prints
- imitation wax prints
- fancy prints.

Real wax prints

The prints found in this group are so called because the design is, indeed, produced by covering the patterned areas of the fabric with a wax resist and subsequently dyeing the areas left free. The resisting agent used is usually a rosin obtained from certain pine trees and, like wax, it must be applied in the molten state.

Special duplex machinery has been developed which prints both sides of the material. The printing is by engraved copper rollers which, together with the containers and other components associated with the rosin, are heated to keep it in the molten state. Immediately after printing, the fabric is quenched in cold water so that the rosin solidifies and the sharpness of detail is maintained.



The fact that the printer cannot dry the fabric in the normal way brings its own special problems during the subsequent dyeing processes. Moreover, since the dye most often applied is indigo, special precautions have to be taken when preparing the dyebath, to avoid removal of the rosin at the normal alkalinity. Consequently, the indigo is usually vatted with a zinc and lime recipe and dyed at room temperature. The characteristic marbling effect produced by fine lines in the resisted areas is ensured by deliberate cracking of the rosin print, either by passing through a pot-eye or by 'tumbling' the material in cold water, before the continuous dyeing stage.

After dyeing, but before going on to subsequent resisting and printing operations, the wax is partially or completely removed from the fabric by hot washing, depending upon the type of effect required. When removal is partial, spots of rosin are left on the fabric and resist the later colours. Such resist spots do not repeat exactly with the basic design, and this is considered to be a typical and valuable feature. Azoic colours are often used, both base printing and naphthol printing being practised. Reactive dyes are also used, printed as neutral pastes with subsequent wet fixation in hot alkaline liquors. The second, third and any other colours are almost exclusively printed by means of blocks or screens, with the colours fitted by hand into the original pattern because of the dimensional changes caused by washing and drying.

Mordant dyes usually accompanied indigo in classical real wax printing, but nowadays azoic colorants are widely used; they offer the same coloristic possibilities and are technically superior.

The characteristics of real wax prints can be summarised as follows. The basic pattern is dyed with indigo (tested by sublimation); the fabric displays a characteristic unprinted strip about 1 cm wide along each selvedge and an irregular marble or veined appearance (caused by the cracks in the wax resist coat) which does not occur in the normal pattern repeat. The indigo print shows the characteristic pale blue half-shadow on one side of the motif, which is reversed on the other side of the print (this arises because the original duplex wax print is never in exact register). As the dye penetration is good, it looks virtually the same on both sides. The handle is very soft, heavy and sticky; occasionally, the fabric has a lingering smell of rosin.

Real wax prints are inevitably very expensive, because of the number of separate processes. Attempts to imitate the style have therefore been frequently made. The real wax print is, of course, itself an imitation of the old batik prints, but of all the imitations, this is the one that comes nearest to the original article.

Java prints

The description 'Java print' is nowadays applied to a specific type of article which may have only a tenuous connection with Java. Typical of this type of print is a colour



scheme consisting of brilliant dark green, lemon yellow, chocolate brown and golden yellow, although this can be varied to include, for example, pale blue or ruby red. Formerly, the design consisted of Javanese motifs, but today the term is essentially an indication of the colour scheme and the motifs are of only secondary interest. With a little expertise and knowledge almost any design can thus be made into a Java print.

The modern Java print has developed into a blotch print with one or two colours over a delicate filigree pattern. Originally, the filigree pattern was drawn in wax with the Tjanting, and the blotch print effect was obtained by dyeing the fabric with indigo or other natural dyes. In the modern Java print, the effect can be obtained by the use of a resist agent (Rapidamine Resist D, HOE), which is printed on to a Naphtol AS-G prepared fabric before overprinting with Rapidamine Blue G (CI Ingrain Blue 5) and other Fast Colour Salts.

The coloured resists are obtained by adding selected vinyl sulphone reactive dyes to the resist paste.

The Java print is a particular favourite in Africa and may be encountered throughout the entire continent, whereas other styles tend to be adopted individually by small populations or tribal units. Because of its general popularity, the Java print can be considered as a 'pan-African' style.

Green-ground prints

The green-ground print strongly resembles the Java print and is also essentially characterised by its colour scheme.

This article, which at one time played an important role in the African market, is produced by an elegant resist printing technique and is, coloristically, indeed a work of art. The Java print is generally considered to be the more beautiful of the two styles, however, and the green-ground print has now fallen into decline.

Imitation wax prints

The aim here is to imitate real wax prints without the lengthy wax resist printing procedure. Considerable ingenuity has been exercised to imitate the veining effects and other features of a real wax print by the use of engraved rollers and other modifications of a conventional printing process. These include duplex printing so that the veining effect appears on both sides of the fabric.

Another method is to print the veined effect on to the back-grey before it meets the actual fabric to be printed, so that marking-off occurs to give the desired effect on the reverse of the fabric. Another possibility is to print the veins in a second printing operation using a longer repeat.



Another characteristic of a real wax print that can be imitated is the half-shadow of indigo resulting from failure to fit the resist on the reverse face of the fabric. A carefully engraved additional roller is used to print the pale blue shadow on one edge of the motifs. This half-shadow effect is not due to bleeding of the indigo and must not be confused with the specific 'bleeder' style, described in section 6.5.2.

Fancy prints

The 'fancy print' style may, perhaps, be described as an Africa print whose pattern is composed of a motif that is particularly popular or contains a dominant colour that is currently much in demand. At first sight these prints have some, although very superficial, resemblance to true Africa prints, but generally they are produced with complete disregard of the characteristics of traditional Africa prints.

Any topical event, public occasion, inauguration, any political happening of nationwide importance, any new minister or president of state, or his birthday, may be regarded as important enough to be commemorated by the creation of a special fashion article incorporating a popular motif. These prints often display none of the characteristic features of wax prints.

6.5.2 Bleeder styles

This style, characterised by coloured haloes deliberately produced around the pattern, has recently been revived, following the introduction of several simple and economical techniques.

One technique uses mixtures of selected reactive dyes and Fast Colour Salts printed on fabric prepared with Naphtol AS. A thickener is chosen which coagulates on contact with the alkali in the prepared fabric, so that it releases a significant amount of water from the print paste. Part of this water and the reactive dye dissolved in it flows into the unprinted areas. The Fast Colour Salt couples almost instantaneously, and therefore produces sharp prints. Consequently, the reactive dye produces a halo around the mixed print produced by the combination of Fast Colour Salt and reactive dye. Cellulose ether thickeners are particularly suitable for this style, and the coagulating effect can be increased by the addition of salt to the impregnating bath, particularly salts of di- and poly-valent ions (Recipe 6.20). The addition of Leonil PAT (HOE) to the liquor improves the uniformity of bleeding of the reactive dye and gives a darker outline.

The colour specified in Recipe 6.21, for example, may be printed. Printing, drying and steaming then produces a brown print, resulting from a mixture of the red and the green, with a green halo.



In such styles, the greater the contrast of the halo the more impressive it appears. It is, therefore, an attractive proposition to add sufficient acid to the mixed reactive dye and Fast Colour Salt print paste in order to resist fixation of the reactive dye in the actual printed areas. If, for example, 30 g kg⁻¹ of citric acid are added to the print paste in Recipe 6.21, a green halo is obtained around a red area, instead of around a brown one. On the other hand, if 10–30 g phthalic acid is used a green halo is produced around a brown area containing red dots, which are due to the phthalic acid crystals.

As can be imagined, this style offers the colourist wide scope for the production of different effects.

Recipe 6.20

Naphtol AS	15 g
Monopol Brilliant Oil	10 g
Caustic soda (38 °Bé)	30 ml
Trisodium phosphate	7.5 g
Leonil PAT	40 g
Glauber's salt	60 g
Water to	1000 ml

Recipe 6.21

Fast Red Salt TR	40 g
Selected green reactive dye	45 g
Urea	100 g
Water	310 g
Remol AS	50 g
Thickener	500 g

6.5.3 The 'crimp' style

This style is characterised by the appearance of alternate plain and crinkled stripes in the fabric itself. This effect can be brought about by localised fabric shrinkage with appropriate swelling agents. For example, if cotton fabric is printed in a stripe pattern with strong caustic soda, it shrinks in the printed areas and thus causes the unprinted areas to cockle or crimp. The greater the shrinkage or contraction of the printed areas, the more pronounced the effect becomes.

A typical print paste for this style on cotton would be made up as shown in Recipe 6.22. When the fabric has been printed with the crimping liquor, it is plaited down on a conveyor belt in the tensionless state and allowed to dwell for about 30 min, during

Recipe 6.22

Water	213 g
Caustic soda (50 °Bé)	750 g
Starch ether	35 g
Wetting agent	2 g
	1000 g



which time shrinkage occurs. The goods are then rinsed, neutralised with acetic acid, rinsed again in hot and cold water and finally dried without tension.

The scope of this style can be widened by printing the crimping liquor on to unmercerised cotton fabric which has previously been dyed with, for example, selected reactive dyes. In this case the colour deepens in the areas printed with caustic soda in a manner corresponding to the phenomenon observed in the mercerising process.

A coloured and white effect can also be produced by the addition of selected direct dyes to the alkaline print paste; the use of other printing styles in conjunction with the crimp style enables a variety of different effects to be obtained. A crimp effect can also be achieved on nylon fabric by printing a thickened solution of resorcinol, care being necessary in handling this hazardous chemical.

6.5.4 Burnt-out styles

As the name suggests, this seems to be rather a drastic process in that it involves the destruction of all, or at least part of the fabric in the printed areas of the pattern. This, of course, can happen accidentally in various styles if the chemical processes are not properly controlled, but in the burnt-out or *devoré* style, the removal of part of the substrate is essential to the desired effect.

The principle is quite simple and entails the use of a print paste containing an agent that is capable of dissolving or destroying the fabric in the printed areas during subsequent processing [20]. The effect can be employed alone or in conjunction with printed head-colours, but in either case the extent to which the 'burn-out' is used must be controlled, so that the physical strength and structural stability of the fabric is not unduly impaired.

Any fabric can be subjected to such a process provided that a reagent is used that can be adequately controlled during processing (for example, one that can be suitably thickened to give a print paste), and which is not harmful to operatives or machinery.

Polyester/wool blends, for example, can be printed with a paste containing sodium hydroxide [21]. After drying the fabric is pressure-steamed at 120 °C for 15 min; where the wool has been printed it is destroyed and removed during the washing process.

A convenient approach with cellulosic fabrics is to apply a reagent that generates a strong acid during heat treatment after printing. This style was originally used on cotton to give novel dress fabric effects, but the introduction of polyester/cellulose mixtures has widened the scope considerably. The polyester portion of such mixtures is virtually unaffected by the reagents used to destroy the cellulose portion and allows the production of sizeable burnt-out effects with adequate strength and stability retained. Fabrics resembling lace have been produced for shirtings and other fashion articles.



A further development is to overprint a burnt-out pattern on to a polyester/cellulose blend material which has been previously dyed or printed with disperse dyes only. Such dyes or prints have a distinctly 'chalky' or delustrated appearance due to the undyed cellulosic portion, but in those areas where cellulose is removed by the burn-out the full depth of colour of the dyed polyester is revealed. This style can be extended further by overprinting a burn-out paste on to fabric which has previously been subjected to a discharge-resist process or in which the two fibres have been dyed to contrasting colours. Such a style offers a wide variety of possible effects.

A typical recipe for a burn-out print paste on cellulosic fabrics is shown in Recipe 6.23. After printing the fabric must be completely dried before the hot-air treatment. If the fabric is not completely dry at the carbonising stage the printed areas will not achieve the desired temperature for burning out and the result will be poor. If fabric for this style has been stored for a prolonged period, which may result in a degree of moisture gain, it should be redried before the burn-out procedure.

Recipe 6.23

Disperse dye	x g
Sodium hydrogensulphate	240 g
Water	120 g
Locust bean gum ether thickener	400 g
Glycerol	80 g
Carrier	0–15 g
Urea (only for colourless effect)	0–10 g
Water or thickener to	1000 g

REFERENCES

1. *The principles and practice of textile printing*, 4th Edn (London: Griffin, 1952).
2. R J Hannay and W Furness, *J.S.D.C.*, **69** (1953) 596.
3. R J Hannay, *J.S.D.C.*, **76** (1960) 11.
4. V A Bell, *Wool dyeing*, Ed. D M Lewis (Bradford: SDC, 1992) 332.
5. R Koch, *Textil Praxis*, **27** (1982) 1301.
6. J R Provost, *Rev. Prog. Coloration*, **18** (1988) 29.
7. Zeneca Colours technical information note D1613.
8. J R Provost, *Colourage*, (June 1987).
9. B Glover and J A Hansford, *J.S.D.C.*, **96** (1980) 355.
10. E Feess, *Melliand Textilber.*, **51** (1970) 197.
11. BASF TI/T214e.
12. H D Opitz, *Melliand Textilber.*, **71** (1990) 775.
13. German P 1 619 606 (1973).



14. German P 2 326 522 (1976).
15. M Hüchel, *J.S.D.C.*, **74** (1958) 640.
16. E Feess, *Melliand Textilber.*, **47** (1966) 1162, 1300.
17. V A Bell and D M Lewis, *Text. Res. J.*, **53** (1983) 125.
18. S, USP 2 726 133 (1955).
19. V A Bell *et al.*, *Schrif. Deutsch. Wollforschungsinstitutes*, **93** (1984) 102.
20. BASF TI/T104e.
21. V A Bell, *Review of Printing* (Ilkley: IWS, 1986).



Contents



Home

CHAPTER 7

The production and properties of printing pastes

Leslie W C Miles

7.1 THE REQUIREMENTS

All the different methods of printing normally require a liquid vehicle, in which the colorant is carried, and only in exceptional cases has it been possible to print dry colorant. In textile printing, the liquid is usually aqueous but in paper printing, as high-speed drying is necessary, more rapidly evaporated nonaqueous solvents have been used. The components of the liquid printing paste must include all necessary wetting, dispersing and fixing agents, in addition to the colorants, and may be soluble or insoluble. No separation of insoluble components must occur, and the incorporation of viscosity-increasing protective colloids helps in this respect. Finally, as the viscosity of the print paste must be suitable for the method to be employed and the substrate to be printed, appropriate amounts of thickening agents must be used.

'Viscosity' is a key word in this chapter and we have to consider why it is important, how it can be measured and how to achieve the required viscous properties. These are questions that, in the past, have been answered on the basis of experience rather than of scientific understanding, but with the availability of new materials and the need for improved productivity and reproducibility, experience alone is inadequate and understanding is required.

There are two essential reasons for the importance of the viscosity, and hence the flow, of a print paste. It affects the amounts of paste applied as well as the spread of paste, on the surface of the textile material and into its structure. For example, the paste in an engraved roller is completely transferred to the fabric pressed against the roller only if there is time for it to flow into the fabric structure. Highly viscous pastes flow slowly, so that at high speeds the time is often too short for total transfer to occur. Even at low speeds, transfer is viscosity-dependent [1]. If only a small volume of viscous paste is applied it may not spread to cover all the fibres of the three-dimensional fabric surface. The appearance of the print will be unsatisfactory if only the high spots of the



fabric surface are coloured and those parts of the yarn surfaces that are visible, but which lie at a lower level, are left uncoloured. The use of pressure helps in this respect, but the amount of pressure must be controlled for other reasons.

In practice, therefore, the upper limit of the viscosity is determined by the flatness of the fabric surface and the conditions of the printing process. The lower limit also depends on the process conditions, but is mainly determined by the need to keep the print 'smart', that is, having a sharp printed mark. All textile substrates are assemblies of fibres, and the spaces between fibres – especially where three fibres are parallel and in contact – have the dimensions and properties of capillaries. Liquids that wet the fibres are drawn by capillarity along these spaces, and the smartness of the print is lost if the viscosity is not high enough to control the spread.

It is clear, therefore, that some spread of print paste is inevitable, and indeed desirable, but that the extent must be controlled. Before considering in more detail the flow requirements of ideal pastes, it is important to recognise that the choice of materials for the production of viscous pastes will affect not only paste flow but also colour yield, because of their physical and chemical properties. Some knowledge of these properties is therefore desirable.

7.2 THICKENERS

Print pastes are traditionally made by weighing out and, if necessary, dissolving the colorants and auxiliary chemicals and then stirring them into the required weight of pre-prepared thickener. A thickener is a colourless, viscous paste made with one or more thickening agents. The use of terms such as thickener, and thin, long or short, to describe print pastes is of course descriptive rather than scientific, but is long established and a useful reminder that the materials being handled possess complex properties, not easily defined.

Four significantly different approaches may be used to produce thickeners, using:

- a low concentration of a polymer of high relative molecular mass (r.m.m.)
- a high concentration of a material of lower r.m.m. or of highly branched chain structure
- an emulsion of two immiscible liquids, similar to the emulsions used as cosmetic creams, or a foam of air in a liquid
- a dispersion of a finely divided solid, such as bentonite.

The first approach is the most important but all four have been used, sometimes in combination. Practical printers long ago discovered natural polymers with suitable properties and, by trial and error, acquired the art of using them. Because the natural products are variable materials and the requirements are complex and ill-defined,



experience and subjective judgements were essential. Now that the chemistry and physics of polymers are better understood, it is possible to select and use them more scientifically. We also have available a wider range of thickening agents, including completely synthetic polymers, and this has increased our knowledge. It must not be assumed, however, that our understanding of these complex materials and their behaviour is adequate.

In the selection of thickening agents, it is necessary to take into account requirements other than viscosity, which can usefully be classified in five categories: print paste stability, good adhesion of the dried thickener film, minimum effect on colour yield, ease of removal and acceptable cost.

7.2.1 Print paste stability

The thickener must be stable and compatible with the dyes and auxiliaries to be used. If a cationic dye is added to a thickener with anionic charges, the interaction is likely to change the viscosity and to produce insoluble complexes. Similarly, anionic thickeners cannot be used when metal salts such as aluminium sulphate (present in many azoic diazo components) are to be added.

The pH of the print paste must be considered, as some polymers, such as sodium alginate, are only usable within a limited pH range and form gels when acids or strong alkalis are added. Hydrolysis of the polymer chain links may also be significantly accelerated by acid or alkaline conditions.

Most natural polymers are also biodegradable. The micro-organisms responsible are present in the air, and thickeners provide nutrients and ideal conditions for their growth and reproduction. They produce enzymes that break down the polymer, with a consequent and often rapid fall in viscosity. To avoid this hazard thorough cleansing of thickener containers and the addition of preservatives, such as formaldehyde (methanal) or phenols (*o*-phenylphenol, for example), are recommended.

Natural starch pastes tend to gel and form insoluble aggregates over a period of time, because of the molecular association of linear polymer units. Such changes may occur slowly and not be immediately apparent, but print paste is usually required to be stable for at least one week.

7.2.2 Properties of the dried thickener film

Drying usually follows printing, and the fabric may be creased and flexed over rollers and tension rails before fixation of the print occurs. The thickening agent is deposited on the fabric surface as a dry film that sticks fibres together and contains colorant. Good adhesion to the fibre is required in order to avoid loss of colorant during



mechanical handling. Otherwise particles of coloured film may break off, leaving white spots in coloured areas and possibly giving coloured spots in unprinted areas. Freedom from these faults will depend on the flexibility of the film, in addition to its adhesion, and polymer films vary in both respects.

Linear polymers are adsorbed more strongly than highly branched polymers are, and therefore show good adhesion. However, the linear polymers that are useful thickening agents have large numbers of hydroxyl or carboxyl groups along the chain. Natural polymers of this type form brittle films because of substantial intermolecular hydrogen bonding. Thick films of such polymers on delicate fabrics can easily be broken when the fabric is creased, causing fibre fracture. Flexibility may be maintained by avoiding overdrying or by the inclusion of a plasticising agent.

The deposition of polymer films on a fabric inevitably causes some stiffening, and washing is normally required after fixation of the dye to remove thickening agent and any loose dye. If no wash-off is to be given, the thickener (and any binder) must be relatively soft and flexible. In the traditional printing of pigments, remarkably satisfactory results were obtained using albumen, which forms flexible films, as a thickener and binder. The use of emulsion thickeners has the undoubted advantage of leaving no stiffening film, and it is possible to choose synthetic-polymer binders for film softness (see section 5.2.2).

Emulsion thickeners are less popular than they were, however, because the evaporation of petroleum distillate into the atmosphere is more expensive and less acceptable than it was at one time. Paper printers use nonaqueous solvents with pigment binders, but their requirements are very different from those of the textile printer. Fortunately, many synthetic thickeners do not form such hard films as do the natural polymers.

7.2.3 Effect on colour yield

Printers have found that the fixation of dye is usually best achieved by steaming. Steam condenses on to the film of thickening agent, which swells and contains a miniature dyebath on the fibre surface. Some dye dissolves, and the next step is the diffusion of dye through the swollen film to the fibre surface [2]. Any affinity between the molecules of dye and thickening agent will reduce the speed of this diffusion process as well as the extent of dye transfer to the fibre. If both molecules have ionic charges of the same sign, the speed and efficiency of the process will be higher because of the mutual-repulsion effect. An example is provided by the use of sodium alginate for reactive dyes.

A thickener of low solids content gives higher fixation levels than one that has high solids content and otherwise similar properties. The former gives a thin film and



therefore a shorter mean diffusion path and less dye retention. Clearly, the degree of swelling of the film in steam will also affect the diffusion rate.

In addition to any effect on dye fixation, the thickener will significantly affect the penetration of print paste into the yarn and fabric structure, and this may have a dominant effect on colour yield. The highest colour yield (depth of colour for a given mass of colorant per unit area) is only obtained when penetration into and between the yarns is at a minimum. Penetration is viscosity-dependent for any thickener, but some thickeners appear to restrain penetration more than expected on the basis of viscosity. This is so for starch-based thickeners, and has been attributed to their gel-like structure [3]. In the case of printed pigments, the colour yield may also be significantly affected by the transparency of the thickener–binder film and by any tendency of the thickener to promote or prevent aggregation of the pigment.

The print fixation stage is discussed in Chapter 8.

7.2.4 Ease of preparation and removal

The time taken to prepare a thickener, and the precautions required to ensure that the paste has satisfactory and consistent properties, are variables that have greater significance today than in the past. The extent to which a thickening agent is removed in a high-speed washing process, especially after a high-temperature steaming operation, is also a vital consideration in the selection of thickening agents.

Natural starches are cheap, but to burst the grains and obtain a proper dispersion requires time or special equipment. It is also difficult to redisperse starches and remove them from the printed fabric. The physical and chemical modification of starch, and of other natural polymers, has therefore become common practice in order to provide products that are readily dispersed and have more consistent properties (as a result of blending to a standard level).

The removal of thickening agents can also be facilitated by introducing a second component in the thickener. Small additions of sodium alginate, for example, improve the removal of starch. The introduction of dispersing agents, or of hydrogen-bond breakers such as urea, can also be useful.

The actual preparation of pastes is dealt with in section 7.8.

7.2.5 Cost

Traditionally, when labour costs were low, it was common to look only at the cost of the thickening agent itself and the cheapest materials were widely used. It must already



be obvious, however, that it is essential to consider many other aspects to decide which material will give the required quality at the lowest overall cost. The concentration to be used, cost of preparation, stability, print penetration, colour yield and ease of removal can in total be more important than the basic price of the polymer. The biological oxygen demand of the effluent, due to thickener removed in the washing-off operation, can also be a vital parameter.

7.3 RAW MATERIALS: POLYSACCHARIDES

The availability of carefully standardised, modified natural products or synthetic thickening agents can reduce the printer's problems significantly, but in some situations the locally available materials will be preferred. A review of the properties of the many products and their derivatives is therefore included here. Some knowledge of the traditional thickening agents is also helpful in that they illustrate general problems and properties more clearly than the more recently developed materials do.

Nature has provided large quantities of many polymers that are soluble or dispersible in water to give viscous pastes. Each plant species synthesises one or more polysaccharides from the constituent sugars, and some plants (potatoes, for example) produce them in purity and in quantities that make extraction very simple.

The sources of useful polysaccharides may be classified as:

- plant seeds which contain starch or similar products as a food reserve and may be cultivated for industrial use (such as guar)
- seaweed, the only source of alginate
- plant gum exudates, of which the best known are gum arabic and gum tragacanth
- the cultivation of selected micro-organisms, carried out under controlled conditions, converting waste carbohydrate into useful polymers (such as xanthan)
- cellulose pulps, from which cellulose ethers are produced.

The relative importance of these different sources changes with time, as costs of collection, competition with the food and other industries and the technical need for particular properties change.

The polysaccharides may be homopolymers, composed entirely of one sugar unit, or heteropolysaccharides with two or more hexose or pentose units assembled in a relatively ordered sequence. The polar side-groups may all be hydroxyls, as in starch, cellulose and guar gum, or they may include carboxyl groups as well, as in alginate and gum arabic. Less frequently, other water-soluble groups are found.

An equally important structural feature is the degree of chain branching, which affects the solubility, film and viscosity properties. Long, linear polymers give high viscosity at low solids contents, but the viscosity falls with increasing shear. Highly



branched polymers, such as amylopectin, are more soluble and are required in higher concentrations for a given viscosity, but show less change under shear.

The interactions of polysaccharides and water are complex, but important. Water vapour is adsorbed from the atmosphere, typically to the extent of 10% of solid mass, by the accessible hydroxyl groups. In liquid water, swelling occurs as accessible segments of the polymer become fully hydrated and move away from adjacent chains. The kinetic energy of these segments then causes the rupture of some intermolecular hydrogen bonds and more chain segments can be solvated. Where polymer chains are well ordered and bonded, however, especially in crystalline regions, the structure will be maintained and such insoluble units may be linked together, forming a gel.

If enough of the intermolecular forces can be broken, the polysaccharide goes into colloidal solution. A principal feature of colloidal solutions is their instability. For example, starch pastes obtained by heating tend to form gels on cooling, as new intermolecular bonds are formed. The intermolecular bonds are of two types: hydrogen bonds and hydrophobic bonds. A proper understanding of the latter depends upon the recognition of the structure of water and the effect of solutes on that structure.

Frank and Wen proposed a 'flickering cluster' model of water structure with short-lived, ice-like molecular clusters of varying sizes in equilibrium with single water molecules [4]. At ordinary temperatures between 70 and 90% of the water molecules are assumed to be in clusters at any given moment. Organic solutes of significant size and hydrophobic character, including many alcohols, are believed to cause a tightening of the water structure around the molecules, because repulsion of the nearest water molecules encourages their orientation and hydrogen bonding. It is envisaged that each solute molecule occupies a cavity in the solvent.

There will then be a tendency to 'water-structure-enforced association' [5], because the repulsive interactions and the cavity surface areas can be minimised, and the entropy maximised, when two or more solute molecules together occupy one slightly larger cavity. In the case of polymer molecules, it will be chain segments, rather than whole molecules, that are thus associated by hydrophobic bonding. Many of the polysaccharides show sufficient hydrophobic character to engage in such intermolecular bonding, in spite of their many hydroxyl groups. Cellulose molecules are a clear example, their flat, ribbon-like shape with all the hydroxyl groups at the ribbon edges providing large central hydrophobic surfaces that associate readily. In the same way, flat dye molecules can be adsorbed on to the hydrophobic surfaces.

When the equilibrium between hydrophobic and hydrophilic character is delicately balanced, the addition of electrolytes can have significant effects. Thus magnesium sulphate reduces the solubility of amylose, because both ions compete with it for water of solvation. On the other hand lithium iodide, and other salts high in the lyotropic series, have a solubilising effect as these ions are strongly adsorbed on to the polymer.



7.3.1 Starch and its derivatives

Native starch is, after cellulose, the most abundant of the plant products and has therefore provided a readily available and low-cost source of industrial materials [6]. Starches have long been used in textile print pastes, but are less important than they were because of the increased availability of technically superior materials, some of which are starch-based.

It is sometimes argued that the importance of starch for human consumption and the continuing expansion of the world's population make it unlikely, even wrong, that its industrial use should continue. Such a simple conclusion may not be justified, however, because of the complexity of the relationships. Increased demand causes an increase in price, if supply cannot be readily increased, but also stimulates production and the search for alternative materials.

Starch is a homopolymer of glucose (D-glucopyranosyl) units, with most of the units joined by α -D(1 \rightarrow 4) linkages. Most starches contain 20–30% of the linear chain polymer, known as amylose (7.1 in Figure 7.1), together with an irregularly branched material, amylopectin (7.2 in Figure 7.1). Amylopectins have an α -D(1 \rightarrow 6) linked branch for each 15–30 glucose units. So-called waxy starches contain little or no amylose. Separation can be achieved by fractional solution or precipitation.

Whereas, in cellulose, the β -D-glucoside linkages give a nearly flat, ribbon-like molecule, in linear starch segments the α -D(1 \rightarrow 4) linkages and ${}^4C_1(D)$ chain conformations introduce a natural twist. Under certain conditions, a tightly coiled

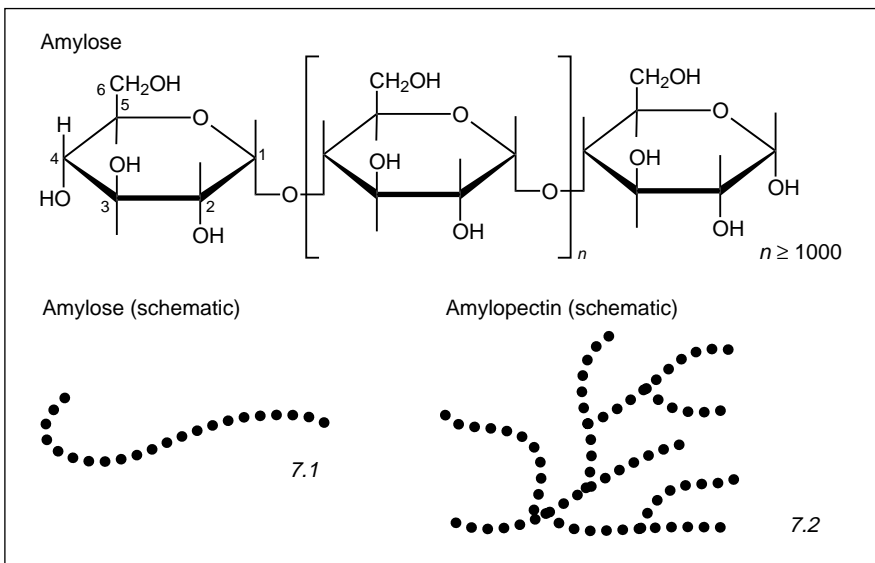

Figure 7.1 Amylose and amylopectin

helix is stabilised by hydrogen bonds between the C-2 and C-3 hydroxyl groups on adjacent chains.

In the natural state, starch is always found in a strongly aggregated state, organised in granules around crystallisation nuclei. The granules of each type of starch (rice, potato, wheat and so on) have a characteristic structure which is readily identifiable under the microscope. It is necessary to break down the granules, by boiling or by grinding and dispersion in hot water, to obtain smooth, viscous pastes. If such a paste is dried rapidly, cold-water-dispersible starches are obtained, but slow drying allows substantial reaggregation and crystallisation to occur and the product is no longer dispersible in cold water. The use of hydrogen-bond breakers, such as urea and strong alkalis, will assist dispersion in water.

Starch pastes containing amylose, as mentioned above, are not stable and may form gels and precipitates of amylose aggregates. This phenomenon has been described as retrogradation and is clearly undesirable in print pastes. The precipitates are not easily redissolved. Stability can be improved by additions of formaldehyde, probably by formation of hemiacetals.

Amylopectin, by contrast, forms clear, stable solutions, not subject to retrogradation. Chain branching evidently prevents the molecular orientation and regularity of intermolecular bonding necessary to cause gelling and precipitation. When in solution, the amylopectin molecules can be pictured as approximately spherical, with a relatively dense core and flexible, deformable, outer regions of solvated chain branches.

Different native starches have different proportions of amylose and amylopectin, and probably also different degrees of chain branching and r.m.m. distributions, so differences may be observed in paste stabilities, flow and film properties. Measured r.m.m. values range from 2 to 6×10^5 for amylose and 4.5×10^4 to 4×10^8 for amylopectin.

Although starch has certain disadvantages for use as a thickening agent, it does have the advantage of giving high colour yields. This is the result of its aggregation and very limited penetration into textile yarns and therefore the retention of dye on the fabric surface. However, it is usually desirable to reach a compromise between high colour yield, with substantial susceptibility to crush and poor levelness, on the one hand, and low colour yield with good penetration, little crushing and good levelness, on the other. A traditional method of achieving such a compromise was to use a mixture of starch and gum tragacanth.

7.3.2 British gums

An alternative approach to improving the properties of starch has been to bring about structural changes by simple roasting processes.



The original British gums were produced by heating batches of dry starch at 135–190 °C, with stirring to achieve uniform roasting, for 10–24 h. The process can be accelerated by addition of trace quantities of acid, and can then be carried out continuously on a conveyor belt. The use of more than trace quantities of acid leads to more hydrolysis and the formation of the so-called dextrans, which are of low r.m.m. and can be used as adhesives.

The significant chemical changes have been shown to be random hydrolysis of 1→4 bonds and the formation of 1→6 linkages (Scheme 7.1). The consequences are increased water solubility, reduction in r.m.m., more highly branched molecules, and some increase in the content of reducing end-groups. A range of products, pale to dark-brown in colour, requiring increasing concentrations for a given paste viscosity, can be blended to give the required properties.

British gum pastes have good stability to alkali and have been used for printing vat dyes. For reducible azo dyes, additions of oxidising agent must be made to avoid destruction of dye. In resist printing, when a high-solids-content thickener is desirable to act as a physical barrier, British gums have often been selected.

7.3.3 Starch and cellulose ethers

The roasting of starch changes its properties significantly, and increased dye penetration results when such modified starches are used in printing. Increased solubility can alternatively be obtained by controlled etherification, with only slight reduction in r.m.m., viscosity and colour yield. A low degree of substitution (DS 0.1–0.3) is sufficient to prevent molecular association, particularly when the substituent is bulky. Ethers are readily produced by reaction with monochloroacetic acid, epoxyethane (ethylene oxide) or dimethyl sulphate in the presence of sodium hydroxide. The first of

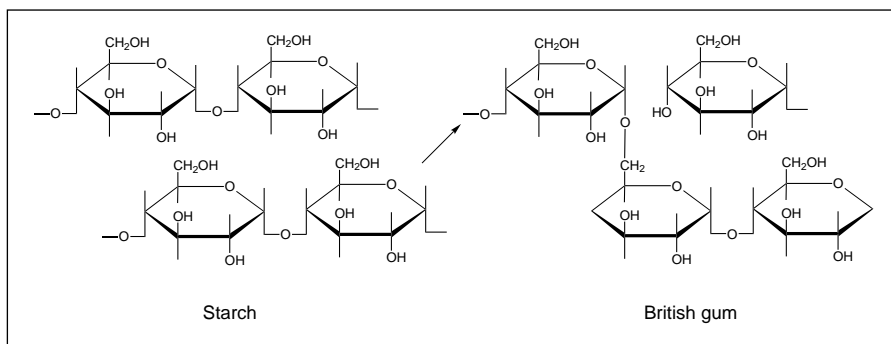

Scheme 7.1

these reagents gives the much-used carboxymethyl ether, which is, of course, anionic in character. A concentration of 6% gives a paste of suitable viscosity.

Zonnenberg has described the properties of such starch ethers as ideal in respect of colour yield and solubility [7]. They have been recommended for use in mixtures with galactomannans or alginate, to increase colour yield.

Cellulose ethers of appropriate r.m.m. can also be used, and have been selected for high-speed printing on engraved-roller machines because the paste viscosity is greatly reduced at the moment of printing, and transfer from the engraving to the fabric is more complete than for many thickeners.

7.3.4 Locust bean gum

The carob tree *Ceratonia siliqua* is a leguminous plant that grows on rocky soil and requires little rainfall, but does not produce much fruit in its first 15 years. The Mediterranean area provides the bulk of the world supply, which has been known by the names of carubin, gatto, Tragon, Tragasol and St John's Bread, as well as locust bean gum.

The beans consist largely of pulp (90%) and only 7% by weight of kernels (seed), and the kernel is composed of husk (30%), germ (25%), and endosperm (45%), which is the desired gum. The seeds must be dehusked and split and the germ removed, before the endosperm is ground.

The commercial gum contains about 88% of D-galactomannoglycan with small amounts of other carbohydrates and of protein. It is a linear polymer of 1→4-linked D-mannose units with about every fourth unit carrying an α -D-galactose unit on its carbon atom number 6 (7.3, page 252).

The typical r.m.m. is 300 000, and there is enough crystallinity to require the use of temperatures of 45 °C or higher for complete dispersion in water. Etherification has therefore been used to produce readily dispersed materials.

Because the locust bean gum is a nonionic polysaccharide, pH has little effect on the viscosity over the pH range 3–11. Pastes of useful viscosity are obtained at concentrations of about 2%. Additions of sodium salts have little effect on paste viscosity, but complexes (Figure 7.2) are formed with borates, producing gelling that has been exploited in the two-stage fixation of vat prints.. The borate ions complex with *cis*-hydroxyl groups of two mannose chains to form crosslinks, which are broken in the presence of low-r.m.m. glycols such as glycerol.

7.3.5 Guar gum

Guar gum is chemically similar to locust bean gum (it is also a galactomannan) and like locust bean gum is a very useful thickening agent. The guar plant *Cyanaposis*



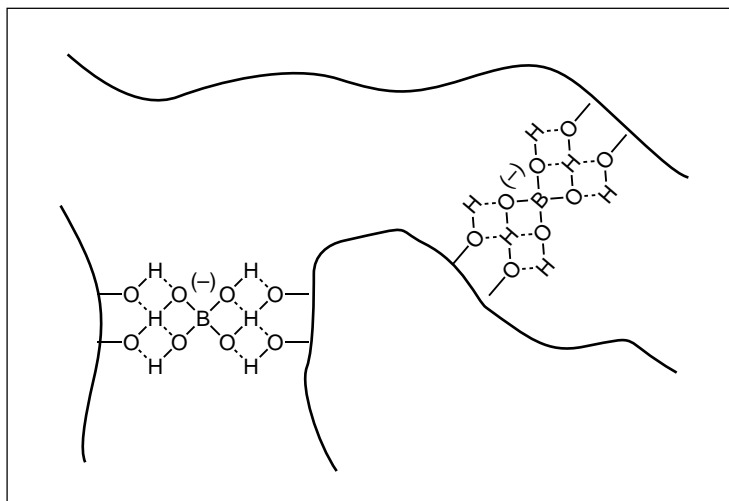

Figure 7.2 Borate dihydroxy complex (diagrammatic)

tetragonolobus is an annual leguminous plant which has been grown for centuries in India and Pakistan for food, and as a cash crop in Texas since 1946. It needs very little surface water and can be used as a rotation crop to improve soil fertility by fixing atmospheric nitrogen, and is therefore of interest in semi-arid regions where less hardy crops perish.

Each bush bears many pods, each containing between six and nine seeds. From each seed, it is necessary to remove the husk and the germ to obtain the endosperm (40% by mass). This is guaran (7.4, page 252), in which the galactose side units are approximately twice as frequent along the mannan chain as in locust bean gum. The r.m.m. has been reported as 220 000.

In contrast to locust bean gum, guar gum can be dispersed in cold water, which is probably because the greater number of side units reduces the amount of molecular association. Although its cold-water dispersibility is a major advantage, dispersion must be carried out with care in order to avoid the formation of lumps. The hydration of the powder should not be faster than the rate of surface wetting. The hydration, and the swelling, are slower in low-temperature water, so that the problem of too rapid swelling and lump formation is greater in summer than in winter. Efficient stirring accelerates the surface wetting, but excessive speed and time of stirring will cause fission of the chains and loss of viscosity. The time required for complete dispersion, and maximum viscosity, is also temperature-dependent; if 30 min is sufficient at 25 °C, it may be necessary to allow 60 min at 15 °C.



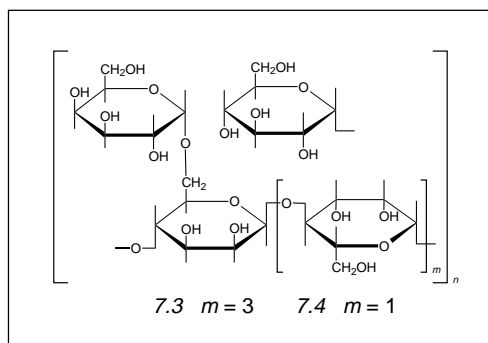

Modified products are marketed, for which the swelling is delayed by up to 5 min, allowing wetting and dispersion to be completed before swelling starts. Even safer are the 'add-acid' gums, which can be produced by introducing small amounts of borate, and which swell only when the pH is reduced.

7.3.6 Alginates

The principal carbohydrate component of brown Phaeophyceae seaweeds is alginic acid. Different carbohydrates, agar and carrageen, are found in the red seaweeds. Some species of bacteria also produce alginates. Extraction of the alginic acid from the brown seaweeds is by digestion with solutions of sodium carbonate. Purification can be accomplished by precipitation as the calcium salt, reconversion to the free alginic acid and neutralisation to give the desired salt.

Commercially produced high-viscosity alginates have r.m.m. values of over 150 000, but lower-r.m.m. materials are also sold. The monomer units are D-mannuronic acid (7.5) and L-guluronic acid (7.6), in a 1→4-linked linear polymer with blocks of β-mannuronide, α-guluronide and alternating copolymer segments. The last-named segments are apparently the most readily hydrolysed. The relative amounts of the three structural blocks vary with species and age of the seaweed, but the typical ratio of mannuronic to guluronic units is 1.5:1.

Sodium alginates have become very important for print paste thickening because of their ready solubility, even after high-temperature fixation treatments. They are especially important for pastes of reactive dyes because the extent of interaction is very small. This is due to the absence of primary hydroxyl groups and to the repulsion of dye anions by the ionised carboxyl groups of the polymer under alkaline conditions.

The viscosity of sodium alginate paste will depend on the r.m.m., concentration, method of preparation (high temperatures should be avoided to maintain the r.m.m.),

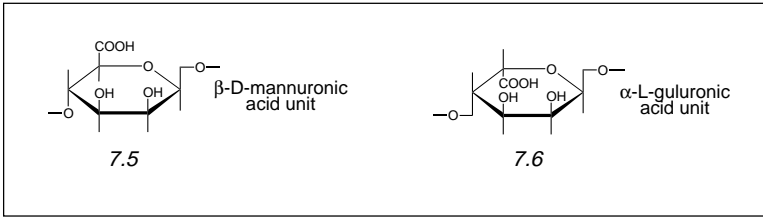

shear stress and the presence of other ions. Some high-viscosity products contain a significant concentration of calcium ions, which allow the user to modify the paste properties. The crosslinking effect of the calcium ions increases the viscosity and the pseudoplasticity of the paste, but additions of controlled amounts of polyphosphate (or other sequestering agents) reduce these effects (Figure 7.3).

The stability is good between pH 4 and pH 10, but gels are formed above pH 11.5 and below pH 3.5. Buffered alginates are sold for use in strongly alkaline conditions. Alginate pastes are compatible with a wide range of materials, including starch, cellulose ethers, tragacanth and galactomannan gums.

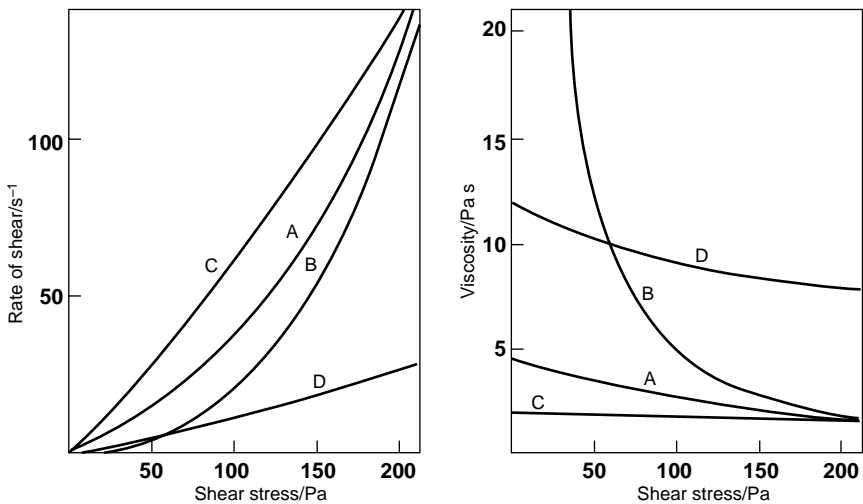

Figure 7.3 Effect of r.m.m., concentration and calcium ions on the viscosities of sodium alginate pastes; A: high r.m.m., concentration 2%, Ca sequestered
 B: high r.m.m., concentration 2%, 12% of alginate as Ca salt
 C: low r.m.m., concentration 6%, Ca sequestered
 D: low r.m.m., concentration 8.3%, Ca sequestered

Commercial materials of high r.m.m. give pastes of suitable viscosity for printing at around 2% concentration, whereas those of low r.m.m. may be used at perhaps 6%.

7.3.7 Gum arabic

Wounds in the bark of acacia trees exude a gum that has interesting properties. In spite of its very high r.m.m. (over 250 000), the polysaccharide in the gum is extremely soluble in water (50%) and shows Newtonian behaviour. Its structure is that of a 1:3 galactan (coiled) chain with numerous side-chains, including glucuronic acid units, of two-, three- and four-unit lengths. Molecular association of such a structure is impossible, so that hydration and solubility are readily achieved and no orientation of the molecule occurs under shear.

Gum arabic has been used as an adhesive more than as a thickening agent, for which purpose concentrations as high as 40% may be required. Mixing with starch is not recommended as the polymer may separate.

Karaya gum (20%) has been used as a cheaper alternative. Crystal gum is a pre-swollen and purified material made from vegetable gums such as Karaya, to be readily soluble and more reproducible in properties than the original gum.

7.3.8 Gum tragacanth

Tragacanth is also an exudate, in this case from *Astragalus gummifer*, and is obtained in the form of hard, translucent plates that swell in water but require boiling, for perhaps 6 h, to produce a homogeneous dispersion. The solids content required is much lower than for gum arabic, and may be as low as 6%. It is also a polyglycuronan, but it is less sensitive to additions of electrolyte than gum arabic and must have a less highly branched structure. An additional reason for its high, pseudoplastic viscosity is the presence of dispersed fibrils of cellulose, which are readily removed by centrifuging.

7.3.9 Biosynthetic gums

Just as the amylase used for desizing is now primarily obtained by the culture of selected bacteria, and the product is superior in many ways to that obtained from malt, so is the biosynthetic production of thickening agents of some importance.

Some species of bacteria produce alginates as extracellular mucilages, but production in this manner has not provided an economic route.

Xanthan gum, however, has been on the market since 1964. This is a cold-water-soluble polysaccharide, with a r.m.m. in excess of 1×10^6 , containing glucose, mannose



and glucuronic acid units in a branched-chain structure. It gives high viscosity at low solids content, is little affected by rise in temperature or addition of electrolyte, and is stable over the pH range 1–11. The micro-organisms that produce xanthan gum can be cultivated on waste carbohydrate material.

7.4 VISCIOUS EMULSIONS

Oil and water do not mix, if enough energy is used to break up one component of the mixture into small droplets, which are dispersed in the other component. Such simple emulsions are unstable, but their stability and ease of preparation can be considerably increased by the incorporation of a surface-active emulsifier. The nature of the emulsifier and the ratio of the volumes of the two immiscible liquids determine which liquid will be dispersed (the dispersed phase) in the other (the continuous phase).

Where the dispersed phase forms 70% or more of the whole, the emulsion will have significant viscosity, because work must be done to deform the droplets as they are moved relative to a stationary layer. It can be shown that if the droplets are spherical and of equal size, an emulsion containing 74% (by volume) of droplets requires a close-packing structure. Examination of emulsions under a microscope shows, however, that there are often small droplets in the spaces between the larger droplets, and that deformation from the spherical occurs. This explains how emulsions with 90% of inner phase may be formed.

The droplets range in diameter from 100 to 7000 nm, and the smaller they are the higher is the emulsion viscosity. A useful indicator of particle size is the emulsion colour, which changes from creamy-white to bluish-white as the size is reduced. Viscosity depends on volume ratio, on particle size and also on the emulsifier. Dawson, in an excellent review, has shown that anionic emulsifiers can produce higher viscosities than nonionic emulsifiers, and that this can be understood to be due to the greater mutual repulsion induced [8].

The emulsifier forms a film between the two liquids, reducing interfacial tension. Each molecule of emulsifier contains a region that is hydrophilic and another that is hydrophobic (lipophilic), and it is the balance between the dominance of these regions that determines the relative solubilities of the substance in oil and in water. This hydrophile–lipophile balance (HLB) has been evaluated for many surface-active agents and expressed in a standard manner, over the range of 1 to 40 [9]. Experience has shown that compounds with HLB values of 3–6 stabilise water-in-oil (w/o) emulsions, and those with values of 8–18 are effective for oil-in-water (o/w) emulsions.

Stabilisation can be achieved not only with conventional surfactants, but also with certain finely divided powders, many proteins and natural gums, and some synthetic polymers.



7.4.1 Emulsions for pigment printing

In 1937 it was shown that w/o emulsions could be used to thicken pigment printing pastes. Previously natural polymers had been used, but the prints were dull and stiffened in handle. Albumen was one of the best materials, giving a flexible film with good pigment-binding properties, but it was expensive. By using emulsions of water in white spirit (the petroleum distillate fraction boiling at 150–200 °C, referred to as 'heavy benzene' in the German literature), only the emulsifier remained when the thickener film was dried. Suitable polymer binders (see section 5.2.2) were incorporated as pigment binders and the fabric stiffening could be minimised by selecting a polymer forming a soft film and by restricting the penetration of paste so as not to stick the yarns together.

The use of emulsions with white spirit as the outer phase was unpopular with printers, however, as the cleaning of printing equipment could be troublesome. From about 1950, attention was turned to o/w emulsions and, in spite of the increase in cost due to the larger white spirit volume fraction, they have been developed into the more successful systems. Higher visual depths of colour and fastness properties were important factors.

The larger volumes of white spirit make it more essential to remove the vapour efficiently while drying, in order to avoid the build-up of explosive concentrations in air at the baking stage.

7.4.2 Emulsions for substantive dyes

The successful use of emulsions for thickening pigment printing pastes was followed by application to the printing of a wide range of dye classes. The incorporation of a film-former is necessary in order to prevent removal by abrasion of the dye deposited on fibre surfaces, before fixation occurs. Low concentrations of natural or synthetic thickeners are suitable for this purpose. The viscosity of the aqueous continuous phase is thereby increased, the emulsion stability is improved and the volume of white spirit may be reduced.

Because the prints produced require a washing-off treatment, and the film-former is thereby removed, the extent of viscosity increase due to the presence of film-former may be varied in order to obtain optimum printing properties. When the 'short' flow behaviour of an emulsion paste does not give a satisfactory print the printer may use a so-called 'half-emulsion', in which approximately equal quantities of stock emulsion and an alginate or guar paste are mixed. The 'half-emulsion' also offers the advantages of higher colour yield and faster drying, as compared to those obtained with a 100% natural thickener.



7.5 VISCOUS FOAMS

An alternative to an emulsion of immiscible liquids is a foam of air bubbles in an aqueous outer phase [10]. It is essential to use a surface-active agent and subsequent mechanical action to obtain the appropriate bubble size (about 50 μm diameter), and to control the volume of air in the foam relative to liquid (the blow ratio). The use of foams for the application of finishes [11] and in the dyeing of pile carpets [12] is well established, but their use in printing is more difficult, because less than 100% cover is required. During screen printing the paste is sheared under the squeegee; some is pushed through the screen but some is sheared again and again before it reaches the fabric. The stability of the foam is therefore a critical parameter. The stability, and the viscosity, of the foam can be increased by the addition of a small amount of a thickening agent or of a long-chain alkanol.

The advantages of foam printing are attractive: fabric absorbency is less critical; levelness, depth and handle of the prints are improved; drying costs and effluent BOD levels are reduced. Printers have, however, found that there are disadvantages with shade matching and longer downtimes, as well as the need for specialised equipment [13]. Some success has been achieved in India with a system that requires only a paddle stirrer [14]. It may be that application by block printing gives minimum difficulties. Greater use of this highly attractive route will depend on the solution of the reproducibility problems.

7.6 SYNTHETIC-POLYMER THICKENERS

Uncertainties concerning the availability and price of natural thickening agents, and the effect of increasing petroleum prices and environmental protection measures on the use of emulsions, encouraged the development of synthetic agents.

One material that has been used to a limited extent is poly(vinyl alcohol), especially on nylon fabrics. The preparation of the paste in bulk requires time and care, however, and concentrations up to 20% may be required.

Copolymers of acrylates have been used more widely. Relatively low-cost copolymers of methacrylic acid and ethyl acrylate, for example, give low-viscosity dispersions in water in which the molecules are randomly coiled. On addition of alkali, the carboxylic acid groups are ionised and the resultant mutual repulsion of negatively charged centres causes extension of the polymer chains and substantial increases in viscosity. The viscosity obtained, however, is critically dependent on the amount of alkali added. Verbrugge has shown that the fall in viscosity is a consequence of the polymer going into solution, as a result of the solvation and intermolecular repulsion of the carboxylate ions [15].



High viscosity is obtained with copolymers of optimum ratio between acid and ester units, but the viscosity is too sensitive to pH for industrial use. The molecules can be prevented from going into solution, however, by introducing a small number of crosslinks, for example, by incorporating a bifunctional monomer. Berlenbach has described the production of a thickening agent by copolymerising 1 mol acrylic acid and 0.01 mol divinylbenzene (Scheme 7.2) [16].

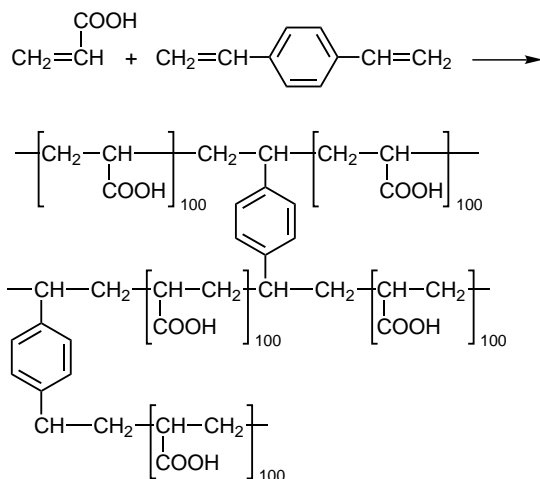

Scheme 7.2

Polymers with similar properties have been produced from maleic anhydride and an olefin, crosslinked with a diamine [17].

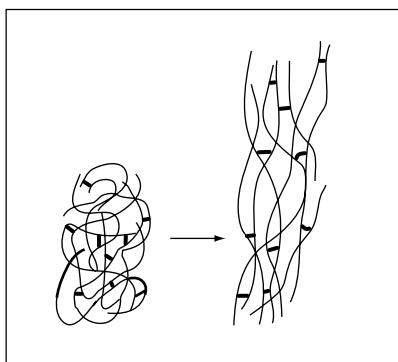

Figure 7.4 Chain straightening and swelling of a crosslinked poly(acrylic acid) on neutralisation

Such products are believed to consist of bundles of polymer chains, held together by the crosslinks. The dry materials are powders that swell in water, and are not readily dispersed unless the particles are pre-wetted in a nonswelling liquid, but swell even more powerfully when neutralised (Figure 7.4). One successful commercial product [18] is a liquid dispersion of acrylic polymer particles in a hydrocarbon solvent. It has a high solids content (50–60%) but its mobility is high, and when it is stirred into water a viscous paste is produced. The fully swollen molecular bundles may be sausage-shaped



and of substantial size, with large numbers of water molecules immobilised within and around them. Consequently high viscosities are characteristic for solutions of low solids content, and 1% pastes may be used for printing. Such polyelectrolyte thickeners are used to replace (completely or partially) emulsions in pigment printing, with only limited increases in fabric stiffness. Because they behave like emulsions, the two types of thickener have been called 'dispersion thickeners'. The swollen particles, of similar size to emulsion droplets, can be considered as a dispersed phase of water molecules, held by the polyelectrolyte, within a small continuous phase of mobile water. The ionic charge on the particles can be large enough to immobilise almost all the water molecules, and the paste then has the consistency of a gel. Slight shear, such as that exerted by stirring by hand, can introduce sufficient energy to overcome the bonding energy of the water sheath, and the paste flows.

The polyacid is usually neutralised with ammonia so that, during the drying and baking of the pigment print, the free acid is largely re-formed. A print with higher wash fastness is obtained than if neutralisation with a nonvolatile alkali, such as sodium hydroxide, had been employed. The presence of free acid during baking also has the consequence that the catalyst that is normally required for binder crosslinking can be omitted.

The use of polyelectrolyte thickeners in print pastes containing dyes rather than pigments is less attractive because of their sensitivity to electrolyte content. Even the electrolyte in a conventionally standardised disperse dye can cause a substantial drop in viscosity. By replacing the anionic dispersing agent in disperse dye formulations by nonionic products, however, the dye manufacturers have been able to reduce this problem to acceptable proportions [19].

When suitable dyes are used, and the techniques for producing print pastes of reproducible viscosity are mastered, the synthetic thickeners are found to give significantly higher fixation and colour yields, with disperse dyes on polyester fabrics, than natural polymer thickeners. The principal reason is likely to be that the thinner the film of thickening agent, the greater is the transfer of dye from the film to the fibre. This will be especially true for the low-humidity, high-temperature conditions used for fixation on polyester fibre (see Chapter 8).

The improved dye fixation may, however, be accompanied by poor resistance to abrasion before fixation occurs. A compromise may therefore be dictated, with addition of a smaller polyelectrolyte or a film-forming dispersion (perhaps a polyacrylate) to improve the abrasion resistance.

If high dye fixation can be obtained, it may be possible to omit the final washing-off process. This will not normally be the case, and the removal of thickener, in addition to unfixed dye, will be necessary. By using sodium hydroxide, rather than ammonia, to



neutralise the thickener, a faster and more complete removal is obtained. Soft water is also highly desirable.

In the case of dyes other than of the disperse class, the electrolyte effect is more serious, but satisfactory results can be obtained by selection of the best polymer [18] and increasing the concentration of thickener. The fixation of reactive dyes has been found to be increased when alginate thickeners have been replaced by synthetic products. It is unwise to use ammonia to neutralise the polyacid when printing reactive dyes as loss of the ammonia in drying can reduce the fixation.

The effect of electrolyte content on viscosity is greatest with the thickeners of large molecular size and correspondingly low solids content. The charge on the molecular surfaces is partially neutralised by counterions and fewer water molecules can therefore be held.

7.7 PRINT PASTE RHEOLOGY

7.7.1 Viscosity

An early student of rheology (the science of flow) was Sir Isaac Newton, who showed that for each simple liquid there is a constant coefficient of frictional resistance to flow, which we call its viscosity. An understanding of this resistance to flow is most simply obtained by considering the movement of liquid between two flat plates, when the top plate is moved. The liquid is sheared, as shown diagrammatically in Figure 7.5.

The shearing force (F) which gives the top plate (of area A) a velocity v relative to the lower plate, is dissipated as heat in overcoming the internal friction between the imaginary thin layers of liquid. The layer adjacent to, and in good contact with, the top plate also moves at velocity v , but intermediate layers move more slowly, and the lowest layer remains stationary.

The viscosity, η , of the liquid is defined as the ratio of the applied shearing stress S ($= F/A$) to the rate of shear produced, D ($= dv/dx$), also known as the velocity gradient (Eqn 7.1):

$$\eta = \frac{S}{D} \quad 7.1$$

The viscosity of a liquid that requires a shearing stress of 1 N m^{-2} to produce a rate of shear of 1 s^{-1} is 1 Pa s (10 poise).

The viscosity of liquids is often determined by measuring the velocity of flow through a capillary tube, the calculation being based on a simple extension of the Newtonian analysis given above. The velocity will be high in the middle and low near the walls, a phenomenon readily appreciated by anyone who has rowed against the



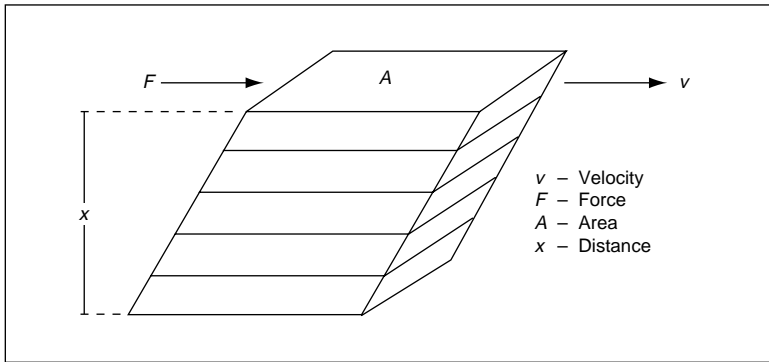

Figure 7.5 Diagrammatic representation of a shearing force producing movement of (imaginary) layers of liquid, relative to their adjacent layers

current in a river. Further, the velocity gradient will not be constant, but high near the walls and zero in the middle. For simple Newtonian liquids such as water, glycerol, sugar solutions and many oils, the viscosity is independent of the rate of shear. Typical print pastes are described as non-Newtonian, because their viscosity changes as the rate of shear is changed. Measurement of their viscosity, therefore, is not so straightforward. Information is required, nevertheless, because the viscosity of a print paste during the shearing that occurs in the printing process will determine the quality of the print.

7.7.2 Viscometers

If viscosity measurements are required only to assess the reproducibility of batches of a given thickener or print paste, then any simple, convenient type of viscometer may be satisfactory. When problems, new products or procedures are investigated, however, an instrument that can provide a more complete picture of flow properties is highly desirable.

Instruments of several types may be used [20], but in many respects the cone-and-plate type is especially suitable. The principal features of such a viscometer are shown in Figure 7.6.

A small sample of paste is placed on the centre of a flat, temperature-controlled plate (A), which is then raised to bring it almost into contact with a cone (B). The angle between A and B (α) is small (typically 0.3°) and the size of cone is chosen to be suitable for the conditions of measurement; it may be of 1–5 cm radius (r).

A motor and gearbox provide a range of precisely known velocities, and the drive shaft incorporates a torque transducer giving an electrical output that is proportional to

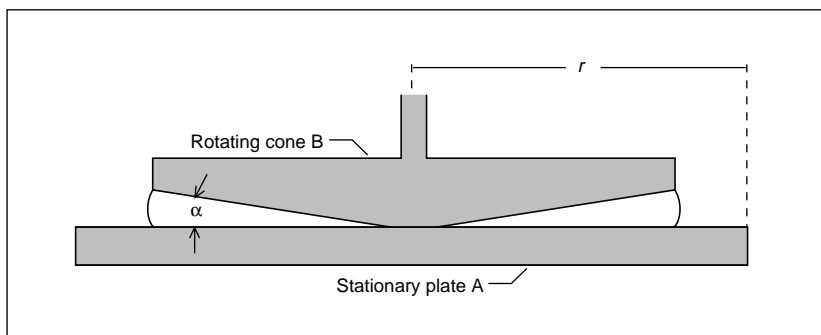

Figure 7.6 Diagrammatic illustration of the cone-and-plate viscometer

the force required to maintain the chosen velocity against the viscous drag. From the velocity and the known dimensions of the cone, the constant velocity gradient is obtained, and the shear stress is calculated from the torque and the surface area of the cone. The small space between plate and cone must, of course, remain filled and not be emptied by centrifugal force. So-called flow curves, of rate of shear against stress, can therefore be plotted, and provide a most useful picture of the behaviour of polymer solutions, dispersions or melts. The ratio of shear stress to rate of shear for a particular shear is known as the apparent viscosity.

A more complex instrument, of similar pattern, which is often called a rheogoniometer, also measures the force generated normal to the cone by viscoelastic liquids. Fortunately, these forces are not significant for most print pastes.

7.7.3 Non-Newtonian flow

From the flow curves thus obtained, it is found that the behaviour of viscous liquids can be classified into five categories, shown diagrammatically in Figure 7.7. A few materials, such as gum arabic pastes, poly(vinyl alcohol) solutions, and silicone oils, are essentially Newtonian (curve A in Figure 7.7), with viscosity independent of shear. Most print pastes show shear-thinning properties (B), with a significant reduction in apparent viscosity as the shearing stress is increased. The change is reversible, the viscosity increasing immediately shearing is reduced. A significant number of pastes do not flow at all until the shear stress exceeds a minimum value, known as the yield value (curve C in Figure 7.7). Beyond this value, they may show either linear or nonlinear flow properties. The former have been called Bingham systems, after E C Bingham, who defined the term 'plastic viscosity' as the ratio (shear stress – yield value):rate of shear. The concept of plastic viscosity has been extended to shear-thinning print



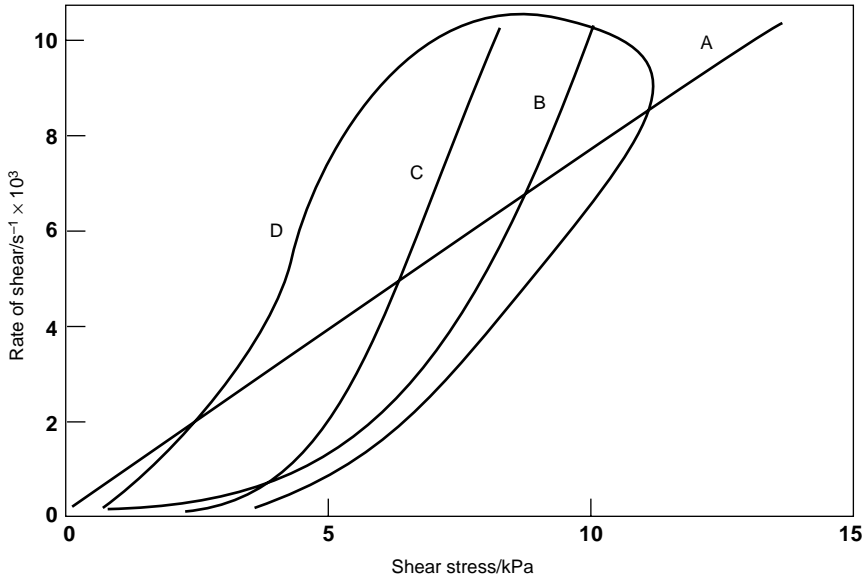

Figure 7.7 Typical flow curves demonstrating behaviour of viscous liquids

pastes, with flow curves that approach linearity at high shear, by extrapolating the linear section of the curve back to the stress axis to define a yield value.

A fourth type of behaviour, found in pastes with high pigment concentrations, has been called dilatant, but is better described as ‘shear thickening’ to avoid the assumption that volume expansion necessarily occurs. This is the phenomenon seen on wet sand, when pressure causes particles to touch and the friction between particles prevents their movement into expanded spaces. Free liquid is drawn into these spaces, making the system look dry.

Finally, there is the phenomenon known as thixotropy, shown by gelatine solutions and bentonite suspensions, for example (curve D). In this case the measured values of viscosity depend on the duration of shear as well as on the rate of shear, and increased resistance to shear is observed after a long rest time than after shorter rest times (Figure 7.8). The probable explanation is that intermolecular bonds are broken by shear and slowly re-formed after shearing ceases.

The distinction between shear thinning and thixotropic behaviour is therefore clearly defined, although superficially they are similar and the term ‘thixotropic’ has sometimes been used to cover both categories. Shear thinning is believed to occur:

- when the liquid flow draws long polymer chains, initially randomly oriented, into closer alignment (as in fibre extrusion) and therefore they move more easily, relative to one another

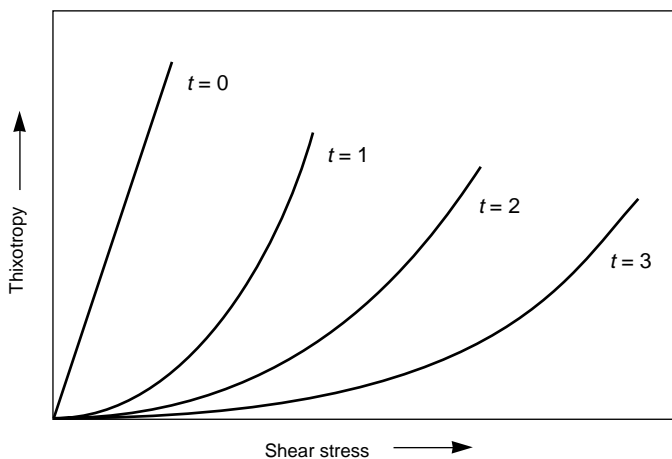

Figure 7.8 Flow curves for a thixotropic bentonite suspension immediately after agitation and after different setting times

- when large droplets, particles or solvated molecules, approximately spherical in shape, are deformed by shearing stresses to cigar-like shapes
- if the solvent sheaths held by polymer molecules are torn away by shearing forces and the dimensions of the packaged molecules therefore reduced.

If the molecules in a thixotropic paste are able to form intermolecular bonds very rapidly, however, the behaviour may resemble shear thinning because viscosity measurements cannot be made instantaneously. Muller has reported changes in apparent viscosity of synthetic thickenings, at a low, constant rate of shear, occurring over a period of 0.5 s [21]. Using sophisticated instrumentation, it is now possible to measure differences in the rate of recovery of viscosity, after the shear occurring in the printing operation, which could result in significant differences in print quality. It is necessary to study the changes occurring over times as short as 0.01 s.

The amount of data available on the rheology of printing pastes is limited and its interpretation is difficult. The collection of data, and correlation with printing results, could be very worthwhile. The importance of the difference between pastes with good 'flow' and those with a yield value is recognised by the practical printer. Pastes that do not flow under gravity from a paddle or stirrer, remaining on the paddle or falling off in lumps, are described as 'short'. This type of paste shows a yield value on flow curves and may give sharp fine lines, but may not be suitable for blotch printing.

Specific examples of the flow properties of thickeners are shown in Figure 7.9, which shows the substantial shear thinning of a poly(acrylic acid) (Carbopol) paste.



The significance of the r.m.m. of the polymer is seen in Figure 7.3, which shows the shear-thinning effect of orientation on a long-chain alginate. The shorter-chain alginate shows almost Newtonian behaviour, unless the concentration is high. The effect of molecular interaction is seen in the much higher viscosity, at low shear, of the paste containing unsequestered calcium ions. Clearly, high shearing stresses can overcome the bonding forces and separate, then orient, the polymer chains.

The concentration of thickening agent often has a significant effect on the character of the paste flow, more energy being required to separate and untangle the polymer chains in the more concentrated solutions. Figure 7.10 shows the effect of increasing concentration in the case of locust bean gum pastes.

Additions of dyes and auxiliaries may, of course, change the rheology of a paste. Jullander has reported increases in apparent viscosity of cellulose ether pastes on addition of three direct dyes [22]. The extent of molecular interaction was related to the amount of van der Waals bond formation expected. Kassenbeck and Neukirchner were unable to detect viscosity differences between alginate pastes containing CI Reactive Blue 99 and CI Reactive Orange 12, but differences in jet-flow properties of the pastes appeared to be related to the spread that occurred in rotary-screen printing [23].

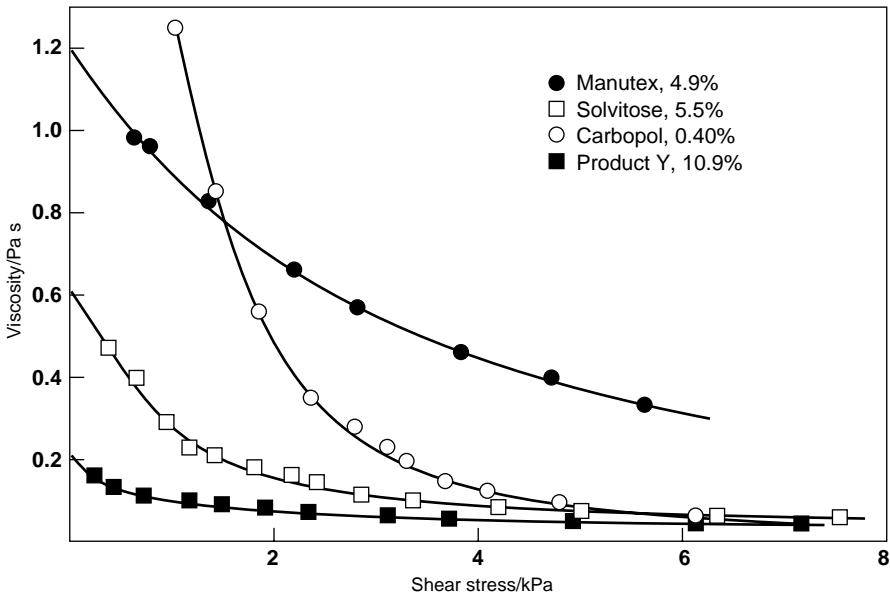

Figure 7.9 Thixotropic behaviour in pastes, increased resistance to shear being exhibited after longer rest times

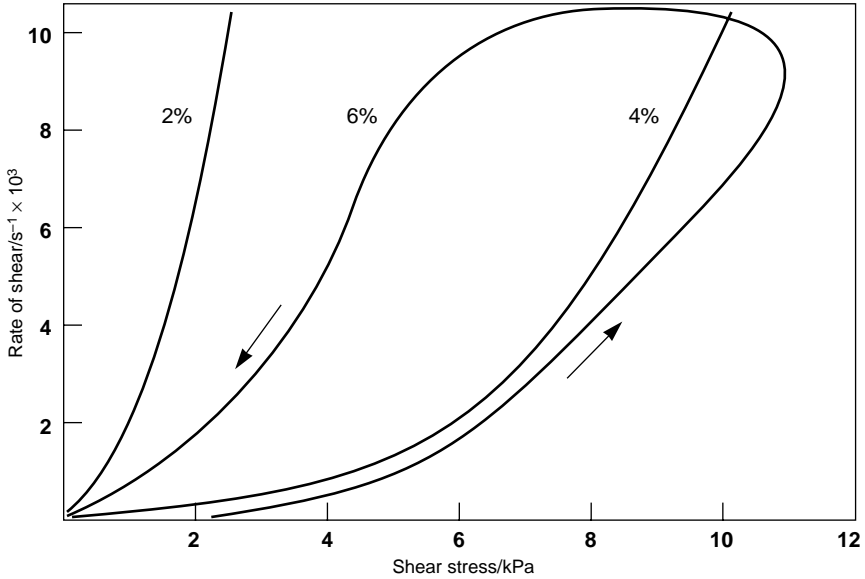

Figure 7.10 Effect of concentration on the flow of locust bean gum pastes

7.7.4 Paste flow in engraved-roller printing

For all printing processes, it is necessary to know what factors control:

- the volume of paste applied
- the penetration
- the spread,

as these are the parameters that together determine the sharpness of mark and the levelness of the print.

The print paste viscosity is obviously the major factor but, as the viscosity changes under changing shearing stresses, we need to know what stresses are applied during the printing process. No single measurement of viscosity, or concentration of thickening agent, will serve to characterise a paste or predict its behaviour in all respects.

Higginbotham was the first to analyse the relationship between printing behaviour and the effects of shear [24]. He argued that it should be possible to use the extent of spread as a measure of print paste viscosity at the moment of printing. Specifically, if three pastes made from different thickeners gave the same spread, then they must have had the same viscosity. The assumptions were:

- that pressure on the printing roller forced the fabric into the paste-filled engraving and the paste was therefore sheared as it moved through the capillaries of the fabric structure
- that the volume of paste applied did not change when a paste of different viscosity was used
- that spread occurred only in the short time of pressure application
- that if this time were constant, then the distance travelled along the capillaries (the spread) was a measure of viscosity.

Smooth curves were obtained when measured spread values of printed lines were plotted against concentration of thickening agent, for tragacanth, Nafka crystal and arabic gums (Figure 7.11). The concentration of each gum that would give a selected value of spread was therefore found. A cone-and-plate viscometer was used to obtain the apparent viscosity of the three pastes over a range of shear stress. Figure 7.12 shows the curves for pastes giving a spread of 0.02 cm when printed as stripes on a cotton poplin fabric. The curves intersect at a point corresponding to a shear stress of 400 N m^{-2} ($4000 \text{ dyne cm}^{-2}$).

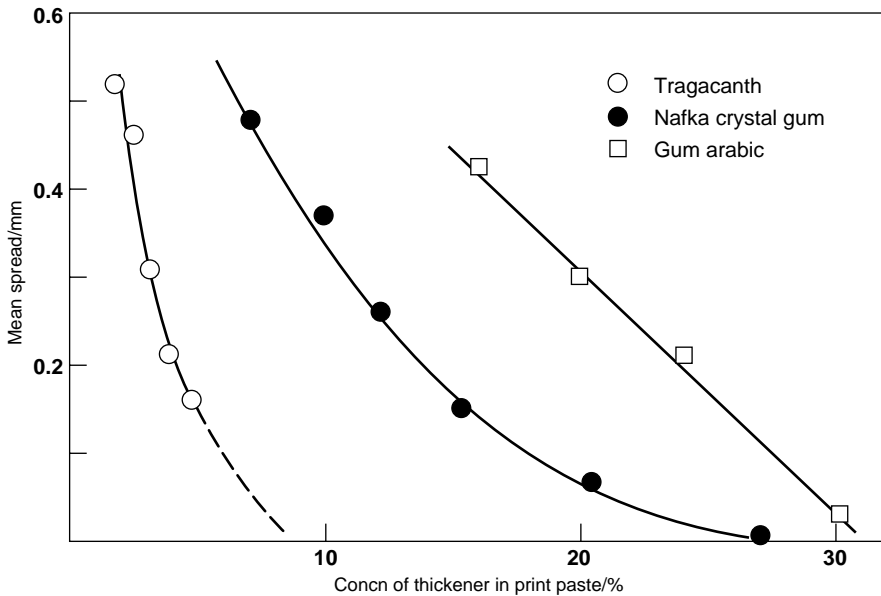

Figure 7.11 Spread of printed stripe at different concentrations of three thickeners

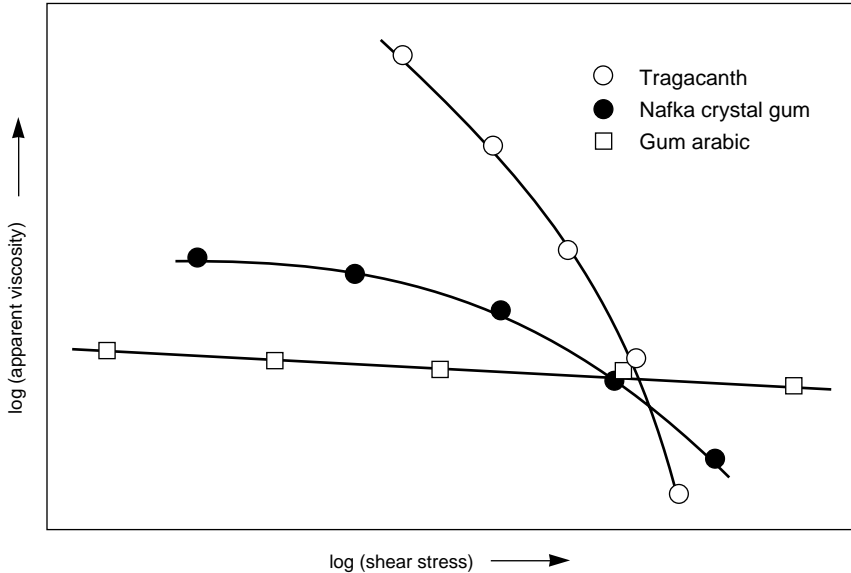

Figure 7.12 Viscosity as a function of shear stress for pastes giving equal spread

Similar values were obtained when the exercise was repeated for spread values of 0.04 and 0.005 cm, and the mean value of shear stress was found to be 450 N m^{-2} . Measurement of viscosity at this shear stress was therefore recommended, to predict the level of spread to be expected.

Subsequently, however, when the experiment was repeated using different thickeners, no correlation between spread and viscosity was observed [3]. Cheslett [1] also failed to obtain the expected intersection of rheograms when printing on polyester. The explanation in both cases was that the volume of paste transferred from engraving to fabric was significantly reduced when viscosity was increased. The results that Higginbotham obtained were probably valid for his conditions, but his assumption that the volume of paste applied was a constant is not generally valid.

It has long been known that the sharpness of the printed mark is improved by printing at high speed. This is clearly because less paste is transferred in the shorter contact time. By using the Washburn equation for liquid movement in a capillary, it can be shown that the transfer, penetration and spread of print paste could be due primarily to capillary forces. The value of the forces is certainly large enough to produce a substantial fall in the viscosity of shear-thinning pastes. The pressure that must be applied to the printing roller may also shear the paste as the fabric is forced into the paste, but may only be required to bring the paste into contact with the fabric capillary surfaces.

Sometimes, especially when a blotch has been printed, paste is visible on the fabric surface and is not uniformly distributed. Some of this paste is removed on the following roller (part of the crushing effect) and an improvement in levelness observed. Paste on the fabric surface adheres to the engraved roller as well as to the fabric and, as the roller continues its rotation, is stretched. Stretching produces ‘fibrillation’ of the paste (Figure 7.13); then the threads of paste break and collapse into small mounds of paste on the fabric surface. Higginbotham observed that his single-colour prints were only smooth if the viscosity at low shear (10 N m^{-2}) was below 3 Pa s , so that flow and levelling occurred.

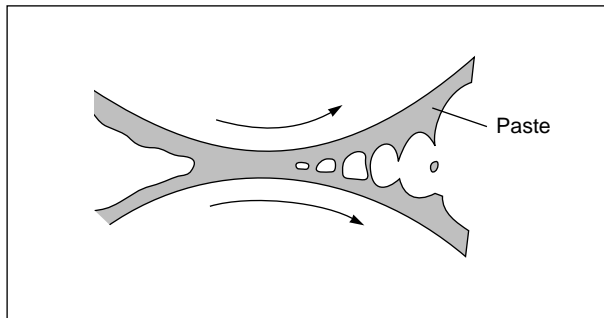

Figure 7.13 Fibrillation of paste between separating surfaces

Schmidt [25] and Kassenbeck [26] have examined the thread-forming properties of print pastes, and it has been suggested that the tack values, measured by paper printers, are probably related to this phenomenon. It is not yet clear, however, what is the best measure of this property or how it can be correlated with printing behaviour.

Summing up, it is clear that the viscosity of a print paste is usually changed by shearing forces, both under the doctor blade and as it enters the fabric. When the paste viscosity has been reduced and good contact with the fabric established, capillarity forces are probably dominant. The time available will often be too short to empty the engraving, however, and the paste between the fabric surface and the roller surface is split between the separating surfaces. This splitting occurs with the production of threads of paste that break and leave a non-uniform deposit on the fabric surface, resulting in a ‘mealy’ appearance of the print. This phenomenon is a greater problem for the paper printer, who uses a measurement of tackiness to control his ink formulation.

7.7.5 Paste flow in screen printing

Dowds has pointed out that the printer is usually left to manipulate the viscosity, squeegee setting and printing speed to obtain a satisfactory print, because there is no complete analysis of the screen-printing process [27]. He made a useful contribution himself, by reporting the volumes of paste applied under specified conditions, showing that this volume may be increased by a factor of five by reducing the squeegee angle. Japanese workers took Dowds' approach further and found that the volume applied can be related, at constant printing speed, to squeegee angle and size of the pressure zone by Eqn 7.2 [28]:

$$V = KB^{0.4} \cos A^{1.6} + C \quad 7.2$$

where B is the base length of the squeegee, A is the squeegee angle and K and C are constants.

In early work at UMIST, the volume applied was related to the dimensions of the screen mesh fabric, and the flow rates of pastes, flowing through the mesh under constant pressures, were measured [29]. Boyacigiller was the first to report measurements of the pressure profiles under squeegee blades, using apparatus in which the mesh fabrics were moved under fixed squeegees, as in a rotary screen [30]. Glastra [31] and Cropper [32] were later to confirm that the pressure profiles were consistent with the theory developed by Fuller to describe the pressures in hydraulic bearings [33].

Several workers have attempted to relate the volume of paste applied to the printing variables. The most recent [34] uses a multifactor regression analysis to solve a polynomial equation shown to relate the volume applied by a rotary screen to four variables: speed, load on squeegee, level of paste and viscosity at 1312 s^{-1} , when the mesh, squeegee type and substrate were held constant. Application of this approach can lead to the specification of squeegee load required to reproduce a given volume applied. Guion has shown that pastes giving prints of similar sharpness have the same viscosity at a shear rate of 20 s^{-1} [35].

The essential basis for an understanding of the process is therefore available. Whatever the squeegee type, whether moving or stationary, hard or flexible blade or rotating rod, paste is collected under the squeegee and pressure is developed because the paste cannot escape, except through the open holes of the screen mesh. The higher the speed and viscosity and the smaller the squeegee angle, the higher is the pressure that is developed. The time of pressure application is, of course, shorter at higher speed and also shorter for hard vertical squeegees than for flexible or large-diameter squeegees, forming a small angle with the screen.

The pressure developed under the squeegee may be just sufficient to fill the screen



pores and force the paste into contact with the substrate. Capillarity forces will then draw some of the paste from the screen pores into the fabric. The volume applied under such conditions may be less than the volume filling the mesh of screen pores. If the mesh is large, the viscosity low and a large, high-pressure zone squeegee is used, however, much more than one volume of the screen pores is applied (if the substrate is able to absorb such a volume).

The evidence is that the first stage of each printing cycle is the filling of the screen pores. Some pressure is required for this to happen and, on some automatic flat-bed machines, a flood stroke of the squeegee can be used, while the screen is suspended, to do this. A longer time is then available in the actual printing stroke for paste to be forced through the mesh. The time of pressure application in the flood stroke operation must be short (perhaps 0.01 s) because premature passage of paste through the screen does not occur. If it did, it would cause smudging. The continuous application of small pressures does produce flow, even through fine-mesh screens [24].

The second stage of the cycle occurs when the substrate is brought into close contact with the underside of the paste-filled screen. A small rise in pressure, overcoming the forces of surface tension, brings paste into contact with the substrate and, if the viscosity of the paste is low enough (having been sheared), it moves rapidly into the capillaries of the substrate.

The capillarity forces can be calculated for any particular situation. A fine-mesh nylon screen (186 mesh) with pores of 40 μm radius (r_1) would lose liquid to a cotton fabric substrate with interfibre capillaries of 15 μm mean radius (r_2) as a result of the net capillary pressure P given by Eqn 7.3:

$$P = 2\gamma \left(\frac{1}{r_2} - \frac{1}{r_1} \right) = 10(0.6 - 0.25) \times 10^3 = 3.5 \times 10^3 \text{ N m}^{-2} \quad 7.3$$

where γ is the surface tension of the liquid. The effective force would be greater during the short time during which the pressure under the squeegee was higher than the capillary pressure of the liquid in the screen pores.

The Washburn equation can be used to find the distance that the paste would move into the fabric capillaries, within the time available. If the squeegee pressure zone was 5 mm across and the printing speed 60 m min^{-1} , the time available would be 5×10^{-3} s. Paste of viscosity 0.1 Pa s would move 0.12 mm into capillaries of 15 μm radius, and this would be sufficient to empty the screen pores if there were at least 10 interfibre capillaries for each screen pore.

When paper of low absorbency is screen-printed, it is commonly observed that the paper is darker in areas between, rather than under, the screen holes. This must also be a result of capillarity forces, drawing paste into the smaller spaces.



After transfer to the substrate, spread into the substrate will continue until absorption of water raises the viscosity to a level at which spread is very slow. In the case of some low-solids-content pastes, water may be drawn into capillaries more strongly than it is held by the thickening polymer, with excessive spread of dye.

The final stage of the process starts when separation of screen and substrate causes extension and splitting of the paste. Schmidt was the first to measure the length of thread that can be drawn from print pastes under standard conditions [25]. More recently, Kassenbeck and Neukirchner have examined the dimensions of jets of moving paste to compare the tack of different print pastes [26]. No clear understanding of the phenomena, or correlation with printing behaviour, has yet emerged.

7.8 PRINT PASTE PRODUCTION

The preparation of print pastes requires great care, and the attention to reproducibility of quantities and conditions. Printers usually prepare thickener pastes in advance of actual requirements, in order to allow cooling, escape of trapped air and completion of swelling. The colorants and chemicals are then added to these pastes later. Now that easily dispersed thickening agents are more readily available, some printers have adopted the very different approach of making up a final print paste in a single operation, directly from raw materials. This would not usually be economical in labour for the larger printing units, and the risk of having printing machines waiting for pastes would be increased.

As already indicated (section 7.2.4), the selection of thickening agent may be determined by its ease of dispersion and the equipment available. Natural gums require pre-swelling and, like starches, boiling in a double-walled heating pan with constant stirring. Powerful, slow-moving stirrers are used, which ensure thorough mixing without dragging air into the viscous paste. Where large quantities of starch pastes are required, they can also be produced in continuous-action vortex-type blending and heating units.

The thickener thus produced is likely to contain a few lumps of imperfectly dispersed thickening agent and insoluble impurities that must be removed before printing. It is good practice to strain the thickener before addition of dye. This can be done by pumping it through a set of wire mesh sieves, of increasing fineness, during transfer from boiling pan to storage tank.

A typical procedure for the preparation of thickener from gum tragacanth, in flake form, illustrates the extreme requirements of time and attention. The solid flake (70 parts) is stirred with 1000 parts of cold water and allowed to swell for 1–3 days, with occasional stirring. The mixture is then raised to the boil, in a jacketed and stirred pan, and held at the boil until solution is obtained (at least 5 h). After cooling, the paste is bulked to 1000 parts and strained.

The readily dispersed thickening agents, for example, starch and locust bean gum



ethers and the alginates, can be simply sprinkled into cold water, with dispersion assisted by high-speed stirring. The stirrer must be of a size and design that moves the whole mass quickly enough to disperse aggregates before significant swelling occurs. Addition of the dry thickening agent should be at a rapid but controlled rate, so that lumps will break down almost immediately. An hour or more is required for swelling to occur and maximum viscosity to be attained.

When the thickening agent swells very rapidly, it can be difficult to avoid the formation of lumps unless special techniques are used to obtain dispersion. This is the case for synthetic thickening agents, which are therefore often purchased as liquid concentrates. The essential step in the preparation of such a concentrate is the initial dispersion of solid powder in a nonswelling liquid. For example, a poly(acrylic acid) (15 parts) can be stirred into white spirit (30 parts) containing a dissolved water-in-oil emulsifier (5 parts of sorbitan mono-oleate). Water, containing the alkali to neutralise the poly(acrylic acid), is then added steadily, with stirring. Finally, the total amount is made up to 100 parts with a hydrophilic surfactant (4 parts, nonionic type, HLB about 15), which ensures rapid wetting when the 15% concentrate is diluted to approximately 1% in the print paste. This encapsulation of thickening agent within a hydrophobic coating produces a low-viscosity concentrate that is easy to handle and already contains the alkali required to produce the full viscosity; only dilution is required to increase the viscosity.

A stock oil-in-water emulsion thickener is readily made, using a high-speed stirrer to disperse 800 parts by mass of white spirit into 190 parts of water containing 10 parts of emulsifier.

From weighed quantities of a stock thickener, print pastes are made by stirring in the required auxiliaries and colorants, as solution, dispersion or solid, according to the amount of water required and the solubility of the materials added. Reactive dyes can be sprinkled into the thickener, with high-speed stirring, provided that their physical form and solubility are suitable and time can be allowed for dissolution to take place.

7.9 COLOUR SHOP ORGANISATION

In order to obtain maximum efficiency in the colour shop, it is usual to pre-prepare standard colour pastes. Provided that the pastes have adequate stability they can be prepared in large quantities and stored in containers equipped with large-bore taps. Print pastes may then be made up quickly and conveniently by weighing the required amounts of pastes into tared tubs on a balance that moves on a rail track between the stock containers. This final stage can be automated for maximum speed and reproducibility. It is good practice at this stage to strain the paste through a fine-mesh sieve into a clean tub within an evacuated chamber.



The particular systems used are selected according to local requirements and tradition. For pastes of vat dyes, for example, it has been common practice to make concentrated standard pastes and a standard 'reduction' paste, with which to reduce the dye concentration. A range of concentrations can be obtained by mixing in ratios of 1:2, 1:3 and so on, known as 'reductions'. Traditionally, pastes were measured out and mixed by volume but, provided reliable balances are available, it is now more convenient to measure by mass.

REFERENCES

1. A B Cheslett, MSc thesis, UMIST (1981).
2. D A Reilly and H A Turner, *J.S.D.C.*, **67** (1951) 103.
3. M Glastra and F L J van Lamoen, *Melliand Textilber.*, **46** (1965) 1339.
4. H S Frank and W Y Wen, *Disc. Faraday Soc.*, **24** (1963) 2513.
5. R M Diamond, *J. Phys. Chem.*, **67** (1963) 2513.
6. *Industrial gums*, 2nd Edn, Ed. R L Whistler (London: Academic Press, 1973).
7. J Zonnenberg, *J.S.D.C.*, **66** (1950) 132.
8. T L Dawson, *J.S.D.C.*, **75** (1959) 413.
9. N Bigler, *Ciba-Geigy Rev.* (1971–7).
10. C A Kumius, USP 2 971 458 (1961).
11. T F Cooke, *Text. Chem. Colorist*, **15** (1983) 74.
12. T L Dawson, *J.S.D.C.*, **97** (1981) 262.
13. R Koch, *Melliand Textilber.*, **66** (1985) 812.
14. B N Bandyopadhyay, *Text. Dyer Printer*, **13** (8) (1980) 35.
15. C J Verbrugge, *J. Appl. Polymer Sci.*, **14** (1970) 897.
16. W Berlenbach, *Melliand Textilber.*, **53** (1972) 207.
17. D W Hughes, *J.S.D.C.*, **95** (1979) 382.
18. R Seddon, *Amer. Dyestuffs Rep.*, **74** (2) (1985) 13.
19. R Hofstetter and G Robert, *Dyer*, **162** (1979) 225.
20. J R von Wazer, *Viscosity and flow measurement* (London: Interscience, 1963).
21. R Muller, *Melliand Textilber.*, **53** (1972) 201.
22. I Jullander, *Ind. Eng. Chem.*, **49** (1957) 364.
23. P Kassenbeck and A Neukirchner, *Melliand Textilber.*, **61** (1980) 522.
24. R L Derry and R S Higginbotham, *J.S.D.C.*, **69** (1953) 569.
25. K Schmidt, *Melliand Textilber.*, **35** (1954) 177.
26. P Kassenbeck et al., *Melliand Textilber.*, **61** (1980) 349.
27. B F Dowds, *J.S.D.C.*, **86** (1970) 512.
28. K Teraji and T Hiro, *Sen-i Gakkaishi*, **33** (1977) 102.
29. M A Salam, MSc thesis, UMIST (1966).
30. G Boyacigiller, PhD thesis, UMIST (1970).
31. A G M Tak and M Glastra, *Textilveredlung*, **7** (1972) 780.
32. M Cropper, PhD thesis, CNA A, Watford (1973).
33. D D Fuller, *Theory and practice of lubrication for engineers* (New York: John Wiley, 1956).
34. I Hardalov, K Velev and S Gluharov, *J. Text. Inst.*, **83** (3) (1992) 449.
35. T H Guion and J R Hood, *Text. Res. J.*, **55** (1985) 498.



Fixation and aftertreatment processes

Leslie W C Miles

8.1 INTRODUCTION

If a typical textile print is washed soon after printing and drying, a substantial part of the colour is removed. An appropriate fixation step is therefore necessary. Complete fixation can rarely be achieved, however, and the removal of unfixated dye, thickening and auxiliary chemicals in a subsequent washing process is usually required.

The efficiency with which these processes of fixation and washing are carried out is vitally important, to both the quality and the cost of the prints. The proportion of faults in the final product that are introduced at this stage can be disastrously high. The objective of this chapter is to direct attention to the details of the processes and the understanding of their mechanisms.

8.2 PIGMENT PRINTS

When water-soluble dyes are used the necessity for fixation is obvious enough, but even the ubiquitous, simple pigment print shows poor fastness to washing if the fixation process is skimmed or omitted.

Since the pigments used contain significant amounts of dispersing agent, and since the polymeric binder is also a dispersion with its own dispersing agent, the printed deposit is readily redispersed in water after a short drying process (see section 5.2.2). Only when the printed fabric has been raised to an adequate temperature is the binder given enough energy to form a continuous film that incorporates the pigment particles and adheres satisfactorily to the fibre surfaces. At the same time, crosslinking of the binder molecules is completed if appropriate monomers or agents have been incorporated, and the required pH and temperature achieved.

It is possible to use any controllable means of raising the fabric temperature: convection in hot air, conduction on cylinders, radiation or steaming; the first of these is most commonly used. The conventional roller baker or 'curing' oven (Figure 8.1) is



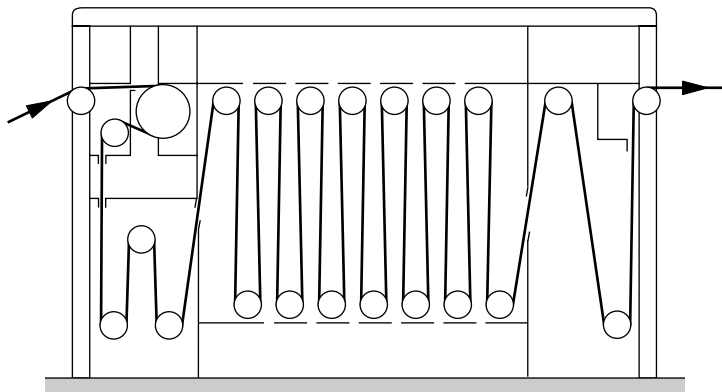

Figure 8.1 Roller baker unit (Mather and Platt)

an arrangement for carrying woven fabrics through recirculated hot air, with as many fabric transport rollers as are required to provide the exposure time and fabric speed desired. Shorter times are required at high temperatures, but the risks of discoloration or inadequate treatment are greater. Times of 3–5 min at temperatures in the range 140–160 °C have been generally preferred.

The rate of heat transfer in baking is low and times of 20–60 s are required to bring the fabric to a temperature close to that of the air. Treatment times of 2 min or less, therefore, allow little latitude, and any variation in moisture content of the entering fabric can lead to significant differences in the fixation. Thus when drying and fixation are to be carried out in a single unit, control of the conditions is critical. Such a single-stage process appears attractive, but is likely to use more energy than a two-stage process because the large volume of fresh air required for drying and not required for baking will be unnecessarily heated, unless humidity control is practised (limiting fresh air inlet).

Fabrics that cannot be handled on such machines include almost all knitted fabrics. These may be fixed in festoon-type machines or on Fleissner-type perforated drum machines, brattice conveyers or stenters.

8.3 STEAMERS

Printed dyes are usually fixed by steaming processes, the steam providing the moisture and rapid heating that brings about the transfer of dye molecules from the thickener film to the fibre within a reasonable time.

Historically, the process of developing printed mordants was known as ‘ageing’ and took a long time, as the term implies. Printed fabric was draped over poles and left in a

room with a warm and humid atmosphere for some days, allowing the processes of diffusion and chemical reaction to occur. The term has been retained in use for steaming treatments, especially for short processes and machines; it has given rise to the descriptive, and euphonious, terms 'rapid ager' and 'flash ageing'. Some authors have attempted to distinguish between steaming and ageing (with steam). This can lead to confusion, so the two terms can be used interchangeably.

The time and conditions for fixation in steam vary with the properties of the dyes and fibres used, ranging from 10 s to 60 min in steam at 200 to 100 °C. Technical and economic factors have encouraged the use of higher temperatures and shorter times, and the change from batchwise to continuous processes. A constant feature in the design of all printing steamers, as distinct from steamers for other textile processes, is the need to prevent the marking-off of printed colour on to pale-coloured areas.

8.3.1 Batch steamers

For expensive fabrics and small quantities, there are obvious advantages in using low-capacity steamers that can be quickly raised to their working temperature and that produce no creasing, stretching or other damage to the fabric. Batch steamers also show advantages when colour yields are improved by steaming at above-atmospheric pressure or for extended times, as in the case of deep colours on polyester fabrics.

A successful design for such a steamer is shown in Figure 8.2; it is known as a star or bell steamer. Up to 500 m of fabric is attached by hand, along one selvedge, to the hooks on a star-shaped carrier frame, to form a spirally wound load with a space of about 1 cm between the fabric 'layers'. An interleaved back-grey is used to eliminate all risk of marking-off, as the weight of the fabric and the uniformity of winding are unlikely to be adequate to prevent adjacent layers from touching.

The steam chamber is a cylindrical pressure vessel, mounted vertically and closed at the top (hence likened to a bell) with a door that can be swung into position at its base. It is elevated because steam is lighter than air, so that with this arrangement the bell can remain filled with steam and either the star frame can be raised into the steam, or the bell lowered on to the star frame. Less air is taken in with the fabric, and the air is more easily displaced by steam, than in any other possible arrangement.

The steam supply should be air-free and, ideally, dry but saturated. If there is significant superheat in the steam, a humidifier is used to increase its relative humidity. Wet steam is undesirable because splashes and drops of water inevitably cause local bleeding of dye or auxiliary chemicals.

The older-style cottage steamers were often larger vessels into which the printed fabric on a carrier was wheeled horizontally. Substantial flow of steam is required to displace air from such a steamer.



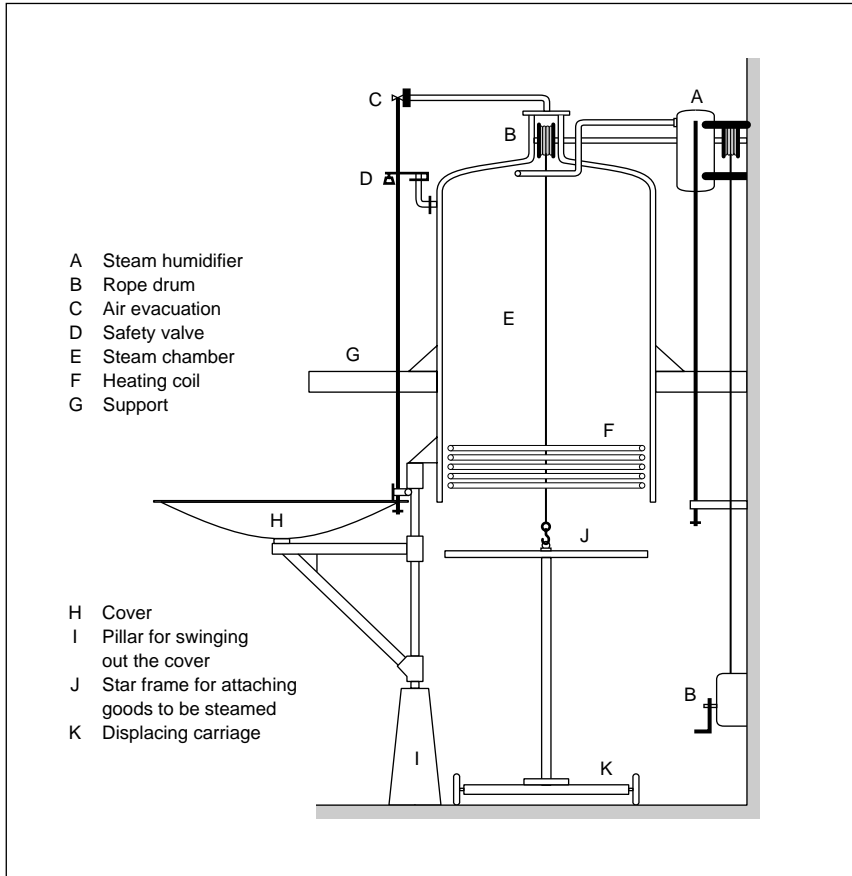

Figure 8.2 Section through a star steamer (Kerag); the loaded star is raised into the steam chamber

Times of at least 10 min are usually allowed for fixation in batch steamers in order to ensure optimum fixation and therefore keep the staining hazards in washing-off at a minimum. Saturated steam at 1.5–3 atmospheres pressure gives good colour yields on triacetate, acrylic and polyester fibre fabrics.

8.3.2 Continuous steamers

A logical development of the ageing of prints while looped on rods led to the continuous transport of printed fabric in festoon steamers (Figure 8.3). Long loops are formed on rods, touching only the unprinted face, which are moved slowly along a

track near the top of a large steam chamber, constructed in brick or steel. The rods may be slowly rotated to avoid bar marks due to non-uniform accessibility to steam. With loops (festoons) of up to 5 m in length, long steaming times or high throughput velocities can be achieved without the tension and mark-off problems associated with top and bottom carrying rollers. Several ingenious mechanisms for the formation of festoons of equal length are available. At the end of the steaming period, the fabric is withdrawn at the same high speed as at the entry point. A fabric content of 800 m allows an overall throughput speed of 80 m min^{-1} with a 10 min steaming time. Capacity can be doubled by introducing two layers of fabric, with an intermediate back-grey, if the printed area is not large. The larger the steamer dimensions and the more densely it is packed with fabric, the more difficult it will be to maintain uniform steaming conditions.

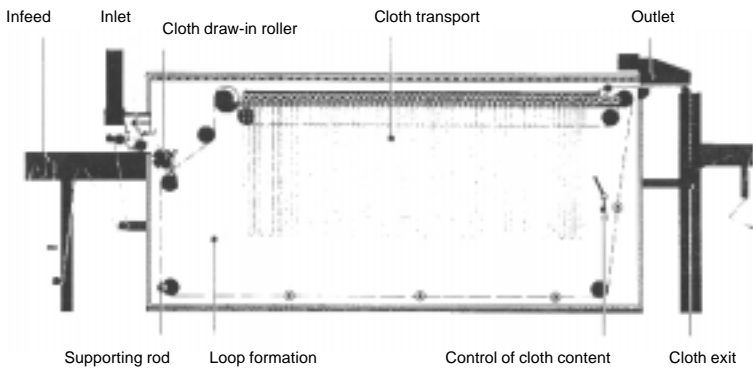

Figure 8.3 Festoon steamer (Stork)

It is now considered essential to have fan-assisted circulation of steam. In older designs a flow of steam through a water tank at the base, which reduces the superheat of injected steam, to exhaust ducts in the heated roof was used to help to maintain uniformity and provided a valuable cooling effect.

In most early festoon steamers, the fabric entry and exit were through slots in the roof, provided with heated roller seals. The seals could never be perfect and escaping steam, absorbed by the print, increased the mark-off from the printed surface to the sealing roller. A doctor blade was therefore required to clean the roller surface, before it again contacted the fabric. In modern equipment the fabric entry and exit ports are usually positioned in or near the base of the steam chamber, which reduces the sealing problem significantly (as steam is lighter than air).

Popular steamers made by Stork or Babcock have steam circulation arrangements whereby steam is extracted by fans from the base of the steamer, passed through heatable radiators, sprayed with water as needed, and forced through ducts to the top of the steamer, whence it passes down the folds to the bottom. In this way festoon steamers are increasingly being produced as universal steamers, so that any temperature between 100 and 200 °C may be employed. Since many knitted fabrics can be satisfactorily handled in festoon steamers, provided the loops are not too long, the term 'universal steamer' can in fact be justified.

Where the steaming time required is short (up to 2 min), more compact machines with fabric-carrying rollers have been used. The term 'Mather and Platt Roller Ager' was often applied to such steamers, in which the fabric path resembled that in a roller curing oven. With the increasingly important screen prints, which usually have more surface colour than engraved-roller prints, marking-off via the rollers became more probable. The Krostewitz steamer overcame this difficulty by adopting a spiral movement of fabric, using rollers that contacted only the back face of the print (Figure 8.4). At the centre of the spiral it is, of course, necessary to withdraw the fabric by rotating it into a normal plane so that it can be taken through a slot in the side wall. This is achieved by passage around a stationary sword bar (rod) at an angle of 45° to the fabric path. A double rotation of plane and a second, outward-moving, spiral allows fabric exit through the entry slot as in Figure 8.4.

Steamers of this type, with a fabric content of 60 m, are used to give 30 s steaming at speeds of 120 m min⁻¹, but are suitable only for stable, woven fabrics. Some of the carrying rollers must be driven, to prevent the build-up of high fabric tensions.

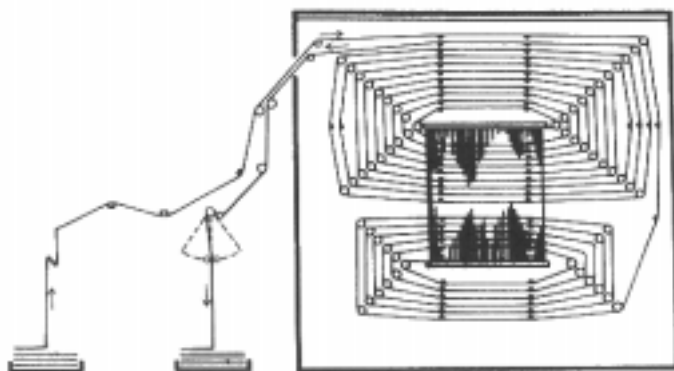

Figure 8.4 Double-spiral steamer (Krostewitz)

For steaming times of about 30 s, again without touching the print face until fixation is complete, an alternative fabric transport system has been used, where a compact arrangement is not essential. This is the rainbow or arch steamer (Figure 8.5).

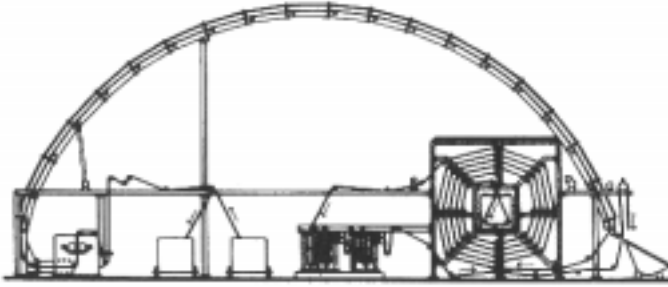

Figure 8.5 Arch steamer of 40 m capacity with prepadding and afterwashing facilities

An important application of either type of such flash agers has been in pad–steam (sometimes called two-phase) processes. Vat prints on cotton, for example, are efficiently fixed by application of alkali and reducing agent solution to the printed and dried fabric immediately before steaming. A thickener that gels on contact with alkali is required, and the time of contact between print and solution must be limited to avoid bleeding. The application of a minimum add-on of solution (about 30% on mass of fibre) using one of the ‘MA techniques’ can give higher visual colour yields than obtained by conventional padding [1]. In the case of prints obtained with reactive dyes, the advantage can be even greater [2].

For short steaming times at low running speeds, the simplest possible arrangement is a chimney or tower steamer, mounted above the pad mangle.

8.3.3 Mechanisms of fixation processes

Fox, in a stimulating review of dye-fixation processes, has pointed out that when buying and running process machines we must not forget that the fundamental requirement is the efficiency of the molecular processes [3]. This is a necessary reminder when considering the mechanism of steaming processes, where we find easily overlooked, but significant, molecular phenomena.

It is desirable, in the first place, to understand the properties of steam itself.

8.3.4 Steam: terms and properties

Water vapour at 100 °C and standard atmospheric pressure is known as saturated steam, and as dry saturated steam if it contains no droplets of liquid water. Steam at 100 °C is very rarely found in a printworks, however, and the differences are significant.

Boilers are designed to provide steam at pressures substantially above atmospheric pressure. This allows the use of smaller-diameter pipes to convey the substantial weights of water vapour from the boiler to the steamer and other steam-using machines.

Saturated steam at 35 kPa above atmospheric pressure (5 lbf in⁻² gauge pressure) occupies three times the volume of the same mass of steam at 350 kPa (50 lbf in⁻²). At pressures above atmospheric, water boils at a temperature above 100 °C, more heat is required to evaporate a given mass of water and the steam produced has a high temperature. The temperature of saturated steam at 350 kPa above atmospheric pressure is 148 °C. Any cooling would produce condensation, and this is why steam at a certain pressure, and a temperature corresponding to the boiling point of water at that pressure, is known as saturated steam. Table 8.1 shows the temperatures at which water boils, and hence at which steam is produced, for six pressures.

Saturated steam is often deliberately superheated in the boiler house, giving a gas which does not condense until it has given up its superheat. This ensures that steam pipes do not carry a significant volume of troublesome water. Superheat is also introduced when saturated steam is allowed to expand rapidly as it passes through a valve into a chamber at lower pressure. For example, steam at 700 kPa (100 lbf in⁻²) and 170 °C when allowed to expand at 70 kPa (10 lbf in⁻²) falls to 148 °C, but this is

Table 8.1 Temperatures of saturated steam

Pressure		
Absolute /kPa	Gauge /lbf in ⁻²	Temp. /°C
136	5	108
170	10	115
239	20	126
308	30	134
446	50	148
791	100	170



33 degC above the temperature of saturated steam at 70 kPa. The steam therefore has 33 degC of superheat.

If saturated steam is wet, carrying droplets of condensed water along in its flow, a reduction in pressure may provide enough superheat to re-evaporate the water. A water separator, containing baffle plates, will also help by removing the larger droplets.

If the steam in use contains undesirable superheat, its temperature can be reduced by bubbling it through water or injecting water as small droplets. Printers use superheated steam in high-temperature (HT) steamers. These always operate at atmospheric pressure, so that the steam is adequately described by its temperature, which is approximately the superheat plus 100 degC. The concept of relative humidity (RH) has also been applied, and has the advantage that the equilibrium moisture content of fibres can be correlated with the humidity of their surrounding atmosphere over a wide range of water vapour to air ratios and temperatures. The definition of RH is given in Eqn 8.1:

$$\text{relative humidity (\%)} = \frac{\text{vapour pressure}}{\text{saturation vapour pressure}} \times 100 \quad 8.1$$

which applies equally well to 100% vapour and to mixtures with air, because the saturation vapour pressure depends only on temperature.

The vapour pressure in HT steamers is 0.1 MPa (1 atm); at 150 °C, for example, the saturation vapour pressure is 0.5 MPa (5 atm), so that the RH is 20%. The RH must never be quoted without specifying the temperature.

8.3.5 Dye fixation in steam

Steam can be a convenient source of both water and heat as both are transferred rapidly and uniformly over the surface areas of printed fabric entering a steam chamber. As we have seen, however, steam may be wet or dry, saturated or superheated, and the conditions of use must be chosen and maintained.

The essential requirements in all print fixation processes using steam are:

- the pick-up of enough water to swell the thickener film, but not so much as to cause the print to spread
- dispersion and solution of the dye, and production of a liquid medium through which the dye can diffuse to the fibre surface
- absorption of water by fibres such as cotton, nylon and wool, which must be swollen to allow penetration of dye
- raising the temperature to a level that accelerates the processes of diffusion, especially into the fibre.



In some cases steam can satisfy all the requirements but, as in all coloration processes, auxiliary chemicals may be introduced to assist dye solution and diffusion, or to make the process less critically dependent on the maintenance of ideal conditions. In order to illustrate the phenomena that can occur during the steam fixation of prints, one of the most critical and best-studied processes is considered here in detail.

Vat dye prints (all-in process) on cotton

The insoluble vat dyes must be reduced to their soluble leuco forms, to allow diffusion into the fibre. A stabilised reducing agent, sodium formaldehyde sulphoxylate (CI Reducing Agent 2), is activated when the print temperature approaches 100 °C and reduction therefore occurs inside the steamer, the highly soluble potassium carbonate providing the required alkalinity. It has been shown that the vat dyes must be selected from those with aqueous leuco potentials smaller than -920 mV. A typical paste formulation is shown in Recipe 8.1; the print would be dried rapidly, cooled and then steamed for 8–20 min in air-free steam, before rinsing, oxidising, soaping and drying.

Recipe 8.1

Vat dye paste	7 g
Potassium carbonate	15 g
CI Reducing Agent 2	8 g
Glycerol	5 g
Thickener	24 g
Water	41 g
	100 g

The steaming stage was known to be critical [4], especially where the cover of the design was high. Difficulty was experienced in keeping the temperature of the steam below 103 °C, and dye fixation was reduced when the temperature rose above this level. The incorporation of glycerol in the print paste, to act as a humectant, improved the fixation. Thorough and rapid drying of the print was, however, found to be essential because the stability of the reducing agent in air under damp conditions was not satisfactory [4–6]. In practice, after thorough drying a cooling procedure was necessary.

In this discussion the steam conditions can be assumed to be ideal, that is, no droplets of liquid water are present, and that it has a temperature of 100 °C, with no superheat. When the dry print enters the steam, three exothermic reactions occur.



Firstly, steam will immediately condense on the cold fabric, giving up its latent heat of 2260 kJ kg^{-1} (539 cal g^{-1}), and raising the fabric temperature very quickly to 100°C . Cotton has a specific heat of $1.4 \text{ kJ kg}^{-1} \text{ K}^{-1}$ ($0.32 \text{ cal g}^{-1} \text{ per degC}$) and, starting at 20°C and 7% regain, 5.5 g of steam will condense as liquid water on 100 g of fibre.

As this water condenses more heat will be liberated, partly because of the heat of wetting of cellulose and partly because of the heat of solution of potassium carbonate. For mercerised cotton at 7.5% regain, the heat evolved (when fully wetted) is 25 kJ kg^{-1} (6 cal g^{-1}). Starting at 2.5% regain, the heat is 50 kJ kg^{-1} (12 cal g^{-1}), but at 13% regain it is only 8.5 kJ kg^{-1} (2 cal g^{-1}). As the absorption of condensed water and the consequent generation of heat occur less rapidly than the condensation of steam, the fibre temperature rises above 100°C by an amount that depends on the initial regain and on the cooling effect of the steam. Fell and Postle have recorded temperatures of 110 and 120°C on cotton and wool respectively after absorption of steam at 100°C [7].

Fahnoe measured cotton fabric temperatures in a laboratory steamer for three initial moisture contents (Figure 8.6) [5]. The temperature rise that occurs has been turned to advantage by running dry back-greys through steamers to shorten the warming-up period. The initially cold steamer produces a lot of condensed water, which can be partly absorbed and partly evaporated by the heat generated in the cotton back-grey. The damp back-greys are then suitable for running later, with prints, when the steam temperature has to be kept down.

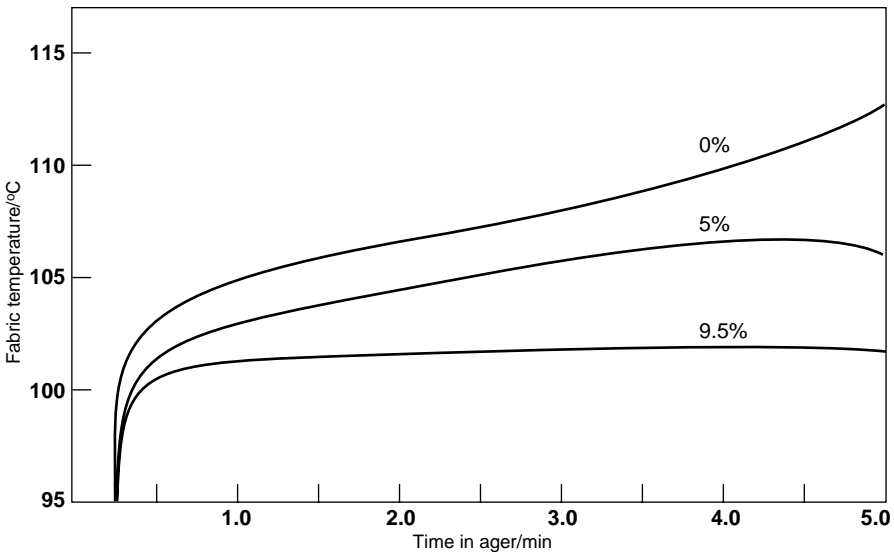
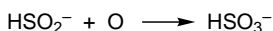

Figure 8.6 Measured temperatures of cotton fabric of 0, 5 and 9.5% initial moisture content within an ager (steam temperature 100°C)

Similarly, anhydrous potassium carbonate has a heat of solution of 27.6 kJ mol^{-1} ($6600 \text{ cal mol}^{-1}$), and the amount used in the print paste could provide up to 25 kJ kg^{-1} (6 cal g^{-1}) fibre.

The third reaction is the oxidation of active reducing agent (sulphoxylate ion) (Scheme 8.1), which is strongly exothermic ($+560 \text{ kJ mol}^{-1}$).

Scheme 8.1

The air content of the steam should be kept low (less than 0.3%), but the required reduction of vat dye means the equivalent oxidation of sulphoxylate will occur and the production of heat is inevitable [8]. If only 20% of the total sulphoxylate were oxidised in the early stages of the steaming process, about 50 kJ kg^{-1} (12 cal g^{-1}) of dry fibre would be liberated.

It is clear, therefore, that a total heat input of about 85 kJ kg^{-1} (20 cal g^{-1}), over and above the heat of condensation, is likely for a fabric of low moisture content and for 100% print cover. This could lead to a fabric temperature of 140°C , but actual temperatures will not be so high because the exothermic reactions occur slowly and evaporation from the print and cooling by the surrounding steam also occur. Fabric temperatures of 115°C have been recorded (Figure 8.7).

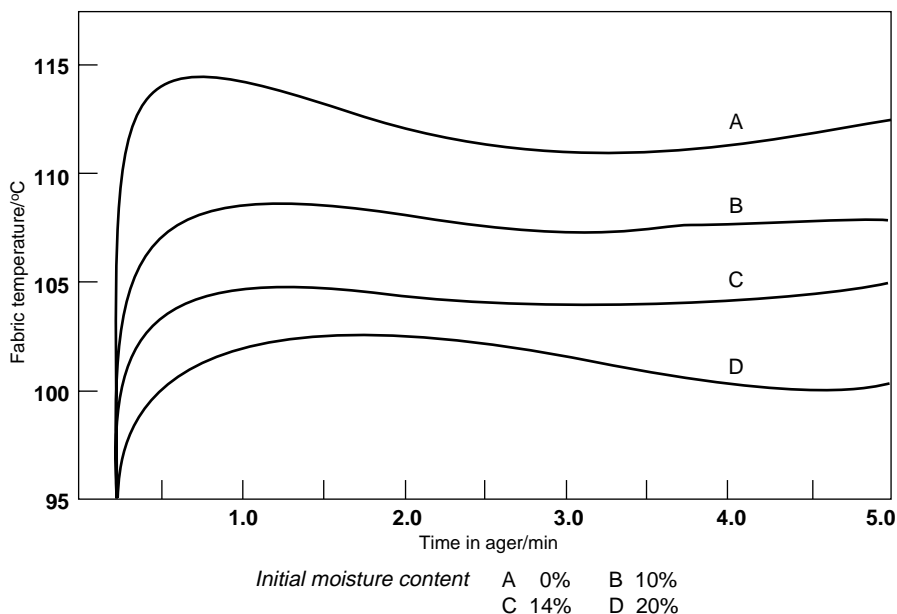

Figure 8.7 Variation of vat print temperature within an ager

Meggy has shown that the boiling point of the print paste (a concentrated solution) is about 130 °C, so that a substantial rise above 100 °C is possible before the cooling due to evaporation balances the heat input [9].

The changes occurring in steaming can be illustrated by a heat content/moisture content diagram (Figure 8.8). This reveals the importance of the initial regain of the fabric. At only 2.5% moisture content, the maximum heat is generated and the fabric loses water by evaporation, the moisture content falling to a level that is inadequate for complete reduction and diffusion of the dye. At 7% initial moisture content, less heat is generated by wetting and the cooling due to evaporation limits the temperature rise in extent and time. Moreover, the lower temperature of fabric and surrounding steam allow the absorption of more water vapour. During the time allowed for steaming, therefore, the dye fixation is higher in the latter case.

It may now be recognised that the printed and dried fabric, with a regain of perhaps 2.5%, is cooled in order to allow a rise in moisture content (from the atmosphere). One printer found that when printed fabric was taken through a slot in the floor and run over rollers close to the river below, colour yields were consistently good. Adding

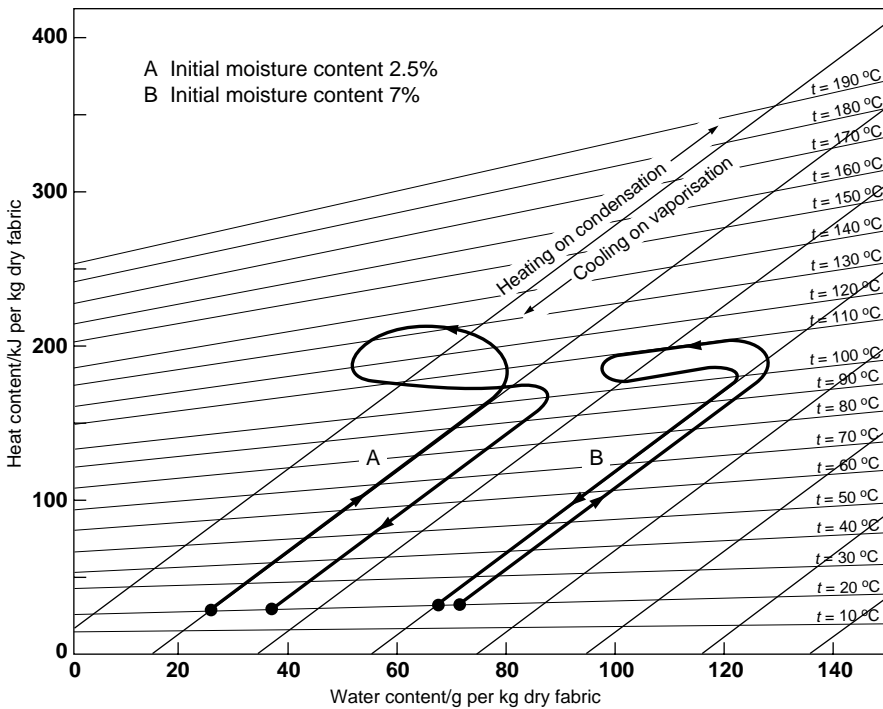

Figure 8.8 Heat content/moisture content for the steaming of vat dye prints on cotton (fabric temperatures shown on the right)

water by spraying is a possible approach, but one that is difficult to control. The rate of flow of steam through the steamer is the other important parameter. Fahnoe found that a flow rate of three steamer volumes per minute was sufficient to prevent the fabric temperature rise to 115 °C that occurred at 0.5 volumes per minute. Such a high-rate flow of steam is of course expensive and the provision of a cooling and recirculation arrangement, possibly with injection of water, reduces operating costs.

Finally, the effects of superheat must be taken into account. Steam at 104 °C and at atmospheric pressure has a relative humidity of 85%, and the equilibrium sorption of water vapour by cotton is substantially reduced at humidities below 100% (Figure 8.9). As the operating steam temperature in vat print steamers often approaches 104 °C, and therefore the moisture content of pure cotton cannot exceed 9–10%, it is not surprising that difficulty is experienced in obtaining reproducible results.

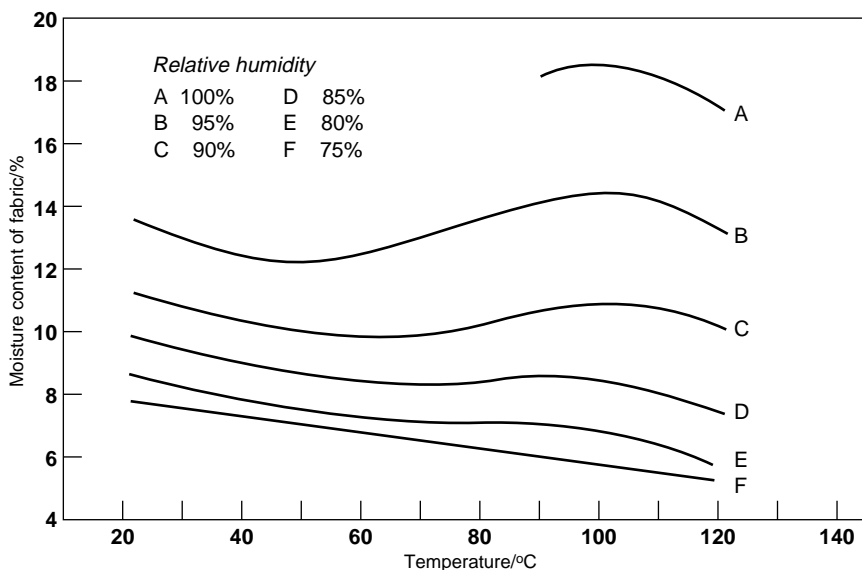

Figure 8.9 Equilibrium sorption of water by cotton [10]

The practical answer to the problem was the addition of glycerol and the use of the deliquescent potassium carbonate, rather than the cheaper sodium carbonate. Water absorption by the print paste is therefore substantially higher than by the cotton fibre, especially under adverse steam conditions. Some of the glycerol and carbonate will have entered the fibre, thereby increasing fibre swelling. Measurements of water content during steaming showed that a typical vat print paste film absorbed about 20% of water after 2 min and 30% after 10 min, under ideal steam conditions.



The steaming of any other class of printed fabric is less complex, but may involve one or more of the interactions of physical and chemical factors discussed above. For example, nylon is very sensitive to superheat in the steam (which can arise from the heat of wetting of the fibre), lower colour yields being the consequence.

8.3.6 High-temperature steaming

In some circumstances the use of superheated steam shows advantages of faster heating, shorter fixation time and less colour spread; this is the case if the print has not been dried and also in the pad–steam situation, where there is usually more than sufficient water in the fabric. The term high-temperature (HT) steaming, however, is normally restricted to the treatment of dry prints in superheated steam at temperatures substantially above 100 °C and at atmospheric pressure.

Lockett, the first to advocate this approach, showed that reactive dyes on cellulosic fibres were efficiently fixed in 1 min in steam at 150 °C, provided that a suitable concentration of urea was included in the print paste [11]. The same dyes might require 5 min in steam at 100 °C or in dry air at 150 °C. Reactive dyes can be of small molecular size and low substantivity, so that diffusion occurs more readily than in other dye–fibre interactions, but a liquid medium is required for transport and for chemical reaction. For fixation in dry air, it was known that urea was required to act as the liquid medium, providing good dye solubility both in the later stages of drying and at temperatures above its melting point (132 °C).

When a printed cotton fabric at 20 °C and 7% regain enters HT steam, the steam will rapidly give up its superheat and then condense on to the fibres. The amount of condensed steam will be similar to that for saturated steam (5.5% o.w.f.), the reduction due to the temperature rise before condensation being outweighed by the strong heat absorption (240 kJ kg⁻¹, equivalent to 58 cal g⁻¹) occurring as the urea goes into solution. If the print has provided 20% o.w.f. urea and 12.5% water is also present, the total liquid phase is substantial. A fraction will be retained by the thickener, but the major part will enter the cotton fibres, which can absorb 30% by mass of water at 20 °C.

The moisture content will then fall, as steam at 150 °C has only 20% RH and the equilibrium moisture content of pure cotton in this atmosphere is only 1%. Lockett pointed out that urea forms a eutectic mixture with water, however, and holds some water very tenaciously. The temperature of the dye–fibre system therefore rises rapidly to 100 °C, stays at that level as long as the loss of heat by evaporation is high, and then rises towards the temperature of the steam (Figure 8.10). Reaction between dye and fibre, therefore, proceeds efficiently because the fibre is swollen and the diffusion of dye to ionised sites in the fibre can occur. Diffusion of the larger reactive dye molecules



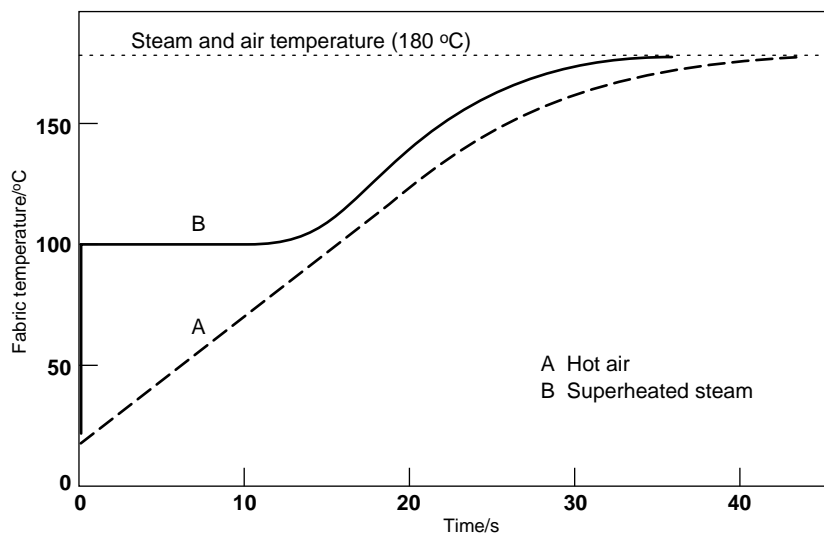

Figure 8.10 Rate of heating of fabric in high-temperature steam and air

into viscose rayon under these conditions is slow, however, and colour yields are often unsatisfactory. As reaction approaches completion the water content has dropped and the amount of dye–fibre bond hydrolysis may therefore be smaller than in saturated steam.

The large amount of urea required adds to the cost of the process and some decomposition occurs, with the production of ammonia and biuret-type products. Some reactive dyes give low colour yields under these conditions, perhaps as a result of reaction with ammonia and of loss of alkali. There is also a need to reduce the nitrogen level in effluents, and alternatives to urea have been sought [12]. The controlled application of water, as a foam, before steaming may provide the ideal alternative [13].

The use of HT steaming for prints on polyester and polyester blend fabrics has become extremely important because the only satisfactory alternative is the batchwise pressure-steaming method. Although continuous pressure steamers have been used (for continuous bleaching, for example), the difficulty of avoiding mark-off at the entry seal is so great that they have never successfully been employed for prints. Steaming at atmospheric pressure and 100 °C is possible if carriers are incorporated in the print paste, but colour yields are limited and only a few disperse dyes are suitable (section 5.4.3).

At a temperature of 180 °C it is possible to achieve satisfactory fixation of many disperse dyes in 1 min, as compared with 30 min pressure steaming at 120 °C or 1 min in dry air at 200 °C. With the increased availability of festoon steamers, longer times



(5–20 min) at temperatures in the range 160–180 °C have been preferred. The presence of urea improves colour yields, but also increases the fixation of thickener and causes undesirable build-up of deposits in the steaming equipment. Urea can be substantially replaced by liquid ‘fixation accelerators’, typically nonionic surface-active agents of high boiling point and low water solubility, in which disperse dyes are soluble at high temperatures.

To understand the mechanism of fixation, it is important to recognise that, for polyester/cellulosic blends, there are three steps:

- diffusion of dye through thickener film
- diffusion across a vapour gap
- diffusion into polyester fibre.

Comparison with the transfer print mechanism is clearly valid. The presence of steam probably has little effect on the passage across the gaps between fibres. It is in the diffusion through thickener films that the combined effect of condensed steam and liquid urea or other fixation accelerator will be important, both from within the thickener film to a surface where sublimation can occur and through the films surrounding polyester fibres. At a high temperature, such as 180 °C, this would be the slow step because the moisture content and thickener swelling would both be low. Lower temperatures and longer times allow the retention of more moisture and a better balance of diffusion rates in the three steps. Diffusion into the polyester fibre is faster in high-temperature steam than in dry air because of the increased molecular mobility [14].

8.4 MISCELLANEOUS TECHNIQUES

In some circumstances, no input of thermal energy is necessary for print fixation. A well-known instance is the printing of diazo salts on naphtholated cotton, where the chemical reaction occurs rapidly at room temperature. Reactive prints on wool and on cotton can also be fixed at room temperature, using a pad–batch process and an interlayer winding of polyethylene film to avoid colour marking-off [15]. Cold fixation is possible only where the dye molecule is small and not aggregated and the fibre in a swollen and thus accessible state.

Reactive dyes of high reactivity, especially those of the vinyl sulphone type, can be treated by a rapid fixation process immediately before entry to the washing-off range. Passage of cellulosic fabric, printed with reactive dyes but no alkali, through a bath containing suitable alkali and a high electrolyte concentration at a temperature of 100 °C can bring about fixation in 10–20 s. Bleeding and marking-off are controlled by the gelling of alginate thickener at the high pH and by the electrolyte. The chemical



costs are high and colour yields lower than in other methods, but this approach is attractive when the capital and labour costs of using a steamer are eliminated. The application of minimum quantities of alkali solution can give savings [2].

Fixation during the drying step is used with selected reactive dyes in the pad-dry process. Such an approach has rarely been attempted for printed dyes because the speed of printing is a variable determined by pattern fitting and similar considerations, which complicate the control of drying conditions. The use of microwave drying would have advantages of high wet-fibre temperature with no overheating of unprinted areas, especially if a low-solids synthetic thickener were used and the amount of dye held outside the fibre therefore minimal.

8.5 WASHING-OFF PROCESSES

Pigment-printing systems have been widely adopted because textile printers have been seeking simple, standard and trouble-free methods requiring minimum capital investment. For many end-uses and for discerning customers, however, the use of dyes will be essential, in which case a washing-off process (and consequently an extra drying operation) is usually required.

If the printed colours are all pale, it is possible that the dye fixation will approach the 100% level. Most print designs include at least one medium or heavy colour, however, and dye fixation levels are always lower at the higher concentrations. Even when little unfixed dye is present the removal of thickener and auxiliary chemicals is usually desirable, and sometimes essential: subsequent finishing processes, the crosslinking of cellulosic fibres or the introduction of water-repellency properties, for example, will give unsatisfactory results on printed fabrics that have not been washed.

It is useful to identify the location and the nature of the substances to be removed:

- in or on the fibre (unfixed dye and some auxiliaries)
- in the thickener phase (dye, auxiliaries, thickening agent and decomposition products).

Substances in the second category can often be swollen and removed quite quickly by vigorous washing at low temperature, but diffusion of dye from within the fibre will be much slower unless high temperatures are used.

Staining of unprinted areas by adsorption of dyes from the wash liquor is a major hazard where the concentration of unfixed dye is allowed to build up in the washing-off process. By careful selection of dyes, thickening agents and conditions of fixation, the amount of loose dye to be removed can be minimised. Regular consideration of possible improvements in dye fixation, and hence cost savings and lower effluent discharge, is recommended.



The optimum conditions for washing-off must be selected for each dye–fibre combination. For rapid removal of unfixed dye from the fibre it will be necessary to use high-temperature wash liquors; however, any dye adsorbed on to white areas will then diffuse into the fibres more rapidly than at lower temperatures. The use in the wash liquor of additives that shift the equilibrium away from adsorption may therefore be justified. Four specific situations are considered in detail below.

8.5.1 Disperse dyes on polyester fabrics

Disperse dyes have a high affinity for polyester, and therefore there is little risk of removing dye that has entered the fibres. Because of the affinity, however, any dye in the wash liquor will stain unprinted areas when the temperature approaches the glass transition value. As much unfixed dye as possible is therefore removed at low wash-liquor temperatures, with correspondingly low dye solubility. The dye is removed in the dispersed, undissolved form, which does not have significant affinity for the fibre.

It is also usual practice to apply a chemical clearing process after the low-temperature wash. A reduction clear, with sodium hydroxide, sodium dithionite and nonionic or cationic surface-active agent, at 60–65 °C will solubilise or destroy loose dye. Dye inside the fibre is not affected, because the reagents do not penetrate the fibre. Clean whites and much improved rubbing fastness of printed areas are therefore obtained, without loss of colour value. Extraction with propanone (acetone) has been used as a test of efficiency of the washing process.

8.5.2 Acid dyes on nylon fabrics

Nylon fibres, especially nylon 6, have very low glass transition temperatures in the wet state, and staining occurs at even moderate temperatures if the conditions are not correctly controlled. Dyes of high affinity are preferred, because high fixation levels can be achieved. Levelling acid dyes are not recommended for medium to strong hues. Complete fixation cannot be attained, however, and unfixed dye should be prevented from staining back during washing-off by:

- using slightly alkaline conditions, so that no protonation of the amino end-groups in the fibre occurs and dye affinity is reduced (Figure 8.11)
- adding a cationic agent, such as Dispersol CWLA (Zeneca), which forms a complex with the dye anion and, because of a solubilising ethylene oxide chain, also reduces the dye affinity (Figure 8.11)
- avoiding the build-up of dye in the wash liquors and restricting their temperature to 60 °C or below.



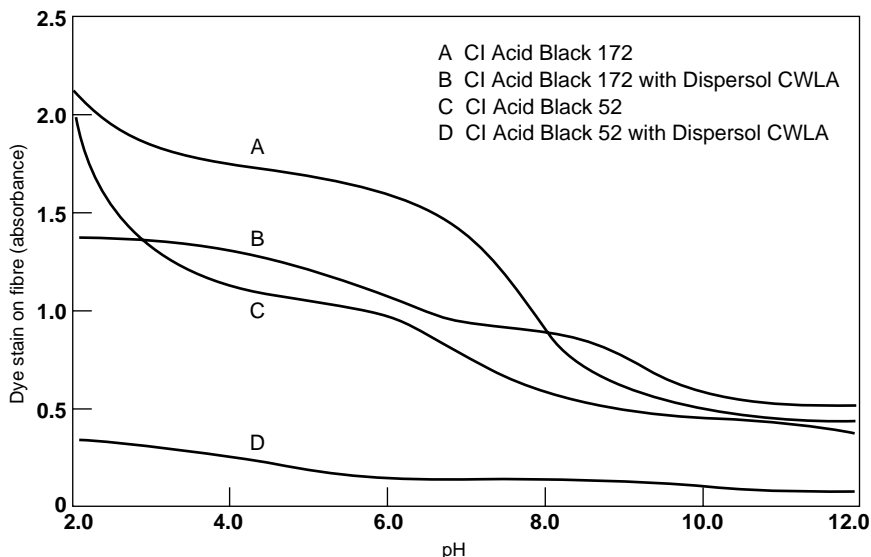

Figure 8.11 Staining of bulked nylon after washing 1000 m at 60 °C

A typical washing sequence, on a winch, for a print on bulked nylon fabric would be:

1. Rinse in cold 1 g l⁻¹ sodium carbonate solution for 10 min
2. Treat in 1 g l⁻¹ sodium carbonate, 1.5 g l⁻¹ Dispersol CWLA, for 10 min at 35 °C
3. Treat in a fresh bath, identical to that for stage 2, but for 10 min at 60 °C
4. Rinse in cold water, until neutral.

8.5.3 Reactive dyes on cellulosic fabric

If suitable fixation conditions are used for reactive dye prints, all the originally reactive colorant will be either covalently bonded to the fibre or hydrolysed. Therefore there should be no danger of loose dye reacting with the fibres in the unprinted areas. If the dye has been selected for printing, it will be of low affinity and, given enough time and water, all the hydrolysed dye can be removed to leave clean white grounds. The amount of hydrolysed dye may be substantial, however, and the rate of removal depends on the diffusion rate from the fibre (as all cellulosic fibres absorb significant amounts of solution and of dye).

Within the ranges of reactive dyes recommended for printing there are dyes giving high fixation (90%), moderate fixation (75%) and low fixation (60%). The range of affinity also stretches from very low to only reasonably low. The amount of hydrolysed dye to be removed may therefore vary by a factor of 4, and the ease of removal can also



vary widely. The danger is that hydrolysed dye will be left in the fabric and cause marking-off complaints at the first domestic wash.

When the wash-off behaviour is studied, it is found that the factor of principal importance is the temperature of the wash liquor. At 60 °C, even the best dyes require washing for more than 4 min, but at 90 °C the same dyes can be completely cleared in 90 s and the difference due to variations in affinity is very much reduced (Figure 8.12).

As open-width washing machines are unlikely to provide 90 s hot washing (Table 8.2 [16]), when such machines are used it is necessary to maintain a close control of all operating conditions and of the results.

The use of dye concentrations above the maximum recommended level in the print paste will overload the wash liquors.

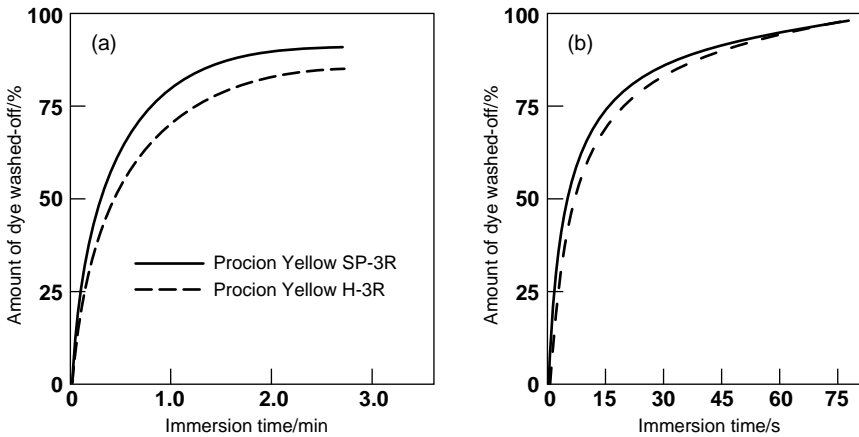

Figure 8.12 Removal of reactive dyes (CI Reactive Orange 66 and 12) at different temperatures, (a) at 60 °C, (b) at 90 °C

Table 8.2 Washing times in an eight-box range (10 m fabric per box)

Speed /m min ⁻¹	Time/s		
	Boxes 1 and 8	Boxes 2–7 (hot)	Total
30	40	120	160
60	20	60	80
100	12	36	48

General recommendations for washing-off are:

1. Start with a cold-water rinse that swells and removes thickener and dye in the thickener film; a high flow rate, with overflow, is advantageous
2. Maintain the wash liquor temperature at as high a level as possible
3. Use as long an immersion time as is practicable
4. Avoid the build-up of hydrolysed dye in the later units, preferably by using the counterflow principle
5. Avoid the use of water with significant hardness or electrolyte content.

The presence of residual hydrolysed dye after the washing process is readily detected by sandwiching a sample of the print between wet and dry white cotton fabric and drying with a hot iron applied to the dry side. The wicking of water through the print brings all the loose dye to the heated surface.

8.5.4 Mixtures of disperse and reactive dyes on polyester/cellulose blends

The washing-off of disperse and reactive dye mixtures printed on these blend fabrics presents the printer with a two-fold problem. In the first place, the efficiency of fixation is inevitably lower than when single-fibre fabrics are printed and therefore the amount of unfixed dye to be removed is larger. Secondly, the ideal conditions for the reactive dye–cellulose system (high washing temperature) are the worst possible for the disperse dye–polyester system. Further, reduction clearing cannot be used to remove unfixed disperse dye because the reactive dyes within the cellulosic fibres would be attacked.

A lengthy procedure must be adopted, with the use of selected surfactant mixtures. After thorough cold rinsing, at least one wash in 5 g l⁻¹ Synperonic BD (or similar nonionic–anionic mixture) at 50–60 °C is followed by use of the same agent at a higher temperature, until no further dye is removed. Because the use of conventional disperse and reactive dyes is so difficult, the advantages of using those disperse dyes that can be cleared by treatment in hot alkaline conditions are very obvious (section 5.9.2).

8.6 WASHING-OFF EQUIPMENT

The objectives at this stage of print production are:

- wetting and swelling the thickener film
- removing thickening agent, unfixed dye and auxiliary chemicals
- provision of time at a suitable temperature for the conversion of some insoluble colorants (vat, azoic) to their true colour and fastness.



Most machinery designed for these purposes is continuous in operation, because of the economy in water, energy and labour costs, compared with batchwise operation [17]. When small fabric quantities or fabric-handling problems make continuous treatment impracticable, however, the use of a winch beck is common. The maximum use is made of the counterflow principle of wash-liquor movement, in order to keep the water consumption as low as possible.

Treatment of the fabric in the open-width form has many advantages and the traditional washing range (Figure 8.13), with 8–10 boxes, is compact and productive. The fabric is pulled through each unit (box) by its driven-roller mangle, which squeezes out contaminated liquor held in the fabric interstices. Fresh wash liquor is then picked up in the following unit, and dilutes the contaminants still in the fabric.

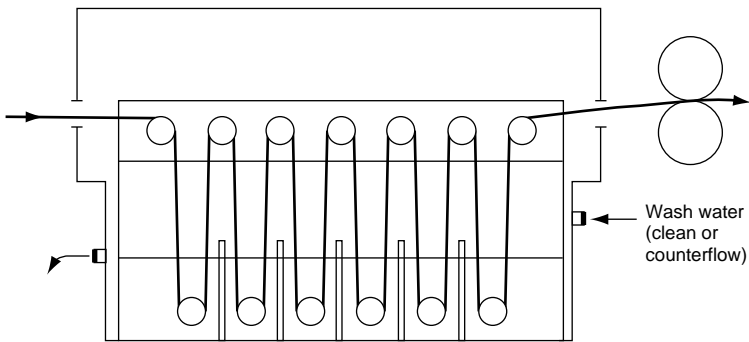

Figure 8.13 Single unit of an open-width washing range

The removal of soluble materials from the fabric is accomplished by two mechanisms, diffusion and liquid interchange. Diffusion is slow, even when there is little or nothing to be removed from within the fibre, because there will always be water held between the fibres and a stationary boundary layer of water on the fabric surfaces, through which diffusion must occur. The thickness of the boundary layer depends on the velocity at which the wash liquor is moving, relative to the fibres. When the liquor is moved at high velocity through the fabric the boundary layer will be reduced to a minimum mean thickness, but there will still be spaces between fibres where little movement occurs. Raising the temperature accelerates removal by diffusion because the diffusion coefficient is increased and the viscosity of water is reduced, which leads to a thinner boundary layer.

Liquid interchange (the replacement of liquid held inside the fabric structure by washing liquor) can give faster removal of contaminants that have already diffused into the liquor. This happens whenever there is a pressure difference within the washing

liquor causing bulk movement of liquid. For example, when fabric passes around a bottom roller in a washing unit, a small hydraulic pressure builds up between the fabric and the roller surface, and tends to force liquid through the fabric. The larger the roller diameter and the higher its speed, the greater is the pressure (which is exactly comparable to that under a rod squeegee in rotary-screen printing). Some washing machines have been fitted with fluted rollers that produce alternating positive and negative pressures and, therefore, pulsing of water through the fabric as it passes around each roller.

The use of mangles, which reduce the volume of liquor held within the fabric by at least 50%, provides perhaps the most effective means of bringing about liquid interchange. Small pressure rollers acting on the upper carrying rollers of open-width washing units (Figure 8.13) are also used for this purpose. A different approach, used especially for knitted fabrics, draws wash liquor through the fabric as it passes around a perforated cylinder (Figure 8.14). Because the fabric is held in contact with the driven cylinder it is not extended in its passage, and can even be overfed on to the cylinder in order to allow some shrinkage to occur.

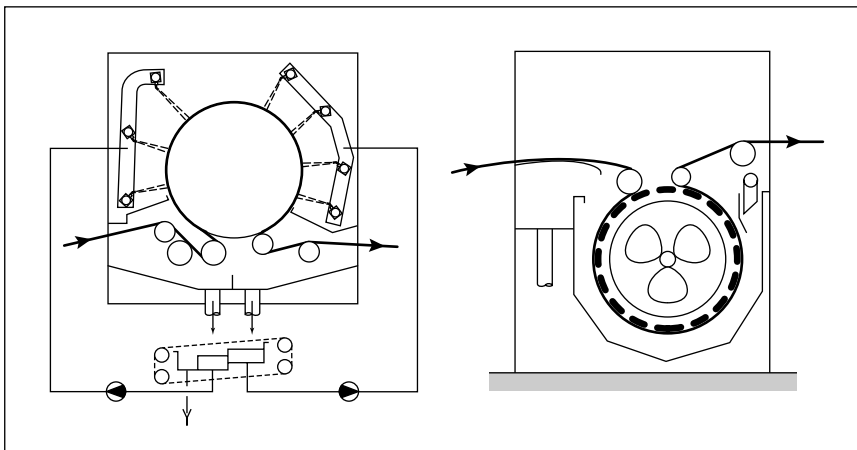

Figure 8.14 Single spray (left) and suction drum (right) washing units for knitted fabrics (Babcock)

Parish has shown that the performance of any washing machine depends on the amount of water used and on the efficiency with which the water is used [18]. For any given set of conditions an efficiency parameter, which is characteristic of the machine and independent of the flow of water, can be determined. The performance of a single

unit C_1/C_0 , i.e. the ratio of impurity concentrations in the fabric after and before the wash, is given by Eqn 8.2:

$$\frac{C_1}{C_0} = \frac{1 - K + KF}{1 - K + F} \tag{8.2}$$

where K is the efficiency parameter (equal to C_1/C_0 for a wash in clean water) and F is the flow of wash water per unit mass of solution in the fabric that enters in unit time.

The use of this relationship allows the calculation of water flow required for a machine of known K value, or of the K value required when the water available is limited. The value of K can be varied by changing the temperature of the wash liquor, so that energy may be saved by using a temperature no higher than necessary.

The washing performance of a series of units is given by multiplying together the values of each separate unit. If, for example, C_1/C_0 were 0.3 for each of four units, then the overall performance would be $0.3^4 = 0.0081$, i.e. a 99.2% removal of impurity.

The value of K is determined by time of contact, temperature, amount of interchange and properties of the impurity. The use of counterflow would be obtained, in theory, by applying water at the top of a tower with fabric running upwards from the bottom. Ideal conditions are approached in well-designed horizontal-path washers

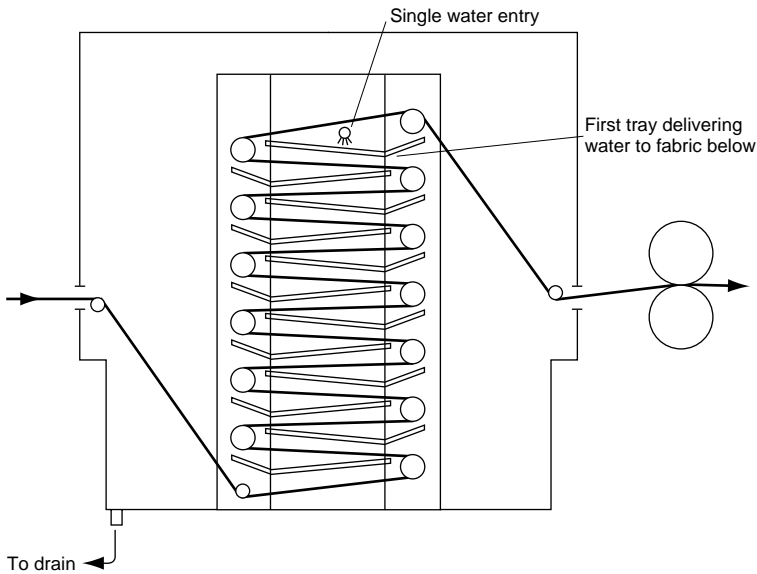

Figure 8.15 Arrangement for a horizontal-path washer

(Figure 8.15), but on wide fabric it is likely to be difficult to maintain uniform treatment across the width. Good counterflow is obtained using the traditional vertical arrangement of units by inserting partitions between bottom rollers and arranging for gravity overflow. Some modification of the open-width washer is required to allow time delays for thickener film swelling and for vat dye soaping. Simple delay scrays, brattice conveyors on to which fabric is rippled and sprayed, J-type units and rotating wash wheel units have all been used. Many printers have continued to use traditional rope-form washers, which provide low tension, mechanical action and extended times. Their efficiency can therefore be excellent, but more space is occupied and scutching is necessary to convert back to open width. Most rope washers consist of a series of units, like winch dyeing machines, with fabric taking a spiral path from entry side to exit side of each unit. An alternative arrangement, introduced by Cilander, uses an efficient counterflow system. The washer is essentially a continuous serpentine tube with water entering only at the fabric exit; it uses water more efficiently than does the conventional rope washer.

REFERENCES

1. Dyer, **161** (1979) 13.
2. C K Dave and L W C Miles, *J.S.D.C.*, **98** (1982) 340.
3. M Fox, *Rev. Prog. Coloration*, **4** (1973) 18.
4. W J Marshall and R H Peters, *J.S.D.C.*, **69** (1953), 583.
5. R Fahnoe, *Amer. Dyestuff Rep.*, **38** (1949) 663.
6. R Thornton and W F Liquorice, *J.S.D.C.*, **72** (1956) 472.
7. K T Fell and R Postle, *Text. Res. J.*, **40** (1970) 683.
8. J C Isarin and R B M Holweg, *J.S.D.C.*, **109** (1993) 28.
9. A B Meggy, *J.S.D.C.*, **59** (1943) 192.
10. A R Urquhart, *J. Text. Inst.*, **34** (1943) T103.
11. A P Lockett, *J.S.D.C.*, **83** (1967) 213.
12. J R Provost, *J.S.D.C.*, **108** (1992) 260.
13. H Van Ettekoven, *Amer. Dyestuff Rep.*, **82** (2) (1993)
14. J O Warwicker, *J.S.D.C.*, **88** (1972) 142.
15. R S Asquith, *J.S.D.C.*, **86** (1970) 393.
16. W J Marshall, *J.S.D.C.*, **82** (1966) 169.
17. M E Atkinson, *Text. Chem. Colorist*, **24** (3) (1992) 25.
18. G J Parish, *J.S.D.C.*, **78** (1962) 109.

