

***ARMY TM 9-1005-319-10
AIR FORCE TO.11W3-5-5-41
NAVY SW 370-BU-OPI-010 Rev 1**

**OPERATOR'S MANUAL
FOR**

**RIFLE, 5.56 MM, M16A2 W/E
(1005-01-128-9936)(EIC:4GM)**

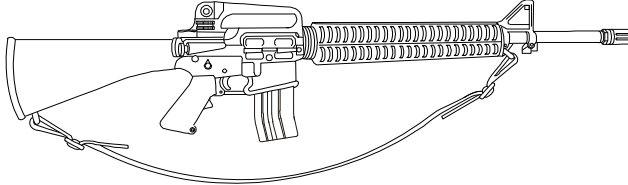

**RIFLE, 5.56 MM, M16A3
(1005-01-357-5112)**

**RIFLE, 5.56 MM, M16A4
(1005-01-383-2872)(EIC:4F9)**

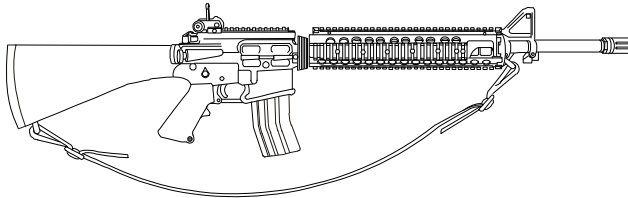

**CARBINE, 5.56 MM, M4 W/E
(1005-01-231-0973)(EIC:4FJ)**

**CARBINE, 5.56 MM, M4A1
(1005-01-382-0953)(EIC:4GC)**

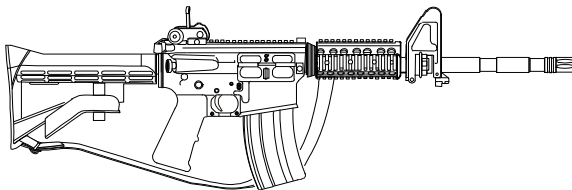

*Supersedes TM 9-1005-319-10, Air Force TO.11W3-55-41, Navy SW 370-BUJ-OPI-010,
01 October 1998.

**HEADQUARTERS, DEPARTMENTS OF THE ARMY,
AIR FORCE, AND NAVY**

JUNE 2010

DISCLOSURE NOTICE - This information is furnished upon the condition that it will not be released to another nation without the specific authority of the Department of the Army of the United States; that it will be used for military purposes only; that individual or corporate rights originating in the information, whether patented or not, will be respected; that the recipient will report promptly to the United States any known or suspected compromise; and that the information will be provided substantially the same degree of security afforded it by the Department of Defense of the United States. Also, regardless of any other markings on the document, it will not be downgraded or declassified without written approval of the originating United States agency.

DISTRIBUTION STATEMENT C - Distribution authorized to U.S. Government agencies and their contractors. This publication is required for administration and operational purposes, as determined 26 October 2005. **ARMY ONLY:** Other requests for this document shall be referred to U. S. Army TACOM Life Cycle Management Command, ATTN: AMSTA-LCL-MPP/TECH PUBS, 1 Rock Island Arsenal, Rock Island, IL 61299-7630. **AIR FORCE ONLY:** Other requests for this document must be referred to 406 SCMS/GUHA, Robins AFB, GA 31098-1813. **NAVY ONLY:** Send letter directly to Commander, Code JXRS, Bldg. 2521E, NAVSURF WARCENDIV, 300 Hwy 361, Crane, IN 47522-5001.

DESTRUCTION NOTICE - Destroy by any method that will prevent disclosure of contents or reconstruction of the document.

WARNING SUMMARY

This warning summary contains general safety warning and hazardous materials warnings that must be understood and applied during operation and maintenance of this equipment. Failure to observe these precautions could result in serious injury or death to personnel. Also included are explanations of safety and hazardous materials icons used within the Technical Manual.

FIRST AID

For first aid information, refer to FM 4-25.11, First Aid
Air Force Personnel, refer to AFMAN 44-163 (I) First Aid

EXPLANATION OF SAFETY WARNING ICONS



WEAPON FIRE - accidental discharge of a weapon could penetrate the body causing serious injury or death.



EXPLOSION - rapidly expanding symbol shows that the material may explode if subjected to high temperatures, sources of ignition or high pressure.

GENERAL SAFETY WARNING DESCRIPTIONS

WARNING

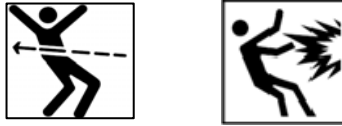

ACCIDENTAL DISCHARGE

The weapon **MUST** be cleared before inspecting, cleaning, disassembly, transporting, or storing to be considered **SAFE**.

DO NOT squeeze the trigger until weapon is cleared.

ALWAYS clear weapon before installation of blank firing attachment.

DO NOT fire directly at anyone less than 20 feet away when using the blank firing attachment.

Blank firing attachment is used only with M200 blank 5.56mm round.

Weapon can chamber a round when dropped or jarred if loaded magazine is in place regardless of whether the bolt carrier assembly is in forward position or locked to the rear.

Ensure weapon is pointed in safe direction when loaded.

ALWAYS clear weapon before starting a functional check.

DO NOT squeeze the trigger until weapon is cleared. Ensure chamber is empty and no ammunition is chambered.

Keep clear of muzzle when inspecting malfunctions.

ALWAYS clear weapon before installing top sling adapter.

Your weapon is now loaded. Ensure it is pointed in a **SAFE** direction.

ALWAYS clear the weapon before cleaning.

WARNING SUMMARY - Continued

WARNING

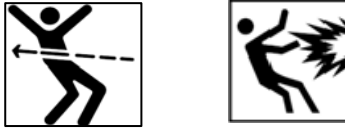

MISFIRE

If weapon stops firing with a live round in the chamber of a hot barrel, remove the round within 10 seconds. If the round is not removed within 10 seconds, remove magazine and wait 15 minutes with the weapon pointed in a safe direction to avoid injury during possible cookoff. **ALWAYS** keep face away from the ejection port when clearing a hot chamber.

STOP firing immediately if an audible “**POP**” is heard or reduced **RECOIL** is experienced while firing weapon. These could indicate an incomplete powder burn and/or a bullet stuck in the bore. Retract bolt slowly, clear weapon, and check for unburned powder grains in the receiver or bore and/or bullet stuck in bore. Remove unburned powder or bullet from bore before resuming firing. Return weapon to the field maintenance if the bullet is stuck in the bore.

DO NOT fire if water is present in barrel.

DO NOT interchange bolts between weapons.

Ensure cam pin is installed in the bolt carrier assembly. The weapon will explode when fired if cam pin is not installed.

WARNING



AMMUNITION

DO NOT keep live ammunition in work area.

DO NOT use a live round to perform this process.

DO NOT FIRE:

Corroded ammunition.

Dented cartridges.

Cartridges with loose bullets.

Cartridges exposed to extreme heat (135° Fahrenheit / 57° Celsius) until cartridges have cooled.

Cartridges with the bullet pushed in (short rounds).

ALWAYS turn in bad rounds to range Non-Commissioned Officer (NCO).

DEFINITION OF ALERTS THROUGHOUT THIS MANUAL:

WARNING: Identifies a danger to the operator or others near the operator.

CAUTION: Identifies risk of damage to the equipment.

NOTE: Used to highlight essential procedures, conditions, statements or important instructional data.

LIST OF EFFECTIVE PAGES/WORK PACKAGES

NOTE: Zero in the “Change No.” column indicates an original page or work package.

Dates of issue for original manual is:

Original..... 30 June 2010

TOTAL NUMBER OF PAGES FOR FRONT AND REAR MATTER IS 20 AND TOTAL NUMBER OF WORK PACKAGES IS 22 CONSISTING OF THE FOLLOWING:

Page/WP No.	*Change No.
Front Cover.....	0
Warning Summary.....	0
LOEP	0
Title.....	0
Chapter 1.....	0
WP 0001 00.....	0
WP 0002 00.....	0
WP 0003 00.....	0
WP 0004 00.....	0
Chapter 2.....	0
WP 0005 00.....	0
WP 0006 00.....	0
WP 0007 00.....	0
WP 0008 00.....	0
WP 0009 00.....	0
WP 0010 00.....	0
Chapter 3.....	0
WP 0011 00.....	0
Chapter 4.....	0
WP 0012 00.....	0
WP 0013 00.....	0
WP 0014 00.....	0
WP 0015 00.....	0
WP 0016 00.....	0
WP 0017 00.....	0
Chapter 5.....	0
WP 0018 00.....	0
Chapter 6.....	0
WP 0019 00.....	0
WP 0020 00.....	0
WP 0021 00.....	0
WP 0022 00.....	0
Index 1 - Index 3.....	0

ARMY TM 9-1005-319-10
AIR FORCE TO 11W3-5-5-41
NAVY SW 370-BU-OPI-010 Rev1

HEADQUARTERS
DEPARTMENTS OF THE
ARMY, AIR FORCE
AND NAVY
' \$>I B9'&\$%\$

**OPERATOR'S MANUAL
FOR
RIFLE, 5.56 MM, M16A2 W/E
(1005-01-128-9936)(EIC:4GM)
RIFLE, 5.56 MM, M16A3
(1005-01-357-5112)
RIFLE, 5.56 MM, M16A4
(1005-01-383-2872)(EIC:4F9)
CARBINE, 5.56 MM, M4 W/E
(1005-01-231-0973)(EIC:4FJ)
CARBINE, 5.56 MM, M4A1
(1005-01-382-0953)(EIC:4GC)**

REPORTING ERRORS AND RECOMMENDING IMPROVEMENTS

(A) You can help improve this publication. If you find any errors, or if you would like to recommend any improvements to the procedures in this publication, please let us know. The preferred method is to submit your DA Form 2028 (Recommended Changes to Publications and Blank Forms) through the Internet, on the Army Electronic Product Support (AEPS) website. The Internet address is <https://aeps.ria.army.mil>. The DA Form 2028 is located under the Public Applications section in the AEPS Public Home Page. Fill out the form and click on SUBMIT. Using this form on the AEPS will enable us to respond quicker to your comments and better manage the DA Form 2028 program. You may also mail, email, or fax your comments or DA Form 2028 directly to the U.S. Army TACOM Life Cycle Management Command. The postal mail address is U.S. Army TACOM Life Cycle Management Command, ATTN: AMSTA-LCL-MPP / TECH PUBS, 1 Rock Island Arsenal, Rock Island, IL 61299-7630. The email address tacomlcmc.daform2028@us.army.mil. The fax number is DSN 793-0726 or Commercial (309) 782-0726.

(F) Air Force-Send Air Force AFTO form 22 through unit's respective MAJCOM in the Joint Computer-aided Acquisition and Logistics Support (JCALS) system. Refer to Section 5 of Air Force Technical Order 00-5-1 for guidance.

(N) Navy-Send letter directly to: Commander, Code JXN, Bldg. 3422, NAVSURF WARCENDIV, 300 Hwy 361, Crane, IN 47522-5001.

All issues will be answered and returned to suggester.

*Supersedes TM 9-1005-319-10, Air Force TO.11W3-5-5-41, Navy SW 370-BUJ-OPI-010, 01 October 1998.

DISTRIBUTION STATEMENT C - Distribution authorized to U.S. Government agencies and their contractors. This publication is required for administration and operational purposes, as determined 26 October 2005. **ARMY ONLY:** Other requests for this document shall be referred to U.S. Army TACOM Life Cycle Management Command, ATTN: AMSTA-LCL-MPP/TECH PUBS, 1 Rock Island Arsenal, Rock Island, IL 61299-7630. **AIR FORCE ONLY:** Other requests for this document must be referred to 406 SCMS/GUHA, Robins AFB, GA 31098-1813. **NAVY ONLY:** Send letter directly to: Commander, Code JXRS, Bldg. 2521E, NAVSURF WARCENDIV, 300 Hwy 361, Crane, IN 47522-5001.

WARNING - This document contains technical data whose export is restricted by the Arms Export Control Act (Title 22, U.S.C., Sec 2751 et seq) or the Export Administration Act of 1979, as amended, Title 50A, U.S.C., App. Violations of these export laws are subject to severe criminal penalties. Disseminate in accordance with provisions of DOD Directive 5230.25.

DESTRUCTION NOTICE - Destroy by any method that will prevent disclosure of contents or reconstruction of the document.

TABLE OF CONTENTS

WP Sequence No.

CHAPTER 1 GENERAL INFORMATION	
General Information	0001 00
Equipment Description and Data	0002 00
Location And Description of Major Components	0003 00
Theory of Operation	0004 00
CHAPTER 2 OPERATOR INSTRUCTIONS	
Description and Use of Operator's Controls and Indicators	0005 00
Operations Under Usual Conditions	0006 00
Operations Under Unusual Conditions	0007 00
Function Check	0008 00
25 Meter Zeroing Procedures	0009 00
Installation of Equipment	0010 00
CHAPTER 3 OPERATOR TROUBLESHOOTING PROCEDURES	
Troubleshooting	0011 00
CHAPTER 4 OPERATOR MAINTENANCE INSTRUCTIONS	
Preventive Maintenance Checks and Services (PMCS)	0012 00
Disassembly Instructions	0013 00
Cleaning Instructions	0014 00
Inspection Instructions	0015 00
Lubrication Instructions	0016 00
Reassembly Instructions	0017 00
CHAPTER 5 AMMUNITION	
Ammunition	0018 00
CHAPTER 6 SUPPORTING INFORMATION	
References	0019 00
Components of End Item/ Basic Issue Items	0020 00
Additional Authorization Items	0021 00
Expendable/Durable Supplies and Materials	0022 00
Alphabetical Index	Index-1

HOW TO USE THIS MANUAL

References

a. References are to pages in this manual.

b. Text may refer to illustrations by numbered callouts. A number in parentheses in the text corresponds with a number on the illustration when an item is called out in a procedure.

Indexes

a. Table of Contents. The Table of Contents lists all chapters and work packages as they appear in the manual.

b. Alphabetical Index. This index is an extensive subject index for the entire manual. Page numbers list where in the manual to find each subject listed in the index.

Organization

This manual covers the operation of the M16A2, M16A3, M16A4 Rifles and the M4 and M4A1 Carbines. The manual is divided into six chapters. Chapters are divided into Work Packages. The six chapters are listed in the Table of Contents

CHAPTER 1
GENERAL INFORMATION

OPERATOR**GENERAL INFORMATION**

SCOPE

TYPE OF MANUAL: Operator's Manual

This manual provides operation and service instructions for the M16A2, M16A3, M16A4 Rifles and the M4 and M4A1 Carbines.

PURPOSE OF EQUIPMENT. The purpose of the weapons is to provide personnel offensive/defensive capabilities for engagement of targets in the field.

ONLY the M16A2 configuration is depicted when a procedure is common to both the M16 Rifle and M4 Carbine. Procedures unique to a weapon are identified with the correct weapon. Refer to appropriate Appendices in this manual for the operation and service of adapter rails.

MAINTENANCE FORMS, RECORDS, AND REPORTS

Department of the Army forms and procedures used for equipment maintenance will be those prescribed by DA PAM 750-8, The Army Maintenance Management System (TAMMS) Users Manual. Maintenance Forms and records used by Air Force Personnel are prescribed in AFI 21-101, the applicable TO-00-20 Series, AFI 36-2226 and TO 11W-1-10.

Accidents involving injury to personnel or damage to materiel will be reported on DA Form 285 (Accident Report) in accordance with AR 385-40. Explosives and ammunition malfunctions will be reported on DA Form 4379 in accordance with AR 75-1. Electronic copies of the DA Forms and Army Regulations can be accessed at <http://www.apd.army.mil>. Air Force will follow the procedures outlined in AFI 36-226, Combat Arms Program.

CORROSION PREVENTION AND CONTROL (CPC)

Corrosion problems with equipment must be reported in order to correct problems and make improvements to prevent problems in future equipment.

Equipment corrosion problems include the deterioration, cracking, softening, swelling, and breaking of all materials including metal, plastic, contacts, and foam case inserts.

Corrosion problems should be reported on Standard Form 368, *Product Quality Deficiency Report*. Clearly identify CPC problems with keywords such as "corrosion," "rust," "cracking," or any other words clearly describing the problem. Submit Standard Form 368 to the address listed in DA Pam 750-8.

DESTRUCTION OF MATERIAL TO PREVENT ENEMY USE

Refer to TM 750-244-7 for destruction procedures of this equipment to prevent use of equipment by enemy.

EQUIPMENT IMPROVEMENT RECOMMENDATION (EIR)

(A) Army- If your M16A2, M16A3, M16A4 Rifles and the M4 and M4A1 Carbines needs improvement, let us know. Send us an EIR. You, the user, are the only one who can tell us what you don't like about your equipment. Let us know why you don't like the design or performance. Put it on an SF 368 (Product Quality Deficiency Report). Mail it to us at: Commander, ATTN: AMSRD-AAR-QEP-C, RDECOM, 1 Rock Island Arsenal, Rock Island, IL 61299-7300 (Fax: DSN 793-6653, Commercial (309) 782-6653) (E-mail: ROCK-QDRS@conus.army.mil). We will send you a reply.

(F) Air Force- Send Air Force AFTO form 22 through unit's respective MAJCOM in the Joint Computer-aided Acquisition and Logistics Support (JCALS) system. Refer to Section 5 of Air Force Technical Order 00-5-1 for guidance.

(N) Navy- Send letter directly to: Commander, Code JXN, Bldg. 3422, NAVSURF WARCENDIV, 300 Hwy 361, Crane, IN 47522-5001.

All issues will be answered and returned to the suggester.

END WORK PACKAGE

OPERATOR**LOCATION AND DESCRIPTION OF MAJOR COMPONENTS**

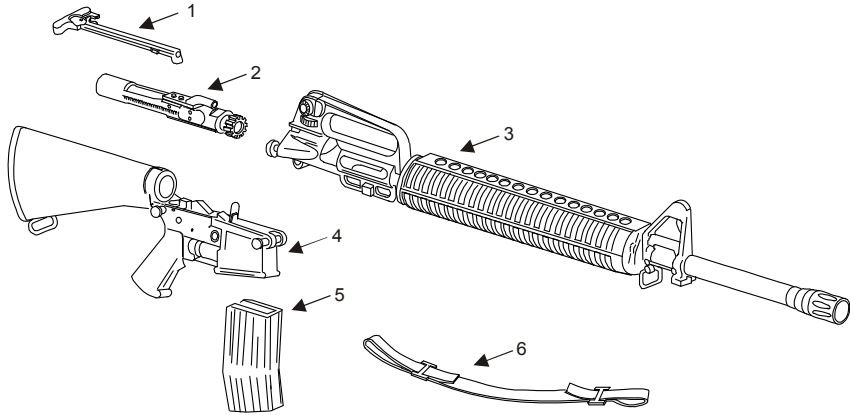
**M16A2**

CHARGING HANDLE ASSEMBLY (1) provides initial charging of weapon. Locks forward during sustained fire.

BOLT AND BOLT CARRIER ASSEMBLY (2) provides stripping, chambering, locking, firing, extraction, and ejection of cartridges using the buffer spring and projectile propelling gases for power.

UPPER RECEIVER AND BARREL ASSEMBLY (3) provides support for bolt carrier assembly. The barrel chambers the cartridge for firing and directs the projectile.

LOWER RECEIVER AND BUTTSTOCK ASSEMBLY (4) assists in basic function of weapon and shoulders the weapon.

CARTRIDGE MAGAZINE (5) holds 30 cartridges and positions the rounds for feeding.

SMALL ARMS SLING (6) is used as a means to carry the weapon.

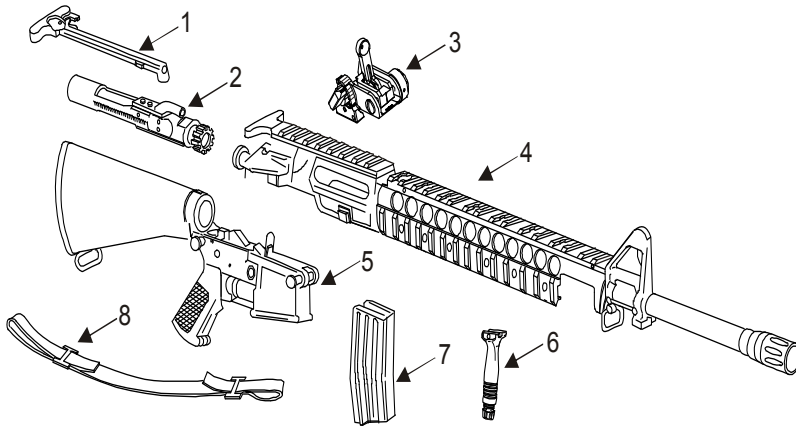
**M16A3/A4**

CHARGING HANDLE ASSEMBLY (1) provides initial charging of weapon. Locks forward during sustained fire.

BOLT AND BOLT CARRIER ASSEMBLY (2) provides stripping, chambering, locking, firing, extraction, and ejection of cartridges using the buffer spring and projectile propelling gases for power.

BACK-UP IRON SIGHT (3) is used to aim weapon if optics are not present or inoperable.

UPPER RECEIVER AND BARREL ASSEMBLY (4) provides support for bolt carrier assembly. The barrel chambers the cartridge for firing and directs the projectile.

LOWER RECEIVER AND BUTTSTOCK ASSEMBLY (5) assists in basic function of the weapon and shoulders the weapon.

PISTOL GRIP (6) is used to increase stability of weapon when firing.

CARTRIDGE MAGAZINE (7) holds 30 cartridges and positions the rounds for feeding.

SMALL ARMS SLING (8) is used as a means to carry the weapon.

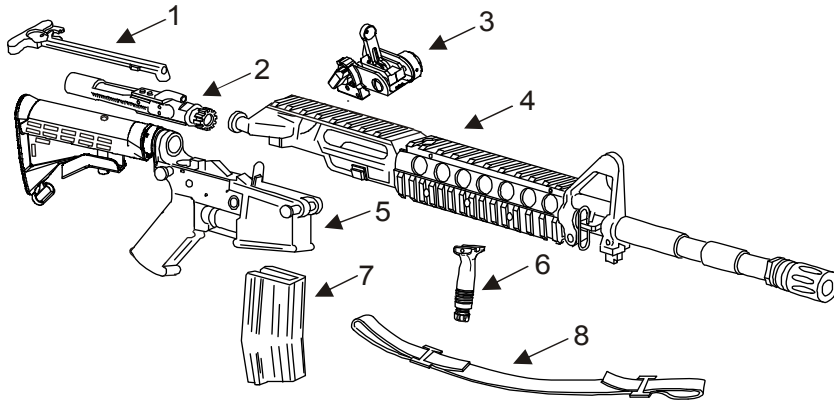

M4/M4A1

CHARGING HANDLE ASSEMBLY (1) provides initial charging of weapon. Locks forward during sustained fire.

BOLT AND BOLT CARRIER ASSEMBLY (2) provides stripping, chambering, locking, firing, extraction, and ejection of cartridges using the buffer spring and projectile propelling gases for power.

BACK-UP IRON SIGHT (3) is used to aim weapon if optics are not present or inoperable.

UPPER RECEIVER AND BARREL ASSEMBLY (4) provides support for bolt carrier assembly. The barrel chambers the cartridge for firing and directs the projectile.

LOWER RECEIVER AND BUTTSTOCK ASSEMBLY (5) assists in basic function of the weapon and shoulders the weapon.

PISTOL GRIP (6) is used to increase stability of weapon when firing.

CARTRIDGE MAGAZINE (7) holds 30 cartridges and positions rounds for feeding.

SMALL ARMS SLING (8) is used as a means to carry the weapon.

END OF WORK PACKAGE

OPERATOR

THEORY OF OPERATION

1. Squeeze the trigger to release the hammer. The hammer strikes the firing pin, which strikes the primer and ignites the propellant.
2. Gases from the burning propellant push the projectile through the barrel of the weapon.
3. Barrel rifling rotates the projectile providing stability during flight.
4. When round reaches approximate end of barrel, expanding gases from the burning propellant pass through gas port, gas tube and into the bolt carrier assembly forcing it to the rear. This causes the bolt to extract and eject the spent cartridge case and chamber a new round.

END OF WORK PACKAGE

CHAPTER 2
OPERATOR INSTRUCTIONS

OPERATOR

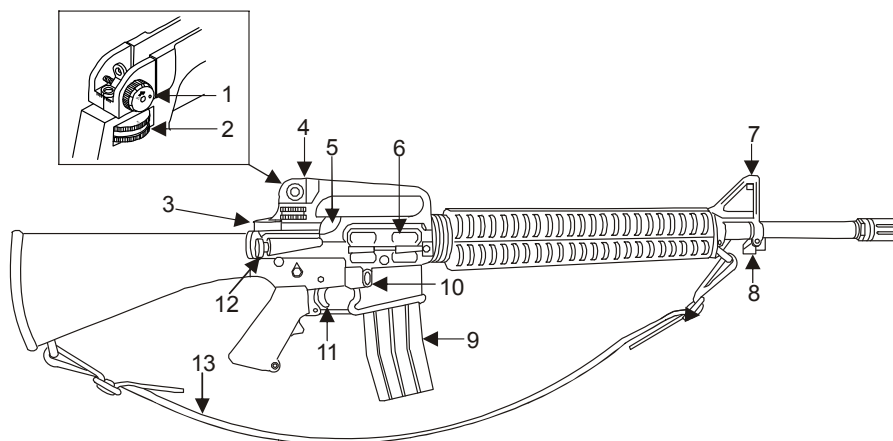
DESCRIPTION AND USE OF OPERATOR CONTROLS
AND INDICATORS

RIGHT VIEW M16A2

WINDAGE KNOB (1) adjusts sight for effect of wind.

ELEVATION KNOB (2) adjusts the rear sight for range changes.

CHARGING HANDLE ASSEMBLY (3) is used for initial charging of weapon and chambering of round.

REAR SIGHT ASSEMBLY (4) contains short range (0-200m) and long range (300m+) apertures and adjustment controls.

BRASS DEFLECTOR (5) deflects empty cartridges.

EJECTION PORT COVER (6) prevents debris from entering chamber when closed. Keep closed when not firing.

FRONT SIGHT ASSEMBLY (7) contains adjustable front sight post.

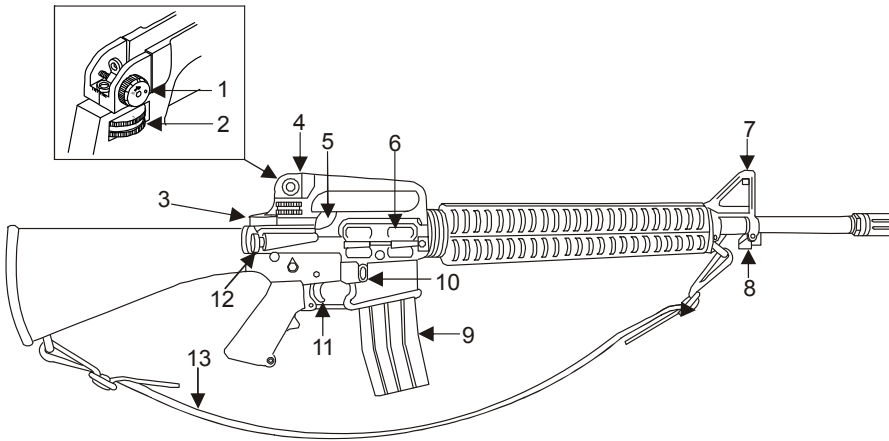
**RIGHT VIEW M16A2**

BAYONET LUG (8) provides bayonet attachment.

CARTRIDGE MAGAZINE (9) holds 5.56mm ammunition.

MAGAZINE CATCH ASSEMBLY (10) locks magazine in place and also releases magazine from magazine well when depressed.

TRIGGER (11) initiates firing sequence when squeezed.

FORWARD ASSIST ASSEMBLY (12) ensures the bolt is fully closed and locked.

SLING (13) is an adjustable means to carry weapon.

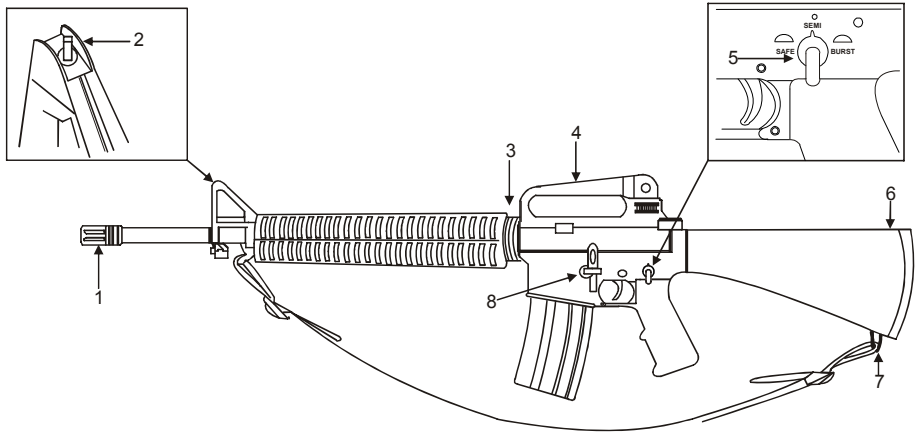

LEFT VIEW M16A2

COMPENSATOR (1) prevents muzzle rising while firing.

FRONT SIGHT POST (2) adjusts strike of bullet up or down.

SLIP RING (3) holds handguards or rail system in place.

CARRYING HANDLE (4) allows carrying of weapon and additional mounting capabilities.

SELECTOR LEVER (5) selects mode of fire and places weapon on safe.

BUTTSTOCK ASSEMBLY (6) houses buffer assembly, spring and lower receiver extension.

SLING SWIVEL (7) allows sling to attach to weapon.

BOLT CATCH (8) holds bolt to rear after firing last round.

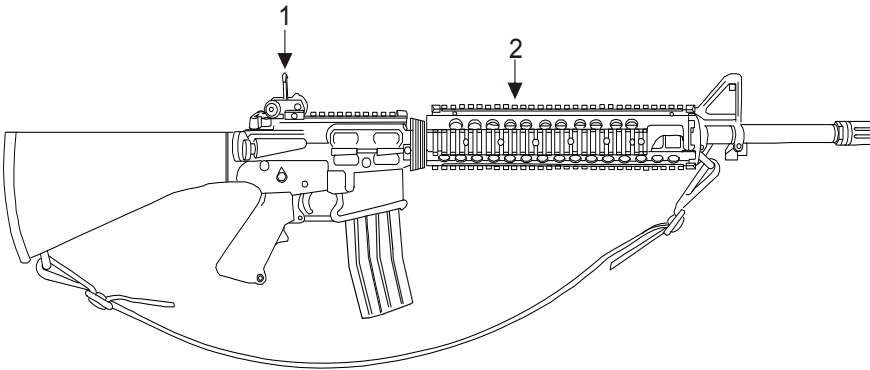

RIGHT VIEW M16A3/A4

NOTE

All controls and descriptions of the M16A2 are applicable to the M16A3 and M16A4 except the carrying handle, rear sight assembly, windage knob, and elevation knob, which have been replaced by the adapter rails and backup iron sight. The selector lever settings are SAFE/SEMI/AUTO for the M16A3.

BACKUP IRON SIGHT (1) is used to aim weapon if optics are not present or inoperable.

M5 ADAPTER RAIL (2) allows attachment of various weapon accessories.

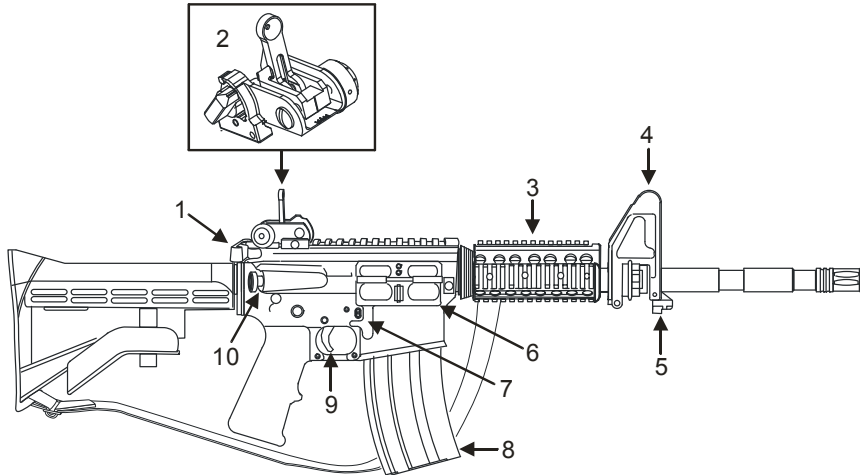

RIGHT VIEW M4/M4A1

CHARGING HANDLE (1) is used for initial charging of weapon and chambering of round.

BACKUP IRON SIGHT (2) is used to aim weapon if optics are not present or inoperable.

M4 ADAPTER RAIL (3) allows attachment of various weapon accessories.

FRONT SIGHT ASSEMBLY (4) adjusts strike of bullet up or down.

BAYONET LUG (5) provides bayonet attachment.

EJECTION PORT COVER (6) prevents debris from entering chamber when closed. Keep closed when not firing.

MAGAZINE CATCH (7) locks magazine in place and also releases magazine from magazine well when depressed.

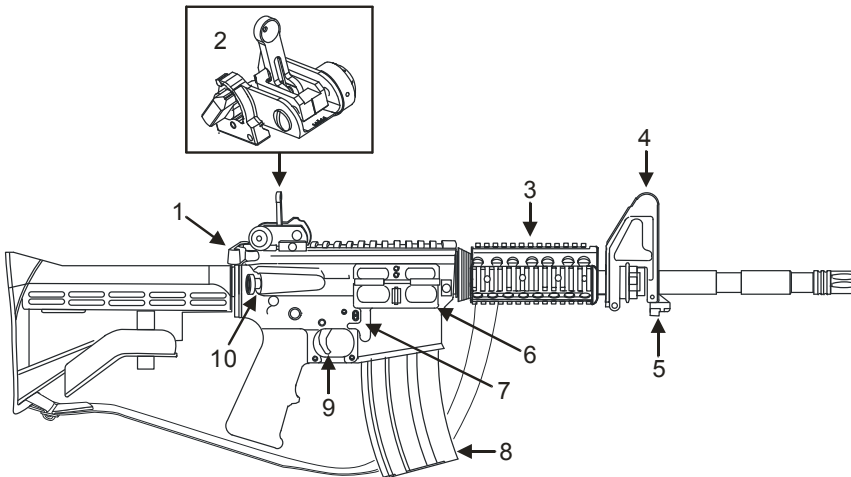

RIGHT VIEW M4/M4A1

MAGAZINE (8) holds 5.56mm ammunition.

TRIGGER (9) initiates firing sequence when squeezed.

FORWARD ASSIST ASSEMBLY (10) allows the operator to ensure the bolt is fully closed and locked.

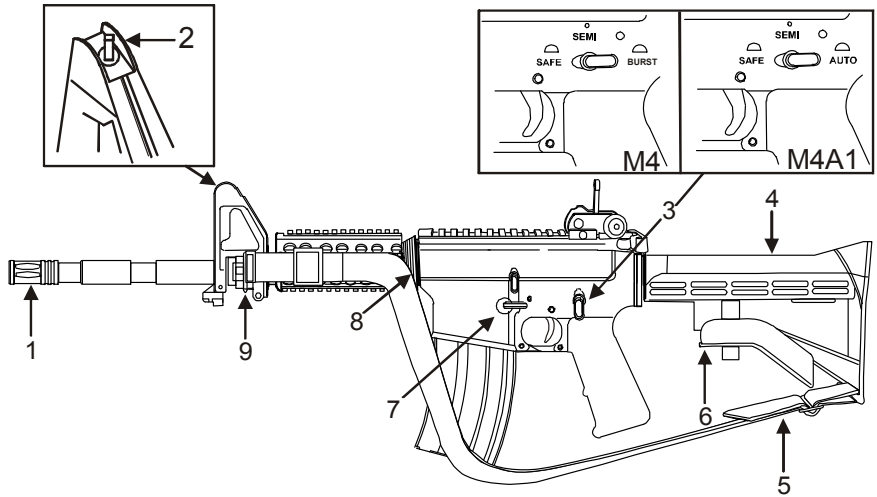

LEFT VIEW M4/M4A1

COMPENSATOR (1) helps prevent the muzzle from rising while firing.

FRONT SIGHT POST (2) adjusts strike of bullet up or down.

SELECTOR LEVER (3) selects mode of fire and places weapon on safe.

ADJUSTABLE BUTTSTOCK ASSEMBLY (4) houses spring and buffer assembly. Extends and collapses.

SLING (5) is an adjustable means to carry weapon.

LOCK/RELEASE LEVER (6) locks buttstock in extended or collapsed position. Releases buttstock to move from extended position to collapsed position.

BOLT CATCH (7) holds bolt to rear after firing last round.

SLIP RING (8) holds rail system in place.

SLING SWIVEL (9) attaches sling to weapon.

END OF WORK PACKAGE

OPERATOR

OPERATION UNDER USUAL CONDITIONS

INITIAL SETUP:
Not Applicable

Clearing Weapon

WARNING



The weapon **MUST** be cleared to be considered **SAFE** before disassembly, cleaning, inspecting, transporting or storing.

1. Point weapon in safe direction. Place selector lever on **SAFE**. If weapon is not cocked, lever can't be pointed toward safe.

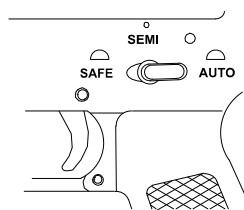

2. Remove cartridge magazine by depressing magazine catch button and pulling cartridge magazine down.

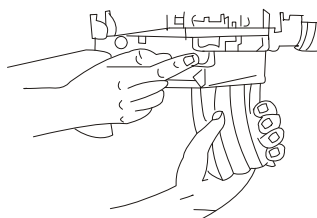

3. To lock bolt open, pull charging handle rearward. Press bottom of bolt catch and allow bolt to move forward until it engages bolt catch. Return charging handle to full forward position. Check receiver and chamber to ensure these areas contain no ammo.

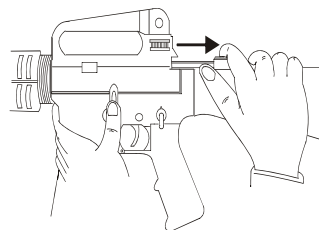

4. With selector lever pointing towards **SAFE**, allow bolt to go forward by pressing upper portion of bolt catch.

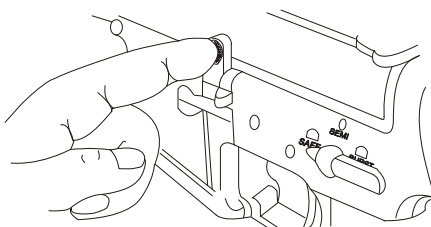

Firing Modes

WARNING



Weapon can chamber a round when dropped or jarred if loaded magazine is in place regardless of whether the bolt carrier assembly is in forward position or locked to the rear.

NOTE

Hammer must be cocked to place selector lever on **SAFE**.

1. Selector Lever Positions.

a. **SAFE**. Weapon will not fire. Always SAFE when loading and unloading

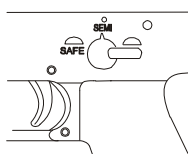

place on weapon.

b. **SEMI**. Weapon fires one round each trigger is pulled.

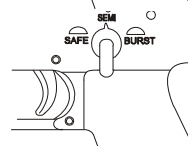

time the

c. **BURST**. (M16A2, M16A4, M4 only) three rounds each time the trigger is

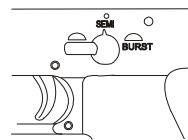

Weapon fires pulled.

d. **AUTO**. (M4A1 & M16A3 only). continue to fire as long as the trigger is

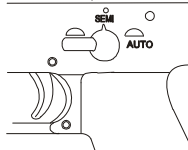

Weapon will being pulled.

Loading Weapon and Chambering Round.

NOTE

Magazine can be loaded with bolt assembly open or closed.

Loading Weapon – (**AIR FORCE ONLY**), Clear the weapon, close the bolt, close the ejection port cover and insert the magazine.

1. With hammer cocked, place selector lever **SAFE**. Point muzzle in safe direction.

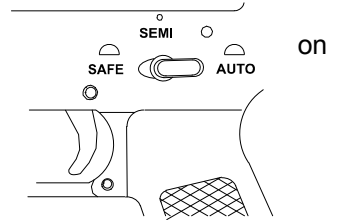

2. Open bolt and check chamber. Make sure it is clear. Press bottom of bolt catch and allow bolt to move forward until it engages bolt catch. Return charging handle to full forward position.

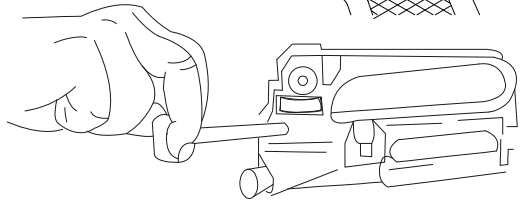

3. Push upward until magazine catch engages and holds magazine.

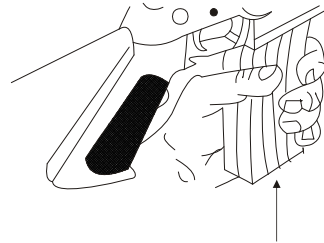

4. Tap upward to make sure it is seated correctly.

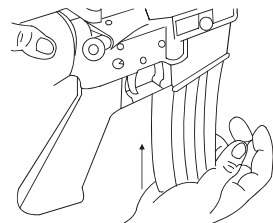

WARNING



Your weapon is now loaded. Ensure it is pointed in a **SAFE** direction.

5. Depress upper portion of bolt catch. Bolt should go forward.

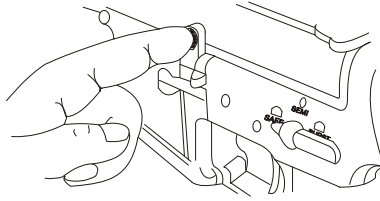

6. Tap forward assist to ensure bolt is fully forward and locked.

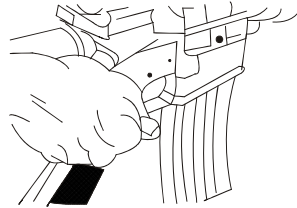

Chambering Round from Bolt Closed Position.

CAUTION

DO NOT ride the charging handle forward when chambering a round.

1. With magazine inserted, pull the charging handle all the way to the rear.
2. Release charging handle.
3. Tap forward assist to ensure bolt assembly is fully forward and locked.
(**AIR FORCE ONLY – not required step**)

Three Round Burst Control (M16A2, M16A4, M4 **ONLY**)

WARNING



STOP firing immediately if an audible “**POP**” is heard or reduced **RECOIL** is experienced while firing weapon. These could indicate an incomplete powder burn and/or a bullet stuck in the bore. Retract bolt slowly and remove fired cartridge case. Clear weapon and check for unburned powder grains in the receiver or bore and for a bullet stuck in the bore. Remove unburned powder or bullet from bore before resuming firing. If the bullet is stuck in bore, return the weapon to field maintenance.

WARNING

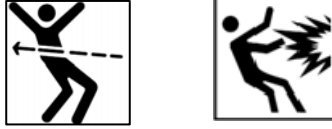

Ensure weapon is pointed in safe direction when loaded.

NOTE

When switching to **BURST** during fire, or changing magazine while firing in **BURST**, weapon may only fire 1 or 2 rounds on first trigger pull. The next trigger pull should fire 3 rounds.

NOTE

If the trigger is released before all three rounds have fired, the next pull of the trigger will only fire the one or two shots not fired in the previous trigger pull. A one or two shot **BURST** can also happen if firing is continued after changing magazines or switching from **SEMI** to **BURST**.

Follow these steps to ensure weapon fires 3 rounds on first trigger pull:

1. Ensure weapon is clear.
2. Place selector on **BURST**.
3. Pull trigger to rear and hold.
4. Pull charging handle and release three times.
5. Let go of trigger.

Three Round Burst Control (cont.)

6. Pull bolt to rear and press bottom of bolt catch to lock bolt to the rear.

7. Slide charging handle all the way forward.

8. Place selector lever on **SAFE**.

9. Insert a loaded magazine.

10. Push top of bolt catch to allow bolt to go forward.

11. Place selector lever on **BURST**.

12. Pull trigger and hold until all three rounds have fired.

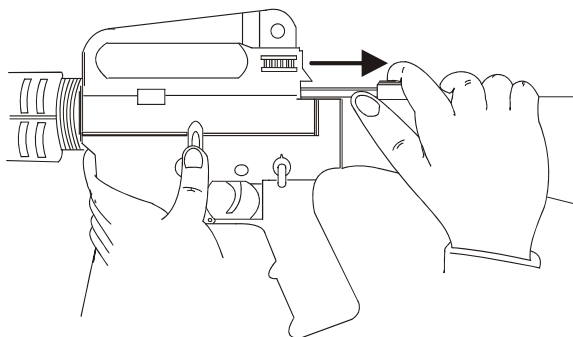

Immediate Action – If your weapon stops firing, perform the following immediate actions:

WARNING



STOP firing immediately if an audible “**POP**” is heard or reduced **RECOIL** is experienced while firing weapon. These could indicate an incomplete powder burn and/or a bullet stuck in the bore. Retract bolt slowly and remove fired cartridge case. Clear weapon and check for unburned powder grains in the receiver or bore and for a bullet stuck in the bore. Remove unburned powder or bullet from bore before resuming firing. If the bullet is stuck in bore, return the weapon to field maintenance.

Perform following immediate action when weapon stops firing.

1. Slap upward on magazine to make sure it is properly seated.

2. Pull charging handle all the way to the rear.

3. Observe for ejection of case or cartridge.

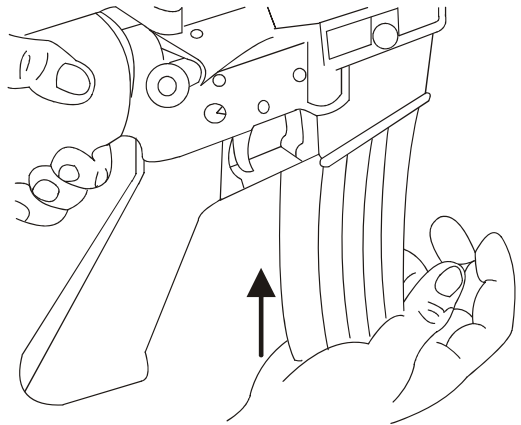

4. If cartridge or case is ejected or chamber is clear, release charging handle to feed new round. **DO NOT** ride the charging handle forward.

Immediate Action (cont.)

5. Push the forward assist.
6. Squeeze trigger and weapon should **FIRE**.
7. If weapon still does not fire, apply remedial action.

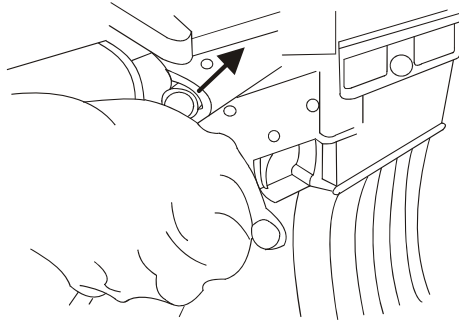
**Remedial Action****WARNING**

If weapon stops firing with a live round in the chamber of a hot barrel, remove the round quickly. However, if you cannot remove it within 10 seconds, remove magazine and wait 15 minutes with the weapon pointed in a safe direction. This will avoid injury during possible cookoff. **ALWAYS** keep face away from the ejection port when clearing a hot chamber.

1. If your weapon still fails to fire after performing immediate action, check again for jammed cartridge case.

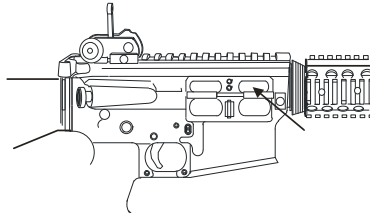

2. If a cartridge case is still in the chamber, tap it out with a cleaning rod.

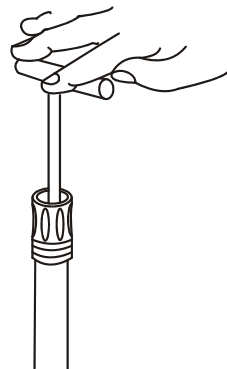

Bullet Stuck In Bore

WARNING



STOP firing immediately if an audible “**POP**” is heard or reduced **RECOIL** is experienced while firing weapon.

DO NOT APPLY IMMEDIATE ACTION

1. Remove the magazine.
2. Pull bolt to rear and press bottom of bolt catch to lock bolt to the rear.
3. Place the selector lever on **SAFE**.
4. Visually inspect chamber to see if it is clear.
5. Insert cleaning rod into the bore to ensure there is not a bullet stuck in the bore.
6. **DO NOT** attempt to remove a bullet stuck in the barrel of a weapon; turn the weapon in to field maintenance.

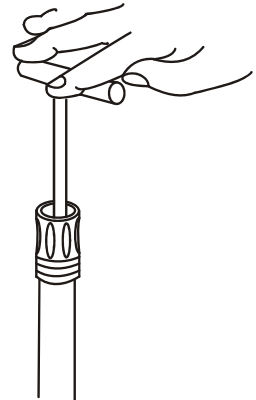

Loading Magazine

NOTE

Magazines can be loaded quickly using ten-round stripper clips and the magazine filler found in each bandoleer.

1. Place the magazine filler in the magazine.



2. Place a ten round stripper clip in the magazine filler.

3. Using thumb pressure on the rear of the top cartridge, press down firmly until all ten rounds are below the feed lips of the magazine.

4. Remove the empty stripper clip while holding magazine filler in place.

5. Repeat until three ten-round clips are loaded.

6. Remove magazine filler and retain it for future use.

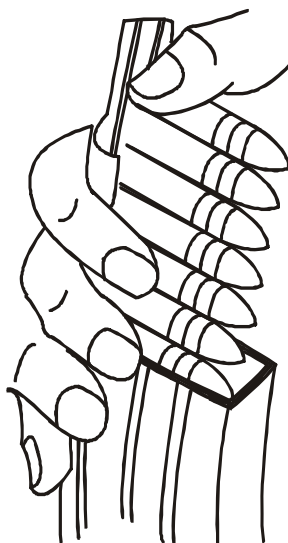

END OF WORK PACKAGE

OPERATOR**OPERATIONS UNDER UNUSUAL CONDITIONS**

INITIAL SETUP:**Tools:**

Lubricant Oil
for Arctic Weapons (LAW)
(WP0022)
CLP Lubricant (WP0022)
Muzzle Cap
Magazine Bag
Weapon Cover

References:

PMCS Table WP0006
FM 3-3
FM 3-100
Lubrication Instructions WP0016

Equipment Condition

Cold, Hot, Dry, Wet
depending upon
climate conditions

Extreme Cold Climate – Arctic**NOTE**

A small amount of CLP on moving parts can freeze and prevent weapon from firing in extreme cold conditions. Thoroughly remove CLP from weapon and apply LAW for operations in extreme cold weather (See Lubrication Instructions WP 0016)

Operation. To operate weapon in extreme cold, depress trigger guard plunger and open the trigger guard to allow for easy access to the trigger while wearing arctic mittens.

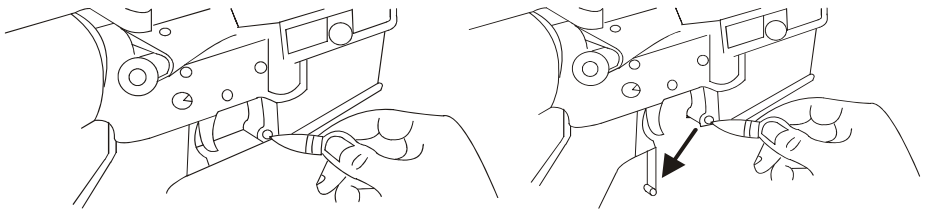

Cleaning and Lubrication. Clean and lubricate weapon in warm room with weapon at room temperature if possible.

1. Apply a light coat of Lubricating Oil for Arctic Weapons (LAW) to all functional parts.
2. Keep weapon covered when moving from warm to cold areas to prevent condensation and/or freezing. Allow weapon to cool gradually when possible.
3. Keep weapon dry whenever possible.
4. Unload and perform function check every 30 minutes to help prevent freezing of functional parts.
5. **DO NOT** lay warm weapon directly on ice or in snow.
6. Condensation will form on weapon when moved from a cold area to a warm area. Weapon should be disassembled and wiped dry several times as it warms to room temperature.
7. Keep ammunition and the insides of magazines wiped dry. Moisture will freeze and cause weapon malfunction.
8. **DO NOT** lubricate ammunition.
9. Use muzzle cap, protective magazine bag, and weapon cover to protect weapon in extreme cold weather whenever the tactical situation permits.
10. Field maintenance should remove trigger guard for extended operations in extreme cold weather.

Hot, Wet Climate – Jungle

NOTE

Use magazine bag, muzzle cap or rifle cover for protection when the tactical situation permits.

1. Perform normal maintenance as outlined in the PMCS table (WP 0012).
2. Clean and lubricate with CLP more frequently than normal.
3. Inspect all parts of the weapon for corrosion more frequently and more completely than normal.
4. Remove handprints from weapon with dry rag and lubricate lightly with CLP.
5. Unload and check inside magazines for corrosion and moisture frequently. Ensure ammunition is dry before reloading magazines.

Hot, Dry Climate – Desert

NOTE

Deserts are usually areas containing blowing sand and fine dust. Deserts can be hot during daylight hours and cold during the night. The harsh environment will severely tax weapons and other equipment. Consistent operation of weapons depends on following detailed cleaning and lubricating procedures outlined in PMCS table.

Use magazine bag, muzzle cap or rifle cover for protection when the tactical situation permits.

Hot, Dry Climate – Desert (cont.)

1. Clean inside and functional areas of the weapon every day and after firing missions in desert environments. Dust and sand will get into the weapon and magazines and cause malfunctions.
2. In a desert environment, generous amounts of lubrication should be applied to the internal working surfaces and functional parts of the weapon only. Unload and dry ammunition and the inside of magazines daily. **DO NOT** lubricate magazines.
3. Keep the bolt and ejection port cover closed, magazine in the magazine well, and muzzle cap on to keep sand and dust out of the weapon.

Heavy Rain and Water Crossing – All Climates**NOTE**

Use magazine bag, muzzle cap or rifle cover for protection when the tactical situation permits.

1. Perform regular maintenance according to PMCS table.
2. **ALWAYS** attempt to keep weapon dry.
3. **ALWAYS** drain water from barrel before firing. Dry the bore with a swab and cleaning rod if wet.

After Water Crossing

WARNING

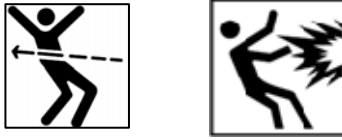

DO NOT fire if water is present in barrel.

1. Remove muzzle cap.
2. Point weapon downward and shake vigorously.
3. Pull charging handle 2 to 3 inches rearward and allow water to drain.
4. Release charging handle and tap forward assist to seat round and lock bolt.
5. Clear the drain hole in the stock with a pipe cleaner and drain.

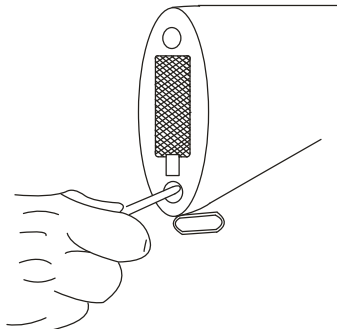

After Salt Water Operations

1. Clean rear sight as soon as possible if saltwater is on it.
2. Wash rear sight with fresh water, from canteen or other fresh water source, if situation does not permit using CLP.

Nuclear, Biological, and Chemical (NBC)

General procedures can be found in FM 3-3, FM 3-5, and FM 3-100.

END OF WORK PACKAGE

OPERATOR**FUNCTION CHECK**

INITIAL SETUP:

Not Applicable

WARNING

ALWAYS clear weapon before starting a function check.
DO NOT squeeze trigger until weapon has been cleared.

1. Remove magazine and check chamber. Always check chamber to ensure it is empty and no ammunition is in position to be chambered.
2. Perform function check.
 - a. Place selector lever on **SAFE**: Pull and release charging handle. Pull trigger. Hammer should not fall.

NOTE

Slow is defined as $\frac{1}{4}$ to $\frac{1}{2}$ the normal rate of trigger release.

- b. **SEMI**: Place selector lever on **SEMI**. Pull trigger. Hammer should fall. Hold trigger to the rear and charge the weapon. Release the trigger with a slow, smooth motion, until the trigger is fully forward (an audible click should be heard). Pull trigger. Hammer should fall.

c. **BURST:** (M16A2, M16A4, M4 **ONLY**) Place selector lever on **BURST**. Charge weapon and squeeze trigger. Hammer should fall. Hold trigger to the rear, pull the charging handle to the rear and release 3 times. Release trigger. Squeeze trigger. Hammer should fall.

d. **AUTO:** (M16A3, M4A1 **ONLY**) Pull the charging handle to the rear, charging the weapon. Squeeze the trigger, hammer should fall. Hold the trigger to the rear, and cock the weapon again. Fully release the trigger then squeeze the trigger again. The hammer should not fall because it should have fallen when the bolt was allowed to move forward during the chambering and locking sequences.

END OF WORK PACKAGE

OPERATOR

25 METER ZEROING

INITIAL SETUP:
Not Applicable

Adjustable Rear Sight. Two apertures for different ranges.

Short Range or at Night. Larger aperture sight used for 0-200 meter range, night, and moving targets. Elevation knob is all the way down when using larger aperture sight.

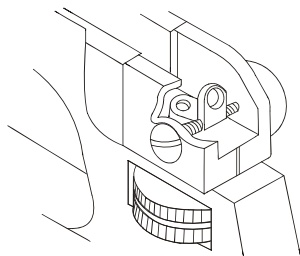

(0-200 meters)

Normal Range. Smaller aperture sight used for most firing situations. Used with elevation knob for 300-800 meter range.

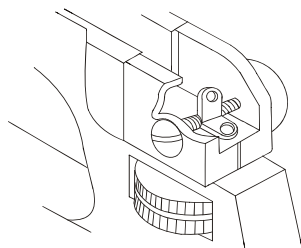

(300-800 meters M16A2/A3)
(300-600 meters M4/M4A1/M16A4)

Battlesight Zero

When battlesights are on your weapon:

1. The front sight past and rear windage knob are adjusted so you can hit your point of aim at 300 meters.
2. The unmarked aperture must be in the up position.
3. The 300-meter mark is aligned with the mark on the left side of the receiver. This will read 8/3 for the M16A2/M16A3 and 6/3 for the M4/M4A1/M16A4.

Battlesight Zeroing Adjustments

1. During zeroing procedures, only the front sight post and windage knob are adjusted to move the strike of the bullet on the target.
2. If you are zeroing on a 25-meter range, the rear sight elevation knob is adjusted in accordance to whichever weapon you are using.
3. Detailed zeroing procedures are on the target and the following pages.

Front Sight – The front sight post is moved up or down when zeroing the weapon. **Once the weapon is zeroed, the front sight post should NOT be moved.**

To adjust elevation, depress detent and rotate post. To raise strike of bullet, rotate post in the direction of arrow marked UP. Reverse the direction of rotation to lower strike of bullet. Each graduation (notch) moves the point of impact of bullet as indicated.

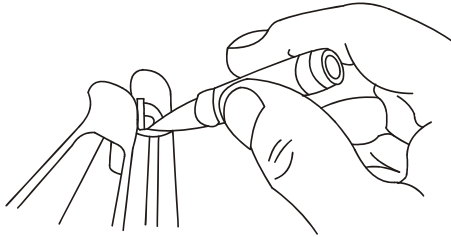

FOR ELEVATION (per click)

Impact		Distance	(M16A2/M16A3/M16A4)
0.9 cm	(3/8 in)	25 meters	
3.5 cm	(1 3/8 in)	100 meters	
7.0 cm	(2 3/4 in)	200 meters	

FOR WINDAGE KNOB (per click)

Impact		Distance	(M16A2/M16A3/M16A4)
0.3 cm	(1/8 in)	25 meters	
1.25 cm	(1/2 in)	100 meters	
2.60 cm	(1 in)	200 meters	
3.8 cm	(1 1/2 in)	300 meters	
5.0 cm	(2.0 in)	400 meters	
6.3 cm	(2 1/2 in)	500 meters	
7.8 cm	(3 in)	600 meters	
8.8 cm	(3 1/2 in)	700 meters	
10.0 cm	(4 in)	800 meters	

FOR ELEVATION (per click)

Impact	Distance (M4/M4A1)
1.2 cm (1/2 in)	25 meters
4.8 cm (1 7/8 in)	100 meters
9.6 cm (3 3/4 in)	200 meters

FOR WINDAGE KNOB (per click)

Impact	Distance (M4/M4A1)
0.5 cm (3/16 in)	25 meters
1.9 cm (3/4 in)	100 meters
4.8 cm (1 1/2 in)	200 meters
5.7 cm (2 1/4 in)	300 meters
7.6 cm (3 in)	400 meters
9.5 cm (3 3/4 in)	500 meters
11.4 cm (4 1/2 in)	600 meters

To remember your correct battlesight zero windage, note location of windage scale and windage knob pointer (heavy mark on outside of knob).

Do not center rear sight aperture for inspections. Keep your correct battlesight zero windage on your weapon at all times.

By following the steps below and establishing a zero at 25 meters, your sights will be set with a 300-meter battlesight.

NOTE

DO NOT move front sight post at this time. It was set at the factory or by a previous shooter and should be very close to your zero.

Center the rear sight aperture by turning the windage knob left or right. (This is called mechanical zero windage.)

Setting Battlesight Zero

1. Position a 25 Meter Zero Target (NSN 6920-01-395-2949), 25 meters from firing line. The rifle target is on one side and the carbine target is on the other.
2. The unmarked long range aperture should be up.
3. Rotate elevation knob in the down direction, counter-clockwise. The elevation knob should stop on the 300-meter mark 8/3 on the M16A2/M16A3 and 6/3 on the M16A4/M4/M4A1. The rear sight should be all the way down on the last whole "click" before it bottoms out. This is mechanical zero for the rear sight.

NOTE

Take weapon to field maintenance if rear sight elevation does not line up with mechanical zero. 8/3 on the M16A2/M16A3 or 6/3 on the M16A4/M4/M4A1.

4. Rotate the elevation knob clockwise one click up past the mechanical zero setting for the M16A2/M16A3 and two clicks up for the M16A4. The M4/M4A1 carbine should stay at the mechanical zero. Any further corrections required in elevation are made to the front sight post only.
5. Aim at target center. Adjust front sight and rear windage to move shot group center as close as possible to the white dot in the center of target.
6. If your shot group is not in the center of the bull's eye, use the squares on the target sheet to calculate the required "clicks necessary to move you next shot group into the bull's eye. Remember, any changes in elevation are made by moving the front sight post. The squares are numbered around the edges of the target to equal the number of clicks required to move the shot group to the bull's eye.
7. In order to raise you next shot group, rotate the front sight post clockwise. One click will move the strike of the bullet one vertical square on the target sheet. In order to lower your next shot group, rotate the front sight post counterclockwise, one click equals one square. Changes in windage are made with the windage knob. Three clicks will move the strike of the bullet one horizontal square on the target sheet. In order to move the shot group to the left, turn the windage knob counterclockwise. In order to the shot group to the right, turn the windage knob clockwise.
8. Carefully aim and fire another group at the center of the target bull's eye.
9. Repeat Steps 6 through 8, if required.
10. If your group is center, your weapon is now zeroed.

RIFLES ONLY

11. Rotate the rear sight elevation knob counterclockwise, down, one click to the 300-meter setting for the M16A2/M16A3 Rifle, down two clicks to the 300-meter setting for the M16A4 Rifle. The weapon is zeroed for 300 meters.

Zeroing with Back-Up Iron Sight

1. To zero the M4/M4A1 Carbine, the line on the sight cam on the left side needs to align with the 300-meter mark. Use the 25 meter zero target for the M4 Carbine and center your rounds by adjusting the weapon's front sight post and the BUIS windage adjustment knob.

2. To zero the M16A4 Rifle, the line on the left side of the sight cam needs to align with the white line between the 300-400 meter zero target marks. The mark may be difficult to align as it is a half notch location. Use the 25 meter zero target for the M16A4 Rifle and center your rounds by adjusting the weapon's front sight post and the BUIS windage adjustment knob.

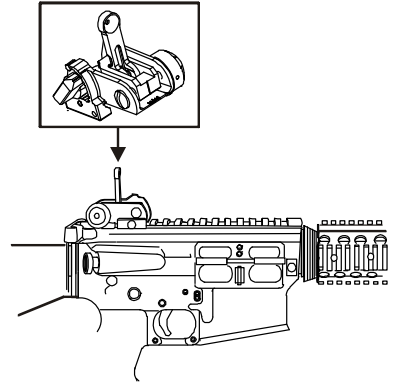

END OF WORK PACKAGE

OPERATOR
INSTALLATION OF EQUIPMENT

INITIAL SETUP:

Equipment Required
M15A2 Blank Firing Attachment
M23 Blank Firing Attachment
Top Sling Adapter
Swivel Mount
Vertical Pistol Grip

M15A2/M23 Blank Firing Attachment(BFA)

WARNING



ALWAYS clear weapon before installation of blank firing attachment.

DO NOT fire directly at anyone less than 20 feet away when using the blank firing attachment.

Blank firing attachment is used only with M200 blank 5.56mm round.

CAUTION

DO NOT use tools to tighten attachment. Hand tighten only.

NOTE

Clean carbon buildup after every use.

Check BFA for tightness after 50 rounds.

CAUTION

M23 BFA: Painted yellow, stamped "M4 Carbine Only," for use with M4 and M4A1 Carbines.

M15A2 BFA: Painted red, for use with M16A2/M16A3/M16A4.

1. Unscrew and pull BFA slide all the way out.

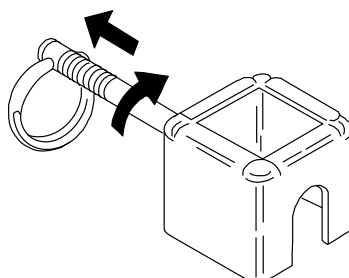

2. Slide BFA over compensator of weapon. Hook arc opening of BFA behind first groove of compensator.

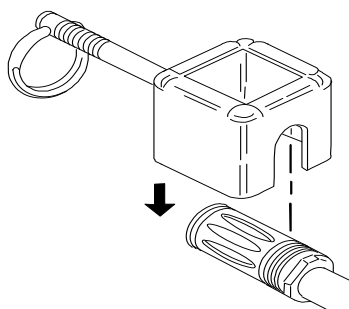

3. Screw BFA slide into compensator and **HAND TIGHTEN.**

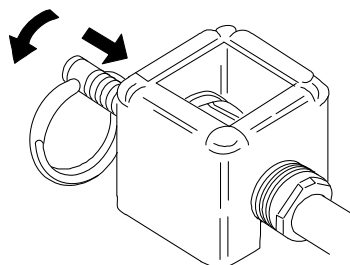

Top Sling Adapter

WARNING

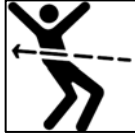

ALWAYS clear weapon before installing top sling adapter.

1. Rifle only: Install top sling adapter strap through sling swivel and tie.

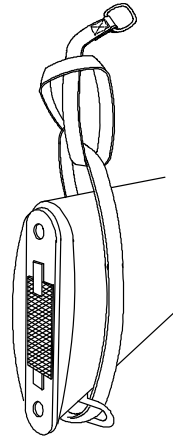

RIFLE

2. Carbine only: Install top sling adapter strap through sling opening and tie.

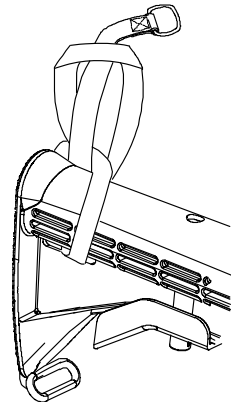

CARBINE

NOTE

Item 1a shows alternate carbine buttstock with alternate sling opening.

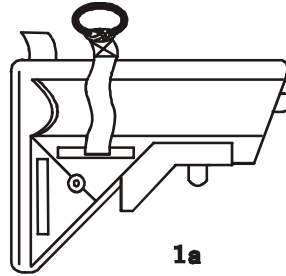

3. Work the clamp on to the front sight base (1) and spin so the loop is outward (2).

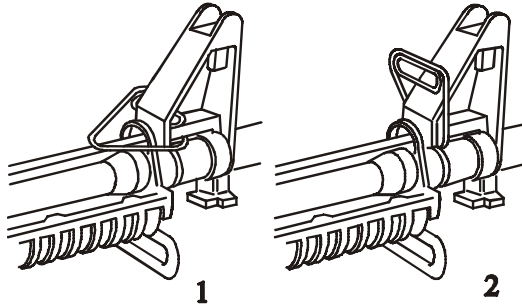

4. Loop sling through the sling adapter strap (1) in the rear and clamp(2) in the front. Tighten sling.

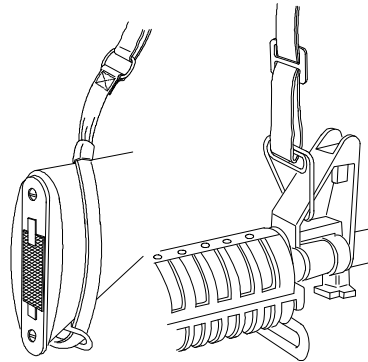

Remove Top Sling Adapter

1. Remove sling from clamp and top sling adapter strap.
2. Use pliers to remove clamp from front sight base.
3. Untie top sling adapter strap and remove from buttstock.
4. Install sling in normal configuration.

Swivel Mount

The standard side sling adapter must be positioned so the sling swivel is to the right side of the weapon in accordance with Army TM 9-1010-221-23&P, and Navy SW 370-AE-MMI-010, Maintenance Manual for M203 Grenade Launcher. The side sling adapter should be attached with the integral stop to the rear allowing the swivel to fold towards the compensator. This will allow accessories to be installed on the rails of the weapon.

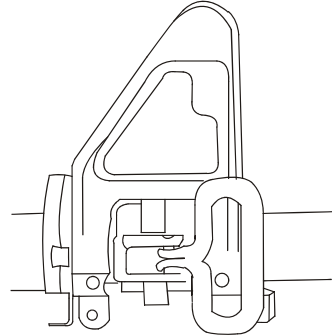

Vertical Pistol Grip

1. Detach rail cover from rail where the pistol grip will be installed.
2. Unscrew pistol grip lock in bottom of pistol grip until the upper tip rests below the surface.

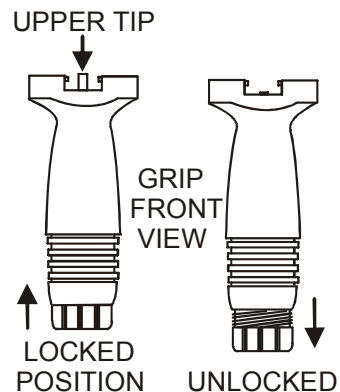

3. Slide the pistol grip on to the adapter rail.

NOTE

Align the upper tip of the pistol grip with a rail slot so the pistol grip can be properly tightened on the adapter rail and the upper tip does not get damaged.

4. Hand tighten the pistol grip on to the adapter rail. Look through the observation holes in the pistol grip to ensure the upper tip is in a rail groove before tightening.

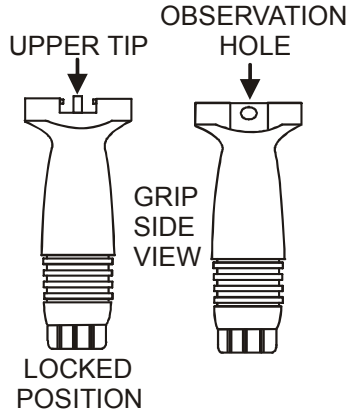

5. Install the proper sized rail covers for use with the vertical pistol grip.

a. Rifle: Install 9-rib rail cover, then vertical pistol grip, and then a 6-rib cover on the lower adapter rail. Pistol grip can also be installed on the muzzle end of the rail.

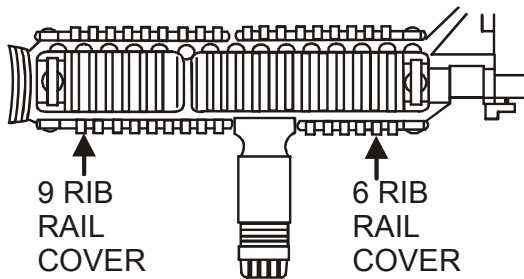

b. Carbine: Install 6-rib rail cover and then the vertical pistol grip on the lower adapter rail.

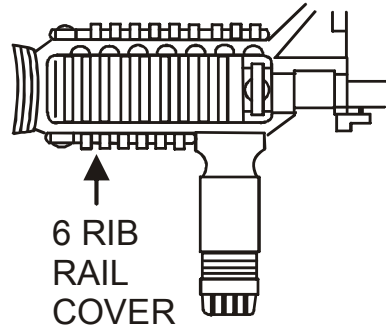

NOTE

Rail covers will only lock into the end slots on the rails.

6. When installing pistol grip in different positions, experiment with different lengths of rail covers around the pistol grip to fully cover and protect the rail surface and keep the operator's hand from contact with metal parts of the rail.

Cleaning and Inspection of the Vertical Pistol Grip

Weekly cleaning:

1. Remove pistol grip from rail. Unscrew pistol grip lock on bottom of pistol grip until upper tip disengages from rail slot. Slide pistol grip off rail towards the muzzle.
2. Clean the lock and base (including internal threads). Clean rail surface under the pistol grip and rail covers.
3. Lightly lubricate the rail surfaces but not the pistol grip. The shaft and threads of the pistol grip are self lubricating and should not require lubrication.

END OF WORK PACKAGE

CHAPTER 3
OPERATOR TROUBLESHOOTING
PROCEDURES

OPERATOR
TROUBLESHOOTING

INITIAL SETUP:**References**

WP0004
WP0006
WP0008
WP0009
WP0010

Equipment Conditions

Misfire procedures have
been performed WP0008

WARNING

Keep clear of muzzle when inspecting malfunctions.

Introduction

Table 1 lists common malfunctions. Perform tests, inspections, and corrective actions in same order as they appear in the table.

NOTE

This table cannot list all malfunctions that may occur or all tests and inspections to be completed, or all the corrective actions that may be needed. Notify the Field Maintenance for all equipment malfunctions not listed or if corrective actions do not fix malfunction.

Table 1. TROUBLESHOOTING

MALFUNCTION	TEST OR INSPECTION	CORRECTIVE ACTION
Will Not Fire	Selector Lever on SAFE	Place Selector Lever in Firing Position
	Improper Assembly of Firing Pin	Assemble Firing Pin Correctly with Retaining Pin Behind Large Shoulder of Firing Pin
	Excess Oil in Firing Pin Recess	Clean Firing Pin Recess
	Excess Carbon on Firing Pin or in Recess	Clean Firing Pin and Recess
	Defective Ammunition	Discard and Replace Ammunition
	Light Indentation on Round Primer	Notify Field Maintenance
Bolt Will Not Unlock	Dirty or Burred Bolt	Notify Field Maintenance
Will Not Feed	Dirty or Corroded Ammunition	Clean or Replace Ammunition
	Dirty Magazine	Clean Magazine
	Defective Magazine	Replace Magazine
	Overloaded Magazine	Remove Excess Rounds
	Buffer Assembly Action is Restricted	Clean Buffer and Spring
	Magazine Not Fully Seated	Tap on Magazine or Adjust Magazine Catch

Table 1. TROUBLESHOOTING (cont.)

MALFUNCTION	TEST OR INSPECTION	CORRECTIVE ACTION
Double Feed	Defective Magazine	Replace Magazine
Round Will Not Chamber	Dirty or Corroded Ammunition	Clean or Replace Ammunition
	Damaged Ammunition	Replace Ammunition
	Carbon in Chamber or Gas Tube	Clean Chamber or Gas Tube
Bolt Will Not Lock	Dirt, Corrosion, or Carbon in Barrel or Bolt Locking Lugs	Clean Bolt Locking Lugs
Bolt Will Not Extract Round	Frozen Extractor	Remove Bolt and Clean Extractor
	Restricted Buffer Assembly	Clean Buffer and Spring
	Restricted Movement of Bolt Carrier Group	Remove, Clean, and Lubricate Bolt (Ensure gas tube fits into carrier key and moves freely)
	Dirty or Corroded Ammunition	Clean or Replace Ammunition
	Dirty Chamber	Clean Chamber
	Cartridge Stuck	Push Cartridge Out with Cleaning Rod
	Broken Extractor Spring	Notify Field Maintenance
Short Recoil	Gaps in Bolt Rings Not Staggered	Spin Bolt Rings to Stagger Gaps
	Carbon or Dirt in Carrier Key or on Gas Tube	Clean Carrier Key and Gas Tube
	Broken or Missing Bolt Rings (3 rings required)	Notify Field Maintenance
	Pipe Cleaner Stuck in Carrier Key	Notify Field Maintenance

Table 1. TROUBLESHOOTING (cont.)

MALFUNCTION	TEST OR INSPECTION	CORRECTIVE ACTION
Bolt Fails to Lock After Last Round	Dirty or Corroded Bolt Latch	Clean Bolt Latch
	Faulty Magazine	Replace Magazine
Selector Lever Binds	Overly Dry Selector Lever	Lubricate Selector Lever
	Dirt or Sand Under Trigger	Clean Trigger Assembly
Bolt Carrier Hung Up	Round Jammed Between Bolt and Upper Receiver and/or Double Feed CAUTION Bolt May Slam Forward When Removing Rounds	Remove Magazine, Remove Rounds, Notify Field Maintenance if Rounds can't be Removed

END OF WORK PACKAGE

CHAPTER 4

**OPERATOR MAINTENANCE
INSTRUCTIONS**

OPERATOR**PREVENTIVE MAINTENANCE CHECKS
AND SERVICES (PMCS)**

GENERAL

Perform preventive maintenance procedures in accordance with PMCS Table prior to each mission to ensure the readiness of the weapon. Preventive maintenance procedures include inspection, cleaning, and performance of the checkout procedures.

EXPLANATION OF TABLE ENTRIES

Item Number Column. Numbers in this column are for references. Include the item number of the check/service that indicates a fault when completing the Equipment Inspection and Maintenance Worksheet. Item numbers must also appear in the order that checks and services are completed for the intervals listed.

Interval Column. This column states the time intervals to complete the procedures. BEFORE (B) procedures must be completed before operating weapon for its intended use. DURING (D) procedures must be completed while operating the weapon. AFTER (A) procedures must be done immediately after operating the weapon.

Item to be Checked or Service Column. This column provides the part of the weapon to be checked or serviced.

Equipment Not Ready/Available Column.

DO NOT operate weapon if faults in this column are present. Faults in this column indicate the weapon is not mission capable. Follow standard procedures for reporting or servicing equipment.

WARNING



The weapon **MUST** be cleared before inspecting, cleaning, disassembly, transporting, or storing to be considered **SAFE**.

NOTE

An inactive weapon is a weapon stored in an arms room for a period of 90 days or more. PMCS must be performed on all inactive weapons every 90 days.

Table 1. Preventative Maintenance Checks and Services (PMCS)

Item	Interval	Item Checked/ Serviced	Procedure	Equipment Not Ready/Available
1	Before	Magazine	Slips easily into magazine well. Locks in place.	Magazine is distorted, hard to seat, does not lock in place.
	Before	Magazine	Magazine follower moves easily/spring has tension.	Magazine follower is stuck/spring is weak.
2	Before	Upper Receiver/ Barrel	Check barrel looseness (hand pressure only)	Barrel loose
3	Before/ During	Detachable Carrying Handle (M16A4/M4/M4A1 if present)	Check for missing/damaged parts Ensure handle mounts to rail. Hand tighten handle nuts.	Handle missing, damaged, or will not mount on rail.
4	Before	Sights (Zero adjustment)	Check sights for adjustment/ movement. Return sights to zero setting after check.	Sights damaged, missing, or can not be adjusted.
5	Before	Magazine Catch	Catch should hold magazine in place/ release magazine when pushed.	Catch does not hold magazine in place/ release magazine when pressed.
			Pressing the magazine catch button should release the magazine. To adjust the magazine catch, use cleaning rod to press in on the magazine catch button until the left side of the magazine sticks out beyond the receiver. To tighten, turn the magazine catch clockwise; to loosen, turn it counterclockwise.	

**Table 1. Preventative Maintenance Checks and Services (PMCS)
cont**

Item	Interval	Item Checked/ Serviced	Procedure	Equipment Not Ready/Available
6	Before	Visual Inspection of entire weapon	Look for missing or damaged parts. Report missing or damaged parts to field maintenance.	Parts are missing or damaged to a point of being unserviceable.
7	During	Periodic Inspection of entire weapon	Make sure weapon is clean and bore is free of foreign material. (Refer to WP 0014 to clean bore if foreign material is present in bore.)	Foreign material found in bore.
8	During	Service during firing.	Clean and lubricate weapon after firing approx. 200 rounds or at end of day.	
9	After	Service weapon/equipment	Disassemble weapon and magazine. Clean and lubricate both. Refer to Chapter 3 for instructions. Report any damaged or missing parts to field maintenance.	Parts are missing or damaged to a point of being unserviceable.
10	Before/ After		Perform Function Check (Refer to WP 0008).	Weapon fails function check.

END OF WORK PACKAGE

OPERATOR
DISASSEMBLY INSTRUCTIONS

INITIAL SETUP

Not Applicable

WARNING

The weapon **MUST** be cleared before inspecting, cleaning, disassembly, transporting, or storing to be considered **SAFE**.

1. Clear the weapon (WP 0006).
2. Remove sling
3. Remove handguards (3a) or lower adapter rail (3b).

CAUTION

DO NOT use a screwdriver or any other tool when removing handguards/lower rail as it may cause damage to the handguards/lower rail and/or slip ring.

3a. Handguards: Place the weapon on the buttstock and press down on the slip ring with both hands. Using the "buddy system", have another person pull the handguards free.

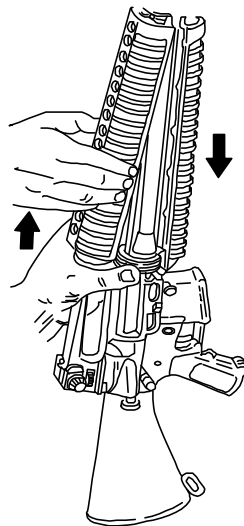

3b. Lower Adapter Rail: Place the weapon on the buttstock and press down on the slip ring. Pivot lower rail away from weapon. Pull lower rail back out of the forward handguard cap.

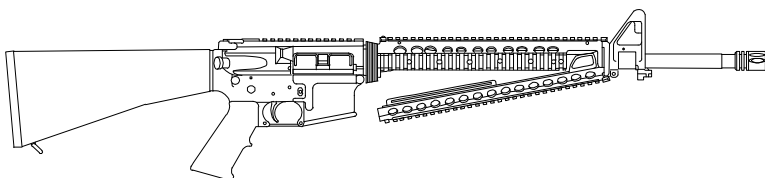

NOTE

The operator is only authorized to remove the lower adapter rail and rail covers for cleaning, lubrication, or attaching accessories.

The adapter rails for the M16A4 rifle and M4 carbine series will replace the handguards.

4. Push takedown pin as far as it will go. Pivot upper receiver from lower receiver.

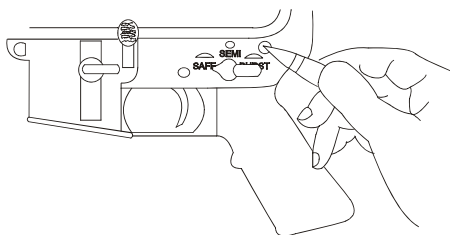

5. Push receiver pivot pin as far as it will go.

6. Separate upper and lower receivers.

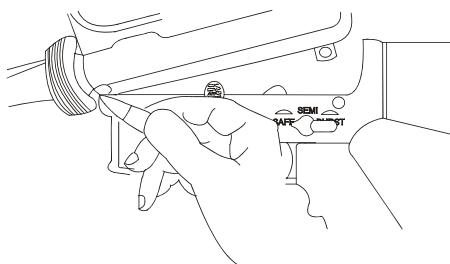

7. Remove carrying handle if applicable. Loosen the screws on the left side of the clamping bar. The handle will lift off easily once the clamping bar is loose.

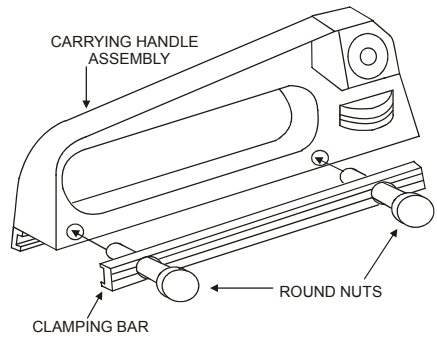

8. Pull back charging handle and bolt carrier.

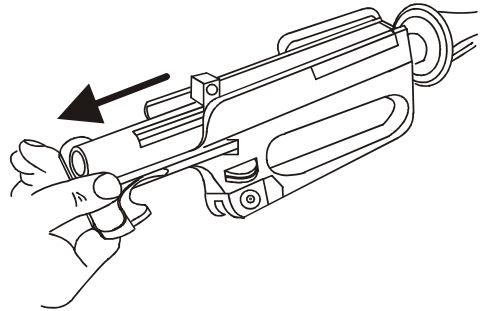

9. Remove bolt carrier and bolt.

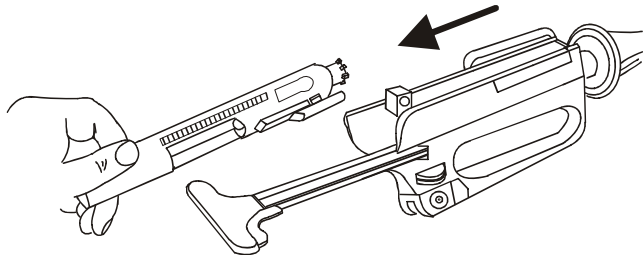

10. Remove charging handle.

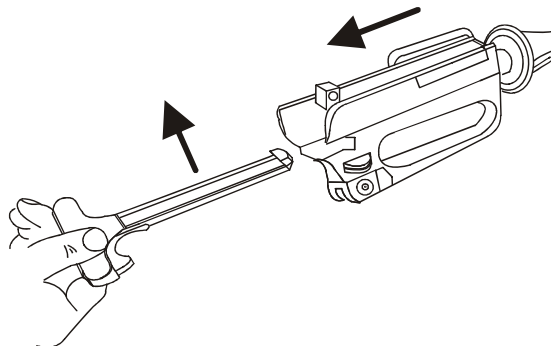

11. Remove firing pin retaining pin.

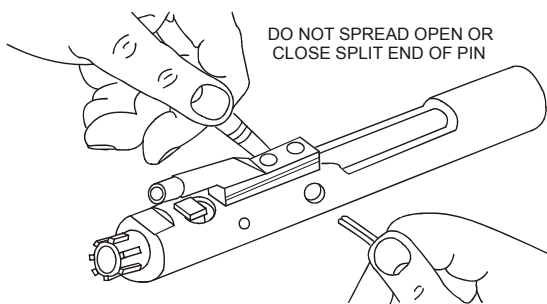

12. Push in bolt assembly to locked position.

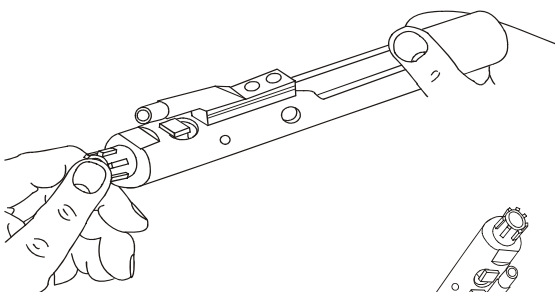

13. Drop firing pin out of rear of bolt carrier.

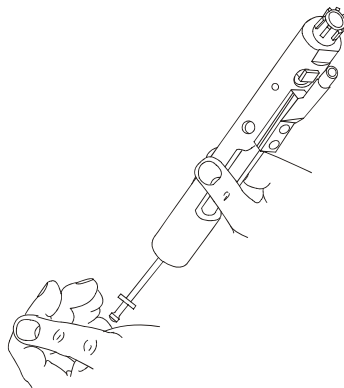

14. Remove bolt cam pin.

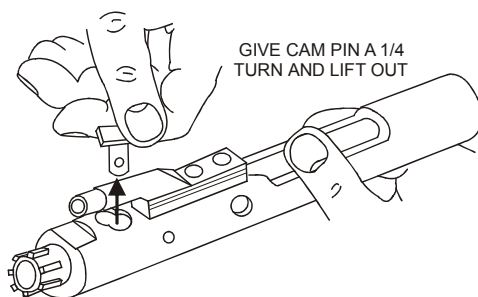

15. Remove bolt assembly from carrier.

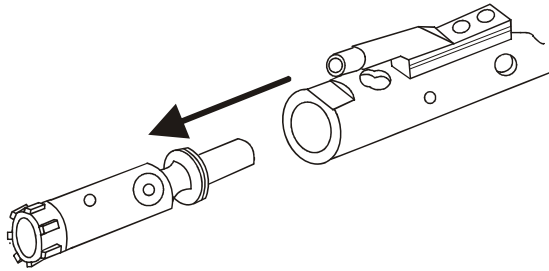

NOTE

Disassemble using steps 16 thru 22 only when dirty or damaged.

16. Remove extractor pin.

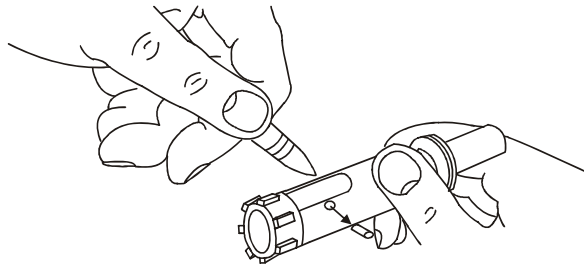

NOTE

Press rear of extractor before removing to check spring function. Notify Field Maintenance if spring is weak.

17. Remove extractor and spring assembly.

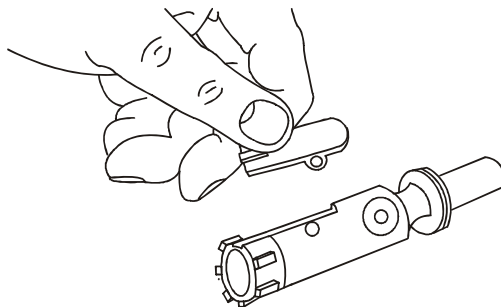

NOTE

DO NOT separate spring assembly from extractor.

18. Press in buffer, depress retainer, and release buffer.

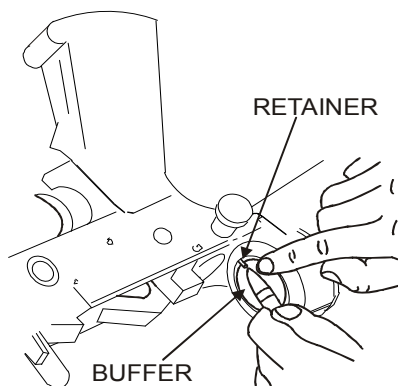

19. Remove buffer and action spring.

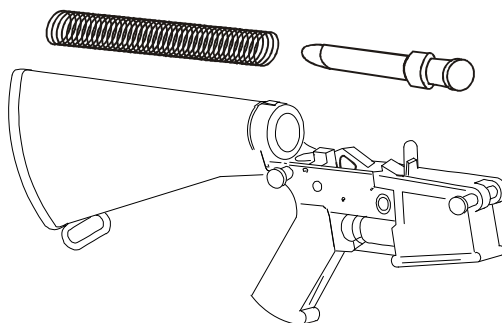

CARBINE ONLY

20. Fully extend buttstock assembly.

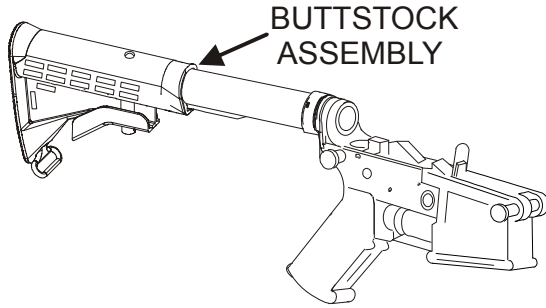

21. Grasp the lock release lever in the area of the retaining nut, pull downward and slide buttstock to the rear to separate the buttstock assembly from the lower receiver extension.

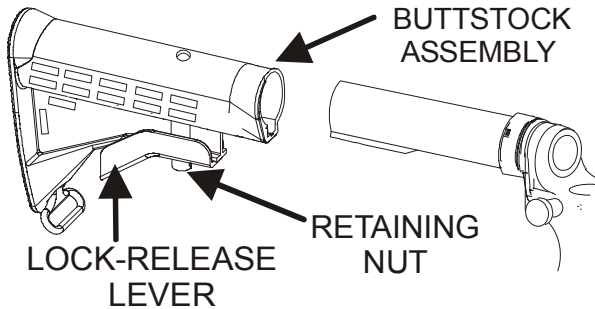

NOTE

No further disassembly allowed.

Removal of Rail Adapter Covers

1. Rail covers quickly detach and attach to adapter rails. Rail covers have a retaining clip at the end of each handguard section that automatically engages a slot at either end of all the rail sections.

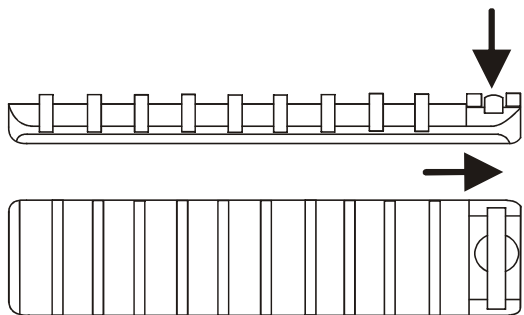

2. Remove cover by pushing in on the middle of retaining clip and sliding cover off the rail end closest to the clip.

Magazine Disassembly

1. Release base catch with the end of a cleaning rod.

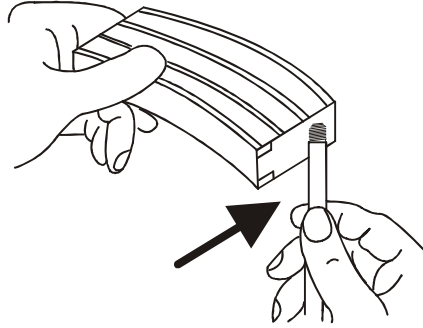

2. Remove base.

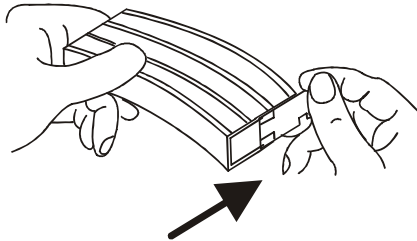

3. Jiggle spring and follower to remove.

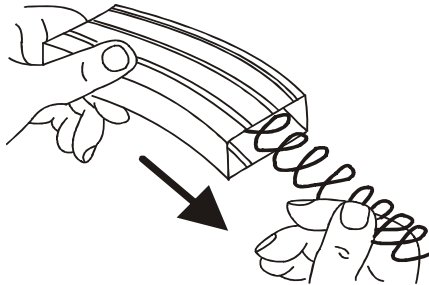

4. Inspect feeder lips for damage. Replace magazine if damaged or bent.

END OF WORK PACKAGE

OPERATOR
CLEANING INSTRUCTIONS

INITIAL SETUP**Tools:**

Cleaning Rods
and Handle
Bore Brush
Chamber Brush
Swab Hold
Small Arms
Cleaning Brush

Materials:

Cleaning Swabs
Pipe Cleaners
CLP Lubricant
RBC-Rifle Bore
Cleaner
Wiping Rags

WARNING

ALWAYS clear the weapon before cleaning.

CAUTION

Do not mix parts the parts of one weapon with other weapons. Parts are not interchangeable.

GENERAL**NOTE**

DO NOT mix lubricants on the same weapon.

The term CLP or the word lubricant in this TM is to be interpreted to mean that CLP, LSA, LAW can be utilized as applicable. The weapon must be thoroughly cleaned during change from one lubricant to another using dry cleaning solvent (SD). Do not mix lubricants on the same weapon.

Supplies

1. Always shake CLP before using.
2. Cleaning materials (swabs, pipe cleaners, and CLP) are expendable items available from supply.

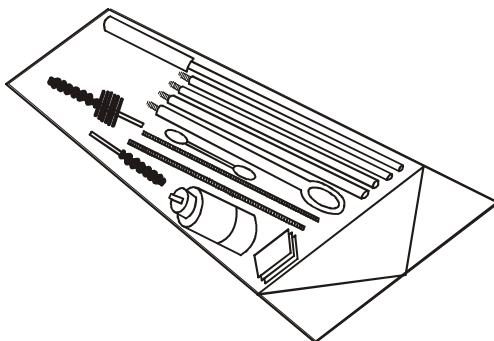

3. Cleaning gear can be stored in buttstock of M16 Rifles.

Bore

1. Disassemble weapon.
2. The bore of your weapon has lands and grooves called rifling. Rifling makes the bullet spin very fast as it moves down the bore and down range. Because it twists so quickly, it is difficult to push a new, stiff bore brush through the bore. You will find it easier to pull your bore brush through the bore. Also, because the brush will clean better if the bristles follow the grooves (called tracking), you want the bore brush to be allowed to turn as you pull it through.
3. Attach three cleaning rod sections together.
4. Swab out the bore with a patch moistened with CLP or rifle bore cleaner (RBC).
5. Attach the bore brush. When using bore brush, don't reverse direction while in bore.

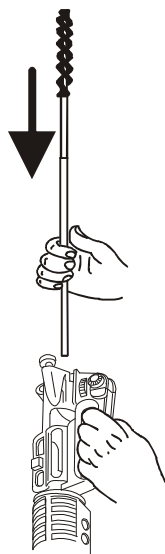

6. Point muzzle down. Hold the upper receiver in one hand while inserting the end of the rod without the brush into the chamber. Let the rod fall straight through the bore. About 2 to 3 inches will be sticking out of the muzzle at this point.

7. Attach the handle section of the cleaning rod to the end of the rod sticking out of the muzzle.

8. Pull the brush through the bore and out the muzzle.

9. After one pull, take off the handle section and repeat the process.

10. Send a patch through the bore once in a while to help clean out the dirt that the brush is getting loose. Replace the bore brush with the rod tip (patch holder and a wet patch). Drop it through. You won't need to attach the handle to pull only a patch through.

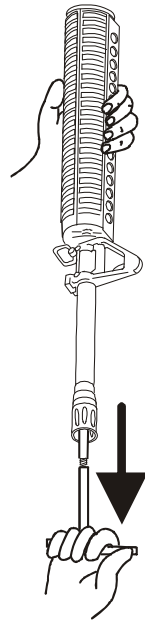

UPPER RECEIVER

1. Connect chamber brush to cleaning rod handle. Dip the chamber brush in CLP and insert in chamber and locking lugs. Push and twist to clean.

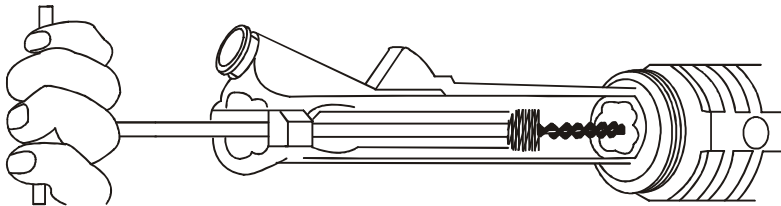

- Use a worn out bore brush to clean outside of gas tube.

NOTE

Gas tubes will discolor from heat. **DO NOT** attempt to remove discoloration.

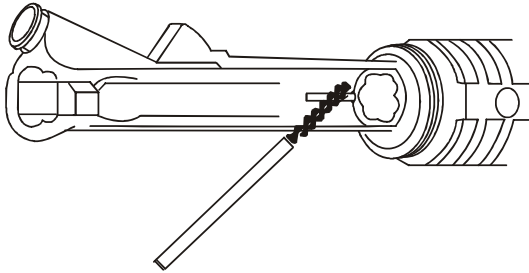

- Wipe down and clean entire upper receiver.

Bolt Carrier Assembly

- Clean carbon and oil from firing pin (1).

- Clean bolt carrier key (2) with worn brush.

- Clean firing pin recess (3) with pipe cleaner.

- Clean firing pin hole (4) with pipe cleaner.

- Clean behind bolt rings and lip of extractor (5).

- Clean carbon deposits and dirt from locking lugs (6).

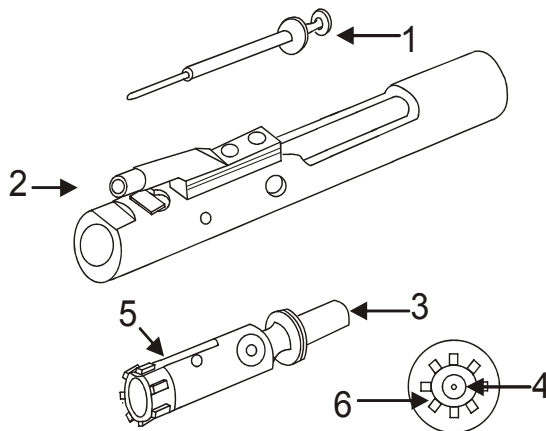

Lower Receiver and Buttstock Assembly

CAUTION

DO NOT use wire brush or any other type of abrasive material to clean aluminum surfaces.

1. Wipe dirt from trigger with a swab.
2. Use a swab dampened with CLP to clean powder fouling, corrosion, and dirt from outside parts of lower receiver and extension assembly.
3. Use pipe cleaner to clean buttstock drain hole.

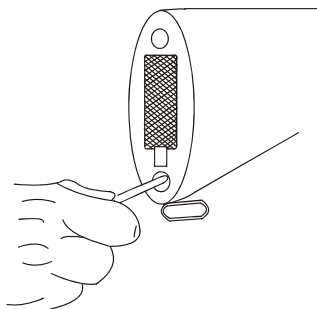

4. Clean buffer assembly, spring, and inside with swab dampened with CLP. Wipe dry.

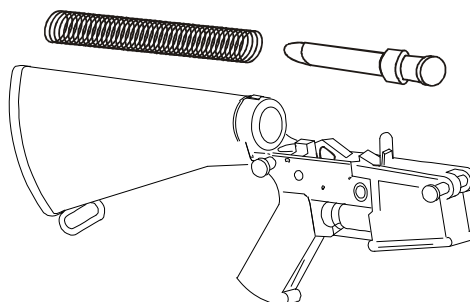

Ejector

1. Place a few drops of CLP on the ejector.

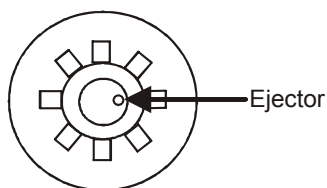

WARNING

DO NOT use a live round to perform this process.

2. Press the ejector in using a spent round casing or dummy round. Hook casing under extractor and rock back and forth against ejector. Repeat this process a few times adding lubricant until the action of the ejector is smooth and strong.

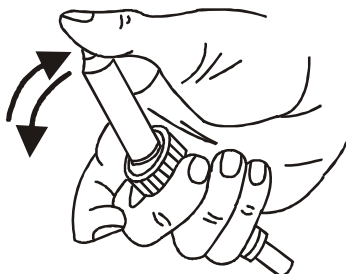

3. Dry off excess CLP when process is completed.

Cleaning Adapter Rails and Covers**NOTE**

DO NOT apply CLP to the plastic surfaces of the rail covers.

1. Remove rail covers from adapter rails.
2. Use a general-purpose brush from the standard cleaning kit to clean the adapter rails and rail covers.
3. Lightly lubricate the upper and lower rail assemblies and retaining clips in the rail covers.
4. Remove the lower adapter rail when debris is present and thoroughly clean the thermal liner to maintain heat reflective surface. **DO NOT** remove the heat reflective surface from lower adapter rail.
5. When exposed to salt water or corrosive materials, rinse the upper and lower rail assemblies in fresh water as soon as tactically possible and thoroughly clean, inspect, and lubricate as required.

END OF WORK PACKAGE

OPERATOR

INSPECTION INSTRUCTIONS

INITIAL SETUP

References
WP0006

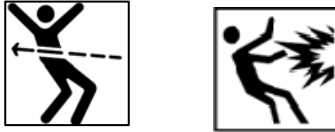
Upper Receiver and Barrel Assembly**WARNING**

DO NOT interchange bolts between weapons.

1. Inspect handguards or rails (1) for cracks, broken tabs, proper installation, and loose heat shields.
2. Inspect front sight post (2) for straightness and check depression of the front detent.
3. Inspect compensator (3) for looseness.
4. Inspect barrel (4) for straightness, cracks, burrs or looseness.
5. Inspect charging handle (5) for cracks, bends, or breaks.
6. Inspect rear sight assembly (6) for properly working windage and elevation adjustments. Ensure the short and long range sight spring holds the selected sight in place.
7. Inspect gas tube (7) for bends or retention to barrel.

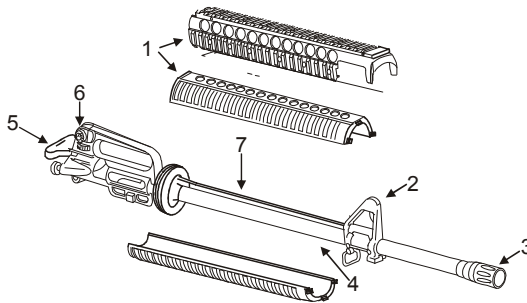

Bolt and Bolt Carrier Assembly

1. Inspect bolt cam pin (1) for cracking or chipping.
2. Inspect firing pin (2) for bends, cracks, and sharp or blunted tip.
3. Inspect for missing or broken gas rings (3).
4. Inspect bolt cam pin area (4) for cracking or chipping.
5. Inspect locking lugs (5) for cracking or chipping. Inspect bolt face (6) for excessive pitting.
6. Inspect extractor assembly (7) for missing extractor spring assembly with insert and for chipped or broken edges on the lip which engages the cartridge rim.
7. Inspect firing pin retaining pin (8) to determine if bent or badly worn.
8. Inspect bolt carrier for loose bolt carrier key (9).
9. Inspect for cracking or chipping in cam pin hole area (10).

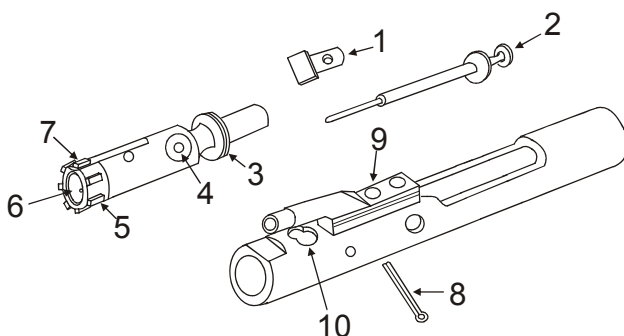

Lower Receiver and Buttstock Assembly

1. Inspect buffer (1) for cracks or damage.
2. Inspect buffer spring (2) for kinks.
3. Inspect buttstock (3) for broken buttplate or cracks.
4. Inspect for bent or broken selector lever (4).
5. Inspect rifle grips (5) for cracks or damage.
6. Inspect for broken or bent trigger (6).
7. Visually inspect the inside parts of the lower receiver (7) for broken or missing parts.

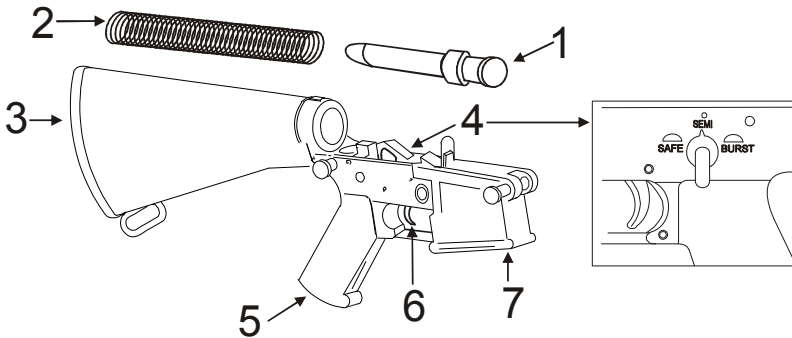
**END OF WORK PACKAGE**

OPERATOR

LUBRICATION INSTRUCTIONS

INITIAL SETUP

Tools:

Cleaning Rods
and Handle
Chamber Brush
Swab Holder

Materials:

CLP Lubricant
LSA Lubricant
LAW Lubricant Oil
Arctic Weather
Dry Cleaning Solvent
Cleaning Swabs
Wiping Rags

CLP-Cleaner, Lubricant, and Preservative

1. Always shake bottle well before use.
2. Place a few drops on rag or swab.
3. Clean weapon with CLP dampened rag or swabs until clean.
4. Apply a fresh, light coat of CLP with new rag or swab.

NOTE

DO NOT “dry clean” your weapon. **DO NOT** use hot water or other solvents or you will wash away the Teflon lubricant that has been building up as a result of you using CLP. If CLP is not used, RBC may be used to remove carbon within the bore. Dry cleaning solvent may be used to completely remove lubricants. For example, when moving to extreme cold weather operations, to remove traces of CLP before applying LAW.

Lubricant Guide

Under all but the coldest Arctic conditions, CLP or LSA are the lubricants to use on your weapon. Remember to remove excessive lubricant from the bore and chamber before firing.

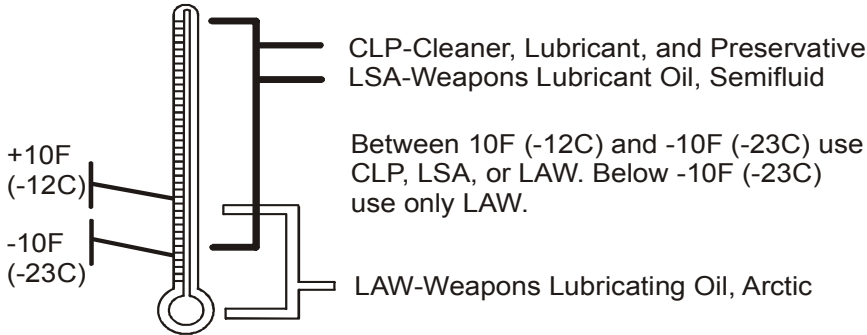

Lightly Lubricated—A barely visible film of lubricant.

Generously Lubricated—Lubricant is thick enough to spread with finger.

Upper Receiver

Lightly lubricate inside of upper receiver, bore, chamber, front sight, outer surfaces of barrel, and under the handguards.

Lubricate front sight detent. Depress front sight detent, add a drop of lubricant, and work the detent up and down to work lubricant into the spring.

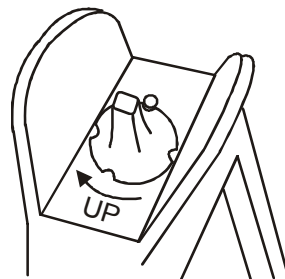

Upper Receiver (cont.)

Lubricate locking lugs. Add a few drops of lubricant to the chamber brush and insert into the chamber and locking lugs.

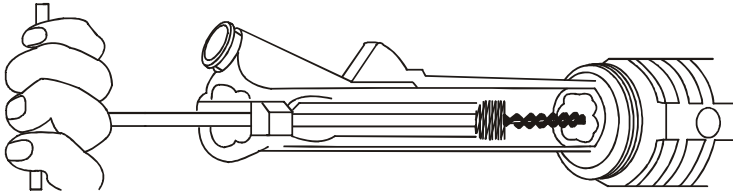

Lubricate inside of barrel. Add a few drops of lubricant to a swab patch on cleaning rod. Send the cleaning rod through the bore from chamber to muzzle.

CAUTION
DO NOT change direction in bore.

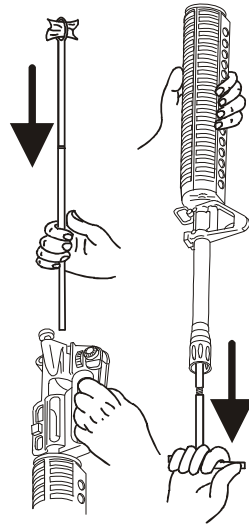

Carrying Handle and Upper Rail for M4, M4A1, M16A3, and M16A4

1. Apply a drop or two of lubricant to both threaded studs.
2. Lightly lubricate the clamping bar and both round nuts.
3. Lightly lubricate the mating surfaces of the carrying handle assembly and upper rail.

NOTE

DO NOT switch carrying handles between weapons. Switching carrying handles may change your weapon's zero.

Bolt Carrier Assembly

1. Lightly lubricate firing pin and firing pin recess in bolt.
2. Place one drop of lubricant in carrier key.

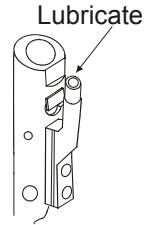

3. Generously lubricate the outside of the parts: Cam pin area, bolt rings, outside of bolt body.

4. Lightly lubricate extractor and pin.

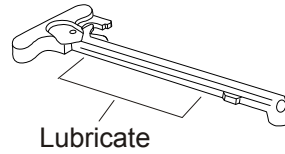

5. Lightly lubricate charging handle and inner/outer surfaces of bolt carrier. Generously lubricate slide and cam pin area of bolt carrier.

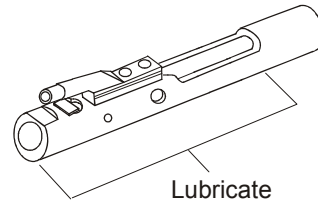

Lower Receiver Assembly

1. Lightly lubricate inside the buffer tube (1).
2. Generously lubricate takedown (2) and pivot pins (3) and detents. Lightly lubricate all moving parts and pins inside lower receiver (4).

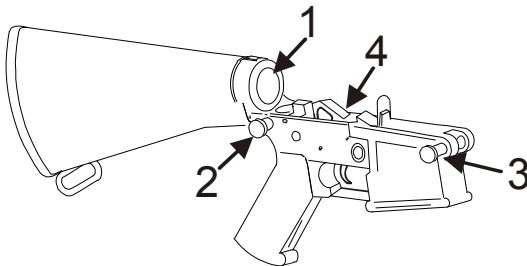

Adjustable Rear Sight

NOTE

Make a note of how far you move the sight so it can be returned to the original position after completion of this task.

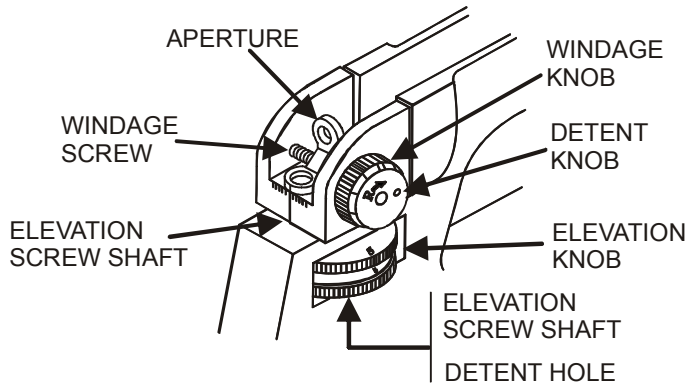

1. Use one drop of lubricant and rotate each part to ensure lubricant is spread evenly.
2. Elevation Screw Shaft. Lubricate from the inside of the upper receiver as follows:
 - a. M16A2 and M16A3: Turn upper receiver upside down and remove charging handle. M4, M4A1, and M16A4: Remove carrying handle.
 - b. Put two or three drops around the bottom edge of the elevation screw shaft and in elevation detent spring hole.
 - c. Rotate the elevation dial as far as possible a few times while holding receiver upside down.

Back Up Iron Sight (BUIS)

1. Lubricate entire BUIS with light coat of lubricant.
2. Rotate sight cam to 600-meter mark. Apply 2 or 3 drops of lubricant to index spring and ball bearing through hole in bottom of sight cam.
3. Apply 2 or 3 drops of lubricant to plunger and compression spring beneath flip-up aperture sight.

4. Apply 2 or 3 drops of lubricant to index spring and ball bearing through hole in the side of windage knob.
5. Apply light coat of lubricant to threads of the windage screw. Turn screw side-to-side before returning to original zeroing mark.

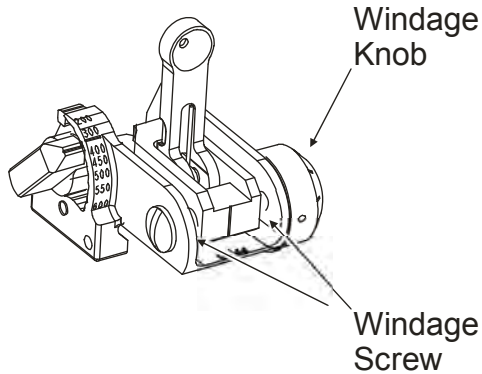

After Lubricating Rear Sight

1. Reset your correct zero windage and your battlesight zero.
2. Notice the rear sight comes down when the "3" is aligned with the mark on the left side of the receiver.
3. There will be a "click" when the "3" lines up with the mark.
4. Carry weapon with the "3" aligned with the mark.
5. Keep the sight on 300 meters to keep dirt and water out of sight mechanism and protect the sight from damage.

END OF WORK PACKAGE

OPERATOR
REASSEMBLY INSTRUCTIONS

INITIAL SETUP**R eferences**

WP0014

TM 9-1010-221-10

TM 9-1010-221-23&P

SW 370-AE-MMI-010

NOTE

Be sure not to lose extractor spring and rubber insert.

1. Place large end of extractor spring in the extractor and seat it by pushing and turning clockwise.

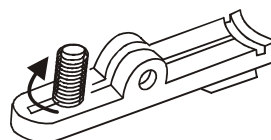

2. Insert extractor assembly into bolt.

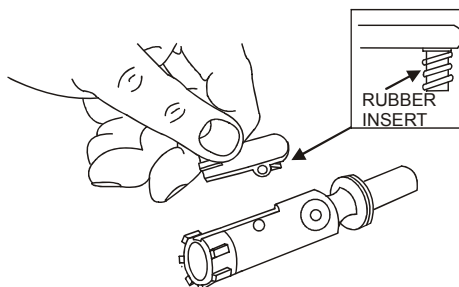

3. Install extractor pin.

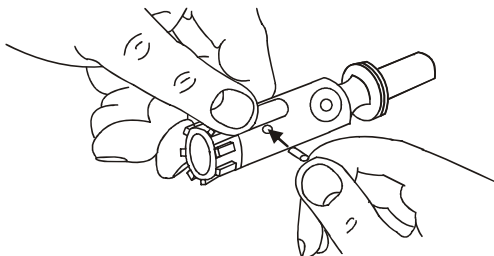

4. Slide bolt into carrier.

CAUTION
DO NOT switch bolts
 between weapons.

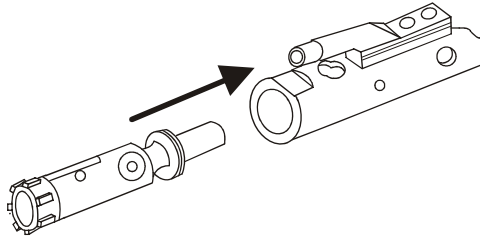

5. Insert bolt cam pin.
 Turn cam pin a $\frac{1}{4}$
 turn after
 reassembly.

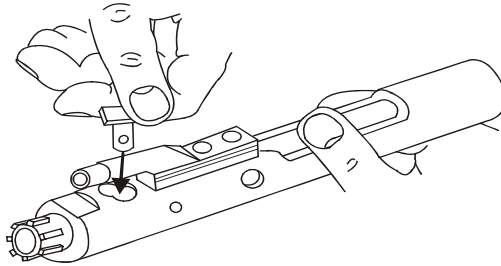

WARNING



Ensure cam pin is installed in the bolt carrier assembly. The
 weapon will explode when fired if cam pin is not installed.

6. Drop firing pin into carrier and
 seat the firing pin.

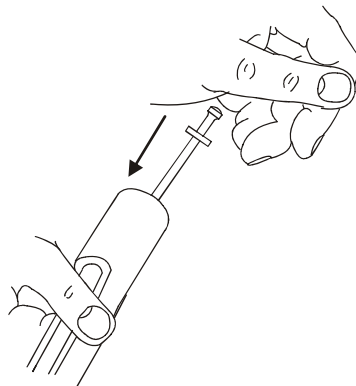

7. Pull bolt out.

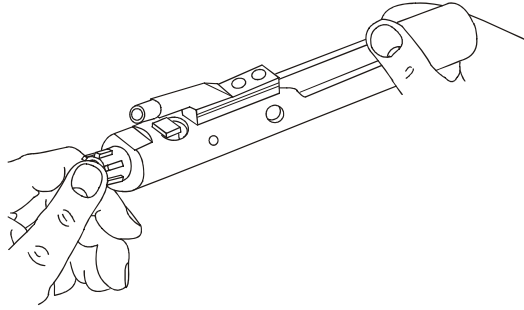

8. Insert firing pin retaining pin.

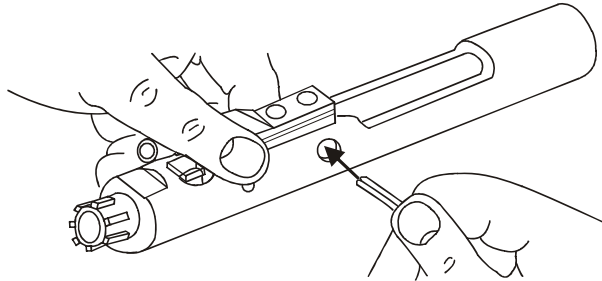

NOTE

Firing pin should not fall out when bolt carrier assembly is turned upside down.

9. Insert charging handle part way.

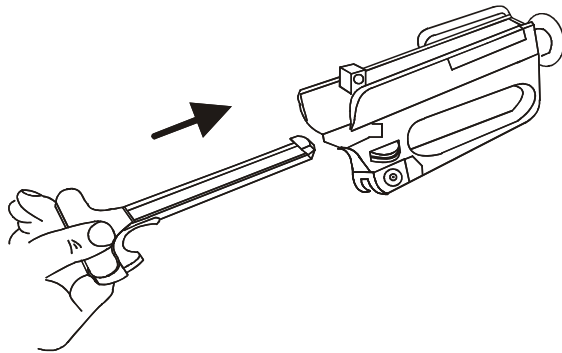

10. Slide bolt carrier assembly into charging handle groove.

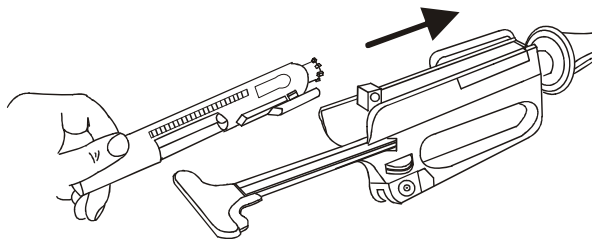

11. Push charging handle and bolt carrier assembly together into upper receiver until fully seated.

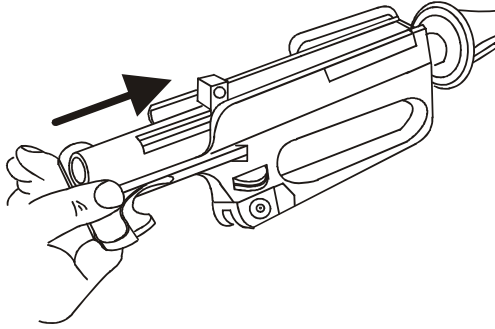

CAUTION

If round nuts and clamping bar is removed, reinstall clamping bar on threaded studs. Clamping bar should not extend beyond the front of the carrying handle. Reinstall round nuts on the threaded studs.

NOTE

DO NOT reflare end of threaded studs if nuts have been removed.

12. **M4/M4A1/M16A4 only.** The carrying handle assembly should be reinstalled on the front notch of the upper receiver rail. Slide the clamping bar against the receiver with the lower edge underneath the slotted section. Hand tighten round nuts.

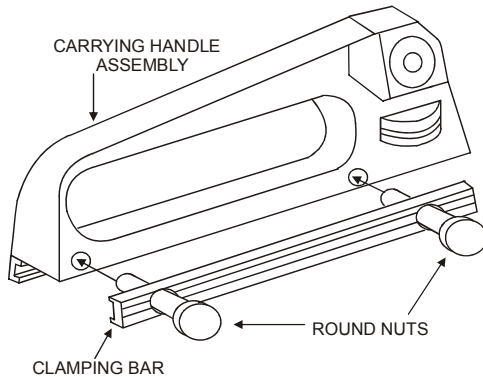

13. Reassemble buttstock:

a. **M4/M4A1 only.** Grasp the lock release lever in the area of the retaining nut and pull to reinstall the buttstock assembly onto the lower receiver extension.

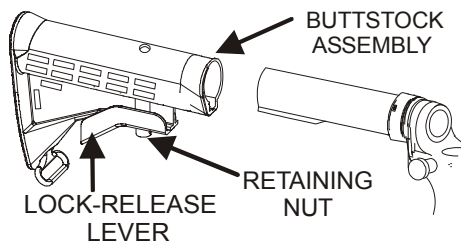

b. **M16A1/A2/A3/A4 only.** Insert buffer and buffer spring into buttstock.

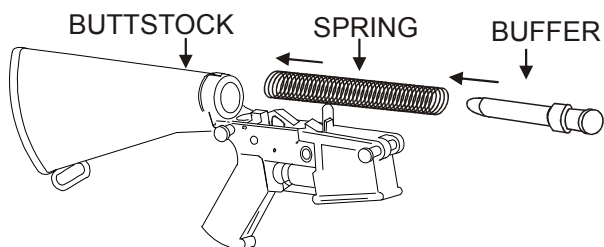

14. Join upper and lower receivers.

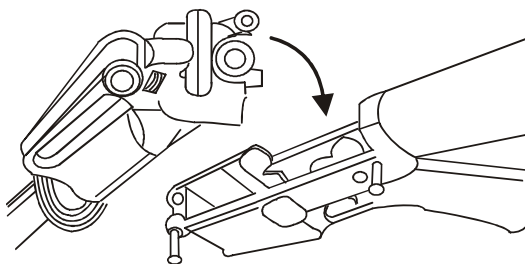

15. Engage receiver pivot pin.

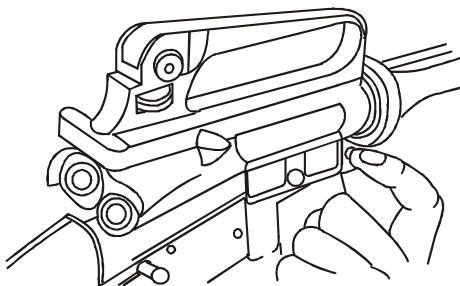

CAUTION

Selector lever must be on **SAFE** or **SEMI** before closing upper receiver.

16. Close upper and lower receiver assembly. Push in takedown pin.

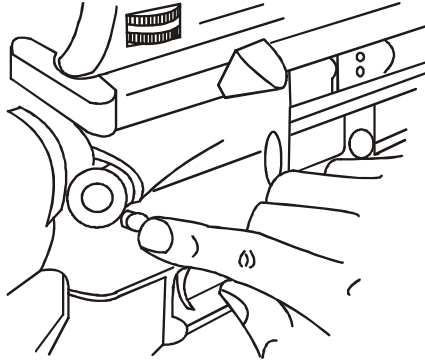

17. Assemble handguards (Step 17a) or lower adapter rail (Step 17b).

CAUTION

DO NOT use a screwdriver or any other tool when assembling handguards/lower rail as it may cause damage to the handguards/lower rail and/or slip ring.

NOTE

Installation of the rail has no effect on the attachment or operation of the Multiple Integrated Laser Engagement System (MILES), the M7 and M9 bayonets, the M15A2 and M23 blank firing adapters, the top carry sling adapter, and standard sling.

Remove the lower adapter rail to mount the M203 Grenade Launcher in its standard location using the M203 Quick Attach/Detach (QD) Mount, TM 9-1010-221-10.

17a. Place the weapon on the buttstock and press down on the slip ring with both hands. Have another person place the top and bottom handguards on the weapon. (Buddy System)

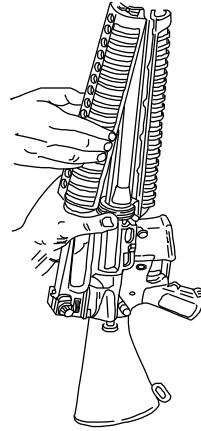

17b. Insert the front flange of the lower rail under the front handguard cap. Pull back on the handguard slip ring. Pivot rear flange of adapter rail over the edge of the handguard slip ring and release the slip ring. Ensure the handguard slip ring engages completely around the flange.

NOTE

The front of the lower adapter rail is identified by an arrow on the heat shield inside the rail.

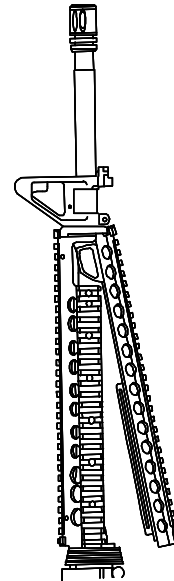

18. Install sling.

Installation of Adapter Rail Covers

1. Install the right, left, and bottom rail covers from the muzzle end of the adapter rails. Ensure all rail covers have the retaining clip secured in the slot on the adapter rail.
2. Install top adapter rail covers from the receiver end of the rail assembly.

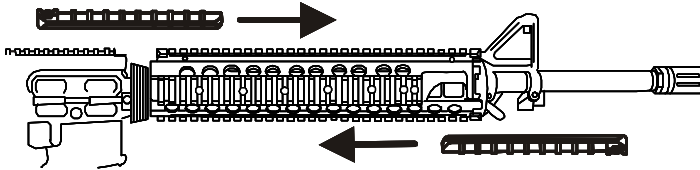

3. Retaining clips on the rail covers will lock into the slots at either end of the adapter rail. Rail covers will not lock into any other part of the adapter rail.

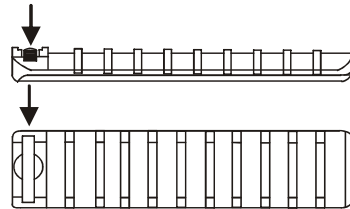

Magazine Reassembly

1. Clean and lubricate magazine. Wipe dirt from tube, spring, and follower.

NOTE

If the spring detaches from the follower, turn in for repair. **DO NOT** try to fix yourself.

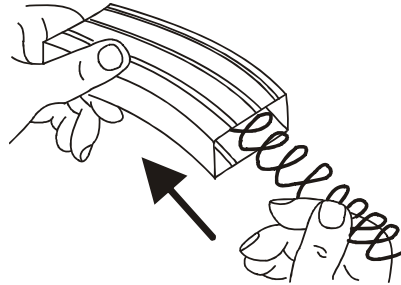

2. Insert follower and jiggle spring to install.

3. Slide the base under all four tabs until base catches.

NOTE

Make sure printing on base is on the outside, if present.

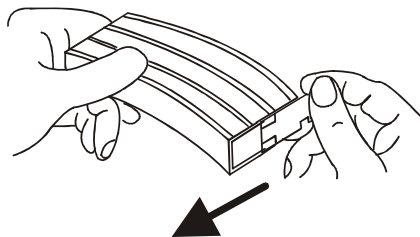

END OF WORK PACKAGE

CHAPTER 5
AMMUNITION

OPERATOR
AMMUNITION

5.56MM**WARNING****DO NOT FIRE:**

Corroded ammunition.
Dented cartridges.
Cartridges with loose bullets.
Cartridges exposed to extreme heat (135° Fahrenheit / 57° Celsius) until cartridges have cooled.
Cartridges with the bullet pushed in (short rounds).
Turn in all bad rounds to range Non-Commissioned Officer (NCO).

Use only authorized ammunition.



M200
Blank

M193
Ball

M855
Ball

M856
Tracer

M995
Armor
Piercing
(AP)



**Dummy
M199**

**CCMCK
M1042
Blue**

**CCMCK
M1042
Red**

**CCMCK
M1042
Yellow**

**SRTA
M862**

**AA40
(Air Force
Only-
Fragible)**

Keep ammunition dry and clean.

END OF WORK PACKAGE

CHAPTER 6
SUPPORTING INFORMATION

OPERATOR**REFERENCES**

Department of the Army Pamphlets and Forms

DA PAM 750-8 The Army Maintenance Management System (TAMMS)
DA Form 2028..... Recommended Changes to Publications and Blank Forms
NAVSEA 4160/1.....NAVSEA/SPAWAR Technical Manual Deficiency/Evaluation Report (TMDER)
SF 364 Report of Discrepancy (ROD)
SF368 Product Quality Deficiency Report

Field Manuals

FM 3-22.9..... M16A1 Rifle and Rifle Marksmanship
FM 3-3..... Nuclear, Biological and Chemical Contamination Avoidance
FM 3-4..... Nuclear, Biological and Chemical Protection
FM 3-5..... Nuclear, Biological and Chemical Decontamination
FM 3-100..... Nuclear, Biological and Chemical Defense, Chemical Warfare, Smoke, and Flame Operations
FM 21-11..... First Aid for Soldiers

Technical Manuals

SW 370-AE-MMI-010 Unit and Direct Support
Maintenance Manual for M203 Grenade Launcher

TM 3-4230-216-10 Operator's Manual for
Decontamination Kit, Skin: M258A1 and Training Aid, Skin
Decontaminating: M58A1

TM 9-1005-319-23&P Field Maintenance Manual for,
M16A2/M16A3/M16A4 Rifle and M4/M4A1 Carbine

TM 9-1010-221-10 Operator's Manual for M203
Grenade Launcher

TM 9-1010-221-23&P Unit and Direct Support
Maintenance Manual for M203 Grenade Launcher

TM 4700-15/1 Record Reporting Procedures

Related Publications

DOD 4160.21-M-1 Defense Demilitarization Manual

SI-1300-15/2B Procedure for Requesting
Disposition for Class V (W) Materiel

END OF WORK PACKAGE

OPERATOR**COMPONENTS OF END ITEM and BII Lists**

Scope

These work packages list Components of End Item (COEI) and Basic Issue Items (BII) for the M16 series rifles and M4 series carbines to help inventory items required for safe and efficient operation of the equipment.

General

The COEI and BII Lists are divided into the following lists:

COEI: This list is for informational purposes only and does not authorize the requisitioning of replacement items. These items are part of the M16 series rifles and the M4 series carbines. These items **MUST** be with the end item whenever it is issued or transferred to property accounts. Items of COEI is only removed and separately packaged for transportation or shipment when necessary.

BII: These items are required to operate or to do emergency repairs on the M16 series rifles and M4 series carbines. BII must be with the M16 series rifles and M4 series carbines whenever it is issued or transferred to property accounts. This list authorizes the requisitioning of replacement parts based on authorization of the end item by the TOE/MTOE. Illustrations are furnished to help find and identify the items.

Explanation of Columns in the COEI List and BII List

Column (1) – Illus Number: Gives number of item illustrated.

Column (2) – National Stock Number (NSN): Identifies the stock number of the item to be used for requisitioning.

Column (3) – Description, Commercial and Government Entity Code (CAGEC), and Part Number (P/N): Identifies the federal name (in all capital letters) followed by a minimum description when needed. The stowage location of COEI and BII is also included in this column. The CAGEC is listed in parentheses followed by the part number.

Column (4) – Used On Code: This code is used to identify items that are not the same for different models of the same equipment.

Column (5) – Unit of Measure (U/M): Indicates the physical measurement or count of the item as issued per the NSN shown in Column (2).

Column (6) – Qty Rqr: Indicates the quantity required.

Table 1. COMPONENTS OF END ITEM LIST

(1) ILLUS NO.	(2) NATIONAL STOCK NUMBER	(3) DESCRIPTION, CAGEC, AND PART NUMBER	(4) UOC	(5) U/M	(6) QTY RQR
1	1005-00-561-7200	MAGAZINE, CARTRIDGE: 30 Round (19204) 8448670		EA	1
2	1005-01-216-4510	SLING, SMALL ARMS (19204) 12624561		EA	1
3	1005-01-368-9852	SLING, SMALL ARMS, CARBINE (19200) 12011996		EA	1

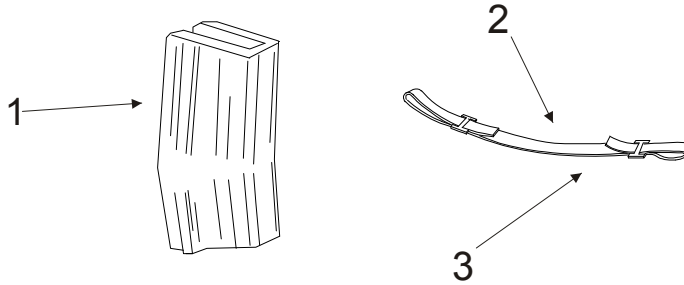
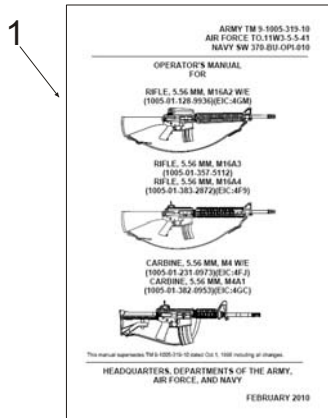

Table 2. BASIC ISSUE ITEM LIST

(1) ILLUS NO.	(2) NATIONAL STOCK NUMBER	(3) DESCRIPTION, CAGEC, AND PART NUMBER	(4) UOC	(5) U/M	(6) QTY RQR
1		TM 9-1005-319-10		EA	1



END OF WORK PACKAGE

0020 00-3/4 blank

OPERATOR
ADDITIONAL AUTHORIZED LISTS (AAL)

Scope

This work package lists additional items authorized to support the M16 series rifles and M4 series carbines.

General

This list identifies items that do not have to accompany the M16 series rifles and M4 series carbines. These items do not have to be turned in with the weapon. These items are all authorized by CTA, MTOE, TDA, or JTA.

Explanation of Columns in AAL

Column (1) – National Stock Number (NSN): Identifies the stock number of the item to be used for requisitioning.

Column (2) – Description, Commercial and Government Entity Code (CAGEC), and Part Number (P/N): Identifies the federal name (in all capital letters) followed by a minimum description when needed. The CAGEC is listed in parentheses followed by the part number.

Column (3) – Used On Code: This code is used to identify items that are not the same for different models of the same equipment. Uncoded items are applicable to all models.

<u>Code</u>	<u>Used On</u>
AR8	M16A2 Rifle
AW4	M16A3 Rifle
AZ1	M16A4 Rifle
AS1	M4 Carbine
AY6	M4A1 Carbine

Column (4) – Unit of Issue (U/I): Indicates the physical measurement or count of the item as issued per the NSN shown in Column (1).

Column (5) – Qty Recm: Indicates quantity recommended.

TABLE 1. ADDITIONAL AUTHORIZED ITEMS LIST

(1) NATIONAL STOCK NUMBER	(2) DESCRIPTION, CAGEC, AND PART NUMBER	(3) UOC	(4) U/I	(5) QTY RECM
1005-01-541-2476	ADAPTER RAIL, WEAPON MOUNTED: forward rail bracket used on weapons without a rail system (19200) PRF13018852	AR8	EA	1
1005-01-541-1772	BIPOD, RIFLE: grip bipod used with rail system or in conjunction with forward rail bracket (1005-01-541-2476) (19200) PRF13018853		EA	1
1005-01-558-6664	BIPOD, RIFLE: squad designated marksman bipod used with rail system or in conjunction with forward rail bracket (1005-01-541-2476) (19200) 13018854		EA	1
1005-00-118-6192	BLANK FIRING ATTACHMENT M15A2: (For Training Only) (Rifle Only) (Red) (19204) 12002900	AR8 AW4 AZ1	EA	1
1005-01-361-8208	BLANK FIRING ATTACHMENT M23: (For Training Only) (Carbine Only) (Yellow) (19200) 12597837	AS1 AY6	EA	1
5340-01-230-3181	BRACKET, MOUNTING: required to restrain M4/A1 in M12 arms rack (19200) 12556036	AS1 AY6	EA	1
5340-01-485-1916	BRACKET, MOUNTING: flashlight mount used with rail system (19200) 12997559	AS1 AY6 AZ1 AW4	EA	1
1005-01-544-9825	BUTTSTOCK, SUBASSEMBLY: enhanced sliding buttstock (19200) 13020680	AS1 AY6	EA	1
5340-00-880-7666	CAP, PROTECTIVE, DUST (19204) 8445067		EA	1
1005-00-403-5804	CASE, SMALL ARMS: for rifles with buttstock storage (19204) 8448751		EA	1

TABLE 1. ADDITIONAL AUTHORIZED ITEMS LIST (cont)

(1) NATIONAL STOCK NUMBER	(2) DESCRIPTION, CAGEC, AND PART NUMBER	(3) UOC	(4) U/I	(5) QTY RECM
8465-00-781-9564	CASE, MAINTENANCE EQUIPMENT: for weapons without buttstock storage (81349) MIL-C-43737		EA	1
1005-01-465-0401	HANDLE, GUN CARRYING: needed to install quadrant sight when M203A2 is applied to weapon (19200) 12951011	AW4 AZ1 AS1 AY6	EA	1
1005-01-541-2477	HOLDER, MULTIPLE MAGAZINE: allows for two magazines to be attached for more efficient loading (19200) 13018851		EA	1
1005-01-478-0848	KIT, CLOSE QUARTERS COMBAT SLING ADAPTER (19200) 12956271		EA	1
1005-01-558-7980	KIT, CLEANING, IMPROVED WEAPON (19200) PRF13018855		EA	1
5340-00-233-9031	LOCKING PLATE: for riot control use, prevents selector from automatic fire (refer to unit maintenance for installation and instructions on use) (19204) 844676		EA	1
1005-01-561-7200	MAGAZINE, CARTRIDGE: 30 round (19200) 13021312		EA	6
1005-01-394-7677	PROTECTOR, RAIL: protects M4/A1 rail from being damaged when placed in arms rack (19200) 12972676	AS1 AY6	EA	1
1005-01-541-1771	SLING, SMALL ARMS: tactical quick release sling (19200) PRF130158850		EA	1
1005-01-569-6938	STOCK, GUN, SHOULDER: collapsible buttstock for M16A2/A4 (M4/A1 buffer should NOT be used with this buttstock) (19200) 13023910	AR8 AZ1 AW4	EA	1
1005-00-406-1570	TOP SLING ADAPTER KIT (19204) 8448471		EA	1

END OF WORK PACKAGE**0021 00-3/4 blank**

OPERATOR

**EXPENDABLE/DURABLE SUPPLIES AND
MATERIALS LISTS**

Scope

This work package lists expendable and durable items needed to operate and maintain the M16 series rifles and M4 carbines. This list is for information only and does not authorize the requisitioning of the listed items. These items are authorized by CTA 50-970, Expendable/Durable Items (except Medical, Class V Repair Parts, and Heraldic Items), CTA 50-909, Field and Garrison Furnishings and Equipment or CTA 8-100, Army Medical Department Expendable/Durable Items.

Explanation of Columns in the Expendable/Durable Items List

Column (1) – Item Number: This number is assigned to the entry in the list and is referenced in the narrative instructions to identify the item (e. g., use wiping rag)

Column (2) – Level: This column identifies the lowest level of maintenance required to work on the listed item.
(C = Crew, O = AMC, F = Maintainer or ASB, H = Below Depot or TASMG, D = Depot).

Column (3) – National Stock Number (NSN): The number assigned to the item in the list used for requisitioning the item.

Column (4) – Item Name, Description, Commercial and Government Entity Code (CAGEC), and Part Number (P/N): Identifies the federal name (in all capital letters) followed by a minimum description when needed. The CAGEC is listed in parentheses followed by the part number.

Column (5) – Unit of Issue (U/I): Indicates the physical measurement or count of the item as issued per the NSN shown in Column (3).

Table 1. EXPENDABLE AND DURABLE ITEMS LIST

(1) ITEM NUMBER	(2) LEVEL	(3) NATIONAL STOCK NUMBER	(4) DESCRIPTION, CAGEC, AND PART NUMBER	(5) U/I
1	C	1005-00-242-5687	BOTTLE ASSEMBLY, CYLINDRICAL (19204) 8448444	AY
2	C	8020-00-244-0153	BRUSH, ARTISTS (80244) 8020-00-244-0153	EA
3	C	1005-00-903-1296	BRUSH, CLEANING, SMALL ARMS: bore (19204)11686340	EA
4	C	1005-00-999-1435	BRUSH, CLEANING, SMALL ARMS: chamber (19204) 8432358	EA
5	C	1005-00-494-6602	BRUSH, CLEANING, SMALL ARMS: toothbrush (19204) 8448462	EA
6	C	7920-00-205-2401	BRUSH, CLEANING, TOOLS AND PARTS (81349) MILS43871	EA
7	C	9150-01-102-1473 9150-01-079-6124 9150-01-054-6453 9150-01-053-6688	CLEANER, LUBRICANT AND PRESERVATIVE (CLP): (81349) MIL-L-63460 1/2 oz bottle 4 oz bottle 1 pt can 1 gal	BT BT PT GL
8	C	9920-00-292-9946	CLEANER, TOBACCO PIPE: cotton fibers, wire core (1344 per box) (64067) 9920-00-292-9946	BX
9	C	6850-00-224-6656 6850-00-224-6657 6850-00-224-6663	CLEANING COMPOUND, RIFLE BORE (RBC): (81349) MIL-PRF-372 2oz bottle 8 oz can 1 gal can	BT CN GL
10	C	5350-00-221-0872	CLOTH, ABRASIVE (50 sheets) (81348) P-C-458	PG
11	C	1005-00-809-2190	COVER, PROTECTIVE, RIFLE for M16 Series Rifles (25 per box) (19204) 8448213	BX
12	C	6850-01-474-2319 6850-01-474-2317 6850-01-474-2316	DRY CLEANING SOLVENT: (58536) MIL-PRF-680 TYPE II 1 gal 5 gal 55 gal.	GL GL DR

Table 1. EXPENDABLE AND DURABLE ITEMS LIST – Cont

13	C	8415-00-823-7458 8415-00-823-7459 8415-00-823-7460	GLOVES, RUBBER, INDUSTRIAL (81349) MIL-DTL-32066 Size 9 Size 10 Size 11	PR PR PR
14	C	1005-01-113-0321	HANDLE SECTION, CLEANING ROD, SMALL ARMS (19204) 8436776	EA
15	C	9150-00-292-9689	LUBRICATING OIL, ARCTIC WEAPONS (LAW) (1 quart can) (81349) MIL-L-14107	QT
16	C	9150-00-935-6597 9150-00-889-3522	LUBRICATING OIL, WEAPONS (LSA): Semifluid, (81349) MILL46000 2 oz bottle 4 oz bottle	BT BT
17	C	7920-00-205-1711	RAG, WIPING: 50 lb bale (58536) A-A-531	BE
18	C	1005-00-050-6357	ROD SECTION, CLEANING, SMALL ARMS (25 per box) (19204) 8436775 QTY Needed 3	BX
19	C	1005-00-937-2250	SWAB HOLDER SECTION, SMALL ARMS CLEANING (19204) 11686327	EA
20	C	1005-00-912-4248	SWAB, SMALL ARMS CLEANING: cotton (1000 per package) (19204) 11686408	PG
21	C	6920-01-482-0098	TARGET, 25 METER ZEROING (19200) 12988975	BX

END OF WORK PACKAGE

INDEX

<u>Subject</u>	<u>WP Sequence No. – Page No.</u>
A	
Additional Authorization List Item.....	WP 0021-2
Authorized Ammunition.....	WP 0018-1
B	
Basic Issue Items (BI).....	WP 0020-3
C	
Chambering Round from Bolt Closed Position.....	WP 0006-4
Cleaning Instruction.....	WP 0014-1
Clearing Weapon.....	WP 0006-1
Components of End Item (COEI).....	WP 0020-2
Corrosion Prevention and Control (CPC).....	WP 0001-2
D	
Definitions of Alerts Throughout this Manual.....	d
Department of the Army Pamphlets and Forms.....	WP 0019-1
Description and Use of Operator Controls and Indicators.....	WP 0005-1
Destruction of Army Materiel To Prevent Enemy Use.....	WP 0001-2
Disassembly Instruction.....	WP 0013-1
E	
Equipment Description and Data.....	WP 0002-1
Expendable and Durable Items List.....	WP 0022-2
Extreme Cold Climate – Arctic - Operation under Unusual Conditions..	WP 0007-1
F	
Field Manuals.....	WP 0019-1
Firing Modes.....	WP 0006-2
Function Check.....	WP 0008-1

INDEX - Continued

Subject WP Sequence No. – Page No.

H

Heavy Rain and Water Crossings – All Climates -
Operation under Unusual Conditions..... WP 0007-4
Hot, Dry Climate-Desert-
Operation under Unusual Conditions..... WP 0007-3
Hot, Wet Climate – Jungle –
 Operation under Unusual Conditions..... WP 0007-3
How To Use This Manual..... iv

I

Immediate Action..... WP 0006-7
Inspection Instructions..... WP 0015-1
Installation of Equipment..... WP 0010-1

L

List of Effective Pages/Work Packages..... A
Loading Magazine..... WP 0006-10
Loading Weapon and Chambering Round..... WP 0006-3
Location and Description of Major Components..... WP 0003-1
Lubrication Instructions..... WP 0016-1

M

Maintenance Forms, Records and Reports..... WP 0001-1

O

Operation Under Usual Conditions..... WP 0006-1
Operation Under Unusual Conditions..... WP 0007-1

P

Purpose of Equipment..... WP 0001-1
Preventive Maintenance Checks and Services..... WP 0012-3

INDEX - Continued

Subject WP Sequence No. – Page No.

R

Reassembly Instructions.....	WP 0017-1
References.....	WP 0019-1
Remedial Action.....	WP 0006-8
Reporting Equipment Improvement Recommendations (EIR).....	WP 0001-2

T

Table of Contents.....	iii
Technical Manuals.....	WP 0019-2
Theory of Operation.....	WP 0004-1
Three Round Burst Control.....	WP 0006-4
Troubleshooting Procedures.....	WP 0011-2

W

Warning Summary.....	a
----------------------	---

Z

Zeroing – 25 Meter.....	WP 0009-1
-------------------------	-----------

RECOMMENDED CHANGES TO PUBLICATIONS AND BLANK FORMS	Use Part II (reverse) for Repair Parts and Special Tools Lists (RPSTL) and Supply Catalogs/Supply Manuals (SC/SM).	DATE Date you filled out this form
For use of this form, see AR 25-30; the proponent agency is ODISC4.		

TO: (Forward to proponent of publication or form) (Include ZIP Code) U.S. Army TACOM Life Cycle Management Command ATTN: AMSTA-LCL-MPP/TECH PUBS 1 Rock Island Arsenal, Rock Island, IL 61299-7630	FROM: (Activity and location) (Include ZIP Code) Your mailing address
--	---

PART I - ALL PUBLICATIONS (EXCEPT RPSTL AND SC/SM) AND BLANK FORMS

PUBLICATION/FORM NUMBER TM 9-1005-319-10	DATE 30 June 2010	TITLE Operator's Manual for Rifle, 5.56 MM (NSN 1005-01-128-9936), (NSN 1005-01-357-5112) and (NSN 1005-01-383-2872), Carbine, 5.56 MM (NSN 1005-01-231-0973) and (NSN 1005-01-382-0953)
---	----------------------	---

ITEM NO.	PAGE NO.	PARA-GRAPH	LINE NO.*	FIGURE NO.	TABLE NO.	RECOMMENDED CHANGES AND REASON (Provide exact wording of recommended changes, if possible).
1	0017-3				1	Change Malfunction 6 Test or Inspection column to read "Check for bent or broken selector lever."

SAMPLE

*Reference to line numbers within the paragraph or subparagraph.

TYPED NAME, GRADE OR TITLE Your Name	TELEPHONE EXCHANGE/AUTOVON, PLUS EXTENSION	SIGNATURE Your Signature
---	--	-----------------------------

TO: <i>(Forward direct to addressee listed in publication)</i> U.S. Army TACOM Life Cycle Management Command ATTN: AMSTA-LCL-MPP / TECH PUBS, 1 Rock Island Arsenal Rock Island, IL 61299-7630	FROM: <i>(Activity and location) (Include ZIP Code)</i> Command Your address	DATE Date you filled out this form
---	---	--

PART II – REPAIR PARTS AND SPECIAL TOOL LISTS AND SUPPLY CATALOGS/SUPPLY MANUALS

PUBLICATION NUMBER TM 9-1005-319-10	DATE 31 May 2010	TITLE Operator's Manual for Rifle, 5.56 MM (NSN 1005-01-128-9936), (NSN 1005-01-357-5112) and (NSN 1005-01-383-2872), Carbine, 5.56 MM (NSN 1005-01-231-0973) and (NSN 1005-01-382-0953)
--	---------------------	---

PAGE NO.	COLM NO.	LINE NO.	NATIONAL STOCK NUMBER	REFERENCE NO.	FIGURE NO.	ITEM NO.	TOTAL NO. OF MAJOR ITEMS SUPPORTED	RECOMMENDED ACTION
<p>G5AD@</p>								

PART III – REMARKS

(Any general remarks or recommendations, or suggestions for improvement of publications and blank forms. Additional blank sheets may be used if more space is needed.)

TYPED NAME, GRADE OR TITLE Your Name	TELEPHONE EXCHANGE/AUTOVON, PLUS EXTENSION	SIGNATURE Your Signature
---	--	-----------------------------

RECOMMENDED CHANGES TO PUBLICATIONS AND BLANK FORMS						Use Part II (reverse) for Repair Parts and Special Tools Lists (RPSTL) and Supply Catalogs/Supply Manuals (SC/SM).	DATE
For use of this form, see AR 25-30; the proponent agency is ODISC4.							
TO: (Forward to proponent of publication or form) (Include ZIP Code) U.S. Army TACOM Life Cycle Management Command ATTN: AMSTA-LCL-MPP / TECH PUBS 1 Rock Island Arsenal Rock Island, IL 61299-7630						FROM: (Activity and location) (Include ZIP Code)	
PART I - ALL PUBLICATIONS (EXCEPT RPSTL AND SC/SM) AND BLANK FORMS							
PUBLICATION/FORM NUMBER TM 9-1005-319-10						DATE 30 June 2010	TITLE Operator's Manual for Rifle, 5.56 MM (NSN 1005-01-128-9936), (NSN 1005-01-357-5112) and (NSN 1005-01-383-2872), Carbine, 5.56 MM (NSN 1005-01-231-0973) and (NSN 1005-01-382-0953)
ITEM NO.	PAGE NO.	PARA-GRAPH	LINE NO.*	FIGURE NO.	TABLE NO.	RECOMMENDED CHANGES AND REASON <i>(Provide exact wording of recommended changes, if possible).</i>	
*Reference to line numbers within the paragraph or subparagraph.							
TYPED NAME, GRADE OR TITLE					TELEPHONE EXCHANGE/AUTOVON, PLUS EXTENSION		SIGNATURE

TO: <i>(Forward direct to addressee listed in publication)</i> U.S. Army TACOM Life Cycle Management Command ATTN: AMSTA-LCL-MPP / TECH PUBS, 1 Rock Island Arsenal Rock Island, IL 61299-7630	FROM: <i>(Activity and location) (Include ZIP Code)</i> Command	DATE
---	---	-------------

PART II – REPAIR PARTS AND SPECIAL TOOL LISTS AND SUPPLY CATALOGS/SUPPLY MANUALS

PUBLICATION NUMBER TM 9-1005-319-10	DATE 30 June 2010	TITLE Operator's Manual for Rifle, 5.56 MM (NSN 1005-01-128-9936), (NSN 1005-01-357-5112) and (NSN 1005-01-383-2872), Carbine, 5.56 MM (NSN 1005-01-231-0973) and (NSN 1005-01-382-0953)
---	-----------------------------	--

PAGE NO.	COLM NO.	LINE NO.	NATIONAL STOCK NUMBER	REFERENCE NO.	FIGURE NO.	ITEM NO.	TOTAL NO. OF MAJOR ITEMS SUPPORTED	RECOMMENDED ACTION

PART III – REMARKS

(Any general remarks or recommendations, or suggestions for improvement of publications and blank forms. Additional blank sheets may be used if more space is needed.)

--

TYPED NAME, GRADE OR TITLE	TELEPHONE EXCHANGE/AUTOVON, PLUS EXTENSION	SIGNATURE
-----------------------------------	---	------------------

RECOMMENDED CHANGES TO PUBLICATIONS AND BLANK FORMS						Use Part II (reverse) for Repair Parts and Special Tools Lists (RPSTL) and Supply Catalogs/Supply Manuals (SC/SM).	DATE
For use of this form, see AR 25-30; the proponent agency is ODISC4.							
TO: (Forward to proponent of publication or form) (Include ZIP Code) U.S. Army TACOM Life Cycle Management Command ATTN: AMSTA-LCL-MPP/TECH Pubs 1, Rock Island Arsenal, Rock Island, IL 61299-7630						FROM: (Activity and location) (Include ZIP Code)	
PART I - ALL PUBLICATIONS (EXCEPT RPSTL AND SC/SM) AND BLANK FORMS							
PUBLICATION/FORM NUMBER TM 9-1005-319-10					DATE 30 June 2010	TITLE Operator's Manual for Rifle, 5.56 MM (NSN 1005-01-128-9936), (NSN 1005-01-357-5112) and (NSN 1005-01-383-2872), Carbine, 5.56 MM (NSN 1005-01-231-0973) and (NSN 1005-01-382-0953)	
ITEM NO.	PAGE NO.	PARA-GRAPH	LINE NO.*	FIGURE NO.	TABLE NO.	RECOMMENDED CHANGES AND REASON <i>(Provide exact wording of recommended changes, if possible).</i>	
*Reference to line numbers within the paragraph or subparagraph.							
TYPED NAME, GRADE OR TITLE					TELEPHONE EXCHANGE/AUTOVON, PLUS EXTENSION	SIGNATURE	

TO: (Forward direct to addressee listed in publication) U.S. Army TACOM Life Cycle Management Command ATTN: AMSTA-LC-LMPP / TECH PUBS 1 Rock Island Arsenal, Rock Island, IL 61299-7630	FROM: (Activity and location) (Include ZIP Code) Your address Command	DATE Date you filled out this form
---	--	--

PART II – REPAIR PARTS AND SPECIAL TOOL LISTS AND SUPPLY CATALOGS/SUPPLY MANUALS		
PUBLICATION NUMBER TM 9-1005-319-10	DATE 30 June 2010	TITLE Operator's Manual for Rifle, 5.56 MM (NSN 1005-01-128-9936), (NSN 1005-01-357-5112) and (NSN 1005-01-383-2872), Carbine, 5.56 MM (NSN 1005-01-231-0973) and (NSN 1005-01-382-0953)

PAGE NO.	COLM NO.	LINE NO.	NATIONAL STOCK NUMBER	REFERENCE NO.	FIGURE NO.	ITEM NO.	TOTAL NO. OF MAJOR ITEMS SUPPORTED	RECOMMENDED ACTION

PART III – REMARKS <i>(Any general remarks or recommendations, or suggestions for improvement of publications and blank forms. Additional blank sheets may be used if more space is needed.)</i>

TYPED NAME, GRADE OR TITLE Your Name	TELEPHONE EXCHANGE/AUTOVON, PLUS EXTENSION	SIGNATURE Your Signature
---	--	-----------------------------

By Order of the Secretary of the Army:

GEORGE W. CASEY, JR.
General, United States Army
Chief of Staff

Official:



JOYCE E. MORROW
Administrative Assistant to the
Secretary of the Army
1014001

By Order of the Secretary of the Air Force: **NORTON A. SCHWARTZ**
General, United States Air Force
Chief of Staff

DONALD J. HOFFMAN
General, United States Air Force
Commander, AFMC

By Order of the Secretary of the Navy:

JERRY GASKILL
Small Arms Program Manager
Naval Sea Systems Command

DISTRIBUTION: To be distributed in accordance with the Initial Distribution Number (IDN) 400016 requirements for TM 9-1005-319-10.

PIN: 059875-000