

**LUDOWICI<sup>®</sup>**

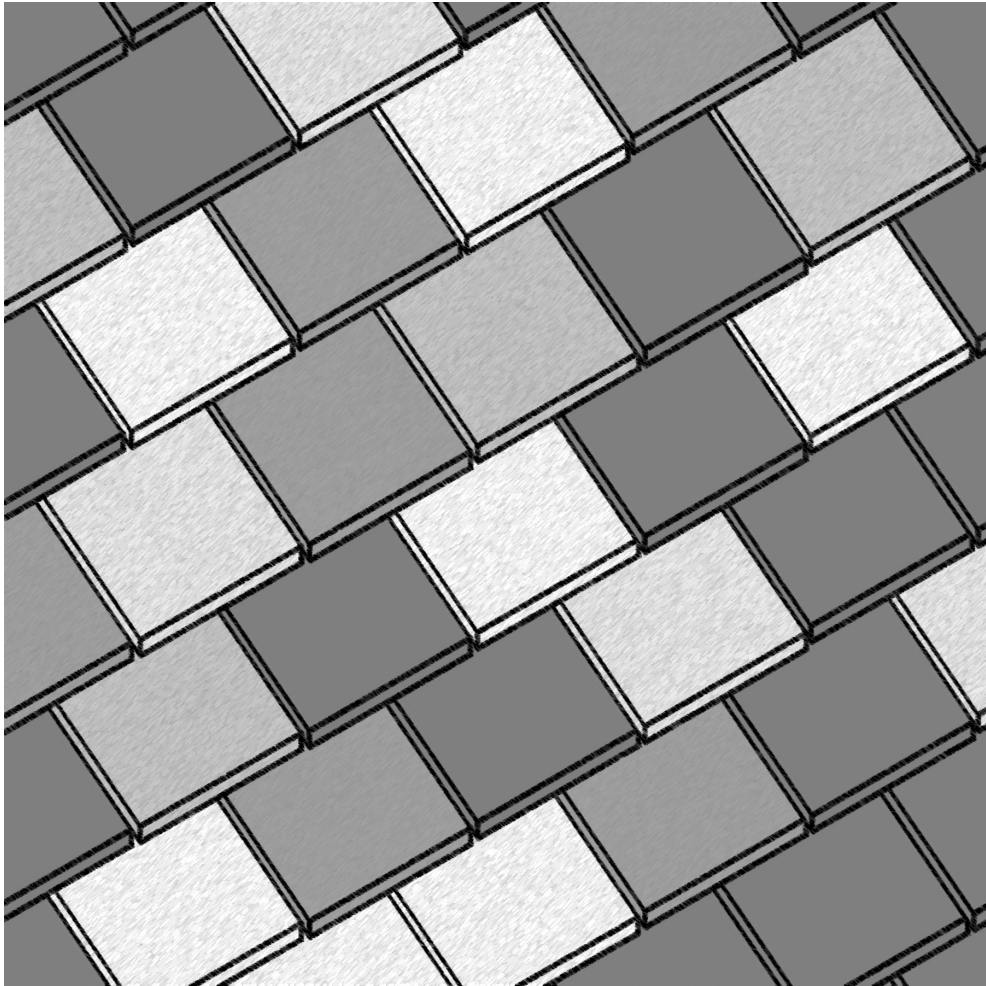

# **Shingle Tile Installation Manual**

[www.ludowici.com](http://www.ludowici.com)

## CLAY TILE ROOFING

has been in existence for over a millennium. In the last few decades, clay tile roof installation techniques have been refined to protect your project while retaining the aesthetic, “of the earth” characteristics that make up the roof’s appeal. The purpose of this manual is to provide technical information and installation instructions for Ludowici clay tile. It is intended to serve as a guide for proper techniques for typical installations. Ludowici clay tile is a versatile roofing material and can be applied on complex, original designed roofs. Installers are encouraged to contact Ludowici representatives for any question not covered in this manual. Some techniques may vary from region to region and other sound installation techniques may also be acceptable.

A Ludowici roof installed today will last over 100 years, be sure that all other roof components and installation techniques are as durable.

**Table of Contents**

---

4	<b>Physical Characteristics</b>
4	Field Tile
5	Fittings
6	Hip and Ridge
8	<b>Before Getting Started</b>
8	Roof Slope
8	Weight
8	Roof Deck
9	Underlayment
10	Fastening Methods
12	<b>Getting Started</b>
13	Preparing the Roof
13	Inspecting the Deck
13	Installing the Underlayment
14	Concrete Deck
14	Ice Dam Protection
15	Applying Cant Strips
16	Measuring and Chalking the Roof
18	Tile Distribution Over Deck
19	Cutting, Notching and Drilling
20	Blending
22	<b>Installing Flashing</b>
22	Eave
23	Rake
24	Valley
26	Vertical Wall
27	Dormer
28	Head Wall
29	Chimney
30	Skylights and Plumbing Vent
31	Pitch Change
32	<b>Flat Shingle Installation</b>
33	Under Eave
33	First and Succeeding Courses
34	Valley Tiles
35	Hip
38	Ridge
41	Vertical Wall
42	Layout and Staggering
43	Repair

## Field Tile Physical Characteristics

Chart 4.1 Rustic Field Tile Physical Characteristics

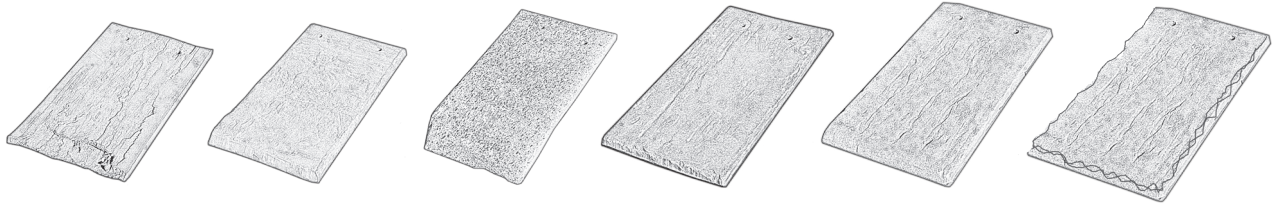

	<b>Antique</b>	<b>Brittany</b>	<b>Crude</b>	<b>Colonial</b>	<b>Rustic Colonial</b>	<b>Cotswold</b>
Weight/Square	1,650 lbs.	1,900 lbs.	1,935 lbs.	1,800 lbs.	1,800 lbs.	2,160 lbs.
Pieces/Square	412	412	480	310	310	317
Overall Size	7" x 12" x 1/2"	7" x 12" x 5/8"	6" x 12" x 5/8"	7-3/8" x 14-3/8" x 5/8"	7-3/8" x 14-3/8" x 5/8"	7-1/4" x 14-1/2" x 3/4"
Exposure	7" x 5"	7" x 5"	6" x 5"	7-3/8" x 6-5/16"	7-3/8" x 6-5/16"	7-1/4" x 6-1/4"
Minimum Slope	5:12	5:12	5:12	5:12	5:12	5:12

Chart 4.2 Formal Field Tile Physical Characteristics

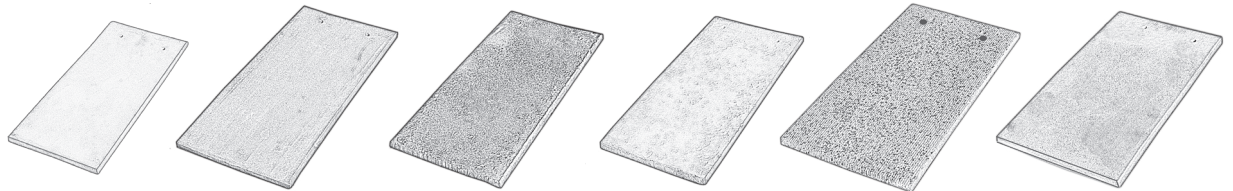

	<b>Flat Slab</b>	<b>Provincial</b>	<b>Norman</b>	<b>Calais</b>	<b>Georgian</b>	<b>Cottage</b>
Weight/Square	1,300 lbs. 1,780 lbs.	1,575 lbs.	1,600 lbs.	1,600 lbs.	1,600 lbs.	1,600 lbs.
Pieces/Square	480 480	317	317	317	276	276 247 222
Overall Size	6" x 12" x 3/8" 6" x 12" x 5/8"	7" x 15" x 1/2"	7" x 15" x 1/2"	7" x 15" x 1/2"	8" x 15" x 1/2"	8" x 15" x 1/2" 9" x 15" x 1/2" 10" x 15" x 1/2"
Exposure	6" x 5"	7" x 6-1/2"	7" x 6-1/2"	7" x 6-1/2"	8" x 6-1/2"	8" x 6-1/2" 9" x 6-1/2" 10" x 6-1/2"
Minimum Slope	5:12	5:12	5:12	5:12	5:12	5:12

## Fittings Physical Characteristics

Chart 5.1 Shingle Tile Fittings Physical Characteristics

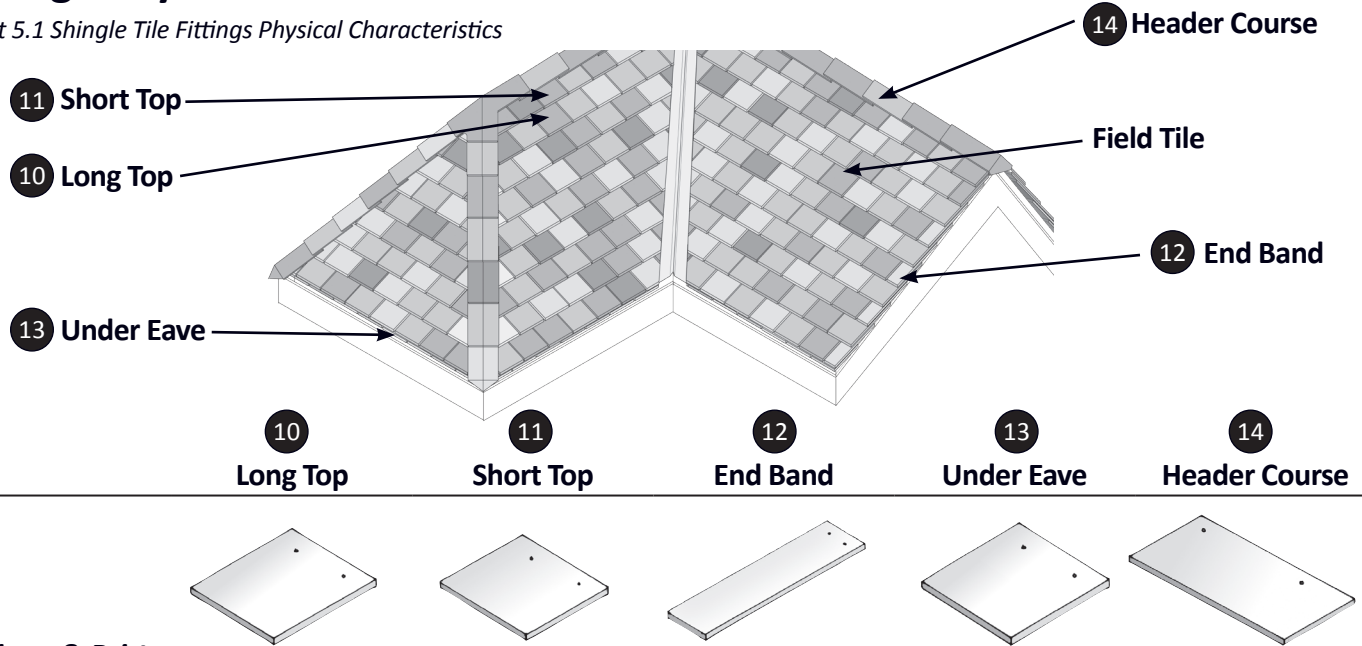

### ***Antique & Brittany***

	10 Long Top	11 Short Top	12 End Band	13 Under Eave	14 Header Course
Overall Size	7" x 9"	7" x 5"	3-1/2" x 12"	7" x 7"	7" x 12"
Exposure	7" x 5"	7" x 2"	3-1/2" x 5"	7"	7" x 9"
Weight/Pc.	3 lbs.	1.7 lbs.	2 lbs.	2.4 lbs.	4 lbs.

### ***Calais, Colonial, Rustic Colonial, Norman & Provincial***

	10 Long Top	11 Short Top	12 End Band	13 Under Eave	14 Header Course
Overall Size	7" x 10-1/2"	7" x 6-1/2"	3-1/2" x 15"	7" x 8-1/2"	7" x 15"
Exposure	7" x 6-1/2"	7" x 3-1/2"	3-1/2" x 6-1/2"	7"	7" x 12"
Weight/Pc.	4.2 lbs.	2.6 lbs.	2.9 lbs.	3.4 lbs.	5.8 lbs.

### ***Crude***

	10 Long Top	11 Short Top	12 End Band	13 Under Eave	14 Header Course
Overall Size	6" x 9"	6" x 5"	3" x 12"	6" x 7"	6" x 12"
Exposure	6" x 5"	6" x 2"	3" x 5"	6"	6" x 9"
Weight/Pc.	3.1 lbs.	1.7 lbs.	2.1 lbs.	3 lbs.	4.1 lbs.

### ***Georgian & Cottage***

	10 Long Top	11 Short Top	12 End Band	13 Under Eave	14 Header Course
Overall Size	8", 9" & 10" x 10-1/2"	8", 9" & 10" x 6-1/2"	4", 4-1/2" & 5" x 15"	8", 9", & 10" x 8-1/2"	8" x 15"
Exposure	8", 9" & 10" x 6-1/2"	8", 9" & 10" x 3-1/2"	4" x 6-1/2"	8"	8" x 12"
Weight/Pc.	4.2, 4.8, 5.3 lbs.	2.6, 2.9, 3.3 lbs.	2.9, 3.3, 3.7 lbs.	3.4, 3.9, 4.3 lbs.	5.8 lbs.

### ***Flat Slab 3/8" & 5/8"***

	10 Long Top	11 Short Top	12 End Band	13 Under Eave	14 Header Course
Overall Size	6" x 9"	6" x 5"	3" x 12"	6" x 7"	6" x 12"
Exposure	6" x 5"	6" x 2"	3" x 5"	6"	6" x 9"
Weight/Pc.	2.1, 2.8 lbs.	1.2, 2 lbs.	1.4, 1.9 lbs.	2, 2.7 lbs.	3.7 lbs.

## Hip and Ridge Physical Characteristics

Chart 6.1 Hip & Ridge Physical Characteristics

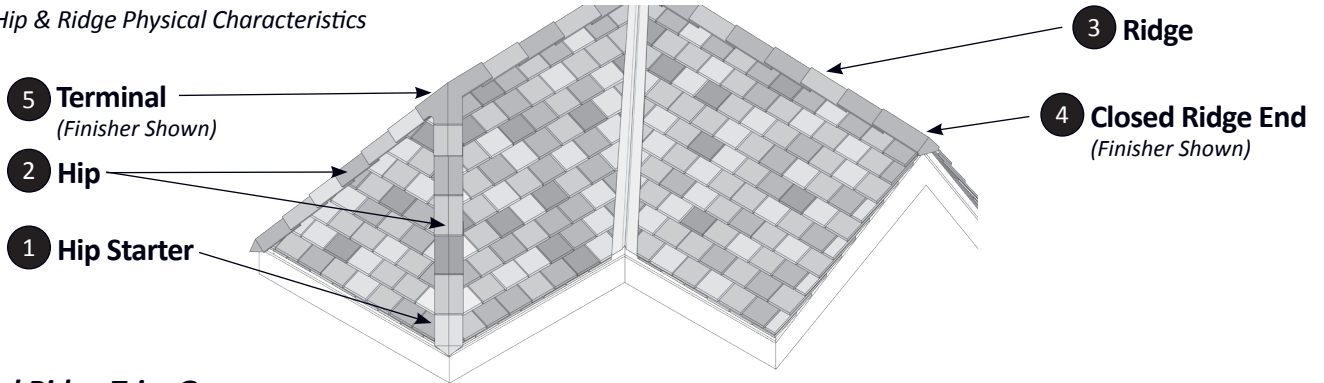

### V-Hip and Ridge Trim Group

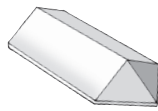

**1**  
Hip Starter



**2**  
V-Hip



**3**  
V-Ridge

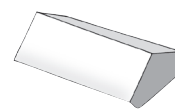

**4**  
V-Closed Ridge End

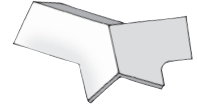

**5**  
V-Terminal\*

Overall Size	15-1/2"	14-1/4"	14-1/4"	14-1/4"	-
Exposure	12"	12"	12"	12"	-
Weight/Pc.	8 lbs.	8.8 lbs.	8.8 lbs.	8 lbs.	15 lbs.

#### V-Ridge Angles

Description	Degree	Roof Pitch
Regular	116°	3:12 to 10:12
Intermediate	90°	11:12 to 20:12
Steep	75°	20:12 +

#### V-Hip Angles

Degree	Roof Pitch
116°	3:12 to 18:12

### 118/211 Hip and Ridge Trim Group

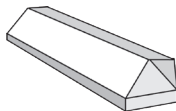

**1**  
Hip Starter

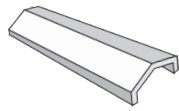

**2**  
118 Hip Roll

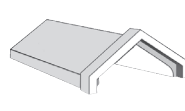

**3**  
211 Ridge

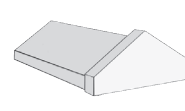

**4**  
211 Closed Ridge End  
(Starter Shown)

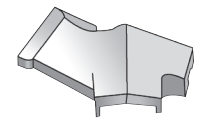

**5**  
118/211  
Terminal\*  
(Finisher Shown)

Overall Size	14"	14"	13-1/4"	13-1/4"	-
Exposure	12"	12"	12"	12"	-
Weight/Pc.	5 lbs.	4.8 lbs.	9.7 lbs.	14 lbs.	20 lbs.

#### 211 Ridge Angles

Description	Angle	Roof Pitch
Regular	116°	3:12 to 10:12
Intermediate	90°	11:12 to 20:12
Steep	75°	20:12 +

\*Ludowici makes ridge/hip terminals to fit any roof geometry. Contact your Ludowici representative for assistance.

Chart 7.1 Hip & Ridge Physical Characteristics

**Circular Cover Hip and Ridge Trim Group**

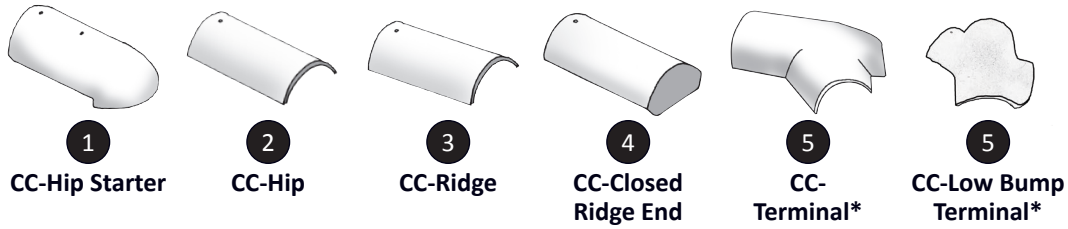

Overall Size	15-1/2"	16"	16"	14-1/4"	-	-
Exposure	12"	13"	13"	12"	-	-
Weight/Pc.	9 lbs.	5.8 lbs.	5.8 lbs.	9.8 lbs.	15 lbs./pc.	25 lbs.

**102/206 Hip and Ridge Trim Group**

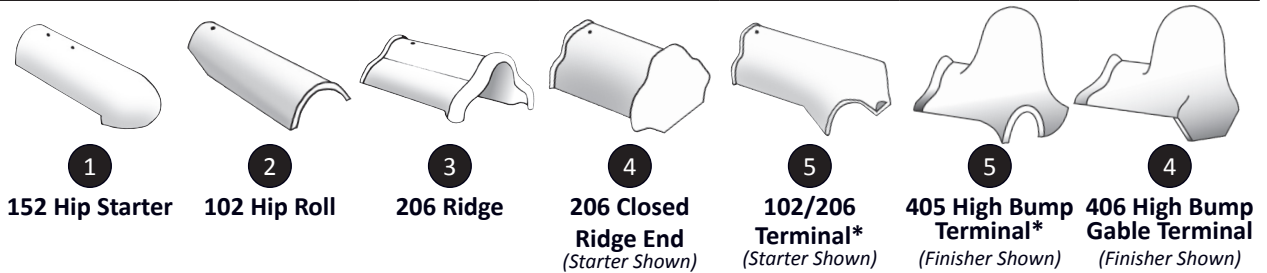

Overall Size	14"	14"	13-1/4"	13-1/4"	-	-	-
Exposure	12"	12"	12"	12"	-	-	-
Weight/Pc.	6.3 lbs.	6.2 lbs.	11.5 lbs.	18 lbs.	17 lbs.	35 lbs.	30 lbs.

**Old Style Trim Group**

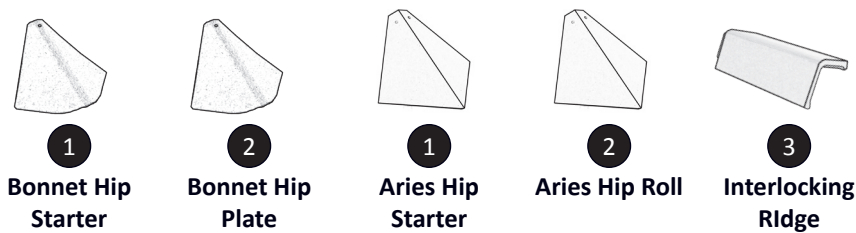

Overall Size	**	**	**	**	16-3/4"
Exposure	***	***	***	***	16"
Weight/Pc.	5 lbs.	5 lbs.	5 lbs.	5 lbs.	8.9 lbs.

**NOTE: The use of Bonnet and Aries Hip Plate requires the same roof pitch on both sides of the hip.**

*\*Ludowici makes ridge/hip terminals to fit any roof geometry. Contact your Ludowici representative for assistance.*

*\*\*Overall length depends on field tile profile.*

*\*\*\*Exposure depends on profile and roof pitch.*

# Before Getting Started

## Roof Slope

Ludowici Roof Tile's recommended minimum slope requirements for Shingle tile is 5:12. **No clay tile roofs are to be installed below a roof slope of 3:12.**

*There is no maximum slope requirement for tile roofs. However, on extremely steep (above 19:12) or vertical applications, wind current may cause the tiles to rattle. To avoid this, set the butt of each tile with a bead of sealant where it will not be seen.*

### **IMPORTANT:**

**On low pitches, from 3:12 to the standard recommended product minimums, it is required to apply a layer of Ice and Water Shield or waterproofing underlayment that meets or exceeds ASTM D1970, on the entire deck. Adequate ventilation will be required.**

## Weight

Proper roof framing is required to carry the weight of a tile roof. The weight of one square (100 sq. ft.) of Shingle tile will range from 1,300 pounds to over 2,200 pounds. The weight of the roof tile is determined by the type and size of the tile and the exposure of each course of tile. Reducing the exposure of the tile will increase the roof load.

The weight of the underlayment, fastening system, roof accessories and trim tile also needs to be considered when determining the total weight. Check dead load allowances of the applicable local building codes.

It is recommended that the structural design of the roof be evaluated by a registered engineer to determine that it can support the load; most building codes require an engineering review. Getting a written letter of approval is suggested and may be required by local building codes.

If the installation is in a region of seismic activity or heavy wind load, local building codes must be consulted for additional requirements.

## Roof Deck

A design standard for roofing decks is to have a **maximum deflection of L/240 between supports**. A deck will be exposed to live and dead loads. A live load is one that will only be exerting pressure on the roof deck for a short time. Example; Snow or wind loads. A dead load is one that will exert a constant pressure to the roof deck; i.e., underlayments, tile and battens.

**Fastener Pullout Resistance:** Minimum average fastener pullout resistance for clay roofing tile is 180 lbs., with no single value less than 170 lbs. Greater pullout values may be required depending upon the predicted aerodynamic moment expected for the tile shape, building shape and the proximity to the coastline. An engineer should be consulted to assure local building code compliance.

**For Board Plank Deck:** Use well-seasoned plank board (1" full thickness, maximum 6" nominal width) that is not prone to warping, cupping or twisting.

**For Plywood Deck:** APA rated plywood is required for a minimum of 3/4" thick wood decking and must be rated for structural use as roof sheathing. The expansion crack between panels shall be at least 1/16" but no greater than 1/8". H-clips are to be used when rafters are spaced greater than 16" on center, to hold the side joints of the plywood together between supports. Unsupported end joints must be blocked.

**Nailable Concrete Decks:** Nailable concrete decks over time may lose their plastic nature, which allows direct nailing. For old decking material, a pullout test should be performed to determine the usefulness of the deck and the appropriate fastener. An engineer should be consulted to assure local building code compliance.

**Non-Nailable Concrete Decks:** For concrete decks that will not accept direct nailing, nailer boards are required. Attachment strips that allow the tile to be fastened to them should be pressure treated wood. These may be a board and batten system or pressure treated wood strips. Other



means of attaching tile to a concrete deck include wire-tie systems, foam adhesive and expanding nail-in anchors.

**NOTE: Ludowici does not recommend applying tile over spaced board sheathing or open battens.**

## Underlayment

Most problems with water-shedding roof installations occur from water that migrates through the joints of the tiles through capillary action, wind driven rain and runoff or ice damming. Because of this possibility, the underlayment is critical to the success of the roof. It is the architect or building owner’s responsibility to select an underlayment product that is suitable to specific location, climate, roof pitch and attic ventilation. When selecting an underlayment remember that Ludowici roof tiles are expected to last over 75 years so the underlayment should be of a comparable lifespan and quality.

Ludowici recommends the following for minimum underlayment:

- All decks shall be covered with two layers of No. 30# asphalt-impregnated roofing felt or one layer of No. 43# coated base sheet or one layer of Ice and Water Shield.

**NOTE: When using non-breathing Ice and Water Shield underlayments to cover the entire roof, the attic space MUST be properly ventilated to prevent moisture buildup.**

- All hips, valleys, rakes and ridges shall be covered with a waterproof underlayment, example; Ice and Water Shield or two layers of No. 43# coated base sheet.
- For proper ice dam protection a layer of Ice and Water Shield underlayment should be installed from the eave to a point 24” beyond the inside of the exterior wall. See page 14 for more information on ice dam protection.

**NOTE: Roofing felt should meet or exceed ASTM standards D226/D2626. Self adhered Modified should meet or exceed ASTM D1970.**

Chart 9.1 Underlayment Characteristics

Type	Pros	Cons
Asphalt Roofing Felt	<ul style="list-style-type: none"> <li>• Long track record</li> <li>• Well suited for most applications</li> <li>• Readily available</li> <li>• Breathable</li> <li>• Less expensive than Synthetics or Self Adhered</li> </ul>	<ul style="list-style-type: none"> <li>• Doesn’t seal around the nail holes</li> <li>• Not as effective on lower pitches</li> <li>• Can tear</li> <li>• Not suitable for long duration exposure directly to the elements</li> </ul>
Ice & Water Shield (Self Adhered Polymer-Modified Bituminous Sheet)	<ul style="list-style-type: none"> <li>• Rubberized material seals around nail holes</li> <li>• Self adhering materials creates a more monolithic water barrier</li> <li>• Ideal for low slope applications</li> </ul>	<ul style="list-style-type: none"> <li>• More expensive</li> <li>• <b>Non breathing requires good attic ventilation</b></li> <li>• Can be damaged by UV if exposed for 180+ days</li> </ul>
Synthetic Underlayments	<ul style="list-style-type: none"> <li>• Purported life span and durability</li> <li>• Some Synthetics are breathable</li> </ul>	<ul style="list-style-type: none"> <li>• Unproven. Most products have been on the market less than 20 years.</li> <li>• Two to three times cost of felt</li> </ul>

## Fastening Methods

Attachment requirements and fastener length are referenced in Chart 11.2

**Nails or Screws:** Nails are the most commonly used fastener for attaching clay tiles. Nails for tiles and cleats must be copper or stainless steel, 11 gauge minimum, .285"-.312" head minimum and proper length to give good penetration. Screws must be stainless steel or brass, #8 or #9 with a minimum .285"-.312" diameter head.

**NOTE: The use of Galvanized, Ceramic coated or any other fastener not mentioned above is not acceptable to Ludowici. All components of the roof should have an expected lifespan of 75+ years.**

**NOTE: Each Shingle field tile is provided with (2) two fastening nail holes. When installing field tiles, care should be taken to fasten each tile with nails or screws in every provided fastening hole.**

- For a plywood deck, use ring shank copper nails of the specified length to assure good penetration through under side of deck (see Chart 11.2).
- For board plank deck, use smooth shank copper nails of the specified length. Fasteners should penetrate deck board 3/4". Do not penetrate underside of deck.
- For gypsum plank or nailable concrete deck, use stainless steel or silicon bronze screw shank nails of length to penetrate half to three-quarters the thickness of the deck. Never penetrate underside of deck.
- When insulation is applied over the deck, observe the following:
  - Minimum slope to 5:12 - The tile can be nailed through underlayment and insulation into the deck with a sufficient length fastener.
  - On 6:12 or greater, a tile-tie system should be used.
- For metal decks, use sheet metal screws and the proper mastic.

- For fibrous cement decks, use a tile-tie system.  
**NOTE: When using stainless steel screws, tile replacement will require the use of a hack saw to remove the screws. A slate ripper may be used with copper or brass fasteners.**

**Wire:** On non-nailable surfaces or some insulated decks or where fastening through the metal flashing needs to be avoided or if underlayment cannot be penetrated, such as special low slope applications, wire and strapping systems are sometimes used. Wire must be 13 gauge stainless steel or 10 gauge solid copper, with or without insulation. Wire-tieing is also usually specified in areas prone to earthquakes. Consult Newportfastener.com for specific design and installation assistance.

**Clips:** Wind clips are often specified and/or required in high wind and seismic areas. They aid in holding the tiles in place and reduce stress at the preliminary fastening point. Refer to local building codes in such areas.

**NOTE: In high wind regions, install each tile with #8 or #9 stainless steel or brass flathead Phillips or square drive screws . A 1" diameter dab of sealant or roofing cement at the tile lap can also be applied.**

**Bedding Tile:** Where freeze-thaw cycles are not an issue, tile may be laid in a full or partial bed of mortar. This method is best used in combination with other means of attachment.

**Foam Adhesive:** This method of application is approved for use in Sun Belt non freeze-thaw areas and is being tested for use in other areas. Refer to local building codes. Do not use single part foam systems with Ludowici tile. Only two part systems such as Polyset® from Polyfoam are acceptable. Visit Polyfoam.cc for design and installation assistance.

**IMPORTANT:**  
**Before application of Ludowici tiles in alpine conditions, plans must be submitted to the Ludowici Technical Department for approval. Ludowici will not assume liability or responsibility for damage caused by the application of clay tiles in alpine conditions.**

Figure 11.1 Proper Nailing Techniques for Plywood Decks

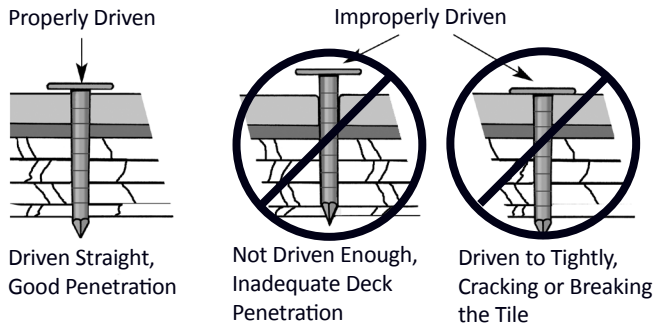

Chart 11.2 Attachment Requirements

***Antique, Brittany, Calais, Crude, Colonial, Rustic Colonial, Cottage, Flat Slab 3/8", Georgian, Norman & Provincial***

Substrate	Field Tile	Hip	Ridge	Quik-Tach™ Bracket
Boards	1-1/2"	2"	Header Course 1-1/2"	Type C*
3/4" Plywood	1-3/4"	2"	Other Types 2-1/2"	Type C*

***Flat Slab 5/8" & Cotswold***

Substrate	Field Tile	Hip	Ridge	Quik-Tach™ Bracket
Boards	1-3/4"	2"	Header Course 1-1/2"	Type C*
3/4" Plywood	2"	2"	Other Types 2-1/2"	Type C*

\* Type C brackets must be cut or bent for these tile patterns

# Getting Started

## Assemble All Tools and Supplies

The following tools are needed for basic installation of clay roofs:

- Safety equipment as required by OSHA and other local and state agencies
- Rule or tape
- Mason's trowel and bucket
- Chalk line and chalk
- 4" diamond-tipped turbo blade on angle grinder
- Claw hammer
- Protective eye wear/dust mask
- Chipping hammer
- Caulking gun
- Felt knife
- Sheet metal shears
- Roof jacks
- Slate ripper
- Segmented diamond blade (8" to 10" diameter)
- Wet tub saw
- Tile nippers
- Marking pencil
- Sharp steel punch
- Battery-operated, clutch-driven drill (with extra batteries)
- Carbide spear point glass drill bits
- Small steel roller

### **IMPORTANT:**

**All roof work can be hazardous. Safety requirements are spelled out by OSHA and individual state Occupational Safety and Health Administration regulations. It is the responsibility of the installer to take all necessary precautions. Contact the Occupational Safety and Health Administration for complete information.**

### **IMPORTANT:**

**All roofing components should be selected to be compatible with the long service life of a Ludowici roof.**

In addition to tools, the following materials are needed:

- Flashing: use a minimum weight of 16 oz. copper, at least 24" wide, with 1/4" edge turned over and fastened with cleats for valleys. Under special circumstances, such as unusual exposure to high wind or heavy snow, this flashing weight should be increased. Lighter weight copper flashings are undesirable because they can puncture too easily and they will not provide the wear life required for a long-life roof system.
- Underlayment: two layers of No. 30# asphalt-impregnated roofing felt or one layer of No. 43# coated base sheet, doubled on rough surfaces, hips, valleys and ridges, or one layer of Ice and Water Shield.
- Roofing cement: roofing cement for gable rakes, hip rolls, ridges, stringers and other conditions should be non-running, heavy-body flashing cement composed of mineral ingredients to meet the requirements of ASTM D-4586.
- Cant strips, wood nailers and field tile nailer strips: all should be foundation grade wood.
- Mortar and mortar color to match tiles: Ludowici defines mortar as one part Portland cement and four parts sand (to ASTM specification C-270). Contact your local brick distributor to acquire colorant.
- Silicone sealant or adhesive: the recommended sealant for exposed caulking is Dow Corning<sup>®</sup> 790 Silicone Building Sealant<sup>™</sup> or GE<sup>®</sup> SilProof<sup>™</sup> (ASTM C-920, low modulus). These sealants may be used as hidden adhesives. NP1 or other adhesives may be suitable as well; however, care should be taken to select for maximum durability and also for compatibility with adjacent materials. Some sealants are available in different colors to match tiles.

# Preparing the Roof

## Inspecting the Deck

- Ensure that the roof deck is clean, smooth and dry before roof tiles are applied.
- Verify that there is no significant delamination, warpage, bowing or separation from the rafters or trusses. Check for deck rot.
- If deck is APA 3/4" rated plywood, check that panels are spaced approximately 1/16" to a maximum of 1/8" apart for expansion and H-clips are used between supports when the rafter spacing exceeds 16" O.C. Unsupported end joints must be blocked.
- Make repairs to the deck as necessary.

**NOTE:** Prior to applying any roofing material, all contractor work above the roofline must be completed.

## Installing the Underlayment

Most problems with water-shedding roof installations occur from water that migrates through the joints of the tiles through capillary action, wind-driven rain and runoff or ice damming. Because of this possibility, the underlayment is critical to the success of the roof.

At a minimum, all decks must be covered with two layers of No. 30# asphalt-impregnated roofing felt or one layer of No. 43# coated base sheet.

**NOTE:** Underlayment materials must be covered with tile as soon as possible to prevent degradation from exposure.

If wood cant strips and nailers are nailed directly to the deck, they must be covered with waterproof underlayment. If nailed on the underlayment, they should be pressure treated wood.

**NOTE:** All roofing underlayment materials should be carried 6" up all vertical surfaces.

**For single layer of No. 43# coated base sheet:**

Lay base sheet parallel to eave. Side lap - 2" and end lap - 6".

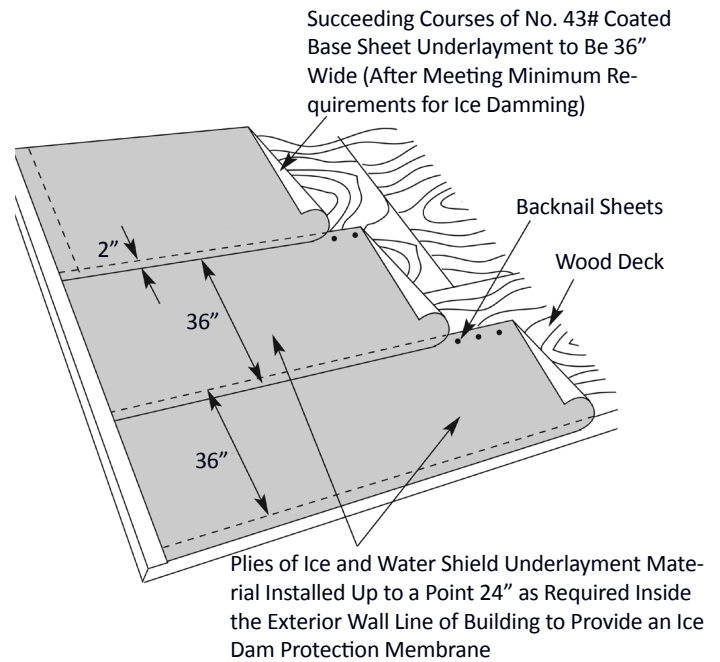

**NOTE:** All Dimensions are Approximate

Figure 13.1 Single Sheet Underlayment

**For Double Layers, follow these steps:**

First apply a starter sheet of 1 layer of Ice and Water Shield underlayment per manufacturer's instructions.

Then completely cover the starter sheet with a full-width sheet of No. 43# roofing felt. Lap succeeding sheets 19" over the preceding sheets, leaving a 17" exposure (2" lap). End laps should be a minimum of 6" (see Figure 13.2).

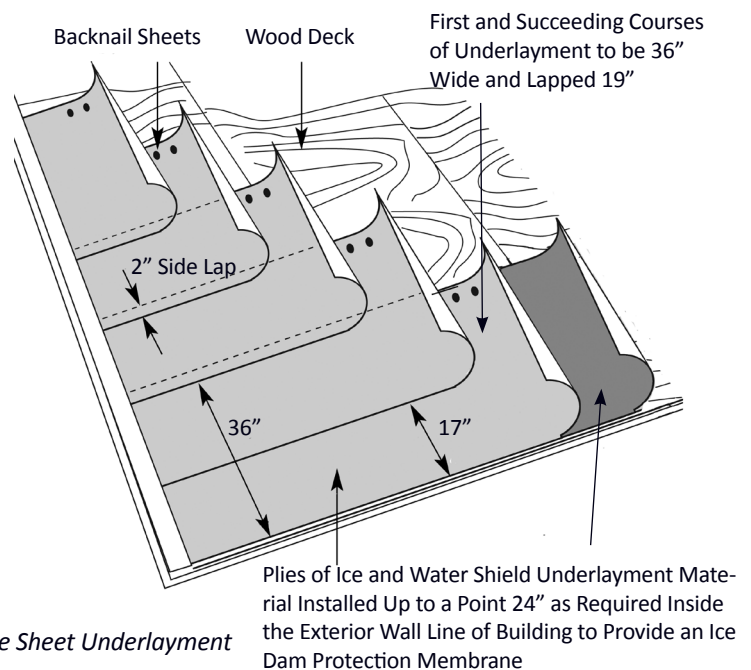

Figure 13.2 Double Sheet Underlayment

## Concrete Deck

For Ice and Water Shield underlayments follow the manufacturer's installation instructions for attachment to concrete. Or, if using asphalt felt apply No. 43# coated base sheet and fasten per the architect's instructions. For non-nailable concrete decks a counter batten system will be necessary. Over the underlayment fasten a standard pressure treated 1" x 2" furring strip vertically 20" O.C., apply pressure treated 1" x 2" wood strips horizontally across lath spaced to accommodate the correct tile exposure and proceed as directed for a sheathed roof (see Figure 14.1).

**NOTE: Flashing dimensions will have to be adjusted to accommodate the thicker assembly.**

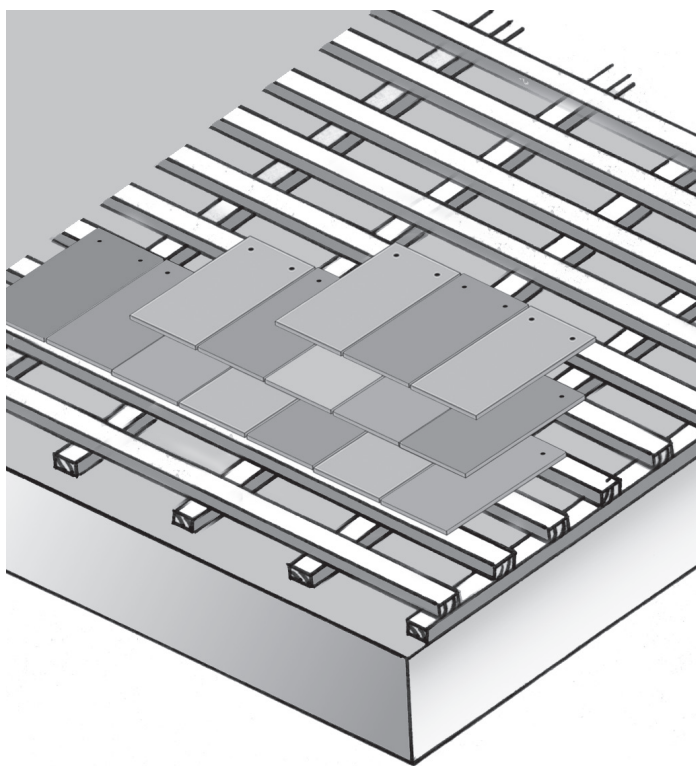

Figure 14.1 Batten System of Attachment for Concrete Deck

## Ice Dam Protection

Ice dam protection is recommended in areas where the January mean temperature is 30° F. or less and on all pitches below the standard minimums. This protection must be installed wherever there is a possibility of ice forming along the eaves which will cause a back-up of water and may cause building and interior damage. Consider your local weather conditions.

Apply self-adhering Ice and Water Shield, or equivalent, directly to the deck according to application instructions provided with the product. Self-adhering underlayment must extend up the roof to a point at least 24" beyond the interior wall line and in areas of severe icing at least up to and above the highest water level expected to occur from ice dams (see Figure 14.2).

**Please note that the 24" point beyond the interior wall line is a minimum recommendation. Self-adhering Ice and Water Shield underlayment should be applied to all roof decking, which past history and professional experience suggest, might be subject to ice dam back-up. If considering using ice dam protection on the entire surface of the roof deck, insure that adequate ventilation is present to prevent the development of damaging condensation on the underside of the roof deck.**

If a wide eave overhang requires flashing wider than 36", the necessary 6" minimum horizontal lap must be located on the overhang outside the structure walls. End laps must be a 6" minimum. Underlayment should meet ASTM D-1970.

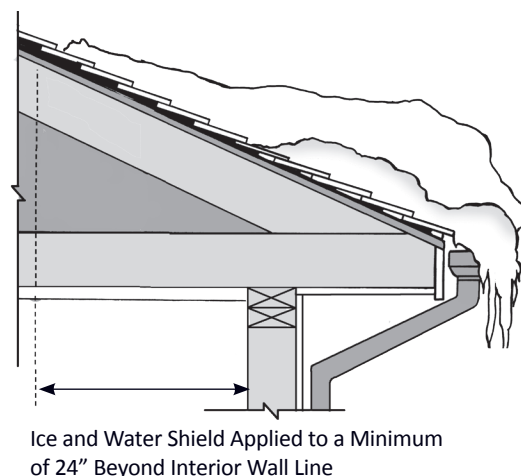

Figure 14.2 Ice Dam Protection

## Applying Cant Strips, Wood Nailers and Battens

After lining the roof with underlayment install wood stringers for ridges and hips, cant strips at eaves and battens as field tile nailer strips (required for certain applications). The heights of the stringers, battens and cant strips are determined by the tile pattern and the type of fittings to be used.

### Cant Strips

Apply a properly sized cant strip (see Chart 15.1) 48" long and pressure treated directly to the underlayment, with 1/2" gap every 96" to allow drainage. Cover with copper flashing drip edge and a 6" Strip of Self Adhering Ice and Water Shield.

**For Shingle tiles, both the cant strip and an under eave fitting are used.**

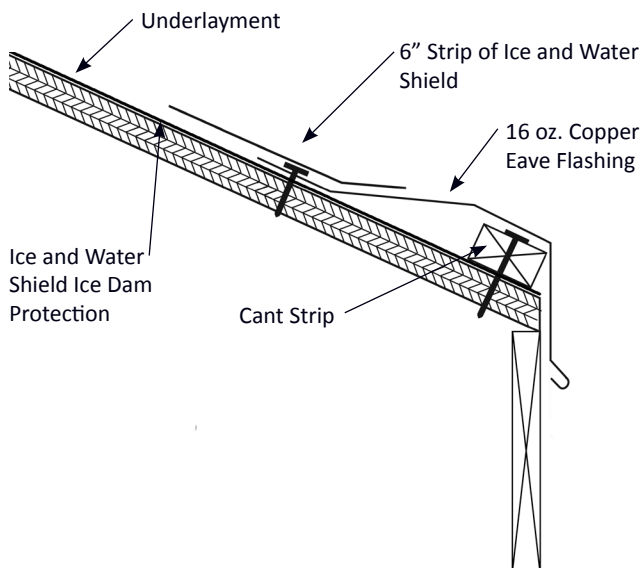

Figure 15.2 Copper Flashing Eave Detail

### Tile Style Nominal Size of Cant Strip

Flat Slab Shingle 3/8"	3/4" x 2"
Flat Slab Shingle 5/8" Antique, Brittany, Calais, Colonial, Rustic Colonial, Cotswold, Cottage, Crude, Georgian, Norman and Provincial	1" x 2"

Chart 15.1 Proper Sizing for Cant Strips

### Stringers for Hip and Ridge

Attached Ridge and Hip Stringers with corrosion resistant fasteners 2' O.C. (See Figure 16.1).

All wood stringers must be covered with two layers of coated base sheet or a self-adhesive Ice and Water Shield. Stringers must be pressure treated and foundation grade wood. The sizes for stringers vary with tile and Ridge Cap type. Wood stringers must be a minimum of 1-1/2" thickness and of proper height to carry hip and ridge pieces.

Stringer height for hip and ridge vary depending on the tile profile, hip and ridge type and roof pitch. To determine proper stringer heights for your application lay field tile and hip on the roof deck in the correct configuration and measure the gap between the underside of the hip tile to the apex of the hip on the roof deck, this will be your stringer height.

**NOTE: Hip caps should just rest on the bottom edge of the field tile and run in a straight line parallel to the roof slope.**

Follow the same procedure for the ridge stringer. For Vented Ridge adjust Ridge Riser Bracket to correct height.

Even on conditions where the stringer height is minimal it is important to install them to provide a straight surface for the hip tile to rest. Do not eliminate the stringer and just let the hip tile rest on the field tile. This will produce an irregular hip that snakes up and down.

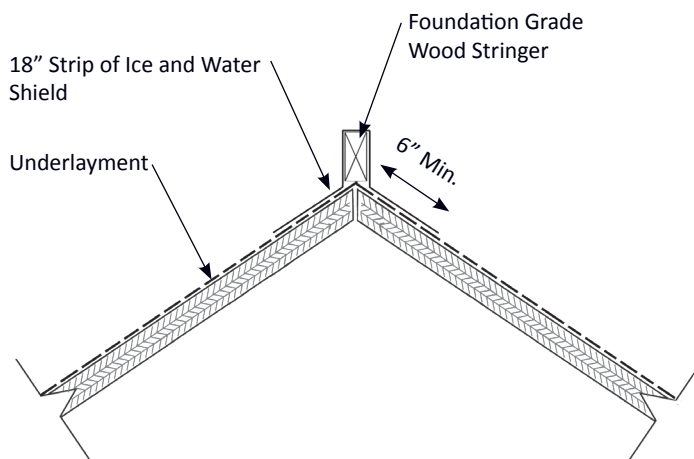

Figure 16.1 Ridge and Hip Stringer Detail

### Battens

For applications where Battens are specified, use nominal 1" x 2" pressure treated wood. Vertical battens should be spaced no further than 20" on center. Horizontal battens are applied one per course of tiles (See Fig 14.1).

## Measuring and Chalking the Roof

Layout and chalking the roof accurately are critical to the roof's performance and appearance. If the eaves are straight and level, all horizontal lines must be parallel to the eaves and all vertical lines must be perpendicular to the eaves. Check the roof deck to determine if the deck is square prior to layout.

### Step 1: Determine Width and Length Exposure

Clay tiles, depending on the style and profile, vary in exposure and recommended head lap. Ludowici Shingle tiles are laid with a minimum headlap of 2". Before chalking the roof the installer should verify the tile pattern being installed, and measure, noting average length and width exposures of the tile shipped.

**NOTE: The length of Ludowici's Rustic Shingle tiles intentionally varies by up to 1/2". The Roofer should take this into account when determining exposure being sure to maintain the 2" minimum headlap.**

**The width exposure should also include the spacing gap between tiles. Shingle tiles are typically laid with a gap the thickness of a copper roofing nail or about 3/32"; however, they can be laid with a gap up to 1/4". The usual overhang at the eave is 2"; however, this may be adjusted slightly to accommodate full courses.**

### Step 2: Chalking Vertical Lines

Vertical lines are charked first. In the case of a hip roof, the first line is struck in the center of the roof equidistant from each hip. The remaining vertical lines are then struck to the right and left at intervals equal to your average width exposure x 5. Care must be taken to ensure that all vertical lines are parallel to the water flow. For roofs with gables at both ends the horizontal exposure should be adjusted to work out to full tile or half tile to reduce cutting.

**NOTE: Vertical lines are not needed with random width Cottage or Georgian tile.**



**Step 3: Chalking Horizontal Lines**

Horizontal lines are struck after the vertical lines are struck. For Shingle tile the first line will equal the average length of the under eave tile minus the overhang (Typically 2”).

Length exposure of Shingle tile is determined by subtracting 2” (for headlap) from the tile length and dividing by 2.

Example:

$$12'' \text{ length} - 2'' \text{ headlap} = 10'' \div 2 = 5'' \text{ exposure}$$

For Shingle tile, the second line will equal the average length exposure minus the overhang, laid directly over the under eave. Measure from the eave line when striking the first full course line. Successive lines are then struck at intervals equal to your average length of exposure. Your eave to ridge measurement may determine the average length exposure rather than the size of the tile itself. Vertical exposure should be adjusted to work out to full tiles allowing for the use of Long and Short tops at the ridge.

Roofers should take this into account when spacing chalk lines.

**NOTE: Do not adjust exposure to a headlap less than 2”.**

Care must be taken to ensure that all horizontal lines are perpendicular to the water flow.

**IMPORTANT:**  
*The tile dimensions can vary because of clay firing temperatures. Be sure to measure tiles in your shipment to determine their average width and length dimensions, so you can chalk your roof properly.*

Ridges using a Header course do not use Short tops.

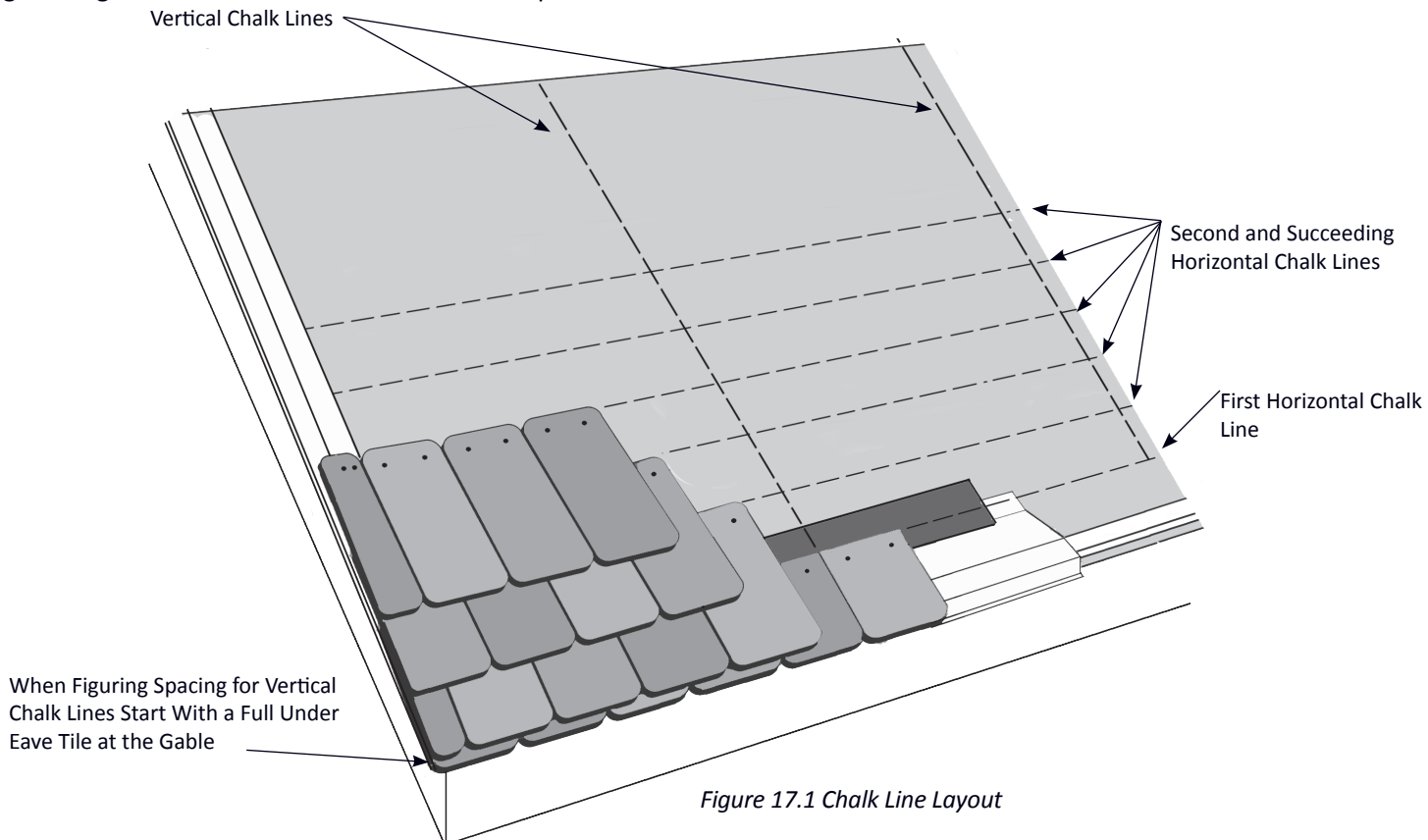

Figure 17.1 Chalk Line Layout

## Tile Distribution Over Deck

After all roof preparation has been completed, the tiles are evenly distributed on the roof, if pitch permits.

**NOTE:** *Stacking distribution will depend on the number of tiles per square and the number of tiles per stack.*

Spacing of the tiles is determined by the width of the exposed tile times the number of courses being fed per stack. If the tiles are stacked 8 tiles high and the tile exposure is 10" and the stack feeds 2 courses, then the stacks would be placed 40" O.C.

Tile stacks normally start at the third course from the eave and continue with alternate courses.

The important aspect of tile loading is to evenly spread the load across all surfaces of the roof using the proper spacing to assure the proper amount of tile is loaded on the roof.

**Whether a single color roof or multi color, the tile stacks should be pre-blended before roof loading. (See Page 20 for blending instructions.)**

### **WARNING:**

**Do not leave stacked tiles on the roof for extended periods of time. The concentrated load can begin to slide on the heated underlayment sheet. This sliding could cause injury to persons or damage to nearby property.**

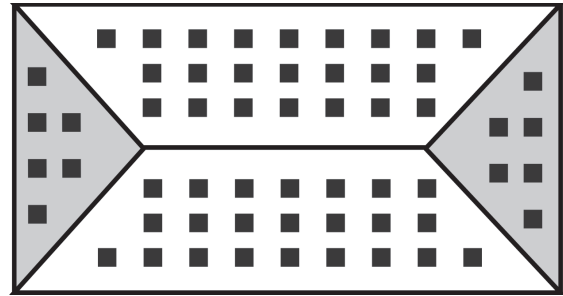

Figure 18.1 Distribution of Tile Over Roof

### **WARNING:**

#### **Roof Loaded Tile During Severe Weather**

It is possible that strong winds could lift tiles off the piles and send them flying off the roof, resulting in injury to persons or damage to nearby property.

- If tiles have been pre-loaded onto the roof deck and strong winds or severe storms are predicted, remove the tiles and place them on ground level.
- If tiles have not yet been loaded, then it is recommended not to do so until the threat of bad weather has disappeared.

Pre-loading the roof deck with tiles prior to starting the actual installation will provide convenience and faster installation, but should only be done if weather conditions permit. Use common sense so that you do not become liable for damage or personal injury.

## Cutting, Notching and Drilling

### Cutting

**NOTE:** *Unnecessary cutting and drilling time can add substantial cost to the job. Carefully consider tile layout before starting the work to minimize cutting and drilling.*

Tiles should be cut wet the way on the job with a masonry or tile saw equipped with a diamond blade. Segmented blades will be the most efficient. Slight surface chipping will occur during the cutting operation. The sliding saw table and tub should be as large as possible to accommodate cutting the tiles diagonally.

Ludowici tiles are extremely hard, which provides the tiles with low moisture absorption and long life. Dry cutting techniques used on softer tile products will not work as fast with Ludowici's hard tile. Dry cutting with a good segmented "turbo" diamond blade is possible. Best results have been obtained using a 4" diamond tipped segmented blade mounted on a small right angle grinder motor.

### Notching

One time saving option to drilling through the tiles is to notch it with the small 4" diamond blade saw and then nail or wire in place. If using a field tile for the starter course or ridge, "dovetail" notches are cut. Make sure cuts are wide enough for a nail or screw (see Figure 19.1).

### Drilling

Additional nail holes may also be drilled if necessary. High torque electric drills may snap the carbide bits in the extremely hard Ludowici tile. Drills should be battery-powered, adjustable clutch-driven types. To drill out holes, the tile should be set in a pan with water to extend bit life and avoid the risk of eye injury due to fragments. Expect to drill only about 6 holes per carbide bit.

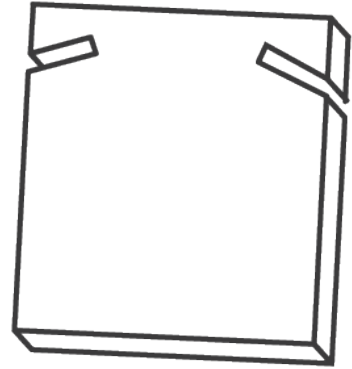

Figure 19.1 Examples of Cut and Notched Tile

### **WARNING:**

***Dry drilling may result in serious eye injury. Always use protective eye and face wear when drilling tile or operating a masonry saw.***

***Never use 115-240 volt AC-operated drills in water. Electrical shock could result.***

## Blending

Blending is one of the most important aspects of correctly installing a Ludowici tile roof.

***Whether installing a single color or multiple colors ALL LUDOWICI ROOFS MUST BE BLENDED.***

Colors within a given shipment of Ludowici clay roof tile will vary slightly due to subtle changes in clay composition and kiln firing temperatures. Such color variances are not a defect but a natural desirable feature that gives roofs depth and character.

Unless the architect or owner specifies a pattern, there should be no visible pattern or hot spots on the roof.

Ludowici does not pre-blend the tile. It is the roofers responsibility to evaluate the tiles for color shade and range and then properly blend them to achieve a harmonious color roof without blotches, hotspots or patterns.

The person responsible for the blending of the shades of color should randomly select tiles from at least four different pallets.

After the installation of about 75-100 tiles, the roof should be inspected from the ground at a distance greater than 40 feet to determine that there are no streaks or blotches. To ensure a good range of tones, this inspection must be done at regular intervals.

***NOTE: When nearing the end of the project if its determined that additional material will be needed to complete the roof, reserve several pallets of the initial shipment to blend with later shipments to maintain a consistent range.***

## Color Blending with Different Color Tile

Blending different tile colors can provide a unique and aesthetically pleasing roof.

Make a drawing to detail the layout and to help determine the proper number of tiles of each color.

In order to maintain the correct color blend, pull tiles from the different pallets of each color. Premix these piles in the desired percentage and load the roof one square at a time. This will provide even distribution. Additional care should be taken by the roofer laying the tiles to avoid clumping of a single color or range.

After the installation of about 75-100 tiles, the roof should be inspected from the ground at a distance greater than 40 feet to determine that there are no streaks or blotches. To ensure a good color blend, this inspection must be done at regular intervals.

***NOTE: It may be helpful to lay the tile blend out on the ground so the installer has a visual example. Make one person responsible for the ongoing and end result of the blending.***

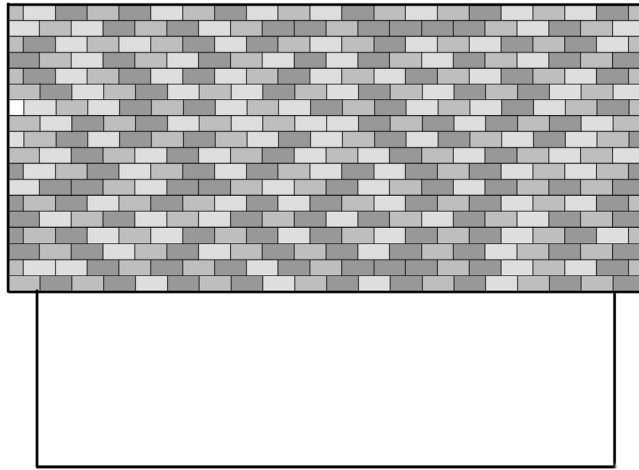

Figure 21.1 Properly Blended Tile

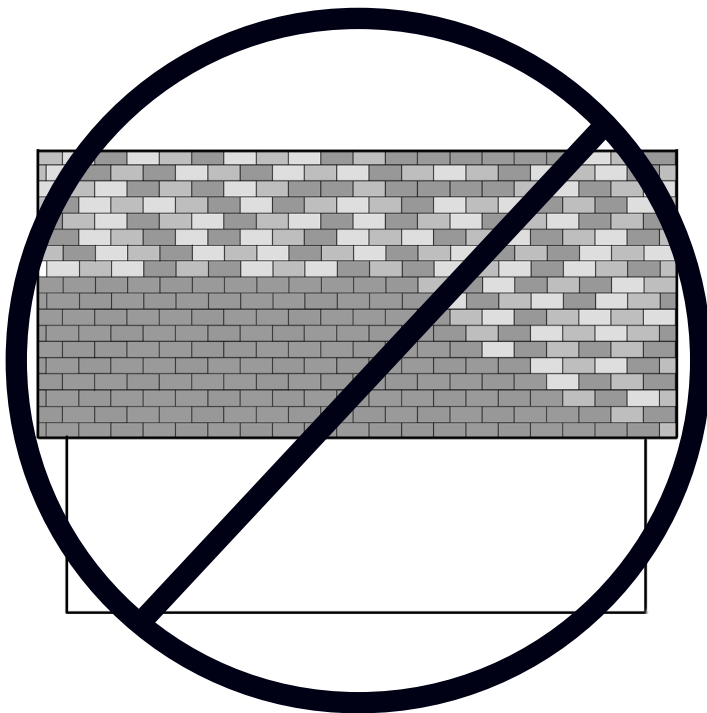

Figure 21.2 Improperly Blended Tile. There Should Be No Hotspots or Diagonal Patterns Visible.

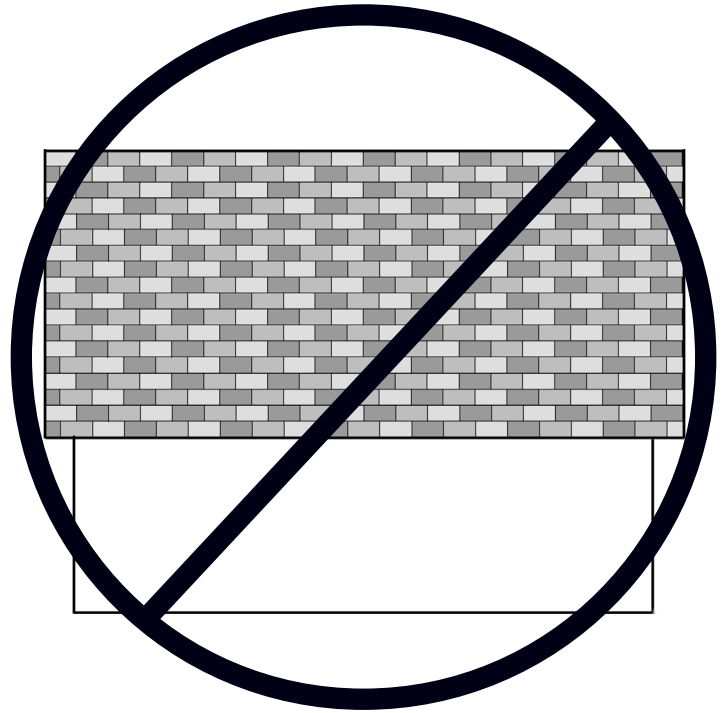

Figure 21.3 Improperly Blended Tile. Do Not Install the Tiles In a Repetitious Pattern.

# Installing the Flashing

**IMPORTANT:**

*Where roofs intersect other roofs, parapet walls, chimneys, ventilators, vent pipes and similar projections, flashings are required. There is a natural weakness at these intersections and properly installed flashings are required to make the intersection watertight. Expansion and Contraction due to temperature changes contribute to the weakness, so it is extremely important to correctly design and install the flashings and to use durable flashing material (a minimum of 16 oz. sheet copper is recommended).*

*General flashing details are shown in this section but many more exist for each particular situation which cannot be covered in the context of this tile installation manual. Proper flashing installations are critical for a watertight roof.*

## Eave Flashing

Where eave metal flashing is used, it should be formed using a minimum of 16 oz. sheet copper with a drip edge along the bottom to allow water to drip off the edge of the roof (See Figure 22.1).

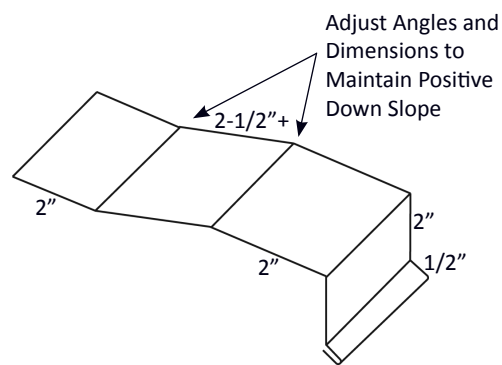

Figure 22.1 Eave Flashing Dimensions

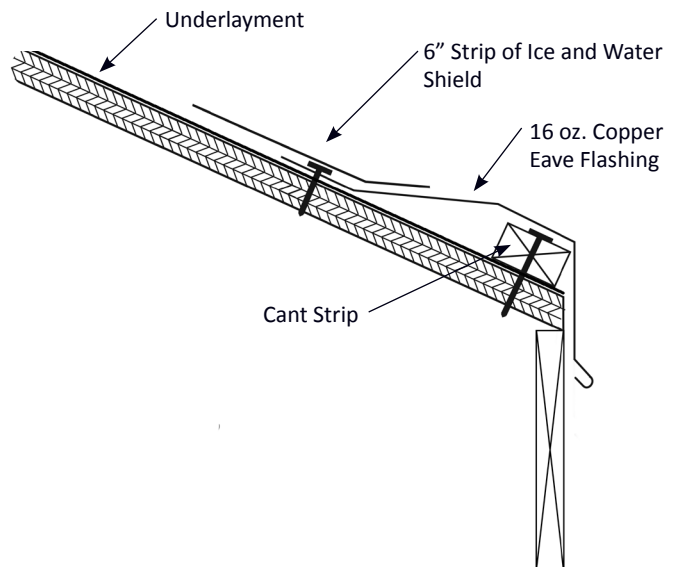

Figure 22.2 Copper Flashing Eave Detail

## Rake Edge Flashing

For rake flashing, 16 oz. or heavier copper flashing should be installed to serve as a drip edge and as a finished edge.

The gable flashing is to be installed over the waterproof underlayment. For an open rake design the flashing must extend 5" onto the deck and 2" down over the fascia with a 1/2" hemmed edge (see Figure 23.1). For a Closed Rake design the flashing should extend 5" across the roof deck with V diverter and a hem at the edge. At the edge of the roof deck, the flashing is to extend up (perpendicular to the deck) 2" and back down at least 5 1/2" along the gable fascia board with a 1/2" crimp at the bottom edge to serve as a drip edge. The gable flashing pieces are to lap each other to form an overlap of at least 4". If using attached gable rake tile no flashing is required.

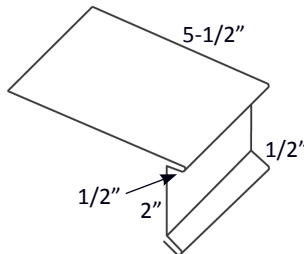

Figure 23.1 Open Rake Flashing Dimensions

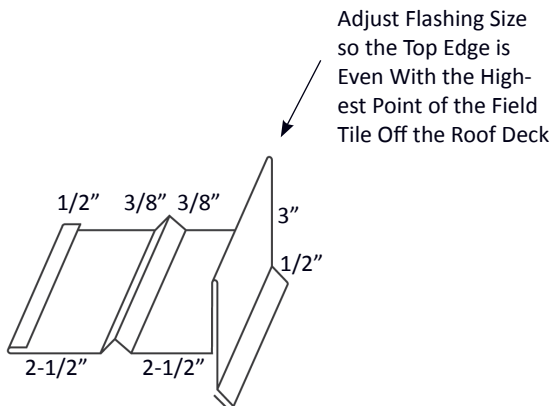

Figure 23.2 Closed Rake Flashing Dimensions

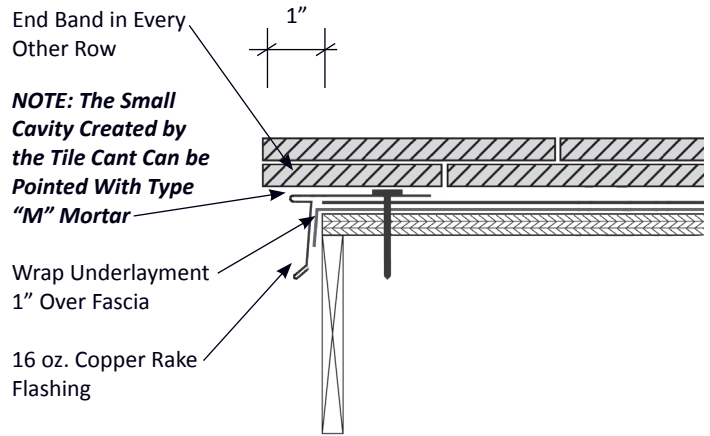

Figure 23.3 Open Rake Detail

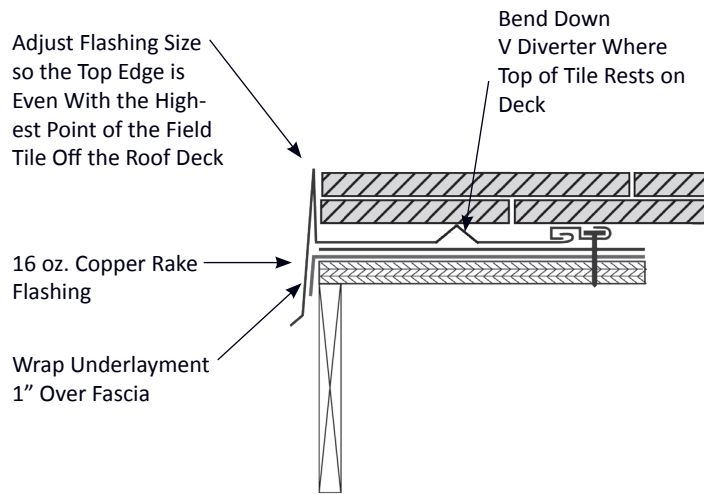

Figure 23.4 Closed Rake Detail

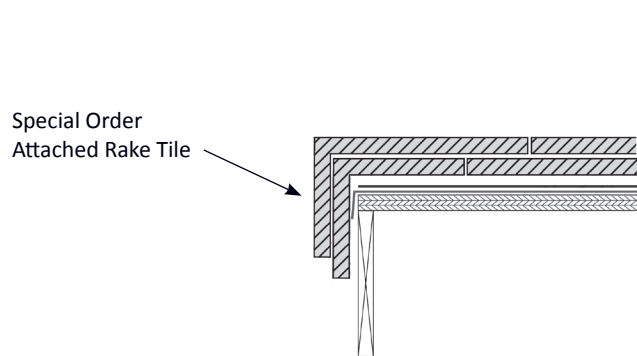

Figure 23.5 Attached Rake Detail

## Flashing at Valleys

Valleys, since they collect the water runoff from the portions of the roof sloping into them, are particularly prone to water migration and leakage. A clear and unobstructed pathway for quick water drainage is essential in valleys. There are two basic types of valleys in tile roof installation: open and closed valleys. Open valleys are the standard and preferred choice as they reduce debris collection and potential water infiltration.

### Open Valleys

In an open valley construction the tiles are held back from the center of the valley to expose the copper flashing. The advantage of an open valley is that it permits unobstructed drainage. Open valleys are recommended in areas with surrounding foliage where the leaves, needles and other debris can fall on the roof and potentially slow or block the runoff of water from the roof (see Figure 24.2).

The valley metal is to be secured with approved fasteners. At no time are nails to be placed in the area of the valley that will be carrying water.

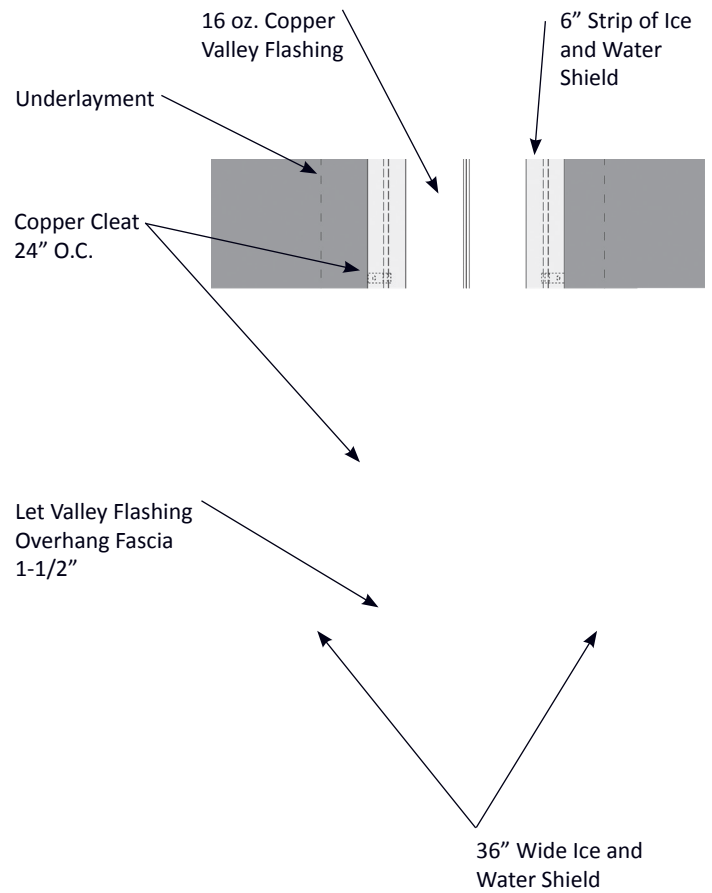

Figure 24.2 Open Valley Flashing Detail

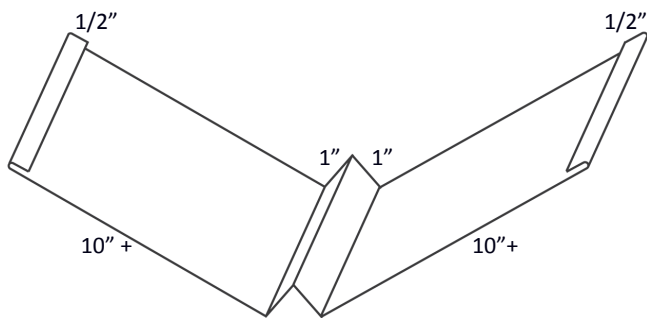

Figure 24.1 Valley Flashing Dimensions

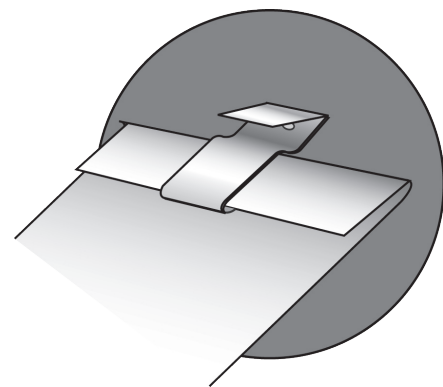

Figure 24.3 Copper Cleat Detail



### Closed Valleys

In a closed valley, the tiles from the adjoining roof are mitered and abutted. Since water migrates through a closed valley onto the sheet copper flashing which carries the runoff, this type of construction is considered decorative.

All closed valleys should be step flashed with a 16 oz. copper sheet, at least 24" wide with a 1/2" edge turned over and fastened with cleats. Joints should not be soldered.

**NOTE: Underlayment for all valleys must be a full width sheet (36") of two layers of No. 43# coated base sheet or a layer of self-adhesive modified bitumen membrane. Each course from the adjoining fields must overlap the valley underlayment by at least 12".**

**NOTE: Closed valleys should not be used where foliage debris can fall onto the roof, accumulate and cause water backup in the valley.**

**Closed valleys should not be used where the rafter length or pitch varies on adjacent roof planes. It is important that corresponding courses align coming into the valley.**

**Ludowici strongly discourages the use of closed valleys in areas with snow fall. Snow accumulation in a closed valley can cause ice dams, damaging the roof tile and creating potential leaks.**

Valley Flashing Pieces Should Extend 11-1/2" from Valley Center Line

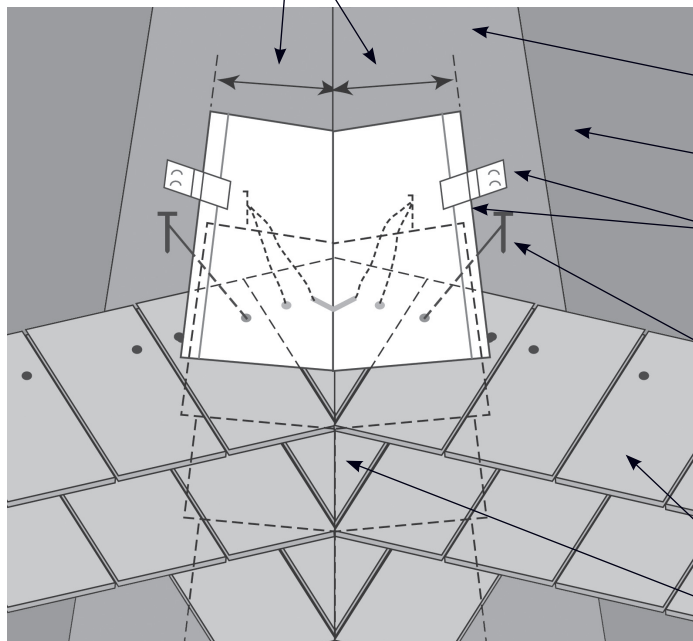

Figure 25.1 Closed Valley Detail with Step Flashing

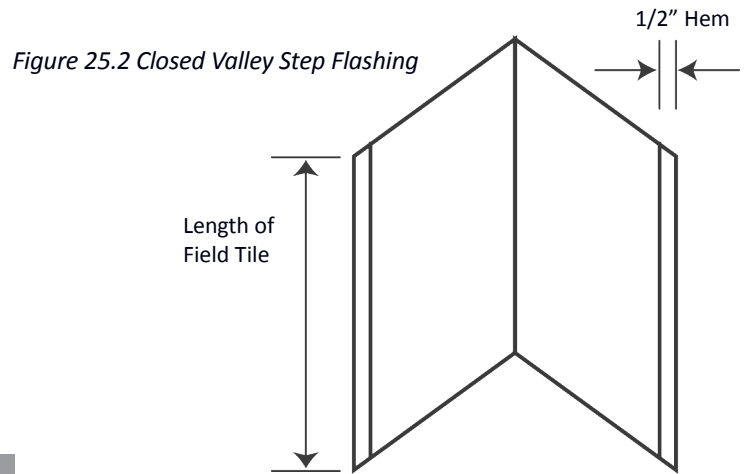

Figure 25.2 Closed Valley Step Flashing

- 36" Wide Ice and Water Shield
- Underlayment
- 16 oz. Copper Valley Step Flashing Attached With Copper Cleats
- Do Not Penetrate Copper Valley With Nails. For Valley Tiles, Place Nails Beyond Flashing Perimeter and Attach Valley Tiles With 16 ga. Copper Wire
- Shingle Field Tile
- Field Cut Valley Tiles, Cut to Maintain a Straight and True Line. Special Order Valley Tiles May be Ordered

## Flashing at Vertical Walls

The transition from roof to side wall is flashed with step flashing.

### Step Flashing

In the step method of flashing, individual 16 oz. sheet copper flashing is applied between each course of tile. A minimum head lap of 3" must be provided from step flashing to step flashing.

The following criteria should be used to determine the appropriate size for step flashing:

1. The step flashing should be the length of the field tile plus 1".
2. The step flashing should extend up the vertical surface a minimum of 4" and allow for a minimum of 2" overlap of the siding, cladding or copper counterflashing.
3. The step flashing should extend a minimum of 5" onto the roof so that there is at least a 5" overlap of the underlying tile.
4. The flashing should be at least 16 oz. sheet copper.

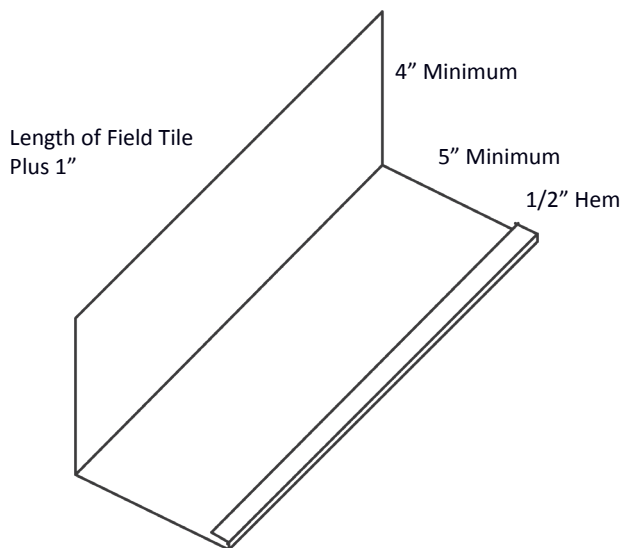

Figure 26.1 Side Wall Copper Step Flashing

16 oz. Copper Step Flashing  
Do Not Penetrate Step Flashing  
With Tile Fasteners

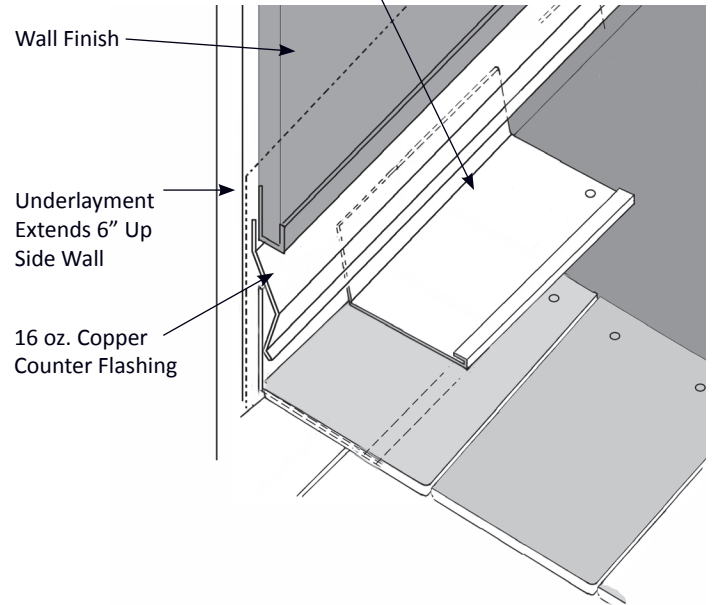

Figure 26.2 Side Wall Copper Step Flashing With Counter Flashing

16 oz. Copper Step Flashing  
Do Not Penetrate Step Flashing  
With Tile Fasteners

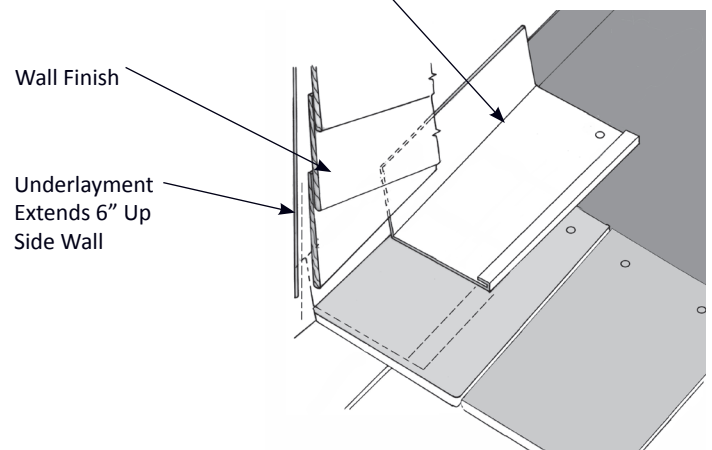

Figure 26.3 Side Wall Copper Step Flashing for Siding

## Flashing at Open Valley at Main Roof to Dormer Juncture

For flashing where an open valley occurs at the intersection of a dormer roof and the main roof, the following steps should be taken.

1. The main roof tiles should be installed to just above the lower end of the valley, where the valley and the main roof intersect. Along the roof and wall juncture, step or channel flashing must be used and the last tile in the course should fit closely against the wall of the dormer (see Figure 27.1).
2. The bottom end of the copper valley flashing should be cut so that it extends  $1/2$ " below the down-slope edge of the dormer roof deck at the bottom of the valley. This lower cut edge should project a minimum of 2" below the intersection of the dormer and main roof.

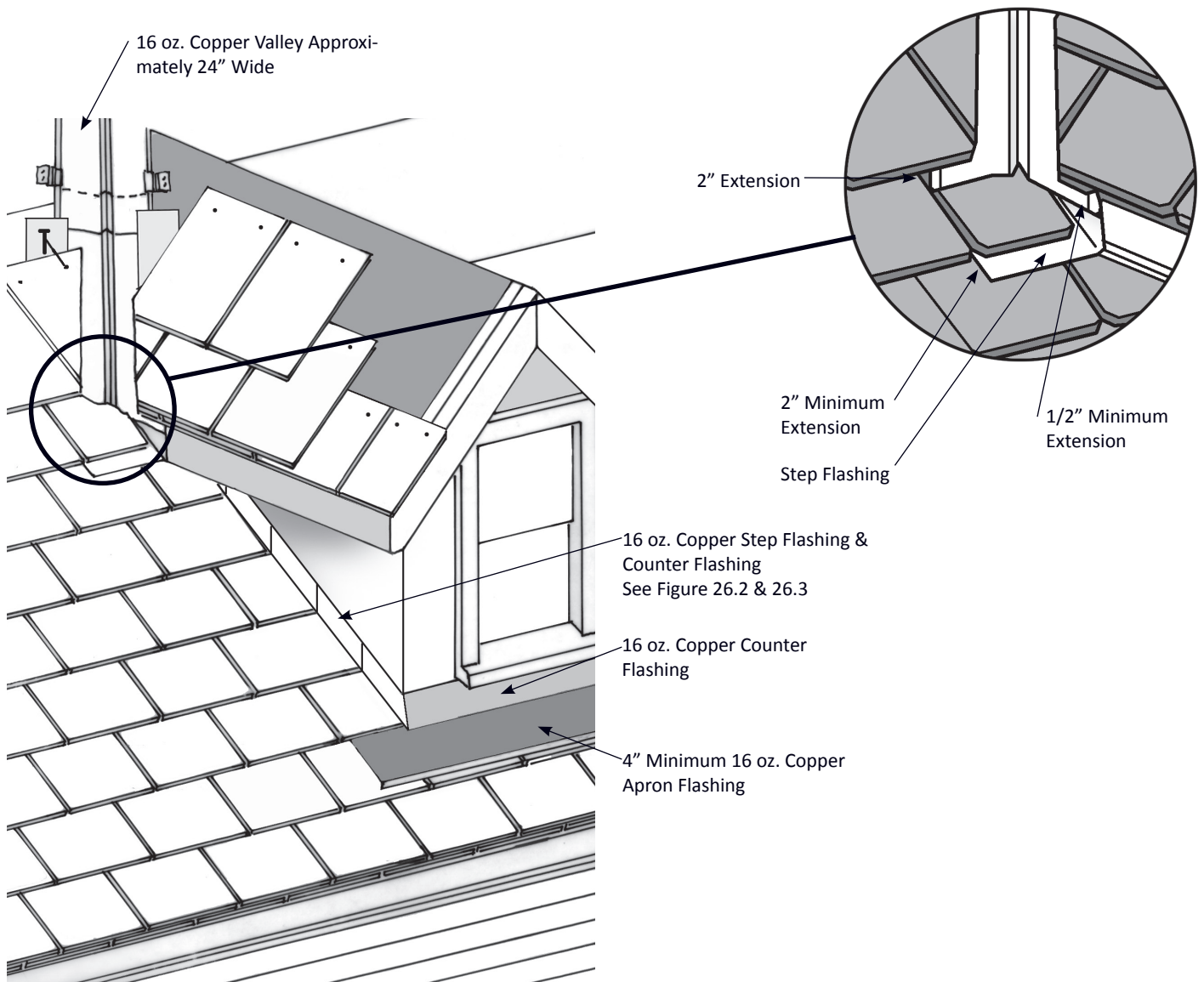

Figure 27.1 Open Valley at Main Roof to Dormer Juncture

## Flashing at Head Wall

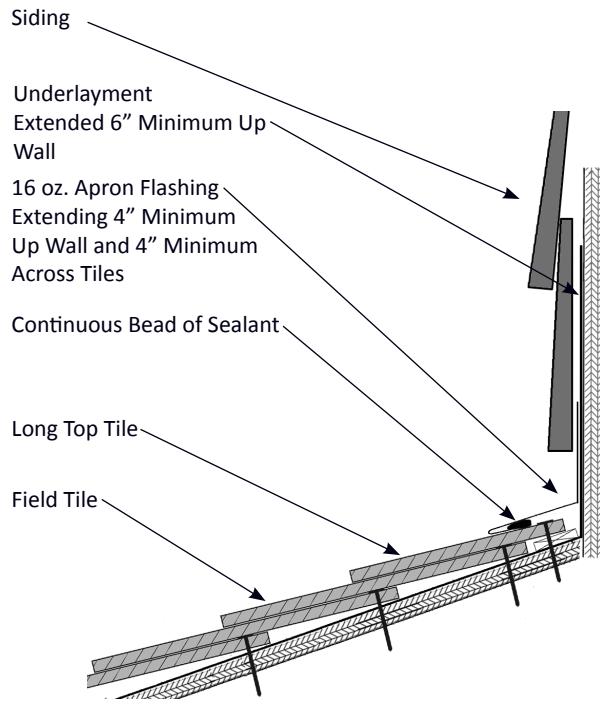

Figure 28.1 Apron Flashing at Head Wall Detail

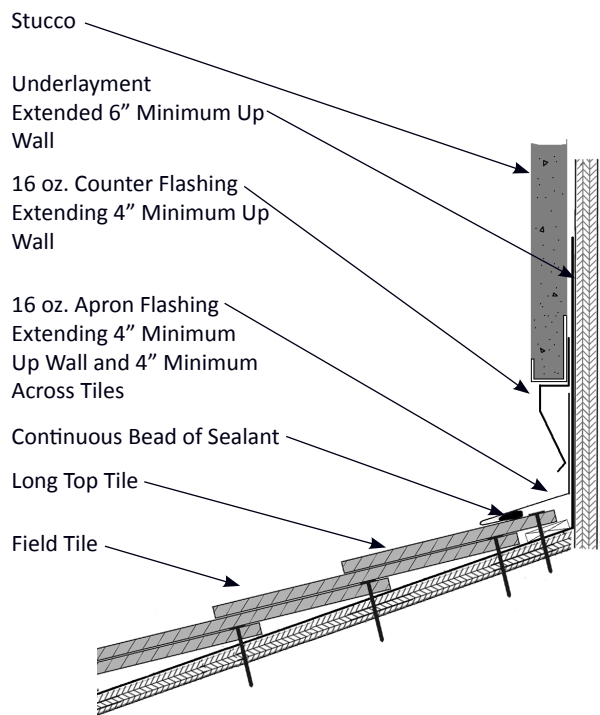

Figure 28.2 Counter Flashing & Apron Flashing at Head Wall

## Flashing at Chimney

Since the foundations of chimneys are usually structurally separate, the flashing around chimneys needs to be able to accommodate movement from differential settlement without compromising the watertightness of the roof. Regardless of the climate, install self-adhering Ice and Water Shield membrane around the base of the chimney before the underlayment is applied as a protection against ice dams. Four types of flashing are required to properly flash around chimneys.

1. Apron flashing at the down slope face over the installed tiles – 4" minimum exposed width, 6" up the face of the chimney and continuously counterflashed.
2. Step flashing along the sides of the chimney.
3. Cricket or backer flashing on the upslope side or back.
4. Continuous counterflashing embedded in masonry joints.

### Counterflashing

Sheet copper counterflashing should be installed to overlap all vertical flashing flanges extended up the sides of chimneys. This is best accomplished by the mason during construction.

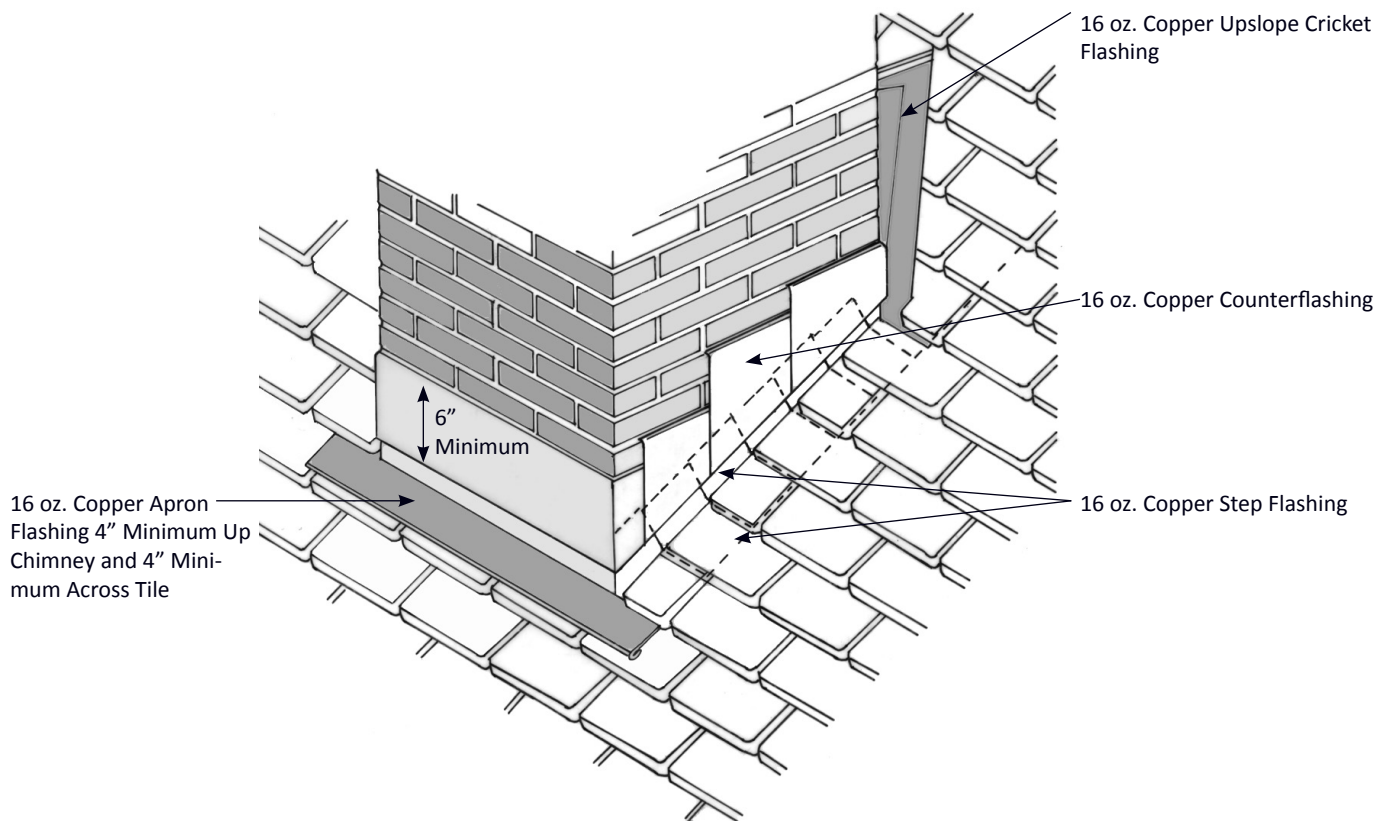

Figure 29.1 Chimney Flashing

## Additional Flashing Details

Plumbing pipe vents and stacks, skylights, roof-to-roof transition and other penetrations all require special flashing.

**NOTE: Be sure to order skylights with a flashing package specifically designed for tile roofs and to accommodate the combined thickness of the layers of Shingle tile specified.**

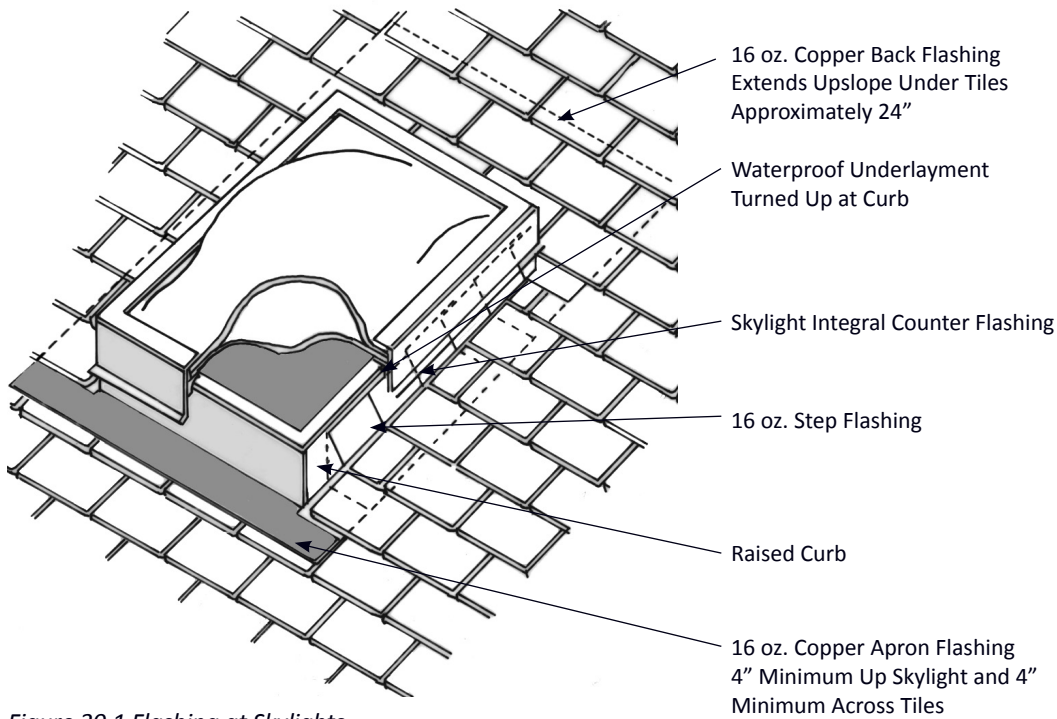

Figure 30.1 Flashing at Skylights

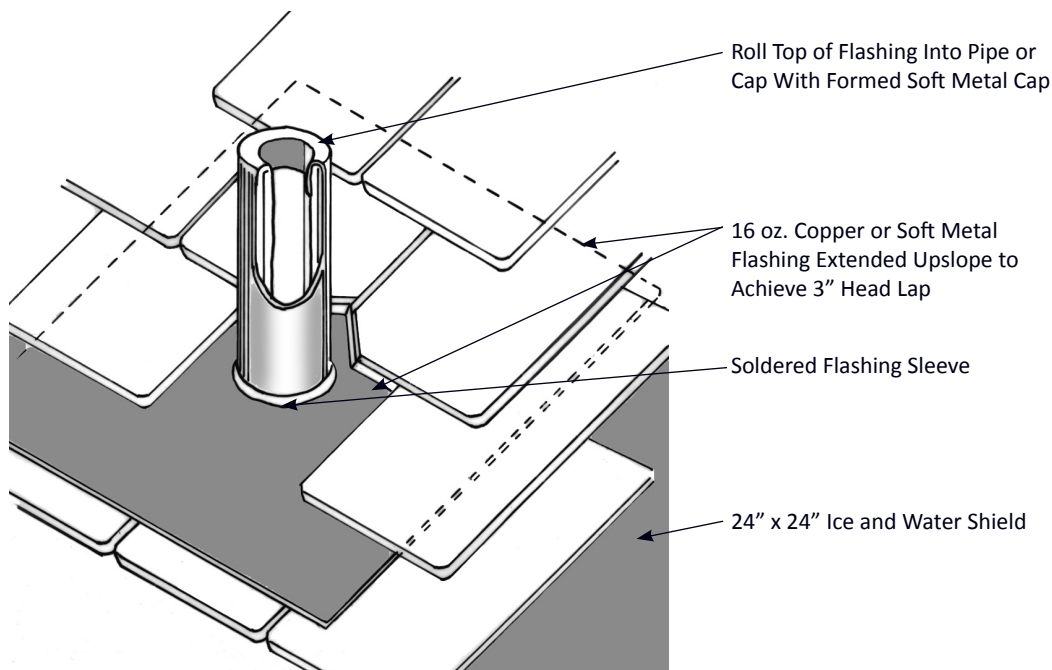

Figure 30.2 Flashing at Vents

## Flashing at Pitch Change

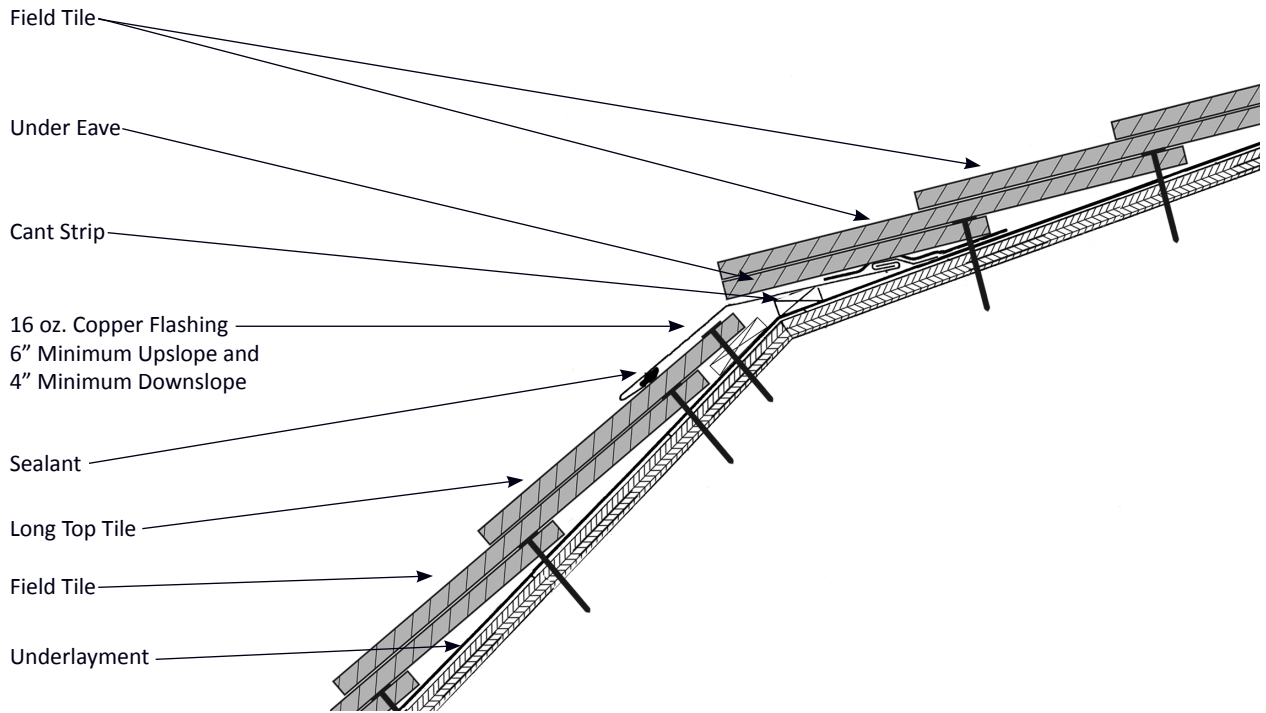

Figure 31.1 Flashing at High Slope to Low Slope Transition

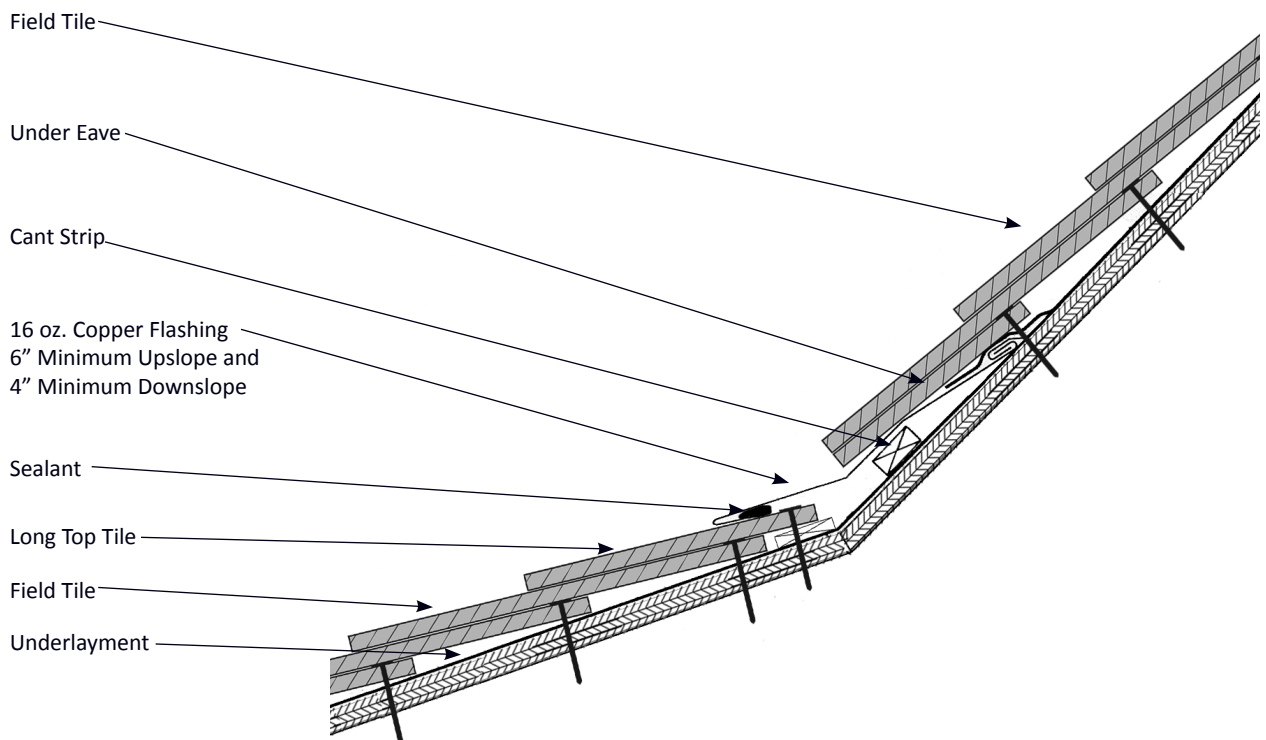
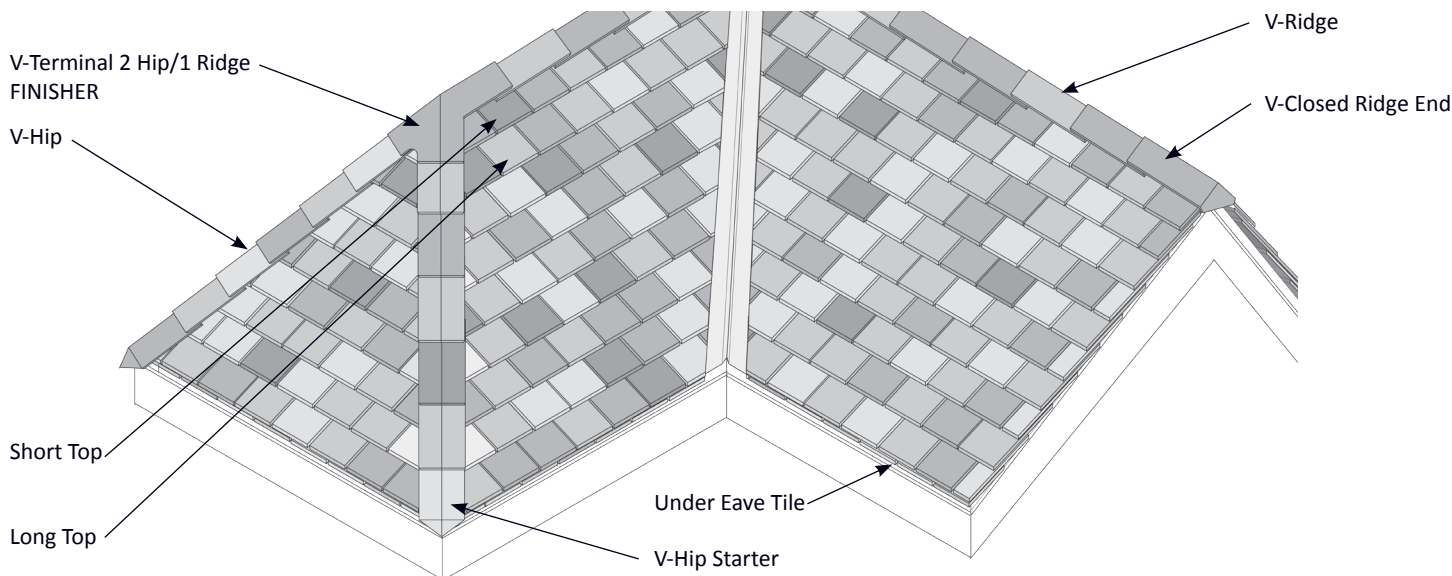

Figure 31.2 Flashing at Low Slope to High Slope Transition

# Flat Shingle Tile Installation

Figure 32.1 Shingle Tile



The following roof preparations must be completed before installing any roof tile.

For detailed information on these items refer to the previous sections in this manual or the NRCA Manual on Steep Roofing.

- Install the flashings required for ensuring watertightness:
  - Eave Flashing
  - Rake Edge Flashing
  - Valley Flashing
  - Dormer and Sidewall Flashing, Skylight Flashing, Chimney and Cricket Flashing
  - Vent Flashing
- Underlayment for the entire roof deck, including the appropriate waterproof underlayments required for all flashing and, where required, the ice dam membrane
- All cant strips and Hip and Ridge stringers should be installed and covered in underlayment.
- Roof surface chalked with vertical and horizontal lines
- **To avoid damaging the new roof adjoining walls, chimneys and other above the roof line components of the structure should be complete prior to installing the tile to minimize other trades traversing the completed roof.**

## Points to Remember During Field Tile Installation

Tile installation will generally progress in a diagonal fashion, moving from the starting point of the under eave tile.

- Use the chalk lines as a guide.
- Watch for any irregularities in the roof deck construction.
- After the installation of about 75-100 tiles, the roof should be inspected from the ground at a distance greater than 40 feet to determine that there are no streaks or blotches. To ensure a good range of tones, this inspection must be done at regular intervals.
- When each course is 10 to 12 tiles from the terminating end, compare the remaining distance to the width of the tiles to determine if a slight crowding or stretching of the tile may be required to ensure the last piece in the course is an end band (1/2 tile) or a full tile. DO NOT crowd or pull to the extreme any more than 5 or 6 pieces positioned side by side.



## Under Eave Tile

Installation of all the Ludowici flat Shingle tile patterns requires an Under Eave Tile. The under eave tiles are normally laid right to left or laid from the gable end to a valley. Normal practice requires the under eave tile to be laid with a 2" overhang at the eave and a 1" overhang at the rake. Lay the under eave course loose across the slope of the cant strip to determine what adjustments, if any, are needed in the course before nails or screws are installed. Once layout is established, install the under eave tile in the normal right to left fashion.

**NOTE: Each Shingle field tile is provided with (2) two fastening nail holes. When installing field tiles or accessories care should be taken to fasten each tile with nails or screws in every provided fastening hole.**

The second course should be laid to provide the proper exposure, creating the 2" triple thickness area (see Figure 33.1). See Valley Tiles, Page 34, for information on installing tiles of roof decks which include valleys.

## First and Succeeding Courses of Tile

Flat Shingle clay tile are laid out from right to left, in double thickness. The starter course begins with an end band (half tile) placed directly over the first under eave tile. All joints of the starter course and succeeding courses should be centered over the previous course or at least 3" from any other underlying vertical joint.

**NOTE: End bands shall be fastened typical of standard field tile, but also requires roofing cement (meeting requirements of ASTM D-4586) applied between the head laps.**

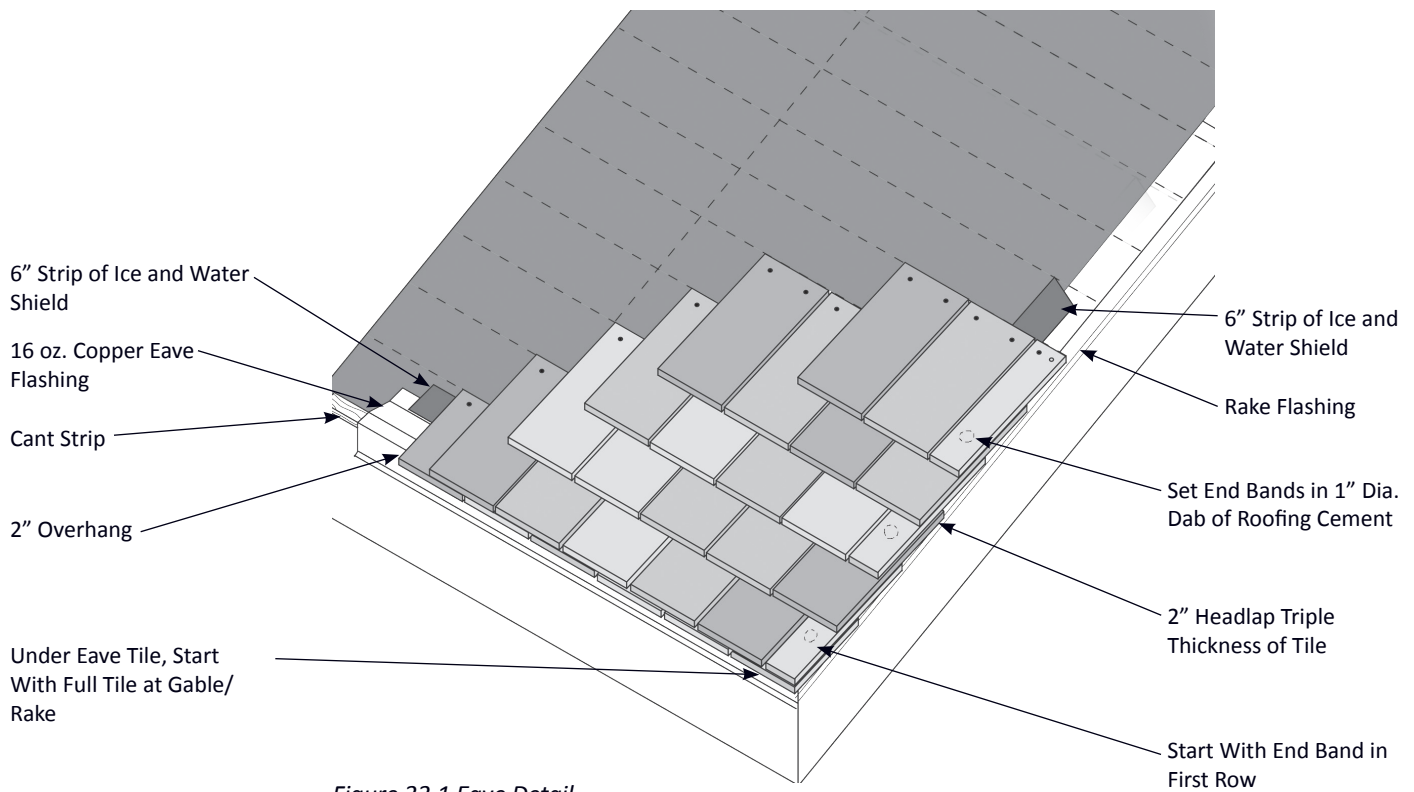

Figure 33.1 Eave Detail

## Valley Tiles

Tile to be installed in valleys can be mitered in the field or by ordering and using special factory tile. Whether field miter cut or factory tile are used, the tile fasteners should never penetrate the valley flashings. Tile to be installed over the copper valley flashing should be drilled or notched and wired with solid 16 gauge wire to fasteners driven into the deck beyond the flashing.

**NOTE: Notching and drilling was addressed previously on Page 19. In situations where valley tile pieces are so small that it is not practical to notch or drill, use the adhesive RT600 (an OSI product) or its equivalent.**

If special factory valley tile are being applied prior to installation, it will be beneficial to loose lay the entire eave field tile course including the valley tile. This loose laying process of the valley's left side will advance as a typical installation would, from right to left. But, when loose laying the valley's right side, it will advance from left to right. With the installation of Shingle tile, this should not create any concerns. Start by loose laying the valley tile to the already chalked valley line and continue away from the valley with the first course of tile. Once layout is established, install the tiles in the normal right to left fashion.

The loose laying process becomes vitally important when the roof deck runs from valley-to-valley. The focus must be to space the eave course so it consists of all full field tiles and is finished on both ends with the special cut valley tiles or so it consists of all full field tiles, one end band (half tile) and is finished, as stated above, with the special cut valley tiles. Keep in mind not to allow any more than 1/4" side gap between two tiles and not to crowd any more than 5 pieces together. When the distance between valleys is so minimal that it does not allow for the above

mentioned spacing, one field tile per course will require field cutting to allow for proper lay up.

If field mitered valley tile are applied, they should be trimmed to provide a clean, even, continuous edge along the entire valley length.

**To encourage leaves and snow to slide down the valley, the gap between the Valley Tiles and the center line of the valley should be tapered from 3" at the top to 4" at the bottom, this can be increased for longer valleys.**

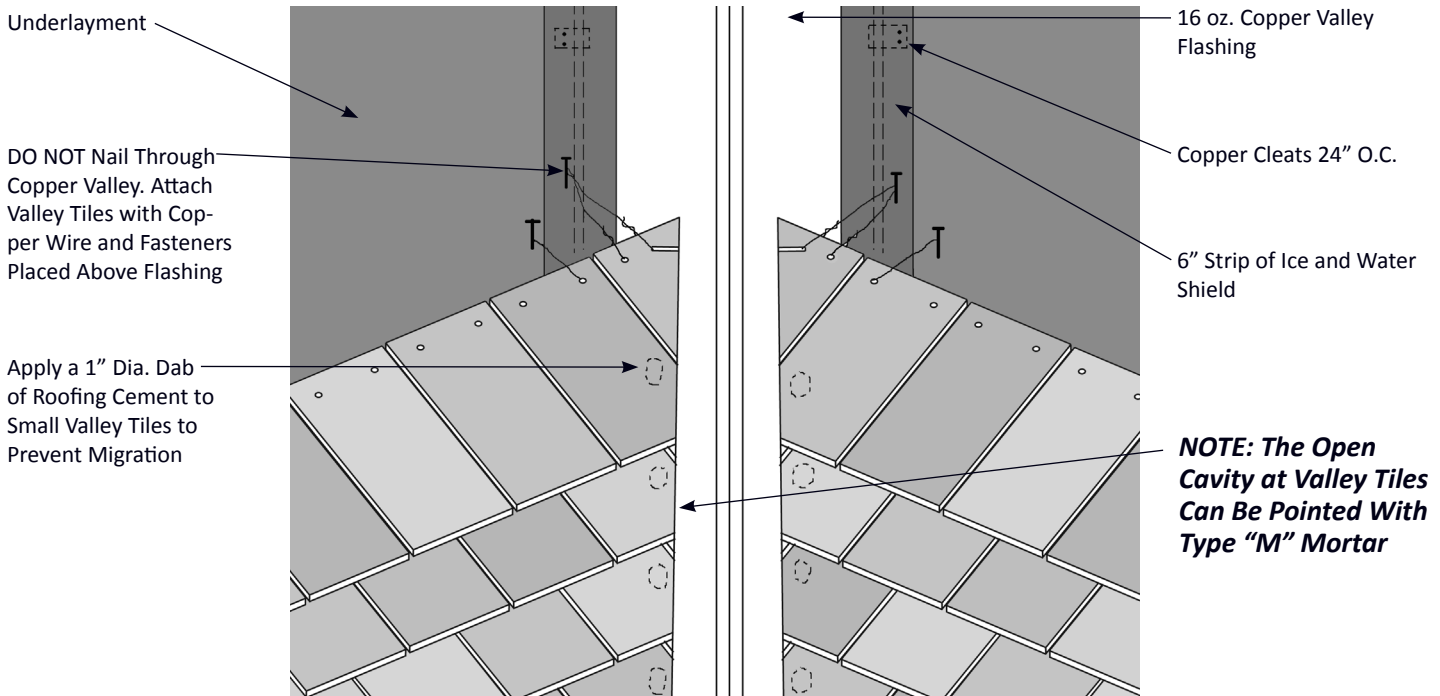

Figure 34.1 Valley Detail

## Hip Tiles

There are a number of methods to finish the hips of a flat Shingle tile roof depending on the design aesthetics desired. These methods are flushed mitered, Saddle Hip, Bonnet Hip, Sprocket Hip, V-Hip tile or one of Ludowici's other trim groups.

Tiles to be installed at hips are mitered in the field.

### V-Hip and Other Cap Type Hip Rolls

Hips are started with a special V-Hip Starter tile which should cover the field tile approximately 3" on both sides. The regular V-Hip tile is then installed by creating an approximate 2" head lap on the V-Hip starter tile. This 2" head lap is continued up the hip and roofing cement or sealant is applied at each hip tile's overlap. The last fastener on the upslope end of the hip is typically covered with a V-Hip and Ridge Terminal. Some roof termination may require a combination of typical flashing details or a special tile piece. Consult the local Ludowici sales representative for the project's special roof requirements.

Roof Pitch Rise:Run	V-Hip	118 Hip
4:12	2 1/4"	2 7/8"
5:12	2 1/4"	2 7/8"
6:12	2"	2 7/8"
7:12	2"	2 3/4"
8:12	1 3/4"	2 3/4"
9:12	1 3/4"	2 3/4"
10:12	1 1/2"	2 5/8"
11:12	1 1/2"	2 5/8"
12:12	1 1/4"	2 5/8"
13:12	1 1/4"	2 5/8"
14:12	1 1/4"	2 5/8"

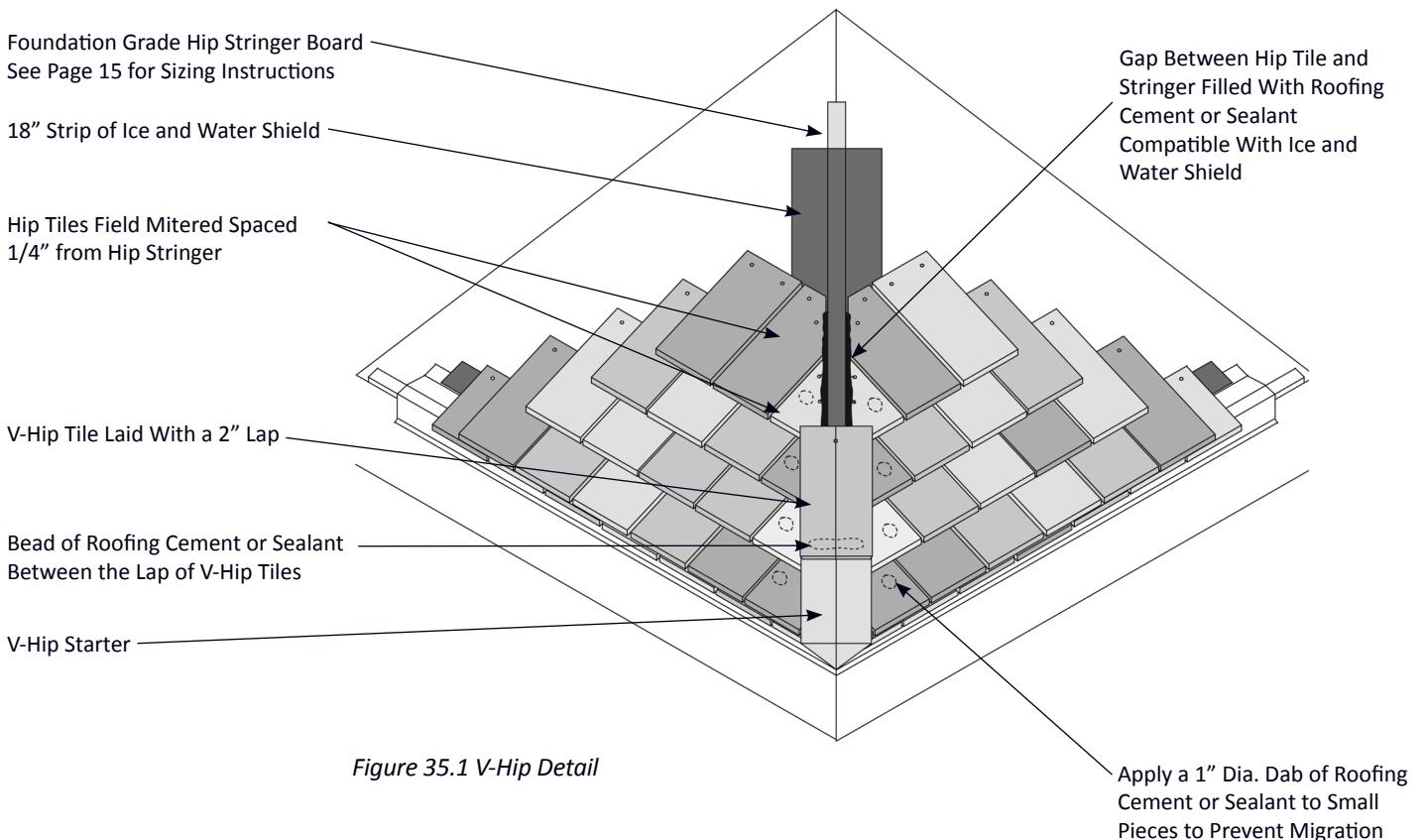
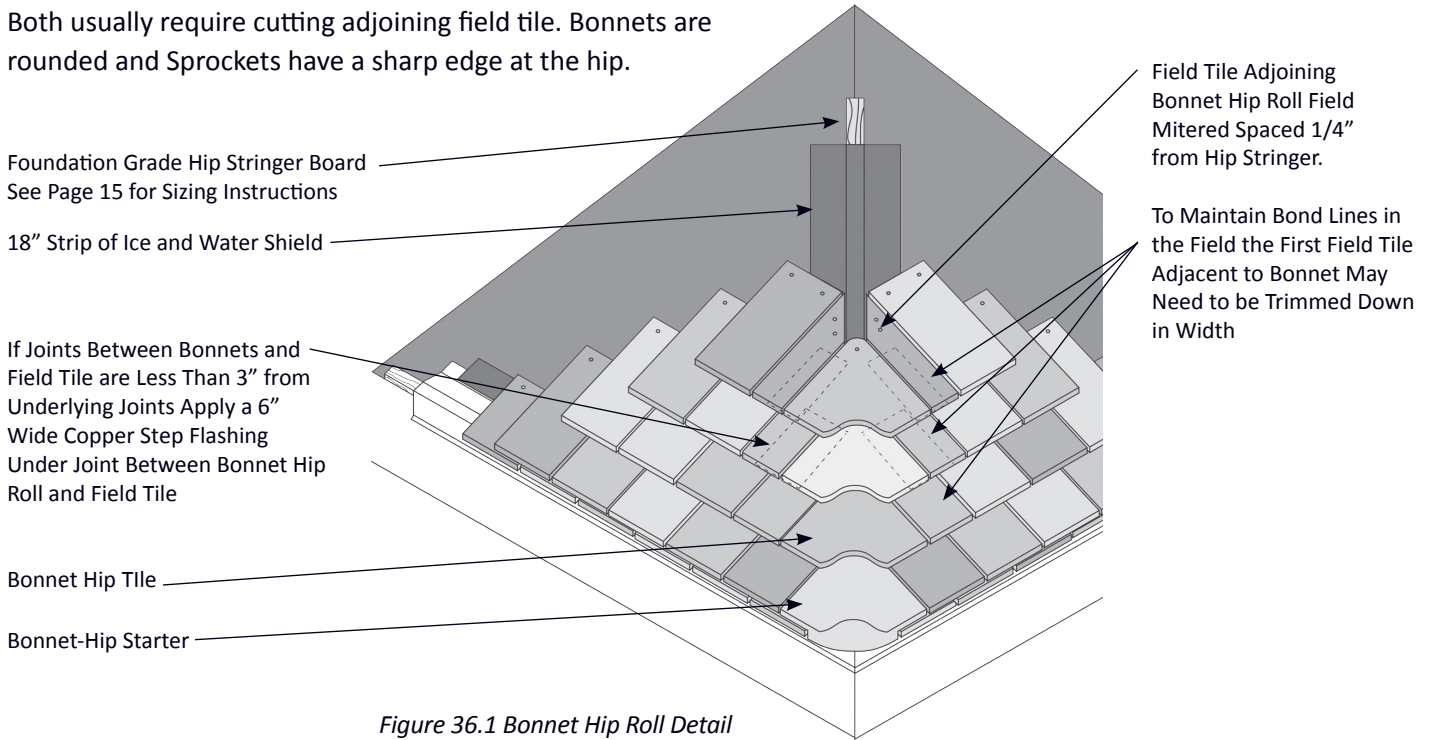

Figure 35.1 V-Hip Detail

**Bonnet Hip Roll or Sprocket Hip Roll**

Both Bonnet and Sprocket Hip rolls fit into the field of the tiles and wrap around the hip in a more seamless look. Both usually require cutting adjoining field tile. Bonnets are rounded and Sprockets have a sharp edge at the hip.



**Mitered Hip**

A flush mitered hip can be done by accurately miter-cutting the field tile and sealing the finished joint with an approved sealant meeting the requirements of ASTM D-4586. Mitered hips require the use of copper step flashing on every course.

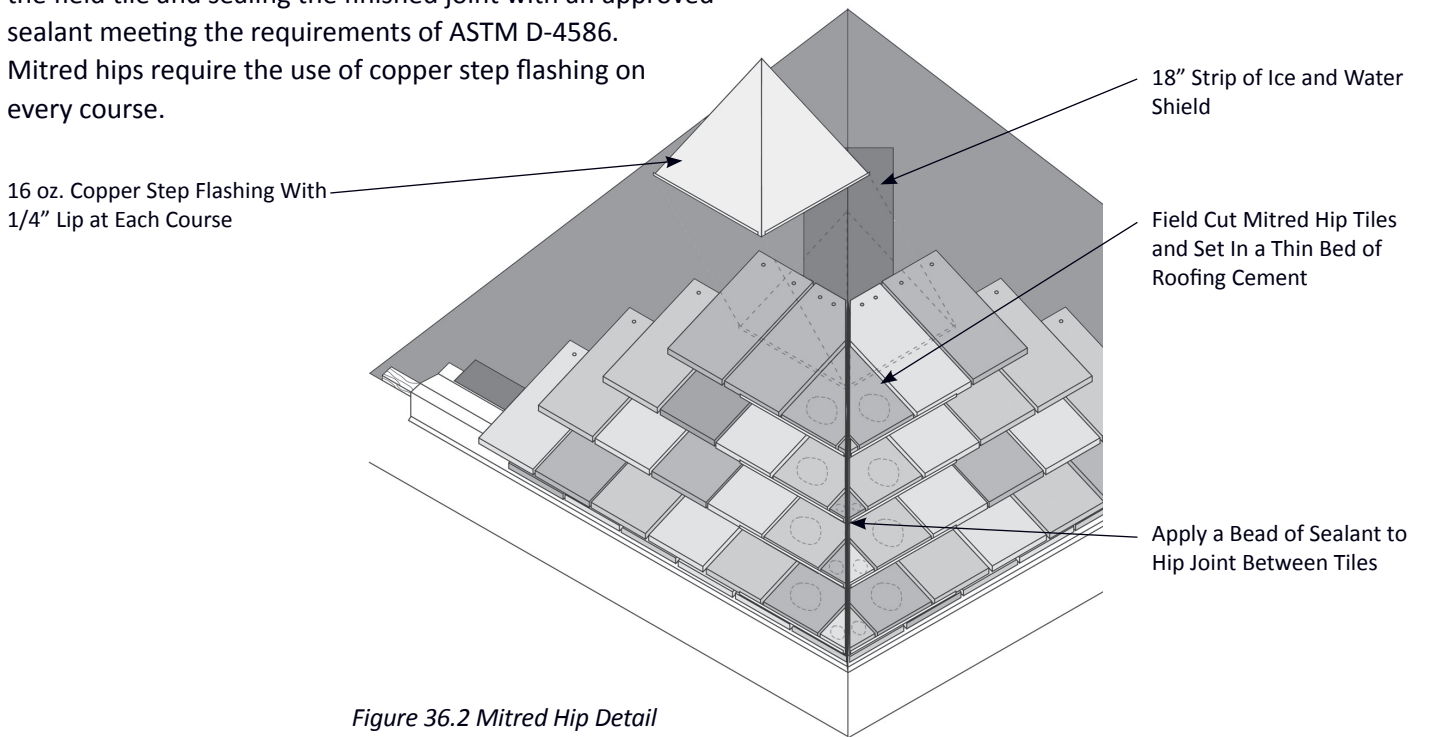

### Saddle Hip

Header Course tile is used to form a Saddle Hip and is sealed with an approved sealant meeting the requirements of ASTM D-4586 and is installed as shown in Figure 37.1. Saddle hips require the use of copper step flashing.

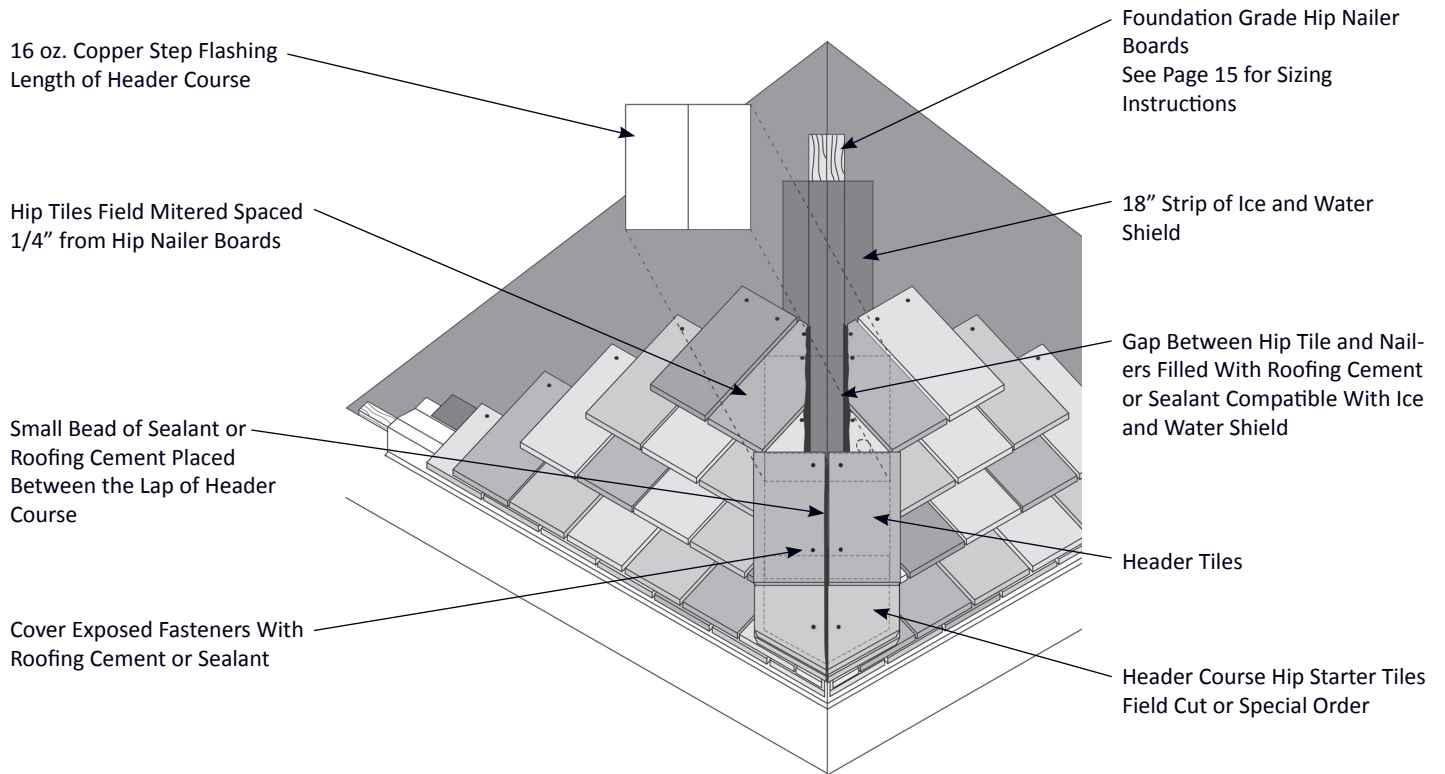

Figure 37.1 Saddle Hip Detail

The Ridge Angles and Hip/Ridge Terminal, for Both Mitered Hip or Saddle Hip, Shall be Mitered in the Field for Proper Fit, Nailed or Wired and Set in Roofing Cement Meeting the Requirements of ASTM D-4586.

Cover Exposed Fasteners With Roofing Cement or Sealant

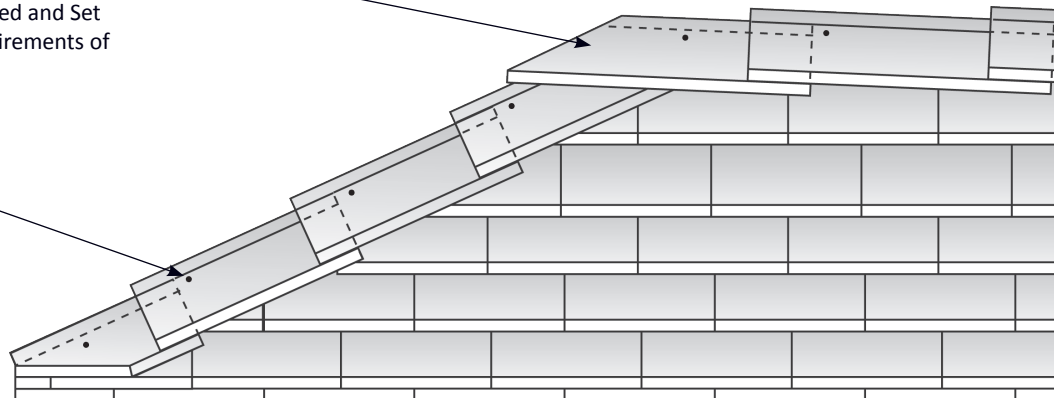

Figure 37.2 Saddle Hip & Saddle Ridge Terminal

# Ridge

## V-Ridge

The use of Ludowici's V-Ridge with the Shingle tile pattern requires the use of Long Tops and Short Tops. See Figure 38.1 for sequence of installation.

Roof Pitch Rise:Run	V-Ridge
4:12	1 1/4"
5:12	1"
6:12	13/16"
7:12	9/16"
8:12	3/8"
9:12	1/4"
10:12	3/16"
11:12	9/16"
12:12	7/16"
13:12	1/4"
14:12	1/8"

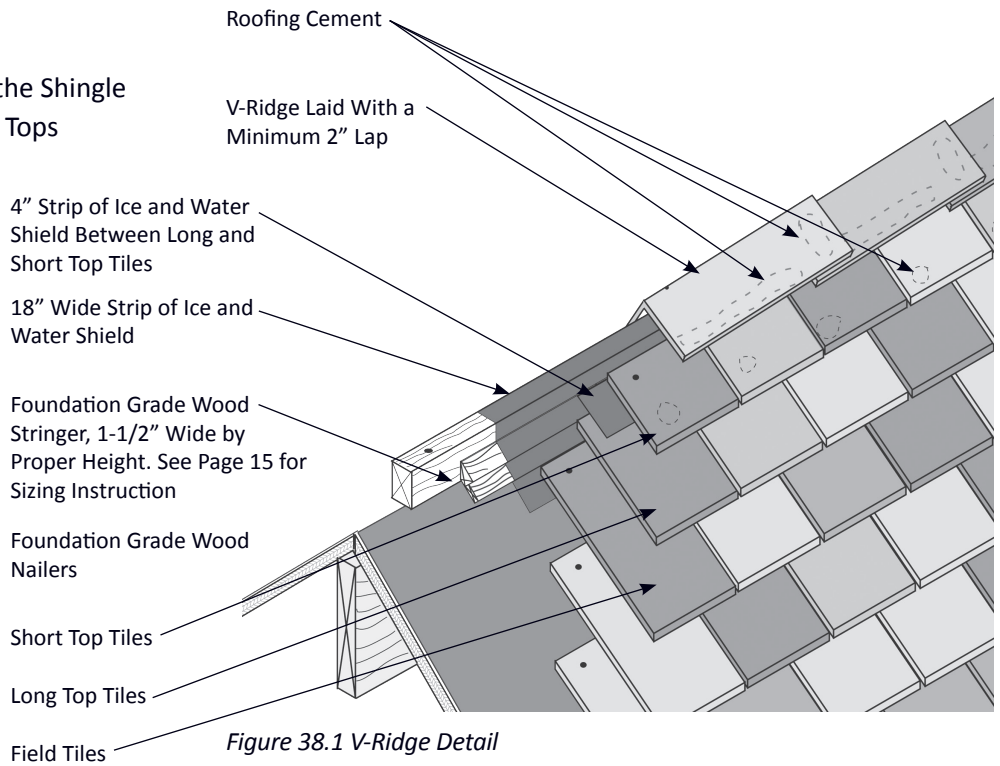

## Saddle Ridge

A saddle ridge uses Long Top tiles with Header Course tiles. Roofing cement must be applied where the header course tiles overlay each other and where they rest on the long tops. The ridge angles and hip and ridge terminal shall be mitered in the field for proper fit, nailed or wired and set in flashing cement meeting the requirements of ASTM D-4586.

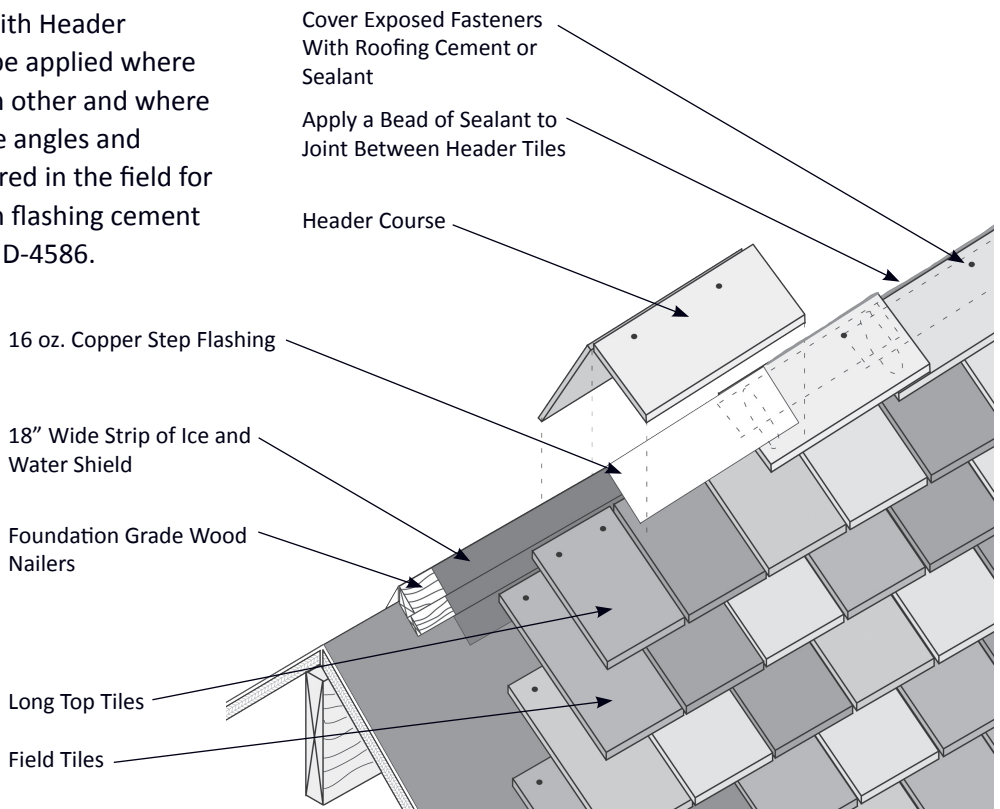

### Old Style Header Course Ridge

Old Style Header Course ridge uses Header tiles butted together over Long Top tiles. Header tiles are butted together and set in Type M mortar over continuous Copper flashing over Long Tops. The ridge angles and hip and ridge terminal shall be mitered in the field for proper fit, nailed or wired and set in flashing cement meeting the requirements of ASTM D-4586.

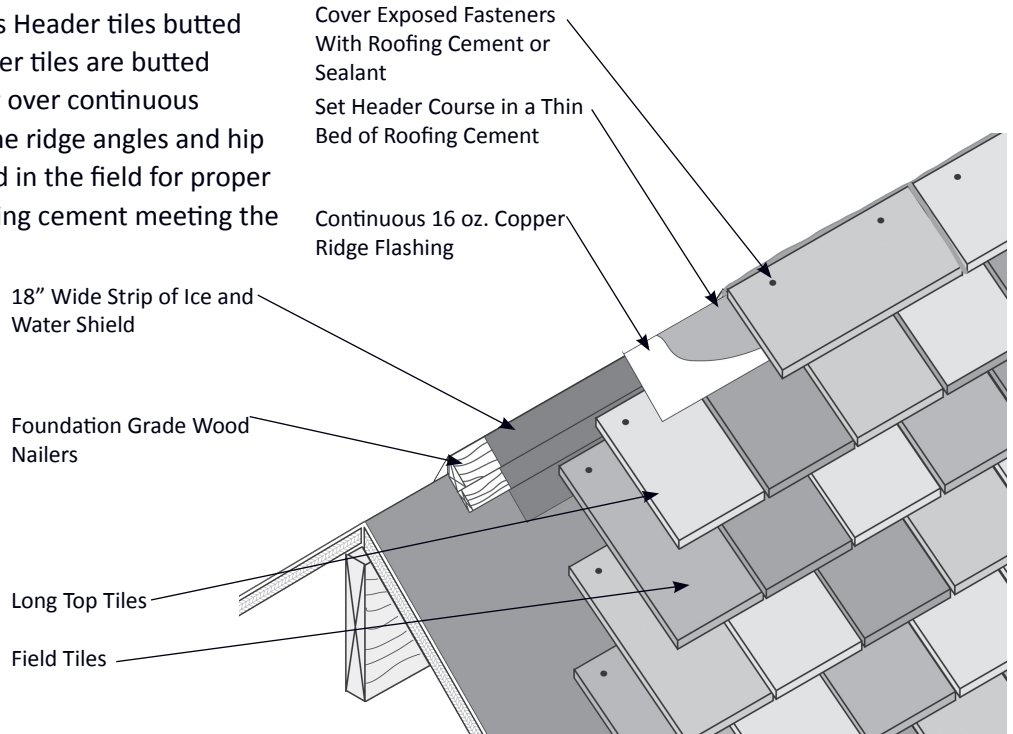

Figure 39.1 Flush Butted Header Course Ridge Detail

### Circular Cover Ridge Vented

Vented Circular Cover ridge requires the use of Long and Short Top tiles. **This Ridge Vent allows 5 square inches of ventilation per foot of ridge.**

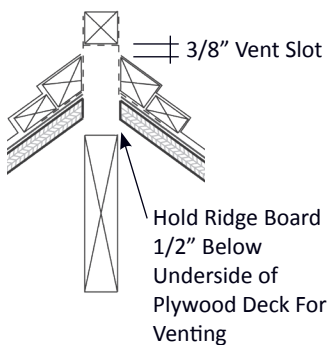

Figure 39.3 Vented Circular Cover Framing

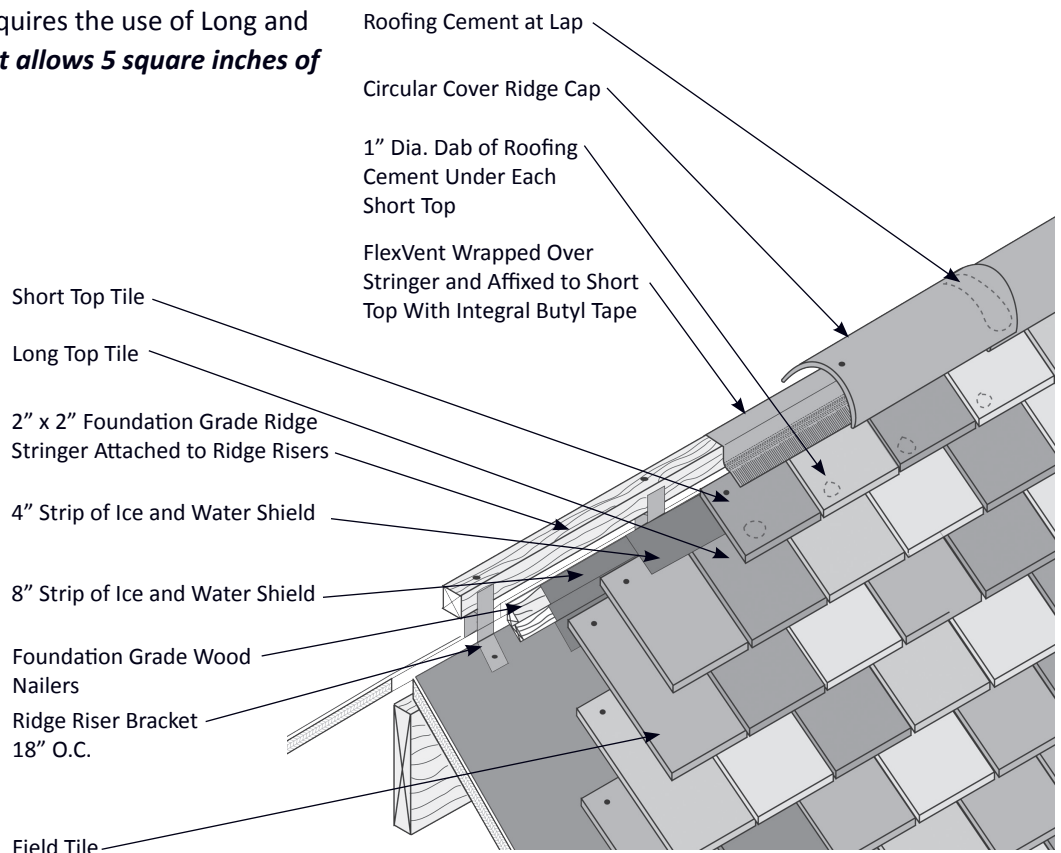

Figure 39.2 Vented Circular Cover Ridge Detail

**211 Ridge Vented**

Vented #211 Ridge tiles require the use of Long Top and Short Top tiles. **This ridge vent allows 6.27 square inches of ventilation per foot of ridge.**

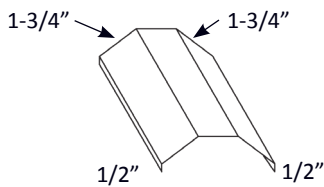

Figure 40.1 #211 Vented Ridge Cap Flashing

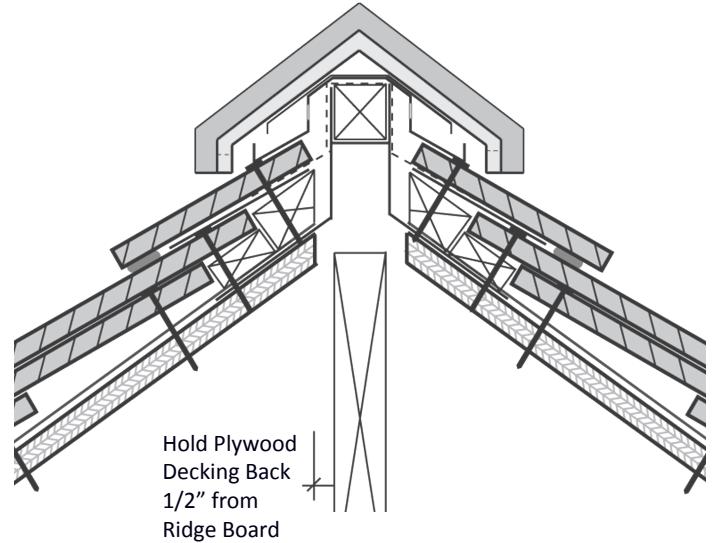

Figure 40.3 #211 Vented Ridge Section

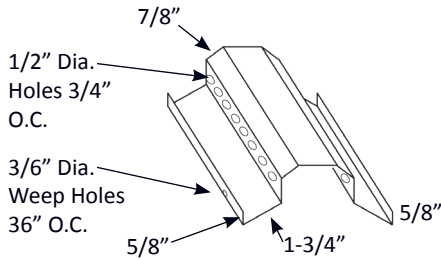

Figure 40.2 #211 Vented Ridge Vent Flashing

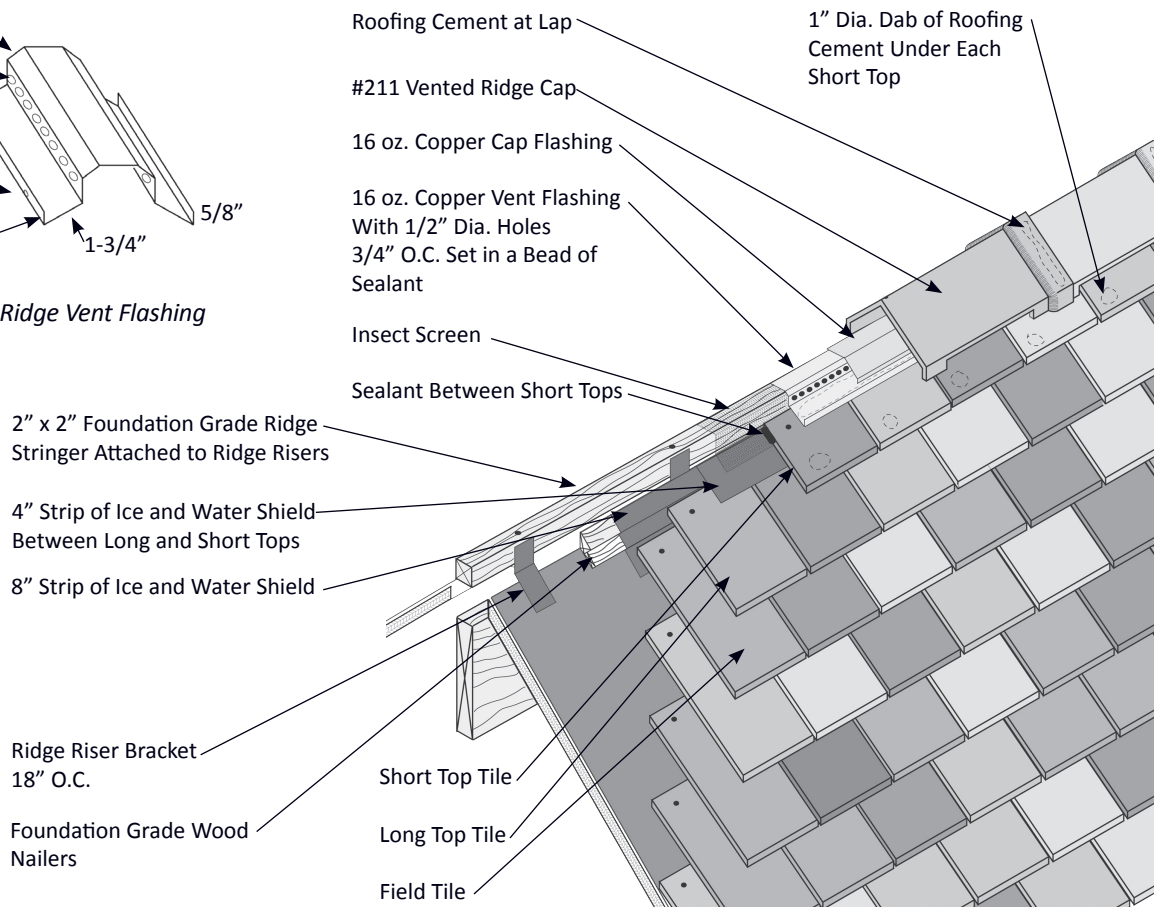

Figure 40.4 #211 Vented Ridge Detail



**Terminals**

Ludowici makes ridge end caps for all trim groups. Ridge end caps come as a starter or finisher, (a male/female lap). Care should be taken to determine correct orientation of the parts ordered and the proper installation sequence to accommodate the installation with minimal cutting.

Ludowici manufacturers Terminals to accommodate Ridge and Hip transitions. These are the most effective way to waterproof the transition and finish it in an aesthetically pleasing manner. Terminals are also made with a starter and finisher.

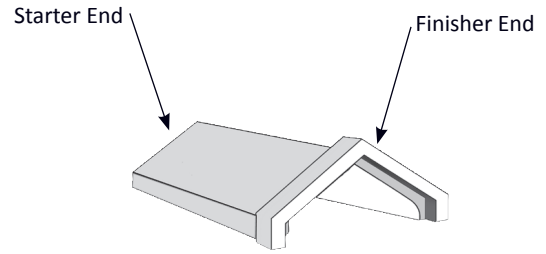

Figure 41.2 #211 Ridge Starter Finisher Diagram

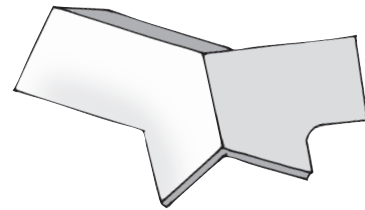

Figure 41.3 Typical 2 Hip/1 Ridge V-Terminal

**Vertical Wall Application**

Flat Shingle tile can also be used on a vertical surface. Short tops and long tops and under eave cant strips are used.

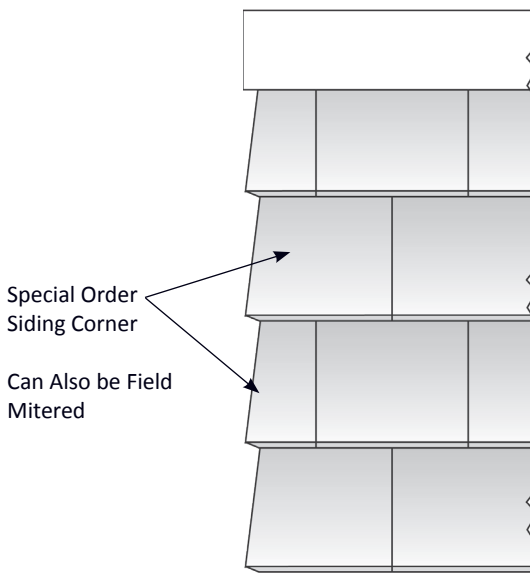

Figure 41.1 Vertical Wall Corner

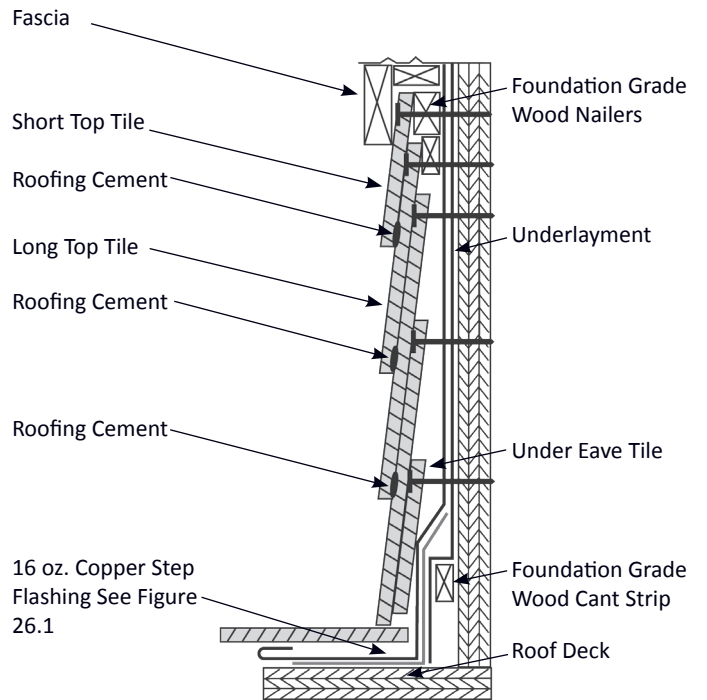

Figure 41.4 Vertical Wall Section

## Layout

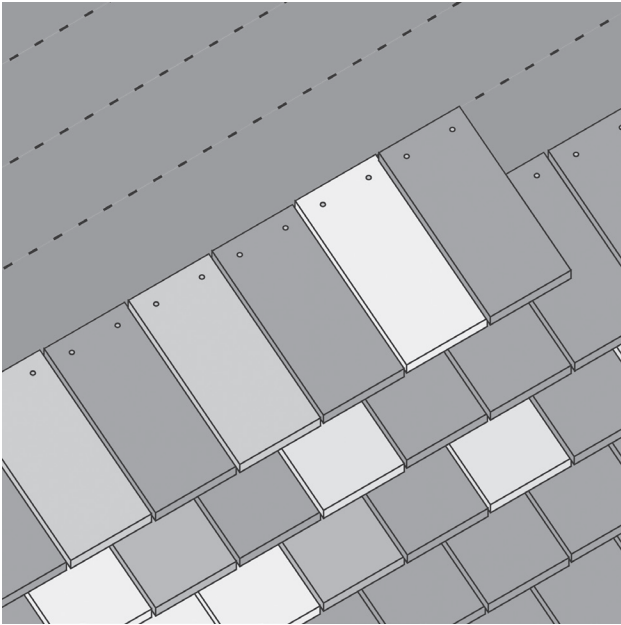

Figure 42.1 Formal Shingle Tile

Formal Shingle tiles are uniform in length and are typically installed in straight rows. **NOTE: Ludowici tiles are fired at over 2,000° and will have some slight shrinkage variations.**

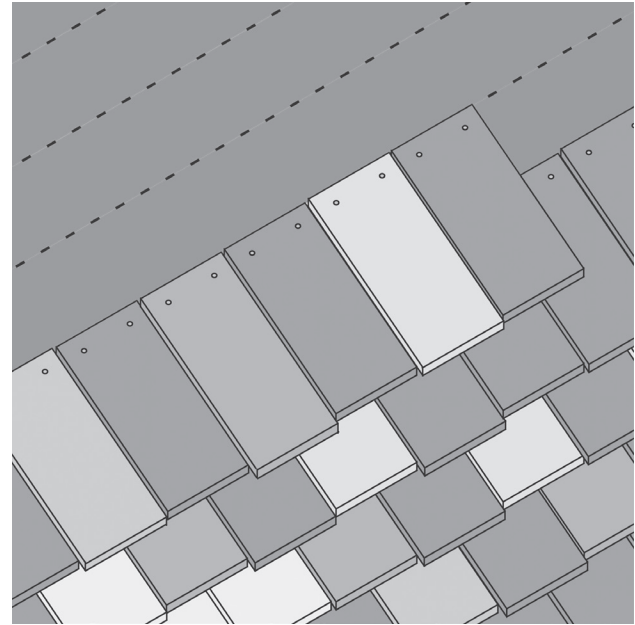

Figure 42.2 Rustic Shingle Tile

Rustic Shingle tiles are intentionally irregular in length. The tops should be lined up on the chalk line and the butt edge will vary by about 1/2".

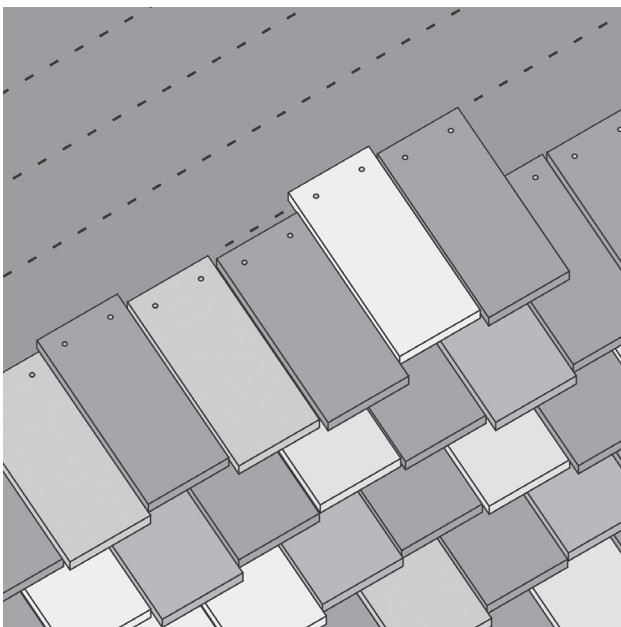

Figure 42.3 Staggered Layout

### Staggering

All Ludowici Shingle tiles can be staggered. Lay the Under Eaves and First Course in the standard manor. Strike second course and above chalk lines at 1/2" less than standard exposure. Lay the second course tiles and above in a random manor from 1/2" above the chalk line to 1/2" below. Be sure to maintain a minimum 2" head lap.

Be careful to lay the tiles randomly and not create a pattern. After 75-100 tiles are laid review from 50 feet to verify no visible pattern.

## Repair

To replace a broken or damaged tile do not use an exposed Copper strap. These are unsightly and can work loose allowing the replacement tile to slide out.

Ludowici's Quik-Tach™ Brackets are a quick, efficient and concealed method for tile replacement. Follow these steps:

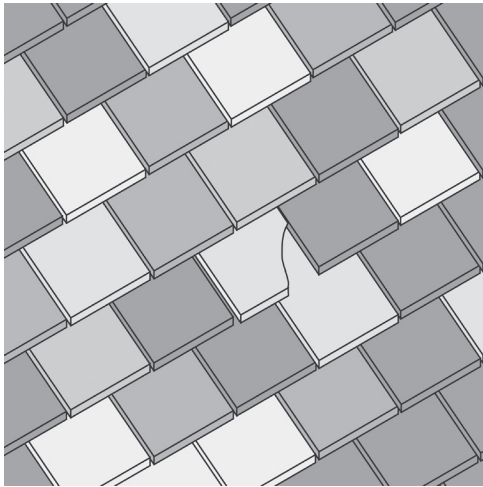

Figure 43.1 Existing Damaged Tile

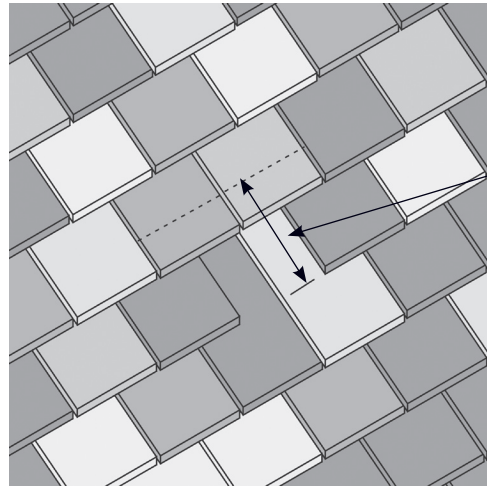

Figure 43.2 Remove Damaged Tile

Completely remove damaged tile and fasteners. A slate ripper will facilitate removal of fasteners. Measure the distance from the top of the course below to the bottom of the adjacent tile to the replacement.

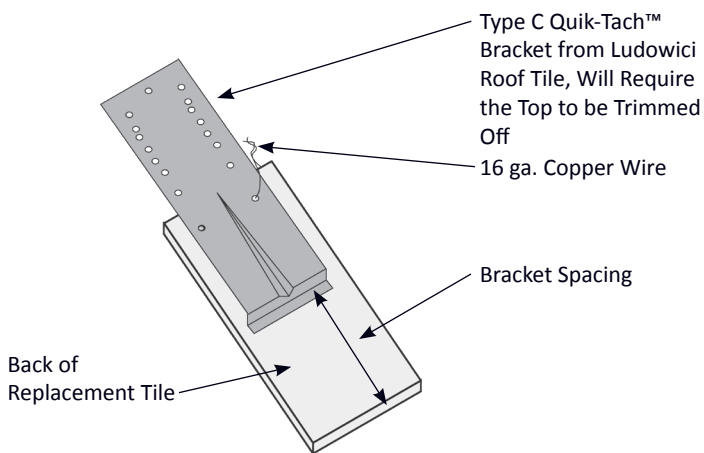

Figure 43.3 Replacement Tile with Quik-Tach™ Bracket

Align a Quik-Tach™ Bracket on the back of the replacement tile to the correct bracket spacing. Wire bracket to the replacement tile with 16 ga. Copper wire.

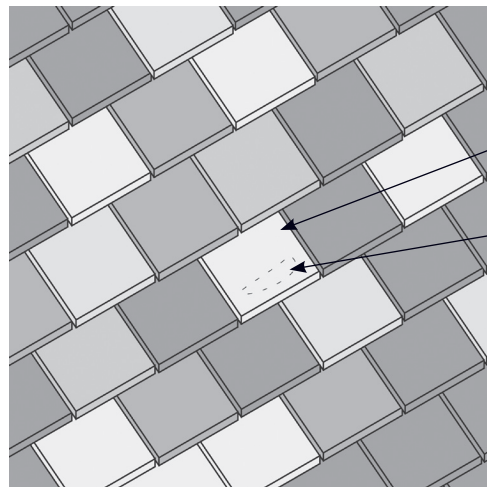

Figure 43.4 Finished Tile Replacement

Lift the tile in the course above and slide the replacement tile into place so the bracket engages the top of the tile below the replacement. Apply a small bead of Sealant or roofing Cement under replacement tile.

---

This manual includes the basic installation instructions from start to finish in an easy-to-read format. However, the applicator must always give consideration to regional climactic conditions and code requirements.

For alpine or tropical installations contact the Ludowici Technical Service Department for help.

**Have a question about how to install Ludowici tile?**

**Contact your local Ludowici Sales Representative or  
the Ludowici Technical Service Department at**

**1-800-945-8453**

**LUDOWICI®**

**4757 Tile Plant Rd.  
P.O. Box 69  
New Lexington, OH 43764  
1-800-945-8453  
[www.ludowici.com](http://www.ludowici.com)**