

Exercise 01: Fundamentals of the magnetic field

Acknowledgement: The following exercise is adapted from “Elektrische Maschinen und Antriebe Übungsbuch: Aufgaben mit Lösungsweg” by A. Binder, Springer, 2017

Task 1: Magnetic iron yoke

The iron core consists of thin single metal sheets with a cross-sectional area of $A = 900 \text{ mm}^2$ and with an air gap of $\delta = 3 \text{ mm}$. A simplified sketch is shown in Fig. 1.1. The material behavior of the selected iron is visualized in Fig. 1.2. The coil with N turns contains a direct current which results in a homogeneous magnetic flux density of $B_\delta = 1.8 \text{ T}$ in the air gap.

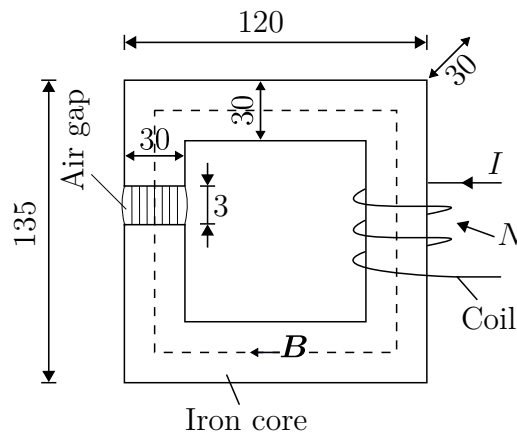

Figure 1.1: Simplified sketch of a magnetic iron core. All dimensions of the core are given in mm.

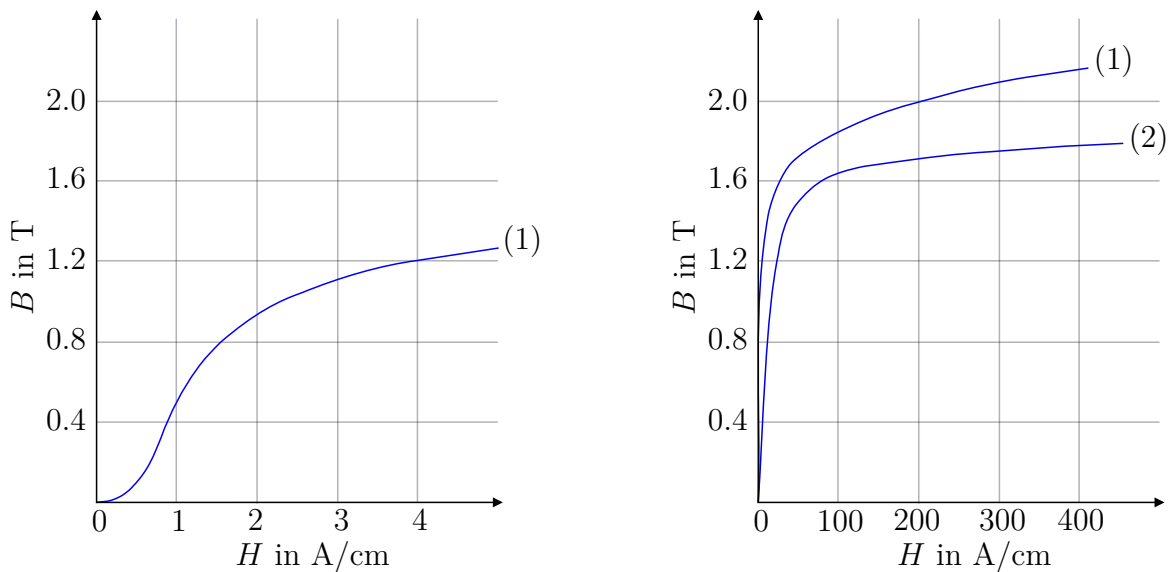

Figure 1.2: Direct current magnetization curves of electrical steel for (1) hot rolled processing with a thickness of 0.5 mm and (2) cold rolled processing with a thickness of 0.35 mm. The magnetization curve in figure on the left side is a zoomed version of material (1) for lower field strengths.

1.1 Calculate the magnetic flux ϕ_δ in the air gap.

Answer:

The area of the air gap is equal to the iron core area ($A_\delta = A = 900 \text{ mm}^2$). The calculation of the magnetic flux is defined as follows:

$$\phi_\delta = \int_S \mathbf{B} \, d\mathbf{S} = BA, \quad (1.1)$$

where \mathbf{B} is the magnetic flux density and \mathbf{S} is the surface area to integrate. The above integral could be simplified to $B \cdot A$ because the flux density is homogeneous and the integration surface S and the flux are perpendicular to each other. This results in

$$\phi_\delta = B_\delta A_\delta = 1.8 \text{ T} \cdot 900 \cdot 10^{-6} \text{ m}^2 = 1.62 \text{ mWb}. \quad (1.2)$$

1.2 How big is the magnetic flux density B_{Fe} in the iron core at the dotted line in Fig. 1.1? Neglect the leakage flux.

Answer:

Since the leakage flux is neglected, the fluxes ϕ_δ in the air gap and ϕ_{Fe} in the iron are equal. This results in the following equation:

$$\phi_\delta = \phi_{\text{Fe}} = A_\delta B_\delta = A_{\text{Fe}} B_{\text{Fe}}. \quad (1.3)$$

The equation from above is resorted to calculate the magnetic flux density:

$$B_{\text{Fe}} = B_\delta \frac{A_\delta}{A_{\text{Fe}}} = 1.8 \text{ T}. \quad (1.4)$$

1.3 What is the value of the permeability μ and the magnetic field strengths H_δ and H_{Fe} in the air gap and in the iron for the given operating point?

Answer:

The permeability in the air gap is equal to the permeability in the air, which is given with:

$\mu = \mu_0 = 4\pi \cdot 10^{-7} \frac{\text{Vs}}{\text{Am}}$. The magnetic field strength in the air gap is calculated with:

$$H_\delta = \frac{B_\delta}{\mu_0} = \frac{1.8 \text{ T}}{4\pi \cdot 10^{-7} \frac{\text{Vs}}{\text{Am}}} = 1432395 \frac{\text{A}}{\text{m}}. \quad (1.5)$$

The curve (1) on the left side in Fig. 1.2 shows for $B_{\text{Fe}} = 1.8 \text{ T}$ a magnetic field strength of $H_{\text{Fe}} = 80 \frac{\text{A}}{\text{cm}} = 8000 \frac{\text{A}}{\text{m}}$. With the field strength H_{Fe} the permeability of the iron is calculated:

$$\mu_{\text{Fe}} = \frac{B_{\text{Fe}}}{H_{\text{Fe}}} = \frac{1.8 \text{ T}}{8000 \text{ A/m}} = 0.000225 \frac{\text{Vs}}{\text{Am}}, \quad (1.6)$$

which is approximately 179 times μ_0 .

1.4 What is the required electromotive force $\theta = N \cdot I$ in the excitation coil to excite the flux density $B_\delta = 1.8 \text{ T}$?

Answer:

The electromotive force is calculated with Ampère's law along closed curve ∂S :

$$\theta = NI = H_\delta \delta + H_{\text{Fe}} l_{\text{Fe}}. \quad (1.7)$$

Therefore, the length of the magnetic path calculates as:

$$l_{\text{Fe}} = 2(120 - 30) + 2(135 - 30) - 3 = 387 \text{ mm}. \quad (1.8)$$

Hence, with the two equations from above, the electromotive force is calculated with:

$$\begin{aligned} \theta &= H_\delta \delta + H_{\text{Fe}} l_{\text{Fe}}. \\ &= 1432395 \text{ A/m} \cdot 0.003 \text{ m} + 8000 \text{ A/m} \cdot 0.387 \text{ m} \\ &= 7393 \text{ A}. \end{aligned} \quad (1.9)$$

1.5 What is the required current I if the coil has $N = 500$ turns?

Answer:

The current is calculated with:

$$I = \frac{\theta}{N} = \frac{7393 \text{ A}}{500} = 14.79 \text{ A}. \quad (1.10)$$

Task 2: Electromagnetic induction

A magnetic circuit (cf. Fig. 1.3a) has the dimension of $\delta = 3 \text{ mm}$, $b = l = 30 \text{ mm}$. The excitation coil with $N = 500$ turns is fed with an alternating current $i(t) = \hat{I} \sin(2\pi ft)$ with $f = 100 \text{ Hz}$ and $\hat{I} = 7.8 \text{ A}$. The permeability of the iron μ_{Fe} is assumed to be infinite and the flux leakage can be neglected. A quadratic, non-moving coil with a side length of 30 mm and $N_C = 10$ turns is within the air gap of the yoke. The orientation of the coil is shown in Fig. 1.3b.

2.1 Calculate the flux density $B_\delta(t)$ in the air gap. Sketch the trajectories of $i(t)$ and $B_\delta(t)$.

Answer:

Since the leakage flux is neglected, the fluxes ϕ_δ in the air gap and ϕ_{Fe} in the iron are equal ($\phi_\delta = \phi_{\text{Fe}}$). In addition, the area of the coil and the air gap area are identical ($A_{\text{Fe}} = A_\delta$). Therefore, the following relationship is made:

$$\phi_\delta = \phi_{\text{Fe}} = A_\delta B_\delta = A_{\text{Fe}} B_{\text{Fe}}. \quad (1.11)$$

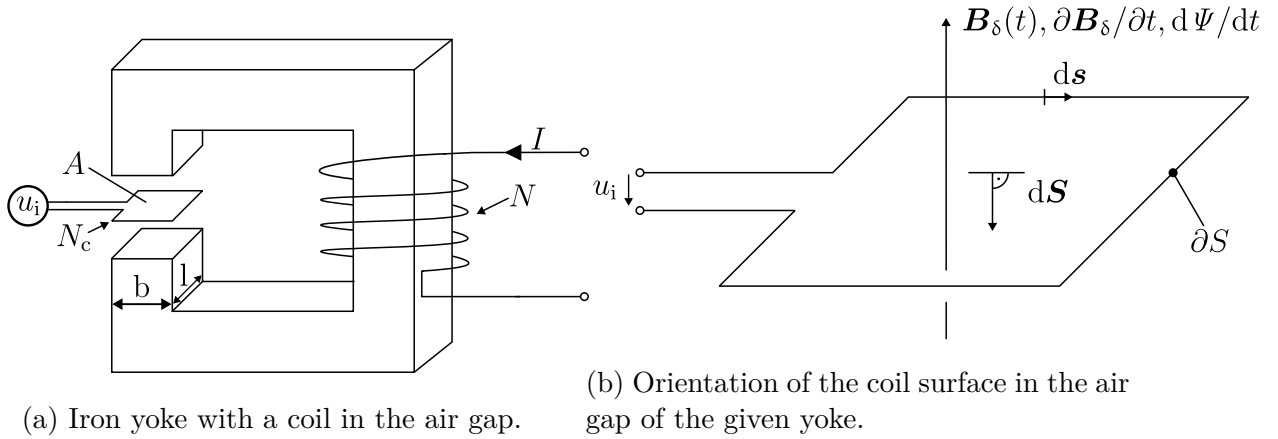

Figure 1.3: Iron yoke and coil orientation.

By resorting the equation from above, the flux density in the air gap is calculated:

$$B_{Fe} = B_{\delta} \frac{A_{\delta}}{A_{Fe}} = B_{\delta}. \quad (1.12)$$

The magnetic field strength calculates as:

$$H_{Fe} = \frac{B_{Fe}}{\mu_{Fe}} = 0, \quad (1.13)$$

which is zero due to the assumption of an infinite permeability in the iron path.

In the following equation, Ampère's law is given with:

$$\theta(t) = Ni(t) = H_{\delta}\delta + H_{Fe}l_{Fe}. \quad (1.14)$$

This equation simplifies by neglecting the magnetic field strength within the iron ($H_{Fe} = 0$) due to the infinite permeability. This leads to the following equation:

$$\theta(t) = H_{\delta}\delta = \frac{B_{\delta}\delta}{\mu_0}, \quad (1.15)$$

where $H_{\delta} = B_{\delta} / \mu_0$.

By rearranging the equation from above, the magnetic flux density in the air gap is calculated as follows:

$$B_{\delta}(t) = \frac{\mu_0 Ni(t)}{\delta}. \quad (1.16)$$

With the given values in the task, the time course of the magnetic flux density is expressed as:

$$B_{\delta}(t) = 4\pi \cdot 10^{-7} \cdot \frac{500 \cdot 7.8 \text{ A} \cdot \sin(2\pi \cdot 100 \text{ Hz} \cdot t)}{0.003 \text{ m}} = 1.63 \text{ T} \cdot \sin(2\pi \cdot 100 \text{ Hz} \cdot t). \quad (1.17)$$

In the upper part of Sol.-Fig. 1.1 the trajectory of the current is shown. In addition, the trajectory of the magnetic flux density is visualized in the lower part.

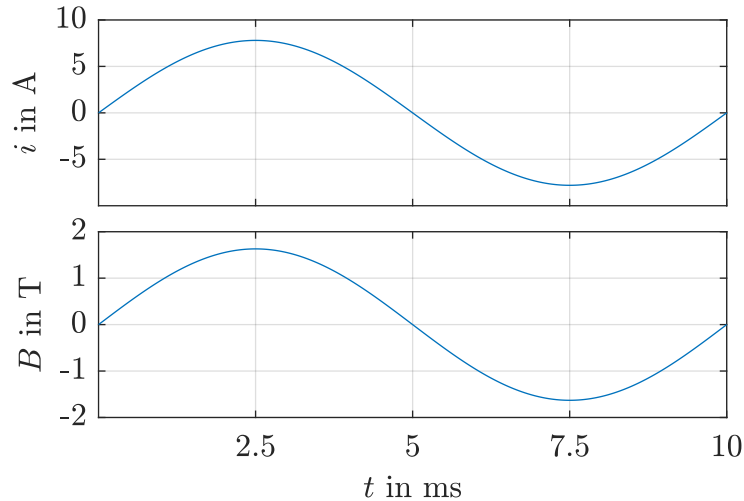

Solution Figure 1.1: Trajectories of the current $i(t)$ in the upper and the magnetic flux density $B(t)$ in the lower part of the figure.

2.2 How large is the magnetic flux linkage $\Psi(t)$ of the magnetic field generated by the excitation coil to the coil in the air gap?

Answer:

According to Fig. 1.3b, the direction of vector $d\mathbf{S}$ is in the opposite direction of the flux density vector \mathbf{B}_δ . Therefore, the flux linkage has a negative sign:

$$\psi(t) = N_c \phi(t) = -N_c A_\delta B_\delta(t). \tag{1.18}$$

With the given and calculated values, the flux linkage is defined with:

$$\psi(t) = -10 \cdot (30 \cdot 30) \cdot 10^{-6} \text{ m}^2 \cdot 1.63 \text{ T} \cdot \sin(2\pi \cdot 100 \text{ Hz} \cdot t) = -0.0147 \text{ Vs} \cdot \sin(2\pi \cdot 100 \text{ Hz} \cdot t). \tag{1.19}$$

2.3 How large is the induced voltage $u_i(t)$ of the coil in the air gap? Also, sketch the trajectory u_i .

Answer:

The induced voltage is the differential of the magnetic flux linkage and therefore, defined as:

$$u_i(t) = -\frac{d\psi(t)}{dt} = -2\pi f \hat{\Psi} \cos(2\pi f t). \tag{1.20}$$

In addition, the induced voltage is calculated with the previous calculated values:

$$u_i(t) = -2\pi \cdot 100 \text{ Hz} \cdot (-0.0147 \text{ Vs}) \cdot \cos(2\pi \cdot 100 \text{ Hz} \cdot t) = 9.2 \text{ V} \cdot \cos(2\pi \cdot 100 \text{ Hz} \cdot t). \tag{1.21}$$

In the upper part of Sol.-Fig. 1.2, the calculated current from the previous task is shown again. The induced voltage is visualized in the lower part of the figure.

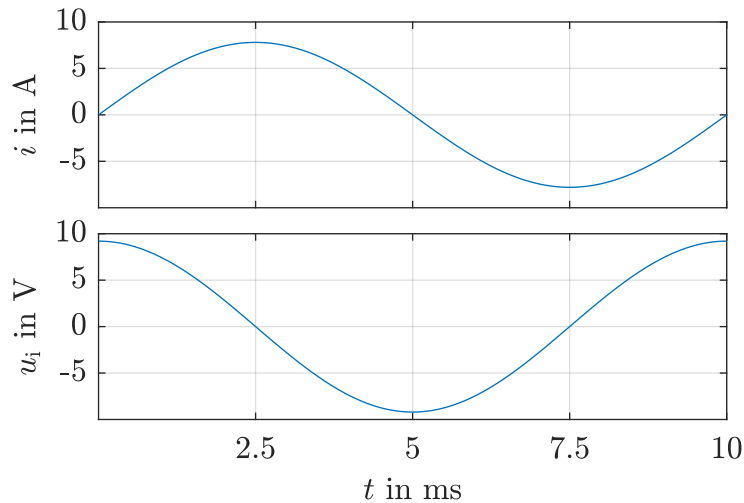

Solution Figure 1.2: Trajectories of the current $i(t)$ in the upper and the induced voltage $u_i(t)$ in the lower part of the figure.

2.4 Calculate the mutual inductance M between the excitation coil and the air gap coil.

Answer:

The mutual inductance is defined as follows:

$$M = M_{21} = \frac{\psi_2(t)}{i_1(t)} = \frac{\hat{\psi} \sin(2\pi ft)}{\hat{I} \sin(2\pi ft)} = \frac{\hat{\psi}}{\hat{I}} = \frac{-0.0147 \text{ Vs}}{7.8 \text{ A}} = -1.88 \text{ mH}. \quad (1.22)$$

Task 3: Moving current-carrying conductor in a magnetic field

An electrical conductor (length $l = 1 \text{ m}$, resistance $R = 0.2 \text{ }\Omega$) is connected via two flexible supply lines from a battery (open circuit voltage $U_{B0} = 12 \text{ V}$, internal resistance $R_{Bi} = 0.1 \text{ }\Omega$) and is excited with direct current I . The conductor is located in an air gap between two very long permanent magnets pole pieces, that are perpendicular to the conductor axis. The magnetic flux density directed downwards perpendicular to the conductor axis $B_\delta = 0.8 \text{ T}$ in the air gap. The self-inductance of the conductor and the wire connections is neglected.

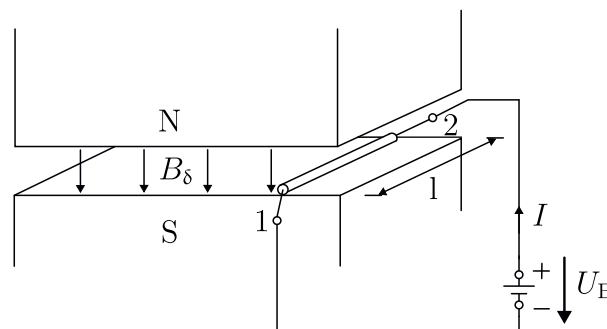

Figure 1.4: Current-carrying conductor in magnetic field.

3.1 Draw the electrical equivalent circuit diagram of the battery and resting conductor, and enter the direction of current flow I in the load convention style. How large is I ?

Answer:

As the magnetic field is constant over time, no induction occurs. Only the electrical battery voltage acts according to the equivalent circuit diagram in Sol.-Fig. 1.3. Hence, the current is calculated with:

$$I = \frac{U_{B0}}{R_{Bi} + R} = \frac{12 \text{ V}}{(0.1 + 0.2) \Omega} = 40 \text{ A.} \tag{1.23}$$

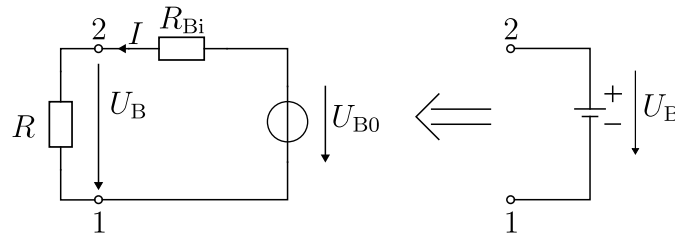

Solution Figure 1.3: Equivalent circuit diagram for the battery and resting conductor marked here with R .

3.2 In which direction shows the Lorentz force F on the conductor? How big is this force?

Answer:

The force F acts at right angles to the field and current flow direction, this means, in the direction of the air gap surface to the right, which is shown in Sol.-Fig. 1.4. Since the direction of current flow and field direction form a right angle with each other, the maximum possible force occurs:

$$F = IlB_\delta = 40 \text{ A} \cdot 1 \text{ m} \cdot 0.8 \text{ T} = 32 \text{ N.} \tag{1.24}$$

As the conductor is flexibly connected to the battery via flexible connections the force F in the air gap accelerates it to the right in its direction.

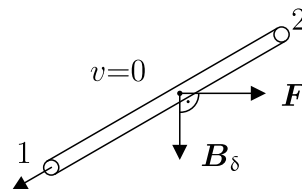

Solution Figure 1.4: Acting Lorentz force on the conductor in the air gap.

3.3 Draw the electrical equivalent circuit diagram for the combination of the moving conductor and feeding battery with the conditions at conductor side l . What additional electrical voltage occurs?

Answer:

If the conductor is moved by the force F at the speed v , the movement induction in the conductor

along the length l creates a movement field strength against the direction of the tangent vector:

$$\mathbf{E}_b = \mathbf{v} \times \mathbf{B}_\delta. \quad (1.25)$$

Therefore, between 2 and 1 the voltage u_i is induced:

$$u_i = \int_2^1 (\mathbf{v} \times \mathbf{B}_\delta) ds = - \int_2^1 v B_\delta ds = -v B_\delta l = U_i. \quad (1.26)$$

In the equivalent circuit diagram (Sol.-Fig. 1.5), the induced voltage acts in series with the battery voltage:

$$U_{B0} + U_i = (R_{Bi} + R)I = U_{B0} - v B_\delta l. \quad (1.27)$$

As long as $v B_\delta l$ is less than U_{B0} , is $I > 0$ and the driving force $F > 0$ remains effective. The induced voltage acts against the current direction I , which is the cause of the conductor movement through F , and therefore acts against the cause of its creation (Lenz's rule, Sol.-Fig. 1.5).

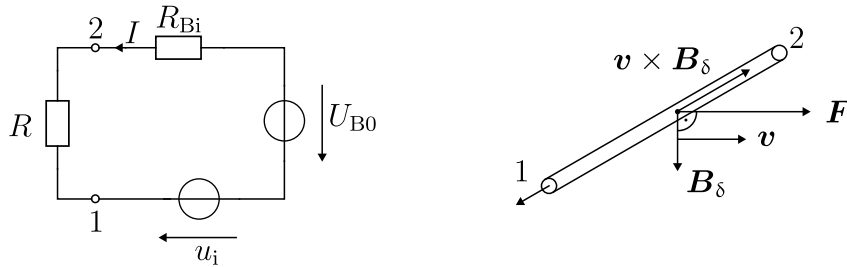

Solution Figure 1.5: Moving conductor with the induced voltage u_i as an external voltage, a) equivalent electrical circuit diagram, b) direction of the Lorentz force F .

3.4 To what final velocity v_0 is the conductor in the air gap accelerated by F if no mechanical braking force acts on it and if one considers the air gap as arbitrary long? How is the current I in the conductor after reaching the final velocity?

Answer:

The final velocity v_0 in the air gap is reached when, the sum of all forces acting on the conductor is zero ($\sum F = 0$), according to Newton's second axiom. Without mechanical forces from outside, this is this only true when $I = 0$ due to $F = I l B_\delta$. With the equivalent circuit from Sol.-Fig. 1.5 the following equation is defined:

$$U_{B0} = (R_{Bi} + R)I - U_i, \quad (1.28)$$

with $I = 0$, it arranges to:

$$U_{B0} = -U_i = v_0 B_\delta l. \quad (1.29)$$

Hence, the final velocity is calculated as:

$$v_0 = \frac{U_{B0}}{B_\delta l} = \frac{12 \text{ V}}{0.8 \text{ T} \cdot 1 \text{ m}} = 15 \frac{\text{m}}{\text{s}}. \quad (1.30)$$

At the final speed v_0 , the induced voltage and battery voltage canceled each other out, such that the current I is zero.

3.5 Assume that the conductor experiences a braking force due to friction $F_R = 10 \text{ N}$. To what final velocity v does the conductor now accelerate? What is the current I in the conductor?

Answer:

The final velocity v is reached when no further accelerating force acts on the conductor, i.e., when $F - F_R = 0$. The force F is defined as:

$$F = IlB_\delta = F_R = 10 \text{ N}. \quad (1.31)$$

By rearranging, the necessary current is calculated with:

$$I = \frac{10 \text{ Nm}}{1 \text{ m} \cdot 0.8 \text{ T}} = 12.5 \text{ A}. \quad (1.32)$$

With the voltage equation again from the equivalent circuit diagram:

$$U_{B0} = (R_{Bi} + R)I - u_i, \quad (1.33)$$

with

$$u_i = -vB_\delta l. \quad (1.34)$$

Hence, the velocity v calculates as follows:

$$v = \frac{U_{B0} - (R_{Bi} + R)I}{B_\delta l} = \frac{12 \text{ V} - 0.3 \Omega \cdot 12.5 \text{ A}}{0.8 \text{ T} \cdot 1 \text{ m}} = 10.31 \frac{\text{m}}{\text{s}}. \quad (1.35)$$

The Lorentz force and the friction force are visualized in Sol.-Fig. 1.6 after reaching the final speed.

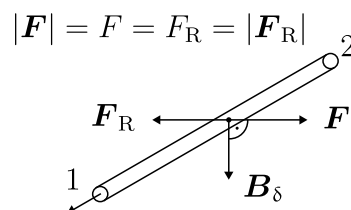

Solution Figure 1.6: Indicates the balance of forces after reaching the final speed.

3.6 What mechanical power P_m is required so that the conductor can move against the braking friction force $F_R = 10 \text{ N}$ with the final velocity v determined in task 3.5. Sketch the curves $v(I)$ and

$v(F)$ for a variable braking force F_R between v_0 and $v = 0$.

Answer:

The mechanical power is calculated as follows:

$$P_m = F_R v = 10 \text{ N} \cdot 10.31 \text{ m/s} = 103.1 \text{ W.} \tag{1.36}$$

The relationship between the current and the velocity is calculated with:

$$v = \frac{U_{B0} - (R_{Bi} + R)I}{B_\delta l}, \tag{1.37}$$

by changing the value of the current. This results in the left part of Sol.-Fig. 1.7. The corresponding force F is calculated as:

$$F = IlB_\delta, \tag{1.38}$$

and the resulting values are shown in der right part of Sol.-Fig. 1.7.

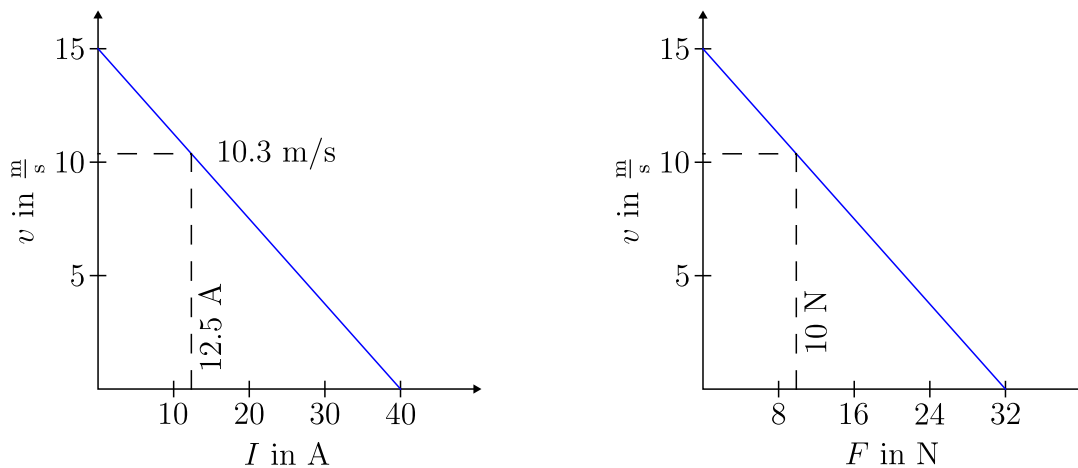

Solution Figure 1.7: Current and force of the conductor in relationship to the velocity.

3.7 What is the electrical power drawn from the battery P_{el} for the operating point from task 3.5? What is the efficiency η and the power loss P_l when converting electrical power into mechanical power? How does the conductor act as an electromechanical energy converter?

Answer:

The electrical power for the given operating point is calculated with:

$$P_{el} = U_{B0}I = 12 \text{ V} \cdot 12.5 \text{ A} = 150 \text{ W,} \tag{1.39}$$

which is used in the next step for the efficiency calculation:

$$\eta = \frac{P_{\text{out}}}{P_{\text{in}}} = \frac{P_{\text{m}}}{P_{\text{el}}} = \frac{103.1 \text{ W}}{150 \text{ W}} = 68.7 \%. \quad (1.40)$$

The total losses are calculated as follows:

$$P_1 = P_{\text{in}} - P_{\text{out}} = 150 \text{ W} - 103.1 \text{ W} = 46.9 \text{ W}. \quad (1.41)$$

The conductor moves against the braking external frictional force F_{R} , hence, it acts as a motor. It converts electrical energy from the battery into mechanical energy.

Exercise 02: DC machine

Acknowledgement: The following exercise is adapted from “Elektrische Maschinen und Antriebe Übungsbuch: Aufgaben mit Lösungsweg” by A. Binder, Springer, 2017

Task 1: Six-pole loop winding

A six-pole DC machine with an axial laminated core length $l_z = 120$ mm and a internal stator diameter $d_s = 190$ mm has an ideal pole coverage $\alpha = 0.7$ and a maximum radial magnetic air gap flux density $\hat{B}_\delta = 0.85$ T at no-load. The armature of the machine is equipped with a two-layer lap winding with a coil winding number $N_c = 20$ and $K = 31$ commutator segments. The machine has a interpole winding connected in series with the armature winding to improve commutation. The total resistance of the armature and interpole winding is $R_a = 0.14$ Ω .

1.1 What is the total number z_a of armature conductors?

Answer:

The total number is calculated as follows

$$z_a = 2KN_c = 2 \cdot 31 \cdot 20 = 1240, \quad (2.1)$$

with K number of commutator elements and N_c number of conductor turns per coil.

1.2 Calculate the induced voltage U_i at a rotational speed of $n = 4000$ 1/min.

Answer:

First, the pole pitch is calculated with

$$\tau_p = \frac{d_s \pi}{2p} = \frac{190 \text{ mm} \cdot \pi}{6} = 99.5 \text{ mm}, \quad (2.2)$$

where d_s is the inner stator diameter and p the pole pair number.

The induced voltage per armature conductor calculates as

$$U_{i,c} = \frac{\mu_0 N_f l_z d_a}{2\delta p} I_f \omega, \quad (2.3)$$

with N_f field conductor loops and the air gap length δ .

The total induced voltage is defined with

$$U_i = \frac{N_a \alpha}{2a} U_{i,c}, \quad (2.4)$$

with N_a armature conductor loops and the pole coverage α . For the lap winding, the number of parallel winding branches $2a$ is equal to the number of the magnetic poles $2p$, that leads to $a = 3$.

Hence, the total induced voltage is calculated by

$$U_i = \omega I_f \frac{\mu_0 \alpha N_f N_a l_z \tau_p}{2\pi \delta a}, \quad (2.5)$$

with

$$\hat{B}_\delta = \frac{\mu_0 N_f}{2\delta p} I_f, \quad (2.6)$$

resulting in

$$\begin{aligned}
 U_i &= \hat{B}_\delta \omega \frac{\alpha N_a l_z \tau_p p}{\pi a} \\
 &= 0.85 \text{ T} \cdot 2\pi \frac{4000}{60} \frac{1}{\text{s}} \cdot \frac{0.7 \cdot \frac{1240}{2} \cdot 0.12 \text{ m} \cdot 0.0995 \text{ m} \cdot 3}{\pi \cdot 3} = 587.3 \text{ V},
 \end{aligned} \quad (2.7)$$

where l_z is the length of the machine and \hat{B}_δ the maximum flux density in the air gap.

1.3 The machine operates as a motor. For this purpose, a voltage of $U_a = 600 \text{ V}$ is applied. How large is the armature current I_a ?

Answer:

Derived from the equivalent circuit diagram, the voltage equation is given with:

$$U_a = U_i + I_a R_a. \quad (2.8)$$

The above equation is resorted and solved for the armature current as follows:

$$I_a = \frac{U_a - U_i}{R_a} = \frac{(600 - 587.3) \text{ V}}{0.14 \text{ } \Omega} = 90.8 \text{ A}. \quad (2.9)$$

1.4 Calculate the Lorentz force per conductor F_c and per pole F_{pole} . Calculate in addition the resulting average electromagnetic torque T . An air gap of $\delta = 1 \text{ mm}$ is assumed.

Answer:

The current per armature conductor is calculated with:

$$I_c = \frac{I_a}{2a} = \frac{90.8 \text{ A}}{6} = 15.13 \text{ A}. \quad (2.10)$$

The Lorentz force per armature conductor is determined as:

$$F_c = \hat{B}_\delta l_z I_c = 0.85 \text{ T} \cdot 0.12 \text{ m} \cdot 15.13 \text{ A} = 1.54 \text{ N}. \quad (2.11)$$

With F_c the Lorentz force per pole is calculated with:

$$F_{\text{pole}} = \alpha \frac{z_a}{2p} F_c = 0.7 \cdot \frac{1240}{6} \cdot 1.54 \text{ N} = 222.8 \text{ N}. \quad (2.12)$$

The torque per conductor is defined as follows

$$T_c = F_c \frac{d_a}{2} = \frac{\mu_0 N_f l_z d_a}{8 \delta p a} I_f I_a, \quad (2.13)$$

with the outer armature diameter $d_a = d_s - 2\delta$.

Hence, the resulting average torque is given as

$$T = 2\alpha N_a T_c = \frac{\mu_0 \alpha N_f N_a l_z d_a}{4 \delta p a} I_f I_a, \quad (2.14)$$

with (2.6) resulting in the following equation

$$\begin{aligned}
 T &= \hat{B}_\delta \frac{\alpha N_a l_z d_a}{2a} I_a \\
 &= 0.85 \text{ T} \cdot \frac{0.7 \cdot \frac{1240}{2} \cdot 0.12 \text{ m} \cdot 0.188 \text{ m}}{2 \cdot 3} \cdot 90.8 \text{ A} = 125.9 \text{ Nm}.
 \end{aligned} \quad (2.15)$$

1.5 Calculate the motor losses. Assume that the iron losses and friction losses can be neglected as well as that the field excitation is produced via permanent magnets.

Answer:

Based on the assumptions, only the ohmic losses occur in the machine:

$$P_1 = P_{\text{Cu,a}} = R_a I_a^2 = 0.14 \Omega \cdot (90.8 \text{ A})^2 = 1154.2 \text{ W}. \quad (2.16)$$

1.6 Calculate the efficiency η for the given operating point.

Answer:

The electric power is defined with

$$P_{\text{el}} = U_a I_a = 600 \text{ V} \cdot 90.8 \text{ A} = 54480 \text{ W}, \quad (2.17)$$

and the mechanical output power as:

$$P_{\text{mech}} = T \omega = 125.9 \text{ Nm} \cdot 2\pi \cdot \frac{4000}{60} \frac{1}{\text{s}} = 52753 \text{ W}. \quad (2.18)$$

The efficiency results in:

$$\eta = \frac{P_{\text{mech}}}{P_{\text{el}}} = \frac{52753 \text{ W}}{54480 \text{ W}} = 96.8 \%. \quad (2.19)$$

Task 2: Design parameters of a DC machine

The separately-excited four-pole DC machine with a two-layer lap winding has a stator with the diameter of $d_s = 133$ mm and a length of $l_z = 80$ mm. The armature has $Q = 30$ slots, $u = 3$ commutators per slot and layer as well as $N_c = 9$ windings per armature coil. The maximum air gap flux density is $\hat{B}_\delta = 0.9$ T, the ideal pole coverage is $\alpha = 0.7$, and, the air gap width is $\delta = 1.5$ mm. The nominal speed of the machine is $n_n = 1440$ min⁻¹, with an armature current of $I_{a,n} = 22$ A. The excitation values are given with $I_f = 0.5$ A and $U_f = 230$ V.

2.1 What is the pole pitch τ_p and the flux per pole ϕ_δ ?

Answer:

The pole pitch calculates as follows

$$\tau_p = \frac{d_s \pi}{2p} = \frac{133 \text{ mm} \cdot \pi}{4} = 104.5 \text{ mm}, \quad (2.20)$$

with the inner stator diameter d_s and the pole pair number $p = 2$. The flux per pole is calculated as

$$\phi_\delta = \alpha \tau_p l_z \hat{B}_\delta = 0.7 \cdot 0.1045 \text{ m} \cdot 0.08 \text{ m} \cdot 0.9 \text{ T} = 5.265 \text{ mWb}, \quad (2.21)$$

where α represents the pole coverage, l_z is the axial length of the machine and the maximum flux density \hat{B}_δ in the air gap.

2.2 What is the number of commutator elements K , the total number of armature conductors z_a and the number of parallel armature branches $2a$.

Answer:

The number of commutator elements is calculated as

$$K = Qu = 30 \cdot 3 = 90, \quad (2.22)$$

with Q slots and the slot to commutator ration u . The total number of armature conductors is defined by

$$z_a = 2KN_c = 2 \cdot 90 \cdot 9 = 1620, \quad (2.23)$$

with K number of commutator elements and N_c number of conductor turns per coil.

For a lap winding, the number of poles are directly connected with the number of parallel branches, which results in:

$$2a = 2p = 4. \quad (2.24)$$

2.3 Determine the induced voltage U_i at nominal speed n_n and the electromagnetic torque T_n . What is the necessary armature voltage $U_{a,n}$ during motor operation mode, when $R_a = 1$ Ω ? How large is the motor output power, neglecting the friction and the soft magnetic material losses (hysteresis + eddy current)? Determine the no-load rotational speed n_0 at the fixed flux ϕ_δ .

Answer:

The induced voltage is calculated by

$$U_i = \omega I_f \frac{\mu_0 \alpha N_f N_a l_z \tau_p}{2\pi \delta a}, \quad (2.25)$$

with

$$\hat{B}_\delta = \frac{\mu_0 N_f}{2\delta p} I_f, \quad (2.26)$$

resulting in

$$\begin{aligned} U_i &= \hat{B}_\delta \omega \frac{\alpha N_a l_z \tau_p p}{\pi a} \\ &= 0.9 \text{ T} \cdot 2\pi \frac{1440}{60} \frac{1}{\text{s}} \cdot \frac{0.7 \cdot \frac{1620}{2} \cdot 0.08 \text{ m} \cdot 0.1045 \text{ m} \cdot 2}{\pi \cdot 2} = 204.8 \text{ V}. \end{aligned} \quad (2.27)$$

The average torque is given as

$$T_n = \frac{\mu_0 \alpha N_f N_a l_z d_a}{4\delta p a} I_f I_a, \quad (2.28)$$

with (2.26) resulting in the following equation

$$\begin{aligned} T &= \hat{B}_\delta \frac{\alpha N_a l_z d_a}{2a} I_a \\ &= 0.9 \text{ T} \cdot \frac{0.7 \cdot \frac{1620}{2} \cdot 0.08 \text{ m} \cdot 0.130 \text{ m}}{2 \cdot 2} \cdot 22 \text{ A} = 29.2 \text{ Nm}. \end{aligned} \quad (2.29)$$

The armature voltage $U_{a,n}$ at nominal speed is derived from the equivalent circuit diagram and therefore given with:

$$U_{a,n} = U_i + R_a I_n = 204.8 \text{ V} + 1 \Omega \cdot 22 \text{ A} = 226.8 \text{ V}. \quad (2.30)$$

The mechanical output power is defined with:

$$P_{\text{mech}} = T_n \omega = 29.2 \text{ Nm} \cdot 2\pi \cdot \frac{1440}{60} \frac{1}{\text{s}} = 4403 \text{ W}. \quad (2.31)$$

To calculate the maximum speed at no-load, the friction and soft magnetic losses are neglected. Therefore, the armature current is assumed to zero ($I_a = 0$) resulting in $U_i = U_a$. Hence, the voltage equation is given with:

$$U_i = U_a = \hat{B}_\delta \omega \frac{\alpha N_a l_z \tau_p p}{\pi a}. \quad (2.32)$$

By rearranging the equation from above, the no-load speed is calculated as follows:

$$n = \frac{U_a \pi a}{\hat{B}_\delta \alpha N_a l_z \tau_p p 2\pi} = \frac{226.8 \text{ V} \cdot \pi \cdot 2}{0.9 \text{ T} \cdot 0.7 \cdot \frac{1620}{2} \cdot 0.08 \text{ m} \cdot 0.1045 \text{ m} \cdot 2 \cdot 2\pi} = 26.8 \frac{1}{\text{s}} = 1607 \frac{1}{\text{min}}. \quad (2.33)$$

2.4 How many brush pairs does the machine have? How big is the current per brush? What is the circumferential speed of the armature under consideration of δ ?

Answer:

The machine has two brush pairs to meet the pole pair number, which are electrical parallel connected. At the nominal operation point, the current per brush is calculated as follows

$$I_b = \frac{I_{a,n}}{a} = \frac{22 \text{ A}}{2} = 11 \text{ A}, \quad (2.34)$$

with $a = p = 2$ due to the lap winding.

The outer diameter of the armature is determined with

$$d_a = d_s - 2\delta = 133 \text{ mm} - 2 \cdot 1.5 \text{ mm} = 130 \text{ mm}, \quad (2.35)$$

and therefore, the circumferential speed of the armature calculates with:

$$v_a = d_a \pi n_n = 0.13 \text{ m} \cdot \pi \cdot \frac{1440}{60} \frac{1}{\text{s}} = 9.8 \frac{\text{m}}{\text{s}} = 35.3 \frac{\text{km}}{\text{h}}. \quad (2.36)$$

2.5 Determine the necessary excitation with ideal iron path ($\mu_r \rightarrow \infty$) per pole. What is the number of necessary windings for each of the four coils of the excitation of the stator. Considering a real motor, is the excitation larger or smaller?

Answer:

The total field is calculated as follows

$$\theta_f = \hat{H}_\delta \delta = \frac{\hat{B}_\delta}{\mu_0} \delta = \frac{0.9 \text{ T}}{4\pi \cdot 10^{-7} \frac{\text{Vs}}{\text{Am}}} \cdot 0.0015 \text{ m} = 1074.3 \text{ A}, \quad (2.37)$$

with the magnetic field strength H_δ in the air gap. The relationship between the total excitation and the excitation per pole is

$$\theta_f = N_{f,\text{pole}} I_f, \quad (2.38)$$

which results in the necessary windings per pole

$$N_{f,\text{pole}} = \frac{\theta_f}{I_f} = \frac{1074.3 \text{ A}}{0.5 \text{ A}} = 2148.6, \quad (2.39)$$

with the field current I_f . This results in 2149 necessary turns.

By considering iron saturation μ_r is not constant anymore, see therefore the magnetization curves from the lecture. This results in lower value of μ_r compared to the previous assumption in this task ($\mu_r \rightarrow \infty$) and therefore the effective magnetic reluctance along the field excitation path increases. To overcome this and to provide the same effective excitation field, the field winding's MMF need to be increased by additional winding turns compared to the previous calculation.

2.6 Determine the efficiency η_a of the armature and the resulting total efficiency η . Are these losses larger or smaller for real motors? Why? Give an explanation.

Answer:

The electrical input power is calculated as follows:

$$P_{el,a} = U_a I_{a,n} = 226.8 \text{ V} \cdot 22 \text{ A} = 4990 \text{ W}. \quad (2.40)$$

Hence, the armature efficiency is determined with:

$$\eta_a = \frac{P_{mech}}{P_{el,a}} = \frac{4503 \text{ W}}{5031.4 \text{ W}} = 0.895 = 89.5 \%. \quad (2.41)$$

The field losses are calculated as

$$P_{el,f} = U_f I_f = 230 \text{ V} \cdot 0.5 \text{ A} = 115 \text{ W}, \quad (2.42)$$

which leads to the total efficiency:

$$\eta = \frac{P_{mech}}{P_{el,a} + P_{el,f}} = \frac{4403 \text{ W}}{4990 \text{ W} + 115 \text{ W}} = 0.862 = 86.2 \%. \quad (2.43)$$

The real losses are higher due to the air and bearing friction as well as the soft magnetic material losses (hysteresis + eddy current) which have been neglected in the above model calculation but which are present in a real machine.

2.7 The motor should be operated with a constant armature voltage of $U_{a,n} = 230 \text{ V}$ in the flux-weakening range with $T = 15 \text{ Nm}$. What is the flux per pole ϕ_{pole} and the armature current I_a ? How large is the resulting efficiency η , if the utilized iron shows no saturation and required field weakening is reached through reducing the field voltage U_f .

Answer:

The armature voltage is calculated as

$$U_a = U_i + R_a I_a = \omega \psi'_f + R_a I_a, \quad (2.44)$$

with $I_a = \frac{T}{\psi'_f}$ resulting in:

$$U_a = \omega \psi'_f + \frac{R_a T}{\psi'_f}. \quad (2.45)$$

This equation is reformed to the following

$$(\psi'_f)^2 - \frac{U_a}{\omega} \psi'_f + \frac{R_a T n}{\omega} = 0, \quad (2.46)$$

which represents a quadratic equation, that is solved in the following form:

$$x^2 + Px + Q = 0. \quad (2.47)$$

The solution is given as follows

$$x_{1,2} = -\frac{P}{2} \pm \sqrt{\left(\frac{P}{2}\right)^2 - Q}, \quad (2.48)$$

with

$$P = -\frac{U_a}{\omega}, \quad (2.49)$$

which is applied according to the equation:

$$\frac{P}{2} = -\frac{230 \text{ V}}{4\pi \cdot \frac{1900}{60} \frac{1}{\text{s}}} = 0.578 \text{ Vs}. \quad (2.50)$$

The parameter Q is defined by:

$$Q = \frac{R_a T_n}{\omega} = \frac{1 \Omega \cdot 15 \text{ Nm}}{2\pi \cdot \frac{1900}{60} \frac{1}{\text{s}}} = 0.0754 \text{ (Vs)}^2. \quad (2.51)$$

Hence, the solution is calculated as follows

$$\begin{aligned} (\psi'_f)_{1,2} &= \frac{U_a}{2\omega} \pm \sqrt{\left(\frac{U_a}{2\omega}\right)^2 - \frac{R_a T_n}{\omega}}, \\ (\psi'_f)_{1,2} &= 0.578 \pm \sqrt{(0.578 \text{ Vs})^2 - 0.0754 \text{ Vs}}, \end{aligned} \quad (2.52)$$

with two possible solution due to the quadratic equation. Therefore, both solutions must be evaluated, starting with $(\psi'_f)_1 = 0.07 \text{ Vs}$. The corresponding current is calculated by:

$$I_a = \frac{T_n}{(\psi'_f)_1} = \frac{15 \text{ Nm}}{0.07 \text{ Vs}} = 214.3 \text{ A}. \quad (2.53)$$

Testing the second solution $(\psi'_f)_2 = 1.09 \text{ Vs}$ results in

$$I_a = \frac{T_n}{(\psi'_f)_2} = \frac{15 \text{ Nm}}{1.09 \text{ Vs}} = 13.76 \text{ A}, \quad (2.54)$$

which is the right solution due to the lower current.

The corresponding flux per pole is calculated with:

$$\phi_{\text{pole}} = \frac{(\psi'_f)_2}{\frac{z_a}{2\pi}} = \frac{1.09 \text{ Vs}}{\frac{1620}{2\pi}} = 4.23 \text{ mVs}. \quad (2.55)$$

The relationship to the previously calculated flux per pole ϕ_δ is defined as follows

$$\frac{\phi_{\text{pole}}}{\phi_\delta} = \frac{4.23 \text{ mVs}}{5.265 \text{ mVs}} = 0.803 = 80.3 \%. \quad (2.56)$$

In the following, the armature current is set in relation to the nominal current as:

$$\frac{I_a}{I_{a,n}} = \frac{13.76 \text{ A}}{22 \text{ A}} = 0.63 = 63 \%. \quad (2.57)$$

Hence, the electrical input power is calculated with

$$P_{\text{el,a}} = U_a I_a = 230 \text{ V} \cdot 13.76 \text{ A} = 3164.8 \text{ W}, \quad (2.58)$$

and the mechanical power with the given values in the task description by:

$$P_{\text{mech}} = T\omega = 15 \text{ Nm} \cdot 2\pi \cdot \frac{1900}{60} \frac{1}{\text{s}} = 2984.5 \text{ W}. \quad (2.59)$$

The given operating point is located in the flux-weakening range and, therefore, the excitation values and the corresponding losses are changed. This leads to lower excitation losses as follows

$$\frac{P_{\text{el,f}}}{P_{\text{el,f,n}}} = \frac{R_f I_f^2}{R_f I_{f,n}^2} = \frac{I_f^2}{I_{f,n}^2}, \quad (2.60)$$

with

$$\frac{\phi_{\text{pole}}}{\phi_\delta} = \frac{I_f^2}{I_{f,n}^2} = 0.803^2. \quad (2.61)$$

This results in:

$$P_{\text{el,f}} = P_{\text{el,f,n}} \left(\frac{I_f}{I_{f,n}} \right)^2 = 115 \text{ W} \cdot (0.803)^2 = 74.2 \text{ W}. \quad (2.62)$$

The efficiency is given by:

$$\eta = \frac{P_{\text{mech}}}{P_{\text{el,a}} + P_{\text{el,f}}} = \frac{2984.5 \text{ W}}{3164.8 \text{ W} + 74.2 \text{ W}} = 0.921 = 92.1 \%. \quad (2.63)$$

Task 3: Submarine with DC machine

A four-pole DC machine on the board of a submarine with $U_{a,n} = 440 \text{ V}$, $P_n = 65 \text{ kW}$, $n_n = 1300 \text{ min}^{-1}$ has an efficiency of $\eta_n = 0.9$. The total losses P_l are separated in the ohmic losses $P_{\text{Cu,a}}$ in the armature with 75 % and the soft magnetic material, friction, and additional losses ($P_{\text{Fe}} + P_{\text{fr+add}}$) with 25 % of the total losses P_l . The field excitation losses are neglected in the following.

3.1 Calculate the armature current $I_{a,n}$, the torque T_n , the losses $P_{\text{Cu,a}}$ and $P_{\text{fr+add}}$, the armature winding resistance R_a and the no-load speed n_0 .

Answer:

The armature current calculates as follows

$$I_{a,n} = \frac{P_n / \eta_n}{U_{a,n}} = \frac{65 \text{ kW} / 0.9}{440 \text{ V}} = 164.1 \text{ A}, \quad (2.64)$$

with a nominal mechanical power of P_n , the efficiency η_n and the voltage $U_{a,n}$. Hence, the torque is determined with:

$$T_n = \frac{P_n}{\omega_n} = \frac{65 \text{ kW}}{2\pi \cdot \frac{1300}{60} \frac{1}{s}} = 477.5 \text{ Nm.} \quad (2.65)$$

The efficiency is given with

$$\eta_n = \frac{P_n}{P_n + P_1}, \quad (2.66)$$

where P_1 are the losses of the machine. To calculate them, the equation is rearranged as follows:

$$P_1 = \left(\frac{1}{\eta_n} - 1 \right) P_n = \left(\frac{1}{0.9} - 1 \right) \cdot 65 \text{ kW} = 7222 \text{ W.} \quad (2.67)$$

As described in the task, the copper losses are defined by

$$P_{\text{Cu,a}} = 0.75P_1 = 0.75 \cdot 7222 \text{ W} = 477.5 \text{ W}, \quad (2.68)$$

and, therefore, the other losses yield as follows:

$$P_{\text{Fe}} + P_{\text{fr+add}} = 0.25P_1 = 0.25 \cdot 7222 \text{ W} = 1805.5 \text{ W.} \quad (2.69)$$

The resistance of the armature calculates with

$$P_{\text{Cu,a}} = R_a I_{a,n}^2, \quad (2.70)$$

which is resorted to the following:

$$R_a = \frac{P_{\text{Cu,a}}}{I_{a,n}^2} = \frac{5416.7 \text{ W}}{(164.1 \text{ A})^2} = 0.201 \text{ } \Omega. \quad (2.71)$$

The voltage is determined according to the equivalent circuit diagram by

$$U_a = U_i + R_a I_{a,n}, \quad (2.72)$$

and, therefore, the induced voltage is calculated with

$$U_i = U_a - R_a I_{a,n} = 440 \text{ V} - 0.201 \text{ } \Omega \cdot 164.1 \text{ A} = 407 \text{ V.} \quad (2.73)$$

In addition, the induced voltage is defined as

$$U_i = \omega \psi'_f, \quad (2.74)$$

which is used to calculate the flux linkage as follows:

$$\psi'_f = \frac{U_i}{\omega} = \frac{407 \text{ V}}{2\pi \cdot \frac{1300}{60} \frac{1}{s}} = 2.99 \text{ Vs.} \quad (2.75)$$

To calculate the maximum speed at no-load, the friction and soft magnetic losses are neglected. Therefore, the armature current is assumed to zero ($I_a = 0$) resulting in $U_i = U_{a,n}$, which leads to

$$\omega = \frac{U_{a,n}}{\psi'_f}, \quad (2.76)$$

resulting in

$$n_0 = \frac{U_{a,n}}{\psi'_f 2\pi} = \frac{440 \text{ V}}{2.99 \text{ Vs} \cdot 2\pi} = 23.42 \frac{1}{\text{s}}, \quad (2.77)$$

which is a no-load speed of $n_0 = 1405 \text{ min}^{-1}$.

3.2 Determine the value of the additional starter resistor R_d , such that the start-up torque T_1 at $U_a = U_{a,n}$ is limited to 150 % of the nominal torque.

Answer:

As described in the task, the torque is set by

$$T_1 = 1.5T_n = \psi'_f I_{a,1}, \quad (2.78)$$

and at machine standstill, the voltage is defined as:

$$U_{a,n} = (R_a + R_d) I_{a,1}. \quad (2.79)$$

Therefore, the starter resistor is calculated with

$$R_d = \frac{U_{a,n}}{I_{a,1}} - R_a = \frac{U_{a,n} \psi'_f}{1.5T_n} - R_a = \frac{440 \text{ V} \cdot 2.99 \text{ Vs}}{1.5 \cdot 477.5 \text{ Nm}} - 0.201 \Omega = 1.635 \Omega. \quad (2.80)$$

Hence, the starter current is determined with:

$$I_{a,1} = \frac{1.5T_n}{\psi'_f} = \frac{1.5 \cdot 477.5 \text{ Nm}}{2.99 \text{ Vs}} = 239.7 \text{ A}. \quad (2.81)$$

3.3 With a power electronic converter, the armature voltage U_a is reduced to $0.8 U_{a,n}$. How large is the rotational speed n with the fixed flux ϕ_δ at the torque $T = 0.5 T_n$?

Answer:

The equation for the reduced armature voltage is given as follows

$$U_a = 0.8U_{a,n} = \omega \psi'_f + R_a I_a, \quad (2.82)$$

and the reduced torque results in a lower armature current, which is calculated with:

$$I_a = \frac{0.5T_n}{\psi'_f}. \quad (2.83)$$

With this two equations from above, the speed is calculated below:

$$\begin{aligned}
 n &= \frac{0.8U_{a,n} - \frac{R_a 0.5T_n}{\psi'_f}}{2\pi\psi'_f} = \frac{0.8 \cdot 440 \text{ V} - \frac{0.201 \text{ } \Omega \cdot 0.5 \cdot 477.5 \text{ Nm}}{2.99 \text{ Vs}}}{2\pi \cdot 2.99 \text{ Vs}} \\
 &= 17.89 \frac{1}{\text{s}} = 1073.6 \frac{1}{\text{min}}.
 \end{aligned} \tag{2.84}$$

3.4 After the submarine surfaced, the machine is now used as a generator to charge the batteries powering with marine diesel at the speed $n_n = 1530 \text{ min}^{-1}$. What is the no-load induced voltage? How big is the armature voltage U_a at $I_a = I_{a,n}$ ($\phi = \phi_\delta$)?

Answer:

The induced voltage is calculated with:

$$U_i = U_0 = \omega\psi'_f = 2\pi \cdot \frac{1530}{60} \frac{1}{\text{s}} \cdot 2.99 \text{ Vs} = 478.7 \text{ V}. \tag{2.85}$$

To determine the armature voltage, the ohmic voltage drop is taken into account as given below:

$$U_a = U_0 - I_{a,n}R_a = 478.7 \text{ V} - 164.1 \text{ A} \cdot 0.201 \text{ } \Omega = 445.8 \text{ V}. \tag{2.86}$$

3.5 How large is the voltage U_a at $\phi = 0.7 \phi_\delta$ and $I_a = I_{a,n}/2$?

Answer:

The armature voltage is calculated in the following with:

$$U_a = U_0 \frac{\phi}{\phi_\delta} - \frac{1}{2} I_{a,n} R_a = 478.7 \text{ V} \cdot 0.7 - 0.5 \cdot 164.1 \text{ A} \cdot 0.201 \text{ } \Omega = 318.6 \text{ V}. \tag{2.87}$$

3.6 What is the rotational speed n such that the generator with the nominal flux ϕ_δ and the nominal current $I_{a,n}$ induces an armature voltage of U_0 ?

Answer:

The basic equation is the same as in the previous subtasks and is defined as:

$$U_a = U_0 = \omega\psi'_f - R_a I_{a,n}. \tag{2.88}$$

After reformulation the speed is calculated as shown below:

$$n = \frac{U_0 + R_a I_n}{2\pi\psi'_f} = \frac{478.7 \text{ V} + 0.201 \text{ } \Omega \cdot 164.1 \text{ A}}{2\pi \cdot 2.99 \text{ Vs}} = 27.25 \frac{1}{\text{s}} = 1635 \frac{1}{\text{min}}. \tag{2.89}$$

Exercise 03: DC machine and transformer

Acknowledgement: The following exercise is adapted from “Grundlagen der Elektrotechnik Teil B” by J. Böcker, Paderborn University, 2020

Task 1: Series DC machine with DC and AC voltage supply

In this task, a ten-pole series DC machine is given. The supply voltage is $U_{\text{DC}} = 325 \text{ V}$ with an electrical input power of $P_{\text{el}} = 500 \text{ W}$ at a nominal speed of 1600 min^{-1} .

1.1 Calculate the nominal torque T_{n} and the nominal armature current $I_{\text{a,n}}$ for an effective field inductance of $L'_{\text{f}} = 1.24 \text{ H}$.

Answer:

The armature current is calculated with:

$$I_{\text{a,n}} = \frac{P_{\text{el}}}{U_{\text{DC}}} = \frac{500 \text{ W}}{325 \text{ V}} = 1.54 \text{ A.} \quad (3.1)$$

Hence, the nominal torque calculates as:

$$T_{\text{n}} = L'_{\text{f}} I_{\text{a,n}}^2 = 1.21 \text{ H} \cdot (1.54 \text{ A})^2 = 2.9 \text{ Nm.} \quad (3.2)$$

1.2 Determine the efficiency for the given operating point.

Answer:

The mechanical power is given with

$$P_{\text{mech}} = T_{\text{n}} \omega_{\text{n}} = 2.9 \text{ Nm} \cdot 2\pi \cdot \frac{1600}{60} \frac{1}{\text{s}} = 486 \text{ W.} \quad (3.3)$$

The electrical input power is known from the task description, which results in the following efficiency:

$$\eta = \frac{P_{\text{mech}}}{P_{\text{el}}} = \frac{486 \text{ W}}{500 \text{ W}} = 0.972 = 97.2 \%. \quad (3.4)$$

1.3 The machine is manufactured with a lap winding, which contains $N_{\text{a}} = 40$ armature windings. The number of field windings $N_{\text{f}} = 10$ is given too. Calculate the field inductance L_{f} .

Answer:

The field inductive is calculated with:

$$L_{\text{f}} = L'_{\text{f}} \frac{N_{\text{f}} a \pi}{N_{\text{a}} 2p} = 1.24 \text{ H} \cdot \frac{10}{40} \cdot \frac{5\pi}{2 \cdot 5} = 0.49 \text{ H,} \quad (3.5)$$

where $a = p$ due to the lap winding.

1.4 Calculate the peak and the average torque of the machine for an alternating voltage supply with $U = 230 \text{ V}$ and a frequency $f = 50 \text{ Hz}$. Assume, that the armature inductivity is given as $L_a = L_f \frac{N_a}{N_f}$. Interpret the results.

Answer:

The total series inductance is calculated with:

$$L = L_a + L_f = L_f \frac{N_a}{N_f} + L_f = 0.49 \text{ H} \cdot \frac{40}{10} + 0.49 \text{ H} = 2.43 \text{ H}. \quad (3.6)$$

The effective resistance can be calculated on the previously provided information from the DC operation case:

$$R'(\omega) = \frac{U_{\text{DC}}}{I_{a,n}} = \frac{325 \text{ V}}{1.54 \text{ A}} = 211 \Omega. \quad (3.7)$$

Therefore, the peak torque is calculated with:

$$\hat{T} = 2L_f' \frac{U^2}{R'(\omega)^2 + \omega_{el}^2 L^2} = 2 \cdot 1.24 \text{ H} \cdot \frac{(230 \text{ V})^2}{(211 \Omega)^2 + (2\pi \cdot 50 \text{ Hz})^2 \cdot (2.43 \text{ H})^2} = 0.21 \text{ Nm}. \quad (3.8)$$

The average torque is defined as:

$$T = \frac{1}{2} \hat{T} = \frac{1}{2} \cdot 0.21 \text{ Nm} = 0.11 \text{ Nm}. \quad (3.9)$$

The machine in this task is designed for a DC voltage supply, which is shown indirectly with the good efficiency. By considering an AC voltage supply, the high inductance value increases the induced voltage significantly. Hence, no voltage margin remains between the terminal voltage and the induced voltage, which results in a small armature current and a small corresponding torque. To complete this task: When the series DC machine is designed for a DC voltage supply, the operation with an AC voltage does not make sense but requires an electromagnetic redesign of the machine.

Task 2: Ideal transformer

Given is an ideal (no losses, no flux leakage) single-phase transformer with an apparent power of 5 kVA. The voltage U_1 on the primary side is 230 V and on the secondary side $U_2 = 110 \text{ V}$. The transformer is operated at a frequency of 50 Hz.

2.1 Determine the turn ratio \ddot{u} of the transformer.

Answer:

The turn ratio of the transformer is given with:

$$\ddot{u} = \frac{U_1}{U_2} = \frac{230 \text{ V}}{110 \text{ V}} = 2.1. \quad (3.10)$$

2.2 The transformer is operated at its rated operating point. Calculate the current through the primary and secondary winding.

Answer:

The current through the primary winding is calculated as

$$I_{1,n} = \frac{S}{U_1} = \frac{5 \text{ kW}}{230 \text{ V}} = 21.4 \text{ A}, \quad (3.11)$$

with the apparent power S given in the task. Due to the ideal transformer, the current through the secondary winding is determined in the same way as follows:

$$I_{2,n} = \frac{S}{U_2} = \frac{5 \text{ kW}}{110 \text{ V}} = 45.5 \text{ A}. \quad (3.12)$$

2.3 Now, the transformer is operated on the secondary side with the rated terminal voltage and delivers an active power of $P_2 = 3.2 \text{ kW}$ with a power factor of $\cos \varphi = 0.8$ (inductive). Calculate the current of the primary and secondary winding.

Answer:

The apparent power is calculated with as:

$$S = \frac{P_2}{\cos \varphi} = \frac{3.2 \text{ kW}}{0.8} = 4 \text{ kVA}. \quad (3.13)$$

Due to the loss-free transformer, the calculated apparent power is the same on the primary and secondary side. Hence, the primary and secondary currents are determined by:

$$\begin{aligned} I_2 &= \frac{S}{U_2} = \frac{4 \text{ kVA}}{110 \text{ V}} = 36.4 \text{ A}, \\ I_1 &= \frac{S}{U_1} = \frac{4 \text{ kVA}}{230 \text{ V}} = 17.4 \text{ A}. \end{aligned} \quad (3.14)$$

Task 3: Magnetization current

A transformer has a primary voltage of $U_1 = 230 \text{ V}$ and a secondary voltage of $U_2 = 48 \text{ V}$ with a frequency of $f = 50 \text{ Hz}$. The area of the iron core is $S_{\text{Fe}} = 6 \text{ cm}^2$. The average length of the iron core is given with $l_{\text{Fe}} = 30 \text{ cm}$. A simplified sketch of the transformer is shown on the left side in Fig. 3.1 below. On the right side, the magnetization curve of the utilized iron is visualized.

3.1 How many winding turns are necessary, such that the maximal flux density in the iron is $\hat{B} = 0.8 \text{ T}$? Hint: For the calculation of the winding turns, the magnetic coupling of the coils is assumed to be ideal. In addition, winding resistances are also neglected. Draw the T-equivalent circuit diagram for the given assumptions.

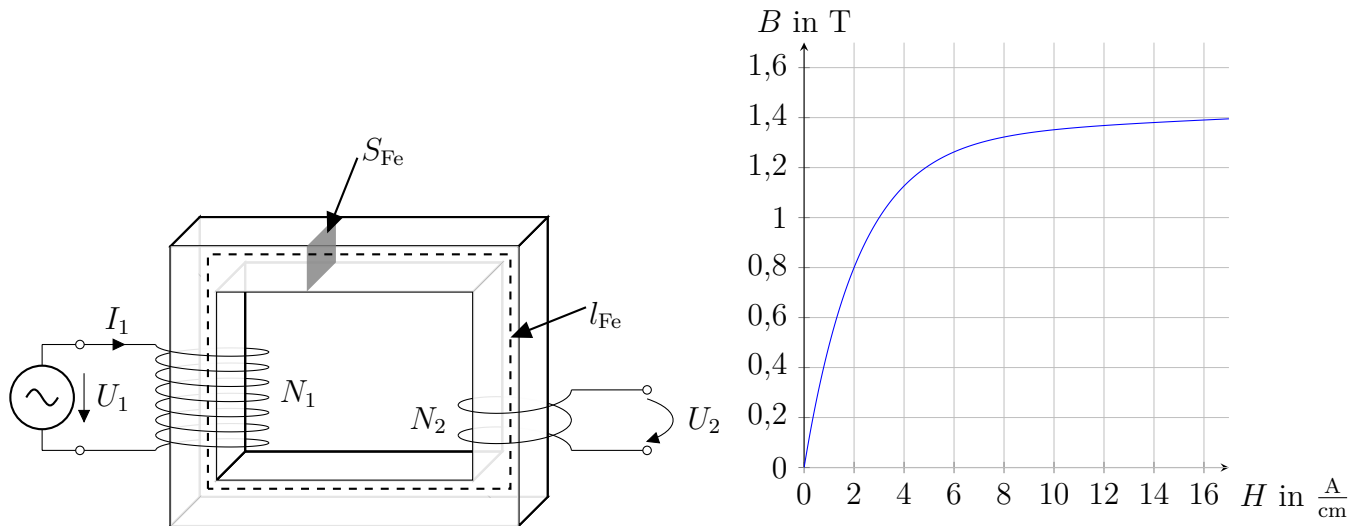
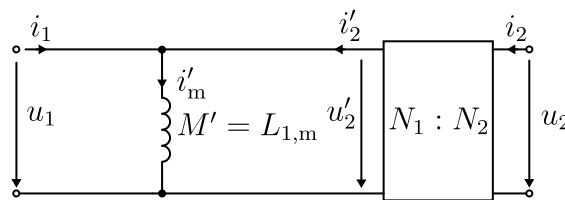

Figure 3.1: The left side shows a simplified sketch of the transformer given in the task. On the right hand side a magnetization curve is given.

Answer:

As described in the task, the windings are perfectly connected, which means, that no leakage flux occurs. In addition, the winding resistances and the iron losses of the transformer are neglected. This results in the equivalent circuit diagram shown in Sol.-Fig. 3.1.



Solution Figure 3.1: Equivalent circuit diagram without leakage flux and neglected winding and iron losses.

Therefore, the relationship between the voltage and flux linkage is given with:

$$u_1(t) = -\frac{d}{dt}\psi(t), \tag{3.15}$$

which is rearranged into the following form:

$$\psi = -\int u_1(t)dt = -\int \sqrt{2}U_1 \sin(\omega t)dt. \tag{3.16}$$

Due to the steady state, the integral is indefinite. This results in:

$$\psi = \frac{\sqrt{2}U_1}{\omega} \cos(\omega t). \tag{3.17}$$

This is simplified in the case of the maximum value of the flux linkage to:

$$\hat{\psi} = \frac{\sqrt{2}U_1}{\omega}. \quad (3.18)$$

The relationship between the flux linkage, the number of winding turns and flux is given with:

$$\psi = N_1\phi_1. \quad (3.19)$$

Hence, the number of turns is calculated with:

$$N_1 = \frac{\hat{\psi}}{\phi} = \frac{\frac{\sqrt{2}U_1}{\omega}}{\hat{B}S_{\text{Fe}}} = \frac{\frac{\sqrt{2} \cdot 230 \text{ V}}{2\pi \cdot 50 \text{ Hz}}}{0.8 \text{ T} \cdot 6 \cdot 10^{-4} \text{ m}} = 2157. \quad (3.20)$$

The turn ratio of the transformer is defined as follows

$$\ddot{u} = \frac{U_1}{U_2} = \frac{230 \text{ V}}{48 \text{ V}} = 4.79, \quad (3.21)$$

hence, the winding turns for the secondary winding are calculated by:

$$N_2 = \frac{N_1}{\ddot{u}} = \frac{2157}{4.79} = 451. \quad (3.22)$$

3.2 Which magnetization current I'_m consumed the transformer in the no-load operating mode? Assume that the iron losses are neglected.

Answer:

At no-load operation, the current through the secondary winding is assumed to zero ($i_2 = 0 \text{ A}$). Therefore, the electromotive force simplifies to:

$$\theta = H_{\text{Fe}}l_{\text{Fe}} = N_1i_1. \quad (3.23)$$

Due to the no-load operation, the current through the primary winding is equal to the magnetization current. In addition, the maximum flux density \hat{B} leads to the calculation of the peak magnetization current as:

$$\hat{i}_1 = \hat{i}'_{m,1} = \frac{\hat{H}_{\text{Fe}}l_{\text{Fe}}}{N_1} = \frac{2 \frac{\text{A}}{\text{cm}} \cdot 30 \text{ cm}}{2157} = 27.8 \text{ mA}. \quad (3.24)$$

The magnetic flux density B shows a linear behavior in the area between 0 T and 0.8 T. Therefore, the magnetization current is not distorted due to the magnetization and has a sinusoidal characteristic. Hence, the current is calculated as follows:

$$I'_m = \frac{\hat{i}'_{m,1}}{\sqrt{2}} = \frac{27.8 \text{ mA}}{\sqrt{2}} = 19.7 \text{ mA}. \quad (3.25)$$

3.3 Calculate the factor between the peak magnetization current $\hat{i}'_{m,2}$, when the applied voltage is risen from $U_1 = 230 \text{ V}$ to $U_1 = 400 \text{ V}$.

Answer:

With the rearranged equation (3.20), the maximum flux density is calculated by:

$$\hat{B} = \frac{\sqrt{2}U_1}{\omega S_{\text{Fe}}N_1} = \frac{\sqrt{2} \cdot 400 \text{ V}}{2\pi \cdot 50 \text{ Hz} \cdot 6 \cdot 10^{-4} \text{ m} \cdot 2157} = 1.39 \text{ T.} \quad (3.26)$$

The maximum flux density is used to determine the maximum field strength $\hat{H} = 16 \frac{\text{A}}{\text{cm}}$. Hence, the peak magnetization current results in:

$$\hat{i}'_{m,2} = \frac{\hat{H}_{\text{Fe}}l_{\text{Fe}}}{N_1} = \frac{16 \frac{\text{A}}{\text{cm}} \cdot 30 \text{ cm}}{2157} = 222.5 \text{ mA.} \quad (3.27)$$

Hence, the factor is calculated as:

$$\frac{\hat{i}'_{m,2}}{\hat{i}'_{m,1}} = \frac{222.5 \text{ mA}}{27.8 \text{ mA}} = 8. \quad (3.28)$$

Task 4: Parameter identification via no-load test

Given is a 50 Hz, 6 MVA single-phase transformer with $U_1 = 5 \text{ kV}$ and $U_2 = 100 \text{ kV}$. The effective area of the core is $S_{\text{Fe}} = 0.187 \text{ m}^2$ and a maximum flux density of $\hat{B} = 1.5 \text{ T}$. During the no-load operation, the primary voltage is $U_{1,o} = 5 \text{ kV}$ with a no-load electrical power $P_o = 8.8 \text{ kW}$ and the no-load current $I_o = 2.6 \text{ A}$.

4.1 Calculate the nominal currents and the transformer ratio.

Answer:

The transformer ratio is given as:

$$\ddot{u} = \frac{U_1}{U_2} = \frac{5 \text{ kV}}{100 \text{ kV}} = 0.05. \quad (3.29)$$

With the apparent power S of the transformer, the primary and secondary currents are calculated by:

$$\begin{aligned} I_1 &= \frac{S}{U_1} = \frac{6 \text{ MVA}}{5 \text{ kV}} = 1200 \text{ A,} \\ I_2 &= \frac{S}{U_2} = \frac{6 \text{ MVA}}{100 \text{ kV}} = 60 \text{ A.} \end{aligned} \quad (3.30)$$

4.2 Calculate the number of winding turns N_1 for the primary and N_2 for the secondary side.

Answer:

The number of winding turns for the primary side is calculated with:

$$N_1 = \frac{\hat{\psi}}{\phi} = \frac{\sqrt{2}U_1}{\omega \hat{B}S_{Fe}} = \frac{\sqrt{2} \cdot 5 \text{ kV}}{2\pi \cdot 50 \text{ Hz} \cdot 1.5 \text{ T} \cdot 0.187 \text{ m}^2} = 81. \quad (3.31)$$

The number of winding turns for the secondary side is calculated with the transformer ratio as follows:

$$N_2 = \frac{N_1}{\ddot{u}} = \frac{81}{0.05} = 1620. \quad (3.32)$$

4.3 Determine the iron losses and the apparent power S_o for no-load operation. Give the values for the magnetization current I'_m , the iron loss current I_c and the mutual inductance M' . Assume for the calculation that $R_1 \ll R_c$ and $L_{1,\sigma} \ll M'$. In addition, draw the equivalent circuit diagram with the given assumptions.

Answer:

The equivalent circuit diagram for the no-load operation with the iron loss resistance R_c is shown in Sol.-Fig. 3.2.

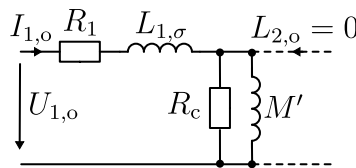

Solution Figure 3.2: Equivalent circuit diagram for the no-load test with the iron loss resistor R_c .

The no-load apparent power is calculated by

$$S_o = U_o I_o = 5 \text{ kV} \cdot 2.6 \text{ A} = 13 \text{ kVA}, \quad (3.33)$$

with the no-load voltage U_o and the no-load current I_o .

The equivalent iron loss resistance is determine as follows

$$R_c = \frac{U_{1,o}^2}{P_{1,o}} = \frac{(5 \text{ kV})^2}{8.8 \text{ kW}} = 2841 \ \Omega, \quad (3.34)$$

and, therefore, the corresponding current is calculated with:

$$I_c = \sqrt{\frac{P_{1,o}}{R_c}} = \sqrt{\frac{8.8 \text{ kW}}{2841 \ \Omega}} = 1.76 \text{ A}. \quad (3.35)$$

The power factor is determined as

$$\cos \varphi_o = \frac{P}{S} = \frac{8.8 \text{ kW}}{13 \text{ kVA}} = 0.68, \quad (3.36)$$

and the corresponding angle is $\varphi_o = 47.16^\circ$.

The following equation is used to calculate the mutual inductance

$$\omega_{el} M' \approx \frac{U_{1,o}}{I_{1,o} \sin(\varphi_o)}, \quad (3.37)$$

which is rearranged to:

$$M' = \frac{U_{1,o}}{I_{1,o} \sin(\varphi_o) \omega_{el}} = \frac{5 \text{ kV}}{2.6 \text{ A} \cdot \sin(47.16^\circ) \cdot 2\pi \cdot 50 \text{ Hz}} = 8.35 \text{ H}. \quad (3.38)$$

With the geometric addition the magnetization currents is calculated with:

$$I'_m = \sqrt{I_{1,o}^2 - I_c^2} = \sqrt{(2.6 \text{ A})^2 - (1.76 \text{ A})^2} = 1.91 \text{ A}. \quad (3.39)$$

Task 5: Inrush current

Given is a single-phase transformer in no-load operation (i.e., open circuit secondary side) which initial primary current is zero. At the time point $t = 0$, the voltage $u_n(t) = \hat{u}_n \sin(\omega t + \alpha)$ is applied. Remanence and iron losses are neglected. The self-inductance L_1 , resistance R_1 and the number of winding turns N_1 are given.

5.1 Calculate the inrush current trajectory $i_1(t)$ and the trajectory of the flux $\phi(t)$.

Answer:

The dynamic equation of the transformer current is given as follows:

$$\frac{d}{dt} \mathbf{i}(t) = \begin{bmatrix} -\frac{R_1}{\sigma L_1} & \frac{R_2 M}{\sigma L_1 L_2} \\ \frac{R_1 M}{\sigma L_1 L_2} & -\frac{R_2}{\sigma L_2} \end{bmatrix} \mathbf{i}(t) + \begin{bmatrix} \frac{1}{\sigma L_1} & -\frac{M}{\sigma L_1 L_2} \\ -\frac{M}{\sigma L_1 L_2} & \frac{1}{\sigma L_2} \end{bmatrix} \mathbf{u}(t). \quad (3.40)$$

Due to the no-load operation ($i_2 = 0 \text{ A}$) and the neglected leakage flux, the equation simplifies to:

$$\frac{d}{dt} i_1(t) = -\frac{R_1}{L_1} i_1(t) - \frac{1}{L_1} u_1(t). \quad (3.41)$$

The equation from above is rearranged to solve the ordinary differential equation. Therefore, the homogeneous part is on the left side and the perturbation part on the right side as given below

$$\frac{d}{dt} i_1(t) + \frac{1}{\tau} i_1(t) = \frac{1}{L_1} u_1(t), \quad (3.42)$$

with $\tau = \frac{L_1}{R_1}$.

First, the homogeneous part is separated, which results in:

$$\frac{d}{dt} i_1(t) + \frac{1}{\tau} i_1(t) = 0. \quad (3.43)$$

This homogeneous part is solved with the exponential approach, which is given with

$$i_1(t) = Ce^{-\frac{t}{\tau}}, \quad (3.44)$$

and the first derivative

$$\frac{d}{dt}i_1(t) = -\frac{C}{\tau}e^{-\frac{t}{\tau}}, \quad (3.45)$$

with an integration constant C .

Using (3.44) and (3.45) results in

$$\frac{R_1}{L_1}Ce^{-\frac{t}{\tau}} - \frac{C}{\tau}e^{-\frac{t}{\tau}} = 0, \quad (3.46)$$

which is rearranged as follows:

$$Ce^{-\frac{t}{\tau}} \left(\frac{R_1}{L_1} - \frac{1}{\tau} \right) = 0. \quad (3.47)$$

Therefore, the homogeneous solution is given as:

$$i_{1,h}(t) = Ce^{-\frac{t}{\tau}}. \quad (3.48)$$

In the second step, the perturbation solution is determined. Therefore, the comparison of coefficients ansatz is used. The voltage is given in the task with

$$u_n = \hat{u}_n \sin(\omega t + \alpha), \quad (3.49)$$

which leads to:

$$\sin(\omega t + \alpha) = \cos(\omega t) \sin(\alpha) + \sin(\omega t) \cos(\alpha). \quad (3.50)$$

The expression in (3.50) is separated in two parts which are later combined again (superposition principle of linear systems). The approach for the first case is given by:

$$\frac{d}{dt}i(t) + \frac{1}{\tau}i(t) = k \sin(\alpha) \cos(\omega t), \quad (3.51)$$

with a new parameter $k = \frac{\hat{u}_n}{L_1}$, derived from (3.42).

The general approach is given with

$$i_{1,s}(t) = a \cos(\omega t) + b \sin(\omega t), \quad (3.52)$$

with the two parameter a and b . The first derivative is determined as:

$$\frac{d}{dt}i_{1,s}(t) = -a\omega \sin(\omega t) + b\omega \cos(\omega t). \quad (3.53)$$

With (3.52) and (3.53) in (3.42) the equation is determined:

$$-a\omega \sin(\omega t) + b\omega \cos(\omega t) + \frac{1}{\tau} [a \cos(\omega t) + b \sin(\omega t)] = k \sin(\alpha) \cos(\omega t). \quad (3.54)$$

The following equation is obtained by reshaping

$$\sin(\omega t) \left[-a\omega + \frac{1}{\tau}b \right] + \cos(\omega t) \left[b\omega + \frac{1}{\tau}a - k \sin(\omega t) \right] = 0, \quad (3.55)$$

and by dividing through $\cos(\omega t)$ results in:

$$\tan(\omega t) \left[-a\omega + \frac{1}{\tau}b \right] + \left[b\omega + \frac{1}{\tau}a - k \sin(\omega t) \right] = 0. \quad (3.56)$$

To fulfill the equation, the expressions between the large brackets must be zero. The first expression is given with:

$$\begin{aligned} -a\omega + \frac{1}{\tau}b &= 0, \\ b &= a\omega\tau. \end{aligned} \quad (3.57)$$

The second expression is defined with:

$$b\omega + \frac{1}{\tau}a - k \sin(\alpha) = 0. \quad (3.58)$$

With b from (3.57) results in

$$\begin{aligned} a\omega^2\tau + \frac{1}{\tau}a - k \sin(\alpha) &= 0, \\ a \left[\omega^2\tau + \frac{1}{\tau} \right] &= k \sin(\alpha), \end{aligned} \quad (3.59)$$

which is reshaped to:

$$a = \frac{k \sin(\alpha)}{\omega^2\tau + \frac{1}{\tau}}. \quad (3.60)$$

Therefore, with the two calculated coefficients, the solution for the first approach is:

$$i_{1,s}(t) = \frac{k \sin(\alpha)}{\omega^2\tau + \frac{1}{\tau}} [\cos(\omega t) + \omega\tau \sin(\omega t)]. \quad (3.61)$$

The second case is given with $\frac{d}{dt}i(t) + \frac{1}{\tau}i(t) = k \cos(\alpha) \sin(\omega t)$. To do this, the steps already carried out in the first approach are repeated. The starting point is given as

$$i_{2,s}(t) = a \cos(\omega t) + b \sin(\omega t), \quad (3.62)$$

and, therefore, the first derivative:

$$\frac{d}{dt}i_{2,s}(t) = -a\omega \sin(\omega t) + b\omega \cos(\omega t). \quad (3.63)$$

The comparison of coefficients and reshaping leads to:

$$\begin{aligned} -a\omega \sin(\omega t) + b\omega \cos(\omega t) &= \frac{1}{\tau} [a \cos(\omega t) + b \sin(\omega t)] = k \sin(\omega t), \\ \sin(\omega t) \left[-a\omega + \frac{1}{\tau}b - k \cos(\alpha) \right] &+ \cos(\omega t) \left[b\omega + \frac{1}{\tau}a \right] = 0. \end{aligned} \quad (3.64)$$

To fulfill the equation, the expressions between the large brackets must be zero. The first expression is given with:

$$\begin{aligned} b\omega + \frac{1}{\tau}a &= 0, \\ a &= \omega b\tau. \end{aligned} \quad (3.65)$$

The second expression is defined with:

$$\begin{aligned} -a\omega + \frac{1}{\tau}b - k \cos(\alpha) &= 0, \\ \omega^2 b\tau + \frac{1}{\tau}b - k \cos(\alpha) &= 0, \\ b &= \frac{k \cos(\alpha)}{\omega^2\tau + \frac{1}{\tau}}. \end{aligned} \quad (3.66)$$

This result is used to solve parameter a from (3.65) as follows:

$$a = -\omega b\tau = -\frac{\omega\tau k \cos(\alpha)}{\omega^2\tau + \frac{1}{\tau}}. \quad (3.67)$$

Therefore, the solution for the second case of the perturbation part is defined as

$$i_{s,2}(t) = \frac{k \cos(\alpha)}{\omega^2\tau + \frac{1}{\tau}} [-\omega\tau \cos(\omega t) + \sin(\omega t)], \quad (3.68)$$

and, this leads to the solution of the perturbation part by:

$$i_{1,s}(t) = \frac{k}{\omega^2\tau + \frac{1}{\tau}} [\sin(\alpha) [\cos(\omega t) + \omega\tau \sin(\omega t)] + \cos(\alpha) [-\omega\tau \cos(\omega t) + \sin(\omega t)]]. \quad (3.69)$$

The total solution is given with:

$$i_1(t) = i_{1,h}(t) + i_{1,s}(t). \quad (3.70)$$

Next, the integration constant C from the homogeneous solution is determined. To perform this, the initial conditions are used, which are defined in the task description. Therefore, the current is defined as:

$$i_1(0) = 0. \quad (3.71)$$

The second initial condition is the results of applying (3.71) to the differential equation, that is:

$$\frac{d}{dt}i_1(0) = \frac{1}{L_1}u(0) = \frac{1}{L_1}\hat{u} \sin(\alpha). \quad (3.72)$$

Apply the initial conditions to the total solution results in

$$i(0) = C + \frac{k}{\omega^2\tau + \frac{1}{\tau}} [\sin(\alpha) - \omega\tau \cos(\alpha)] = 0, \quad (3.73)$$

which is rearranged to:

$$C = \frac{k}{\omega^2\tau + \frac{1}{\tau}} [-\sin(\alpha) + \omega\tau \cos(\alpha)]. \quad (3.74)$$

Therefore, the total solution is given with:

$$\begin{aligned} i_1(t) = & \frac{k}{\omega^2\tau + \frac{1}{\tau}} [-\sin(\alpha) + \omega\tau \cos(\alpha)] e^{-\frac{t}{\tau}} \\ & + \frac{k}{\omega^2\tau + \frac{1}{\tau}} [\sin(\alpha) [\cos(\omega t) + \omega\tau \sin(\omega t)] + \cos(\alpha) [-\omega\tau \cos(\omega t) + \sin(\omega t)]]. \end{aligned} \quad (3.75)$$

The trajectory of the flux is defined as

$$\phi(t) = L_1 i(t), \quad (3.76)$$

and, therefore, directly given with the current trajectory.

5.2 Assume that $R_1 \ll \omega L_1$. Discuss the result for $i_1(t)$, when the voltage is applied at zero crossing with an angle $\alpha = 0$ and for an angle of $\alpha = \frac{\pi}{2}$.

Answer:

First, the trajectory for $\alpha = 0$ is determined. Therefore, (3.75) results in:

$$i_1(t) = \frac{k}{\omega^2\tau + \frac{1}{\tau}} [\omega\tau e^{-\frac{t}{\tau}} - \omega\tau \cos(\omega t) + \sin(\omega t)]. \quad (3.77)$$

With the assumptions given in the task, $R_1 \ll L_1\omega$ results into $\omega\tau \gg 1$.

Hence, the equation simplifies to

$$\begin{aligned} i_1(t) = & \frac{k}{\omega^2\tau + \frac{1}{\tau}} \omega\tau [e^{-\frac{t}{\tau}} - \cos(\omega t)], \\ = & \frac{\hat{u}}{L_1} \frac{1}{\omega} [e^{-\frac{t}{\tau}} - \cos(\omega t)], \end{aligned} \quad (3.78)$$

which is used to calculate the current trajectory. As it can be seen, the equation contains an

exponential part. To determine the steady-state current trajectory, the equation is reshaped into:

$$\begin{aligned} i_1(t) &= \frac{\hat{u}}{L_1\omega} e^{-\frac{t}{\tau}} - \frac{\hat{u}}{L_1\omega} \cos(\omega t), \\ &= \frac{\hat{u}}{L_1\omega} e^{-\frac{t}{\tau}} + \frac{\hat{u}}{L_1} \int \sin(\omega t) dt. \end{aligned} \quad (3.79)$$

With the input voltage $u(t) = \hat{u} \sin(\omega t + \alpha)$, the equation simplifies to:

$$i_1(t) = \frac{\hat{U}}{L_1\omega} e^{-\frac{t}{\tau}} + \frac{1}{L_1} \int u(t) dt. \quad (3.80)$$

Assumed, that in the steady state $\tau \rightarrow \infty$, only the second part of the equation remains. Therefore, the current trajectory is given with:

$$i_1(t) = \frac{1}{L_1} \int u(t) dt. \quad (3.81)$$

Next, the trajectory for $\alpha = \frac{\pi}{2}$ is determined. Therefore, the equation (3.75) is solved as follows:

$$\begin{aligned} i_1(t) &= \frac{k}{\omega^2\tau + \frac{1}{\tau}} [\cos(\omega t) + \omega\tau \sin(\omega t)], \\ &= \frac{k}{\omega^2\tau + \frac{1}{\tau}} [\omega\tau \sin(\omega t)], \\ &= \frac{1}{L_1} \hat{U} \frac{1}{\omega} \sin(\omega t), \\ &= \frac{\hat{U}}{L_1\omega} \sin(\omega t). \end{aligned} \quad (3.82)$$

In Sol.-Fig. 3.3 the two calculated current trajectories are visualized. They result from the applied voltage with the additional angle α . In this example is the peak current value during the transient process approximately double than in the steady state, which can trigger the overcurrent protection. Therefore, the magnetization current should be kept low and the overcurrent protection must be able to handle the inrush current.

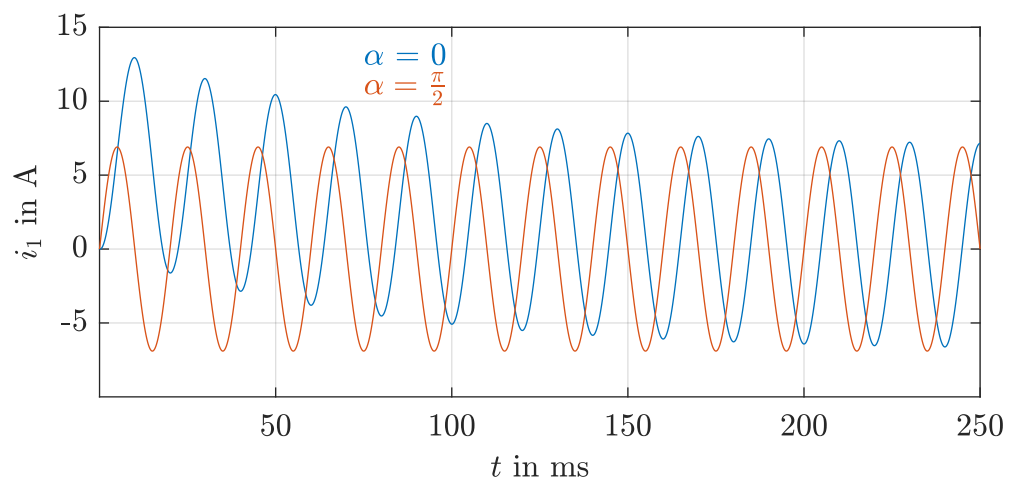

Solution Figure 3.3: Current of the transformer, when the voltage is applied at two different angles for α .

Exercise 04: Fourier analysis of rotating fields

Acknowledgement: The following exercise is adapted from “Geregelte Drehstromantriebe / Controlled AC Drives” by J. Böcker, Paderborn University, 2021 and “Elektrische Maschinen und Antriebe Übungsbuch: Aufgaben mit Lösungsweg” by A. Binder, Springer, 2017

Task 1: Fourier analysis of a field distribution of a three-phase winding

The winding of a three-phase and four-pole machine is described with the following parameters. The number of notches is given with $q = 2$ and the winding chording is $y/\rho_p = 5/6$. The number of windings per coil is given with $N_c = 5$ with $a = 1$. The air gap is given with $\delta = 1$ mm and the inner stator diameter is $d_s = 80$ mm. The phase current root mean square value is given with $I_s = 30$ A.

1.1 Calculate the number of slots per pole pair. In addition, determine the pole pitch ρ_p as an angular information and calculate the pole pitch τ_p as a distance in m. Furthermore, determine the number of conductors per phase.

Answer:

The number of slots is calculated with

$$Q = q2pm = 2 \cdot 2 \cdot 2 \cdot 3 = 24, \quad (4.1)$$

where p is the number of pole pairs and m is the number of phases. Therefore, the number of slots per pole pair is given with:

$$\frac{Q}{p} = \frac{24}{2} = 12. \quad (4.2)$$

The pole pitch as an angular information is calculated with

$$\rho_p = \frac{\pi}{p} = \frac{\pi}{2}, \quad (4.3)$$

and in comparison, the pole pitch as a distance information is determined as:

$$\tau_p = \frac{d_s \pi}{2p} = \frac{80 \text{ mm} \cdot \pi}{2 \cdot 2} = 62.8 \text{ mm}. \quad (4.4)$$

The conductors per phase are calculated by:

$$N_a = \frac{2pqN_c}{a} = \frac{2 \cdot 2 \cdot 2 \cdot 5}{1} = 40. \quad (4.5)$$

1.2 Calculate the amplitude of the flux density fundamental in the air gap assuming an ideal homogenous and block-shaped flux distribution along the stator circumference.

Answer:

The maximum flux density is given with:

$$\hat{B} = \frac{\mu_0 N \hat{i}}{2\delta} = \frac{4\pi \cdot 10^{-7} \frac{\text{Vs/m}}{\text{A}} \cdot 40 \cdot (30 \cdot \sqrt{2}) \text{ A}}{2 \cdot 0.001 \text{ m}} = 1.07 \text{ Vs.} \quad (4.6)$$

The general form to calculate the flux density for phase a of a harmonic order is defined by

$$\hat{B}_a^{(k)}(t) = \frac{4}{\pi} \hat{B} \cos(\omega t) \frac{1}{k} \xi_{d,k} \xi_{p,k}, \quad (4.7)$$

with $\xi_{d,k}$ is the distribution and $\xi_{p,k}$ is the pitch factor. Hence, for the fundamental wave is $k = 1$, which leads to

$$\xi_{d,1} = \frac{\sin\left(\frac{1\pi}{2m}\right)}{q \sin\left(\frac{1\pi}{2mq}\right)} = \frac{\sin\left(\frac{1\pi}{2 \cdot 3}\right)}{2 \cdot \sin\left(\frac{1\pi}{2 \cdot 3 \cdot 2}\right)} = 0.966, \quad (4.8)$$

and,

$$\xi_{p,1} = \sin\left(1 \cdot \frac{\pi}{2} \frac{y}{\rho_p}\right) = \sin\left(1 \cdot \frac{\pi}{2} \cdot \frac{5}{6}\right) = 0.966. \quad (4.9)$$

Finally, (4.7) is multiplied by a factor of $\frac{3}{2}$ to calculate the amplitude of the fundamental wave of the three phases acting on the air gap flux. This leads to:

$$\hat{B}^{(1)} = \frac{3}{2} \cdot \frac{4}{\pi} \cdot 1.07 \text{ Vs} \cdot \frac{1}{1} \cdot 0.966 \cdot 0.966 = 1.27 \text{ Vs.} \quad (4.10)$$

1.3 Determine the amplitudes of the resulting flux density for the fundamental wave and the following six harmonic orders. Give the results as relative fractions to the amplitude of the fundamental wave. In addition, calculate the distribution, pitch and winding factor for the given harmonics and the fundamental wave.

Answer:

The flux density for the harmonic orders is calculated with (4.10). The pitch factors are determined with (4.9) and the distribution factors with (4.8). The winding factor is given with:

$$\xi_{w,k} = \xi_{d,k} \xi_{p,k}. \quad (4.11)$$

For the calculation up to the 19th harmonic, a short Python script is written. The results are visualized in Sol.-Tab. 4.1.

1.4 Sketch the flux density of the fundamental wave in the air gap of phase a as a function of the electrical stator circumference ϑ_{el} . Assume $i_a(t) = I_s \cdot \sqrt{2}$, i.e., the phase a is at its current peak. In addition, draw the flux density of the 11th harmonic.

Answer:

The calculation is performed with (4.7) in a separate Python script. The resulting trajectories are shown in Sol.-Fig. 4.1.

Solution Table 4.1: Distribution, pitch, and winding factors as well as relative harmonic flux density amplitudes.

k	$\frac{\hat{B}^{(k)}}{\hat{B}^{(1)}}$ in %	$\xi_{p,k}$	$\xi_{d,k}$	$\xi_{w,k}$
1	100	0.966	0.966	0.966
5	1.4	0.259	0.259	0.067
7	1.0	0.259	0.259	0.067
11	9.1	0.966	0.966	0.933
13	7.7	0.966	0.966	0.933
17	0.4	0.259	0.259	0.067
19	0.38	0.259	0.259	0.067

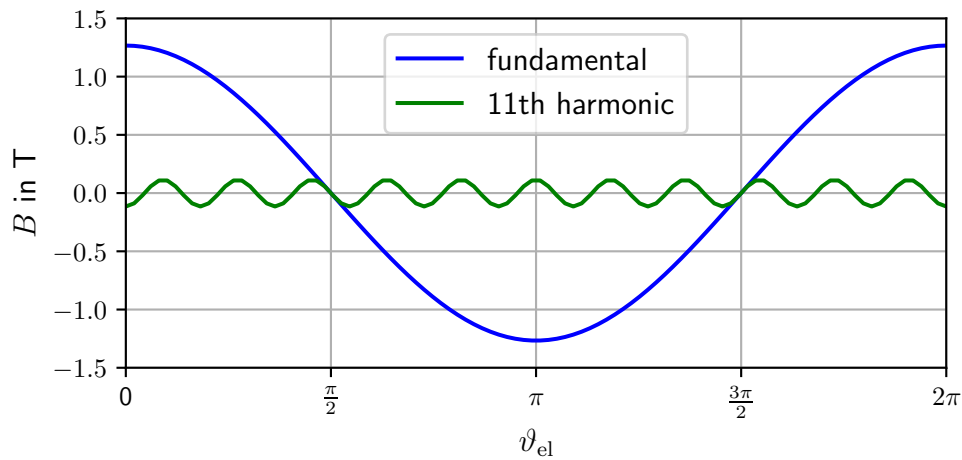

Solution Figure 4.1: Visualization of the flux density of the fundamental wave and the 11th harmonic of phase a.

Task 2: Distributed windings

Consider a 4-pole three-phase motor with 15 stator slots. A simplified sketch of this motor with the winding scheme of phase a is shown in Fig. 4.1.

2.1 Determine the pole pitch ρ_p and the number of notches. Is it an integral-slot or a fractional-slot winding?

Answer:

The number of slots are shown in the figure, which leads to $Q = 15$. Furthermore, the number of phases is given in the task, that is $m = 3$.

Hence, the pole pitch is calculated as:

$$\rho_p = \frac{2\pi}{2p} = \frac{\pi}{2}. \quad (4.12)$$

The number of notches is defined with:

$$q = \frac{Q}{2pm} = \frac{15}{2 \cdot 2 \cdot 3} = \frac{15}{12} = \frac{5}{4}. \quad (4.13)$$

Since the number of notches per pole and phase is not an integer, it is a fractional slot winding. The

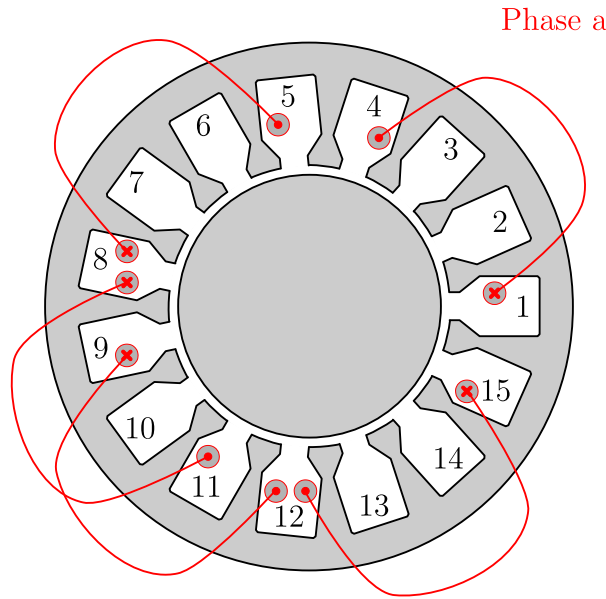

Figure 4.1: Simplified sketch of a distributed winding scheme. Only phase a is shown.

coil width y is three stator slots, which leads to the angular coil width:

$$w = \frac{2\pi}{Q} m = \frac{2\pi}{15} \cdot 3 = \frac{2\pi}{5}. \quad (4.14)$$

Therefore, the chording factor is determined with:

$$s = \frac{w}{\tau_p} = \frac{6\pi \cdot 2}{15\pi} = \frac{12}{15}. \quad (4.15)$$

2.2 Complete the winding scheme of the given machine in Tab. 4.1 for the phases b and c. Sketch the resulting winding scheme into Fig. 4.1.

Table 4.1: Winding scheme of the distributed winding from Fig. 4.1.

Coil nr.	Phase a		Phase b		Phase c	
	In	Out	In	Out	In	Out
1	1	4				
2	8	5				
3	8	11				
4	9	12				
5	15	12				

Answer:

In the task only phase a of the winding scheme is given. However, to complete the winding scheme,

phase b must have an electrical phase shift of 120° and phase c of 240° respectively. This leads to

$$n_b p \frac{360^\circ}{Q} = 120^\circ \text{ mod } 360^\circ, \quad (4.16)$$

where n_b is the displacement in slots. This expression is rewritten into

$$n_b p \frac{360^\circ}{Q} = 120^\circ + k360^\circ, \quad (4.17)$$

and also for phase c:

$$n_c p \frac{360^\circ}{Q} = 240^\circ + k360^\circ. \quad (4.18)$$

Now, an integral solution must be found for (4.17) and (4.18) to determine the winding scheme. This is done with trial and error, the first assumption is $n_b = 10, k = 1$, which results in

$$\begin{aligned} 10 \cdot 2 \cdot \frac{360^\circ}{15} &= 120^\circ + 360^\circ, \\ 480^\circ &= 480^\circ, \end{aligned} \quad (4.19)$$

therefore, the requirement is fulfilled. For phase c the assumption is given with $n_c = 5, k = 1$ into (4.18)

$$\begin{aligned} 5 \cdot 2 \cdot \frac{360^\circ}{15} &= 240^\circ + k360^\circ, \\ 240^\circ &= 240^\circ, \end{aligned} \quad (4.20)$$

which fulfills the requirement too. With the calculated phase shift and the knowledge of the coil width of three slots from the figure, the winding scheme is completed. In Sol.-Tab. 4.2 the inputs and outputs of each winding are given.

Solution Table 4.2: Solution of the distributed winding scheme.

Coil nr.	Phase a		Phase b		Phase c	
	In	Out	In	Out	In	Out
1	1	4	11	14	6	9
2	8	5	3	15	13	10
3	8	11	3	6	13	1
4	9	12	4	7	14	2
5	15	12	10	7	5	2

The sketch of the distributed winding scheme is visualized in Sol.-Fig. 4.2.

2.3 How many layers are there in this winding scheme?

Answer:

The winding diagram has 2 winding layers, due to the two conductors per slot.

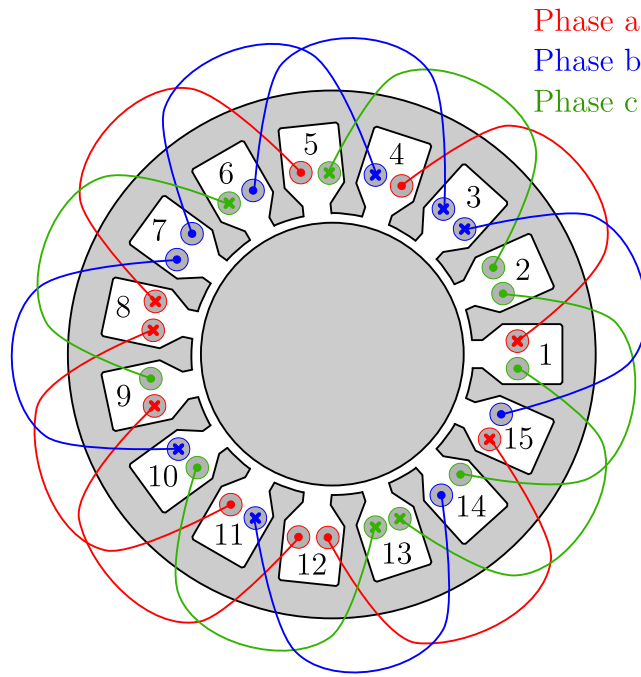

Solution Figure 4.2: Solution of the distributed winding.

2.4 Calculate the complex winding factors $\underline{\xi}_{a,k}$ for the fundamental as well as for the 5th and 7th harmonic.

Answer:

The complex winding factor is defined by

$$\underline{\xi}_{a,k} = \frac{1}{jN_a} \sum_{i=1}^Q N_{a,i} e^{jk\vartheta_{el,a,i}}, \quad (4.21)$$

with

$$N_a = \sum_{i=1}^Q |N_{a,i}|, \quad (4.22)$$

and the electrical angle:

$$\vartheta_{el,a,i} = \vartheta_{a,i} \cdot p. \quad (4.23)$$

The mechanical angles are calculated with

$$\vartheta_{a,i} = (i - 1) \frac{360^\circ}{Q} = (i - 1) \cdot \frac{360^\circ}{15} = (i - 1) \cdot 24^\circ, \quad (4.24)$$

where i represents the number of the stator slot. Therefore, the mechanical angles are given in Sol.-Tab. 4.3.

To calculate the winding factors, the total number of turns of the respective phase N_a is determined for each stator slot. A negative sign indicates, that the winding turn is oriented towards the negative z -axis. When no conductor is in a slot, $N_{a,i} = 0$. The result is shown in Sol.-Tab. 4.4.

For the fundamental wave $k = 1$ applies and, therefore, with (4.21), the winding factor of the

Solution Table 4.3: Mechanical angles of the distributed winding from Fig. 4.1.

$\vartheta_{a,1} = 0^\circ$	$\vartheta_{a,9} = 192^\circ$
$\vartheta_{a,4} = 72^\circ$	$\vartheta_{a,11} = 240^\circ$
$\vartheta_{a,5} = 96^\circ$	$\vartheta_{a,12} = 264^\circ$
$\vartheta_{a,8} = 168^\circ$	$\vartheta_{a,15} = 336^\circ$

Solution Table 4.4: Winding turns of phase a of the distributed winding.

$N_{a1} = -1$	$N_{a4} = 1$	$N_{a5} = 1$
$N_{a8} = -2$	$N_{a9} = -1$	$N_{a11} = 1$
$N_{a12} = 2$	$N_{a15} = -1$	

fundamental wave calculates as follows

$$\begin{aligned} \underline{\xi}_{a,1} = \frac{1}{10j} \cdot [& -e^{j \cdot 1 \cdot 2 \cdot 0^\circ} + e^{j \cdot 1 \cdot 2 \cdot 72^\circ} + e^{j \cdot 1 \cdot 2 \cdot 92^\circ} - 2e^{j \cdot 1 \cdot 2 \cdot 168^\circ} - e^{j \cdot 1 \cdot 2 \cdot 192^\circ} + e^{j \cdot 1 \cdot 2 \cdot 240^\circ} \\ & + 2e^{j \cdot 1 \cdot 2 \cdot 264^\circ} - e^{j \cdot 1 \cdot 2 \cdot 336^\circ}] = 0.2812 + 0.8653j, \end{aligned} \quad (4.25)$$

with the corresponding absolute value:

$$|\underline{\xi}_{a,1}| = 0.9099. \quad (4.26)$$

For the 5th harmonic is $k = 5$, which results in

$$\begin{aligned} \underline{\xi}_{a,5} = \frac{1}{10j} \cdot [& -e^{j \cdot 5 \cdot 2 \cdot 0^\circ} + e^{j \cdot 5 \cdot 2 \cdot 72^\circ} + e^{j \cdot 5 \cdot 2 \cdot 92^\circ} - 2e^{j \cdot 5 \cdot 2 \cdot 168^\circ} - e^{j \cdot 5 \cdot 2 \cdot 192^\circ} + e^{j \cdot 5 \cdot 2 \cdot 240^\circ} \\ & + 2e^{j \cdot 5 \cdot 2 \cdot 264^\circ} - e^{j \cdot 5 \cdot 2 \cdot 336^\circ}] = 0, \end{aligned} \quad (4.27)$$

with the corresponding absolute value:

$$|\underline{\xi}_{a,5}| = 0. \quad (4.28)$$

The complex winding factor for the 7th harmonic results by

$$\begin{aligned} \underline{\xi}_{a,7} = \frac{1}{10j} \cdot [& -e^{j \cdot 7 \cdot 2 \cdot 0^\circ} + e^{j \cdot 7 \cdot 2 \cdot 72^\circ} + e^{j \cdot 7 \cdot 2 \cdot 92^\circ} - 2e^{j \cdot 7 \cdot 2 \cdot 168^\circ} - e^{j \cdot 7 \cdot 2 \cdot 192^\circ} + e^{j \cdot 7 \cdot 2 \cdot 240^\circ} \\ & + 2e^{j \cdot 7 \cdot 2 \cdot 264^\circ} - e^{j \cdot 7 \cdot 2 \cdot 336^\circ}] = 0.0711 - 0.0516j, \end{aligned} \quad (4.29)$$

with the corresponding absolute value:

$$|\underline{\xi}_{a,7}| = 0.087. \quad (4.30)$$

2.5 Assume a block-shaped distribution of the flux density with a maximal value of $\hat{B} = 1$ T and a number of winding turns $N'_a = 30$ (i.e., there are more turns per coil as indicated within Fig. 4.1). The axial length of the machine is $l = 0.35$ m and the diameter is $d_s = 0.10$ m. The machine

rotates with a mechanical speed of $n = 250 \frac{1}{\text{min}}$. Calculate the induced voltage of phase a for the fundamental wave as well as of the 5th and 7th harmonics.

Answer:

The Fourier coefficient of the flux density is given with

$$B(\vartheta_{\text{el}}, t) = \frac{6}{\pi p} \hat{B} \sum_k \frac{1}{k} \sin\left(\frac{k\pi}{2}\right) \cos(\omega t - k\vartheta_{\text{el}}), \quad (4.31)$$

and for the fundamental wave:

$$B^{(1)}(\vartheta_{\text{el}}, t) = \frac{6}{\pi p} \hat{B} \sin\left(\frac{\pi}{2}\right) \cos(\omega t - \vartheta_{\text{el}}). \quad (4.32)$$

The flux linkage of phase a is calculated as

$$\phi_{a,k}(t) = l \frac{d_s}{2} |\xi_{a,k}| \int_{-\frac{\pi}{2}}^{\frac{\pi}{2}} B(\vartheta_{\text{el}}, t) d\vartheta_{\text{el}}, \quad (4.33)$$

with the complex winding factor to cover the winding distribution inside the stator. Hence, the fundamental wave calculates as follows:

$$\begin{aligned} \phi_{a,1}(t) &= l \frac{d_s}{2} |\xi_{a,1}| \frac{6}{\pi p} \hat{B} \sin\left(\frac{\pi}{2}\right) \int_{-\frac{\pi}{2}}^{\frac{\pi}{2}} \cos(\omega t - \vartheta_{\text{el}}) d\vartheta_{\text{el}} \\ &= l d_s |\xi_{a,1}| \frac{3}{\pi p} \hat{B} \int_{-\frac{\pi}{2}}^{\frac{\pi}{2}} \cos(\omega t) \cos(\vartheta_{\text{el}}) + \sin(\omega t) \sin(\vartheta_{\text{el}}) d\vartheta_{\text{el}} \\ &= l d_s |\xi_{a,1}| \frac{3}{\pi p} \hat{B} \left[\cos(\omega t) \int_{-\frac{\pi}{2}}^{\frac{\pi}{2}} \cos(\vartheta_{\text{el}}) d\vartheta_{\text{el}} + \sin(\omega t) \int_{-\frac{\pi}{2}}^{\frac{\pi}{2}} \sin(\vartheta_{\text{el}}) d\vartheta_{\text{el}} \right] \\ &= l d_s |\xi_{a,1}| \frac{3}{\pi p} \hat{B} \left[\cos(\omega t) \left[\sin(\vartheta_{\text{el}}) \right]_{-\frac{\pi}{2}}^{\frac{\pi}{2}} + \sin(\omega t) \left[-\cos(\vartheta_{\text{el}}) \right]_{-\frac{\pi}{2}}^{\frac{\pi}{2}} \right] \\ &= l d_s |\xi_{a,1}| \frac{3}{\pi p} \hat{B} [2 \cos(\omega t)] \\ &= l d_s |\xi_{a,1}| \frac{6}{\pi p} \hat{B} \cos(\omega t). \end{aligned} \quad (4.34)$$

Taking into account also the number of winding turns N'_a , the flux linkage of phase a is given with

$$\psi_{a,k}(t) = N'_a \phi_{a,k}(t), \quad (4.35)$$

which results for the fundamental wave into:

$$\begin{aligned} \psi_{a,1}(t) &= N'_a \phi_{a,1}(t) = N'_a l d_s |\xi_{a,1}| \frac{6}{\pi p} \hat{B} \cos(\omega t) \\ &= 30 \cdot 0.35 \text{ m} \cdot 0.10 \text{ m} \cdot \frac{6}{2\pi} \cdot 1 \text{ T} \cos(\omega t) \cdot 0.9099 \\ &= 0.9123 \text{ Vs} \cdot \cos(\omega t). \end{aligned} \quad (4.36)$$

The equation for the induced voltage of the fundamental wave is given with:

$$\begin{aligned}
 u_{\text{ind},a,1}(t) &= -\frac{d}{dt}\psi_{a,1} \\
 &= -\frac{d}{dt}0.9123 \text{ Vs} \cdot \cos(\omega t) \\
 &= 0.9123 \text{ Vs} \cdot \sin(\omega t)\omega \\
 &= 0.9123 \text{ Vs} \cdot \sin(\omega t) \cdot 2\pi \cdot 2 \cdot \frac{250}{60} \frac{1}{\text{s}} \\
 &= 47.78 \text{ V} \cdot \sin(\omega t).
 \end{aligned} \tag{4.37}$$

The flux linkage of the 5th harmonic is determined with (4.33), which results into

$$\phi_{a,5} = 0, \tag{4.38}$$

due to $|\xi_{a,5}| = 0$. Therefore, the induced voltage results by:

$$u_{\text{ind},a,5} = 0. \tag{4.39}$$

With (4.33) the flux linkage for the 7th harmonic is calculated by:

$$\begin{aligned}
 \phi_{a,7}(t) &= l \frac{d_s}{2} |\xi_{a,7}| \frac{6}{\pi p} \hat{B} \frac{1}{7} \sin\left(\frac{7\pi}{2}\right) \int_{-\frac{\pi}{2}}^{\frac{\pi}{2}} \cos(\omega t - 7\vartheta_{\text{el}}) d\vartheta_{\text{el}} \\
 &\vdots \\
 &= l \frac{d_s}{2} |\xi_{a,7}| \frac{6}{\pi p} \hat{B} \frac{1}{7} \cos(\omega t).
 \end{aligned} \tag{4.40}$$

The resulting flux linkage is calculated by taking into account the number of winding turns as

$$\begin{aligned}
 \psi_{a,7} &= N'_a \phi_{a,7}(t) = N'_a l \frac{d_s}{2} |\xi_{a,7}| \frac{6}{\pi p} \hat{B} \frac{1}{7} \cos(\omega t) \\
 &= 30 \cdot 0.35 \text{ m} \cdot \frac{10}{2} \text{ m} \cdot \frac{6}{2\pi} \cdot 1 \text{ T} \cdot \frac{1}{7} \cdot \cos(\omega t) \cdot 0.087 \\
 &= 0.0126 \text{ Vs} \cdot \cos(\omega t),
 \end{aligned} \tag{4.41}$$

therefore, the induced voltage is given with:

$$\begin{aligned}
 u_{\text{ind},a,7}(t) &= -\frac{d}{dt}\psi_{a,7} \\
 &= 0.0126 \text{ Vs} \cdot \sin(\omega t)\omega \\
 &= 0.0126 \text{ Vs} \cdot \sin(\omega t) \cdot 2\pi \cdot 2 \cdot \frac{250}{60} \frac{1}{\text{s}} \\
 &= 0.66 \text{ V} \cdot \sin(\omega t).
 \end{aligned} \tag{4.42}$$

2.6 Write a Python script to calculate the complex winding factor $\xi_{\Sigma a,k}$ up to various harmonics.

Answer:

The Python script is separately available, therefore, only the solution is presented in Tab 4.5.

Solution Table 4.5: Complex winding factor $\underline{\xi}_{a,k}$ up to the 12th harmonic order.

$\underline{\xi}_{a,1} = 0.2812+0.8653j$	$\underline{\xi}_{a,2} = -0.0486+0.0353j$	$\underline{\xi}_{a,3} = 0.3078+0.2236j$
$\underline{\xi}_{a,4} = 0.0322-0.099j$	$\underline{\xi}_{a,5} = 0$	$\underline{\xi}_{a,6} = -0.0727-0.2236j$
$\underline{\xi}_{a,7} = 0.0711-0.0516j$	$\underline{\xi}_{a,8} = -0.0711-0.0516j$	$\underline{\xi}_{a,9} = 0.0727-0.2236j$
$\underline{\xi}_{a,10} = 0$	$\underline{\xi}_{a,11} = -0.0322-0.099j$	$\underline{\xi}_{a,12} = -0.3078+0.2236j$

Task 3: Concentrated windings

Consider the shown 10-pole 3-phase motor with 12 stator slots in Fig. 4.2. The winding scheme of phase a is shown in the figure.

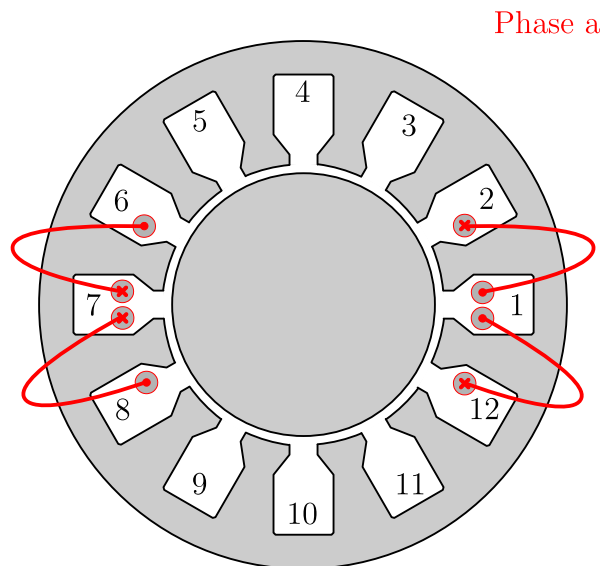

Figure 4.2: Simplified sketch of a concentrated winding. Only phase a is shown.

3.1 Determine the pole pitch and und the number of notches. Is it an integral-slot or a fractional-slot winding?

Answer:

The number of slots is determined by counting the slots in the given figure of the machine. Hence, the number of slots is $Q = 12$. The number of phases is given in the task, which is $m=3$. Therefore, the pole pitch calculates as:

$$\rho_p = \frac{2\pi}{2p} = \frac{\pi}{5}. \quad (4.43)$$

The number of notches is determined with:

$$q = \frac{Q}{2pm} = \frac{12}{2 \cdot 5 \cdot 3} = \frac{2}{5}. \tag{4.44}$$

Since the number of notches per pole and phase is not an integer, it is a fractional slot winding. The coil width y is one stator slot, as it is shown in the figure. This results in the angular coil width:

$$w = \frac{2\pi}{Q} = \frac{2\pi}{12} = \frac{\pi}{6}. \tag{4.45}$$

Hence, the chording factor is calculated by:

$$s = \frac{w}{\tau_p} = \frac{\pi \cdot 5}{6\pi} = \frac{5}{6}. \tag{4.46}$$

3.2 Complete Tab. 4.2 with the winding scheme for phases b and c. Sketch the resulting winding scheme in Fig. 4.2.

Table 4.2: Winding scheme of a concentrated winding from Fig. 4.2.

Coil nr.	Phase a		Phase b		Phase c	
	In	Out	In	Out	In	Out
1	1	2				
2	1	12				
3	7	6				
4	7	8				

Answer:

In the task only phase a of the winding scheme is given. However, to complete the winding scheme, phase b must have an electrical phase shift of 120° and phase c of 240° respectively. This leads to

$$n_b p \frac{360^\circ}{Q} = 120^\circ \text{ mod } 360^\circ, \tag{4.47}$$

where n_b is the displacement in slots. This expression is rewritten into

$$n_b p \frac{360^\circ}{Q} = 120^\circ + k360^\circ, \tag{4.48}$$

and also for phase c:

$$n_c p \frac{360^\circ}{Q} = 240^\circ + k360^\circ. \tag{4.49}$$

Now, an integral solution must be found for (4.48) and (4.49) to determine the winding scheme. This

is done with trial and error, the first assumption is $n_b = 8, k = 3$, which results in

$$8 \cdot 5 \cdot \frac{360^\circ}{12} = 120^\circ + 3 \cdot 360^\circ, \tag{4.50}$$

$$1200^\circ = 1200^\circ,$$

therefore, the requirement is fulfilled. For phase c the assumption is given with $n_c = 4, k = 1$ into (4.49) leads to

$$4 \cdot 5 \cdot \frac{360^\circ}{12} = 240^\circ + k360^\circ, \tag{4.51}$$

$$600^\circ = 600^\circ,$$

which fulfills the requirement too.

With the coil width of one slot, the resulting winding is determined. The solution of this winding scheme is shown in Sol.-Tab. 4.6.

Solution Table 4.6: Solution of the winding scheme of a concentrated winding.

Coil nr.	Phase a		Phase b		Phase c	
	In	Out	In	Out	In	Out
1	1	2	3	2	4	5
2	1	12	3	4	6	5
3	7	6	8	9	11	10
4	7	8	10	9	11	12

The completed winding scheme is visualized in Fig.4.3.

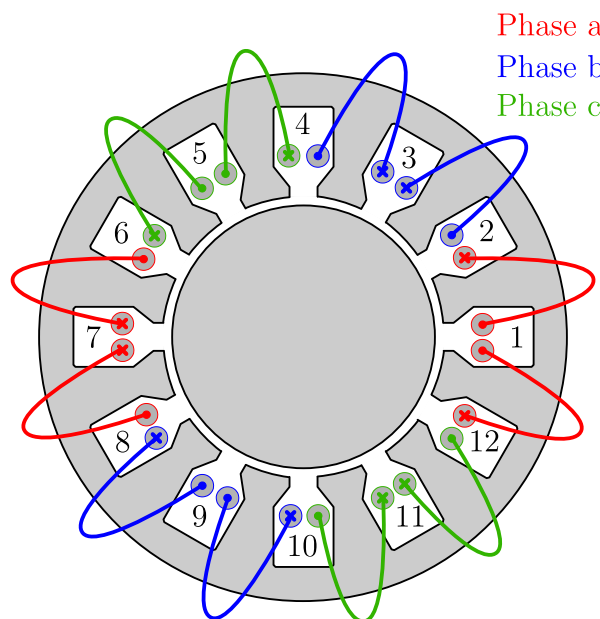

Solution Figure 4.3: Solution of the concentrated winding scheme.

3.3 How many layers are in this winding scheme?

Answer:

There are two layers per slot, therefore, it is a two layer winding scheme.

3.4 Calculate the complex winding factors $\underline{\xi}_{a,k}$ for the fundamental as well as for the 5th and 7th harmonic.

Answer:

The complex winding factor is defined by

$$\underline{\xi}_{a,k} = \frac{1}{jN_a} \sum_{i=1}^Q N_{a,i} e^{jk\vartheta_{el,a,i}}, \quad (4.52)$$

with

$$N_a = \sum_{i=1}^Q |N_{a,i}|, \quad (4.53)$$

and the electrical angle:

$$\vartheta_{el,a,i} = \vartheta_{a,i} \cdot p. \quad (4.54)$$

Hence, the mechanical angles are calculated as follows

$$\vartheta_{a,i} = (i - 1) \frac{360^\circ}{Q} = (i - 1) \cdot \frac{360^\circ}{12} = (i - 1) \cdot 30^\circ, \quad (4.55)$$

where i represents the number of the stator slot. Therefore, the mechanical angles are given in Sol.-Tab. 4.7.

Solution Table 4.7: Mechanical angles of the concentrated winding from Fig. 4.2.

$\vartheta_{a,1} = 0^\circ$	$\vartheta_{a,9} = 180^\circ$
$\vartheta_{a,4} = 30^\circ$	$\vartheta_{a,11} = 210^\circ$
$\vartheta_{a,5} = 150^\circ$	$\vartheta_{a,12} = 330^\circ$

To calculate the winding factors, the total number of turns of the respective phase N_a is determined for each stator slot. A negative sign indicates, that the winding turn is oriented towards the negative z -axis. When no conductor is in a slot, $N_{a,i} = 0$. The result is shown in Sol.-Tab. 4.8.

Solution Table 4.8: Winding turns of phase a of the concentrated winding from Fig. 4.2.

$N_{a1} = 2$	$N_{a2} = -1$	$N_{a6} = 1$
$N_{a7} = -2$	$N_{a8} = 1$	$N_{a12} = -1$

For the fundamental wave, is $k = 1$ and, therefore, with (4.52), the winding factor of the fundamental wave calculates as follows:

$$\underline{\xi}_{a,1} = \frac{1}{8j} \cdot [2e^{j \cdot 1 \cdot 5 \cdot 0^\circ} - e^{j \cdot 1 \cdot 5 \cdot 30^\circ} + e^{j \cdot 1 \cdot 5 \cdot 150^\circ} - 2e^{j \cdot 1 \cdot 5 \cdot 180^\circ} + e^{j \cdot 1 \cdot 5 \cdot 210^\circ} - e^{j \cdot 1 \cdot 5 \cdot 330^\circ}] = -0.9330j, \quad (4.56)$$

with the absolute value:

$$|\xi_{a,1}| = 0.9330. \quad (4.57)$$

For the 5th harmonic is $k = 5$, which results in

$$\xi_{a,5} = \frac{1}{8j} \cdot [2e^{j \cdot 5 \cdot 5 \cdot 0^\circ} - e^{j \cdot 5 \cdot 5 \cdot 30^\circ} + e^{j \cdot 5 \cdot 5 \cdot 150^\circ} - 2e^{j \cdot 5 \cdot 5 \cdot 180^\circ} + e^{j \cdot 5 \cdot 5 \cdot 210^\circ} - e^{j \cdot 5 \cdot 5 \cdot 330^\circ}] = -0.067j, \quad (4.58)$$

with the absolute value:

$$|\xi_{a,5}| = 0.067. \quad (4.59)$$

Finally, the complex winding factor for the 7th harmonic is defined as

$$|\xi_{a,7}| = \frac{1}{8j} \cdot [2e^{j \cdot 7 \cdot 5 \cdot 0^\circ} - e^{j \cdot 7 \cdot 5 \cdot 30^\circ} + e^{j \cdot 7 \cdot 5 \cdot 150^\circ} - 2e^{j \cdot 7 \cdot 5 \cdot 180^\circ} + e^{j \cdot 7 \cdot 5 \cdot 210^\circ} - e^{j \cdot 7 \cdot 5 \cdot 330^\circ}] = -0.067j, \quad (4.60)$$

and, therefore, the absolute value results in:

$$|\xi_{a,7}| = 0.067. \quad (4.61)$$

3.5 Assume a block-shaped distribution of the flux density with a maximal value of $\hat{B} = 1$ T and a number of winding turns $N'_a = 137$. The axial length of the machine is $l = 0.70$ m and the diameter is $d = 0.45$ m. The machine rotates with a mechanical speed of $n = 50 \frac{1}{\text{min}}$. Calculate the induced voltage of phase a for the fundamental wave. What are the 5th and 7th harmonics of the induced voltage in phase a?

Answer:

The Fourier coefficient of the flux density is given with

$$B(\vartheta_{el}, t) = \frac{6}{\pi p} \hat{B} \sum_k^{\infty} \frac{1}{k} \sin\left(\frac{k\pi}{2}\right) \cos(\omega t - k\vartheta_{el}), \quad (4.62)$$

and for the fundamental wave:

$$B^{(1)}(\vartheta_{el}, t) = \frac{6}{\pi p} \hat{B} \sin\left(\frac{\pi}{2}\right) \cos(\omega t - \vartheta_{el}). \quad (4.63)$$

The flux linkage of phase a is calculated as

$$\phi_{a,k}(t) = l \frac{d_s}{2} |\xi_{a,k}| \int_{-\frac{\pi}{2}}^{\frac{\pi}{2}} B(\vartheta_{el}, t) d\vartheta_{el}, \quad (4.64)$$

with the complex winding factor to cover the winding distribution inside the stator. Hence, the

fundamental wave calculates as follows:

$$\begin{aligned}
 \phi_{a,1}(t) &= l \frac{d_s}{2} |\xi_{a,1}| \frac{6}{\pi p} \hat{B} \sin\left(\frac{\pi}{2}\right) \int_{-\frac{\pi}{2}}^{\frac{\pi}{2}} \cos(\omega t - \vartheta_{el}) d\vartheta_{el} \\
 &= l d_s |\xi_{a,1}| \frac{3}{\pi p} \hat{B} \int_{-\frac{\pi}{2}}^{\frac{\pi}{2}} \cos(\omega t) \cos(\vartheta_{el}) + \sin(\omega t) \sin(\vartheta_{el}) d\vartheta_{el} \\
 &= l d_s |\xi_{a,1}| \frac{3}{\pi p} \hat{B} \left[\cos(\omega t) \int_{-\frac{\pi}{2}}^{\frac{\pi}{2}} \cos(\vartheta_{el}) d\vartheta_{el} + \sin(\omega t) \int_{-\frac{\pi}{2}}^{\frac{\pi}{2}} \sin(\vartheta_{el}) d\vartheta_{el} \right] \\
 &= l d_s |\xi_{a,1}| \frac{3}{\pi p} \hat{B} \left[\cos(\omega t) [\sin(\vartheta_{el})]_{-\frac{\pi}{2}}^{\frac{\pi}{2}} + \sin(\omega t) [-\cos(\vartheta_{el})]_{-\frac{\pi}{2}}^{\frac{\pi}{2}} \right] \\
 &= l d_s |\xi_{a,1}| \frac{3}{\pi p} \hat{B} [2 \cos(\omega t)] \\
 &= l d_s |\xi_{a,1}| \frac{6}{\pi p} \hat{B} \cos(\omega t).
 \end{aligned} \tag{4.65}$$

Taking into account also the number of winding turns N'_a , the flux linkage of phase a is given with

$$\psi_{a,k}(t) = N'_a \phi_{a,k}(t), \tag{4.66}$$

which results for the fundamental wave into:

$$\begin{aligned}
 \psi_{a,1}(t) &= N'_a \phi_{a,k}(t) = N'_a l d_s |\xi_{a,1}| \frac{6}{\pi p} \hat{B} \cos(\omega t) \\
 &= 137 \cdot 0.7 \text{ m} \cdot 0.45 \text{ m} \cdot \frac{6}{5\pi} \cdot 1 \text{ T} \cos(\omega t) \cdot 0.9330 \\
 &= 15.38 \text{ Vs} \cdot \cos(\omega t).
 \end{aligned} \tag{4.67}$$

The equation for the induced voltage of the fundamental wave is given with:

$$\begin{aligned}
 u_{\text{ind},a,1}(t) &= -\frac{d}{dt} \psi_{a,1} \\
 &= -\frac{d}{dt} 15.38 \text{ Vs} \cdot \cos(\omega t) \\
 &= 15.38 \text{ Vs} \cdot \sin(\omega t) \omega \\
 &= 15.38 \text{ Vs} \cdot \sin(\omega t) \cdot 2\pi \cdot 5 \cdot \frac{50}{60} \frac{1}{\text{s}} \\
 &= 402.6 \text{ V} \cdot \sin(\omega t).
 \end{aligned} \tag{4.68}$$

The flux linkage of the 5th harmonic is determined with (4.64), which results into:

$$\begin{aligned}
 \phi_{a,5}(t) &= l \frac{d_s}{2} |\xi_{a,5}| \frac{6}{\pi p} \hat{B} \frac{1}{5} \sin\left(\frac{5\pi}{2}\right) \int_{-\frac{\pi}{2}}^{\frac{\pi}{2}} \cos(\omega t - 5\vartheta_{el}) d\vartheta_{el} \\
 &\vdots \\
 &= l \frac{d_s}{2} |\xi_{a,5}| \frac{6}{\pi p} \hat{B} \frac{1}{5} \cos(\omega t).
 \end{aligned} \tag{4.69}$$

The resulting flux linkage is calculated by taking into account the number of winding turns as

$$\begin{aligned}\psi_{a,5} &= N'_a \phi_{a,5}(t) = N'_a l \frac{d_s}{2} |\xi_{a,5}| \frac{6}{\pi p} \hat{B} \frac{1}{5} \cos(\omega t) \\ &= 137 \cdot 0.7 \text{ m} \cdot \frac{0.45}{2} \text{ m} \cdot \frac{6}{5\pi} \cdot 1 \text{ T} \cdot \frac{1}{5} \cdot \cos(\omega t) \cdot 0.0067 \\ &= 0.2208 \text{ Vs} \cdot \cos(\omega t),\end{aligned}\tag{4.70}$$

therefore, the induced voltage is given with:

$$\begin{aligned}u_{\text{ind},a,5}(t) &= -\frac{d}{dt} \psi_{a,5} \\ &= 0.2208 \text{ Vs} \cdot \sin(\omega t) \omega \\ &= 0.2208 \text{ Vs} \cdot 2\pi \cdot 5 \cdot \frac{50}{60} \frac{1}{\text{s}} \\ &= 5.78 \text{ V} \cdot \sin(\omega t).\end{aligned}\tag{4.71}$$

With (4.33) the flux linkage for the 7th harmonic is calculated by:

$$\begin{aligned}\phi_{a,7}(t) &= l \frac{d_s}{2} |\xi_{a,7}| \frac{6}{\pi p} \hat{B} \frac{1}{7} \sin\left(\frac{7\pi}{2}\right) \int_{-\frac{\pi}{2}}^{\frac{\pi}{2}} \cos(\omega t - 7\vartheta_{\text{el}}) d\vartheta_{\text{el}} \\ &\vdots \\ &= l \frac{d_s}{2} |\xi_{a,7}| \frac{6}{\pi p} \hat{B} \frac{1}{7} \cos(\omega t).\end{aligned}\tag{4.72}$$

The resulting flux linkage is calculated by taking into account the number of winding turns as

$$\begin{aligned}\psi_{a,7} &= N'_a \phi_{a,7}(t) = N'_a l \frac{d_s}{2} |\xi_{a,7}| \frac{6}{\pi p} \hat{B} \frac{1}{7} \cos(\omega t) \\ &= 137 \cdot 0.7 \text{ m} \cdot \frac{45}{2} \text{ m} \cdot \frac{6}{5\pi} \cdot 1 \text{ T} \cdot \frac{1}{7} \cdot \cos(\omega t) \cdot 0.067 \\ &= 0.0156 \text{ Vs} \cdot \cos(\omega t),\end{aligned}\tag{4.73}$$

therefore, the induced voltage is given with:

$$\begin{aligned}u_{\text{ind},a,7}(t) &= -\frac{d}{dt} \psi_{a,7} \\ &= 0.0156 \text{ Vs} \cdot \sin(\omega t) \omega \\ &= 0.0156 \text{ Vs} \cdot 2\pi \cdot 5 \cdot \frac{50}{60} \frac{1}{\text{s}} \\ &= 4.13 \text{ V}.\end{aligned}\tag{4.74}$$

3.6 Calculate with a Python script the complex winding factor $\underline{\xi}_{a,k}$ up to various harmonics.

Answer:

The Python script is separately available, therefore, only the solution is presented in Tab 4.9.

Solution Table 4.9: Complex winding factors $\underline{\xi}_{a,k}$ for the concentrated winding up to the 12th harmonic order.

$\underline{\xi}_{a,1} = -0.9330j$	$\underline{\xi}_{a,2} = 0$	$\underline{\xi}_{a,3} = -0.5j$	$\underline{\xi}_{a,4} = 0$
$\underline{\xi}_{a,5} = -0.0670j$	$\underline{\xi}_{a,6} = 0$	$\underline{\xi}_{a,7} = -0.0670j$	$\underline{\xi}_{a,8} = 0$
$\underline{\xi}_{a,9} = -0.5j$	$\underline{\xi}_{a,10} = 0$	$\underline{\xi}_{a,11} = -0.9330j$	$\underline{\xi}_{a,12} = 0$

Exercise 05: Transient and steady state of an induction machine

Acknowledgement: The following exercise is adapted from “Geregelte Drehstromantriebe / Controlled AC Drives” by J. Böcker, Paderborn University, 2021

Task 1: Transient simulation of an induction machine

Given is a squirrel cage motor with the characteristics in Tab. 5.1. The motor is operated with the stator frequency $f_s = 50$ Hz and a line-to-line voltage of $U_{ll} = 400$ V, that is, connected to grid.

Table 5.1: Characteristics of the induction machine.

Symbol	Description	Value
T_n	Nominal torque	4.7 Nm
I_n	Nominal phase current	3.9 A
P_n	Nominal power	1.5 kW
n_n	Nominal speed	$3000 \frac{1}{\text{min}}$

1.1 Determine the equations of the induction machine in the rotor flux oriented coordinate system. Therefore, only the stator current $i_{s,dq}(t)$ and the rotor flux $\psi_{r,d}(t)$ should occur as state variables.

Answer:

The stator equations in the k coordinate system from the lecture are defined by:

$$\frac{d}{dt}\psi_{s,d}^k(t) = \omega_{k,el}\psi_{s,q}^k(t) + u_{s,d}^k(t) - R_s i_{s,d}^k(t), \quad (5.1)$$

$$\frac{d}{dt}\psi_{s,q}^k(t) = -\omega_{k,el}\psi_{s,d}^k(t) + u_{s,q}^k(t) - R_s i_{s,q}^k(t). \quad (5.2)$$

The rotor equations in the k coordinate system are defined as:

$$\frac{d}{dt}\psi_{r,d}^k(t) = (\omega_{k,el}(t) - \omega_{r,el}(t))\psi_{r,q}^k(t) + u_{r,d}^k(t) - R_r i_{r,d}^k(t), \quad (5.3)$$

$$\frac{d}{dt}\psi_{r,q}^k(t) = -(\omega_{k,el}(t) - \omega_{r,el}(t))\psi_{r,d}^k(t) + u_{r,q}^k(t) - R_r i_{r,q}^k(t). \quad (5.4)$$

For the further consideration, only the stator current and the rotor flux are of interest as state variables. Therefore, the rotor current and stator flux are being eliminated with the help of the following equations

$$\begin{aligned} i_{r,d}(t) &= \frac{1}{L_r}\psi_{r,d}(t) - \frac{M_r}{L_r}i_{s,d}(t), \\ i_{r,q}(t) &= \frac{1}{L_r}\psi_{r,q}(t) - \frac{M_r}{L_r}i_{s,q}(t), \end{aligned} \quad (5.5)$$

and:

$$\begin{aligned}\psi_{s,d}(t) &= \sigma L_s i_{s,d}(t) + \frac{M_s}{L_r} \psi_{r,d}(t), \\ \psi_{s,q}(t) &= \sigma L_s i_{s,q}(t) + \frac{M_s}{L_r} \psi_{r,q}(t).\end{aligned}\quad (5.6)$$

These equations are derived from the magnetic circuit of the induction machine.

The rotor current from (5.5) is inserted in the rotor equation (5.3). In addition, the coordinate system is aligned with the rotor flux. This results in the following equation for the d-axis:

$$\frac{d}{dt} \psi_{r,d}(t) = (\omega_{k,el}(t) - \omega_{r,el}(t)) \psi_{r,q}(t) + u_{r,d}(t) - R_r \left(\frac{1}{L_r} \psi_{r,d}(t) - \frac{M_r}{L_r} i_{s,d}(t) \right). \quad (5.7)$$

Within the rotor flux-oriented coordinate system, only a flux in d-axis occurs, therefore, the equation can be simplified into

$$\frac{d}{dt} \psi_{r,d} = u_{r,d}(t) - \frac{R_r}{L_r} \psi_{r,d}(t) + \frac{R_r M_r}{L_r} i_{s,d}(t), \quad (5.8)$$

and due to the squirrel cage machine the rotor voltage is zero. This leads to:

$$\frac{d}{dt} \psi_{r,d} = -\frac{R_r}{L_r} \psi_{r,d}(t) + \frac{R_r M_r}{L_r} i_{s,d}(t). \quad (5.9)$$

For the q-axis, the rotor current from (5.5) is also used in the rotor flux differential equation. This leads to:

$$\frac{d}{dt} \psi_{r,q}(t) = -(\omega_{k,el}(t) - \omega_{r,el}(t)) \psi_{r,d}(t) + u_{r,q}(t) - R_r \left(\frac{1}{L_r} \psi_{r,q}(t) - \frac{M_r}{L_r} i_{s,q}(t) \right), \quad (5.10)$$

and with the definition for $\psi_{r,q}(t) = 0$:

$$\frac{d}{dt} \psi_{r,q}(t) = 0 = -(\omega_{k,el}(t) - \omega_{r,el}(t)) \psi_{r,d}(t) + u_{r,q}(t) + R_r \frac{M_r}{L_r} i_{s,q}(t). \quad (5.11)$$

Due to the squirrel cage motor type, the rotor voltage is zero. However, the slip frequency is determined from this equation as follows:

$$-(\omega_{k,el}(t) - \omega_{r,el}(t)) = R_r \frac{M_r}{L_r} \frac{i_{s,q}(t)}{\psi_{r,d}(t)}. \quad (5.12)$$

In the next step, the stator flux is eliminated in (5.1). Therefore, (5.6) is used as follows

$$\sigma L_s \frac{d}{dt} i_{s,d}(t) + \frac{M_s}{L_r} \frac{d}{dt} \psi_{r,d}(t) = \omega_{k,el}(t) \left(\sigma L_s i_{s,q}(t) + \frac{M_s}{L_r} \psi_{r,q}(t) \right) + u_{s,d}(t) - R_s i_{s,d}(t), \quad (5.13)$$

with the derivative of the previous determined rotor flux

$$\sigma L_s \frac{d}{dt} i_{s,d}(t) + \frac{M_s}{L_r} \left(u_{r,d}(t) - \frac{R_r}{L_r} \psi_{r,d}(t) + \frac{R_r M_r}{L_r} i_{s,d}(t) \right) = \omega_{k,el} \sigma L_s i_{s,q}(t) + u_{s,d}(t) - R_s i_{s,d}(t), \quad (5.14)$$

which leads to:

$$\begin{aligned} \frac{d}{dt}i_{s,d}(t) = \frac{1}{\sigma L_s} \left[-\frac{M_s}{L_r}u_{r,d}(t) + \psi_{r,d}(t)\frac{M_s R_r}{L_r^2} \right. \\ \left. + \omega_{k,el}(t)\sigma L_s i_{s,q}(t) + u_{s,d}(t) + i_{s,d}(t) \left(-\frac{R_r M_s^2}{L_r^2} - R_s \right) \right]. \end{aligned} \quad (5.15)$$

Again, eliminate the stator flux in the ode with (5.6) for the q-axis, which leads to

$$\sigma L_s \frac{d}{dt}i_{s,q}(t) + \frac{M_s}{L_r} \frac{d}{dt}\psi_{r,q}(t) = -\omega_{k,el}(t)\psi_{s,d}(t) + u_{s,q}(t) - R_s i_{s,q}(t), \quad (5.16)$$

with $\psi_{r,q} = 0$ and the derivative $\frac{d}{dt}\psi_{r,q} = 0$, the equation results in:

$$\sigma L_s \frac{d}{dt}i_{s,q}(t) = -\omega_{k,el}(t)\psi_{s,d}(t) + u_{s,q}(t) - R_s i_{r,q}(t). \quad (5.17)$$

Hence, the ODEs for the stator currents and the rotor flux are given in the following. It starts with the d-current component, which is given with:

$$\begin{aligned} \frac{d}{dt}i_{s,d}(t) = \frac{1}{\sigma L_s} \left[-\frac{M_s}{L_r}u_{r,d}(t) + \psi_{r,d}(t)\frac{M_s R_r}{L_r^2} \right. \\ \left. + \omega_{k,el}(t)\sigma L_s i_{s,q}(t) + u_{s,d}(t) + i_{s,d}(t) \left(-\frac{R_r M_s^2}{L_r^2} - R_s \right) \right], \end{aligned} \quad (5.18)$$

for the stator q-current

$$\frac{d}{dt}i_{s,q}(t) = \frac{1}{\sigma L_s} [-\omega_{k,el}(t)\psi_{s,d}(t) + u_{s,q}(t) - R_s i_{r,q}(t)], \quad (5.19)$$

and the rotor flux in the d-axis:

$$\frac{d}{dt}\psi_{r,d} = -\frac{R_r}{L_r}\psi_{r,d}(t) + \frac{R_r M_r}{L_r}i_{s,d}(t). \quad (5.20)$$

To simulate the induction machine, also the mechanical part must be taken into account. Hence, the mechanical equation is given by

$$J \frac{d}{dt}\omega_{r,el}(t) = T(t) - T_1(t), \quad (5.21)$$

where $T(t)$ represents the produced torque and $T_1(t)$ is the load torque. This leads to

$$\frac{d}{dt}\omega_{r,el}(t) = \frac{1}{J} (T(t) - T_1(t)), \quad (5.22)$$

where $T(t)$ is defined as

$$T(t) = -\frac{3}{2}p \left(i_{r,dq}^k(t) \right)^\top \mathbf{J} \psi_{r,dq}^k(t), \quad (5.23)$$

which results in the rotor oriented coordinate system into:

$$T(t) = \frac{3}{2}p i_{r,d}(t) \psi_{r,q}(t) - \frac{3}{2}p i_{r,q}(t) \psi_{r,d}(t). \quad (5.24)$$

The first part from the equation above is zero, due to the definition of the coordinate system. The rotor current is replaced with (5.5), that leads to:

$$\begin{aligned} T(t) &= -\frac{3}{2}p \left(\frac{1}{L_r} \psi_{r,q}(t) - \frac{M_r}{L_r} i_{s,q}(t) \right) \psi_{r,d}(t) \\ &= \frac{3}{2} \frac{M_r}{L_r} i_{s,q}(t) \psi_{r,d}(t). \end{aligned} \quad (5.25)$$

1.2 Write a Jupyter notebook to solve the derived equations in the dq coordinate system aligned to the rotor flux from the previous task. First, simulate the machine with no load. Analyze the transient motor response starting from the initial state $i_d(t=0) = i_q(t=0) = \psi_d(t=0) = \omega_{el}(t=0) = \epsilon_{el}(t=0) = 0$ when excited with the above-mentioned stator voltage. Simulate as well as visualize the torque, speed, flux and current responses and plot the latter two in abc, $\alpha\beta$ and dq coordinates.

Answer:

The current in the dq coordinate system is shown in Sol.-Fig. 5.1. After the steady state is reached, the current values are constant, which could be expected in the rotor flux-oriented coordinate system.

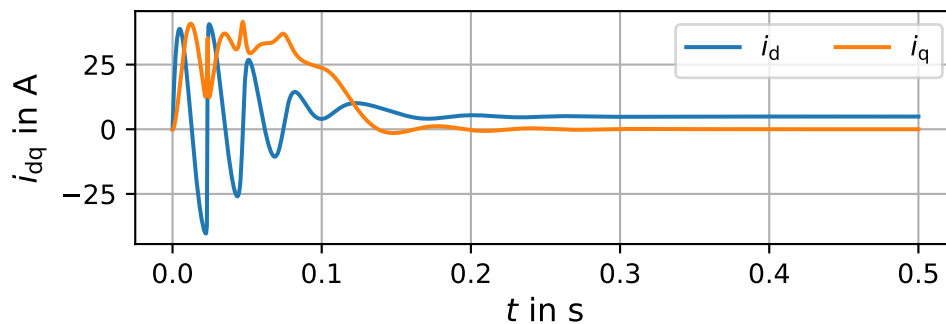

Solution Figure 5.1: Transient process of an IM in the dq coordinate system.

In Sol.-Fig. 5.2 the current in the α, β coordinate system is visualized. The transient process is also clearly visible in this coordinate system.

Sol.-Fig. 5.3 shows the transient process of the current in the three-phase abc coordinate system.

Compared to the abc current plot, one can observe also a sinusoidal signalform with the same amplitude and frequency evolution, while the phase difference between the currents is 120° in abc and 90° in $\alpha\beta$. This fits to the expectations resulting from the amplitude-invariant Clarke transformation.

The electrical angular frequency of the stator and the angular frequency of the rotor are shown in

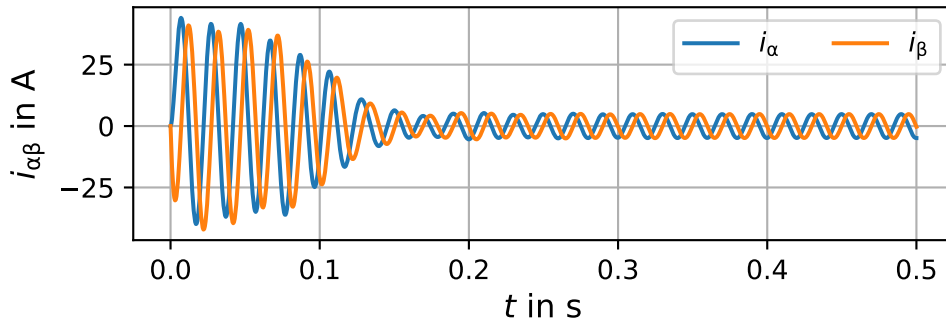

Solution Figure 5.2: Transient process of an IM in the $\alpha\beta$ coordinate system.

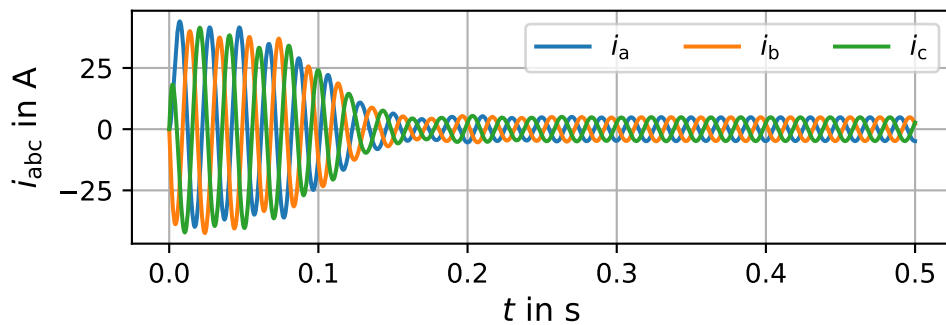

Solution Figure 5.3: Transient process of an IM in the abc coordinate system.

Sol.-Fig. 5.4. Due to the no load operation (also no friction) of the IM, the angular frequency of the rotor is equal to the angular electrical stator frequency.

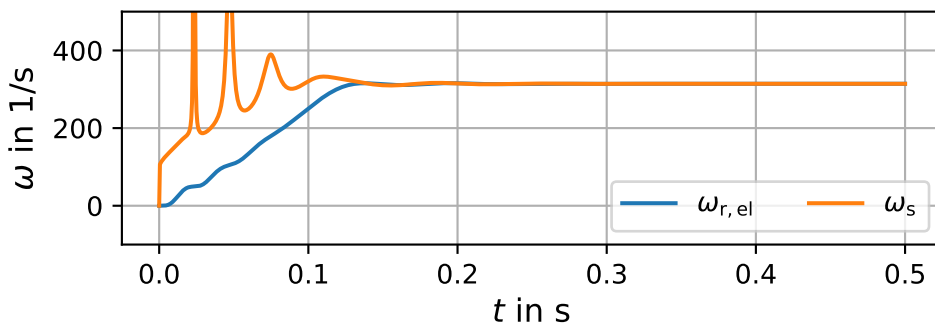

Solution Figure 5.4: Electric angular frequency of the stator and angular frequency of the rotor during the transient process at no load.

The produced torque is shown in Sol.-Fig. 5.5. During the transient process, very high torque values are reached and an oscillation of the rotor is visible. In the steady state, the torque is equal to zero, due to the no-load operation.

In Sol.-Fig. 5.6 the rotor flux is shown, which also shows the transient process. The d-axis of the coordinate system is oriented on the rotor flux and, therefore, the flux aligned to the q-axis is zero. Thus, only the rotor flux aligned to the d-axis is visualized.

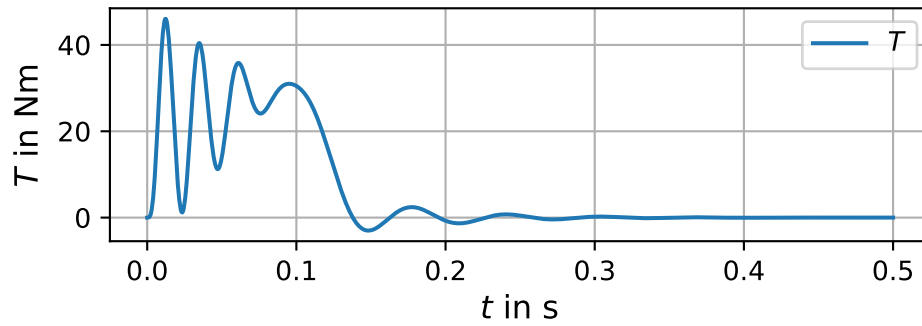

Solution Figure 5.5: Produced torque of an IM during the transient process at no load.

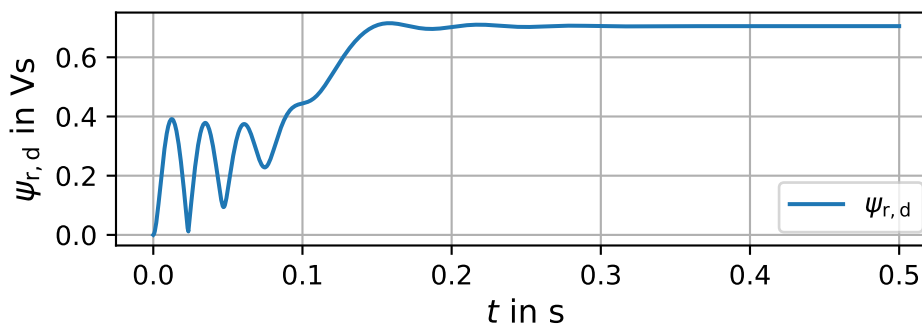

Solution Figure 5.6: Rotor flux in dq coordinate system during the transient process at no load.

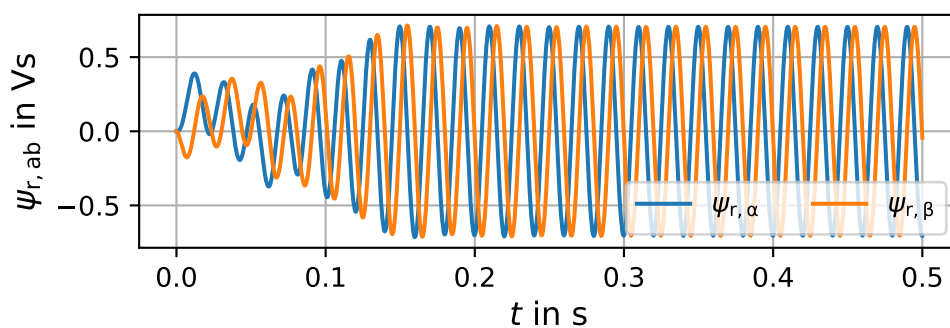

Solution Figure 5.7: Rotor flux in $\alpha\beta$ coordinate system during the transient process at no load.

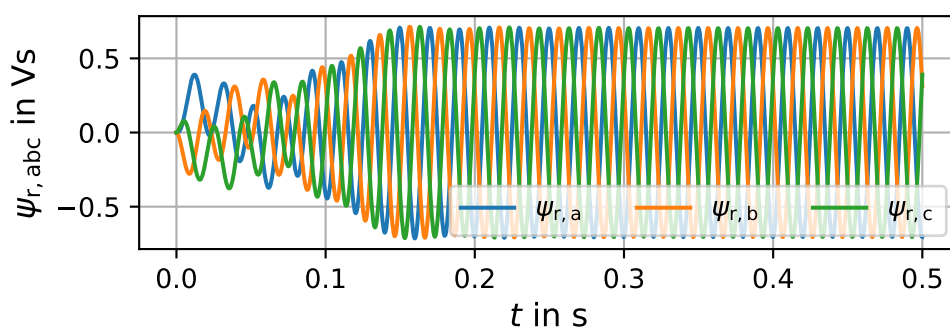

Solution Figure 5.8: Rotor flux in abc coordinate system during the transient process at no load.

1.3 Add a speed dependent load with the following equation $T_l = 0.00004 * \omega_{r,el}^2$ to the machine model. Repeat the simulation from the previous task. How does the currents, torque and flux change? In addition, how changes the rotational speed of the machine between these two operating points?

Answer:

In Sol.-Fig. 5.9 the speed of the stator and rotor field is visualized. For this simulation a load term representing the friction is added, thus this load is speed dependent. Hence, this results in a different speed of the rotor in the steady state in comparison to the stator field. This occurs due to the load of the machine, and is representing with the slip of the machine.

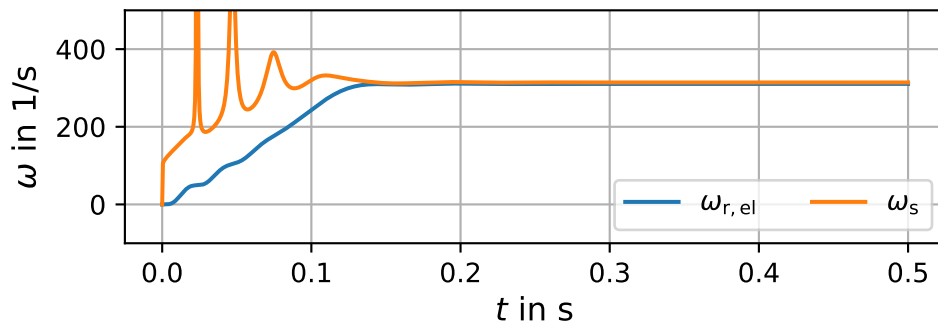

Solution Figure 5.9: Electrical angular frequency of the stator and angular frequency of the rotor during the transient process with a speed dependent load.

To highlight the difference between the stator and rotor field, in Sol.-Fig. 5.10 the boundaries of the vertical axis are limited. Hence, the speed difference in the steady state is clearly visible.

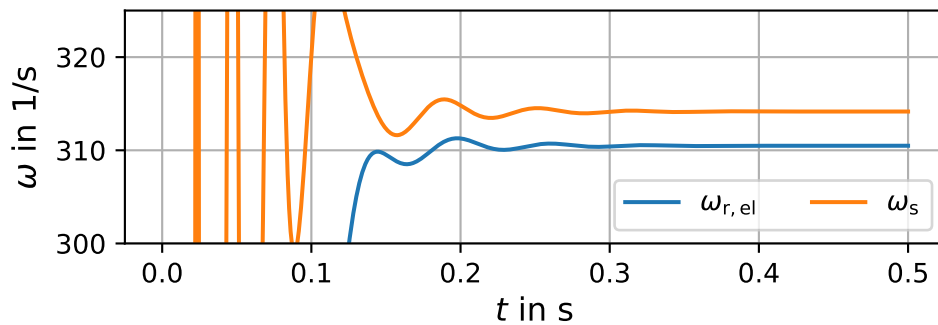

Solution Figure 5.10: Zoom into the electrical angular frequency of the stator and angular frequency of the rotor to visualize the difference in the steady state.

The produced torque during the transient process is shown in Sol.-Fig. 5.11. Sol.-Fig. 5.12 shows a zoomed version of the produced torque to highlight the torque in the steady state.

In Sol.-Fig. 5.13 the currents in the dq coordinate system are visualized. Due to the load and, thus, the generated torque, the current i_q is no longer zero in the steady state.

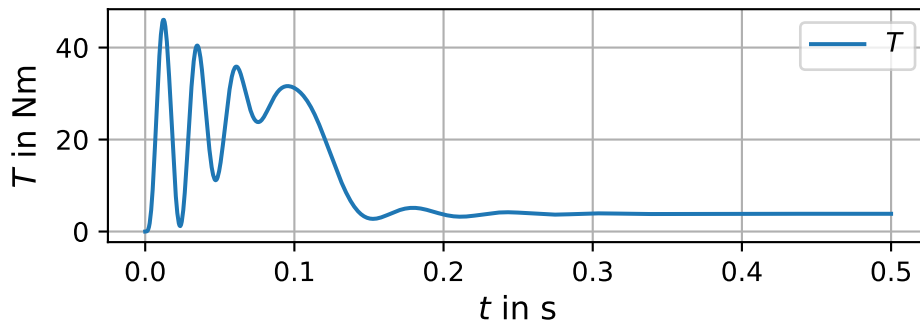

Solution Figure 5.11: Produced torque of an IM during the transient process and in the steady-state operation with a speed-dependent load.

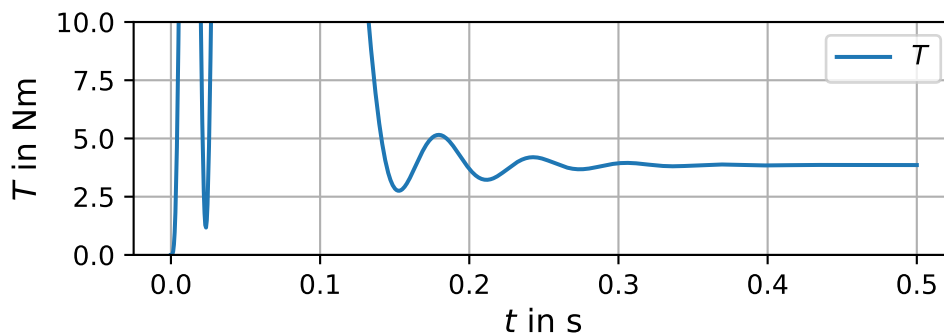

Solution Figure 5.12: Produced torque of an IM during the transient process and in the steady-state operation with a speed-dependent load.

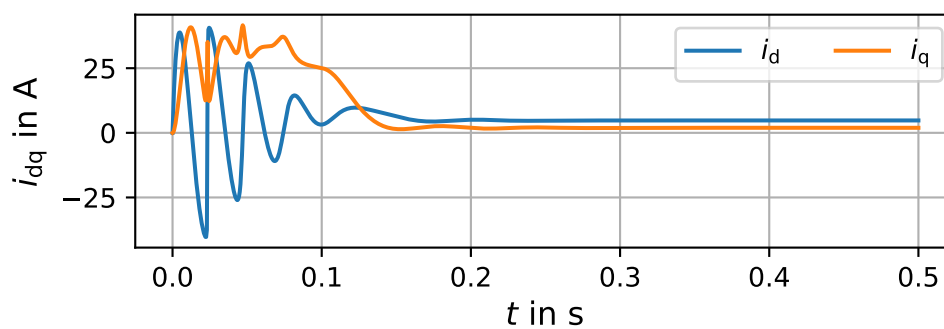

Solution Figure 5.13: Currents in dq coordinate system of an IM during the transient process and in the steady-state operation with a speed-dependent load.

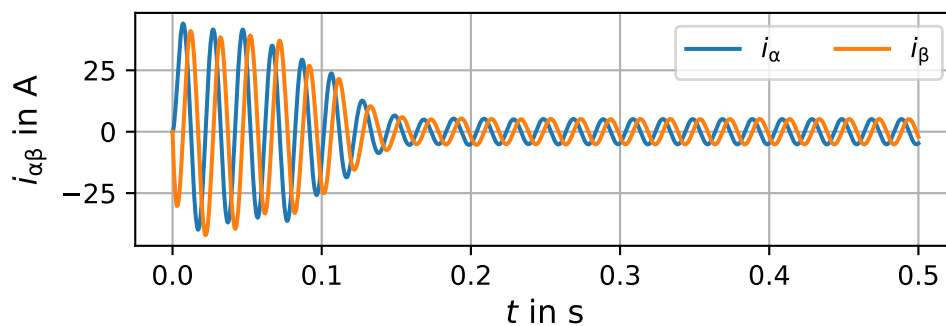

Solution Figure 5.14: Currents in $\alpha\beta$ coordinate system of an IM during the transient process and in the steady-state operation with a speed-dependent load.

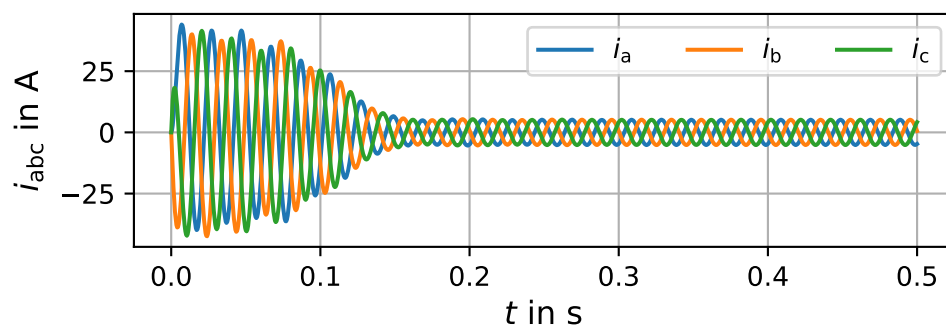

Solution Figure 5.15: Currents in abc coordinate system of an IM during the transient process and in the steady-state operation with a speed-dependent load.

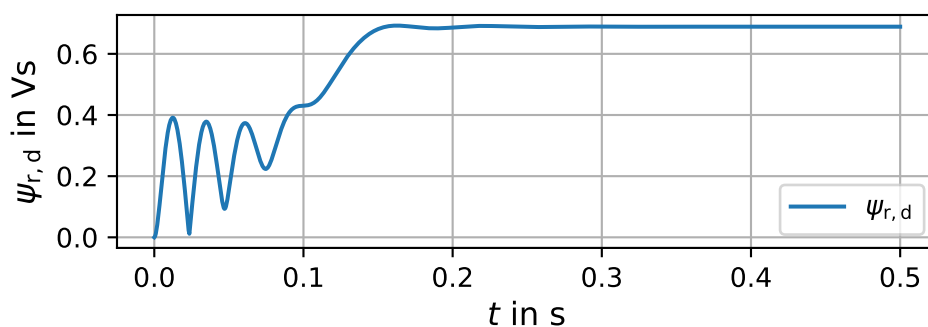

Solution Figure 5.16: Rotor flux linkage in dq coordinate system of an IM during the transient process and in the steady-state operation with a speed-dependent load.

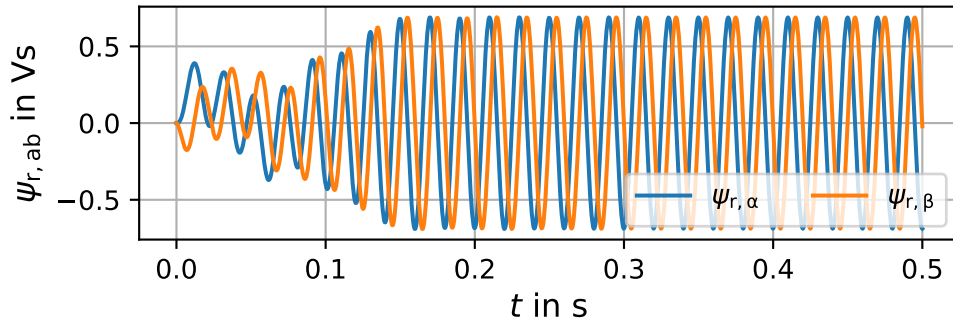

Solution Figure 5.17: Rotor flux linkage in $\alpha\beta$ coordinate system of an IM during the transient process and in the steady-state operation with a speed-dependent load.

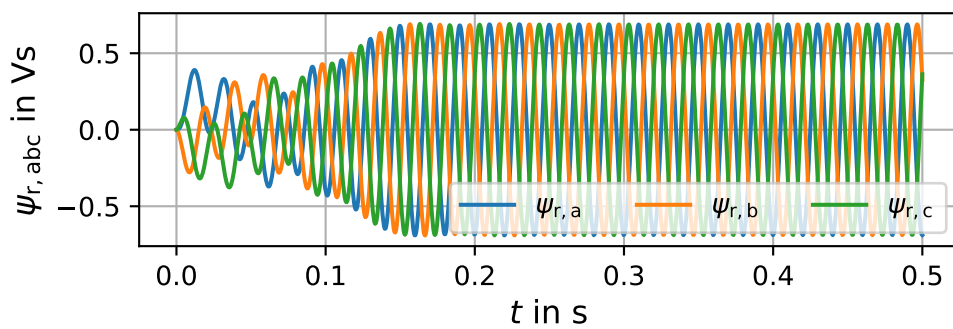

Solution Figure 5.18: Rotor flux linkage in abc coordinate system of an IM during the transient process and in the steady-state operation with a speed-dependent load.

Task 2: Steady-state operation of an induction machine

An induction machine with the characteristics in Tab. 5.2 is given.

Table 5.2: Characteristics of the given induction machine.

Symbol	Description	Values
U_n	Nominal voltage	380 V
I_n	Nominal phase current	54 A
$f_{s,n}$	Nominal frequency	50 Hz
P_n	Nominal power	25 kW
n_n	Nominal speed	1465 $\frac{1}{\text{min}}$
$\cos(\varphi)$	Power factor	0.77
R_s	Stator resistance	0.48 Ω
R'_r	Rotor resistance	85 m Ω
M	Mutual inductance	100 mH
$L_{\sigma,s}$	Stator leakage inductance	2 mH
$L'_{\sigma,r}$	Rotor leakage inductance	2 mH

2.1 Determine the amplitude of the complex AC voltage \hat{U} and current phasor \hat{I} .

Answer:

The amplitude of the line-to-line voltage is given with

$$\hat{U} = \sqrt{2} \cdot 380 \text{ V} = 537.4 \text{ V}, \tag{5.26}$$

and, therefore, the amplitude of the phase-to-star-point voltage is defined as:

$$\hat{U}_{\text{star}} = \frac{380 \text{ V}}{\sqrt{3}} \cdot \sqrt{2} = 310.9 \text{ V}. \tag{5.27}$$

Furthermore, the current amplitude is defined by:

$$\hat{I} = \sqrt{2} I = \sqrt{2} \cdot 54 \text{ A} = 76.4 \text{ A}. \tag{5.28}$$

2.2 Determine the number of pole pairs p .

Answer:

The stator frequency is given with $f_s = 50 \text{ Hz}$, which leads to the synchronous rotational speed of the electrical frequency as follows:

$$n_{\text{syn,el}} = 50 \text{ Hz} \cdot 60 \frac{\text{s}}{\text{min}} = 3000 \frac{1}{\text{min}}. \tag{5.29}$$

The nominal speed is given with $n_n = 1465 \frac{1}{\text{min}}$, which is associated with a synchronous speed of $n_{\text{syn,mech}} = 1500 \frac{1}{\text{min}}$.

Therefore, the number of pole pairs is defined with:

$$p = \frac{n_{\text{syn,el}}}{n_{\text{syn,mech}}} = \frac{3000 \frac{1}{\text{min}}}{1500 \frac{1}{\text{min}}} = 2. \quad (5.30)$$

2.3 Calculate the rated slip s_n . Which slip occurs at an ideal no-load operation (no friction)?

Answer:

The slip is calculated by:

$$s_n = \frac{\omega_{\text{slip,n}}}{\omega_s} = \frac{\omega_s - p\omega_r}{\omega_s} = \frac{2\pi \cdot \frac{3000}{60} \frac{1}{\text{s}} - 2 \cdot 2\pi \cdot \frac{1465}{60} \frac{1}{\text{s}}}{2\pi \cdot \frac{3000}{60} \frac{1}{\text{s}}} = 0.023, \quad (5.31)$$

where ω_r is the rotor speed. At an ideal no-load operation (also no friction), the rotor has the same speed as the stator field and, therefore, $s = 0$.

2.4 Calculate the apparent, the reactive and the electrical power. In addition, determine the efficiency η_n for the rated operating point.

Answer:

The apparent power is calculated with

$$S = \sqrt{3}UI = \sqrt{3} \cdot 380 \text{ V} \cdot 54 \text{ A} = 35.541 \text{ kVA}, \quad (5.32)$$

and, the electrical power is determined with the power factor in the task as follows:

$$P_{\text{el,n}} = \sqrt{3}UI \cos(\varphi) = \sqrt{3} \cdot 380 \text{ V} \cdot 54 \text{ A} \cdot 0.77 = 27.367 \text{ kW}. \quad (5.33)$$

The angle of the phase shift is calculated by:

$$\varphi = \cos^{-1}(0.77) = 39.6^\circ. \quad (5.34)$$

Hence, the reactive power yields:

$$Q = \sqrt{3}UI \sin(\varphi) = \sqrt{3} \cdot 380 \text{ V} \cdot 54 \text{ A} \cdot \sin(39.6^\circ) = 22.655 \text{ kVA}. \quad (5.35)$$

The efficiency results as:

$$\eta_n = \frac{P_{\text{mech,n}}}{P_{\text{el,n}}} = \frac{25 \text{ kW}}{27.367 \text{ kW}} = 0.914. \quad (5.36)$$

2.5 Determine the nominal torque generated by the induction machine.

Answer:

The torque is calculated as:

$$T_n = \frac{P_{\text{mech}}}{\omega_{\text{mech}}} = \frac{25 \text{ kW}}{2\pi \cdot \frac{1465}{60} \frac{1}{\text{s}}} = 163 \text{ Nm}. \quad (5.37)$$

2.6 Calculate the starting T_0 and the maximum torque T_{\max} . For the latter determine first the slip s_{\max} at the operating point with the maximum torque.

Answer:

The slip at the maximum torque operating point is defined by

$$s_{\max} = \frac{R'_r}{\sigma (L'_{\sigma,r} + M) \omega_s} = \frac{85 \text{ m}\Omega}{0.038 \cdot (2 \text{ mH} + 100 \text{ mH}) \cdot 2\pi \cdot 50 \frac{1}{\text{s}}} = 0.068, \quad (5.38)$$

with the leakage coefficient:

$$\begin{aligned} \sigma &= 1 - \frac{M^2}{(M + L_{\sigma,s})(M + L'_{\sigma,r})} \\ &= 1 - \frac{(100 \text{ mH})^2}{(102 \text{ mH}) \cdot (102 \text{ mH})} \\ &= 0.038. \end{aligned} \quad (5.39)$$

Hence, the maximum torque is calculated with:

$$\begin{aligned} T_{\max} &= \frac{3}{2} p \frac{U_s^2}{\omega_s^2} \frac{M^2}{\sigma (L_{\sigma,s} + M)^2 (L'_{\sigma,r} + M)} \\ &= \frac{3}{2} \cdot 2 \cdot \frac{\frac{380 \text{ V}}{\sqrt{3}}}{\left(2\pi \cdot 50 \frac{1}{\text{s}}\right)^2} \cdot \frac{100 \text{ mH}}{0.038 \cdot (102 \text{ mH})^2 \cdot (102 \text{ mH})} \\ &= 355 \text{ Nm}. \end{aligned} \quad (5.40)$$

The starting torque is determined as follows:

$$T_0 = T_{\max} \frac{2s_{\max}}{1 + s_{\max}^2} = 355 \text{ Nm} \cdot \frac{2 \cdot 0.068}{1 + 0.068^2} = 48.3 \text{ Nm}. \quad (5.41)$$

2.7 Determine the stator currents $I_{s,dq}$, and, in addition, the induced rotor currents $I_{r,dq}$.

Answer:

Derived from the lecture notes, the stator currents are calculated as follows:

$$\begin{aligned} I_{s,d} &= \frac{U_s}{\omega_s} \frac{\sigma^2 \omega_{\text{slip}}^2 (L_{\sigma,s} + M) (L'_{\sigma,r} + M)^3 + (L'_{\sigma,r} + M) (L_{\sigma,s} + M) (R'_r)^2 - M^2 (R'_r)^2}{\sigma (L_{\sigma,s} + M)^2 (L'_{\sigma,r} + M) \omega_{\text{slip}} \left(\sigma^2 \omega_{\text{slip}}^2 (L'_{\sigma,r} + M)^2 + (R'_r)^2 \right)} \\ &= 3.3 \text{ A}, \end{aligned} \quad (5.42)$$

$$I_{s,d} = \frac{U_s}{\omega_s} \frac{M^2}{\sigma (L_{\sigma,s} + M)^2 (L'_{\sigma,r} + M)} \frac{1}{\frac{\omega_{\text{slip}}}{\omega_{\max}} + \frac{\omega_{\max}}{\omega_{\text{slip}}}} = 51.8 \text{ A}. \quad (5.43)$$

The rotor currents are calculated as follows:

$$I_{r,d} = -U_s \frac{Ms}{(L_{\sigma,s} + M) R'_r} \frac{1}{\frac{\omega_{slip}}{\omega_{max}} + \frac{\omega_{max}}{\omega_{slip}}} = -18.06 \text{ A}, \quad (5.44)$$

$$I_{r,q} = -\frac{U_s}{\omega_s \sigma} \frac{M}{(L_{\sigma,s} + M) (L'_{\sigma,r} + M)} \frac{1}{\frac{\omega_{slip}}{\omega_{max}} + \frac{\omega_{max}}{\omega_{slip}}} = -52.9 \text{ A}. \quad (5.45)$$

2.8 Calculate the losses in the stator winding and in the rotor.

Answer:

The stator current is determined by

$$I_{s,dq} = \sqrt{I_{s,d}^2 + I_{s,q}^2} = \sqrt{(3.3 \text{ A})^2 + (51.8 \text{ A})^2} = 51.9 \text{ A}, \quad (5.46)$$

which results to the stator winding losses as follows:

$$P_{l,\text{stator}} = \frac{3}{2} I_{s,dq}^2 R_s = \frac{3}{2} \cdot (51.9 \text{ A})^2 \cdot 0.48 \Omega = 1939.4 \text{ W}. \quad (5.47)$$

The rotor current is calculated in the same way. This leads to

$$I_{r,dq} = \sqrt{I_{r,d}^2 + I_{r,q}^2} = \sqrt{(-18.1 \text{ A})^2 + (-52.9 \text{ A})^2} = 55.9 \text{ A}, \quad (5.48)$$

and the ohmic rotor losses are calculated with:

$$P_{l,\text{rotor}} = \frac{3}{2} I_{r,dq}^2 R'_r = \frac{3}{2} \cdot (55.9 \text{ A})^2 \cdot 85 \text{ m}\Omega = 398.4 \text{ W}. \quad (5.49)$$

2.9 Draw the space vector diagram for the operation under rated conditions including the vectors \underline{u}_s , \underline{i}_s , $\underline{\psi}_s$ and $\frac{d}{dt}\underline{\psi}_s$. Assume that the current vector \underline{i}_s is oriented along the x-axis of the Cartesian coordinate system.

Answer:

The current is aligned with the x-axis of the Cartesian coordinate system. Therefore, the current is given with:

$$\underline{i}_s = \sqrt{2} I e^{j0^\circ} = 76.37 \text{ A} \cdot e^{j0^\circ}. \quad (5.50)$$

The angle shift between the voltage and current is calculated by

$$\varphi_{ui} = 39.65^\circ, \quad (5.51)$$

therefore, the voltage is defined as follows:

$$\underline{u}_s = \sqrt{2} U e^{j\varphi_{ui}} = 310.27 \text{ V} \cdot e^{j39.65^\circ} = 238.89 \text{ V} + j197.98 \text{ V}. \quad (5.52)$$

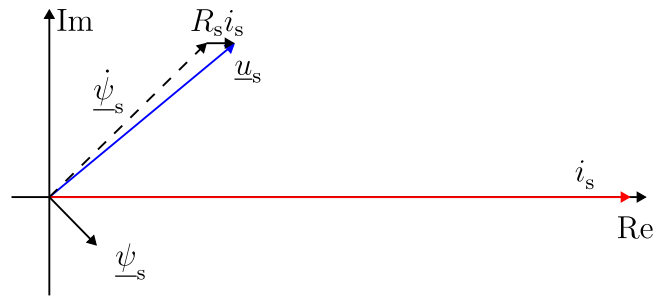

Solution Figure 5.19: Resulting vector diagram of the induction machine in steady state. The scale for the voltage is $1 \text{ cm} \hat{=} 100 \text{ V}$, for the flux linkage $1 \text{ cm} \hat{=} 1 \text{ Vs}$ and for the current $1 \text{ cm} \hat{=} 10 \text{ A}$.

The stator resistance R_s is given in the task. Hence, the voltage equation is defined as:

$$\underline{u}_s = R_s \underline{i}_s + \frac{d}{dt} \underline{\psi}_s. \tag{5.53}$$

Rearranging leads to:

$$\begin{aligned} \frac{d}{dt} \underline{\psi}_s &= \underline{u}_s - R_s \underline{i}_s \\ &= 238.89 \text{ V} + j197.98 \text{ V} - 0.48 \text{ } \Omega \cdot 76.37 \text{ A} \\ &= 202.23 \text{ V} + j197.98 \text{ V} \\ &= 283 \text{ V} \cdot e^{j44.4^\circ}. \end{aligned} \tag{5.54}$$

The stator flux vector is defined as

$$\underline{\psi}_s(t) = \psi_s(t) \cdot e^{j\varphi_s(t)}, \tag{5.55}$$

and the differentiation (under consideration of the product rule) results in:

$$\frac{d}{dt} \underline{\psi}_s(t) = \frac{d}{dt} \psi_s(t) \cdot e^{j\varphi_s(t)} + j\omega_{\varphi_s} \cdot \underline{\psi}_s(t). \tag{5.56}$$

Due to the steady state, the change of the flux amplitude $\left(\frac{d}{dt} \psi(t)\right)$ is zero. The flux vector rotates with the speed ω , therefore, the flux vector is determined as follows:

$$\underline{\psi}_s(t) = \frac{283 \text{ V} \cdot e^{j44.4^\circ}}{314.16 \frac{1}{\text{s}} \cdot e^{j90^\circ}} = 0.90 \text{ Vs} \cdot e^{-j45.6^\circ}. \tag{5.57}$$

Exercise 06: Synchronous machines

Acknowledgement: Parts of the following exercise are adapted from “Elektrische Antriebstechnik” by J. Böcker, Paderborn University, 2020

Task 1: Transient simulation of a salient pole synchronous machine

Given is a salient pole synchronous machine with the parameters in Tab. 6.1.

Table 6.1: Parameters of the salient synchronous machine.

Symbol	Description	Value
R_s	Stator resistance	0.0196 Ω
R_f	Field winding resistance	54.7 Ω
$L_{s,d}$	Stator inductance d-axis	2.7 mH
$L_{s,q}$	Stator inductance q-axis	1.3 mH
L_f	Self field inductance	20.3 mH
M_{fs}	Mutual inductance	92.8 mH
I_n	Nominal stator current	450 A
$I_{f,n}$	Nominal field current	7.854 A

1.1 Calculate the transient response for i_{dq} and i_f if a short circuit occurs at the running machine. Assume $i_{d0} = i_{q0} = 0$, $i_{f0} = i_{f,n}$ for $t = 0$ and a fixed rotational speed $\omega_{r,el}$. Assume further that the ohmic stator resistance can be neglected for the short-term transient response.

Answer:

The machine model is defined as

$$\frac{d}{dt} \begin{bmatrix} i_{s,d}(t) \\ i_{s,q}(t) \\ i_f(t) \end{bmatrix} = \begin{bmatrix} -L_f/\gamma & 0 & M_{fs}/\gamma \\ 0 & 1/L_{s,q} & 0 \\ M_{fs}/\gamma & 0 & -L_{s,d}/\gamma \end{bmatrix} \begin{bmatrix} i_{s,d}(t) \\ i_{s,q}(t) \\ i_f(t) \end{bmatrix} - \begin{bmatrix} 0 & -\omega_{r,el}(t) & 0 \\ \omega_{r,el}(t) & 0 & 0 \\ 0 & 0 & 0 \end{bmatrix} \begin{bmatrix} \psi_{s,d}(t) \\ \psi_{s,q}(t) \\ \psi_f(t) \end{bmatrix} \quad (6.1)$$

with the parameter

$$\gamma = M_{fs}^2 - L_{s,d}L_f, \quad (6.2)$$

and the flux linkages

$$\begin{bmatrix} \psi_{s,d}(t) \\ \psi_{s,q}(t) \\ \psi_f(t) \end{bmatrix} = \begin{bmatrix} L_{s,d} & 0 & M_{fs} \\ 0 & L_{s,q} & 0 \\ M_{fs} & 0 & L_f \end{bmatrix} \begin{bmatrix} i_{s,d}(t) \\ i_{s,q}(t) \\ i_f(t) \end{bmatrix}. \quad (6.3)$$

With the assumption of a constant speed ($\omega_{r,el}(t) = \omega_{r,el}$), the general machine model from (6.1) is rewritten as follows:

$$\frac{d}{dt} \begin{bmatrix} i_{s,d}(t) \\ i_{s,q}(t) \\ i_f(t) \end{bmatrix} = \begin{bmatrix} L_f R_s / \gamma & -L_f L_{s,q} \omega_{r,el} / \gamma & -M_{fs} R_f / \gamma \\ -L_{s,d} \omega_{r,el} / L_{s,q} & -R_s / L_{s,q} & -M_{fs} \omega_{r,el} / L_{s,q} \\ -M_{fs} R_s / \gamma & M_{fs} L_{s,q} \omega_{r,el} / \gamma & L_{s,d} R_f / \gamma \end{bmatrix} \begin{bmatrix} i_{s,d}(t) \\ i_{s,q}(t) \\ i_f(t) \end{bmatrix} + \begin{bmatrix} -L_f / \gamma & 0 & M_{fs} / \gamma \\ 0 & 1 / L_{s,q} & 0 \\ M_{fs} / \gamma & 0 & -L_{s,d} / \gamma \end{bmatrix} \begin{bmatrix} u_{s,d}(t) \\ u_{s,q}(t) \\ u_f(t) \end{bmatrix}. \quad (6.4)$$

The exact system response is calculated with:

$$\mathbf{x}(t) = \Phi(t, t_0) \mathbf{x}_0 + \int_{t_0}^t \Phi(t, \tau) \mathbf{B} \mathbf{u}(\tau) d\tau, \quad (6.5)$$

with

$$\mathbf{x}_0 = \mathbf{x}(t_0), \quad (6.6)$$

and,

$$\Phi(t, t_0) = e^{\mathbf{A}(t-t_0)}. \quad (6.7)$$

To calculate the transient system response without damping, the resistances are assumed to be zero. Hence, the equation is simplified to:

$$\underbrace{\frac{d}{dt} \begin{bmatrix} i_{s,d}(t) \\ i_{s,q}(t) \\ i_f(t) \end{bmatrix}}_{\frac{d}{dt} \mathbf{x}(t)} = \underbrace{\begin{bmatrix} 0 & -L_f L_{s,q} \omega_{r,el} / \gamma & 0 \\ -L_{s,d} \omega_{r,el} / L_{s,q} & 0 & -M_{fs} \omega_{r,el} / L_{s,q} \\ 0 & M_{fs} L_{s,q} \omega_{r,el} / \gamma & 0 \end{bmatrix}}_{\mathbf{A}} \underbrace{\begin{bmatrix} i_{s,d}(t) \\ i_{s,q}(t) \\ i_f(t) \end{bmatrix}}_{\mathbf{x}(t)} + \underbrace{\begin{bmatrix} -L_f / \gamma & 0 & M_{fs} / \gamma \\ 0 & 1 / L_{s,q} & 0 \\ M_{fs} / \gamma & 0 & -L_{s,d} / \gamma \end{bmatrix}}_{\mathbf{B}} \underbrace{\begin{bmatrix} u_{s,d}(t) \\ u_{s,q}(t) \\ u_f(t) \end{bmatrix}}_{\mathbf{u}(t)}. \quad (6.8)$$

The eigenvalues of \mathbf{A} are determined by:

$$\begin{aligned} \det \left(\begin{bmatrix} \lambda & L_f L_{s,q} \omega_{r,el} / \gamma & 0 \\ L_{s,d} \omega_{r,el} / L_{s,q} & \lambda & M_{fs} \omega_{r,el} / L_{s,q} \\ 0 & -M_{fs} L_{s,q} \omega_{r,el} / \gamma & \lambda \end{bmatrix} \right) &= 0 \\ &= \lambda^3 + \frac{M_{fs} \omega_{r,el}^2}{\gamma} \lambda - \frac{L_f L_{s,d} \omega_{r,el}^2}{\lambda} \gamma \\ &= \lambda \left(\lambda^2 + \frac{\omega_{r,el}^2}{\gamma} M_{fs}^2 - L_f L_{s,d} \right). \end{aligned} \quad (6.9)$$

This results in the following eigenvalues, $\lambda_{1,2,3} = \{+j\omega_{r,el}, -j\omega_{r,el}, 0\}$.

The following transition matrix results from the calculated eigenvalues

$$\Phi(t, t_0) = e^{\mathbf{A}(t-t_0)} = \mathbf{P} \text{diag} \left(e^{\lambda_1(t-t_0)}, \dots, e^{\lambda_n(t-t_0)} \right) \mathbf{P}^{-1}, \quad (6.10)$$

with \mathbf{P} and \mathbf{P}^{-1} holding the left and right eigenvectors of \mathbf{A} leading to

$$\begin{aligned} \Phi(t, t_0) &= \begin{bmatrix} \frac{-M_{fs}}{L_{s,d}} & \frac{-L_f}{M_{fs}} & \frac{-L_f}{M_{fs}} \\ 0 & \frac{-j\gamma}{(L_{s,d}M_{fs})} & \frac{j\gamma}{(L_{s,q}M_{fs})} \\ 1 & 1 & 1 \end{bmatrix} \begin{bmatrix} e^{0(t-t_0)} & 0 & 0 \\ 0 & e^{-j\omega_{r,el}(t-t_0)} & 0 \\ 0 & 0 & e^{j\omega_{r,el}(t-t_0)} \end{bmatrix} \\ &= \begin{bmatrix} \frac{-M_{fs}L_{s,d}}{\gamma} & 0 & \frac{-L_fL_{s,d}}{\gamma} \\ \frac{M_{fs}L_{s,d}}{2\gamma} & \frac{jL_{s,q}M_{fs}}{2\gamma} & \frac{M_{fs}^2}{2\gamma} \\ \frac{M_{fs}L_{s,d}}{2\gamma} & \frac{-jL_{s,q}M_{fs}}{2\gamma} & \frac{M_{fs}^2}{2\gamma} \end{bmatrix} \\ &= \begin{bmatrix} \frac{M_{fs}^2 - L_{s,d}L_f \cos((t-t_0)\omega_{r,el})}{\gamma} & \frac{-L_{s,q}L_f \sin((t-t_0)\omega_{r,el})}{\gamma} & \frac{-L_fM_{fs}(\cos((t-t_0)\omega_{r,el})-1)}{\gamma} \\ \frac{-L_{s,d} \sin((t-t_0)\omega_{r,el})}{L_{s,q}} & \cos((t-t_0)\omega_{r,el}) & \frac{-M_{fs} \sin((t-t_0)\omega_{r,el})}{L_{s,q}} \\ \frac{L_{s,d}M_{fs}(\cos((t-t_0)\omega_{r,el})-1)}{\gamma} & \frac{L_{s,q}M_{fs} \cos((t-t_0)\omega_{r,el})}{\gamma} & \frac{M_{fs}^2 \cos((t-t_0)\omega_{r,el}) - L_{s,d}L_f}{\gamma} \end{bmatrix}. \end{aligned} \quad (6.11)$$

In the task, the short circuit case of the machine is given, therefore, the input voltage is zero, which leads to

$$\begin{bmatrix} i_{s,d}(t) \\ i_{s,q}(t) \\ i_f(t) \end{bmatrix} = \mathbf{x}(t) = \Phi(t, t_0)\mathbf{x}_0 + \underbrace{\int_{t_0}^t \Phi(t, \tau)\mathbf{B}\mathbf{u}(\tau)d\tau}_0, \quad (6.12)$$

and the given assumption for the initial states:

$$\mathbf{x}_0 = \begin{bmatrix} 0 \\ 0 \\ i_{f,0} \end{bmatrix}. \quad (6.13)$$

This results into the analytical solution:

$$\begin{aligned} \begin{bmatrix} i_{s,d}(t) \\ i_{s,q}(t) \\ i_f(t) \end{bmatrix} &= \begin{bmatrix} \frac{M_{fs}^2 - L_{s,d}L_f \cos(t\omega_{r,el})}{\gamma} & \frac{-L_{s,q}L_f \sin(t\omega_{r,el})}{\gamma} & \frac{-L_fM_{fs}(\cos(t\omega_{r,el})-1)}{\gamma} \\ \frac{-L_{s,d} \sin(t\omega_{r,el})}{L_{s,q}} & \cos(t\omega_{r,el}) & \frac{-M_{fs} \sin(t\omega_{r,el})}{L_{s,q}} \\ \frac{L_{s,d}M_{fs}(\cos(t\omega_{r,el})-1)}{\gamma} & \frac{L_{s,q}M_{fs} \cos(t\omega_{r,el})}{\gamma} & \frac{M_{fs}^2 \cos(t\omega_{r,el}) - L_{s,d}L_f}{\gamma} \end{bmatrix} \begin{bmatrix} 0 \\ 0 \\ i_{f0} \end{bmatrix} \\ &= \begin{bmatrix} \frac{-L_fM_{fs}(\cos(t\omega_{r,el})-1)}{\gamma} \\ \frac{-M_{fs} \sin(t\omega_{r,el})}{L_{s,q}} \\ \frac{M_{fs}^2 \cos(t\omega_{r,el}) - L_{s,d}L_f}{\gamma} \end{bmatrix} i_{f0}. \end{aligned} \quad (6.14)$$

1.2 Determine the maximum current $|i_{s,dq}|$ for this scenario.

Answer:

The quadratic current amplitude is given with:

$$i_{s,dq}^2(t) = i_{s,d}^2(t) + i_{s,q}^2(t) = i_{f0}^2 M_{fs}^2 \left(\frac{L_f^2}{\gamma^2} (\cos(t\omega_{r,el}) - 1)^2 + \frac{1}{L_{s,q}^2} \sin(t\omega_{r,el})^2 \right). \quad (6.15)$$

To determine the maximum current, the first derivative is calculated and set to zero, which is given as:

$$\frac{d}{dt} i_{s,dq}^2(t) = i_{f0} M_{fs}^2 \omega_{r,el} \underbrace{\left(-2 \frac{L_f^2}{\gamma^2} \sin(t\omega_{r,el}) (\cos(t\omega_{r,el}) - 1) + \frac{1}{L_{s,q}^2} \cos(t\omega_{r,el}) \sin(t\omega_{r,el}) \right)}_{t_{dq}^*} = 0. \quad (6.16)$$

In the next step, the value of t_{dq}^* is determined, so that the expression inside the brackets is zero. Hence, the maximum t_{dq}^* is calculated with:

$$t_{dq}^* = \arg \max_t i_{s,dq}(t) = \frac{1}{\omega_{r,el}} \arccos \left(\frac{L_f^2 L_{s,q}^2}{L_f^2 L_{s,q}^2 - \gamma^2} \right) + \frac{2\pi}{\omega_{r,el}} i, \quad (6.17)$$

for $i = 0, 1, 2, \dots$. This leads to the maximum current amplitude of:

$$i_{s,dq} = \frac{i_{f0} M_{fs} |\gamma|}{L_{s,q} \sqrt{\gamma^2 - L_f^2 L_{s,q}^2}} = 683 \text{ A}. \quad (6.18)$$

1.3 Write a Jupyter notebook to simulate the short transient response of the machine under the same initial conditions using an ODE solver. Compare the result including the impact of the stator resistance with the simplified analytical solution from the previous task. The simulation configuration is given in Tab. 6.2.

Table 6.2: Configuration of the simulation.

Symbol	Description	Value
T_{sim}	Simulation time	0.05 s
$\varepsilon_{m,0}$	Start angle of the rotor	0°
$\omega_{m,0}$	Start speed of the rotor	628.3 $\frac{1}{s}$

Answer:

Beside the stator current ODEs, the mechanical system of the machine must be considered, therefore, the generated torque is calculated with

$$T(t) = \frac{3}{2} p (M_{fs} i_f(t) + (L_{s,d} - L_{s,q}) i_{s,q}(t) i_{s,d}(t)), \quad (6.19)$$

and the mechanical equation is defined as follows:

$$\frac{d}{dt}\omega(t) = \frac{p}{J} (T(t) - T_1(t)). \quad (6.20)$$

The relationship between the angle and the rotational speed is given by:

$$\frac{d}{dt}\varepsilon(t) = \omega(t). \quad (6.21)$$

In Sol.-Fig. 6.1 a comparison between the analytical and the numerical solution of is shown. The currents are initialized with the same values at $t = 0$. The trajectories of the analytical and the numerical current values are identical, except that a damping behavior is visible in the numerical solution. This results from the consideration of the winding resistances in the numerical solution, in comparison to the simplified analytical one.

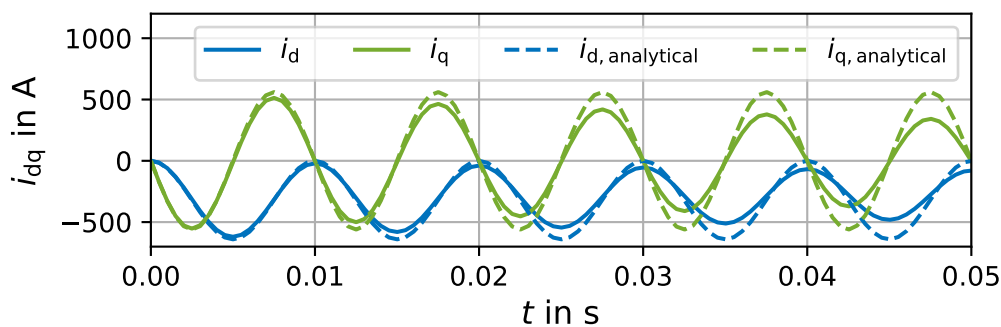

Solution Figure 6.1: Transient process of i_{dq} of a salient synchronous machine with a stator and field winding short circuit.

The trajectories of the field current i_f are visualized in Sol.-Fig. 6.2. The behavior of this two trajectories are identical, except to the damping in the numerical solution, due to the considered winding resistance.

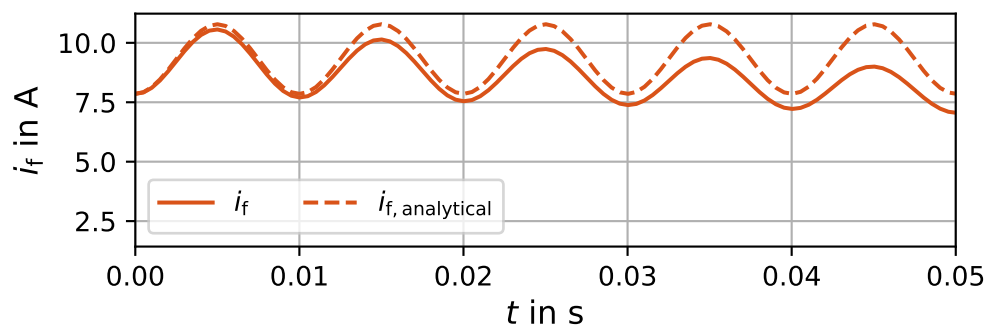

Solution Figure 6.2: Transient process of the field current i_f of a salient synchronous machine with a stator and field winding short circuit.

1.4 Add a load with the following characteristic $T_1(t) = 0.0001 \cdot \omega_r^2(t)$ to the existing simulation. Repeat the simulation with the same initial conditions as in the task before. Extend the simulation

time to $T_{\text{sim}} = 0.5$ s and plot the currents $i_d(t)$, $i_f(t)$, the angular frequency of the rotor $\omega_{r,\text{el}}(t)$ and the torque $T(t)$.

Answer:

The resulting currents for the new operating point are shown in Sol.-Fig. 6.3.

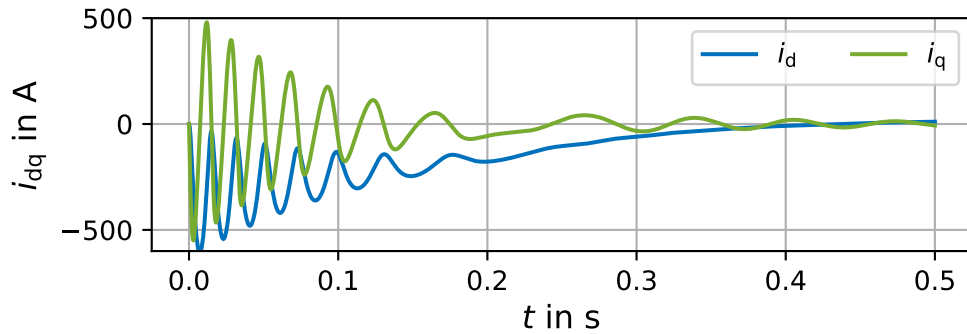

Solution Figure 6.3: Transient process of i_{dq} of a salient synchronous machine with a stator and field winding short circuit and a load resistance.

The field winding current is visualized in Sol.-Fig. 6.4.

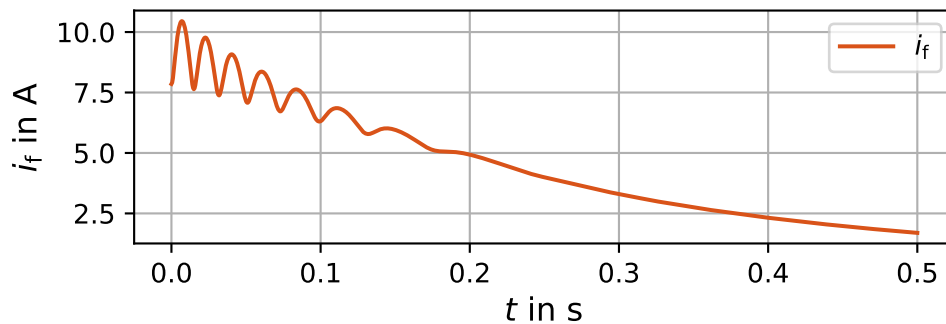

Solution Figure 6.4: Transient process of i_f of a salient synchronous machine with a stator and field winding short circuit and a load resistance.

Fig 6.5 shows the angular frequency of the rotor. Due to the winding resistance and the additional load, the currents are reduced over time, until the machine comes to a standstill.

The generated torque during the transient process is shown in Sol.-Fig. 6.6.

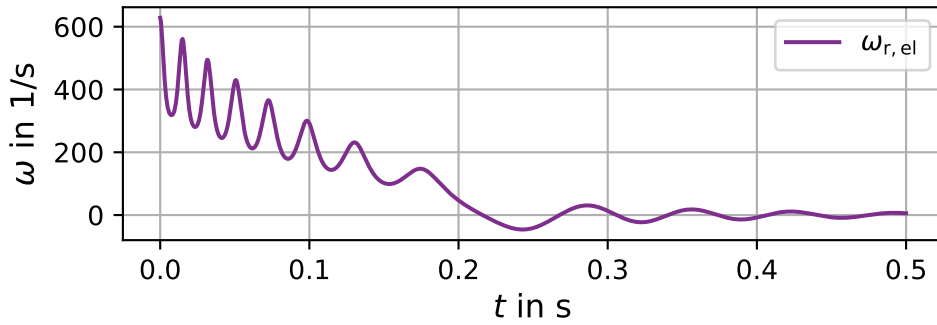

Solution Figure 6.5: Transient process of a salient synchronous machine with a stator and field winding short circuit and a load resistance.

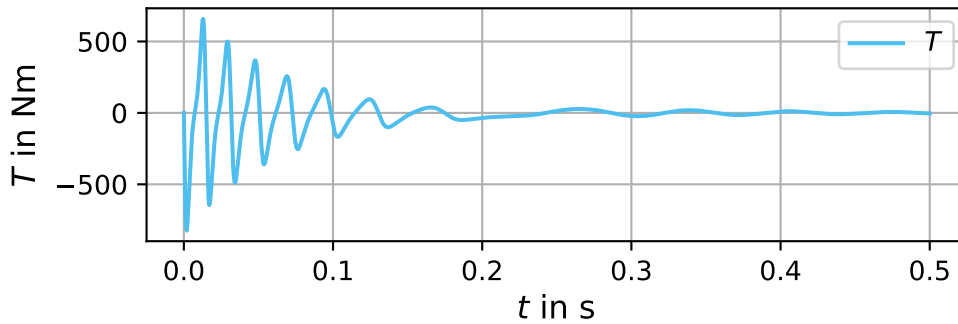

Solution Figure 6.6: Generated torque of a salient synchronous machine with a stator and field winding short circuit and a load resistance.

1.5 Now consider an additional damper winding with the parameters from Tab. 6.3 in the simulation. Compare the resulting current signalforms, the speed and the generated torque to the previous tasks with the identical simulation configuration as in the previous tasks. Consider the damper winding to not carry any current for $t = 0$.

Table 6.3: Parameters of the damper winding.

Symbol	Description	Value
M_{dD}	Mutual ind. rotor d-axis	2 mH
M_{qQ}	Mutual ind. rotor q-axis	1 mH
M_{fr}	Mutual ind. field-rotor	50 mH
L_D	Self ind. rotor d-axis	3 mH
L_Q	Self ind. rotor q-axis	2 mH
R_{rD}	Rotor winding res. d-axis	50 mΩ
R_{rQ}	Rotor winding res. q-axis	30 mΩ

Answer:

With the additional damper winding, the stator flux linkage equation extends to

$$\begin{bmatrix} \psi_{s,d}(t) \\ \psi_{s,q}(t) \end{bmatrix} = \begin{bmatrix} L'_{s,d} & 0 \\ 0 & L'_{s,q} \end{bmatrix} \begin{bmatrix} i_{s,d}(t) \\ i_{s,q}(t) \end{bmatrix} + M_{fs} \begin{bmatrix} 1 \\ 0 \end{bmatrix} i_f(t) + \begin{bmatrix} M_{dD} & 0 \\ 0 & M_{qQ} \end{bmatrix} \begin{bmatrix} i_{r,D}(t) \\ i_{r,Q}(t) \end{bmatrix}, \quad (6.22)$$

and the field flux equation is extended with the rotor current as follows:

$$\psi_f(t) = L_f i_f(t) + M_{f,s} \begin{bmatrix} 1 & 0 \end{bmatrix} \begin{bmatrix} i_{s,d}(t) \\ i_{s,q}(t) \end{bmatrix} + M_{fr} \begin{bmatrix} 1 & 0 \end{bmatrix} \begin{bmatrix} i_{r,D}(t) \\ i_{r,Q}(t) \end{bmatrix}. \quad (6.23)$$

The rotor flux equation is defined by:

$$\begin{bmatrix} \psi_{r,D} \\ \psi_{r,Q} \end{bmatrix} = \begin{bmatrix} L_{s,d} & 0 \\ 0 & L_{s,q} \end{bmatrix} \begin{bmatrix} i_{r,D}(t) \\ i_{r,Q}(t) \end{bmatrix} + \begin{bmatrix} M_{dD} & 0 \\ 0 & M_{qQ} \end{bmatrix} \begin{bmatrix} i_{s,d}(t) \\ i_{s,q}(t) \end{bmatrix} + M_{fr} \begin{bmatrix} 1 \\ 0 \end{bmatrix} i_f(t). \quad (6.24)$$

In addition, also the torque equation changes to:

$$T(t) = \frac{3}{2}p \left[M_{fs} i_f i_{s,q} + (L'_{s,d} - L'_{s,q}) i_{s,d} i_{s,q} + M_{dD} i_{s,q} i_{r,D} - M_{qQ} i_{s,d} i_{r,Q} \right]. \quad (6.25)$$

For the SM with damper winding, the flux linkage matrix extends to:

$$\boldsymbol{\psi} = \begin{bmatrix} \psi_{s,d}(t) \\ \psi_{s,q}(t) \\ \psi_f(t) \\ \psi_{r,D}(t) \\ \psi_{r,Q}(t) \end{bmatrix} = \underbrace{\begin{bmatrix} L'_{s,d} & 0 & M_{fs} & M_{dD} & 0 \\ 0 & L'_{s,q} & 0 & 0 & M_{qQ} \\ M_{fs} & 0 & L_f & M_{fr} & 0 \\ M_{dD} & 0 & M_{fr} & L_D & 0 \\ 0 & M_{qQ} & 0 & 0 & L_Q \end{bmatrix}}_{\mathbf{L}} \begin{bmatrix} i_{s,d}(t) \\ i_{s,q}(t) \\ i_f(t) \\ i_{r,D}(t) \\ i_{r,Q}(t) \end{bmatrix}. \quad (6.26)$$

The differential current machine model with damping winding is defined as:

$$\frac{d}{dt} \begin{bmatrix} i_{s,d}(t) \\ i_{s,q}(t) \\ i_f(t) \\ i_{r,D}(t) \\ i_{r,Q}(t) \end{bmatrix} = \mathbf{L}^{-1} \left(\begin{bmatrix} u_{s,d}(t) \\ u_{s,q}(t) \\ u_f(t) \\ u_{r,D}(t) \\ u_{r,Q}(t) \end{bmatrix} - \begin{bmatrix} R_s & 0 & 0 & 0 & 0 \\ 0 & R_s & 0 & 0 & 0 \\ 0 & 0 & R_f & 0 & 0 \\ 0 & 0 & 0 & R_{r,D} & 0 \\ 0 & 0 & 0 & 0 & R_{r,Q} \end{bmatrix} \begin{bmatrix} i_{s,d}(t) \\ i_{s,q}(t) \\ i_f(t) \\ i_{r,D}(t) \\ i_{r,Q}(t) \end{bmatrix} - \begin{bmatrix} 0 & -\omega_{r,el}(t) & 0 & 0 & 0 \\ \omega_{r,el}(t) & 0 & 0 & 0 & 0 \\ 0 & 0 & 0 & 0 & 0 \\ 0 & 0 & 0 & 0 & 0 \\ 0 & 0 & 0 & 0 & 0 \end{bmatrix} \begin{bmatrix} i_{s,d}(t) \\ i_{s,q}(t) \\ i_f(t) \\ i_{r,D}(t) \\ i_{r,Q}(t) \end{bmatrix} \right). \quad (6.27)$$

In Sol.-Fig. 6.7 the i_{dq} current trajectories during the transient process are shown.

The field current is visualized in Sol.-Fig. 6.8.

The rotational speed of the rotor is shown in Sol.-Fig. 6.9. The steady state is reached faster than in the simulation before, due to the added damping winding.

Sol.-Fig. 6.10 shows the generated torque during the transient process. The faster transient process is also visible in the torque curve, which faster converts to zero.

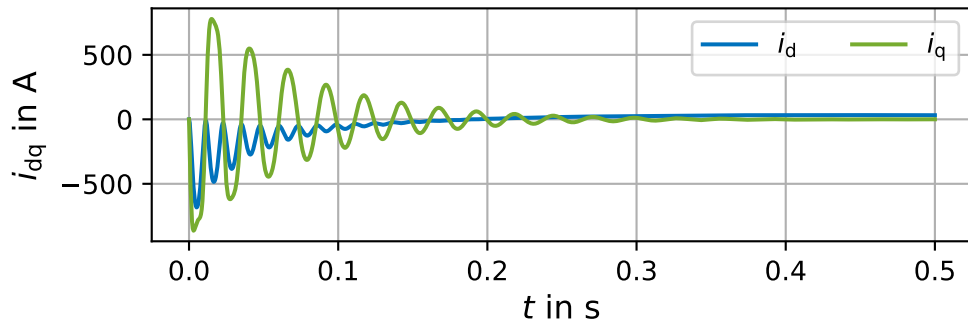

Solution Figure 6.7: Transient process of a salient synchronous machine with a stator and field winding short circuit and a damper winding.

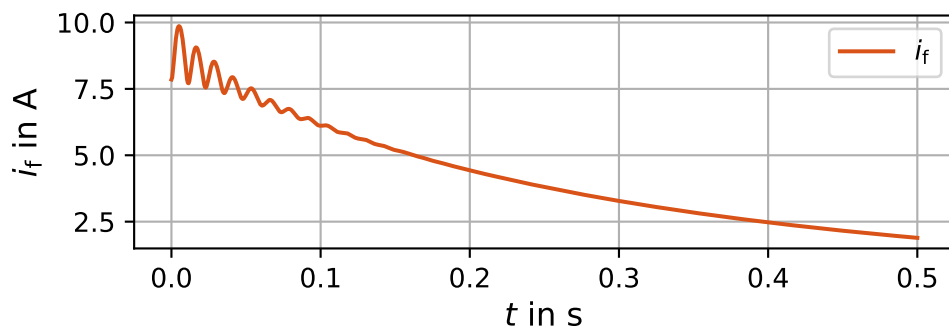

Solution Figure 6.8: Field current of a salient synchronous machine with a stator and field winding short circuit and a damper winding.

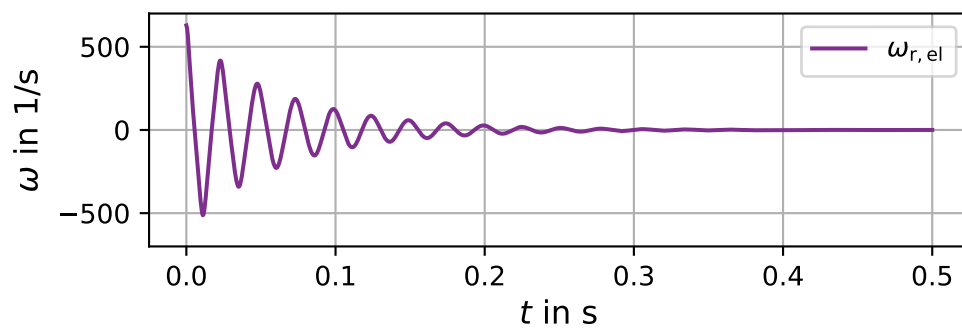

Solution Figure 6.9: Speed of a salient synchronous machine with a stator and field winding short circuit and a damper winding.

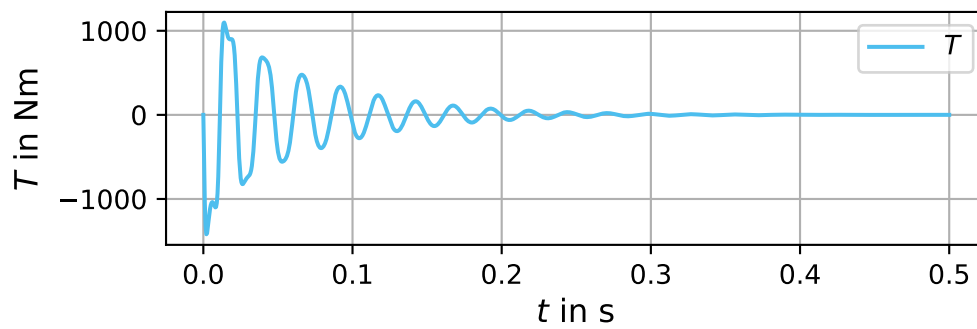

Solution Figure 6.10: Torque of a salient synchronous machine with a stator and field winding short circuit and a damper winding.

Task 2: Cylindrical synchronous machine

In a thermal power station, a cylindrical synchronous generator is used which has the rated data in Tab. 6.4 and is connected in star. The generator is driven by a turbine. The converted energy is fed into the 50 Hz national grid via a transformer. Saturation effects and losses in the machine can be neglected.

Table 6.4: Parameters of the synchronous machine.

Symbol	Description	Value
$U_{star,n}$	Star voltage	$\frac{10}{\sqrt{3}}$ kV
$I_{star,n}$	Star current	6500 A
f_n	Nominal frequency	50 Hz
$\cos(\varphi_n)$	Power factor	0.8 (capacitive)
n_n	Nominal speed	$1500 \frac{1}{min}$
$I_{f,n}$	Field current	150 A
$I_{s,sc0}$	Short circuit current	7800 A

2.1 Synchronization must be carried out to connect the synchronous generator to the electricity grid. Why is this process necessary? Name the synchronization conditions that must be checked before the generator can be connected to the grid.

Answer:

Necessity of synchronization:

- Synchronization of the generator with the grid is absolutely essential for a complication-free connection of the machine to the grid. Otherwise, severe transient effects can lead to catastrophic effects.
- A high phase shift during the synchronization can start the machine to oscillate, but this is reduced by the damper winding in the rotor.
- In addition, connecting the generator with a large phase offset leads to high equalizing currents and thus a large torque are the result, which leads to the destruction of the generator.

Therefore, the following synchronization conditions should be fulfilled:

- The rotational frequency is equal to the grid frequency.
- The terminal voltage and the grid voltage are at the same level.
- The sense of rotation of the machine is equal to the grid.
- The phase orientation is equal to the grid.

2.2 How can the amount of active power output be influenced during generator operation? On the other hand, how can the inductive reactive power delivered or absorbed be influenced?

Answer:

The delivered active power can only be influenced by changing the mechanical input power. The delivered (over excitation) or absorbed (under excitation) reactive power is controlled via the field current.

2.3 What is meant by synchronous condenser operation?

Answer:

In the synchronous condenser operation mode, only reactive power is delivered into or absorbed from the grid. The machine operates in no-load mode. This operation mode is used to control the reactive power within the grid. Sometimes, more or less reactive power is needed, dependant on the conditions of the considered time frame.

2.4 Calculate with the given data the pole pair number p , the synchronous reactance X_s , the apparent power S , the phase shift angle φ , the inner voltage U_i and the load angle θ at the rated conditions.

Answer:

The pole pair number is determined with:

$$p = \frac{\omega_n}{\omega_{\text{mech}}} = \frac{2\pi \cdot 50 \frac{1}{\text{s}}}{2\pi \cdot 25 \frac{1}{\text{s}}} = 2. \quad (6.28)$$

The synchronous reactance is calculated by

$$X_s = \frac{U_s}{I_{s,\text{sc0}}} = \frac{\frac{10000}{\sqrt{3}} \text{ V}}{7800 \text{ A}} = 0.74 \Omega, \quad (6.29)$$

with the stator voltage U_s and the short circuit current $I_{s,\text{sc0}}$. The apparent power determines as

$$S = \sqrt{3}U_n I_n = \sqrt{3} \cdot 10000 \text{ V} \cdot 6500 \text{ A} = 112.58 \text{ MVA}, \quad (6.30)$$

and this leads to the calculation of the phase shift angle by:

$$\varphi = \arccos(-0.8) \cdot \text{sign}\left(\frac{Q}{S}\right) = -\arccos(-0.8) = -143.13^\circ. \quad (6.31)$$

The inner voltage is calculated with

$$U_i = X_s I_{s,\text{sc}} = X_s \left(\frac{I_{s,\text{sc0}} - I_s \sin(\varphi)}{\cos(\varphi)} \right), \quad (6.32)$$

and the active power is defined as:

$$P = \frac{3U_s U_i}{X_s} \sin(\theta). \quad (6.33)$$

Inserting the inner voltage from above into the active power equation, yields:

$$P = \frac{3U_s X_s \left(\frac{I_{s,sc0} - I_s \sin(\varphi)}{\cos(\varphi)} \right)}{X_s} \sin(\theta) = 3U_s (I_{s,sc0} - I_s \sin(\varphi)) \tan(\theta). \quad (6.34)$$

Hence, the load angle is determined with resorting the equation from above as follows:

$$\begin{aligned} \theta &= \arctan \left(\frac{P}{3U_s (I_{s,sc0} - I_s \sin(\varphi))} \right) = \arctan \left(\frac{3U_s I_s \cos(\varphi)}{3U_s (I_{s,sc0} - I_s \sin(\varphi))} \right) \\ &= \arctan \left(\frac{I_s \cos(\varphi)}{I_{s,sc0} - I_s \sin(\varphi)} \right) = \arctan \left(\frac{6.5 \text{ kA} \cdot \cos(-143.13^\circ)}{7.8 \text{ kA} - 6.5 \text{ kA} \cdot \sin(-143.13^\circ)} \right) = -23.95^\circ. \end{aligned} \quad (6.35)$$

The inner voltage is calculated by:

$$U_i = X_s I_{s,sc} = X_s \left(\frac{I_{s,sc0} - I_s \sin(\varphi)}{\cos(\theta)} \right) = 0.74 \Omega \cdot \left(\frac{7.8 \text{ kA} - 6.5 \text{ kA} \cdot \sin(-143.13^\circ)}{\cos(-23.95^\circ)} \right) = 9473 \text{ V}. \quad (6.36)$$

2.5 The generator should only take reactive power from the grid. How large is the stator current I_s and the field current I_f at this operating point, when a reactive power of 120 MVA is extracted from the grid? How large is the phase shift angle φ and the load angle θ ? Draw the phasor diagram for this operating point.

Answer:

The stator current changes to

$$I_s = \frac{Q}{\sqrt{3}U_n \sin(\varphi)} = \frac{120 \text{ MVA}}{\sqrt{3} \cdot 10 \text{ kV}} = 6928.2 \text{ A}, \quad (6.37)$$

and the inner voltage is determined with:

$$U_i = \frac{3U_s^2 - X_s Q}{3U_s \cos(\theta)} = \frac{3 \cdot \left(\frac{10 \text{ kV}}{\sqrt{3}} \right)^2 - 0.74 \Omega \cdot 120 \text{ MVA}}{3 \cdot \frac{10 \text{ kV}}{\sqrt{3}} \cos(0^\circ)} = 1501.11 \text{ V}. \quad (6.38)$$

Therefore, the necessary field current results in

$$I_f = \frac{U_i}{U_{i,n}} I_{f,n} = \frac{1501.11 \text{ V}}{9473 \text{ V}} \cdot 150 \text{ A} = 23.77 \text{ A}. \quad (6.39)$$

The phase shift angle is $\varphi = 90^\circ$ and the load angle is $\theta = 0^\circ$. The phasor diagram is visualized in Sol.-Fig. 6.11, the inner voltage \underline{U}_i is purely imaginary, as defined in the lecture notes. The stator voltage \underline{U}_s and the internal voltage are directly on top of each other due to the zero load angle θ .

2.6 In contrast to the previous subtask, the generator should provide 80 MW in addition to the reactive power now. How large is the stator current I_s , the phase shift angle φ and the load angle θ ? Draw also for this operation point the phasor diagram.

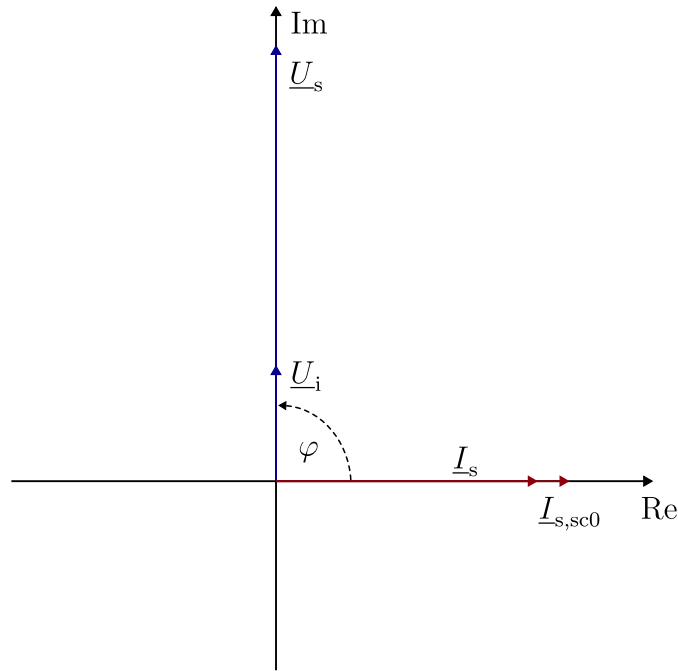

Solution Figure 6.11: Phasor diagram for the given operating point. The scala is for the voltage 1 cm $\hat{=}$ 1000 V and for the current 1 cm $\hat{=}$ 2000 A.

Answer:

The apparent power is:

$$S = \sqrt{P^2 + Q^2} = \sqrt{(80 \text{ MW})^2 + (120 \text{ MVA})^2} = 144.22 \text{ MVA}. \quad (6.40)$$

Hence, the stator current yields:

$$I_s = \frac{S}{\sqrt{3}U_n} = \frac{144.22 \text{ MVA}}{\sqrt{3} \cdot 10 \text{ kV}} = 8326.54 \text{ A}. \quad (6.41)$$

Retrieving the power factor via the complex power equation leads to:

$$\varphi = \arccos\left(\frac{-P}{\sqrt{3}U_{s,n}I_s}\right) = \arccos\left(\frac{-80 \text{ MW}}{\sqrt{3} \cdot 10 \text{ kV} \cdot 8326.54 \text{ A}}\right) = 123.7^\circ. \quad (6.42)$$

The derivation of the load angle is already given in (6.35), which results for the new operation point in

$$\theta = \arctan\left(\frac{I_s \cos(\varphi)}{I_{s,sc0} - I_s \sin(\varphi)}\right) = -79.66^\circ, \quad (6.43)$$

while the resulting inner voltage is

$$U_i = X_s I_{s,sc} = 3600 \text{ V}. \quad (6.44)$$

The phasor diagram is visualized in Sol.-Fig. 6.12, the inner voltage \underline{U}_i is purely imaginary, as defined

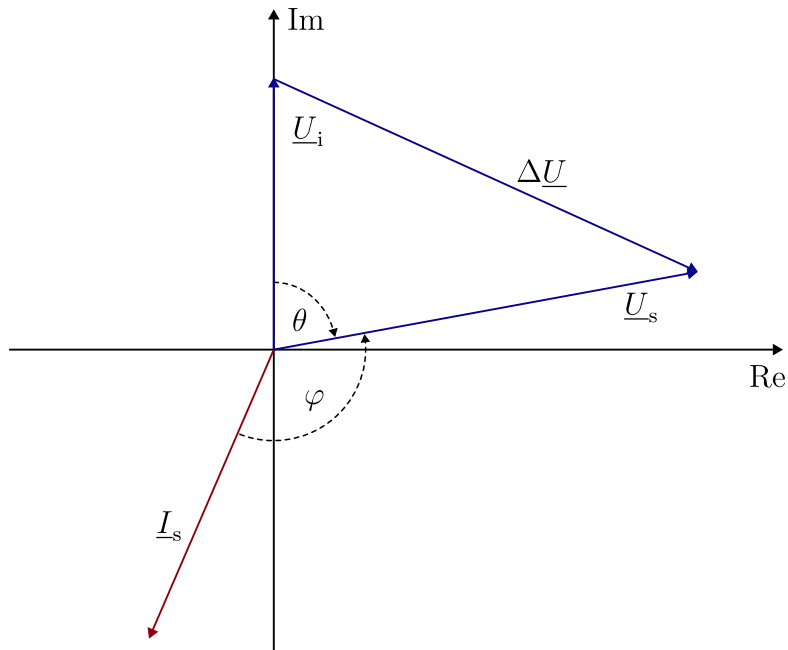

Solution Figure 6.12: Phasor diagram for the given operating point. The scala is for the voltage 1 cm \cong 1000 V and for the current 1 cm \cong 2000 A.

in the lecture notes.

2.7 Now, the generator should provide a reactive power of 60 MVA into the grid. How large is the generated torque T , that the generator operates within the rated apparent power? To which value must the field current I_f change, such that the rated current is reached in the stator winding?

Answer:

With the determined rated apparent power in the task before, the given reactive power, the maximum power is calculated by

$$P = \sqrt{S_n^2 - Q^2} = \sqrt{(112.58 \text{ MVA})^2 - (60 \text{ MVA})^2} = 95.26 \text{ MW}, \tag{6.45}$$

hence, the maximum torque is given with:

$$T_{\max} = \frac{P}{\omega_{\text{mech},n}} = \frac{95.26 \text{ MW}}{2\pi \cdot 25 \frac{1}{s}} = 606.5 \text{ kNm}. \tag{6.46}$$

The angle φ for the phase shift at nominal current is determined as:

$$\varphi = \arccos\left(\frac{P}{\sqrt{3}U_{\text{star},n}I_{\text{star},n}}\right) = \arccos\left(\frac{-95.26 \text{ MW}}{\sqrt{3} \cdot 10 \text{ kV} \cdot 6.5 \text{ kA}}\right) = -147.8^\circ. \tag{6.47}$$

With (6.35) the load angle is calculated by

$$\theta = \arccos\left(\frac{I_s \cos(\varphi)}{I_{s,sc0} - I_{s,sc} \sin(\varphi)}\right) = \arctan\left(\frac{6.5 \text{ kA} \cos(-147.8^\circ)}{7.8 \text{ kA} - 6.5 \text{ kA} \sin(-147.8^\circ)}\right) = -26.03^\circ, \tag{6.48}$$

therefore, the inner voltage results into:

$$U_i = X_s I_{s,sc} = X_s \left(\frac{I_{s,sc0} - I_s \sin(\varphi)}{\cos(\theta)} \right) = 0.74 \, \Omega \left(\frac{7.8 \, \text{kA} - 6.5 \, \text{kA} \sin(-147.8^\circ)}{\cos(-26.03^\circ)} \right) = 9276 \, \text{V}. \quad (6.49)$$

The field current must be set to the following value:

$$I_f = \frac{U_i}{U_{i,n}} I_{f,n} = \frac{9276 \, \text{V}}{9473 \, \text{V}} \cdot 150 \, \text{A} = 146.9 \, \text{A}. \quad (6.50)$$

Task 3: Steady-state operation of a synchronous machine

Consider a loss-free synchronous machine with the parameters from Tab. 6.5. First, the synchronous machine is operated as a motor. Using the data given above, determine the following characteristic variables of the synchronous machine at rated operation. An example phasor diagram for this operation is shown in Fig. 6.1.

Table 6.5: Parameters of the synchronous machine.

Symbol	Description	Value
$U_{\text{star},n}$	Star voltage	$\frac{6}{\sqrt{3}}$ kV
$I_{\text{star},n}$	Star current	96 A
f_n	Nominal frequency	50 Hz
p	Pole pair number	2
$\cos(\varphi_n)$	Power factor	0.9 (capacitive)
T_n	Nominal torque	$\frac{T_{\text{max}}}{2}$

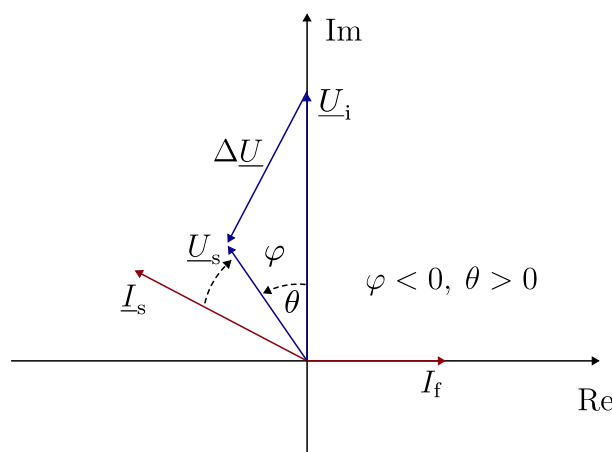

Figure 6.1: Phasor diagram of a over excited synchronous machine in motor mode.

3.1 How large is the maximum torque T_{max} ?

which leads to the angle:

$$\theta = \arcsin\left(\frac{I_s}{I_{s,sc}}\right) \cos(\varphi) = \arcsin\left(\frac{96 \text{ A}}{172.8 \text{ A}}\right) \cdot 0.9 = 30^\circ. \tag{6.54}$$

3.3 Determine the synchronous reactance X_s value.

Answer:

The reactance is determined as:

$$\begin{aligned} X_s &= \frac{U_i}{I_{s,sc}} = \frac{U_s}{I_{s,sc0}} = \frac{U_s}{I_s \sin(\arccos(0.9)\text{sign}(Q/S)) + I_{s,sc} \cos(\theta)} \\ &= \frac{\frac{6000}{\sqrt{3}} \text{ V}}{96 \text{ A} \cdot \sin(-25.8^\circ) + 172.8 \text{ A} \cdot \cos(30^\circ)} = 32.12 \ \Omega. \end{aligned} \tag{6.55}$$

3.4 Calculate the inner voltage U_i at the nominal operating point.

Answer:

$$U_i = X_s I_{s,sc} = 32.12 \ \Omega \cdot 172.79 \text{ A} = 5549.52 \text{ V} \tag{6.56}$$

3.5 In the next task, the machine operates as generator and the power is 500 kW. The phasor diagram for this operation is shown in Fig. 6.2. Which load angle θ is set at the new operating point?

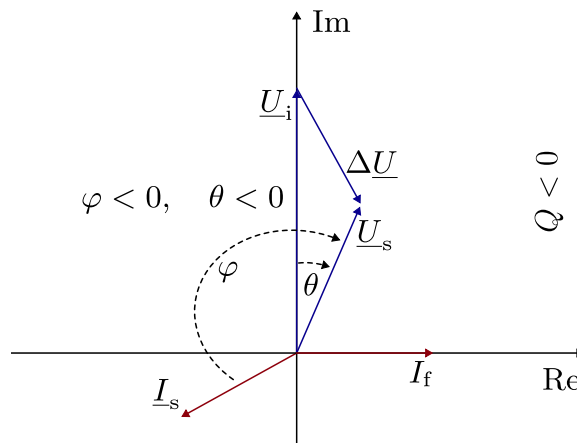

Figure 6.2: Phasor diagram of an over excited synchronous machine in generator mode.

Answer:

In the generator mode, the load angle is negative. With the generated power of 500 kW and the constant voltage, the product of the current and power factor is determined by:

$$\cos(\varphi) I_s = \frac{P}{3U_s} = \frac{-500 \text{ kW}}{3 \cdot \frac{6000}{\sqrt{3}} \text{ V}} = -48.11 \text{ A}. \tag{6.57}$$

It is also assumed that the short-circuit current has not changed its value by maintaining the excitation current. The load angle can now be determined using the trigonometric relationship:

$$\theta = \arcsin\left(\frac{I_s}{I_{s,sc}} \cos(\varphi)\right) = \arcsin\left(\frac{-48.11 \text{ A}}{172.8 \text{ A}}\right) = -16.17^\circ. \quad (6.58)$$

3.6 Calculate the stator current I_s .

Answer:

The stator current is calculated with the active and the reactive current components, which are defined as in the previous task by

$$I_s = \sqrt{I_{\text{active}}^2 + I_{\text{reactive}}^2} = \sqrt{(I_s \sin(-\varphi - 90^\circ))^2 + (I_s \cos(-\varphi - 90^\circ))^2}. \quad (6.59)$$

With the relationship between the trigonometric functions and the phase shift, the equation from above is resorted to:

$$\begin{aligned} I_s &= \sqrt{(-I_s \cos(-\varphi))^2 + (I_s \sin(-\varphi))^2} \\ &= \sqrt{(-I_s \cos(-\varphi))^2 + (-I_s \sin(\varphi))^2}. \end{aligned} \quad (6.60)$$

With the triangular relationship:

$$\begin{aligned} I_s &= \sqrt{(-I_s \cos(-\varphi))^2 + (I_{s,sc0} - I_{s,sc} \cos(\theta))^2} \\ &= \sqrt{(-I_s \cos(-\varphi))^2 + (I_{s,sc0} + I_{s,sc} \cos(\theta))^2}. \end{aligned} \quad (6.61)$$

Use the calculation of the short circuit current $I_{s,sc0}$, leads to:

$$\begin{aligned} I_s &= \sqrt{(-I_s \cos(-\varphi))^2 + \left(-\frac{U_s}{X_s} + I_{s,sc} \cos(\theta)\right)^2} \\ &= \sqrt{(48.11 \text{ A})^2 + \left(-\frac{6000}{\sqrt{3}} \text{ V} + 172.79 \text{ A} \cos(-16.17^\circ)\right)^2} \\ &= 75.44 \text{ A}. \end{aligned} \quad (6.62)$$

3.7 How large is the power factor $\cos(\varphi)$ at this operating point? In addition, calculate the angle φ .

Answer:

The active power is calculated with

$$I_{\text{active}} = I_s \cos(\varphi), \quad (6.63)$$

which then leads to

$$\cos(\varphi) = \frac{I_{\text{active}}}{I_s} = \frac{I_s \cos(\varphi)}{I_s} = \frac{-48.11 \text{ A}}{75.44 \text{ A}} = -0.638, \quad (6.64)$$

and, therefore, the angle results into:

$$\varphi = \arccos(-0.638) \cdot \text{sign}\left(\frac{Q}{S}\right) = -\arccos(-0.638) = -129.6^\circ. \quad (6.65)$$