

The Tau Manifesto

Michael Hartl

Tau Day, 2010

1 The circle constant

Welcome to the *Tau Manifesto*. This manifesto is dedicated to one of the most important numbers in mathematics, perhaps *the* most important: the *circle constant* relating the circumference of a circle to its linear dimension. For millennia, the circle has been considered the most perfect of shapes, and the circle constant captures the geometry of the circle in a single number. Of course, the traditional choice of circle constant is π —but, as mathematician [Bob Palais](#) notes in his delightful article “ π Is Wrong!”,¹ π is *wrong*. It’s time to set things right.

1.1 An immodest proposal

We begin repairing the damage wrought by π by first understanding the notorious number itself. The traditional definition for the circle constant sets π (pi) equal to the ratio of a circle’s circumference to its diameter:²

$$\pi \equiv \frac{C}{D} = 3.14159265\dots$$

The number π has many remarkable properties—among other things, it is *transcendental*, which means that it is also *irrational*—and its presence in mathematical formulas is widespread.

It should be obvious that π is not “wrong” in the sense of being factually incorrect; the number π is perfectly well-defined, and it has all the properties normally ascribed to it by mathematicians. When we say that “ π is wrong”, we mean that π is a *confusing and unnatural choice for the circle constant*. In particular, since a circle is most succinctly defined as the set of points a fixed distance—the *radius*—from a given point, a more natural definition for the circle constant uses r in place of D :

$$\text{circle constant} \equiv \frac{C}{r}.$$

Because the diameter of a circle is twice its radius, this number is numerically equal to 2π . Like π , it is transcendental and hence irrational, and (as we’ll see in [Section 2](#)) its use in mathematics is similarly widespread.

In “ π Is Wrong!”, Bob Palais argues persuasively in favor of the second of these two definitions for the circle constant, and in my view he deserves principal credit for identifying this issue and bringing it to a broad audience. He calls the true circle constant “one turn”, and he also introduces a new symbol to represent it ([Figure 1](#)). As we’ll see, the description is prescient, but unfortunately the symbol is rather strange, and (as discussed in [Section 4.2](#)) it seems unlikely to gain wide adoption.

¹Palais, Robert. “ π Is Wrong!”, *The Mathematical Intelligencer*, Volume 23, Number 3, 2001, pp. 7–8. Many of the arguments in the *Tau Manifesto* are based on or are inspired by “ π Is Wrong!”. It is available online at <http://bit.ly/pi-is-wrong>.

²The symbol \equiv means “is defined as”.

π

Figure 1: The strange symbol for the circle constant from “ π Is Wrong!”.

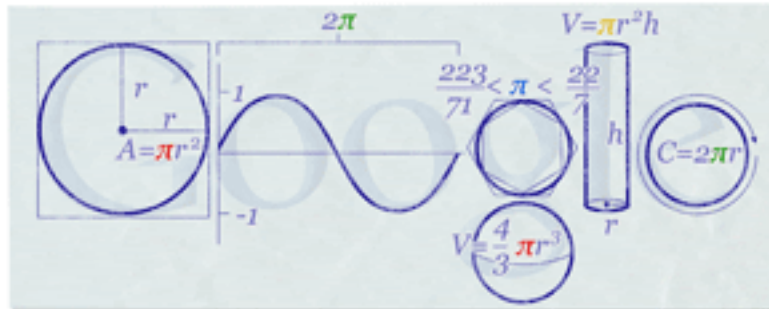

Figure 2: The Google logo on March 14 (3/14), 2010 (“Pi Day”).

The *Tau Manifesto* is dedicated to the proposition that the proper response to “ π is wrong” is “No, *really*.” And the true circle constant deserves a proper name. As you may have guessed by now, the *Tau Manifesto* proposes that this name should be the Greek letter τ (tau):

$$\tau \equiv \frac{C}{r} = 6.283185307179586 \dots$$

Throughout the rest of this manifesto, we will see that the *number* τ is the correct choice, and we will show through usage (Section 2 and Section 3) and by direct argumentation (Section 4) that the *letter* τ is a natural choice as well.

1.2 A powerful enemy

Before proceeding with the demonstration that τ is the natural choice for the circle constant, let us first acknowledge what we are up against—for there is a powerful conspiracy, centuries old, determined to propagate pro- π propaganda. Entire [books are written](#) extolling the virtues of π . (I mean, *books*!) And irrational devotion to π has spread even to the highest levels of geekdom; for example, on “Pi Day” 2010 [Google changed its logo](#) to honor π (Figure 2).

Meanwhile, some people memorize dozens, hundreds, even *thousands* of digits of this mystical number. What kind of sad sack memorizes even 50 digits of π (Figure 3)?³

³The video in Figure 3 (available at <http://vimeo.com/12914981>) is an excerpt from a lecture given by Dr. Sarah Greenwald, a professor of mathematics at [Appalachian State University](#). Dr. Greenwald uses math references from *The Simpsons* and *Futurama* to engage her students’ interest and to help them get over their math anxiety. She is also the maintainer of the [Futurama Math Page](#). (By the way, *Futurama* is back on the air! New episodes are currently airing Thursday nights on Comedy Central at 10/9c.)



Figure 3: Michael Hartl proves [Matt Groening](#) wrong by reciting π to 50 decimal places.

Truly, proponents of τ face a mighty opponent. And yet, we have a powerful ally—for the truth is on our side.

2 The number tau

We saw in [Section 1.1](#) that the number τ can also be written as 2π . As noted in “ π Is Wrong!”, it is therefore of great interest to discover that the combination 2π occurs with astonishing frequency throughout mathematics. For example, consider integrals over all angles in polar coordinates:

$$\int_0^{2\pi} \int_0^r f(r, \theta) dr d\theta.$$

The upper limit of the θ integration is always 2π . The same factor appears in the definition of the [Gaussian \(normal\) distribution](#),

$$\frac{1}{\sqrt{2\pi}\sigma} e^{-\frac{(x-\mu)^2}{2\sigma^2}},$$

and again in the [Fourier transform](#),

$$f(x) = \int_{-\infty}^{\infty} F(k) e^{2\pi i k x} dk$$

$$F(k) = \int_{-\infty}^{\infty} f(x) e^{-2\pi i k x} dx.$$

It recurs in [Cauchy’s integral formula](#),

$$f(a) = \frac{1}{2\pi i} \oint_{\gamma} \frac{f(z)}{z - a} dz,$$

in the n th [roots of unity](#),

$$z^n = 1 \Rightarrow z = e^{\frac{2\pi i}{n}},$$

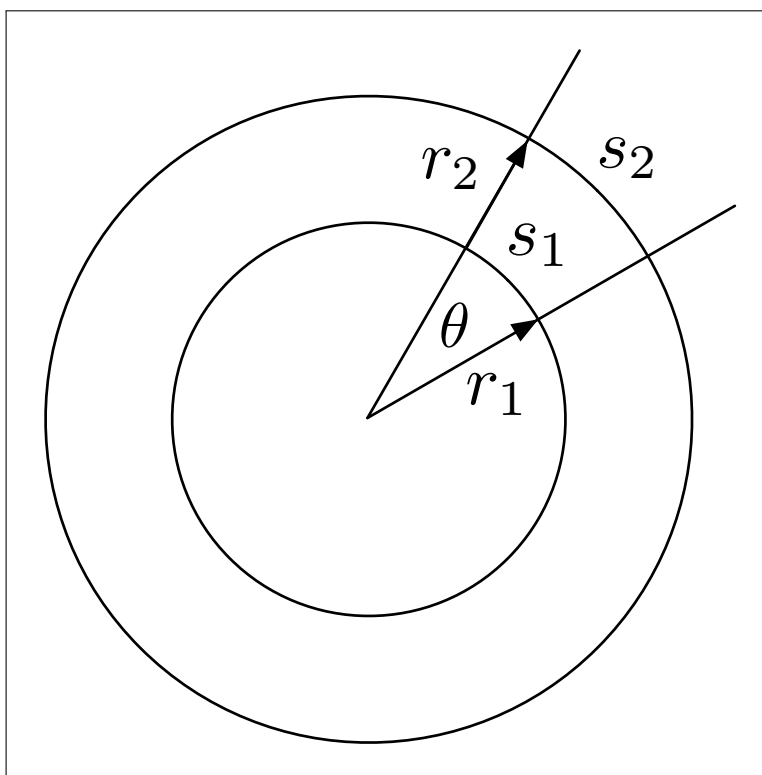

Figure 4: An angle θ with two concentric circles.

and in the values of the [Riemann zeta function](#) for positive even integers:⁴

$$\zeta(2n) = \sum_{k=1}^{\infty} \frac{1}{k^{2n}} = \frac{B_n}{2(2n)!} (2\pi)^{2n}. \quad n = 1, 2, 3, \dots$$

There are many more examples, and the conclusion is clear: there is something special about 2π .

To get to the bottom of this mystery, we must return to first principles by considering the nature of circles, and especially the nature of *angles*. Although it's likely that much of this material will be familiar, it pays to revisit it, for this is where the true understanding of τ begins.

2.1 Circles and angles

There is an intimate relationship between circles and angles, as shown in [Figure 4](#). Since the concentric circles in [Figure 4](#) have different radii, the lines in the figure cut off different lengths of arc (or *arclengths*), but the angle θ (theta) is the same in each case. In other words, the size of the angle does not depend on the radius of the circle used to define the arc. The principal task of angle measurement is to create a system that captures this radius-invariance.

Perhaps the most elementary angle system is *degrees*, which breaks a circle into [360 equal parts](#). One result of this system is the set of special angles (familiar to students of trigonometry) shown in [Figure 5](#).

⁴Here B_n is the n th [Bernoulli number](#).

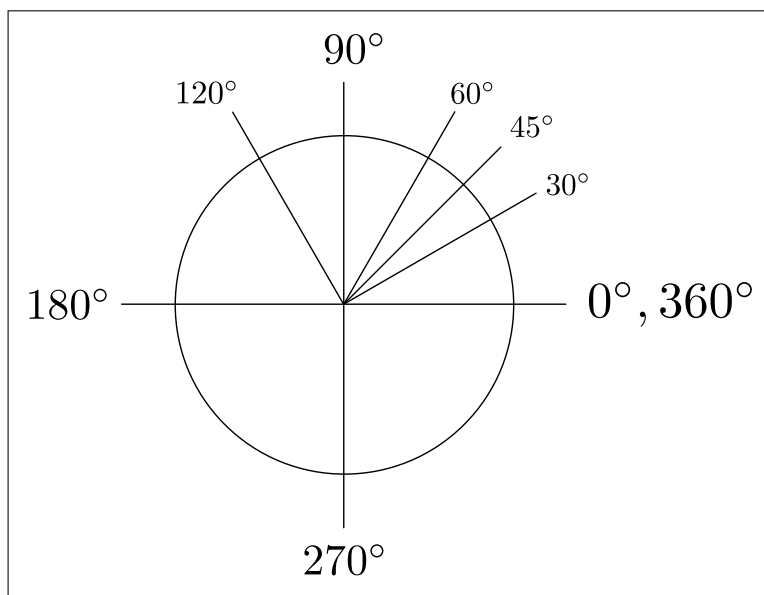

Figure 5: Some special angles, in degrees.

A more fundamental system of angle measure involves a direct comparison of the arclength s with the radius r . Although the lengths in Figure 4 differ, the arclength grows in proportion to the radius, so the *ratio* of the arclength to the radius is the same in each case:

$$s \propto r \Rightarrow \frac{s_1}{r_1} = \frac{s_2}{r_2}.$$

This suggests the following definition of *radian angle measure*:

$$\theta \equiv \frac{s}{r}.$$

This definition has the required property of radius-invariance, and since both s and r have units of length, radians are *dimensionless* by construction. The use of radian angle measure leads to succinct and elegant formulas throughout mathematics; for example, the usual formula for the derivative of $\sin \theta$ is true only when θ is expressed in radians:

$$\frac{d}{d\theta} \sin \theta = \cos \theta. \quad (\text{true only when } \theta \text{ is in radians})$$

Naturally, the special angles in Figure 5 can be expressed in radians, and when you took high-school trigonometry you probably memorized the special values shown in Figure 6. (I call this system of measure π -radians to emphasize that they are written in terms of π .)

Now, a moment's reflection shows that the so-called "special" angles are just particularly simple *rational fractions* of a full circle, as shown in Figure 7. This suggests revisiting the definition of radian angle measure, rewriting the arclength in terms of the fraction f of the full circumference:

$$\theta = \frac{s}{r} = \frac{fC}{r} = f \left(\frac{C}{r} \right) \equiv f\tau.$$

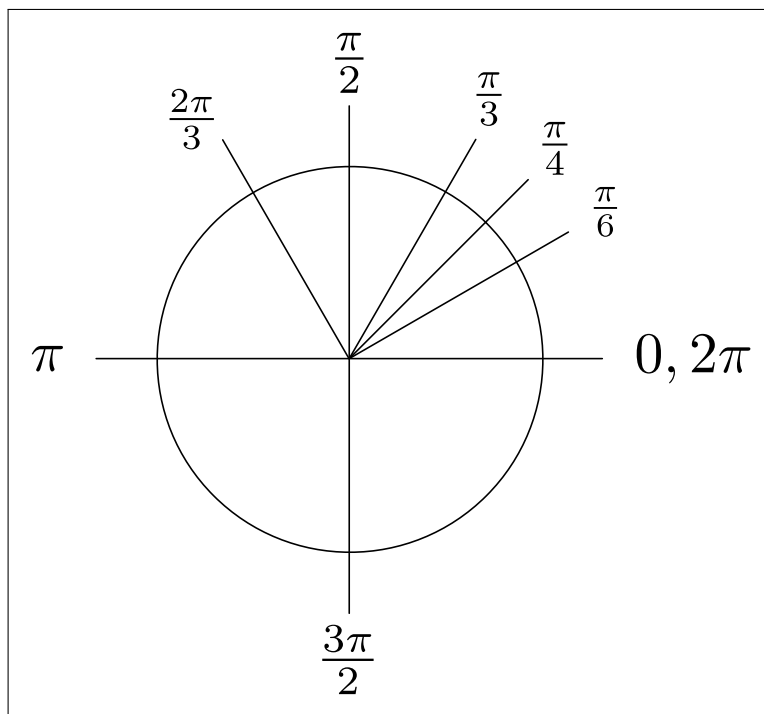

Figure 6: Some special angles, in π -radians.

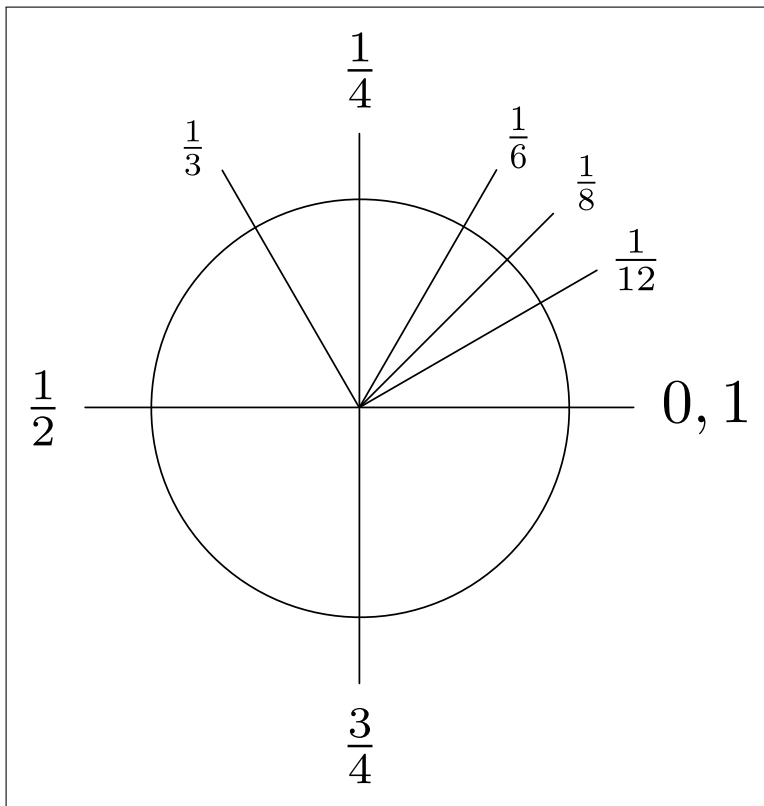

Figure 7: The “special” angles are fractions of a full circle.

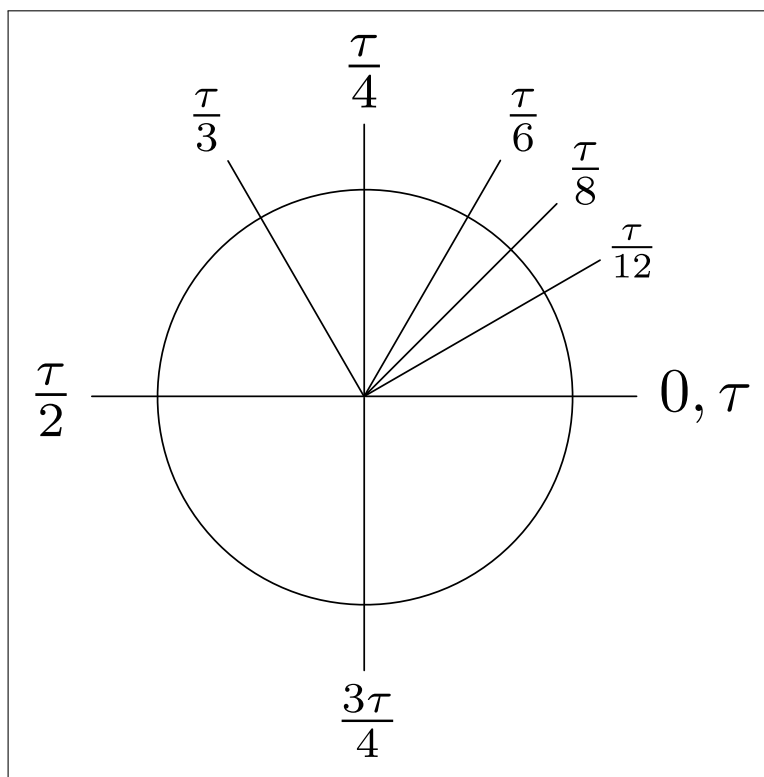

Figure 8: Some special angles, in radians.

Notice how naturally τ falls out of this analysis. If you are a believer in π , I fear that the resulting diagram of special angles—shown in Figure 8—will shake your faith to its very core.

Although there are many other arguments in τ 's favor, Figure 8 may be the most striking. Indeed, upon comparing Figure 8 with Figure 7, I consider it decisive. We also see from Figure 8 the genius of Bob Palais' identification of the circle constant as “one turn”: τ is the radian angle measure for one *turn* of a circle. Moreover, note that with τ there is *nothing to memorize*: a twelfth of a turn is $\tau/12$, an eighth of a turn is $\tau/8$, and so on. Using τ gives us the best of both worlds by combining conceptual clarity with all the concrete benefits of radians; the abstract meaning of, say, $\tau/12$ is obvious, but it is also just a number:

$$\text{a twelfth of a turn} = \frac{\tau}{12} \approx \frac{6.283185}{12} = 0.5235988.$$

Finally, by comparing Figure 6 with Figure 8, we see where those pesky factors of 2π come from: one turn of a circle is 1τ , but 2π . Numerically they are equal, but conceptually they are quite distinct.

2.1.1 The ramifications

The unnecessary factors of 2 arising from the use of π are annoying enough by themselves, but far more serious is their tendency to *cancel* when divided by any even number. The absurd results, such as a *half* π for a *quarter* circle, obscure the underlying relationship between angle measure and the circle constant. To those who maintain that it “doesn't matter” whether we use π or τ when teaching trigonometry, I simply ask you

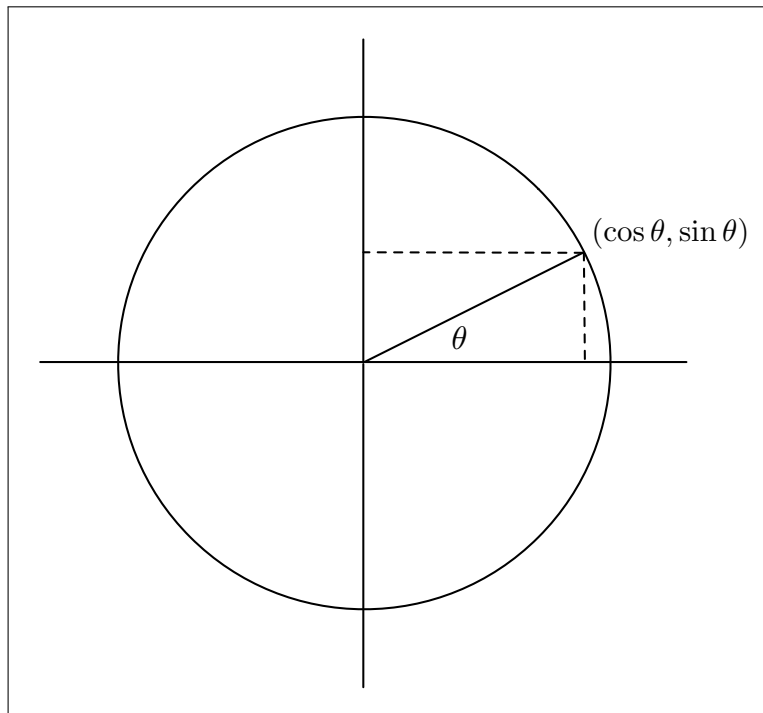

Figure 9: The circle functions are coordinates on the unit circle.

to view [Figure 6](#), [Figure 7](#), and [Figure 8](#) through the eyes of a child. You will see that, from the perspective of a beginner, *using π instead of τ is a pedagogical disaster*.

2.2 The circle functions

Although radian angle measure provides some of the most compelling arguments for the true circle constant, it’s worth comparing the virtues of π and τ in some other contexts as well. We begin by considering the important elementary functions $\sin \theta$ and $\cos \theta$. Known as the “circle functions” because they give the coordinates of a point on the *unit circle*⁵ ([Figure 9](#)), sine and cosine are the fundamental functions of trigonometry.

Let’s examine the graphs of the circle functions to better understand their behavior.⁶ You’ll notice from [Figure 10](#) and [Figure 11](#) that both functions are *periodic* with period T .⁷ As shown in [Figure 10](#), the sine function $\sin \theta$ starts at zero, reaches a maximum at a quarter period, passes through zero at a half period, reaches a minimum at three-quarters of a period, and returns to zero after one full period. Meanwhile, the cosine function $\cos \theta$ starts at a maximum, has a minimum at a half period, and passes through zero at one-quarter and three-quarters of a period ([Figure 11](#)). For reference, both figures show the value of θ (in radians) at each special point.

Of course, since sine and cosine both go through one full cycle during one turn of the circle, we have $T = \tau$; i.e., the circle functions have periods equal to the circle constant. As a result, the “special” values of

⁵A “unit” in this context is the number 1, and a unit circle is a circle whose diameter—no, wait, *radius*—is equal to one unit.

⁶These graphs were produced with the help of [Wolfram Alpha](#).

⁷I swear I’m not stacking the deck here; T really is the usual letter in this context.

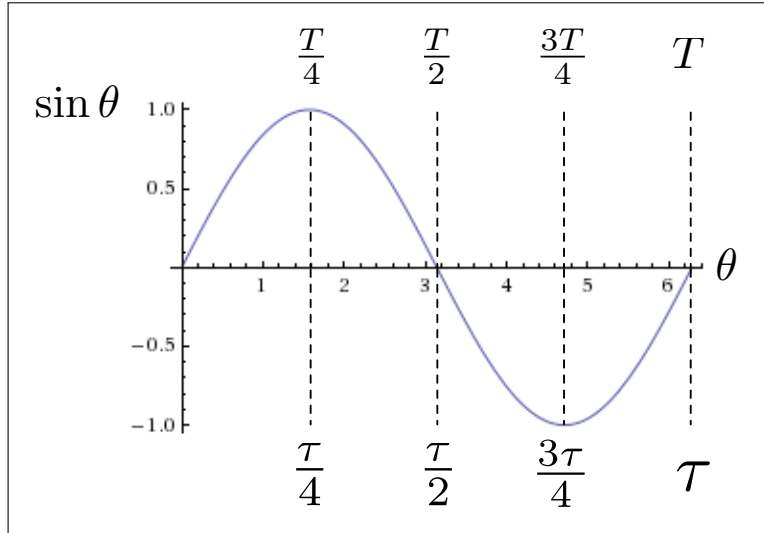

Figure 10: Important points for $\sin \theta$ in terms of the period T .

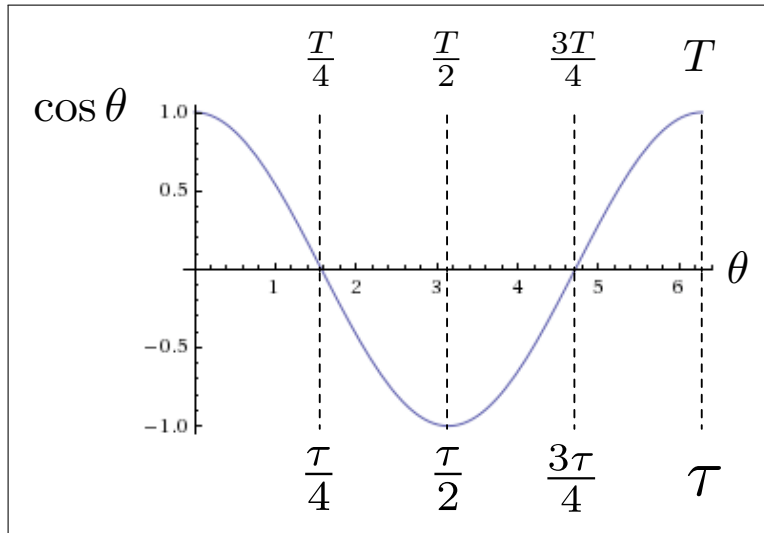

Figure 11: Important points for $\cos \theta$ in terms of the period T .

θ are utterly natural: a quarter-period is $\tau/4$, a half-period is $\tau/2$, etc. In fact, when making Figure 10, at one point I found myself wondering about the numerical value of θ for the zero of the sine function. Since the zero occurs after half a period, and since $\tau \approx 6.28$, a quick mental calculation led to the following result:

$$\theta_{\text{zero}} = \frac{\tau}{2} \approx 3.14.$$

That’s right: I was astonished to discover that *I had already forgotten that $\tau/2$ is sometimes called “ π ”*. Perhaps this even happened to you just now. Welcome to my world.

2.3 Euler’s identity

I would be remiss in this manifesto not to address *Euler’s identity*, sometimes called “the most beautiful equation in mathematics”. This identity involves *complex exponentiation*, which is deeply connected both to the circle functions and to the geometry of the circle itself.

Depending on the route chosen, the following equation can either be proved as a theorem or taken as a definition; either way, it is quite remarkable:

$$e^{i\theta} = \cos \theta + i \sin \theta.$$

Known as *Euler’s formula* (after [Leonhard Euler](#)), this equation relates an exponential with imaginary argument to the circle functions sine and cosine and to the imaginary unit i . Although justifying Euler’s formula is beyond the scope of this manifesto, its provenance is above suspicion, and its importance is beyond dispute.

Evaluating Euler’s formula at $\theta = \tau$ yields *Euler’s identity*:⁸

$$e^{i\tau} = 1.$$

In words, this equation makes the following fundamental observation:

The complex exponential of the circle constant is unity.

Geometrically, multiplying by $e^{i\theta}$ corresponds to rotating a complex number by an angle θ in the complex plane, which suggests a second interpretation of Euler’s identity:

A rotation by one turn is 1.

Since the number 1 is the [multiplicative identity](#), the geometric meaning of $e^{i\tau} = 1$ is that rotating a point in the complex plane by one turn simply returns it to its original position.

As in the case of radian angle measure, we see how natural the association is between τ and one turn of a circle. Indeed, the identification of τ with “one turn” makes Euler’s identity sound almost like a tautology.⁹

2.3.1 Not the most beautiful equation

Of course, the traditional form of Euler’s identity is written in terms of π instead of τ . To derive it, we start by evaluating Euler’s formula at $\theta = \pi$, which yields

$$e^{i\pi} = -1.$$

⁸Here I’m implicitly defining Euler’s identity to be *the complex exponential of the circle constant*, rather than defining it to be the complex exponential of any particular number. If we choose τ as the circle constant, we obtain the identity shown. As we’ll see momentarily, this is not the traditional form of the identity, which of course involves π , but the version with τ is the most *mathematically* meaningful statement of the identity, so I believe it deserves the name.

⁹Technically, all mathematical theorems are tautologies, but let’s not be so pedantic.

Rotation angle	Eulerian identity
0	$e^{i \cdot 0} = 1$
$\tau/4$	$e^{i\tau/4} = i$
$\tau/2$	$e^{i\tau/2} = -1$
$3\tau/4$	$e^{i \cdot (3\tau/4)} = -i$
τ	$e^{i\tau} = 1$

Table 1: Eulerian identities for half, quarter, and full rotations.

But that minus sign is so ugly that the formula is almost always rearranged immediately, giving the following “beautiful” equation:

$$e^{i\pi} + 1 = 0.$$

(What’s up with that minus sign? And why does “the most beautiful equation in mathematics” need rearranging? *Move along, move along, these aren’t the droids we’re looking for...*)

At this point, the expositor usually makes some grandiose statement about how Euler’s identity relates 0, 1, e , i , and π —sometimes called the “five most important numbers in mathematics”. Alert readers might then complain that, because it’s missing 0, Euler’s identity with τ relates only *four* of those five. We can address this objection by noting that, since $\sin \tau = 0$, we were already there:

$$e^{i\tau} = 1 + 0.$$

This formula, without rearrangement, actually *does* relate the five most important numbers in mathematics: 0, 1, e , i , and τ .

2.3.2 Eulerian identities

Since you can add 0 anywhere in any equation, the introduction of 0 into the formula $e^{i\tau} = 1 + 0$ is a somewhat tongue-in-cheek counterpoint to $e^{i\pi} - 1 = 0$, but the identity $e^{i\pi} = -1$ does have a more serious point to make. Let’s see what happens when we rewrite it in terms of τ :

$$e^{i\tau/2} = -1.$$

Geometrically, this says that a rotation by half a turn is the same as multiplying by -1 . And indeed this is the case: under a rotation of $\tau/2$ radians, the complex number $z = a + ib$ gets mapped to $-a - ib$, which is in fact just $-1 \cdot z$.

Written in terms of τ , we see that the “original” form of Euler’s identity has a transparent geometric meaning that it lacks when written in terms of π .¹⁰ The quarter-angle identities have similar geometric interpretations: $e^{i\tau/4} = i$ says that a quarter turn in the complex plane is the same as multiplication by i , while $e^{i \cdot (3\tau/4)} = -i$ says that three-quarters of a turn is the same as multiplication by $-i$. A summary of these results, which we might reasonably call *Eulerian identities*, appears in Table 1.

We can take this analysis a step further by noting that, for any angle θ , $e^{i\theta}$ can be interpreted as a point lying on the unit circle in the complex plane. Since the complex plane identifies the horizontal axis with the real part of the number and the vertical axis with the imaginary part, Euler’s formula tells us that $e^{i\theta}$ corresponds to the coordinates $(\cos \theta, \sin \theta)$. Plugging in the values of the “special” angles from Figure 8

¹⁰Of course, $e^{i\pi} = -1$ can be interpreted as a rotation by π radians, but the near-universal rearrangement to form $e^{i\pi} + 1 = 0$ shows how using π distracts from the identity’s natural geometric meaning.

Polar form	Rectangular form	Coordinates
$e^{i\theta}$	$\cos \theta + i \sin \theta$	$(\cos \theta, \sin \theta)$
$e^{i \cdot 0}$	1	(1, 0)
$e^{i\tau/12}$	$\frac{\sqrt{3}}{2} + \frac{1}{2}i$	$(\frac{\sqrt{3}}{2}, \frac{1}{2})$
$e^{i\tau/8}$	$\frac{1}{\sqrt{2}} + \frac{1}{\sqrt{2}}i$	$(\frac{1}{\sqrt{2}}, \frac{1}{\sqrt{2}})$
$e^{i\tau/6}$	$\frac{1}{2} + \frac{\sqrt{3}}{2}i$	$(\frac{1}{2}, \frac{\sqrt{3}}{2})$
$e^{i\tau/4}$	i	(0, 1)
$e^{i\tau/3}$	$-\frac{1}{2} + \frac{\sqrt{3}}{2}i$	$(-\frac{1}{2}, \frac{\sqrt{3}}{2})$
$e^{i\tau/2}$	-1	(-1, 0)
$e^{i \cdot (3\tau/4)}$	-i	(0, -1)
$e^{i\tau}$	1	(1, 0)

Table 2: Complex exponentials of the special angles from Figure 8.

then gives the points shown in Table 2, and plotting these points in the complex plane yields Figure 12. A comparison of Figure 12 with Figure 8 quickly dispels any doubts about which choice of circle constant better reveals the relationship between Euler’s formula and the geometry of the circle.

3 Circular area: the *coup de grâce*

If you arrived here as a π believer, you must by now be questioning your faith. τ is so natural, its meaning so transparent—is there no example where π shines through in all its radiant glory? A memory stirs—yes, there is such a formula—it is the formula for circular area! Behold:

$$A = \pi r^2.$$

We see here π , unadorned, in one of the most important equations in mathematics—a formula first proved by Archimedes himself. Order is restored! And yet, the name of this section sounds ominous. . . If this equation is π ’s crowning glory, how can it also be the *coup de grâce*?

3.1 Quadratic forms

Let us examine this paragon of π , $A = \pi r^2$. We notice that it involves the diameter—no, wait, the *radius*—raised to the second power. This makes it a simple *quadratic form*. Such forms arise in many contexts; as a physicist, my favorite examples come from the elementary physics curriculum. We will now consider several in turn.

3.1.1 Falling in a uniform gravitational field

Galileo Galilei found that the velocity of an object falling in a uniform gravitational field is proportional to the time fallen:

$$v \propto t.$$

The constant of proportionality is the gravitational acceleration g :

$$v = gt.$$

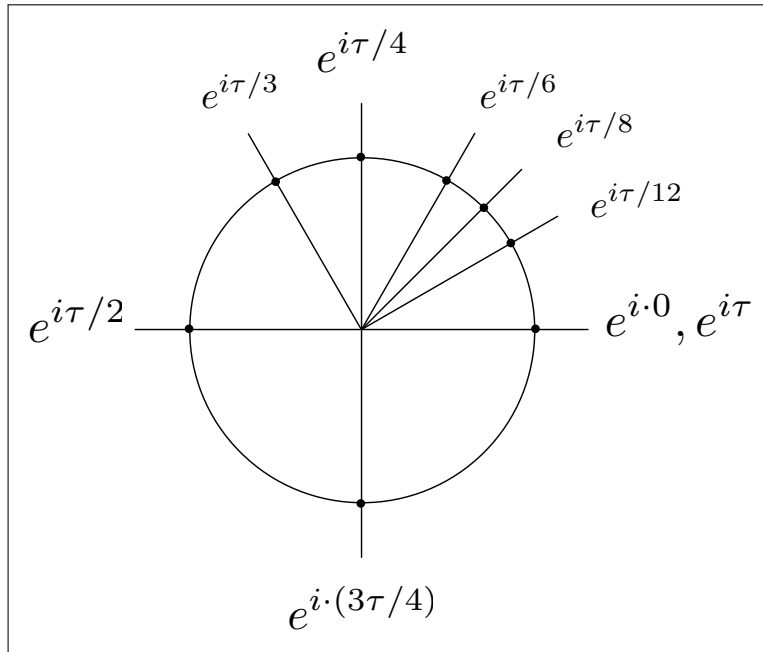

Figure 12: Complex exponentials of some special angles, plotted in the complex plane.

Since velocity is the derivative of position, we can calculate the distance fallen by integration:

$$y = \int v dt = \int_0^t gt dt = \frac{1}{2}gt^2.$$

3.1.2 Potential energy in a linear spring

[Robert Hooke](#) found that the external force required to stretch a spring is proportional to the distance stretched:

$$F \propto x.$$

The constant of proportionality is the spring constant k :¹¹

$$F = kx.$$

The potential energy in the spring is then equal to the work done by the external force:

$$U = \int F dx = \int_0^x kx dx = \frac{1}{2}kx^2.$$

3.1.3 Energy of motion

[Isaac Newton](#) found that the force on an object is proportional to its acceleration:

$$F \propto a.$$

¹¹You may have seen this written as $F = -kx$. In this case, F refers to the force exerted by the *spring*. By Newton's third law, the external force discussed above is the *negative* of the spring force.

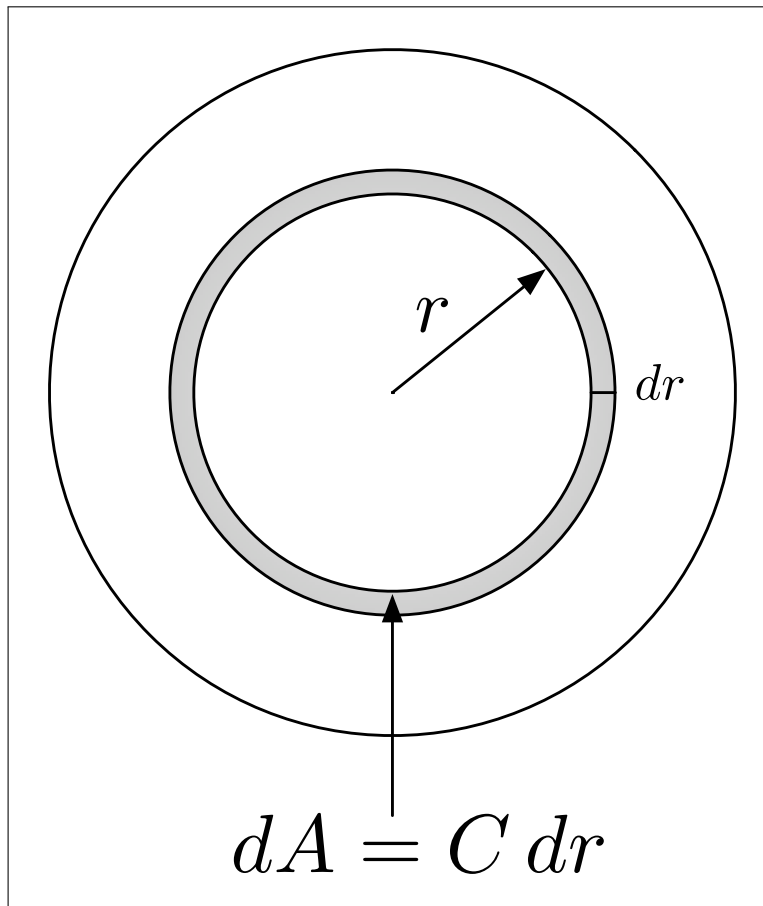

Figure 13: Breaking down a circle into rings.

The constant of proportionality is the mass m :

$$F = ma.$$

The energy of motion, or *kinetic energy*, is equal to the total work done in accelerating the mass to velocity v :

$$K = \int F dx = \int ma dx = \int m \frac{dv}{dt} dx = \int m \frac{dx}{dt} dv = \int_0^v mv dv = \frac{1}{2}mv^2.$$

3.2 A sense of foreboding

Having seen several examples of simple quadratic forms in physics, you may by now have a sense of foreboding as we return to the geometry of the circle. This feeling is justified.

As seen in Figure 13,¹² the area of a circle can be calculated by breaking it down into circular rings of

¹²This is a physicist's diagram. A mathematician would probably use Δr , limits, and [little-o notation](#), an approach that is more rigorous but less intuitive.

Quantity	Symbol	Expression
Distance fallen	y	$\frac{1}{2}gt^2$
Spring energy	U	$\frac{1}{2}kx^2$
Kinetic energy	K	$\frac{1}{2}mv^2$
Circular area	A	$\frac{1}{2}\tau r^2$

Table 3: Some common quadratic forms.

length C and width dr , where the area of each ring is $C dr$:

$$dA = C dr.$$

Now, the circumference of a circle is proportional to its radius:

$$C \propto r.$$

The constant of proportionality is τ :

$$C = \tau r.$$

The area of the circle is then the integral over all rings:

$$A = \int dA = \int_0^r C dr = \int_0^r \tau r dr = \frac{1}{2}\tau r^2.$$

If you were still a π partisan at the beginning of this section, your head has now exploded. For we see that even in this case, where π supposedly shines, in fact there is a missing factor of 2. Indeed, the original proof by Archimedes shows not that the area of a circle is πr^2 , but that it is equal to the area of a right triangle with base C and height r . Applying the formula for triangular area then gives

$$A = \frac{1}{2}bh = \frac{1}{2}Cr = \frac{1}{2}\tau r^2.$$

There is simply no avoiding that factor of a half (Table 3).

3.2.1 Quod erat demonstrandum

We set out in this manifesto to show that τ is the true circle constant. Since the formula for circular area was just about the last, best argument that π had going for it, I'm going to go out on a limb here and say: **Q.E.D.**

4 Why tau?

The true test of any notation is usage; having seen τ used throughout this manifesto, you may already be convinced that it serves its role well. But for a constant as fundamental as τ it would be nice to have some deeper reasons for our choice. Why not α , for example, or ω ? What's so great about τ ?

4.1 Four arguments

Allow me to offer the following arguments for τ , in order of increasing strength:

1. τ already exists.

The letter τ already exists in current typesetting and word-processing systems, so there is no need to wait for a new symbol to be added before using it.

2. τ is available.

Although τ is used for certain *specific* variables—e.g., *shear stress* in mechanical engineering, *torque* in rotational mechanics, and *proper time* in special and general relativity—there is no *universal* conflicting usage. With a global namespace and only so many letters to go around, minor conflicts are inevitable, but that’s OK; physicists, for example, manage to use e both for the [natural number](#) and for the charge on an electron without causing apparent harm. (It’s worth noting in this context that even π has multiple uses, such as the [prime-counting function](#) and [osmotic pressure](#).) Furthermore, many quantities already have alternate symbols, such as N for torque in place of τ .¹³ In these cases, we can simply standardize on the non-conflicting alternative.

3. τ resembles π .

τ is typographically similar to π , thereby evoking the same notion of a circle constant, while still looking different enough to avoid confusion. At first glance, it appears that the number of “legs” isn’t quite right, since it looks like π might be 2τ instead of the other way ’round. On the other hand, the horizontal line in each letter suggests that we interpret the legs as *denominators*, so that π has *two* legs in its denominator, while τ has only one. Seen this way, the relationship $\tau = 2\pi$ is perfectly natural.¹⁴

4. τ is one turn.

We have seen that, geometrically speaking, τ represents one *turn* of a circle, and you may have noticed that “ τ ” and “turn” both start with a “ t ” sound. Perhaps this is only a coincidence? Alas, there is no escape, for the root of the English word “turn” is the Greek word for “lathe”: *tomos*—or, as the Greeks would put it,

$\tau\acute{o}\rho\nu\omicron\varsigma$.

The first two arguments are weak by themselves, but they are important prerequisites. The third argument is strong: after centuries of use, the association of π with the circle constant is unavoidable, and τ feeds on this association rather than fighting it. The final argument is the clincher—looking at the first letter of that Greek lathe, I’m going to have to whip out my Latin again and say: *quod erat demonstrandum*.

4.2 Frequently Asked Questions

Over the years, I have heard many arguments against the wrongness of π and against the correctness of τ ,¹⁵ so before concluding our discussion allow me to address some of the most frequently asked questions.

- **Are you serious?**

Of course. I mean, I’m having fun with this, and the tone is occasionally lighthearted, but there is a serious purpose. Setting the circle constant equal to the circumference over the diameter is an awkward and confusing convention. Although I would love to see mathematicians change their ways, I’m not particularly worried about them; they can take care of themselves. It is the neophytes I am most worried about, for they take the brunt of the damage: as noted in [Section 2.1](#), π is a pedagogical disaster. Try explaining to a twelve-year-old (or to a thirty-year-old) why the angle measure for an eighth of

¹³See, for example, *Introduction to Electrodynamics* by David Griffiths, p. 162.

¹⁴Thanks to reader *Tau Manifesto* Jim Porter for pointing out this alternate interpretation.

¹⁵Among other things, the article “ π Is Wrong!” pops up on [Hacker News](#) every once in a while, and I’ve been known to frequent the [comments section](#).

a circle—one slice of pizza—is $\pi/8$. Wait, I meant $\pi/4$. See what I mean? It’s madness—sheer, unadulterated madness.

- **Why not use the symbol from “ π Is Wrong!”?**

There are two main issues with the symbol from “ π Is Wrong!” (Figure 1).¹⁶ The first is that it is highly non-standard. Although this means that it doesn’t conflict with any current usage, that’s a *Pyrrhic victory*, since it also means that the symbol doesn’t exist in any current typesetting or word-processing systems.¹⁷ This presents a high barrier to adoption. Second, the name “one turn”, though descriptive, doesn’t work well in some common contexts. For example, saying that a quarter circle has radian angle measure “one quarter turn” sounds great, but “turn over four radians” sounds awkward, and “the area of a circle is one-half turn r squared” sounds downright odd. Letting $\tau = \textit{turn}$ leads to much more natural phrasing, such as “tau over four radians” and “the area of a circle is one-half tau r squared.”

- **How can we switch from π to τ ?**

The next time you write something that uses the circle constant, simply say “For convenience, we set $\tau = 2\pi$ ”, and then proceed as usual. (Of course, this might just prompt the question, “Why would you want to do that?”, and I admit it would be nice to have a place to point them to. If only someone would write, say, a *manifesto* on the subject. . .) The way to get people to start using τ is to start using it yourself.

- **Isn’t it too late to switch? Wouldn’t all the textbooks and math papers need to be rewritten?**

No on both counts. It is true that some conventions, though unfortunate, are effectively irreversible. For example, Benjamin Franklin’s choice for the signs of electric charges leads to electric current being positive, even though the charge carriers themselves are negative—thereby cursing electrical engineers with confusing minus signs ever since.¹⁸ To change this convention *would* require rewriting all the textbooks (and burning the old ones) since it is impossible to tell at a glance which convention is being used. In contrast, while *redefining* π is effectively impossible, we can switch from π to τ “at runtime” (as programmers might say)—it’s purely a matter of mechanical substitution, completely robust and indeed fully reversible: the conversion

$$\pi \leftrightarrow \frac{1}{2}\tau$$

allows us to change back and forth between the two on the fly. The switch from π to τ can therefore happen incrementally; unlike a redefinition, it need not happen all at once.

- **Won’t using τ confuse people, especially students?**

If you are smart enough to understand radian angle measure, you are smart enough to understand τ —and why τ is actually *less* confusing than π . Also, there is nothing intrinsically confusing about saying “Let $\tau = 2\pi$ ”; understood narrowly, it’s just a simple substitution. Finally, we can embrace the situation as a teaching opportunity: the idea that π might be wrong is *interesting*, and students can engage with the material by converting the equations in their textbooks from π to τ to see for themselves which choice is better.

¹⁶These problems aren’t necessarily fatal, and the *Tau Manifesto* reserves the right to support Palais’ symbol if these issues ever get fixed.

¹⁷There’s a hack for defining Palais’ symbol in the L^AT_EX typesetting system (which is how Palais himself did it), but even this doesn’t always work: the [online version](#) of the *Tau Manifesto* was prepared with the help of T_EX-based math processors, and it still chokes on the symbol from Figure 1. (This is why I keep referring to it as “the symbol from Figure 1” instead of just typesetting the darn thing.)

¹⁸The sign of the charge carriers couldn’t be determined with the technology of Franklin’s time, so this isn’t his fault. It’s just bad luck.

- **Who cares whether we use π or τ ? It doesn't really matter.**

Of course it matters. *The circle constant is important.* People care enough about it to write entire books on the subject, to celebrate it on a particular day each year, and to memorize tens of thousands of its digits. I care enough to write a whole manifesto, and you care enough to read it. It's precisely because it *does* matter that it's hard to admit that the present convention is wrong. (I mean, how do you break it to [Lu Chao](#), the current world-record holder, that he just recited 67,890 digits of one half of the true circle constant?)¹⁹ Since the circle constant is important, it's important to get it right, and we have seen in this manifesto that the right number is τ . Although π is of great *historical* importance, the *mathematical* significance of π is that it is one-half τ .

- **Why does this subject interest you?**

First, as a truth-seeker I care about correctness of explanation. Second, as a teacher I care about clarity of exposition. Third, as a hacker I love a nice hack. Fourth, as a student of history and of human nature I find it fascinating that the absurdity of π was lying in plain sight for centuries before anyone seemed to notice. Moreover, many of the people who missed the true circle constant are among the most rational and intelligent people ever to live. What else might be staring us in the face, just waiting for us to discover it?

- **Are you, like, a crazy person?**

That's really none of your business, but no. Apart from my [unusual shoes](#), I am to all external appearances normal in every way. You would never guess that, far from being an ordinary citizen, I am in fact a notorious mathematical propagandist.

- **But what about puns?**

We come now to the final objection. I know, I know, " π in the sky" is so very clever. And yet, τ itself is pregnant with possibilities. τ ism tells us: it is not τ that is a piece of π , but π that is a piece of τ —one-half τ , to be exact. The identity $e^{i\tau} = 1$ says: "*Be 1 with the τ .*" And though the observation that "*A rotation by one turn is 1*" may sound like a τ -ology, it is the true nature of the τ . As we contemplate this nature to seek the [way](#) of the τ , we must remember that τ ism is based on reason, not on faith: τ ists are never π ous.

5 Embrace the tau

We have seen in the *Tau Manifesto* that the natural choice for the circle constant is the ratio of a circle's circumference not to its diameter, but to its radius. This number needs a name, and I hope you will join me in calling it τ :

$$\text{circle constant} = \tau \equiv \frac{C}{r} = 6.283185307179586 \dots$$

The usage is natural, the motivation is clear, and the implications are profound. Plus, it comes with a really cool diagram ([Figure 14](#)).

We see in [Figure 14](#) a movement through *yang* ("light, white, moving up") to $\tau/2$ and a return through *yin* ("dark, black, moving down") back to τ .²⁰ Using π instead of τ is like having *yang* without *yin*.

¹⁹On the other hand, this could be an opportunity: the field for τ recitation records is wide open.

²⁰The interpretations of *yin* and *yang* quoted here are from *Zen Yoga: A Path to Enlightenment through Breathing, Movement and Meditation* by Aaron Hoopes.

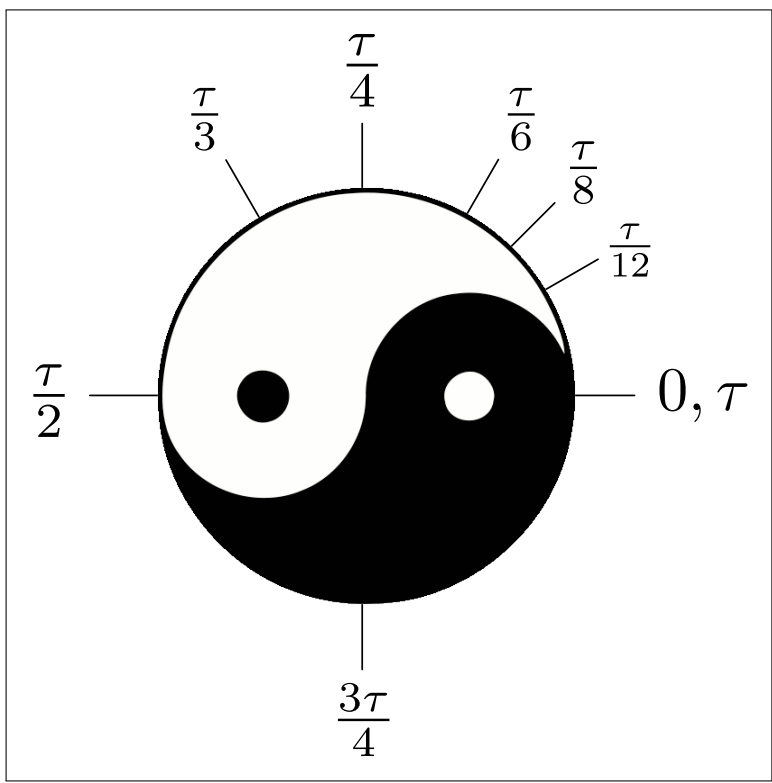

Figure 14: Followers of τ ism seek the way of the τ .

5.1 Tau Day

The *Tau Manifesto* first launched on Tau Day: June 28 (6/28), 2010. Tau Day is a time to celebrate and rejoice in all things mathematical and true.²¹ If you would like to receive updates about τ , including notifications about possible future Tau Day events, please join the *Tau Manifesto* mailing list below. And if you think that the circular baked goods on Pi Day are tasty, just wait—Tau Day has twice as much pi(e)!

Thank you for reading the *Tau Manifesto*. I hope you enjoyed reading it as much as I enjoyed writing it. And I hope even more that you have come to embrace the true circle constant: not π , but τ . Happy Tau Day!

The signup form is available online at http://tauday.com/#sec:tau_day.

5.1.1 Acknowledgments

I'd first like to thank [Bob Palais](#) for writing “ π Is Wrong!”. I don't remember how deep my suspicions about π ran before I encountered that article, but “ π Is Wrong!” definitely opened my eyes, and every section of the *Tau Manifesto* owes it a debt of gratitude. I'd also like to thank Bob for his helpful comments on this manifesto, and especially for being such a good sport about it.

I've been thinking about the *Tau Manifesto* for a while now, and many of the ideas presented here were developed through conversations with my friend Sumit Daftuar. Sumit served as a sounding board and occasional Devil's advocate, and his insight as a teacher and as a mathematician influenced my thinking in many ways.

I also received helpful feedback from several readers. The pleasing interpretation of the yin-yang symbol used in the *Tau Manifesto* is due to a suggestion by [Peter Harremoës](#), who has the rare distinction of having independently proposed using τ for the circle constant. I also got several good suggestions from [Christopher Olah](#), particularly regarding the geometric interpretation of Euler's identity, and [Section 2.3.2](#) on Eulerian identities was inspired by an excellent suggestion from Timothy “Patashu” Stiles. Finally, I'd like to thank [Wyatt Greene](#) for his extraordinarily helpful feedback on a pre-launch draft of the manifesto; among other things, if you ever need someone to tell you that “pretty much all of [now deleted] section 5 is total crap”, Wyatt is your man.

5.1.2 About the author

Tau Manifesto author [Michael Hartl](#) is an educator and entrepreneur. He is the founder of the [Ruby on Rails Tutorial](#) project, which teaches web development using [Ruby on Rails](#). Previously, he taught theoretical and computational physics at [Caltech](#), where he received the Lifetime Achievement Award for Excellence in Teaching. He is a graduate of [Harvard College](#) and has a [Ph.D. in Physics](#) from the [California Institute of Technology](#).

Michael is ashamed to admit that he knows 50 digits of π —approximately 48 more than Matt Groening. To make up for this, he is currently memorizing 52 digits of τ .²²

5.1.3 Copyright and license

The Tau Manifesto. Copyright © 2010 by Michael Hartl. Please feel free to share the *Tau Manifesto*, which is available under the [Creative Commons Attribution-NonCommercial-NoDerivs 3.0 Unported License](#). This

²¹Since 6 and 28 are the first two *perfect numbers*, 6/28 is actually a *perfect day*.

²²This is so that I know more digits of τ than I do of π , and τ doesn't round off properly if you truncate after 51 digits. But you probably figured that out already. By the way, when I say “digits”, I really mean “decimal places”. But you probably figured that out, too.

means that you can't alter it or sell it, but you do have permission to distribute copies of the [Tau Manifesto PDF](#), print it out, use it in classrooms, and so on. Go forth and spread the good news about τ !