

HEAVY MOVABLE STRUCTURES, INC.

EIGHTH BIENNIAL SYMPOSIUM

NOVEMBER 8 – 10, 2000

Grosvenor Resort
Walt Disney World Village
Lake Buena Visa, Florida

“Suez Canal Bridge at El Ferdan”

by Michael J. Abrahams, P.E.
Parsons Brinckerhoff Quade & Douglas,
Inc.

SUEZ CANAL SWING BRIDGE

by

Michael J. Abrahams⁽¹⁾

The first Egyptian National Railways (ENR) movable bridge across the Suez dates to the First World War. It was a 5 span truss with a total length of 146m located 33 km south of Port Said. It had two swing spans, 48m and 28m long, which provided a 42m opening. It was destroyed in 1921 for unknown reasons. The second ENR movable bridge was completed in 1942, during the Second World War, 64 km south of Port Said. It was a 151m long truss bridge with two movable spans and a clear opening of 67m. In 1947 it was partially destroyed by a ship collision and was rebuilt in 1949.

The third ENR bridge was constructed at El-Ferdan 68.44 km south of Port Said, 4.44km to the south of the third bridge, and was opened to traffic in 1954. It had a length of 210m with 2 swing spans and center-to-center pivot pier distance of 112.5m. It provided a 96m opening. The second bridge was destroyed in 1956 due to war, leaving only the third bridge. In 1962 the fourth bridge at El-Ferdan was started about 100m to the north of the third bridge. This bridge was completed in 1963 and was the largest swing bridge in the world with 167.5m center-to-center of pivot pier dimension. The bridge had an overall length of 318m and provided a 148m opening. This bridge was destroyed in the 1967 Six Day War.

The fifth ENR bridge, which is the one that is now under construction, is on the same alignment as the fourth bridge.

To replace the fourth bridge, in 1995 the ENR requested design-build proposals from international consortiums, and in July 1996 a \$US70 million contract to design and build the bridge was awarded to Consortium El-Ferdan, led by Krupp of Germany in joint venture with Besin of Belgium and Orescom of Egypt. Halcrow Consulting Engineers & Architects, Ltd. is serving technical adviser to ENR and is providing quality audits of the design and construction.

(1) Principal Professional Associate, Parsons Brinckerhoff Quade & Douglas, Inc., One Penn Plaza, New York, N.Y., 10119, 212-465-5185, E-mail address abrahams@pbworld.com.

The price has now been increased to approximately \$80 million due to changes including increasing the main span from 320 to 340 meters to accommodate a wider canal than originally envisioned, Figure 1. The cost of construction includes a considerable amount of infrastructure to support the bridge including extensive worker housing. Site work began April 1998 after the site was cleared, munitions removed and the canal widened by the Suez Canal Authority.

The overall configuration is shown in Figure 1, the center to center pivot distance is 340m and the overall length is 640m. Each swing span is 320m long. The maximum height is 60m and the bottom chord is 6.5m above water in the closed position. In the open position, a 320m wide horizontal clearance is provided. The trusses in the open position are protected by reinforced concrete jetties along the sides of the canal supported on coated steel piles.

The two swing spans are welded steel trusses with an orthotropic steel deck. The deck provides for two 3m wide vehicular lanes and one railway track down the center of the swing span, Figure 2. The track uses timber ties that rest on the steel deck with steel stringers below the steel deck to support the ties. The truss chords are 1.2m wide, the center-to-center truss distance is 11.4m and the overall width is 12.6m, except at the pivot pier where the truss flares out to 15.8m centers, Figure 3. The floorbeams are 1m deep and while the lower chords are 2.0m deep x 1.2m wide (3.5m deep at the pivot) the upper chords are 1.0m deep and 1.2m wide.

The structure uses Grade ST52 steel. Of the 10,500 tonnes of structural steel work required, including 1,200 tonnes of machinery, approximately 4,000 tonnes were fabricated in Germany by Krupp with the remainder fabricated in Egypt.

The vertical load of each swing span on the pivot pier while swinging is 6,800 tonnes and the maximum dead and live load at each swing span is 9,100 tonnes. Each pivot pier is constructed using 38-1.5m \varnothing drilled shafts founded at a level of -29m. The drilled shafts were installed using bentonite to keep the holes open. Seven 1.5m drilled shafts founded at -18.5m are used at each abutment. Each pier cap is 4.35m thick, 23m diameter and contains 2,400m³ of concrete. Concrete exposed to canal water, which is saline, contains 8% silica fume with 75mm (3") cover used in these areas, with 50mm (2") elsewhere. In order to control heat build up and shrinkage, each cap was poured in 11 blocks, with the maximum pour being 358m³ and 1.2m thick. Thermocouples were used to monitor internal concrete temperatures with a combination of blankets and water used to control the concrete temperatures.

The bridge has a rim bearing swing spans. The trusses are supported on a steel grillage that is in turn supported by the drum girder at 8 points by means of pot bearings. The pot bearings appear to include provisions for expansion. The diameter of the track is 17m on 112 conical rollers, Figure 4. The center

pivot is 3.2m high with a 1.3m diameter. The entire assembly was shop assembled using a template prior to shipping to the site.

There are two electric slewing drives used to rotate the swing span. The overall opening or closing time is 30 minutes although only 12 minutes are required to swing the spans. Each drive uses a three phase squirrel-cage motor rated at 55Kw at 735 rpm. The motor drives a three stage planetary gear through a right angle drive, Figure 5. The 12 minutes swing time includes a 10 second acceleration and 10 second deceleration to a creep rate of 10% manual speed. In the creep mode, it takes 60 seconds to bring the bridge to fully stopped. The motors are controlled by frequency converters that operationally control speed and braking. Two hydraulic disc brakes function as an emergency and parking brake, Figure 6. The bridge can be turned using an auxiliary drives in 63 minutes or by hand in 1762 minutes. Automatic rail joints are provided at the center and end joints.

Two independent diesel generators power each swing span or an external power supply can be used. A control house is provided in each swing span. Two PLC's are used in each swing span, one controls the bridge machinery while the second controls the railroad signals.

Off-set lock bars are used at the top and bottom chords at midspan, Figures 7, 8, 9. The bars are 50 x 90cm and are driven by a 45Kw unit. Similar lock bars are used at the far ends of the swing spans, Figure 10. These are 55 x 55cm bars used to prevent vertical and horizontal movement of the swing spans in the open position. The end lock bars engage lock boxes mounted at the end of each jetty in the open position to hold the spans.

Both a seismic analysis and aerodynamic stability analyses were conducted. The seismic analysis was a multimode spectrum analysis for $g = 0.125$. The case of dead and 50% live load was used for the lowest 10 eigen values. The following combinations were used:

$$N_1 = 0.67 N_x + N_y$$

$$N_2 = 0.67 N_y + N_z$$

$$N_3 = 0.67 N_y + N_x/\sqrt{2} + N_z/\sqrt{2}$$

In the turning and open position the bridge was checked without live load.

The wind analysis found the critical wind to be 172 m/s and not a problem. However several diagonals and posts and one upper chord member were changed from I to box sections to prevent fatigue from vortex-induced or galloping oscillations.

A prime and 3 top coats of paint are applied in the shop with a fifth top coat field applied. This paint system has a 30 year design life. The longer life span perhaps reflecting some optimism in the future of the bridge. Certainly this will be an impressive achievement, surpassing any movable bridge in terms of its opening and span. One can only hope that its lifespan will exceed that of its predecessors.

REFERENCE:

1. M.J. Abrahams, Suez Canal Swing Bridge, 7th Biennial Symposium, Orlando Florida, 1998.
2. The History of El-Ferdan Railway Bridges across Suez Canal, Journal of the Egyptian Syndicate of Engineers, September, 1999.
3. Eckerhard Adrian, Horst Kruger, and Jurgen Hess Mechanical Engineering, Drive and Control Technology of the El-Ferdan Railway Swing Bridge, Bridge Engineering Conference 2000, Past Achievements, Current Practices, Future Technologies, March 2000, Sharm El-Sheikh, Sinai, Egypt.
4. Berthold Schlecht, Dieter Wunsch, Andre Christianhemmers, Ralf Hoffmann and Guido Lisenfeld, Multibody-System-Simulation of the El-Ferdan Swing Steel Railway Bridge, Ibid.
5. Nawal Taha and Roger Buckby, The El-Ferdan Bridge Over the Suez Canal Rail Link to the Sinai, Ibid
6. C.K. Tomlinson, U. Wayer, L. Maertes and Bernd Biner, El-Ferdan Bridge – Design , Ibid
7. David H. Mizon, Dennis Mohammed and Bernie Binder, El-Ferdan Bridge – Construction, Ibid

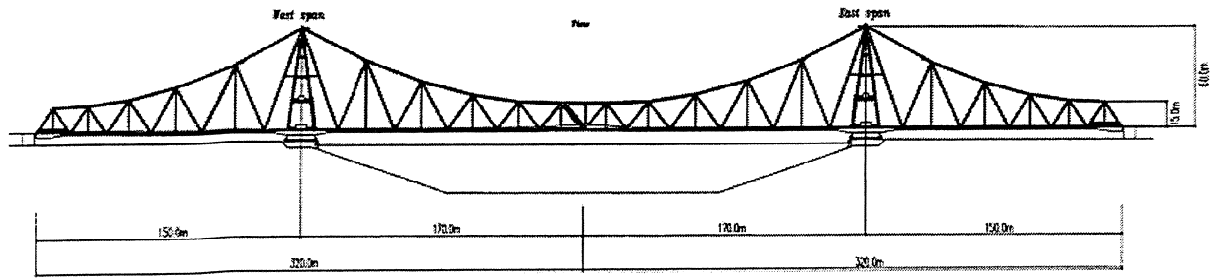

Figure 1: General View of El-Ferdan Bridge (Ref. 6)

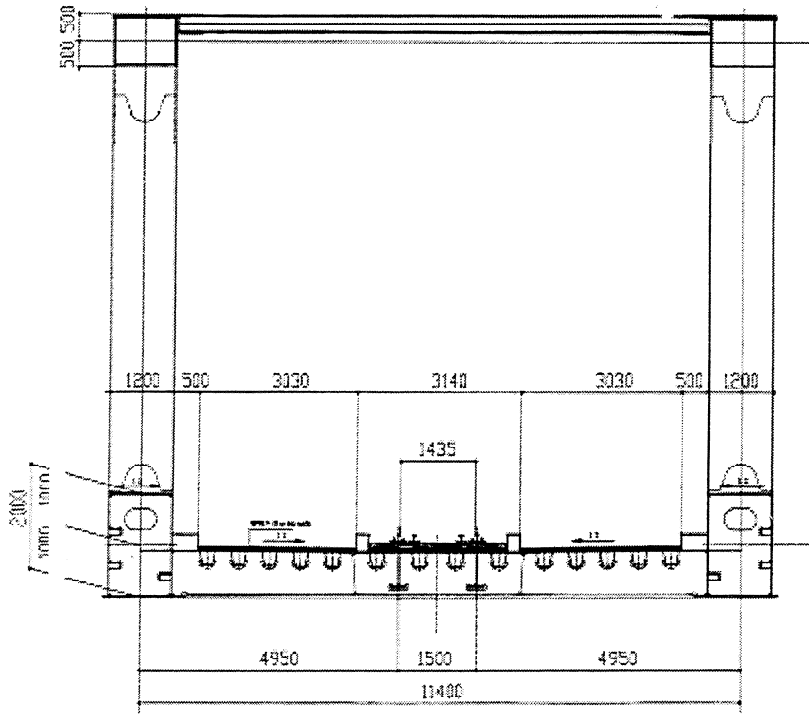

Figure 2: Cross Section Road Deck (Ref. 6)

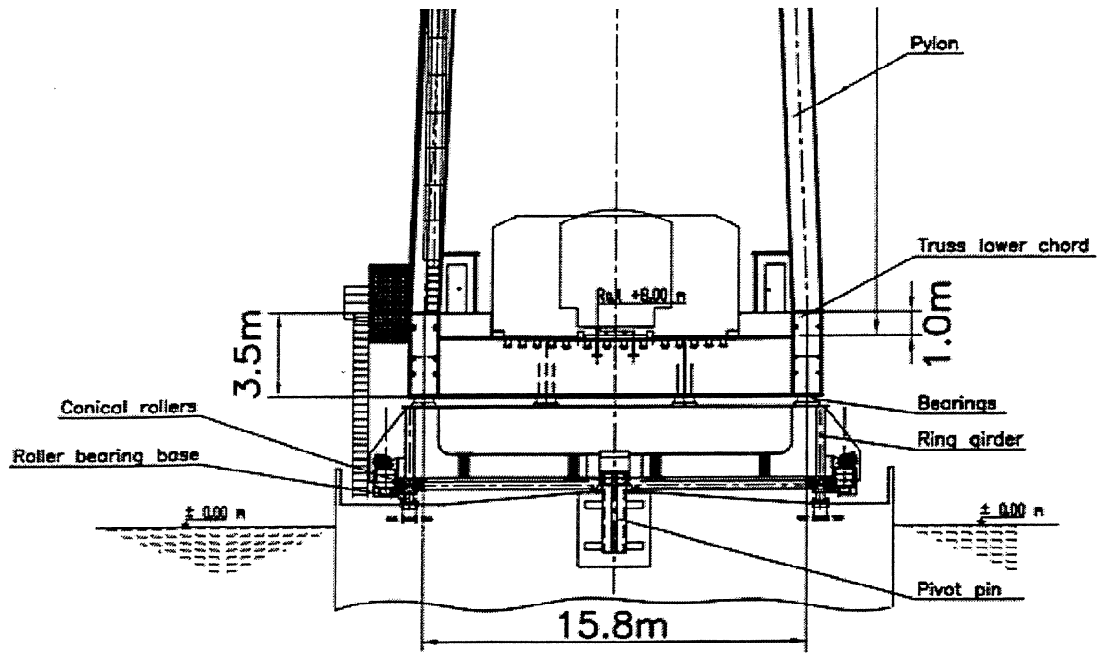

Figure 3: Cross Section at Pylon (Ref. 6)

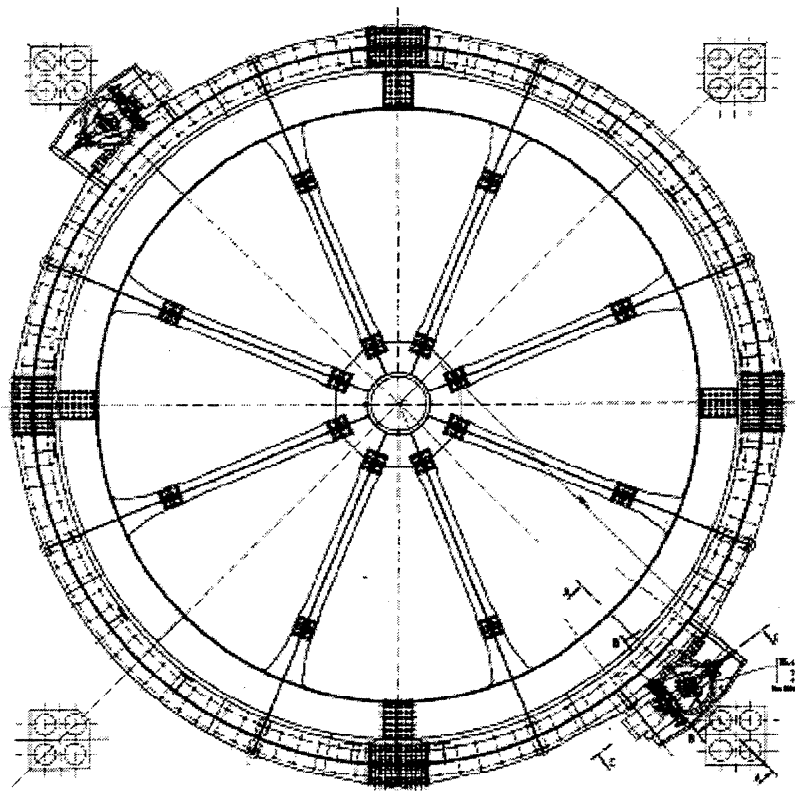

Figure 4: Diagrammatic Representation of the Slewing Gear (Ref. 3)

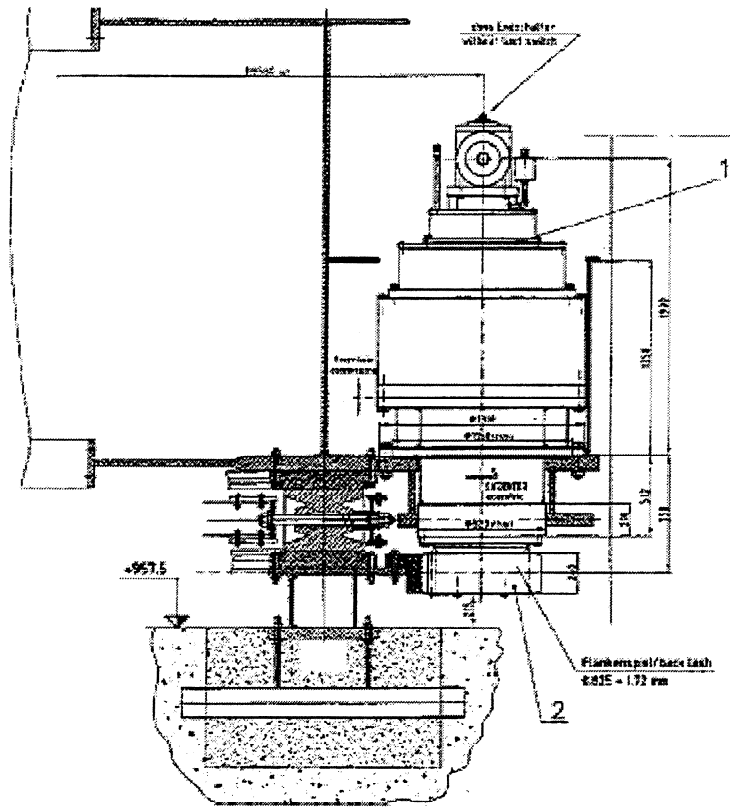

Figure 5: Slewing Gear With Pinion (Ref. 3)

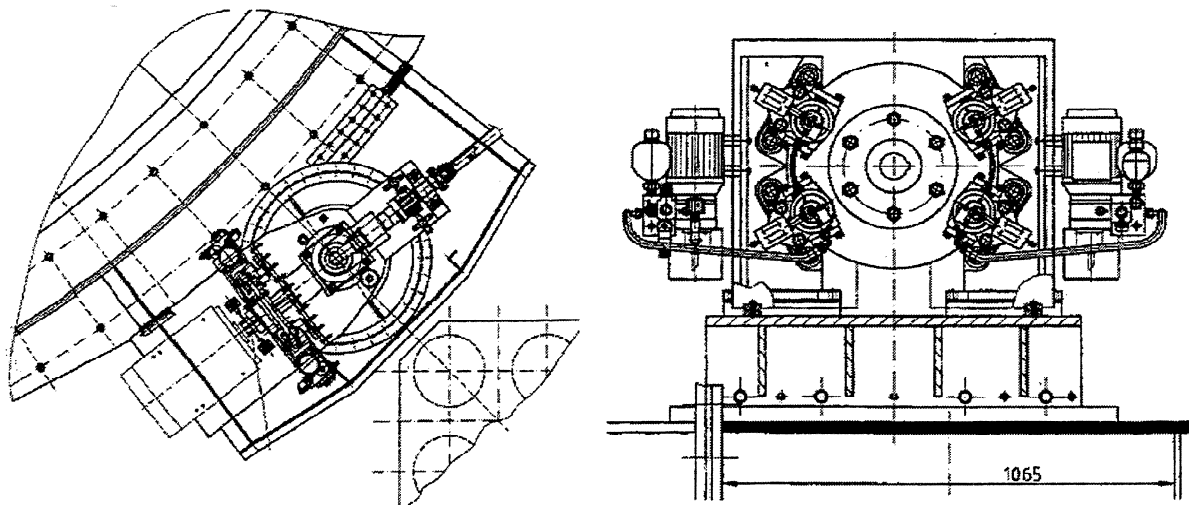

Figure 6: Top View of Drive With Brakes (Ref. 3)

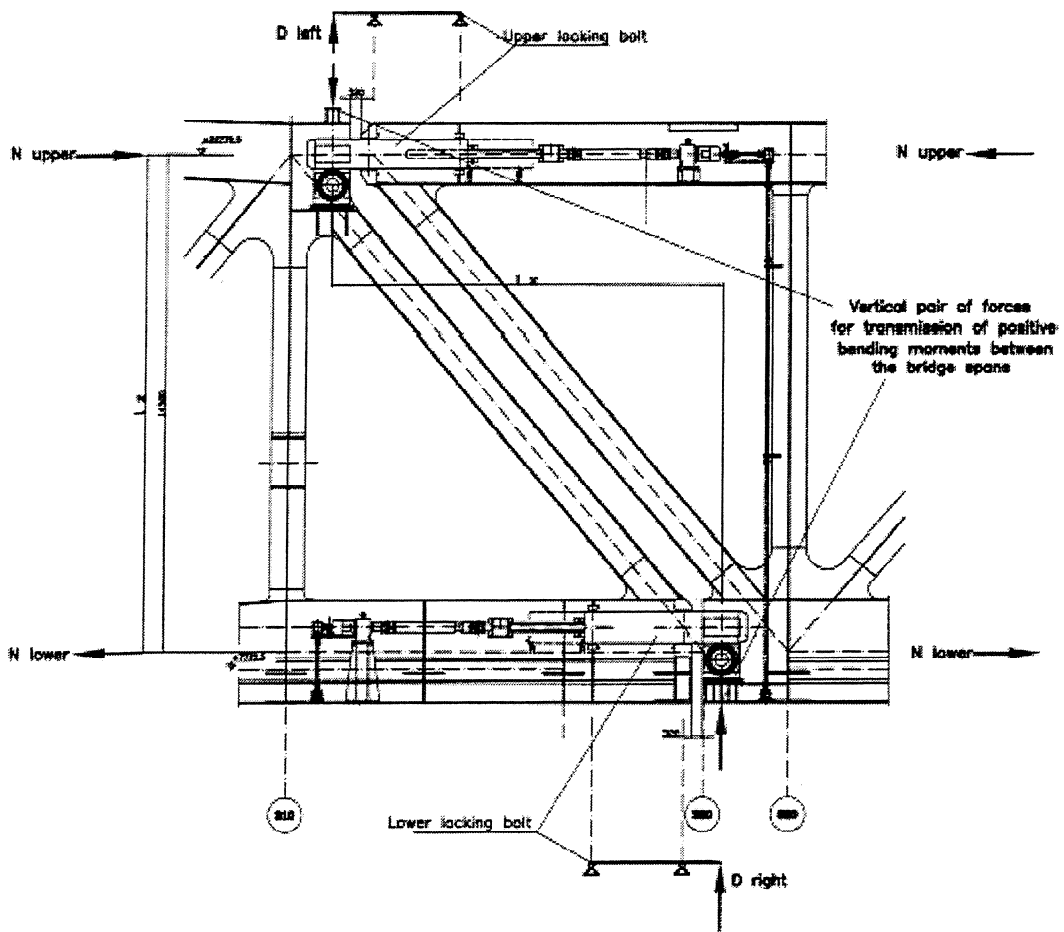

Figure 7: Longitudinal Section of the Centre Locking System (Ref. 6)

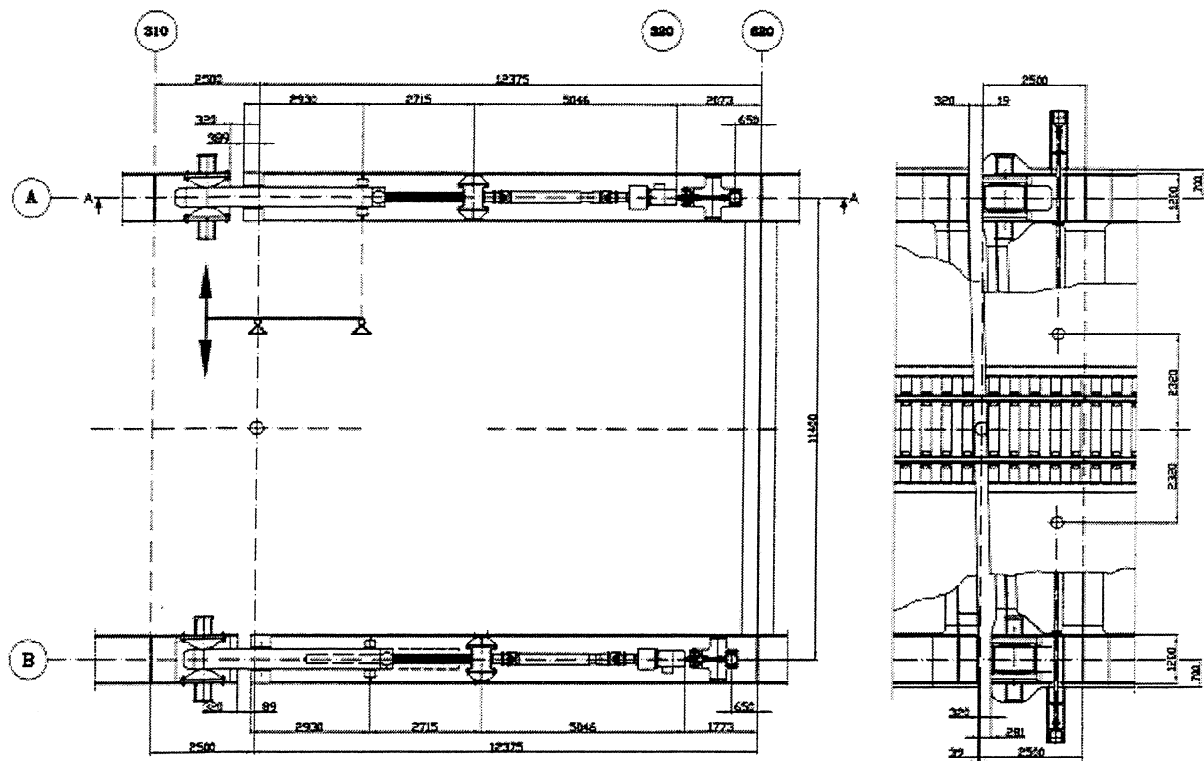

Figure 8: Horizontal Section of the Locking System (Ref. 6)

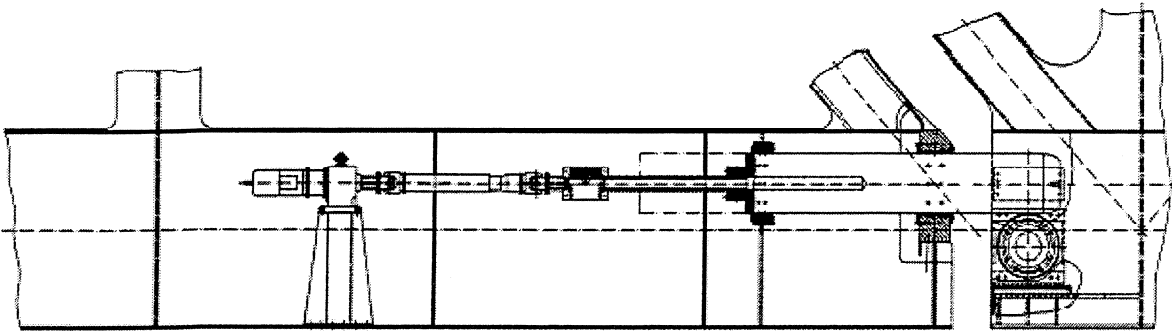

Figure 9: Detail of Bridge Centre Locking (Ref. 7)

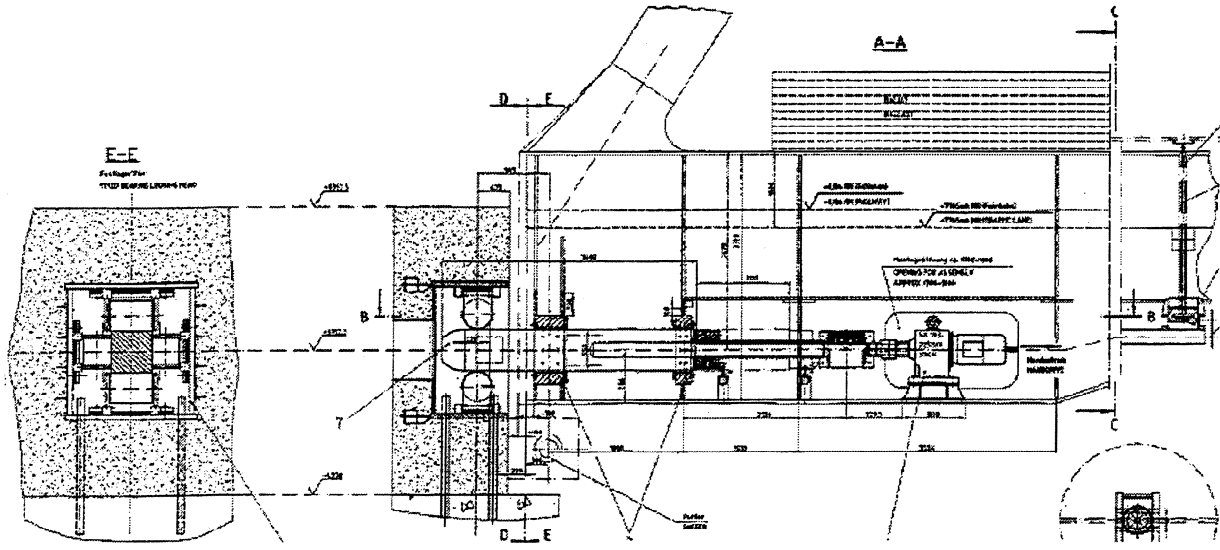

Figure 10: End Locking Device (Ref. 3)