

Chipyard Framework Architecture

Jerry Zhao

UC Berkeley

jzh@berkeley.edu



Berkeley
Architecture
Research

CHIPYARD

Use Cases

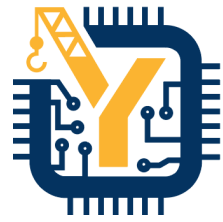

Custom SoC architecture
New blocks + reusing
existing blocks

RTL Simulation running test binaries/micro-benchmarks

FPGA-accelerated simulation running full workloads

FPGA prototyping for fast cool demos

Tape-out the SoC to get actual silicon results



Chipyard Organization

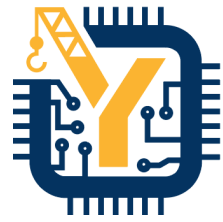

What is Chipyard?

- An organized **framework** for various SoC design tools
- An **IP library** of open-source RISC-V SoC components
- A **methodology** for agile SoC architecture design, exploration, and evaluation

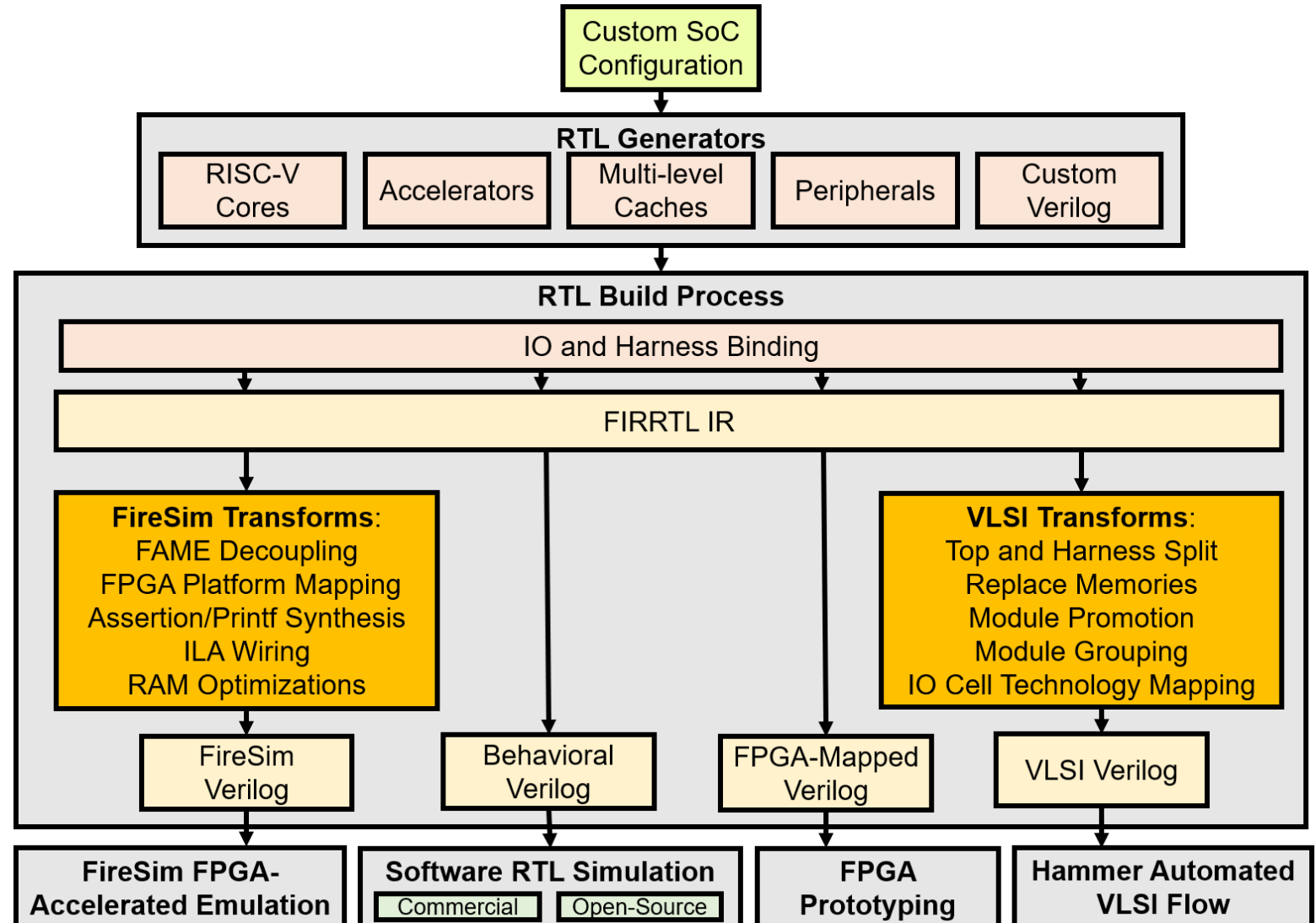

Chipyard Organization

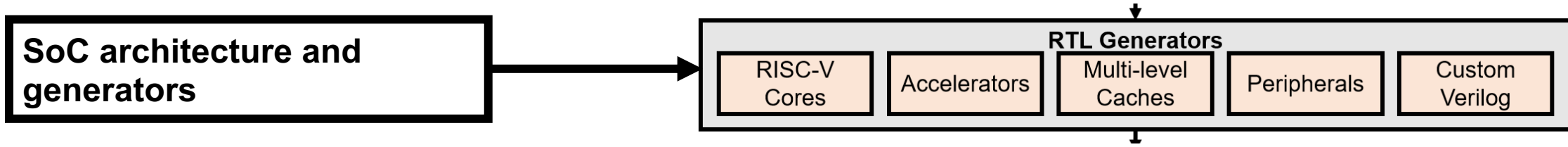

SoC Organization

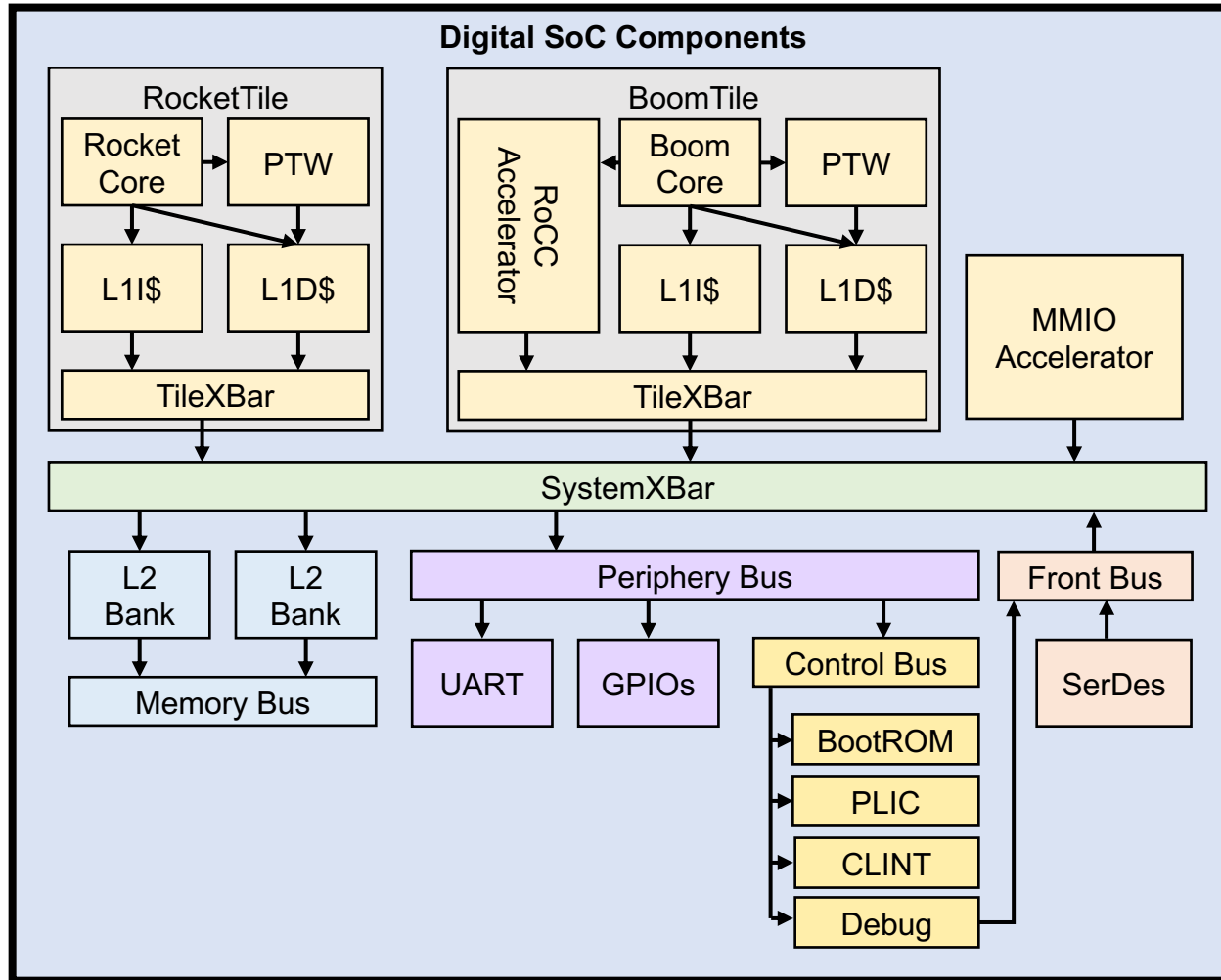
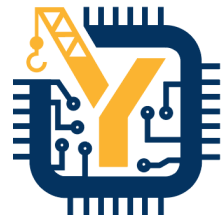

SoC Organization

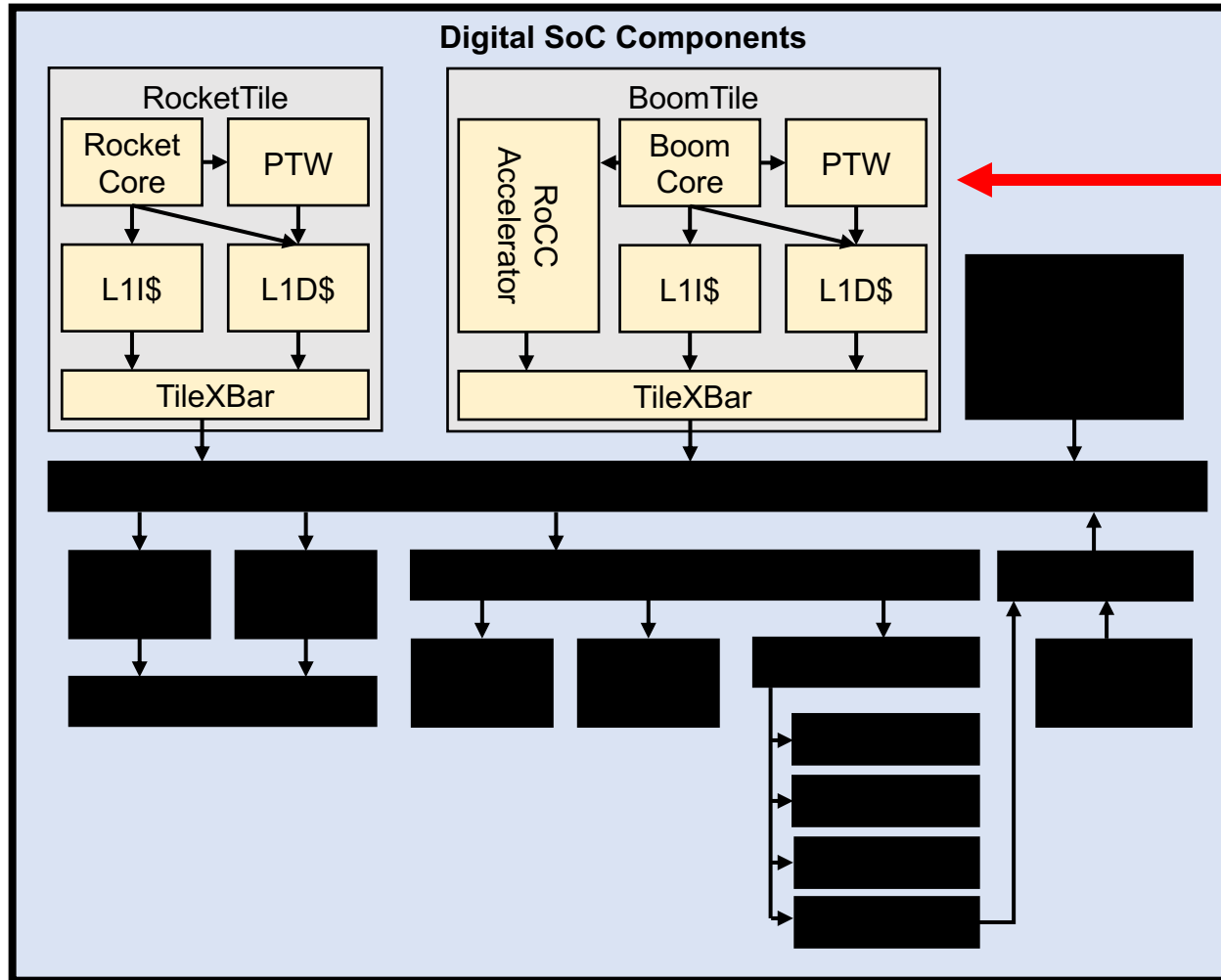
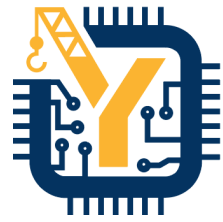

Tiles:

- Each Tile contains a RISC-V core and private caches
- Several varieties of Cores supported
- Interface supports integrating your own RISC-V core implementation



Rocket and BOOM

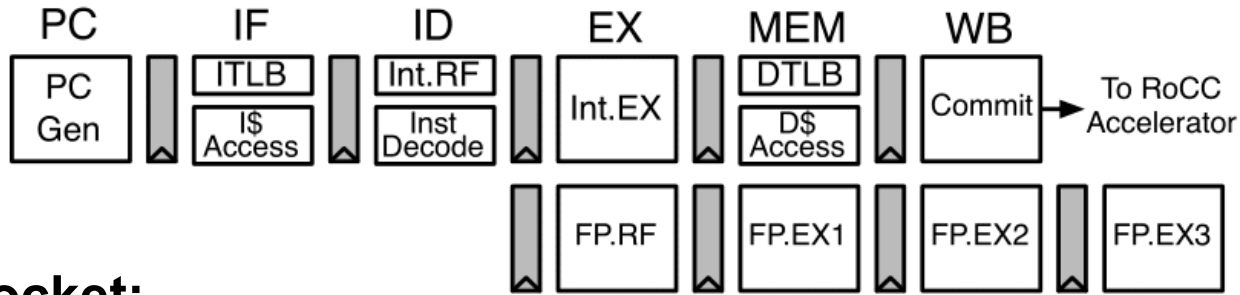

Rocket:

- First open-source RISC-V CPU
- In-order, single-issue RV64GC core
- Efficient design point for low-power devices

SonicBOOM:

- Superscalar out-of-order RISC-V CPU
- Advanced microarchitectural features to maximize IPC
- TAGE branch prediction, OOO load-store-unit, register renaming
- High-performance design point for general-purpose systems

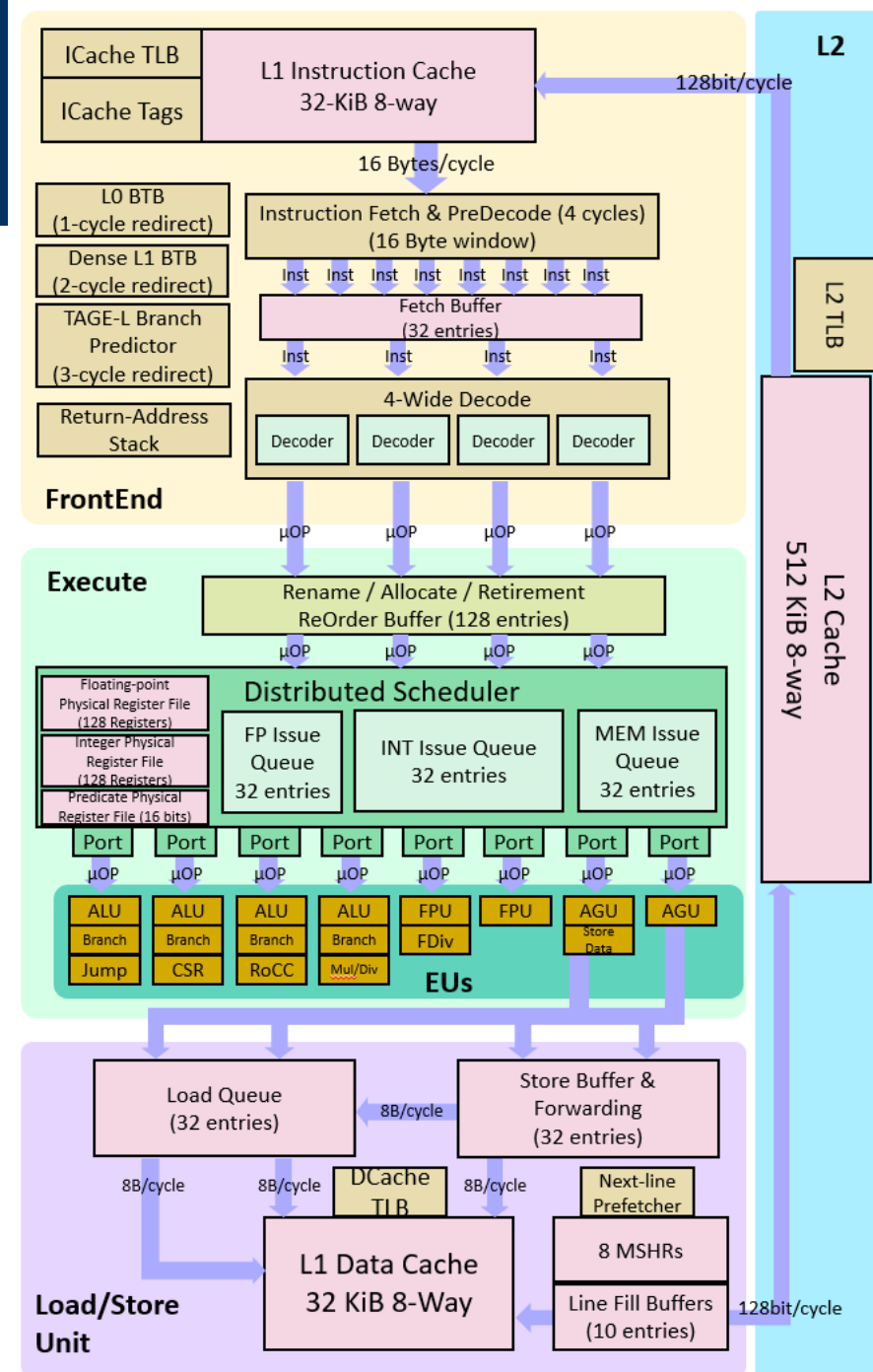

Rocket and BOOM

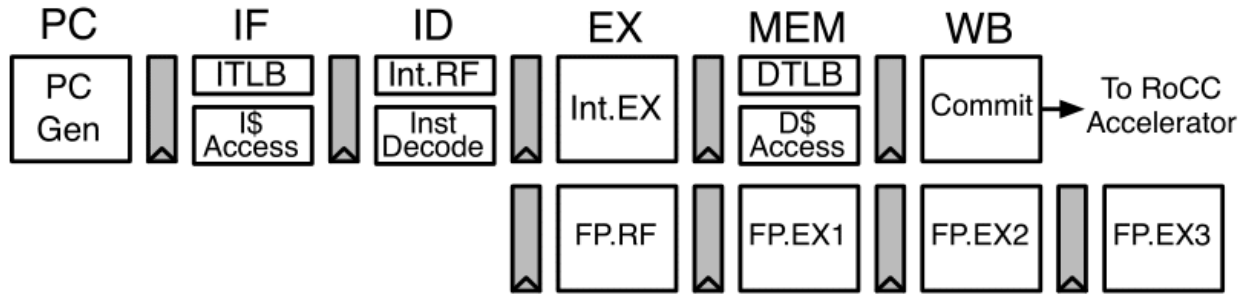

Rocket and SonicBOOM:

- Support RV64GC ISA profile
- Boots off-the-shelf RISC-V Linux distros (buildroot, Fedora, etc.)
- Fully synthesizable, tapeout-proven
- Described in Chisel
- Fully open-sourced

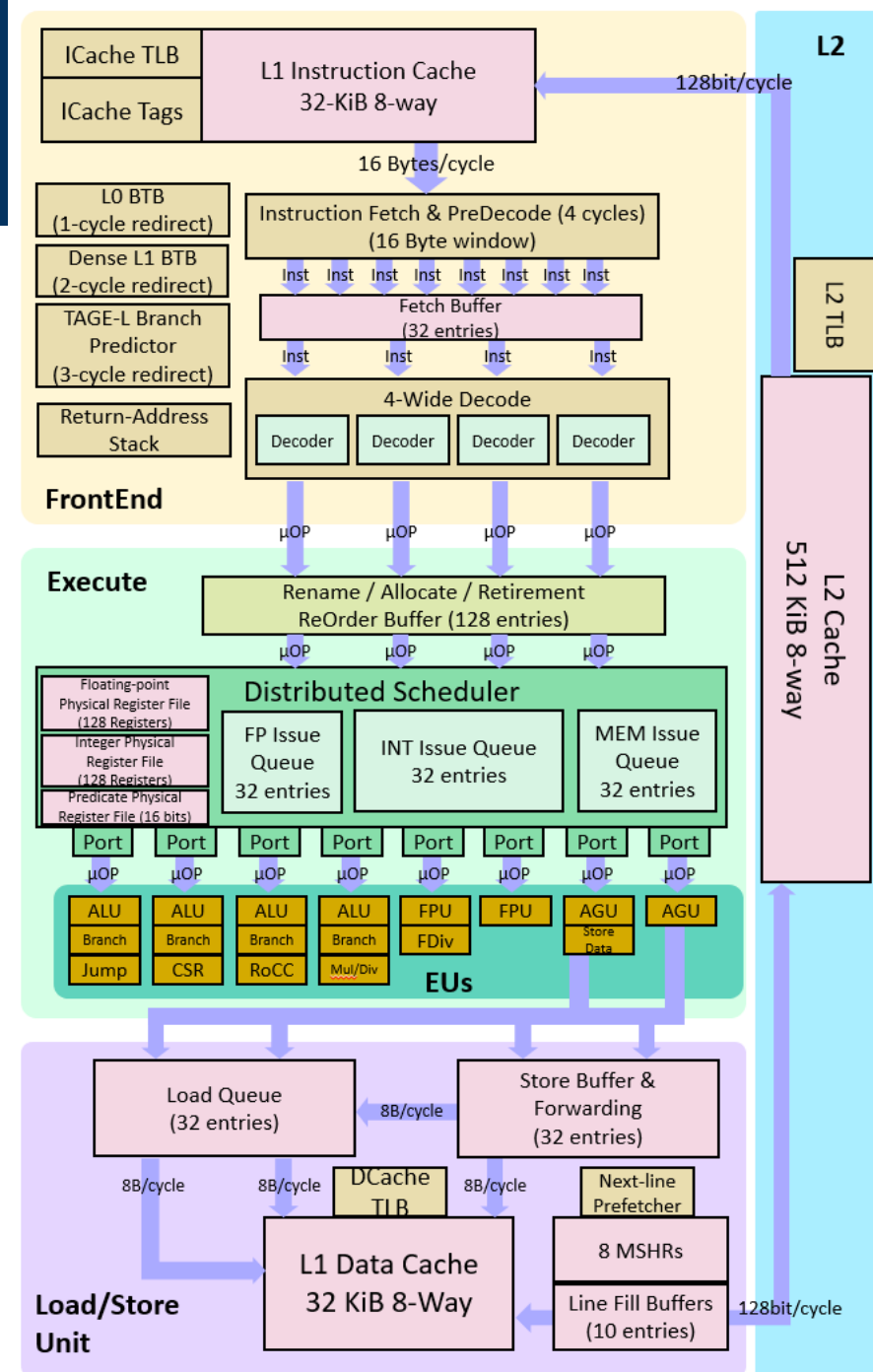

PULP Cores in Chipyard

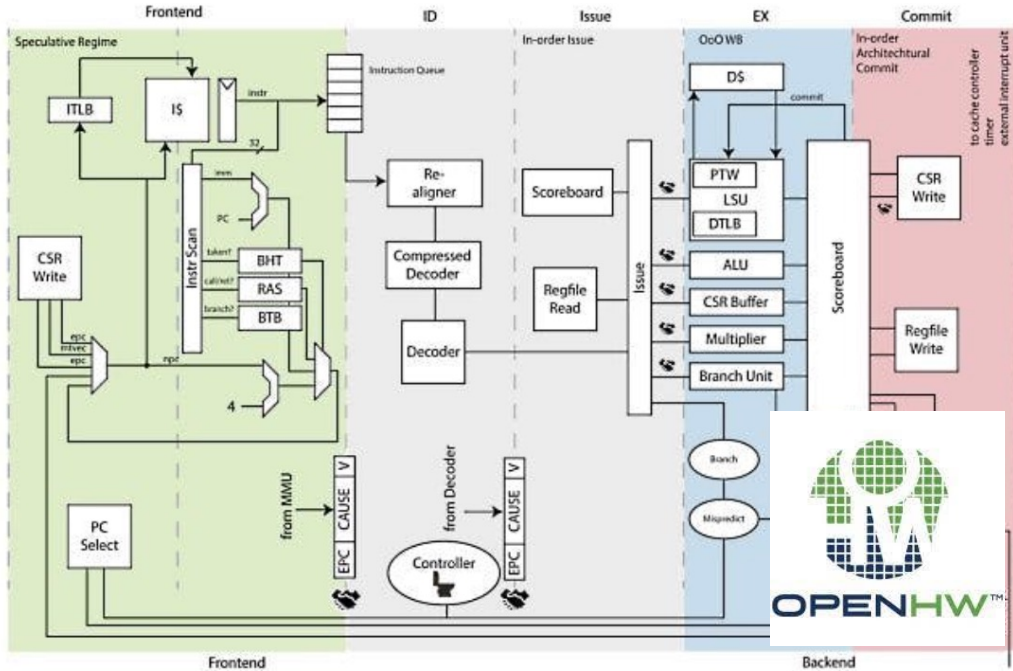
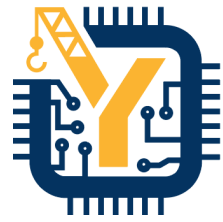

CVA6 (Formerly Ariane):

- RV64IMAC 6-stage single-issue in-order core
- Open-source
- Implemented in SystemVerilog
- Developed at ETH Zurich as part of PULP,
- Now maintained by OpenHWGroup

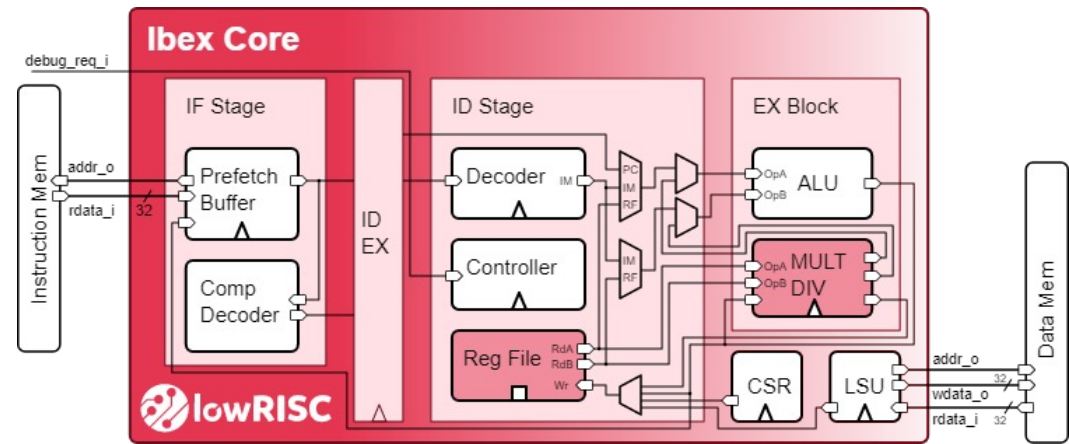

Ibex (Formerly Zero-RISCY):

- RV64IMC 2-stage single-issue in-order core
- Open-source
- Implemented in SystemVerilog
- Developed at ETH Zurich as part of PULP
- Now maintained by lowRISC

Sodor Educational Cores

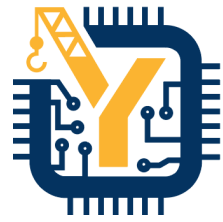

Sodor Core Collection

- Collection of RV32IM cores for teaching and education
- 1-stage, 2-stage, 3-stage, 5-stage implementations
- Micro-coded “bus-based” implementation
- Used in introductory computer architecture courses at Berkeley

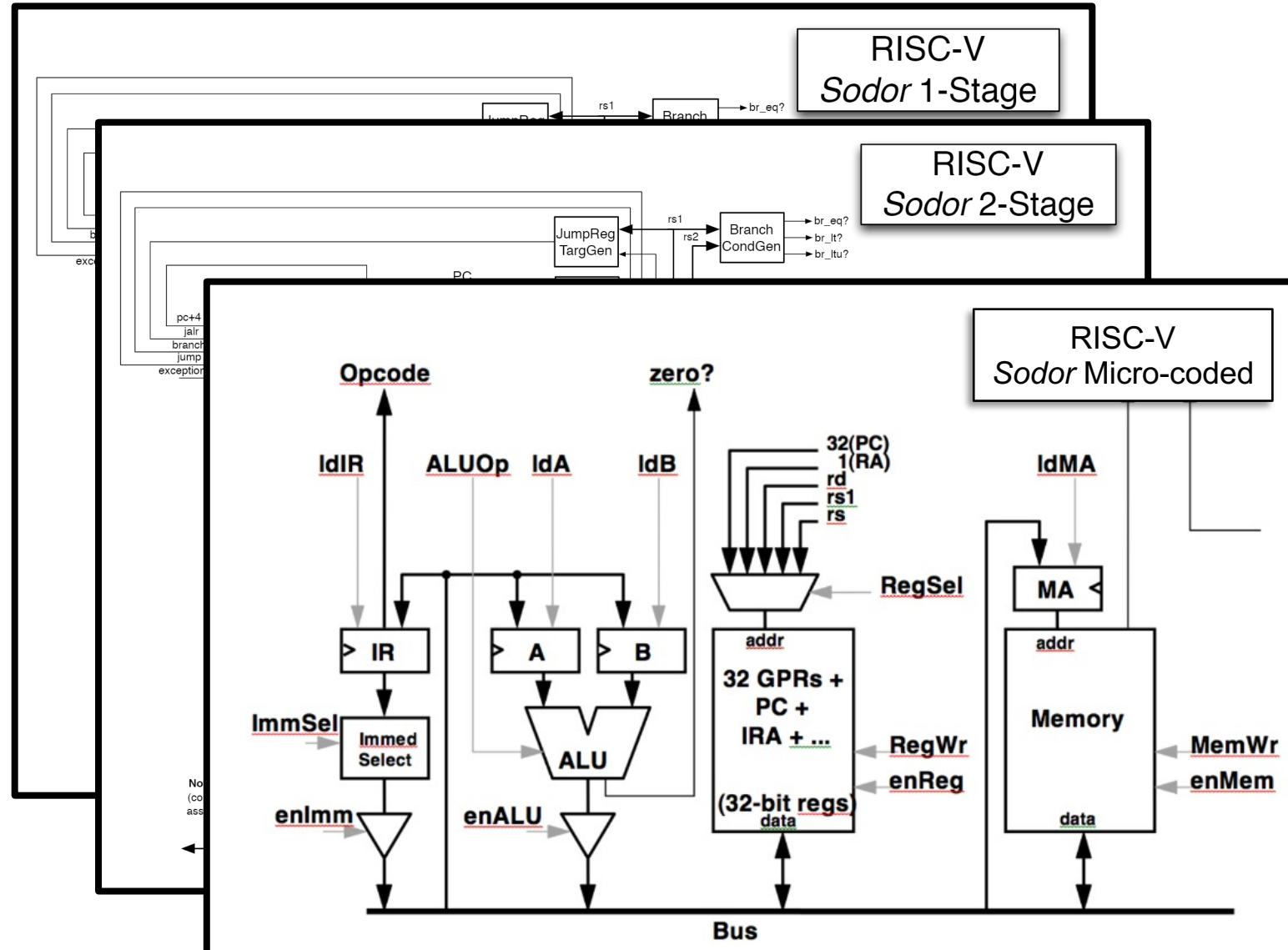

SoC Organization

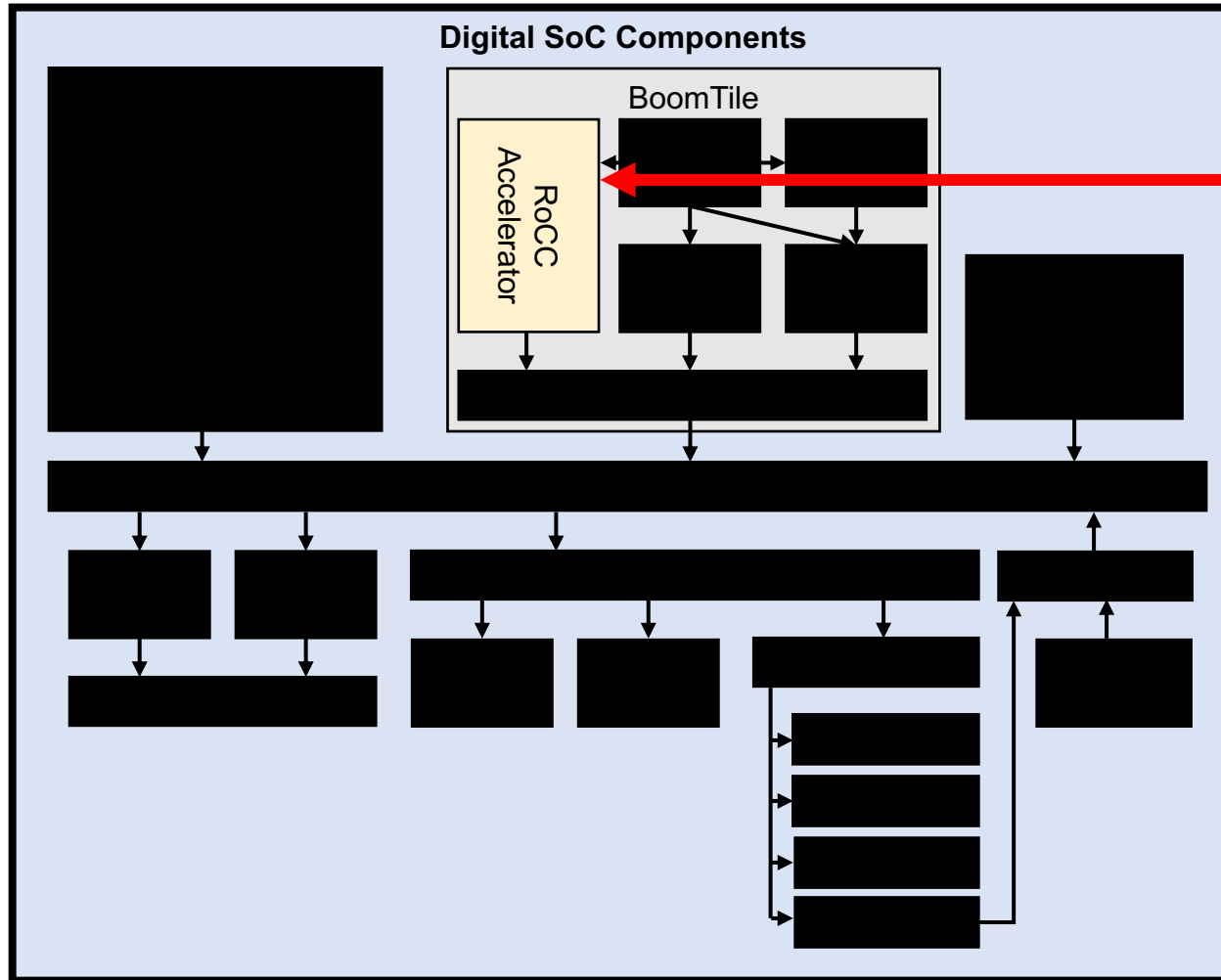
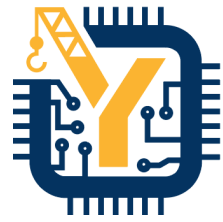

RoCC Accelerators:

- Tightly-coupled accelerator interface
- Attach custom accelerators to Rocket or BOOM cores



RoCC Accelerators

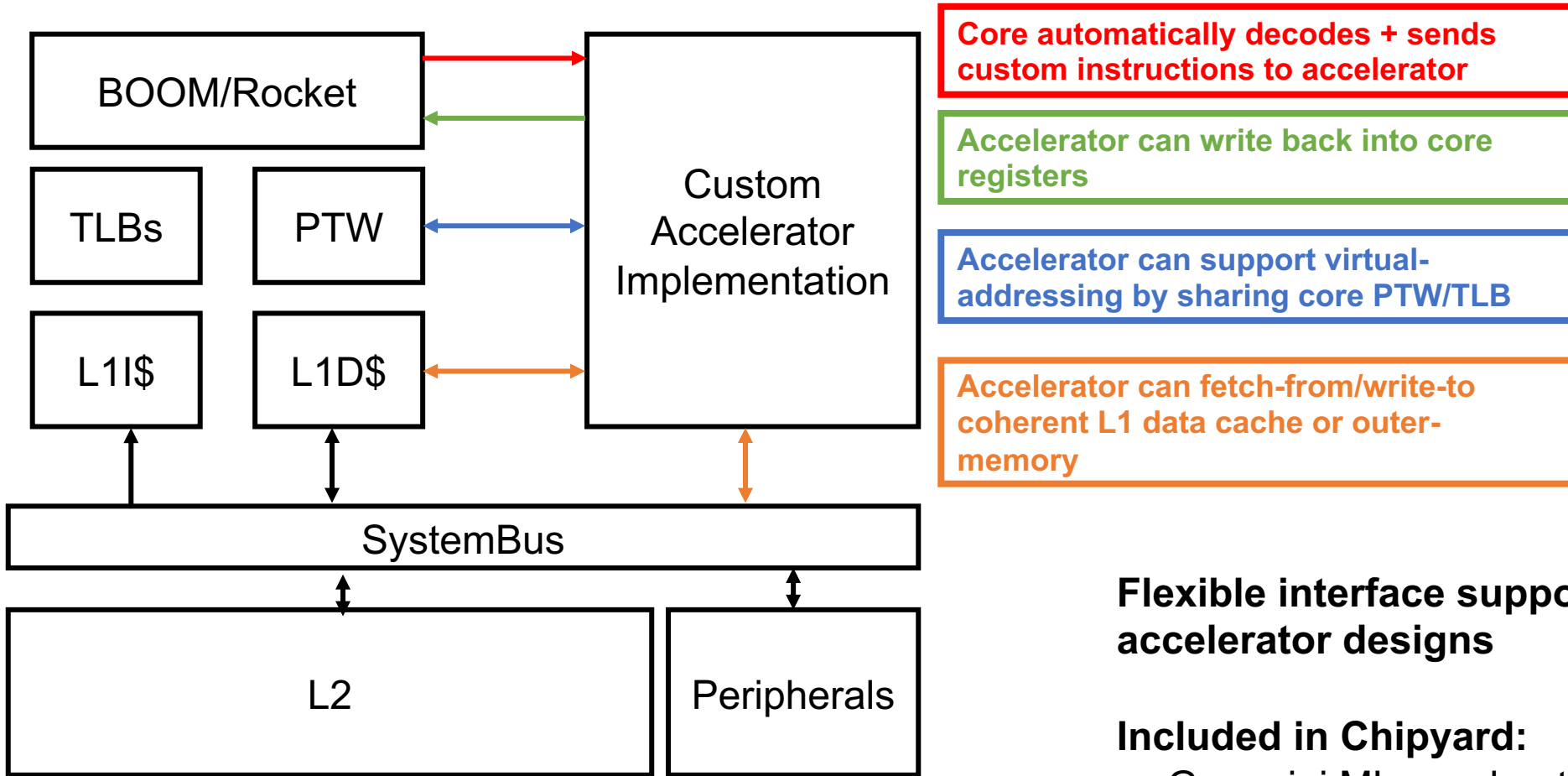

Flexible interface supports a variety of accelerator designs

Included in Chipyard:

- Gemini ML accelerator
- Hwacha vector accelerator
- SHA3 accelerator



MMIO Accelerators

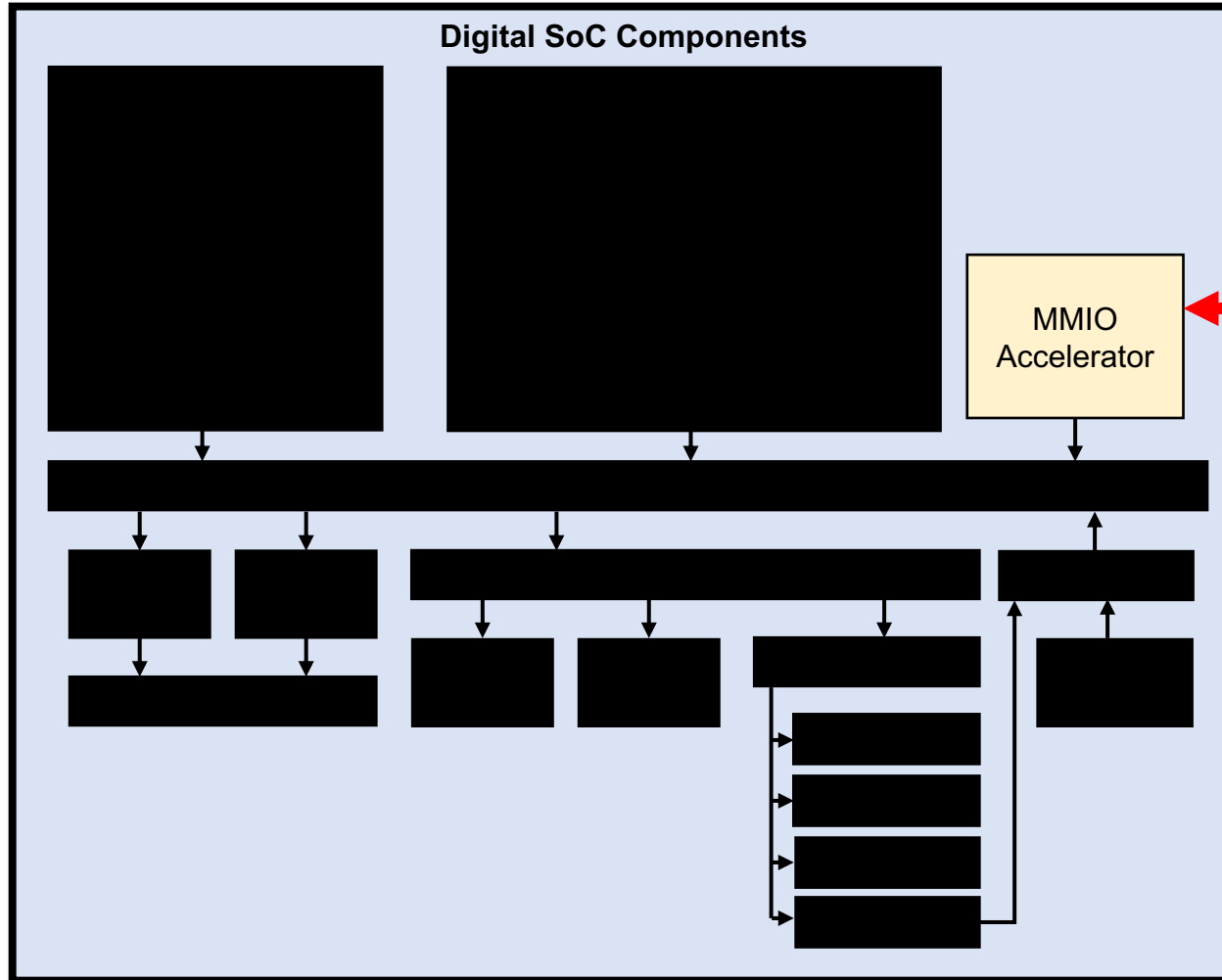
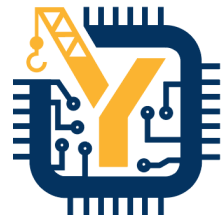

MMIO Accelerators:

- Controlled by MMIO-mapped registers
- Supports DMA to memory system
- Examples:
 - Nvidia NVDLA accelerator
 - FFT accelerator generator



SoC Organization

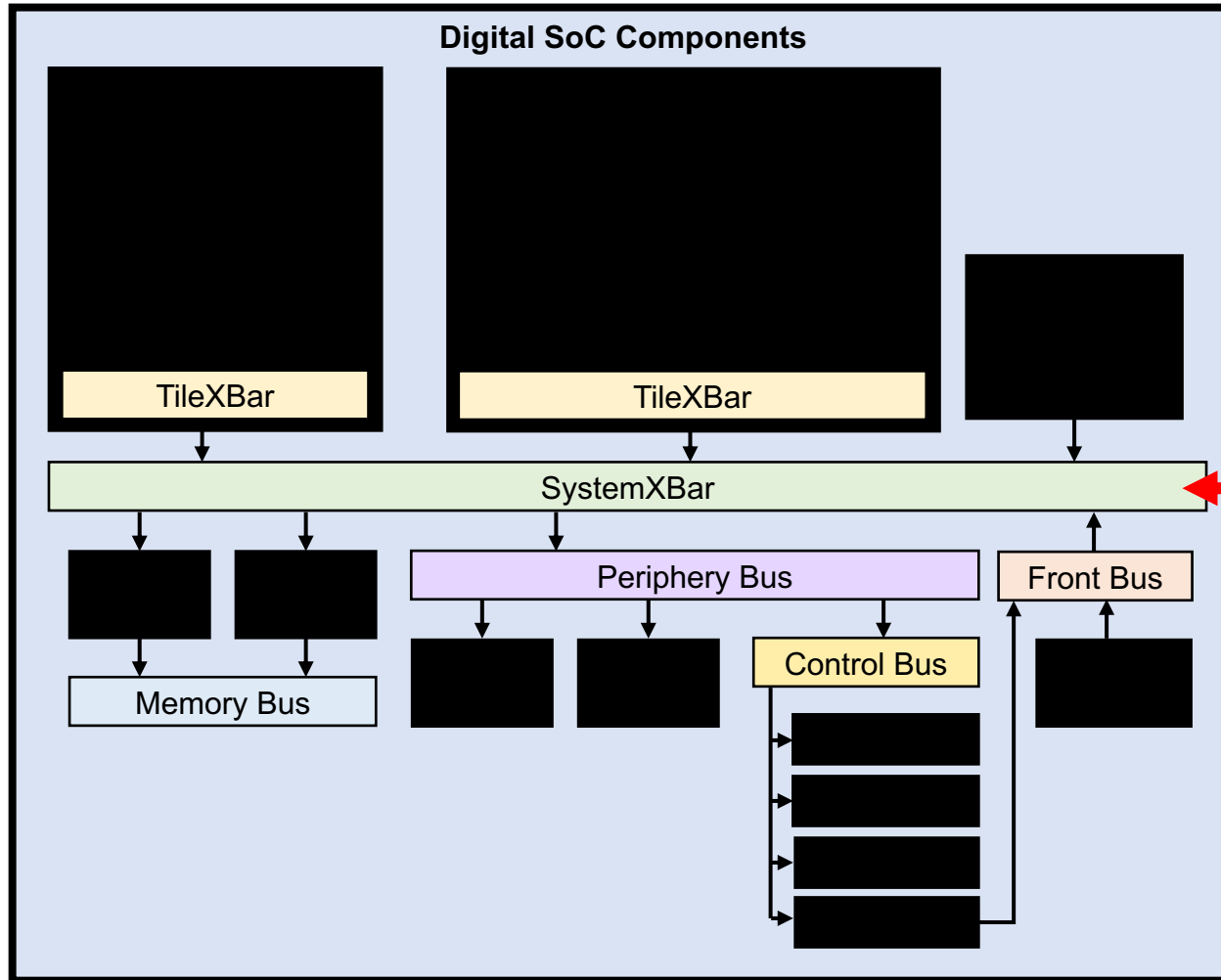
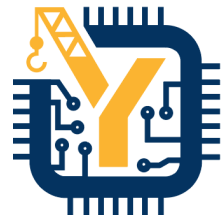

TileLink Standard:

- TileLink is open-source chip-scale interconnect standard
- Comparable to AXI/ACE
- Supports multi-core, accelerators, peripherals, DMA, etc

Interconnect IP:

- Library of TileLink RTL generators provided in RocketChip
- RTL generators for crossbar-based buses
- Width-adapters, clock-crossings, etc.
- Adapters to AXI4, APB



SoC Organization

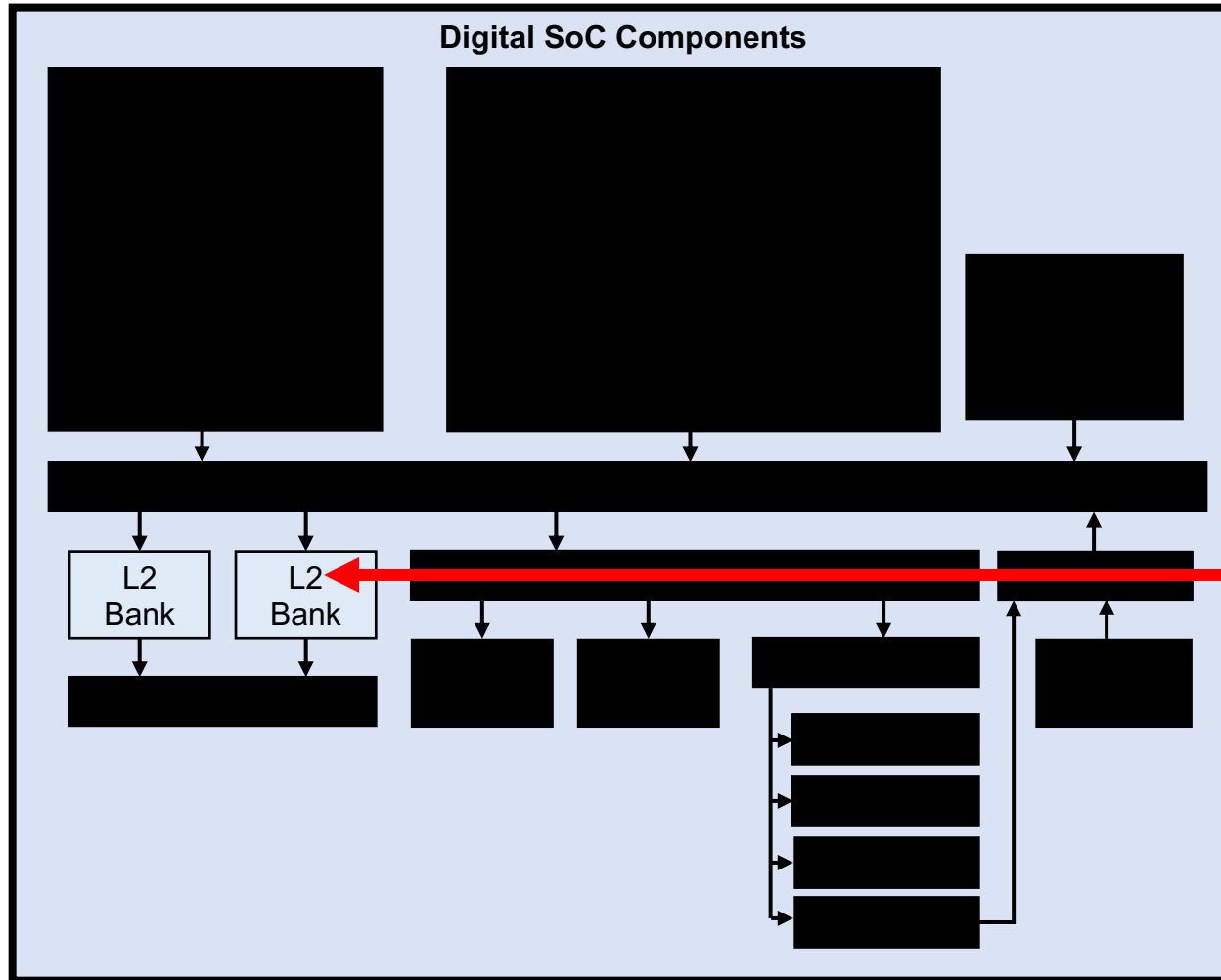
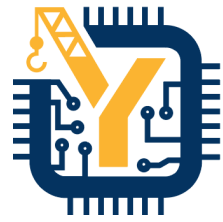

Shared memory:

- Open-source TileLink L2 developed by SiFive
 - Directory-based coherence with MOESI-like protocol
 - Configurable capacity/banking
- Support broadcast-based coherence in no-L2 systems
- Support incoherent memory systems



SoC Organization

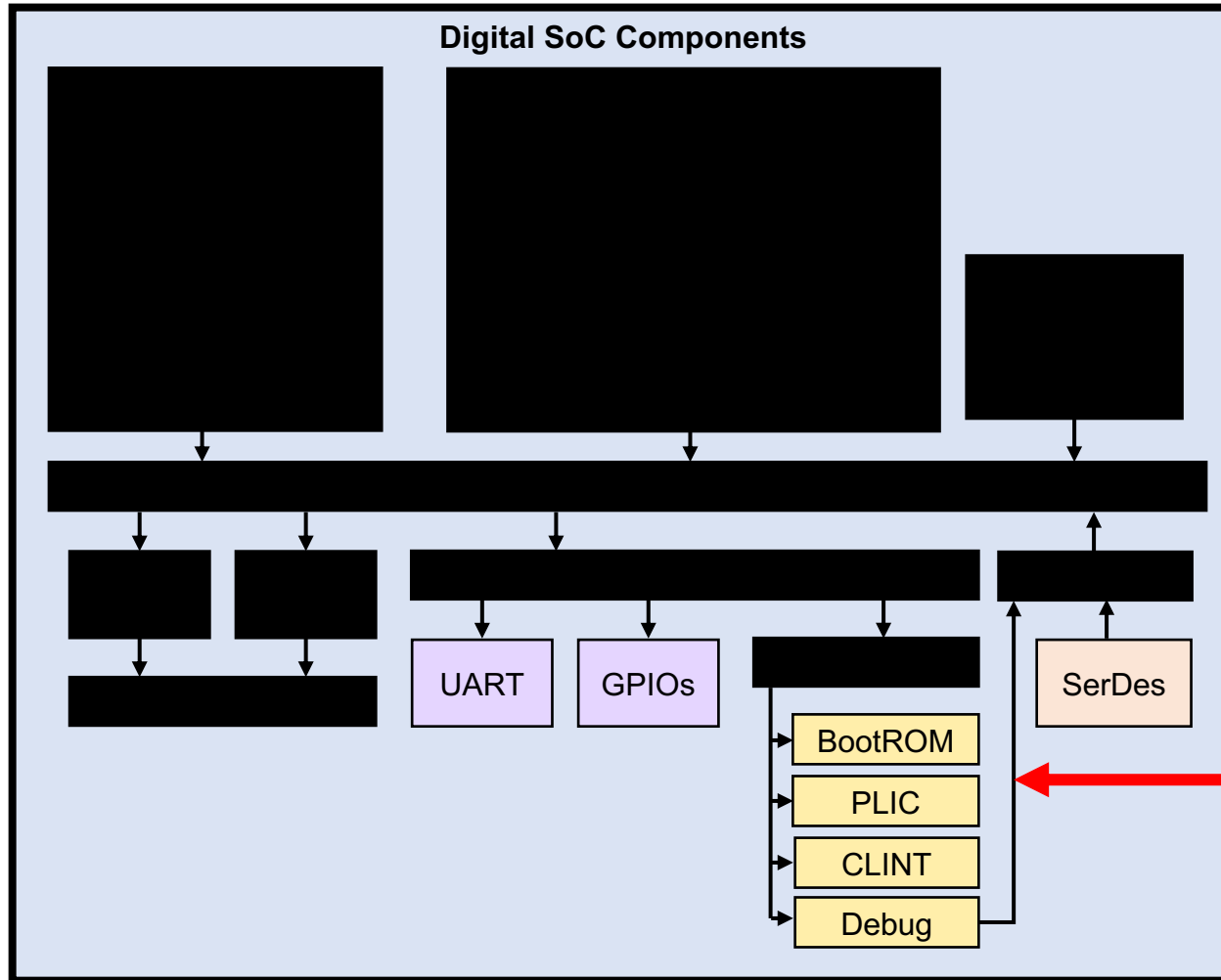
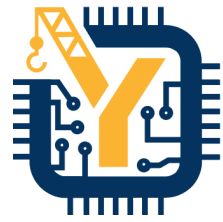

Peripherals and IO:

- Open-source RocketChip + SiFive blocks:
 - Interrupt controllers
 - JTAG, Debug module, BootROM
 - UART, GPIOs, SPI, I2C, PWM, etc.
- TestChipIP: useful IP for test chips
 - Clock-management devices
 - SerDes
 - Scratchpads



SoC Organization

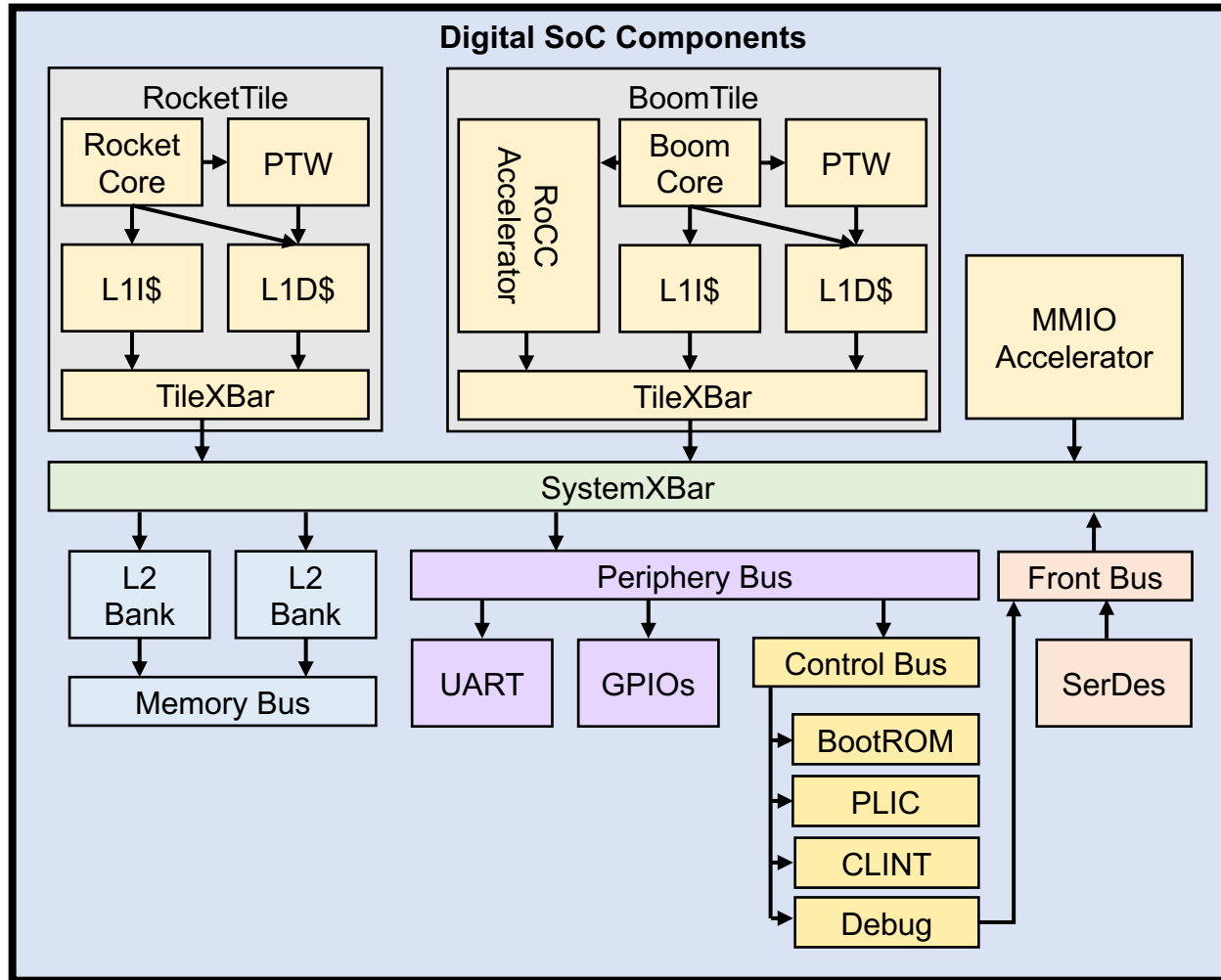
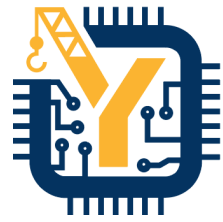

Chisel

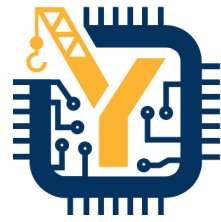

- Chisel – Hardware Construction Language built on Scala

- What Chisel **IS NOT**:

- **NOT** Scala-to-gates
- **NOT** HLS
- **NOT** tool-oriented language

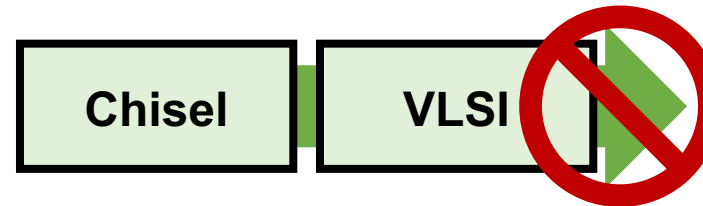

- What Chisel **IS**:

- Productive language for **generating** hardware
- Leverage **OOP/Functional programming** paradigms
- Enables design of **parameterized generators**
- **Designer-friendly**: low barrier-to-entry, high reward
- **Backwards-compatible**: integrates with Verilog black-boxes

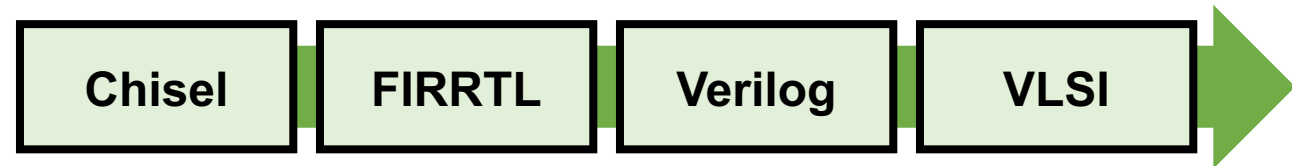

Chisel Example

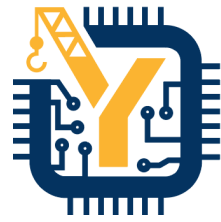

```
// Generalized FIR filter parameterized by coefficients
class FirFilter(bitWidth: Int, coeffs: Seq[Int]) extends Module {
  val io = IO(new Bundle {
    val in = Input(UInt(bitWidth.W))
    val out = Output(UInt(bitWidth.W))
  })
  val zs = Wire(Vec(coeffs.length, UInt(bitWidth.W)))
  zs(0) := io.in
  for (i <- 1 until coeffs.length) {
    zs(i) := RegNext(zs(i-1))
  }
  val products = zs zip coeffs map {
    case (z, c) => z * c.U
  }
  io.out := products.reduce(_ + _)
}
```

Flexible parameters:

- Enables development of highly flexible, parameterized HW generators

HDL, not HLS:

- Designers reason about wires, registers, gates, IO, etc.
- Familiar Wire, Reg, IO constructs makes Chisel beginner-friendly

Designer-friendly features

- Powerful OOP/functional programming paradigms
- Strict type-checking encourages “correct-by-construction” design



Learning Chisel

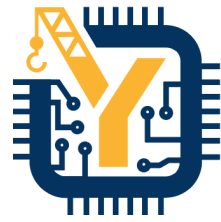

This tutorial does not expect any familiarity of Chisel

Many resources for learning Chisel

- Step-by-step tutorial:
<https://github.com/ucb-bar/chisel-tutorial>
- Jupyter notebook:
<https://github.com/freechipsproject/chisel-bootcamp>
- Chisel Textbook:
<https://www.imm.dtu.dk/~masca/chisel-book.html>

Books › Computers & Technology › Programmir

Look inside ↴

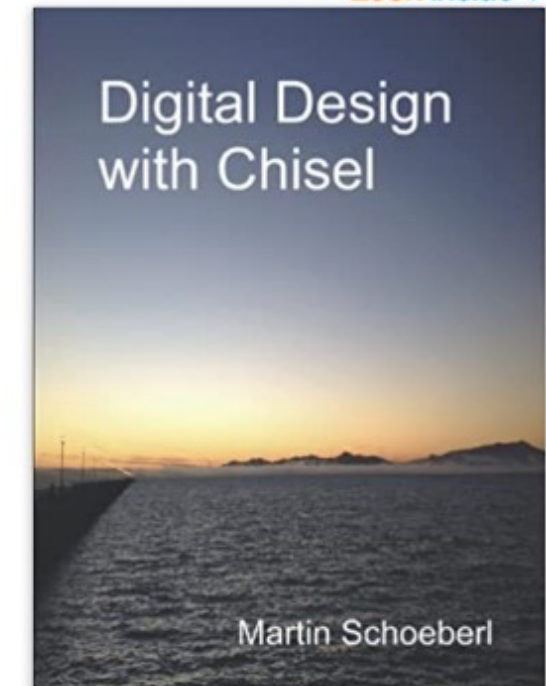

Chipyard Organization

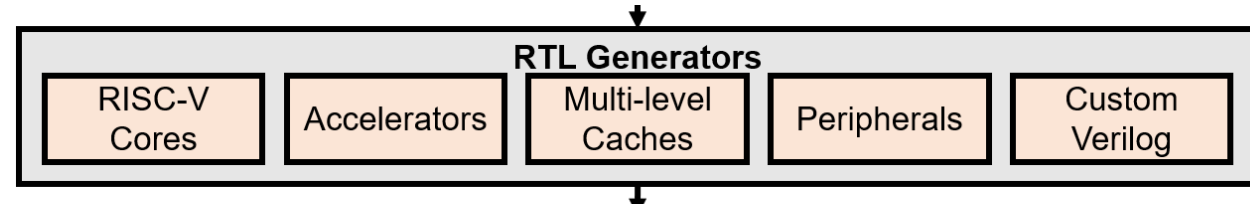
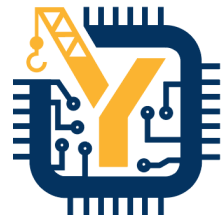

Chipyard Organization

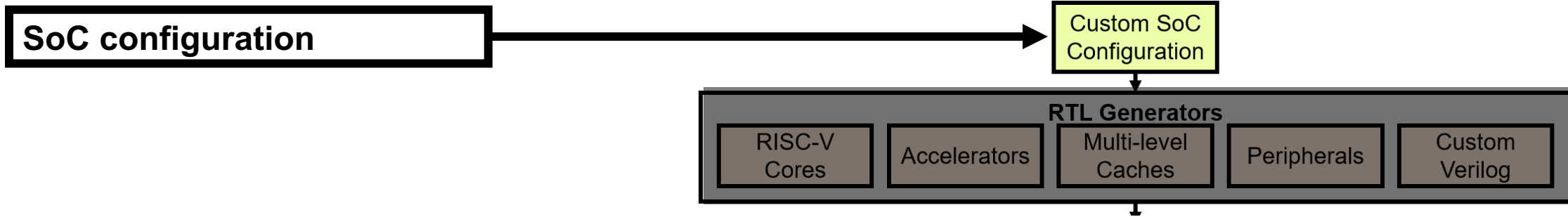
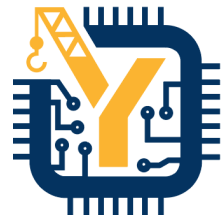

Highly Parameterized Configurations

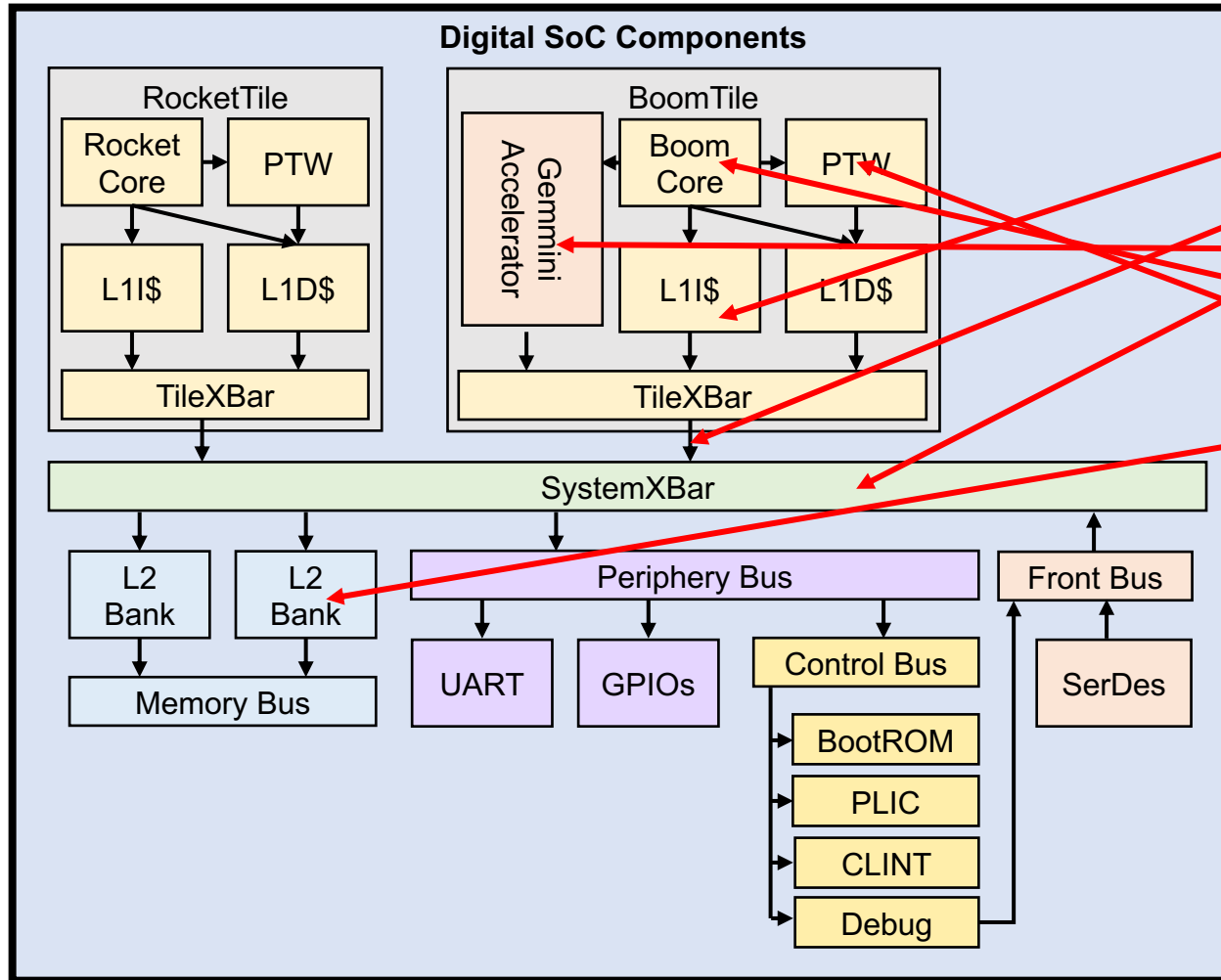
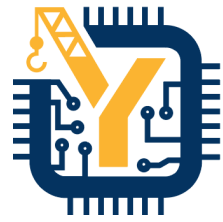

```
class CustomConfig extends Config(  
    new WithL1CacheWays(4) ++  
    new WithAsyncTiles ++  
    new WithSystemBusWidth(128) +  
    new WithFPGemmini ++  
    new With3WideBooms ++  
    new WithL2TLBs(512) ++  
    new WithL2Sets(1024) ++  
  
    new WithDefaultGemmini ++  
    new WithNRocketCores(1) ++  
    new WithNBoomCores(1) ++  
    new WithBootROM ++  
    new WithUART ++  
    new WithJtagDTM ++  
    new WithGPIOs ++  
    new WithInclusiveCache(512) ++  
)
```



Chipyard Organization

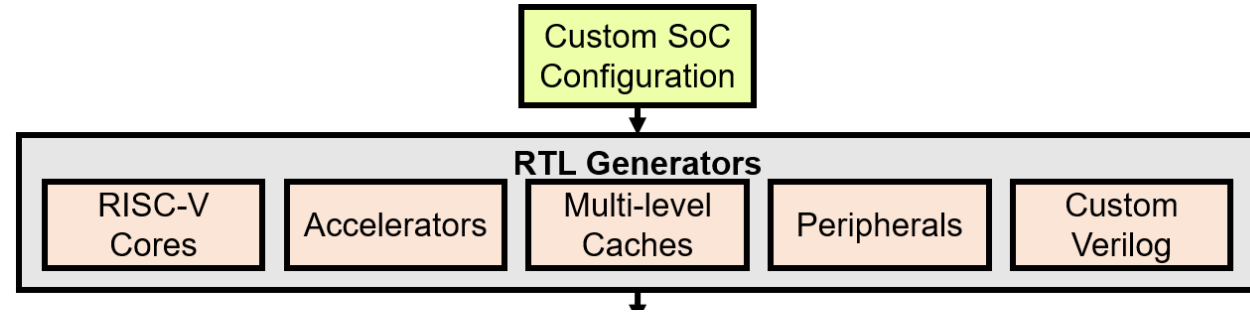
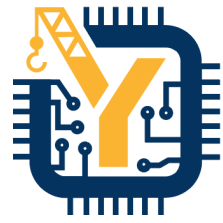

Chipyard Organization

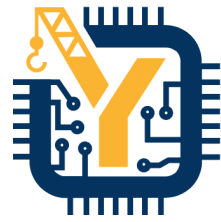

SW RTL Simulation:

- RTL-level simulation with Verilator or VCS

- Hands-on tutorial next

FPGA prototyping:

- Fast, non-deterministic prototypes
- Overview of flow later

Hammer VLSI flow:

- Tapeout a custom config in some process technology
- Overview of flow later

FireSim:

- Fast, accurate FPGA-accelerated simulations
- Hands-on tutorial later

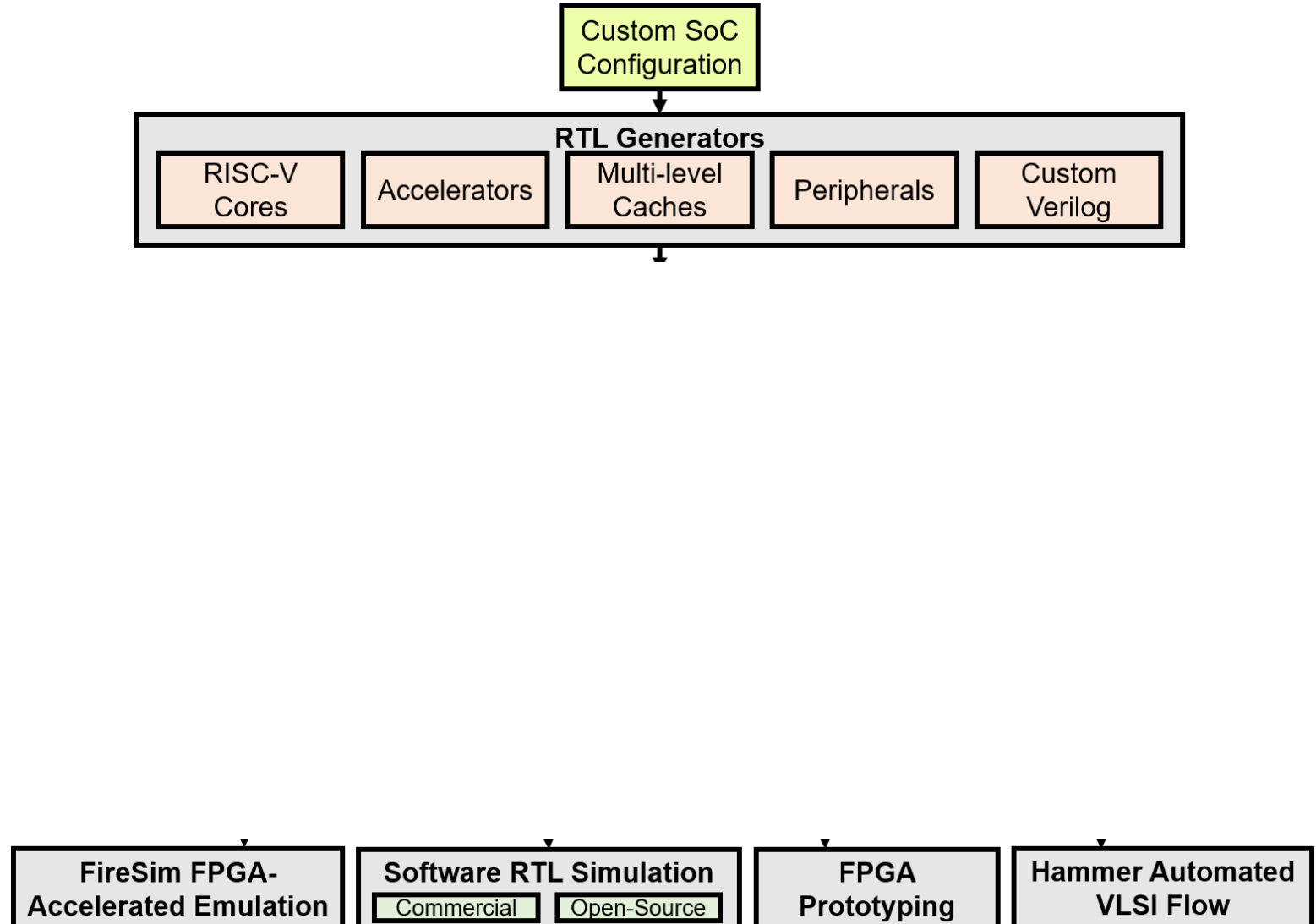

Chipyard Organization

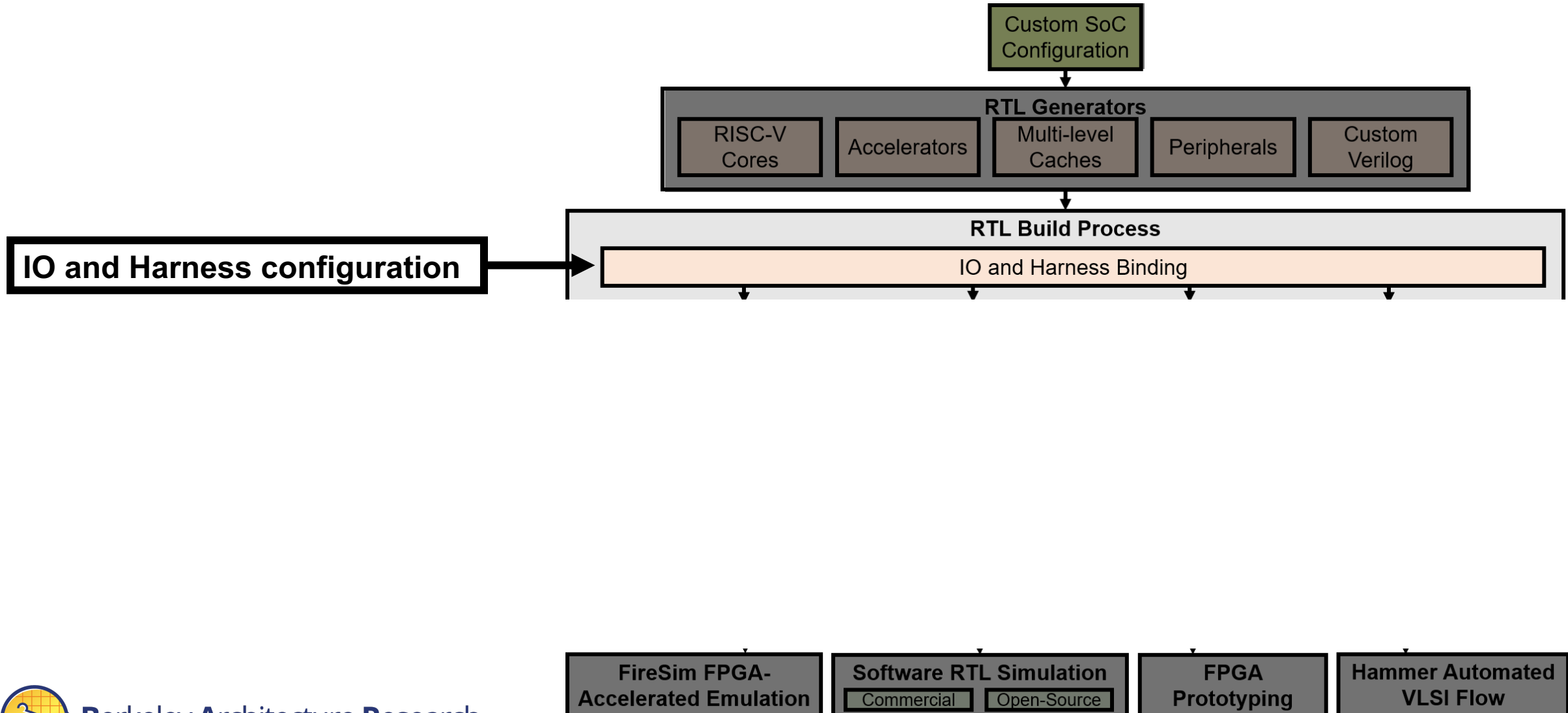
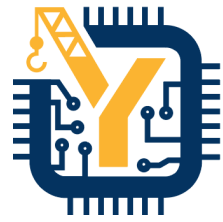

Multipurpose

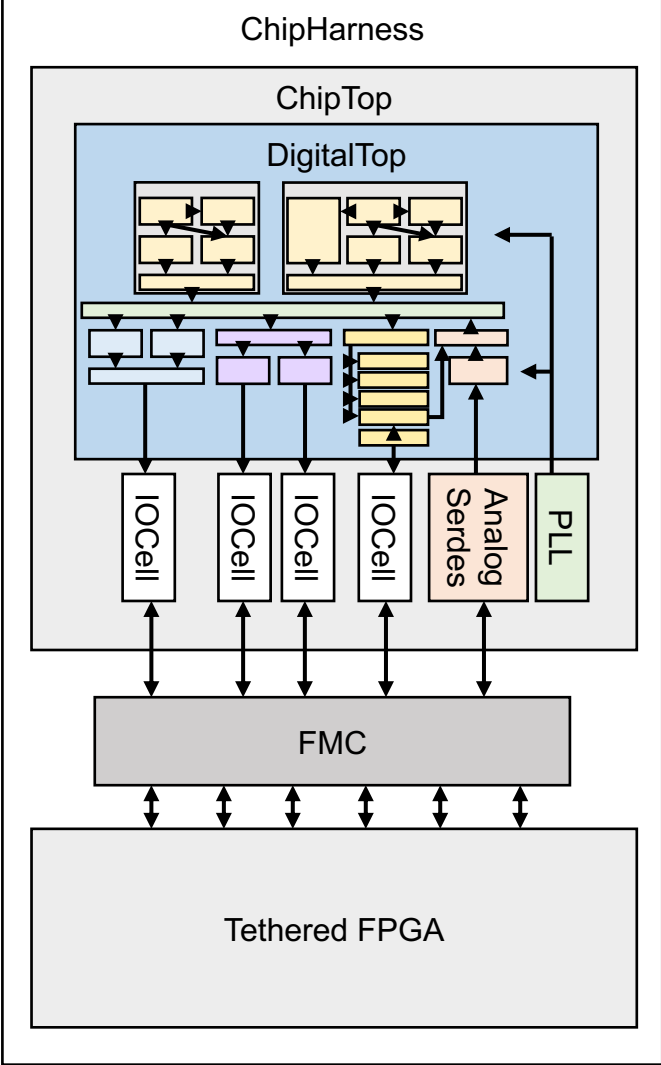
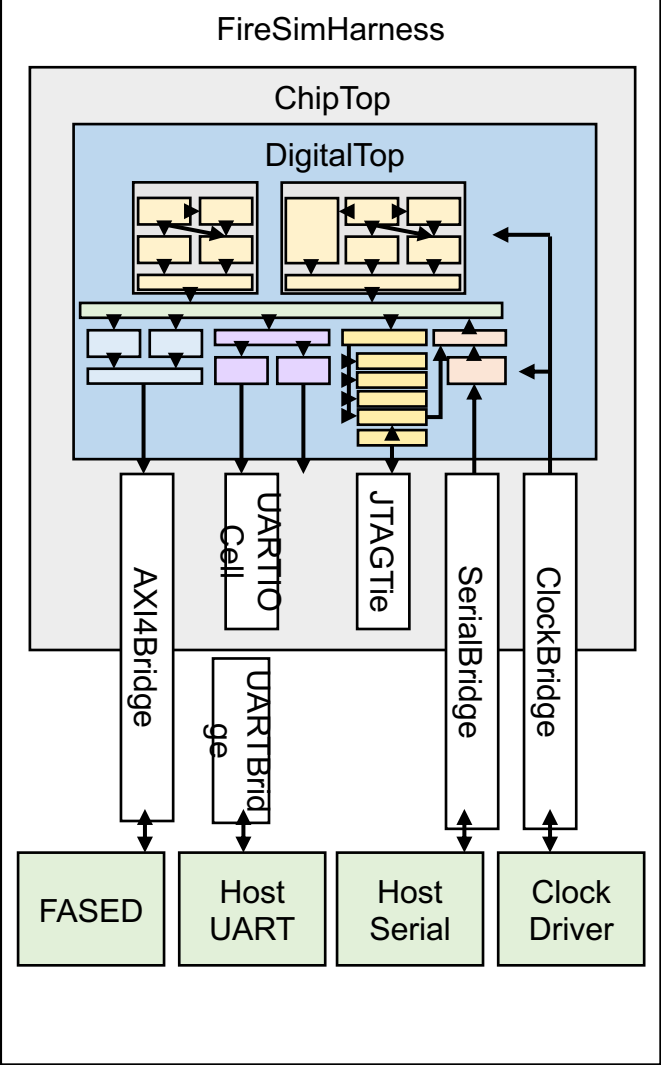
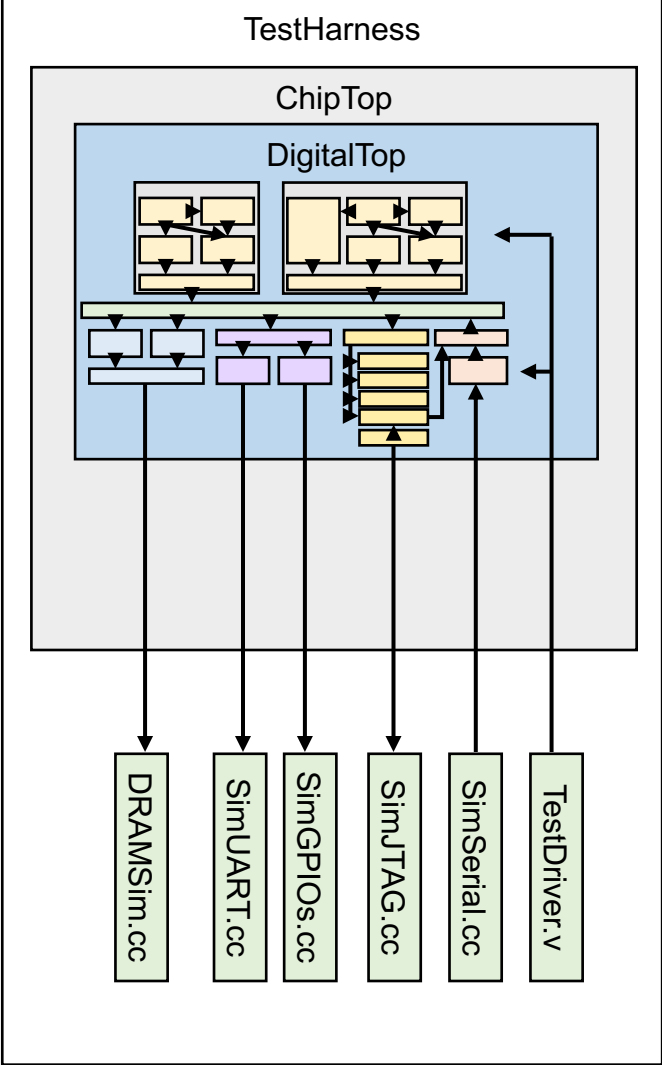
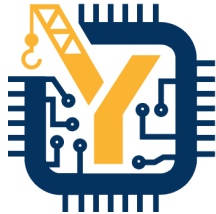

Multipurpose

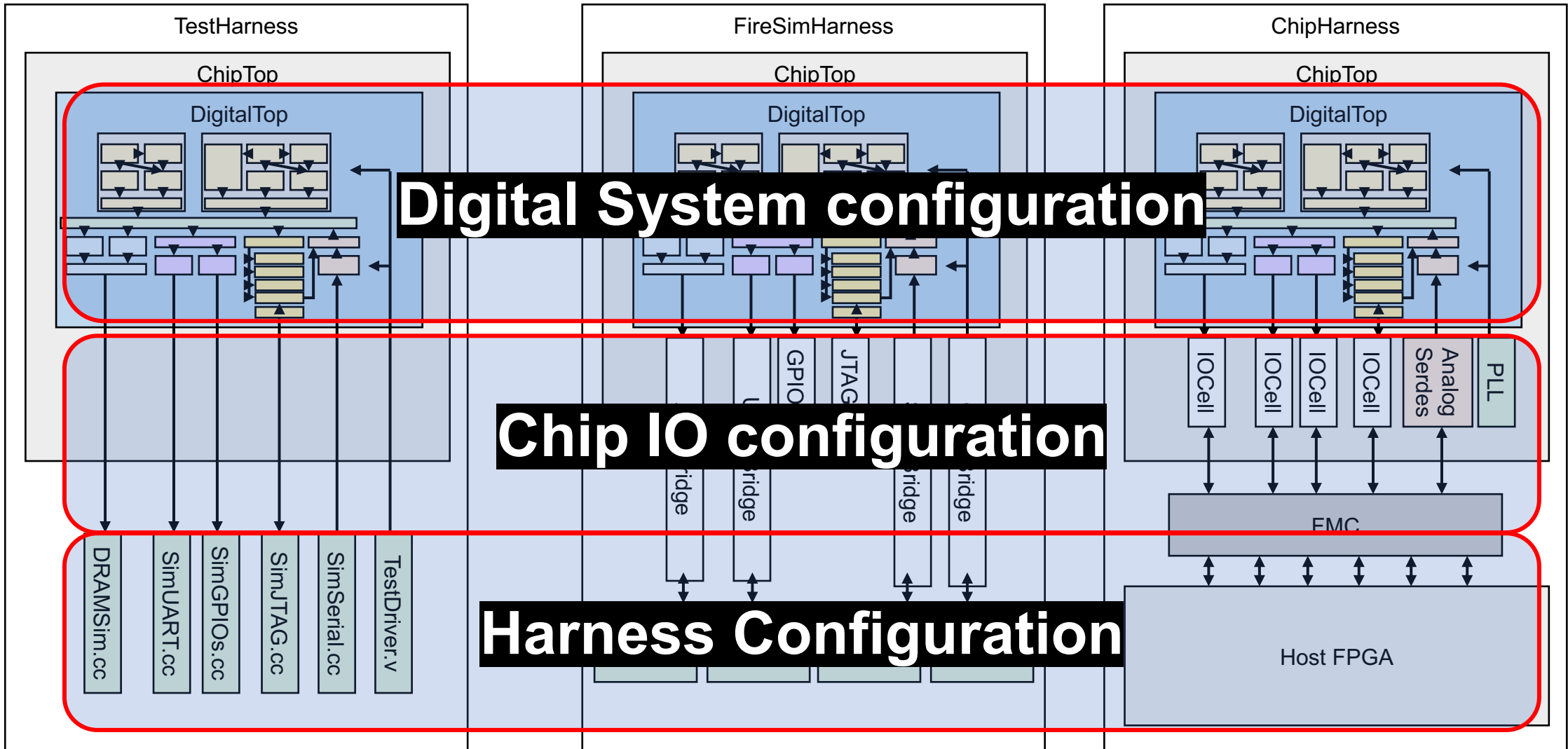
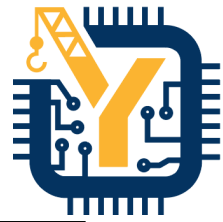

A Complete Config

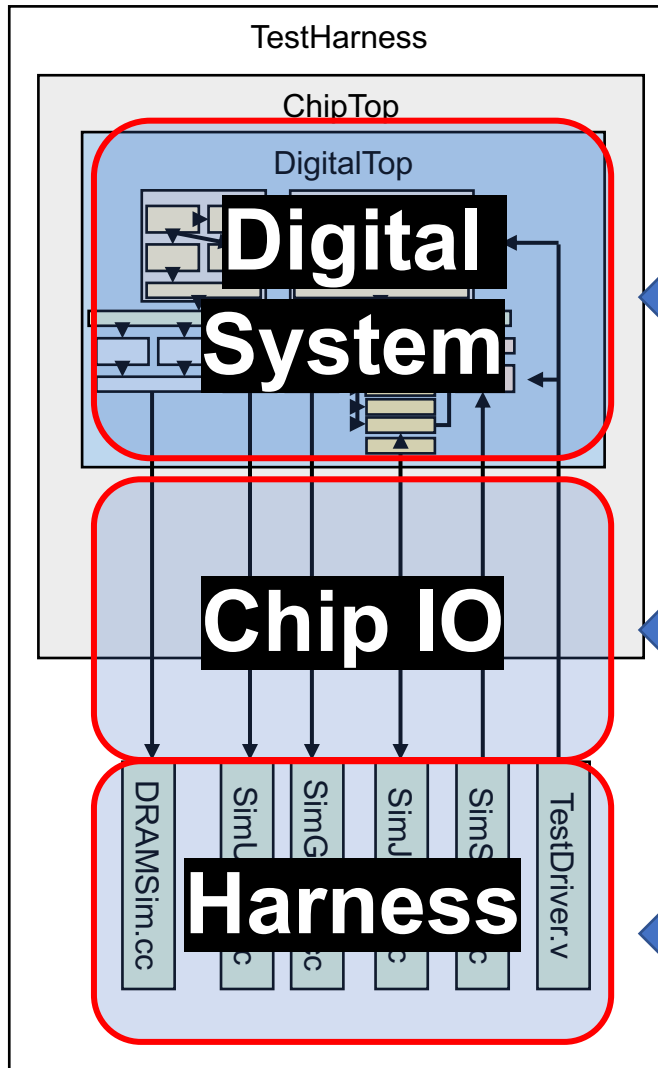
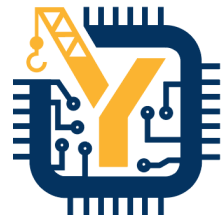

Digital Config

IO Binders

Harness Binders

```
class CustomConfig extends Config(  
  new WithDefaultGemmini ++  
  new WithNRocketCores(1) ++  
  new WithNBoomCores(1) ++  
  new WithBootROM ++  
  new WithUART ++  
  new WithJtagDTM ++  
  new WithGPIOs ++  
  new WithInclusiveCache(512) ++  
  
  new WithIOCellModels ++  
  
  new WithDRAMSim ++  
  new WithSimUART ++  
  new WithSimJTAG ++  
  new WithSimSerial
```

)



Chipyard Organization

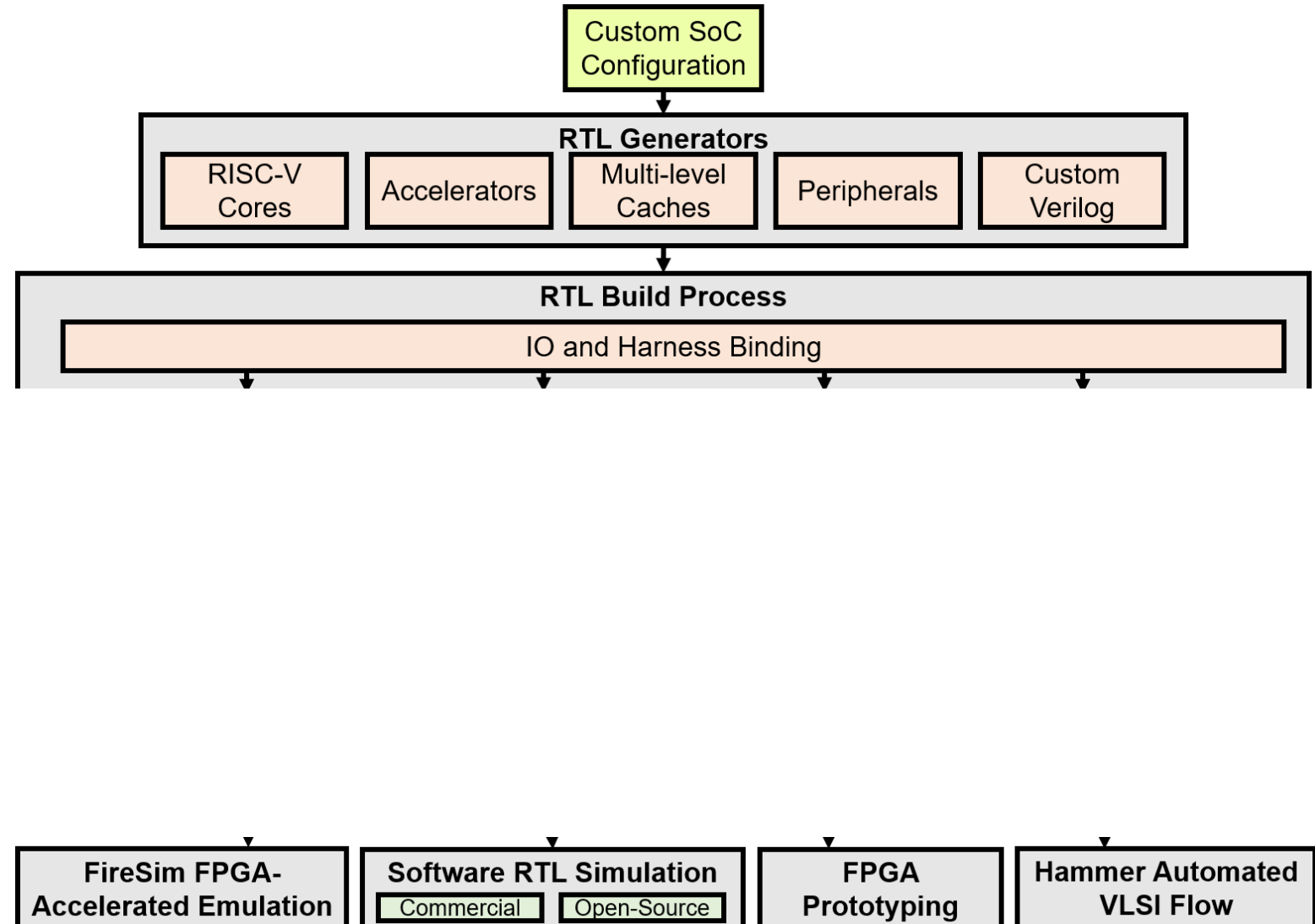
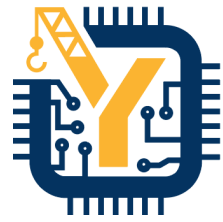

Chipyard Organization

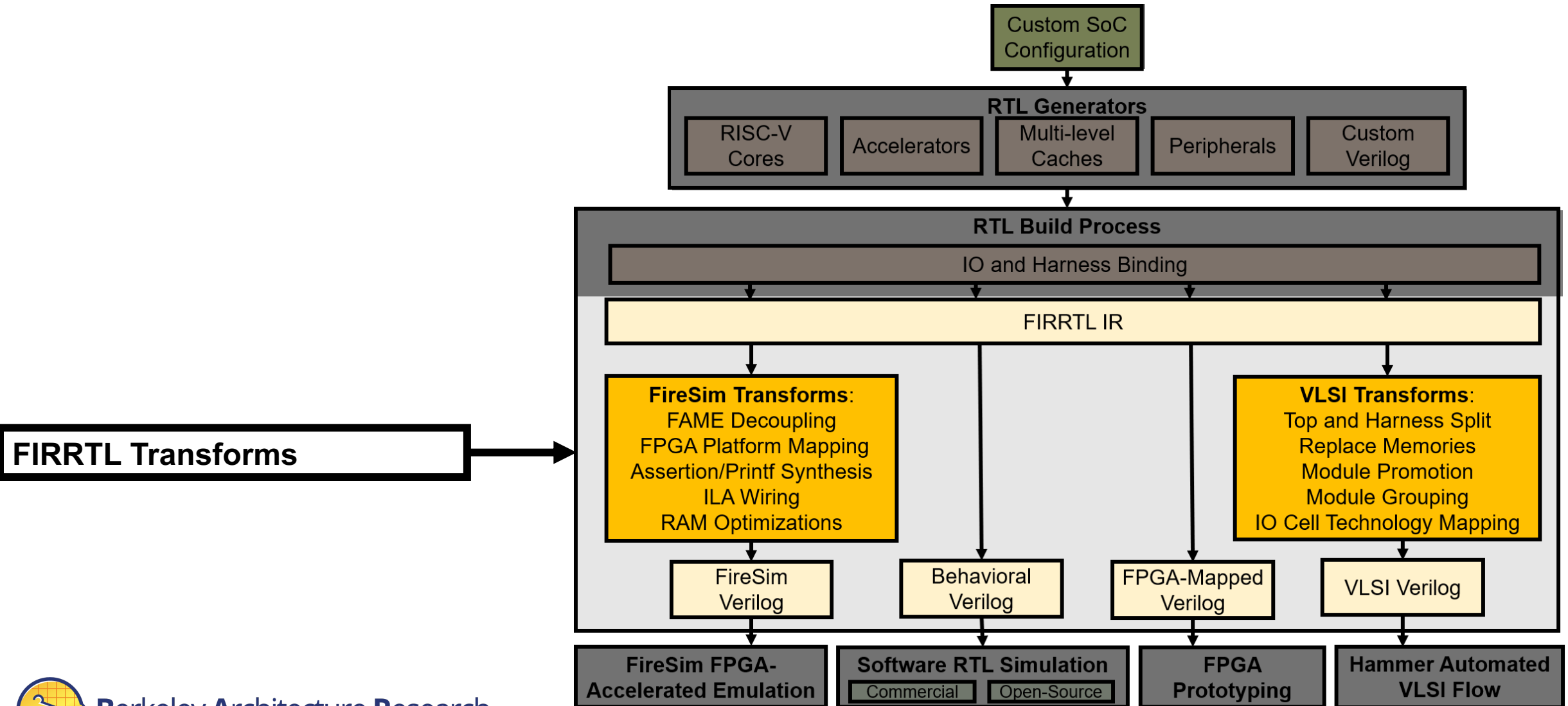
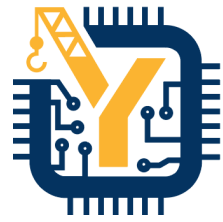

FIRRTL – LLVM for Hardware

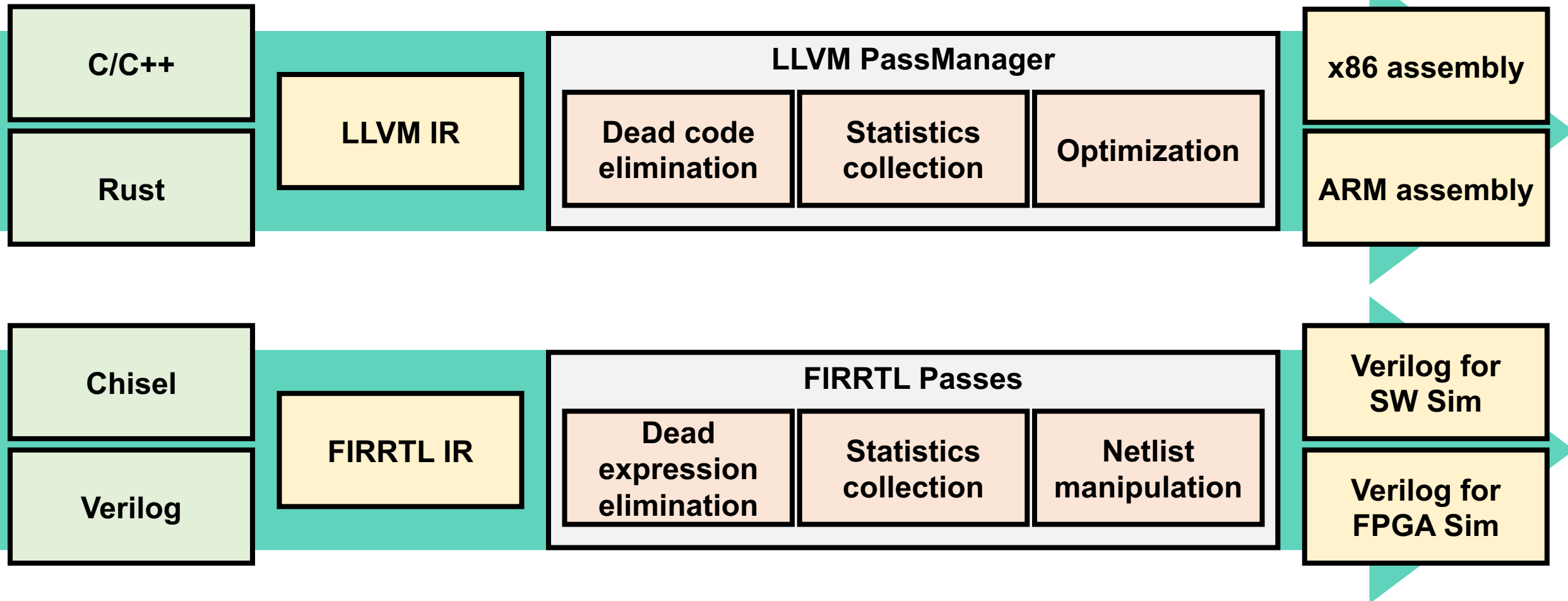
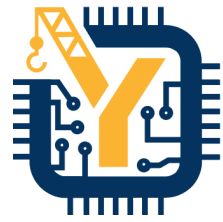

FIRRTL emits **tool-friendly, synthesizable** Verilog



Chipyard Organization

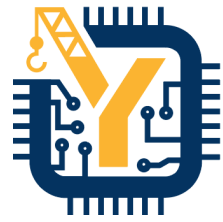

Configs: Describe parameterization of a multi-generator SoC

Generators: Flexible, reusable library of open-source Chisel generators (and Verilog too)

IOBinders/HarnessBinders: Enable configuring IO strategy and Harness features

FIRRTL Passes: Structured mechanism for supporting multiple flows

Target flows: Different use-cases for different types of users

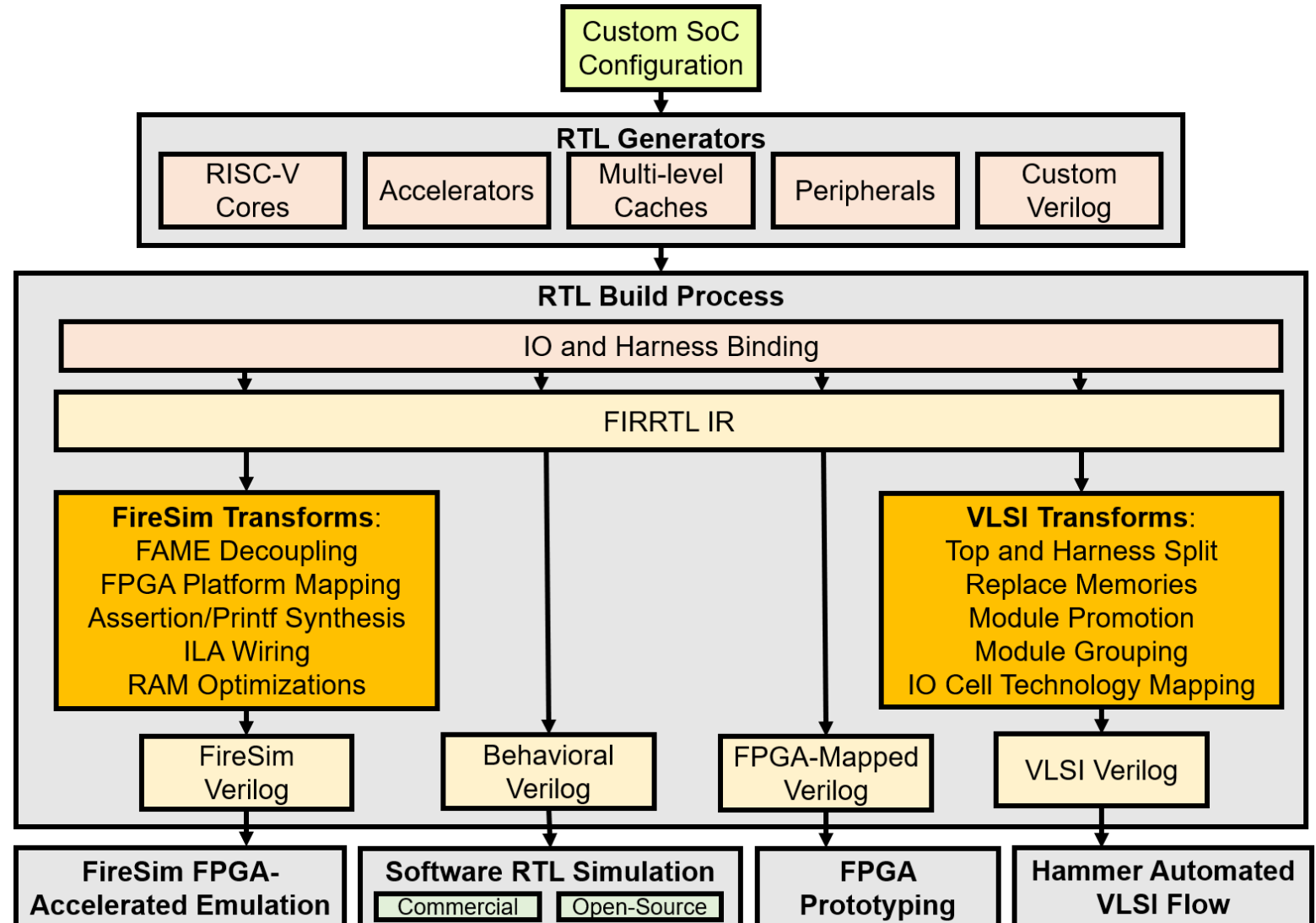

Chipyard Learning Curve

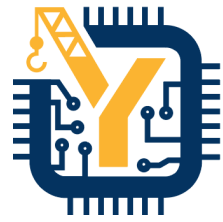

Advanced-level

- Configure custom IO/clocking setups
- Develop custom FireSim extensions
- Integrate and tape-out a complete SoC

Evaluation-level

- Integrate or develop custom hardware IP into Chipyard
- Run FireSim FPGA-accelerated simulations
- Push a design through the Hammer VLSI flow
- Build your own system

Exploratory-level

- Configure a custom SoC from pre-existing components
- Generate RTL, and simulate it in RTL level simulation
- Evaluate existing RISC-V designs

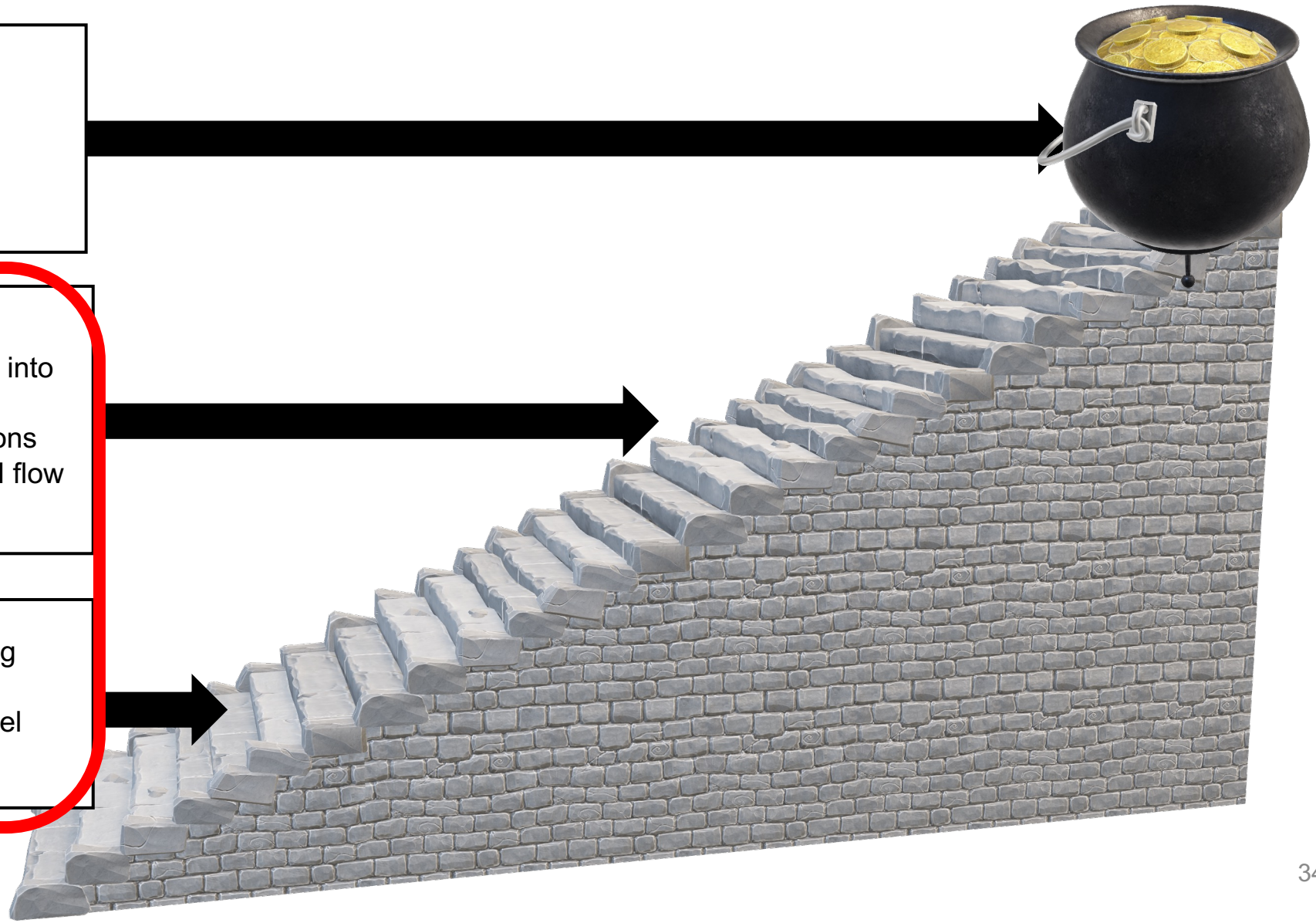

Chipyard is Education Friendly

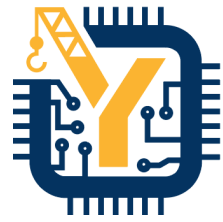

Proven in many Berkeley Architecture courses

- Hardware for Machine Learning
- Undergraduate Computer Architecture
- Graduate Computer Architecture
- Advanced Digital ICs
- Tapeout HW design course

Advantages of common shared HW framework

- Reduced ramp-up time for students
- Students learn framework once, reuse it in later courses
- Enables more advanced course projects (tapeout a chip in 1 semester)

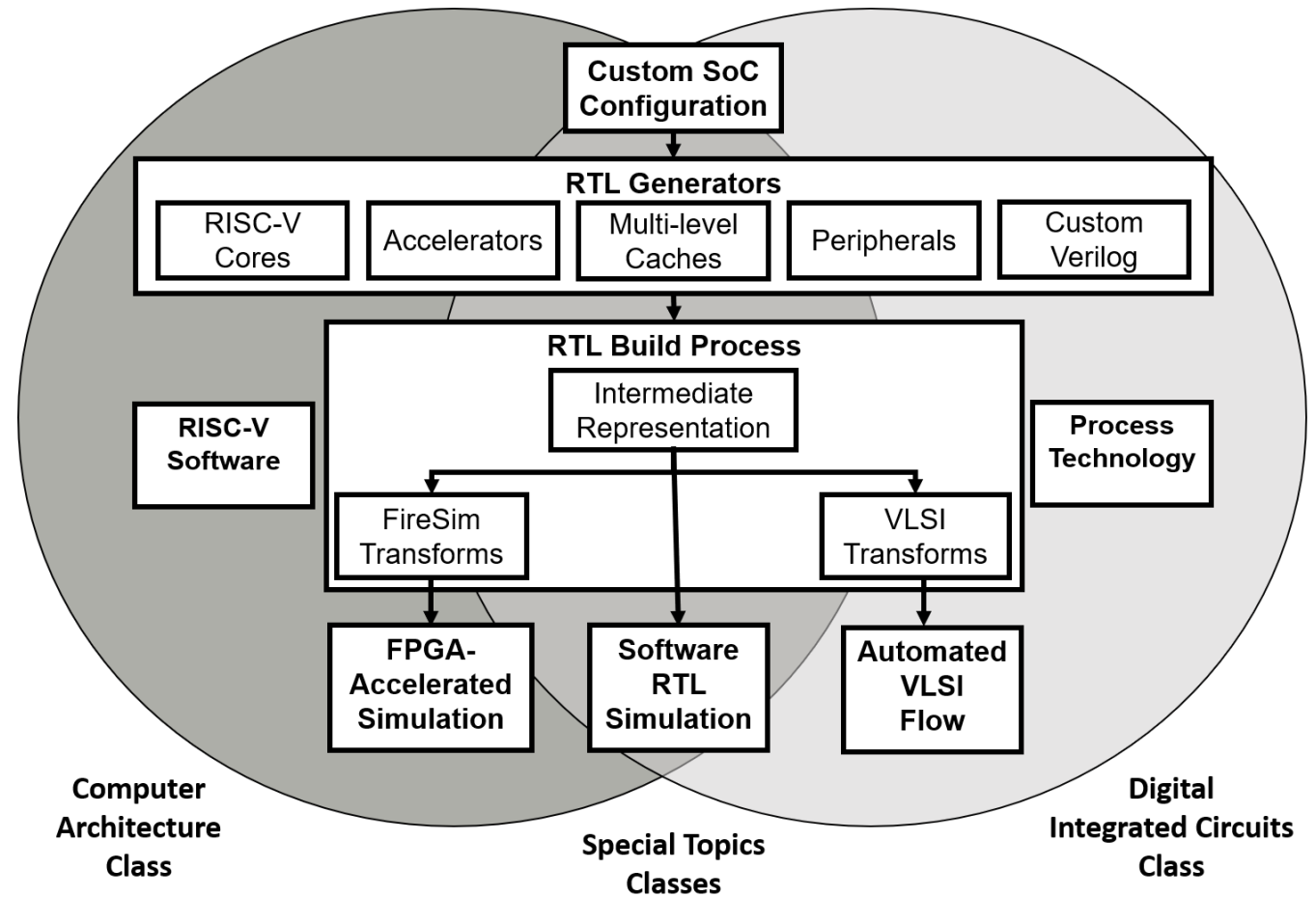

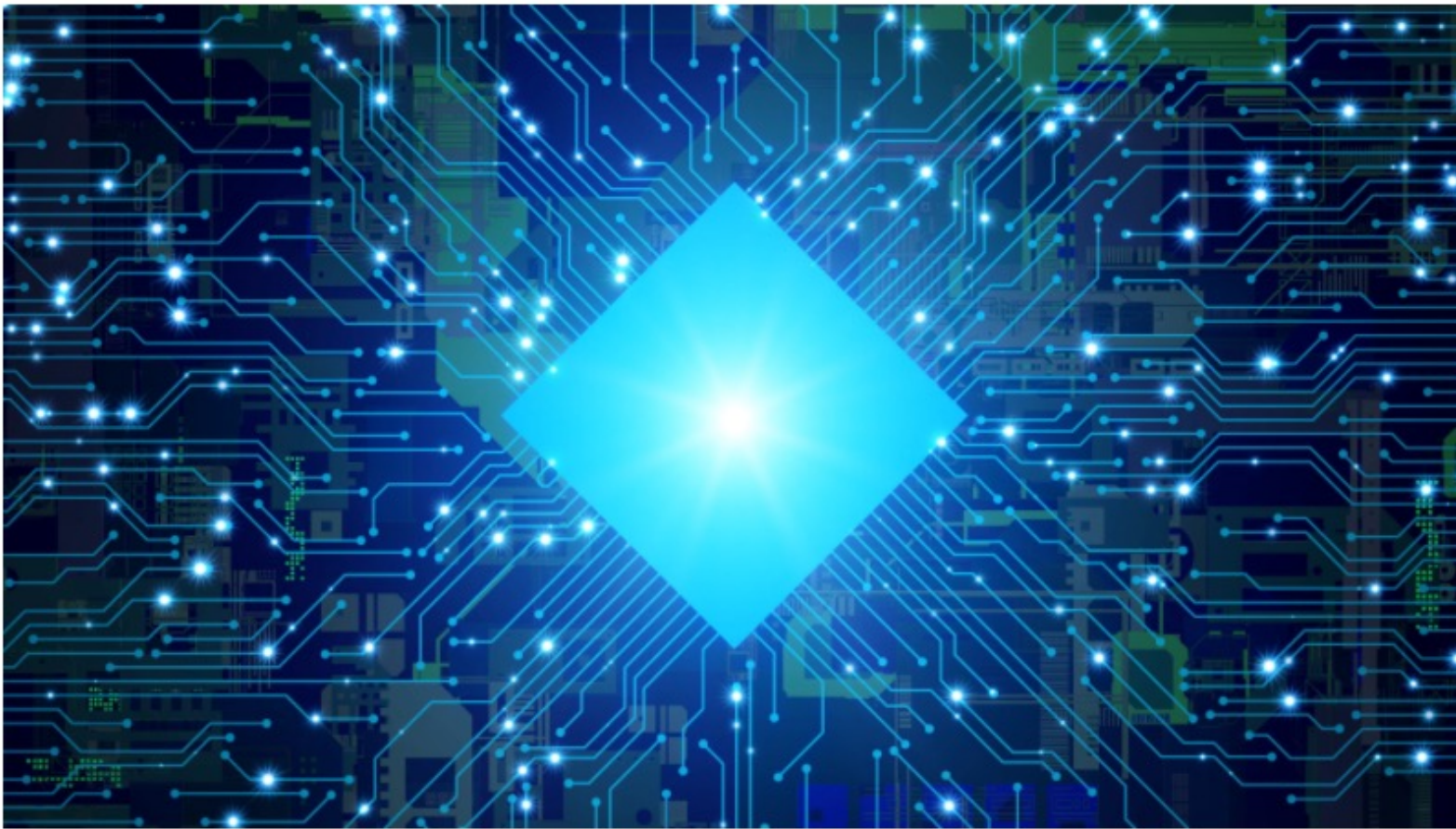
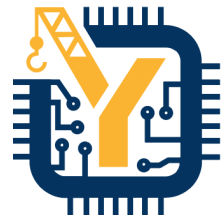

Berkeley Engineering students pull off novel chip design in a single semester. The class shows successful model for expanding entry into field of semiconductor design

Berkeley engineering students pull off novel chip design in a single semester

Class shows successful model for expanding entry into field of semiconductor design



Chipyard for Tapeout Education

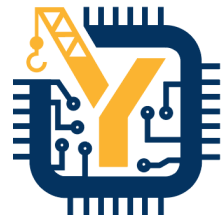

Spring 2021

- 18 mostly masters/PhD
- 1 mm² TSMC 28nm
- 16 weeks from architecture to tapeout
- BLE mixed-signal IoT chip

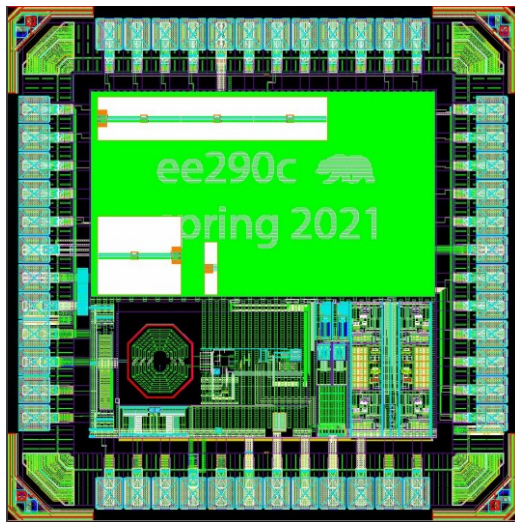

Spring 2022

- ~40 mostly undergrads
- 2 x 4 mm² Intel 16nm
- 16 weeks from architecture to tapeout
- BLE mixed-signal IoT chip
- Heterogeneous RISC-V SoC for sparse-ML and ISP

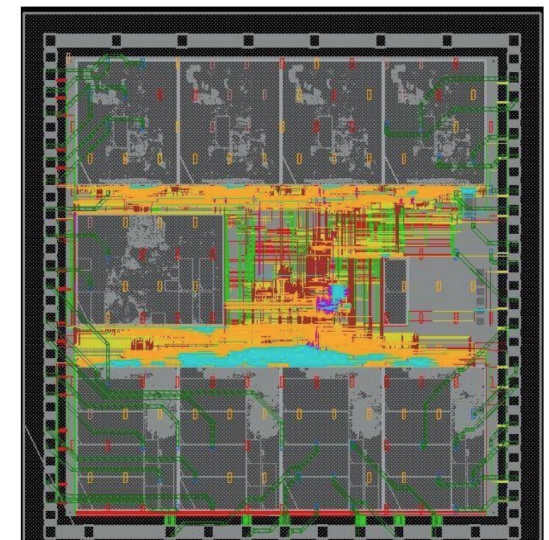
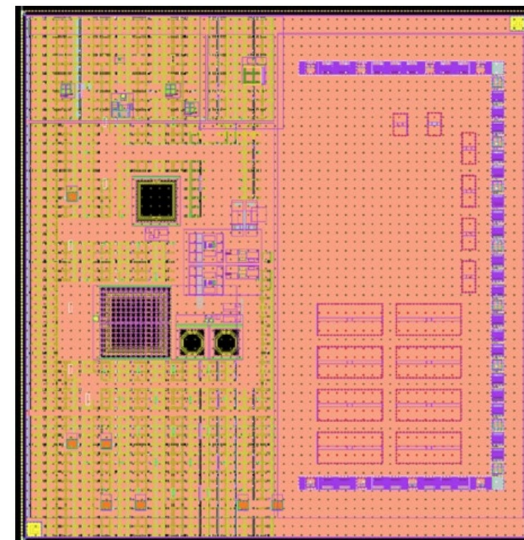

Chipyard is Research-Friendly

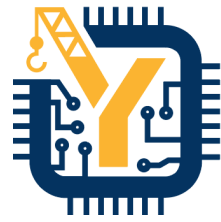

- Add new accelerators for emerging applications
- Modify OS/driver/software
- Perform design-space exploration across many parameters
- Test and evaluate in RTL-simulation, FireSim
- Tapeout using HAMMER VLSI flow



Chipyard is Community-Friendly

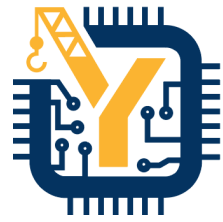

Documentation:

- <https://chipyard.readthedocs.io/en/dev/>
- 133 pages
- Most of today's tutorial content is covered there

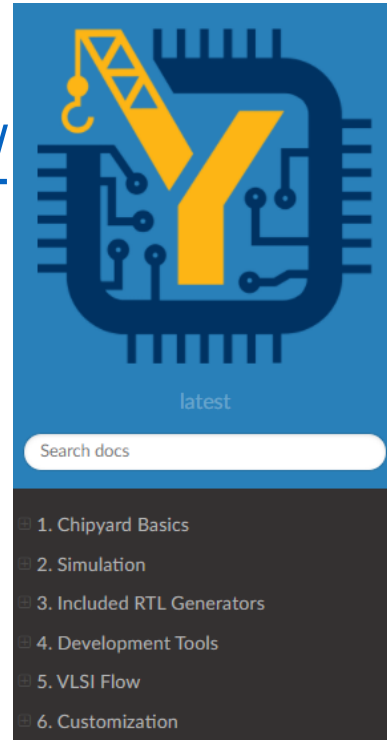

Docs » Welcome to Chipyard's documentation!

[Edit on GitHub](#)

Welcome to Chipyard's documentation!



Chipyard is a framework for designing and evaluating full-system hardware using agile teams. It is composed of a collection of tools and libraries designed to provide an integration between open-source and commercial tools for the development of systems-on-chip.

Important

New to Chipyard? Jump to the [Initial Repository Setup](#) page for setup instructions.

Mailing List:

- google.com/forum/#!forum/chipyard

Open-sourced:

- All code is hosted on GitHub
- Issues, feature-requests, PRs are welcomed

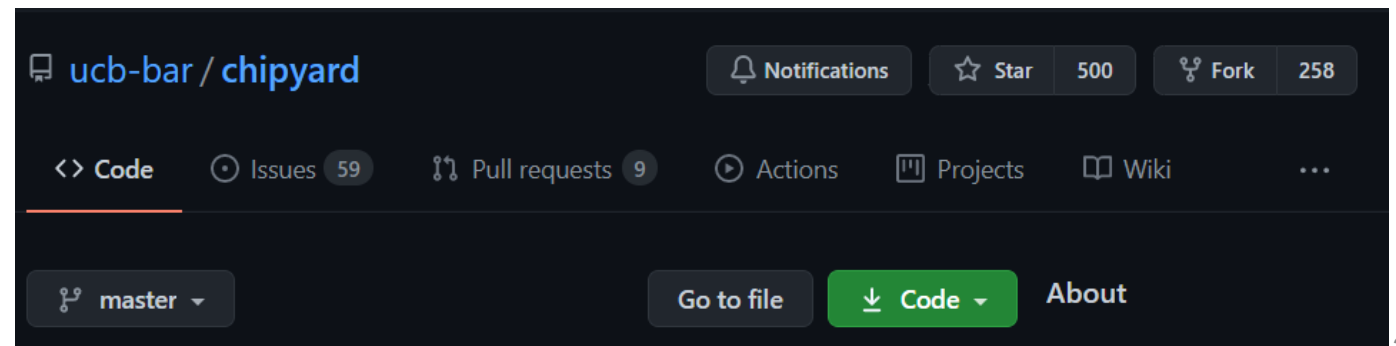

Conclusion

Chipyard: An open, extensible research and design platform for RISC-V SoCs

- Unified framework of parameterized generators
- One-stop-shop for RISC-V SoC design exploration
- Supports variety of flows for multiple use cases
- Open-sourced, community and research-friendly

Questions?



Berkeley Architecture Research



The diagram illustrates the core characteristics of Chipyard: Multi-purpose, Community-friendly, Research-friendly, Beginner-friendly, and Education-friendly. These characteristics converge on the central Chipyard logo, which is a stylized 'Y' shape with a crane hook and circuitry, set within a blue square with rounded corners.

The screenshot shows the documentation website with the following content:

- Header: Docs » Welcome to Chipyard's documentation! Edit on GitHub
- Main heading: Welcome to Chipyard's documentation!
- Logo: CHIPYARD
- Text: Chipyard is a framework for designing and evaluating full-system hardware using agile teams. It is composed of a collection of tools and libraries designed to provide an integration between open-source and commercial tools for the development of systems-on-chip.
- Important section: Important
- Text: New to Chipyard? Jump to the Initial Repository Setup page for setup instructions.