

SIEMENS

SIMATIC

Distributed I/O System Fail-Safe Engineering ET 200S Distributed I/O System

Installation and Operating Manual

Preface

Product Overview

1

Configuring

2

Address Assignment and
Installation

3

Wiring and Fitting Modules

4

Diagnostics

5

General Technical
Specifications

6

Fail-Safe Modules

7

Diagnostic Data of Fail-Safe
Modules

A

Dimension Drawings

B

Accessories and Order
Numbers

C

Response Times

D

Connecting Loads

E



07/2013

A5E00103686-08

Legal information

Warning notice system

This manual contains notices you have to observe in order to ensure your personal safety, as well as to prevent damage to property. The notices referring to your personal safety are highlighted in the manual by a safety alert symbol, notices referring only to property damage have no safety alert symbol. These notices shown below are graded according to the degree of danger.

| |
|--|
|  DANGER |
| indicates that death or severe personal injury will result if proper precautions are not taken. |
|  WARNING |
| indicates that death or severe personal injury may result if proper precautions are not taken. |
|  CAUTION |
| indicates that minor personal injury can result if proper precautions are not taken. |
| NOTICE |
| indicates that property damage can result if proper precautions are not taken. |

If more than one degree of danger is present, the warning notice representing the highest degree of danger will be used. A notice warning of injury to persons with a safety alert symbol may also include a warning relating to property damage.

Qualified Personnel

The product/system described in this documentation may be operated only by **personnel qualified** for the specific task in accordance with the relevant documentation, in particular its warning notices and safety instructions. Qualified personnel are those who, based on their training and experience, are capable of identifying risks and avoiding potential hazards when working with these products/systems.

Proper use of Siemens products

Note the following:

| |
|--|
|  WARNING |
| Siemens products may only be used for the applications described in the catalog and in the relevant technical documentation. If products and components from other manufacturers are used, these must be recommended or approved by Siemens. Proper transport, storage, installation, assembly, commissioning, operation and maintenance are required to ensure that the products operate safely and without any problems. The permissible ambient conditions must be complied with. The information in the relevant documentation must be observed. |

Trademarks

All names identified by ® are registered trademarks of Siemens AG. The remaining trademarks in this publication may be trademarks whose use by third parties for their own purposes could violate the rights of the owner.

Disclaimer of Liability

We have reviewed the contents of this publication to ensure consistency with the hardware and software described. Since variance cannot be precluded entirely, we cannot guarantee full consistency. However, the information in this publication is reviewed regularly and any necessary corrections are included in subsequent editions.

Preface

Purpose of this Manual

The information in this manual is a reference source for operations, function descriptions, and technical specifications of the fail-safe modules of the ET 200S distributed I/O system.

Basic Knowledge Requirements

This manual is a supplement to the *ET 200S Distributed I/O System* manual. Working with this manual requires general knowledge of automation engineering. You also require experience of using the *STEP 7* basic software and the ET 200S distributed I/O system.

Scope of this Manual

| Module | Order Number | Release Number and Higher |
|---|--------------------|---------------------------|
| Power module PM-E F pm DC24V PROFIsafe | 6ES7138-4CF03-0AB0 | 01 |
| Power module PM-E F pp DC24V PROFIsafe | 6ES7138-4CF42-0AB0 | 01 |
| Power module PM-D F DC24V PROFIsafe | 3RK1903-3BA02 | 01 |
| Digital electronic module 4/8 F-DI DC24V PROFIsafe | 6ES7138-4FA05-0AB0 | 01 |
| Digital electronic module 4 F-DI/3 F-DO DC24V PROFIsafe | 6ES7138-4FC01-0AB0 | 01 |
| Digital electronic module 4 F-DO DC24V/2A PROFIsafe | 6ES7138-4FB04-0AB0 | 01 |
| Digital electronic module 1 F-RO DC24V/AC24..230V/5A | 6ES7138-4FR00-0AA0 | 01 |

What's New

Compared with the previous version, this manual includes the following major changes/additions:

- New digital electronic modules 4/8 F-DI DC24V PROFIsafe (6ES7138-4FA05-0AB0) and 4 F-DO DC24V/2A PROFIsafe (6ES7138-4FB04-0AB0) with additional functions:
 - Module embedded diagnostics buffer
 - Firmware update
 - Identification data I&M
 - Reduction of the residual current in the M channel of the new EM 4 F-DO DC24V/2A PROFIsafe to max. 0.5 mA

Approvals

See section "Standards and approvals"

In addition, ET 200S fail-safe modules are certified for use in safety mode up to the following levels:

- Safety Integrity Level SIL3 in accordance with IEC 61508:2000
- Category 4 and Performance Level (PL) e in accordance with ISO 13849-1:2006 or EN ISO 13849-1:2008

CE approval

See section "Standards and approvals"

Certification Mark for Australia (C-Tick Mark)

See section "Standards and approvals"

Standards

See section "Standards and approvals"

Position in the Information Landscape

When working with ET 200S fail-safe modules and depending on your particular application, you will need to consult the additional documentation listed below.

References to this additional documentation are included in the manual where appropriate.

| Documentation | Brief Description of Relevant Contents |
|--|---|
| <i>ET 200S Distributed I/O System</i> operating instructions and manuals | describes all generally applicable topics related to the ET 200S hardware (including configuration, installation and wiring of the ET 200S) and the IM 151 interface module. |
| <i>Safety Engineering in SIMATIC S7</i> system description | <ul style="list-style-type: none"> Provides an overview of the implementation, configuration, and method of operation of S7 Distributed Safety and S7 F/FH fail-safe automation systems Contains a summary of detailed technical information concerning fail-safe engineering in S7-300 and S7-400 Includes monitoring and response time calculations for S7 Distributed Safety and S7 F/FH F-systems |
| For integration in the S7 F/FH F-systems | <p>The <i>S7 F/FH Systems, Configuring and Programming</i> manual describes the tasks that must be performed to create and commission an S7 F/FH F-system.</p> <ul style="list-style-type: none"> The <i>S7-400, M7-400 Programmable Controllers Hardware and Installation</i> manual describes the installation and assembly of S7-400 systems The <i>S7-400 Programmable Controllers, Fault-Tolerant Systems</i> manual describes the CPU 41x-H central modules and the tasks involved in setting up and commissioning an S7-400H fault-tolerant system The <i>CFC for S7 Continuous Function Chart</i> manual/online help provides a description of programming with CFC |
| For integration in the S7 Distributed Safety F-system | <p>The <i>S7 Distributed Safety, Configuring and Programming</i> manual and online help describe the following:</p> <ul style="list-style-type: none"> Configuration of the fail-safe CPU and the fail-safe I/O Programming of the fail-safe CPU in fail-safe FBD or fail-safe LAD <p>Depending on which F-CPU you use, you will need the following documentation:</p> <ul style="list-style-type: none"> The operating instructions <i>S7-300, CPU 31xC and CPU 31x: Configuration</i> describes the configuration, installation, addressing and commissioning of S7-300 systems. The <i>CPU 31xC and CPU 31x, Technical Data</i> manual describes the standard functions of the CPU 315F-2 DP and PN/DP and the CPU 317F-2 DP and PN/DP and the CPU 319F-3 PN/DP. The <i>Automation System S7-400 CPU Specifications</i> manual describes the standard functions of the CPU 41xF-2 and CPU 41xF-3 PN/DP. The <i>ET 200S IM 151-7 CPU Interface Module</i> manual describes the standard functions of the IM 151-7 CPU. The <i>ET 200S IM 151-8 PN/DP CPU Interface Module</i> manual describes the standard functions of the IM 151-8 PN/DP CPU. A separate product information bulletin is available for each applicable F-CPU. The product information bulletins describe only the deviations from the corresponding standard CPUs. |

| Documentation | Brief Description of Relevant Contents |
|-------------------------------|--|
| <i>STEP 7</i> manuals | <ul style="list-style-type: none"> The <i>Configuring Hardware and Communication Connections with STEP 7 V5.x</i> manual describes the operation of the relevant standard tools of <i>STEP 7</i>. The <i>System Software for S7-300/400 System and Standard Functions</i> reference manual describes functions for distributed I/O access and diagnostics. |
| <i>Online Help for STEP 7</i> | <ul style="list-style-type: none"> Describes the operation of <i>STEP 7</i> standard tools Contains information about how to configure and assign parameters for modules and intelligent slaves with <i>HW Config</i> Contains a description of the programming languages FBD and LAD |
| <i>PCS 7</i> manuals | <ul style="list-style-type: none"> Describe how to operate the <i>PCS 7</i> process control system (required when ET 200S with fail-safe modules is integrated in a higher-level control system) |

The entire SIMATIC S7 documentation is available on CD-ROM.

Guide

This manual describes the fail-safe modules of the ET 200S distributed I/O system. It consists of instructive sections and reference sections (technical specifications and appendices).

This manual presents the following basic aspects of fail-safe modules:

- Design and use
- Configuration and parameter assignment
- Addressing, assembly and wiring
- Diagnostic evaluation
- Technical specifications
- Order numbers

Conventions

In this manual, the terms "safety engineering" and "fail-safe engineering" are used synonymously. The same applies to the terms "fail-safe" and "F-."

"*S7 Distributed Safety*" and "*S7 F/FH Systems*" in italics refer to the optional packages for the two F-systems: "S7 Distributed Safety" and "S7 F/FH Systems".

Recycling and Disposal

Due to the low levels of pollutants in the fail-safe modules of the ET 200S, the modules can be recycled. For proper recycling and disposal of your old module (device), consult a certified disposal facility for electronic scrap.

Additional Support

If you have further questions about the use of products presented in this manual, contact your local Siemens representative.

You will find information on whom to contact on the Web (<http://www.siemens.com/automation/partner>).

A guide to the technical documentation for the various SIMATIC products and systems is available on the Web (<http://www.siemens.com/simatic-tech-doku-portal>).

You will find the online catalog and online ordering system on the Web (<http://www.siemens.com/industrymall>).

Training center

We offer relevant courses to help you get started with the SIMATIC automation system. Contact your regional training center or the central training center in 90327 Nuremberg, Germany.

You will find more information on the Internet (<http://www.sitrain.com>).

Functional Safety Services

Via Siemens Functional Safety Services , we support you with a comprehensive package of services: from risk calculation through verification to plant commissioning and modernization. We also offer consultation on the use of failsafe and fault-tolerant SIMATIC S7 automation systems.

You will find more detailed information on the Internet (<http://www.siemens.com/safety-services>).

Please send your queries to: safety-services.industry@siemens.com (<mailto:safety-services.industry@siemens.com>)

Technical Support

To contact Technical Support for all Industry Automation products, use the Web form for the Support Request (<http://www.siemens.de/automation/support-request>).

For additional information about Siemens Technical Support, refer to Internet (<http://www.siemens.de/automation/service>).

Service & Support on the Internet

In addition to our paper documentation, our complete knowledge base is available to you on the Web (<http://www.siemens.com/automation/service&support>).

Here you will find the following information:

- Newsletter providing the latest information on your products
- Exactly the right documentation for your needs, which you can access by performing an online search in Service & Support
- Worldwide forum in which users and experts exchange ideas
- Your local contact for Industry Automation products in our Contact Partners database.
- Information about on-site service, repairs, spare parts, and much more is available under "Repairs, spare parts, and consulting".

Important note for maintaining the operational safety of your system

Note

The operators of systems with safety-related characteristics must adhere to specific operational safety requirements. The supplier is also obliged to comply with special product monitoring stipulations. Siemens publishes a special newsletter to keep you informed about product developments and properties which may be important for plant operation in terms of safety. You need to keep up to date with all information to enable you to make changes to your plant when necessary. To do this, subscribe to the relevant newsletter.

Just visit us on the Web (<http://www.siemens.com/automation/service&support>). Select the link to "Newsletter".

Select the following topic areas:

"Automation Technology":

- S7-300
- S7-400
- Distributed I/Os SIMATIC ET200
- Software for SIMATIC controller

"Safety systems - Safety Integrated":

- Safety Integrated at SIMATIC

Select the check box "Update" to receive information on all innovations or changes.

See also

Standards and Approvals (Page 61)

Note on IT security

Siemens offers IT security mechanisms for its automation and drive product portfolio in order to support the safe operation of the plant/machine. We recommend that you inform yourself regularly on the IT security developments regarding your products. You can find information on this on the Internet (<http://support.automation.siemens.com>).

You can register for a product-specific newsletter here.

For the safe operation of a plant/machine, however, it is also necessary to integrate the automation components into an overall IT security concept for the entire plant/machine, which corresponds to the state-of-the-art IT technology. You can find information on this on the Internet (<http://www.siemens.com/industrialsecurity>).

Products used from other manufacturers should also be taken into account here.

Table of contents

| | | |
|----------|--|-----------|
| | Preface | 3 |
| 1 | Product Overview..... | 15 |
| 1.1 | Introduction | 15 |
| 1.2 | ET 200S fail-safe modules..... | 15 |
| 1.3 | Using fail-safe ET 200S modules..... | 16 |
| 1.4 | Guide for Commissioning of ET 200S with Fail-Safe Modules | 21 |
| 2 | Configuring | 23 |
| 2.1 | Configuration of ET 200S with Fail-Safe Modules | 23 |
| 2.2 | Assigning ET 200S modules..... | 26 |
| 2.3 | Maximum Number of Connectable Modules/Maximum Configuration | 29 |
| 2.4 | Configuration and Parameter Assignment..... | 30 |
| 2.5 | Firmware update | 31 |
| 2.6 | Identification and Maintenance Data (I&M data)..... | 33 |
| 2.6.1 | I&M data for PROFIBUS DP | 33 |
| 2.6.2 | I&M data for PROFINET IO | 37 |
| 3 | Address Assignment and Installation..... | 39 |
| 3.1 | Address assignments in the F-CPU..... | 39 |
| 3.2 | Assignment of the PROFIsafe address | 41 |
| 3.3 | Installing | 44 |
| 4 | Wiring and Fitting Modules..... | 45 |
| 4.1 | Introduction | 45 |
| 4.2 | Safe Functional Extra-Low Voltage (SELV) for Fail-Safe Modules | 45 |
| 4.3 | Wiring fail-safe modules..... | 47 |
| 4.4 | Inserting and Removing Fail-Safe Modules | 48 |
| 4.5 | Requirements for Sensors and Actuators..... | 50 |
| 5 | Diagnostics | 53 |
| 5.1 | Reactions to Faults | 53 |
| 5.2 | Fault Diagnostics..... | 55 |
| 6 | General Technical Specifications | 61 |
| 6.1 | Introduction | 61 |
| 6.2 | Standards and Approvals..... | 61 |
| 6.3 | Electromagnetic Compatibility..... | 66 |

| | | |
|----------|---|-----------|
| 6.4 | Shipping and Storage Conditions | 70 |
| 6.5 | Mechanical and Climatic Environmental Conditions | 70 |
| 6.6 | Specifications for Nominal Line Voltages, Isolation Tests, Protection Class, and Type of Protection | 73 |
| 7 | Fail-Safe Modules | 75 |
| 7.1 | Introduction..... | 75 |
| 7.2 | PM-E F pm DC24V PROFIsafe Power Module | 77 |
| 7.2.1 | Properties of the PM-E F pm DC24V PROFIsafe Power Module..... | 77 |
| 7.2.2 | Terminal assignment of the PM-E F pm DC24V PROFIsafe..... | 81 |
| 7.2.3 | Wiring of the PM-E F pm DC24V PROFIsafe | 84 |
| 7.2.4 | Parameters of the PM-E F pm 24 VDC PROFIsafe..... | 89 |
| 7.2.5 | Diagnostic Functions of the PM-E F pm DC24V PROFIsafe..... | 91 |
| 7.2.6 | Technical Specifications of PM-E F pm DC24V PROFIsafe..... | 93 |
| 7.3 | PM-E F pp DC24V PROFIsafe power module..... | 98 |
| 7.3.1 | Properties of the PM-E F pp DC24V PROFIsafe Power Module..... | 98 |
| 7.3.2 | Terminal assignment of the PM-E F pp DC24V PROFIsafe..... | 101 |
| 7.3.3 | Wiring of the PM-E F pp DC24V PROFIsafe | 104 |
| 7.3.4 | Parameters of the PM-E F pp DC24V PROFIsafe..... | 106 |
| 7.3.5 | Diagnostic functions of the PM-E F pp DC24V PROFIsafe..... | 107 |
| 7.3.6 | Technical Specifications for PM-E F pp DC24V PROFIsafe | 109 |
| 7.4 | PM-D F DC24V PROFIsafe Power Module | 113 |
| 7.4.1 | Properties of the PM-D F DC24V PROFIsafe Power Module..... | 113 |
| 7.4.2 | Terminal Assignment of the PM-D F DC24V PROFIsafe | 115 |
| 7.4.3 | Wiring of the PM-D F DC24V PROFIsafe | 117 |
| 7.4.4 | Parameters of the PM-D F DC24V PROFIsafe..... | 117 |
| 7.4.5 | Diagnostic Functions of PM-D F DC24V PROFIsafe..... | 118 |
| 7.4.6 | Technical Specifications of the PM-D F DC24V PROFIsafe | 120 |
| 7.5 | 4/8 F-DI DC24V PROFIsafe Digital Electronic Module..... | 122 |
| 7.5.1 | Properties of the 4/8 F-DI DC24V PROFIsafe Digital Electronic Module | 122 |
| 7.5.2 | Terminal Assignment of the EM 4/8 F-DI DC24V PROFIsafe | 123 |
| 7.5.3 | Wiring of the EM 4/8 F-DI DC24V PROFIsafe | 125 |
| 7.5.4 | Parameters of the EM 4/8 F-DI DC24V PROFIsafe | 126 |
| 7.5.5 | Applications for the 4/8 F-DI DC24V PROFIsafe Electronic Module | 131 |
| 7.5.6 | Application 1: SIL2/Category 3/PLd safety mode | 133 |
| 7.5.7 | Application 2: Safety mode SIL3/Category 3/PLe..... | 135 |
| 7.5.8 | Application 3: Safety mode SIL3/Category 4/PLe..... | 144 |
| 7.5.9 | Diagnostic functions of EM 4/8 F-DI DC24V PROFIsafe..... | 149 |
| 7.5.10 | Technical Specifications of the EM 4/8 F-DI DC24V PROFIsafe | 153 |
| 7.6 | EM 4 F-DI/3 F-DO DC24V PROFIsafe digital electronic module..... | 157 |
| 7.6.1 | Properties of the 4 F-DI/3 F-DO DC24V PROFIsafe Digital Electronic Module | 157 |
| 7.6.2 | Terminal assignment of the EM 4 F-DI/3 F-DO DC24V PROFIsafe..... | 160 |
| 7.6.3 | Wiring of the EM 4 F-DI/3 F-DO DC24V PROFIsafe | 162 |
| 7.6.4 | EM 4 F-DI/3 F-DO DC24V PROFIsafe parameters | 163 |
| 7.6.5 | Input applications of EM 4 F-DI/3 F-DO DC24V PROFIsafe | 167 |
| 7.6.6 | Output applications of EM 4 F-DI/3 F-DO DC24V PROFIsafe | 177 |
| 7.6.7 | Diagnostic functions of EM 4 F-DI/3 F-DO DC24V PROFIsafe..... | 179 |
| 7.6.8 | Technical specifications of the EM 4 F-DI/3 F-DO DC24V PROFIsafe | 182 |

| | | |
|----------|---|------------|
| 7.7 | 4 F-DO DC24V/2A PROFIsafe digital electronic module | 186 |
| 7.7.1 | Properties of the 4 F-DO DC24V/2A PROFIsafe Digital Electronic Module | 186 |
| 7.7.2 | Terminal assignment of the EM 4 F-DO DC24V/2A PROFIsafe | 189 |
| 7.7.3 | Wiring diagram of the EM 4 F-DO DC24V/2A PROFIsafe | 191 |
| 7.7.4 | Parameters of the EM 4 F-DO DC24V/2A PROFIsafe | 195 |
| 7.7.5 | Diagnostic Functions of the EM 4 F-DO DC24V/2 A PROFIsafe | 196 |
| 7.7.6 | Technical Specifications of the EM 4 F-DO DC24V/2A PROFIsafe | 200 |
| 7.8 | 1 F-RO DC24V/AC24..230V/5A Digital Electronic Module | 203 |
| 7.8.1 | Properties of the EM 1 F-RO DC24V/AC24..230V/5A | 203 |
| 7.8.2 | Terminal assignment of EM 1F-RO DC24V/AC24..230V/5A | 205 |
| 7.8.3 | Wiring of EM 1 F-RO DC24V/AC24..230V/5A | 208 |
| 7.8.4 | Diagnostic functions of EM 1 F-RO DC24V/AC24..230V/5A | 212 |
| 7.8.5 | Technical specifications of the EM 1 F-RO DC24V/AC24..230V/5A | 212 |
| A | Diagnostic Data of Fail-Safe Modules..... | 217 |
| A.1 | Introduction | 217 |
| A.2 | Structure and Content of Diagnostic Data | 217 |
| B | Dimension Drawings | 227 |
| C | Accessories and Order Numbers..... | 229 |
| D | Response Times | 231 |
| E | Connecting Loads | 237 |
| E.1 | Connecting capacitive loads | 237 |
| E.2 | Connecting inductive loads | 239 |
| | Glossary | 241 |
| | Index..... | 251 |

Product Overview

1.1 Introduction

Overview

This chapter provides information about the following topics:

- ET 200S distributed I/O system with fail-safe modules and its place in SIMATIC S7 fail-safe automation systems
- Components comprising the ET 200S distributed I/O system with fail-safe modules
- The steps you must perform, ranging from selection of the F-modules to commissioning of ET 200S on PROFIBUS DP/PROFINET IO

1.2 ET 200S fail-safe modules

Fail-safe automation system

Fail-safe automation systems (F-systems) are used in systems with higher-level safety requirements. F-systems are used to control processes having a safe state immediately after shutdown. In other words, F-systems control processes in which an immediate shutdown does not endanger humans or the environment.

ET 200S Distributed I/O System

The ET 200S distributed I/O system is a DP slave/IO device on PROFIBUS DP/PROFINET IO that can contain fail-safe modules in addition to ET 200S standard modules.

You can use copper cables, fiber-optic cables or WLAN (*S7 Distributed Safety* as of V5.4) to assemble the PROFIBUS DP/PROFINET IO lines.

Fail-safe modules

The major difference between fail-safe modules and standard ET 200S modules is that fail-safe modules have a two-channel internal design. Both integrated processors monitor each other, automatically test the I/O circuits, and set the F-module to safe state in the event of a fault. The F-CPU communicates with the fail-safe module using the PROFIsafe safety-related bus profile.

Fail-safe power modules are used to supply load voltage to the potential group and to safely shut down the load voltage for standard output modules.

Fail-safe digital input modules record the signal states of safety-related sensors and send corresponding safety message frames to the F-CPU.

Fail-safe digital output modules are suitable for shutdown procedures with short-circuit and cross-circuit protection up to the actuator.

1.3 Using fail-safe ET 200S modules

Possible Uses of ET 200S with Fail-Safe Modules

The use of ET 200S with fail-safe modules enables conventional safety engineering designs to be replaced with PROFIBUS DP/PROFINET IO components. This includes the replacement of switching devices for emergency STOP, protective door monitors, two-hand operation, etc.

Use in F-systems

To use fail-safe ET 200S modules, you need

- For the order numbers listed in the "Preface":
F-Configuration Pack as of version V5.5 SP5, except
- For digital electronic modules 4/8 F-DI DC24V PROFIsafe (6ES7138-4FA05-0AB0) and 4 F-DO DC24V/2A PROFIsafe (6ES7138-4FB04-0AB0):
F-Configuration Pack as of version V5.5 SP9 Update 1
 - The *F Configuration Pack* can be obtained on the Internet (<http://support.automation.siemens.com/WW/view/en/15208817>).

Fail-safe ET 200S modules can be used:

- In the S7 Distributed Safety F-system with the *S7 Distributed Safety* optional package V5.2 or higher
- In the S7 F/FH Systems with the *S7 F System* optional package version V5.2 SP3 or higher

- To connect fail-safe ET 200S modules to PROFIBUS DP with Distributed Safety or S7 F/FH systems, you need:
 - ET 200S fail-safe modules
 - F-CPU
 - *STEP 7* V5.3 SP3 or higher
 - IM151-1 DP HIGH FEATURE interface module
 - *S7 Distributed Safety* as of V5.2
 - *S7 F Systems* V5.2 SP3 or higher

You should also observe the readme file for the *F Configuration Pack* and the operating instructions for your F system.

- To connect ET 200S fail-safe modules to PROFINET IO with Distributed Safety, you need:
 - ET 200S fail-safe modules
 - F-CPU
 - *STEP 7* V5.3 SP3 or higher
 - IM 151-3 PN HIGH FEATURE interface module
 - *S7 Distributed Safety* as of V5.4

You should also observe the readme file for the *F Configuration Pack* and the operating instructions for your F system.

- For the central use of the fail-safe ET 200S modules with distributed safety, you require an IM 151-7 F-CPU or IM 151-8 PN/DP F-CPU.

When using fail-safe ET 200S I/O modules in F-systems, the information contained in the following manuals applies:

- *ET 200S distributed I/O system*
- *Safety Engineering in SIMATIC S7*
- *S7 Distributed Safety, Configuring and Programming* or *S7 F/FH Systems, Configuring and Programming*

F-System with ET 200S

The following figure presents an example configuration for an S7 Distributed Safety F-system including an ET 200S on PROFIBUS DP/PROFINET IO.

The fail-safe DP master/IO controller exchanges safety-related and non-safety-related data with the fail-safe and standard ET 200S modules, etc.

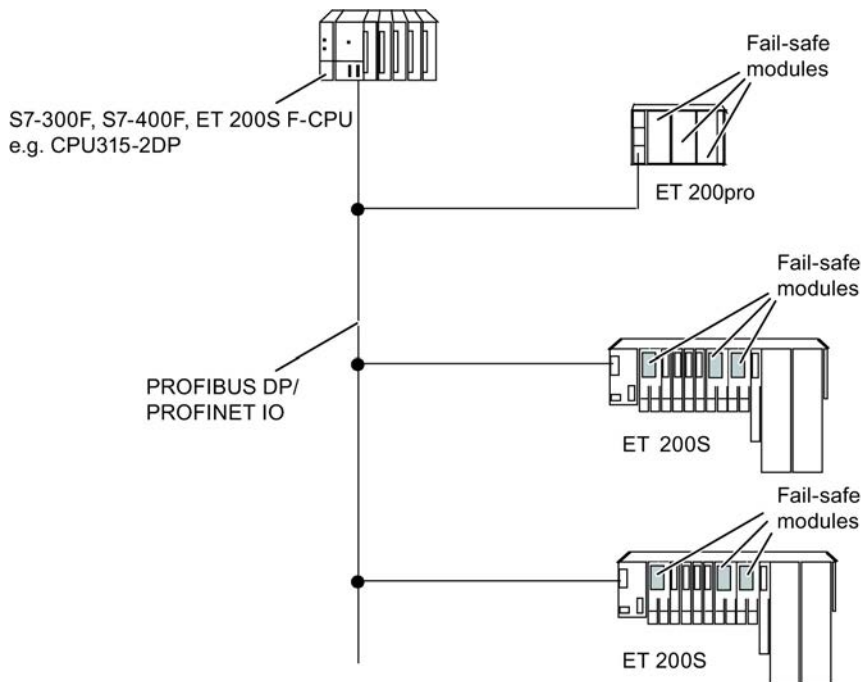

Figure 1-1 S7 Distributed Safety Fail-Safe Automation System (Example Configuration)

Availability of Fail-Safe Electronic Modules

The following fail-safe electronic modules are available for ET 200S:

- Power module PM-E F pm DC24V PROFIsafe; switching to P/M potential, with 2 additional, fail-safe digital outputs
- Power module PM-E F pp DC24V PROFIsafe; switching to P/P potential
- Power module PM-D F DC24V PROFIsafe; switching to P/P potential
- Digital electronic module 4/8 F-DI DC24V PROFIsafe
- Digital electronic module 4 F-DI/3 F-DO DC24V PROFIsafe
- Digital electronic module 4 F-DO DC24V/2A PROFIsafe; switching to P/M potential
- Digital electronic module 1 F-RO DC24V/AC24..230V/5A

The PM-D F DC24V PROFIsafe is used for selective shutdowns of fail-safe motor starters via six fail-safe shutdown groups.

A range of terminal modules is available for fail-safe power and electronic modules. You will find a detailed list in this manual.

Using Interface Modules in ET 200S with Fail-Safe Modules

Depending on the F system, select the interface module for ET 200S as follows:

Table 1- 1 Using Interface Modules in ET 200S with Fail-Safe Modules

| Interface module | As of order number | Can be used in ET 200S with optional package | As of version |
|--|--------------------|--|---------------|
| IM 151-1 HIGH FEATURE for PROFIBUS DP interface | 6ES7151-1BA01-0AB0 | <i>S7 Distributed Safety</i> | V5.2 |
| | | <i>S7 F Systems</i> | V5.2 |
| IM 151-7 F-CPU for PROFIBUS DP interface | 6ES7151-7FA01-0AB0 | <i>S7 Distributed Safety</i> | V5.2 |
| IM 151-8 DP/PN F-CPU for PROFINET IO interface | 6ES7151-8FB00-0AB0 | <i>S7 Distributed Safety</i> | V5.4 |
| IM 151-3 PN HIGH FEATURE for PROFINET IO interface | 6ES7151-3BA20-0AB0 | <i>S7 Distributed Safety</i> | V5.4 |
| | 6ES7151-3BB21-0AB0 | <i>S7 F Systems</i> | V6.1 SP1 |

The IM 151-1 HIGH FEATURE and the IM 151-3 PN HIGH FEATURE are described in the respective manuals *ET 200S Distributed I/O System*. The IM 151-7 F-CPU and IM 151-8 PN/DP F-CPU are described in a separate product information.

Restrictions with EM 4 F-DI/3 F-DO DC24V PROFIsafe

The EM 4 F-DI/3 F-DO DC24V PROFIsafe only supports operation in distributed systems with the following interface modules:

- As of order number 6ES7151-1BA01-0AB0, as of V2.0.0
- As of order number 6ES7151-3BA20-0AB0, as of V3.0.0
- As of order number 6ES7151-3BB21-0AB0, as of V3.0.0

The EM 4 F-DI/3 F-DO DC24V PROFIsafe can be used centrally with IM 151-7 F-CPU 6ES7151-7FA20-0AB0 V2.6 or higher or IM 151-8 F-CPU 6ES7151-8FB00-0AB0.

Restrictions with PM E F pp DC24V PROFIsafe

The use of the fail-safe power module PM E F pp DC24V PROFIsafe with IM151-1 HIGH FEATURE or IM151 7 F-CPU interface modules is only possible:

- As of order number 6ES7151-1BA01-0AB0, as of firmware version V1.1.1 or
- As of order number 6ES7151-7FA01-0AB0, as of firmware version V2.1.4

Use in Safety Mode Only

Fail-safe modules can only be used in safety mode. They cannot be used in standard mode.

Achievable Safety Classes

Fail-safe modules are equipped with integrated safety functions for safety mode.

The following safety classes can be achieved in safety mode by assigning appropriate parameters to the safety functions in *STEP 7* with the *S7 Distributed Safety* or *S7 F Systems* optional package, by combining certain standard and F-modules and by arranging the wiring of the sensors and actuators in a specific way:

Table 1- 2 Achievable Safety Classes in Safety Mode

| in accordance with IEC 61508:2000 | in accordance with ISO 13849-1:2006 or EN ISO 13849-1:2008 |
|-----------------------------------|--|
| SIL2 | Cat.3/PLd |
| SIL3 | Cat.3/PLe |
| SIL3 | Cat.4/PLe |

See also

Configuration of ET 200S with Fail-Safe Modules (Page 23)

Requirements for Sensors and Actuators (Page 50)

Input applications of EM 4 F-DI/3 F-DO DC24V PROFIsafe (Page 167)

1.4 Guide for Commissioning of ET 200S with Fail-Safe Modules

Introduction

The following table lists all the important steps required for commissioning ET 200S distributed I/O systems with fail-safe modules as DP slaves/IO devices on PROFIBUS DP/PROFINET IO.

Steps from Selecting the F-Modules to Commissioning the ET 200S

Table 1- 3 Steps from Selecting the F-Modules to Commissioning the ET 200S

| Step | Procedure | See ... |
|------|---|---|
| 1. | Select F-modules for ET 200S configuration | "Configuring" chapter |
| 2. | Configure and assign parameters to F-modules in <i>STEP 7</i> | "Configuration and Parameter Assignment" and "Fail-Safe Modules" chapters |
| 3. | Set PROFIsafe addresses on F-modules | "Address Assignment and Installation" chapter |
| 4. | Install ET 200S | "Address Assignment and Installation" chapter |
| 5. | Wire the ET 200S | "Wiring and Fitting Modules" chapter |
| 6. | Commission ET 200S on PROFIBUS DP/PROFINET IO | <i>ET 200S Distributed I/O System</i> operating instructions |
| 7. | Run diagnostics on ET 200S if commissioning failed | "Diagnostics" chapter, "Fail-Safe Modules" chapter and <i>ET 200S Distributed I/O System</i> operating instructions |

Note

You must configure and assign parameters to the F-modules in *STEP 7* before you start commissioning.

Reason: *STEP 7* automatically assigns the PROFIsafe addresses to the F-modules. You must set these PROFIsafe addresses by means of switches on all F-modules prior to their installation.

Configuring

2.1 Configuration of ET 200S with Fail-Safe Modules

Introduction

The ET 200S distributed I/O systems support configurations with standard and fail-safe modules. This section presents an example configuration.

Configuration example of ET 200S with Fail-Safe Modules

In the following figure you will find a configuration example using standard and fail-safe modules in an ET 200S. You *can* divide and install the modules in fail-safe and standard potential groups. A new potential group always begins with a power module.

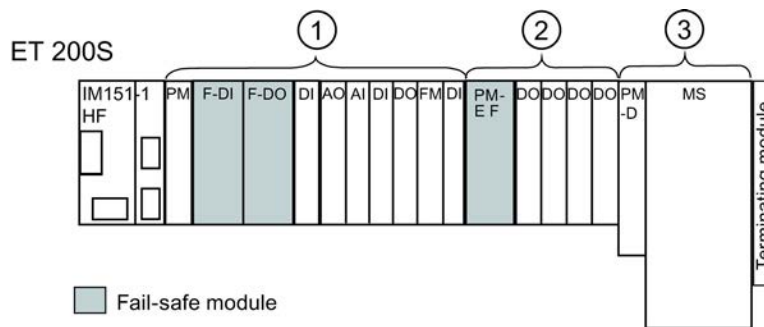

- ① Fail-safe and standard potential group mixed (SIL3/Cat.4/PLe possible for fail-safe modules if the standard modules used are suitably qualified. Pay heed to the following warning and the provided hyperlink.)
- ② Fail-safe potential group (SIL3/Cat.4/PLe for the two fail-safe digital outputs of the PM-E F pm DC24V PROFIsafe if the possible standard modules used are suitably qualified. Pay heed to the following warning and the provided hyperlink.)
- ③ Standard potential group

Figure 2-1 ET 200S Configuration Example with Fail-Safe Modules

 **WARNING**

If the implemented standard module has electrical isolation of ≥ 60 VAC / 75 VDC and test voltage of 500 VDC, it is possible to mix F-DI-/F-DO modules and standard DI-/DO-/FM modules within one potential group as of the following MLFBs for the SIL3/Category 4/PLe:

- 6ES7138-4CF03-0AB0
- 6ES7138-4CF42-0AB0
- 3RK1903-3BA02
- 6ES7138-4FA04-0AB0
- 6ES7138-4FC01-0AB0
- 6ES7138-4FB03-0AB0
- 6ES7 138-4FR00-0AA0

For the predecessor modules, you can achieve SIL2/Category 3/PLd with a mix of F-DI-/F-DO modules and standard DI-DO modules.

Configuration Rules for Fail-Safe Potential Groups

The "Assigning Power Modules to Electronic Modules/Motor Starters and Safety Class" table lists all the fail-safe and standard power modules and electronic modules you can implement in a potential group.

Configuration with Fail-Safe Motor Starters and Frequency Converters

Use a PM-D F DC24V PROFIsafe for the selective shutdown of:

- Fail-safe motor starters (F-MS) F-DS1e-x, F-RS1e-x
- SINAMICS fail-safe frequency converters (F-FU) with ICU24(F)
- Fail-safe F-CM connection multipliers
- PM-D F X1 fail-safe power/expansion modules.

The PM-D F DC24V PROFIsafe cannot supply other motor starters (such as DS1-x/RS1-x, DS1e-x/RS1e-x, DSS1e-x)!

The fail-safe motor starters can be expanded:

- Up to safety class SIL3/Category 4/PLe with the Brake Control xB1, xB2 expansion modules
- Up to safety class SIL2/Category 3/PLd with the Brake Control xB3, xB4 expansion modules

Example of a Configuration with Fail-safe Motor Starters

The figure below shows an example of an ET 200S configuration with two fail-safe potential groups. The first potential group contains fail-safe motor starters and a connection multiplier. This configuration achieves safety class SIL3/Category 4/PLe.

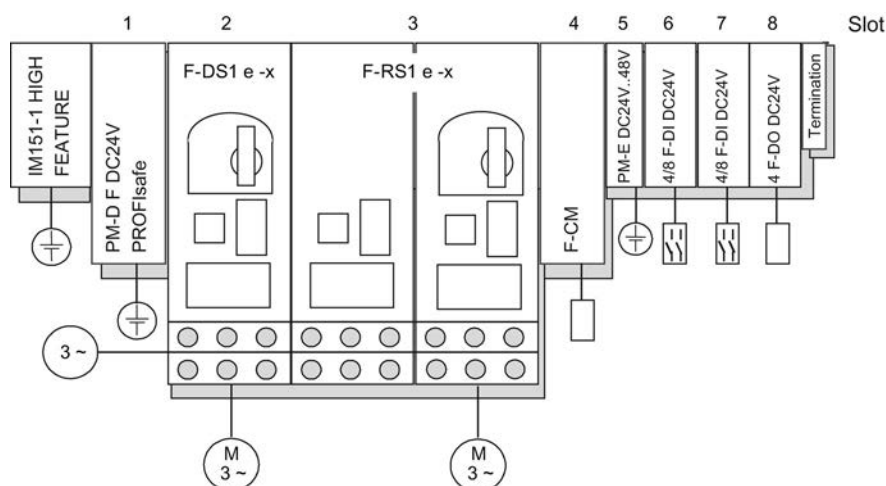

Figure 2-2 Configuration Example of ET 200S with Fail-Safe Motor Starters and Connection Multiplier

Additional Information on Fail-Safe Motor Starters

All submodules and modules that can be supplied by the PM-D F DC24V PROFIsafe are described in the *ET 200S Motor Starter* manual.

Positioning and Connecting Power Modules

An ET 200S containing fail-safe modules is no different than an ET 200S containing standard modules with regard to the positioning and connection of power modules.

You can position the power modules as you wish. Each TM-P terminal module (for a power module) that you add to the ET 200S opens a new potential group. All sensor and load current supplies of the electronic modules/motor starters that follow are fed from this terminal module.

By placing another TM-P terminal module after an electronic module/motor starter you interrupt the voltage buses (P1/P2) and simultaneously open a new potential group. This allows individual interconnection of sensor and load current supplies.

AUX(iliary) bus (AUX 1)

A TM-P terminal module (for a power module) allows the additional connection of a potential (up to the maximum rated load voltage of the module) which you can apply via the AUX(iliary) bus. You can use the AUX(iliary) bus as follows:

- As a protective conductive bus
- When additional voltage is required

Additional Information about Positioning and Connecting Power Modules

For further information about positioning and connecting power modules refer to the *ET 200S Distributed I/O System Operating Instructions*.

See also

FAQ Safety Classes Standard Modules
<http://support.automation.siemens.com/WW/view/en/39198632>

2.2 Assigning ET 200S modules

Introduction

This section presents the ET 200S module assignments for:

- Fail-safe power modules to terminal modules
- Fail-safe electronic modules to terminal modules
- Power modules to electronic modules/motor starters

Assigning Fail-Safe Power Modules to Terminal Modules

You can use the F-power modules with the following terminal modules:

Table 2- 1 Assigning Fail-Safe Power Modules to Terminal Modules

| F-Power Modules | Terminal Modules | For a Description, See ... |
|--|---|---|
| PM-E F pm DC24V PROFIsafe and PM-E F pp DC24V PROFIsafe | TM-P30S44-A0 (screw-in type) TM-P30C44-A0 (snap-in type) | <i>Terminal Modules</i> manual for the ET 200S distributed I/O system |
| PM-D F DC24V PROFIsafe | TM-PF30S47-F1 (snap-in type) | |

Assigning Fail-Safe Electronic Modules to Terminal Modules

You can use the following fail-safe electronic modules and terminal modules together:

Table 2- 2 Assigning Fail-Safe Electronic Modules to Terminal Modules

| F-Electronic Modules | Terminal Modules | For a Description, See ... |
|--|------------------------------|--|
| 4/8 F-DI DC24V PROFIsafe, 4 F-DI/3 F-DO DC24V PROFIsafe, 4 F-DODC24V/2A PROFIsafe and 1 F-RO DC24V/AC24..230V/5A | TM-E30S46-A1 (screw-in type) | <i>ET 200S Distributed I/O System Operating Instructions</i> |
| | TM-E30C46-A1 (snap-in type) | |
| | TM-E30S44-01 (screw-in type) | |
| | TM-E30C44-01 (snap-in type) | |

Assigning Power Modules to Electronic Modules/Motor Starters

The table below lists the power modules and electronic modules/motor starters you can operate within the same potential group.

Note that certain combinations limit the maximum safety class which can be attained.

Table 2- 3 Assigning Power Modules to Electronic Modules/Motor Starters and Safety Class

| Power Modules | For a Description, See ... | Electronic Module/Motor Starter | Use and achievable SIL/Category/PL | |
|---------------------------|--|---|--|----------------------------|
| PM-E F pm DC24V PROFIsafe | "Power module PM-E F pm DC24V PROFIsafe" | can be used with all released standard electronic modules | Safe shutdown of DO modules of the ET 200S series | SIL2/Cat egory 3/PLd |
| PM-E F pp DC24V PROFIsafe | "Power module PM-E F pp DC24V PROFIsafe" | | | |
| PM-D F DC24V PROFIsafe | "Power module PM-D F DC24V PROFIsafe" | Can only be used for: <ul style="list-style-type: none"> F-DS1e-x, F-RS1e-x fail-safe motor starters (F-MS) Connection multiplier F-CM PM-D F X1 power/expansion module Expansion modules Brake Control xB1 and xB2 | Safe shutdown of motor starters | SIL3/Cat. 4/PLe |
| | | Can be used for the F-motor starters indicated above: Brake Control xB3 and xB4 expansion modules | Safe shutdown of motor starters | SIL2/Cat egory 3/PLd |
| PM-E DC24V | <i>Power Module manual PM-E DC24V (bis 6ES7138-4CA01-0AA0)</i> | can be used with all released standard and fail-safe electronic modules | Power supply to F-DI, F-DO and F-RO modules: up to 6ES7138-4FA03-0AB0 up to 6ES7138-4FC01-0AB0 up to 6ES7138-4FB02-0AB0 up to 6ES7138-4FR00-0AA0 | SIL2/Cat egory 3/PLd |
| | | | Supply of F-DI modules, F-DO modules: 6ES7138-4FA05-0AB0 6ES7138-4FB04-0AB0 | SIL3/Cat. 4/PLe |

| Power Modules | For a Description, See ... | Electronic Module/Motor Starter | Use and achievable SIL/Category/PL | |
|----------------------------|--|--|---|-----------------|
| PM-E DC24..48V | <i>PM-E DC24..48V (6ES7138-4CA50-0AB0) Power Module manual</i> | Can be used with all standard and fail-safe electronic modules | Power supply to F-DI, F-DO and F-RO modules | SIL3/Cat. 4/PLe |
| PM-E DC24..48V/ AC24..230V | <i>PM-E DC24..48V/AC 24..230V (bis 6ES7138-4CB11-0AB0) Power Module manual</i> | | | |

See also

Properties of the PM-E F pm DC24V PROFIsafe Power Module (Page 77)

Properties of the PM-E F pp DC24V PROFIsafe Power Module (Page 98)

Properties of the PM-D F DC24V PROFIsafe Power Module (Page 113)

2.3 Maximum Number of Connectable Modules/Maximum Configuration

Maximum Number of Modules

The modules include the interface module, the power and electronic modules, and the motor starters.

The overall width of an ET 200S is limited to 2 m.

The following restriction applies for IMs as of 6ES7151-1BA01-0AB only when operated in DPV0 mode:

- The maximum number of modules in an ET 200S also depends on the parameter length of the modules. Each ET 200S supports a total of 244 bytes.

For further additional information refer to the *ET 200S Distributed I/O System Operating Instructions*.

Table 2- 4 Parameter Length of F-Modules in Bytes

| Fail-Safe Module | Parameter Length |
|-------------------------------|------------------|
| PM-E F pm DC24V PROFIsafe | 22 bytes |
| PM-E F pp DC24V PROFIsafe | 20 bytes |
| PM-D F DC24V PROFIsafe | 20 bytes |
| 4/8 F-DI DC24V PROFIsafe | 32 bytes |
| 4 F-DI/3 F-DO DC24V PROFIsafe | 32 bytes |
| 4 F-DO DC24V/2A PROFIsafe | 22 bytes |

Example

In the following example, modules with a total parameter length of 234 bytes were used in an ET 200S.

| | | | | | |
|----------------------------|----------------------------|------------------------|--------------------|---------------------|-------------|
| Number and type of modules | : 1 x IM151-1 HIGH FEATURE | + 1 x PM-E DC24V/AC24V | + 5 x F-DI module* | + 2 x F-DO module** | = 9 modules |
|----------------------------|----------------------------|------------------------|--------------------|---------------------|-------------|

| | | | | | |
|------------------|---------------|-----------|-------------|------------|-------------|
| Parameter length | : 27 bytes*** | + 3 bytes | + 160 bytes | + 44 bytes | = 234 bytes |
|------------------|---------------|-----------|-------------|------------|-------------|

* 5 F-DI modules are available: 20 SIL3 or 40 SIL2 inputs

** 2 F-DO modules are available: 8 SIL2/SIL3 outputs

*** 56 bytes in isochronous mode

Power Modules: Maximum Configuration per Potential Group

Table 2- 5 Maximum configuration per potential group

| Power Modules | Maximum Current Carrying Capacity | Connectable Modules/Motor Starters |
|------------------------------|-----------------------------------|---|
| PM-E F pm DC24V PROFIsafe | 10 A | The number of modules that can be connected depends on the total current of all modules in the potential group. The total current may not exceed 10 A. The total current is influenced primarily by the digital output modules. |
| PM-E F pp DC24V PROFIsafe | | |
| PM-D F DC24V PROFIsafe | 10 A briefly* 5 A permanent* | The number of motor starters/modules that can be connected depends on the total current of all motor starters/modules in the potential group. The total current may not exceed 10 A. |

| * Reason: | Current Consumption of the F-Motor Starters | |
|-------------------------------|---|----------------------|
| | U1 (electronics supply) | SG (shutdown groups) |
| Switching time (up to 200 ms) | 0.15 A | 0.25 A |
| Duration (after 200 ms) | 0.15 A | 0.06 A |

ET 200S: Limitations and maximum configuration

For further information about limitations and maximum configuration of the standard ET 200S refer to the *ET 200S Distributed I/O System* Operating Instructions.

2.4 Configuration and Parameter Assignment

Prerequisite

The requirements from chapter Using fail-safe ET 200S modules (Page 16) apply to configuring and assigning parameters for ET 200S fail-safe modules.

Configuration

Follow the usual procedure with *STEP 7 HW Config* to configure fail-safe modules (in the same way as standard ET 200S modules).

Parameter Assignment for Module Properties

To assign parameters for fail-safe module properties, select the module in *STEP 7 HW Config* and select the menu command "Edit > Object Properties".

Parameters are downloaded from the programming device to the F-CPU, where they are stored and then transferred to the fail-safe module.

Parameter Description

You will find a description of assignable fail-safe module parameters in this manual.

PROFIsafe Address and PROFIsafe Address Assignment

You can find a description of PROFIsafe addresses and the address assignment procedure in this manual.

See also

- Assignment of the PROFIsafe address (Page 41)
- Parameters of the PM-E F pm 24 VDC PROFIsafe (Page 89)
- Parameters of the PM-E F pp DC24V PROFIsafe (Page 106)
- Parameters of the PM-D F DC24V PROFIsafe (Page 117)
- Parameters of the EM 4/8 F-DI DC24V PROFIsafe (Page 126)
- EM 4 F-DI/3 F-DO DC24V PROFIsafe parameters (Page 163)
- Parameters of the EM 4 F-DO DC24V/2A PROFIsafe (Page 195)

2.5 Firmware update

Scope

The firmware update is supported by the following fail-safe modules:

- Electronic module 4/8 F-DI DC24V PROFIsafe as of order number 6ES7138-4FA05-0AB0
- Electronic module 4 F-DO DC24V/2A PROFIsafe as of order number 6ES7138-4FB04-0AB0

When should a firmware update be carried out?

After compatible enhancement of functions, you should update the fail-safe electronic modules to the latest firmware version:

Where do I obtain the latest firmware?

The latest firmware is available on the Internet (<http://support.automation.siemens.com/WW/view/en/25536344/133100>). There you will also find a description of the update procedure:

Requirements

 **WARNING**

Check of the firmware version for F-validity

When using a new firmware version, you must check whether the utilized firmware version is approved for use in the respective module.

The appendices for the certificates for S7 Distributed Safety and S7 F/FH Systems specify which firmware version is approved.

- STEP 7 V5.4 SP3 or higher
- The firmware update can only be performed when the F-CPU is in STOP mode.

You can find additional information in the *STEP 7* online help.

Updating firmware

During a firmware update the SF LED of the module flashes at 0.5 Hz as long as no other module fault is pending.

Note

Display the firmware version of the module to verify that the firmware update was performed on the right module.

Note

If the firmware update was aborted, the previous firmware is activated on the module.

Wait until the module is ready to operate again. If the module no longer becomes ready to operate, proceed as follows:

- Switch the power supply of the F-CPU OFF/ON.
- Remove and insert the module.

Then you can perform the firmware update again.

Contact SIMATIC Customer Support if necessary.

Labeling firmware

After the firmware update, you must label the firmware version on the module.

The firmware version is visible below the label.

2.6 Identification and Maintenance Data (I&M data)

Scope

The I&M identification data is supported by the following fail-safe modules:

- Electronic module 4/8 F-DI DC24V PROFIsafe as of order number 6ES7138-4FA05-0AB0
- Electronic module 4 F-DO DC24V/2A PROFIsafe as of order number 6ES7138-4FB04-0AB0

Definition and Properties

Identification and maintenance data (I&M) is information stored in a module that helps you to

- Check the system configuration
- Locate hardware changes in a system
- Troubleshoot a system

Identification data (I data) is information about the module, e.g. the order number and serial number which are printed in part on the housing of the module. I data are manufacturer information on the module and are read-only.

Maintenance data (M data) are system-dependent information, for example location and date of installation. M data are created during configuration and written to the module.

I&M data can be used to unambiguously identify modules online.

2.6.1 I&M data for PROFIBUS DP

As of IM 151-1BA02, these data are available on the ET 200S, as of IM 151-7FA01 or IM 151-8FB00 in the centralized configuration.

Note

Only one DP master can access the I&M data of an ET 200S at any given time.

Reading and writing the I&M data with STEP 7

In *STEP 7*, the I&M data are displayed in the tabs "Module Information – IM 151-1" and "DP Slave properties" (see online help for *STEP 7*).

You can specify the M data of modules (e.g. in a dialog box during the configuration).

The access to the I&M data takes place in accordance with the IEC 61158-6 standard.

In the H system the interface module from which the I&M data is to be read must be available online.

Reading and writing the I&M data without STEP 7

If you wish to use the I&M data without using *STEP 7*, you must carry out the data access in accordance with the specifications of the PROFIBUS Guideline – Order No. 3.502, Version 1.1 May 2003.

In the H system the interface module from which the I&M data is to be read must be addressed (slot 245 or 246). Slot 245 labels the left interface module, slot 246 the right interface module on the BM IM/IM.

Example for reading the I&M data

You can directly access specific I&M data by selecting **Read data record**. A two-level access is necessary for this:

1. Data record 248 has a directory in which the associated data record numbers are given for the various indices (refer to the following table).

Table 2- 6 DS 248 configuration for the ET 200S

| Contents | Length (bytes) | Coding (hex) |
|--|----------------|--------------|
| Header information | | |
| ID of the contents list | 2 | 00 01 |
| Index of the contents list | 2 | 00 00 |
| Length of the following blocks in bytes | 2 | 00 08 |
| Number of blocks | 2 | 00 05 |
| Block information for the I&M data | | |
| SSL-ID | 2 | F1 11 |
| relevant data record number | 2 | 00 E7 |
| Length of the data record | 2 | 00 40 |
| Index | 2 | 00 01 |
| SSL-ID | 2 | F1 11 |
| relevant data record number | 2 | 00 E8 |
| Length of the data record | 2 | 00 40 |
| Index | 2 | 00 02 |
| SSL-ID | 2 | F1 11 |
| relevant data record number | 2 | 00 E9 |
| Length of the data record | 2 | 00 40 |
| Index | 2 | 00 03 |
| SSL-ID | 2 | F1 11 |
| relevant data record number | 2 | 00 EA |
| Length of the data record | 2 | 00 40 |
| Index | 2 | 00 04 |
| 8-byte block information for additional data record objects | | |
| | Σ: 48 | |

2. You can find the part assigned to the respective index of the I&M data under the associated data record number (see table below: *Configuration of the I&M-data*).

All data records which contain I&M data have a length of 64 bytes.

The data records are structured in accordance with the following principle.

Table 2- 7 Basic structure of data records with I&M data

| Contents | Length (bytes) | Coding (hex) |
|---|----------------|--------------|
| Header information | | |
| SSL-ID | 2 | F1 11 |
| Index | 2 | 00 0x |
| Length of the I&M data | 2 | 00 38 |
| Number of blocks with I&M data | 2 | 00 01 |
| I&M data | | |
| Index | 2 | 00 0x |
| I&M data for the respective index (see following table) | 54 | |

Configuration of the I&M-data

The data structure of the I&M data corresponds to the specifications of the PROFIBUS Guideline - Order No. 3.502, Version 1.1 May 2003.

Table 2- 8 Structure of of I&M data

| I&M data | Access | Default | Description |
|---|-------------------------|-------------------------|---|
| Identification data 0: Index 1 (data record 231) | | | |
| MANUFACTURER_ID | read (2 bytes) | 2A hex (= 42 dec) | This is where the name of the manufacturer is saved. (42 dec = SIEMENS AG) |
| ORDER_ID | read (20 bytes) | depending on the module | This is where the order number of the module is saved. |
| SERIAL_NUMBER | read (16 bytes) | depending on the module | Storage location of the module's serial number. The number allows the unambiguous identification of the module. |
| HARDWARE_REVISION | read (2 bytes) | depending on the module | This is where the version of the module is saved. Increments when the version number or firmware of the module alters. |
| SOFTWARE_REVISION | read (4 bytes) | Firmware version | Shows the module's firmware version. If the firmware version increments, then the version of the module also increases (HARDWARE_REVISION). |
| REVISION_COUNTER | read (2 bytes) | 0000 hex | reserved |
| PROFILE_ID | read (2 bytes) | F600 hex | Generic device |
| PROFILE_SPECIFIC_TYPE | read (2 bytes) | 0005 hex | on interface modules |
| IM_VERSION | read (2 bytes) | 0101 hex | Shows the I&M data version. (0101 hex = Version 1.1) |
| IM_SUPPORTED | read (2 bytes) | 000E hex | Shows information about the I&M data. (Index 2 to 4) |
| Maintenance data 1: Index 2 (data record 232) | | | |
| TAG_FUNCTION | read / write (32 bytes) | – | Enter a unique identification (applicable throughout the system) for the module here. |
| TAG_LOCATION | read / write (22 bytes) | – | Enter the location of the module here. |
| Maintenance data 2: Index 3 (data record 233) | | | |
| INSTALLATION_DATE | read / write (16 bytes) | – | Enter the installation date and, if necessary, the respective time for the module. |
| RESERVED | read / write (38 bytes) | – | reserved |
| Maintenance data 3: Index 4 (data record 234) | | | |
| DESCRIPTOR | read / write (54 bytes) | – | Enter a comment regarding the module here. |

2.6.2 I&M data for PROFINET IO

As of IM 151-3BA20 or IM 151-3BB21, this data is available on the ET 200S.

Reading and Writing Identification Data

In *STEP 7*, the identification data are displayed in the "Module Information - IM 151-3" and "Properties ..." tabs (see *STEP 7* Online Help).

You can directly access specific identification data by selecting **Read data record**. Obtain the corresponding part of the identification data under the associated data record index.

The data records are structured as follows:

Table 2- 9 Basic structure of data records with I&M data

| Contents | Length (bytes) | Coding (hex) |
|--|--|--|
| Header information | | |
| BlockType | 2 | I&M0: 0020 I&M1: 0021 I&M2: 0022 I&M3: 0023 |
| BlockLength | 2 | I&M0: 0038 I&M1: 0038 I&M2: 0012 I&M3: 0038 |
| BlockVersionHigh | 1 | 01 |
| BlockVersionLow | 1 | 00 |
| Identification data | | |
| Identification data (see table below) | I&M0 / Index AFF0: 54 I&M1 / Index AFF1: 54 I&M2 / Index AFF2: 16 I&M3 / Index AFF3: 54 | |

The data structures in the data records correspond to the PROFINET IO definitions.

2.6 Identification and Maintenance Data (I&M data)

Table 2- 10 Structure of I&M data

| I&M data | Access | Default | Description |
|--|-------------------------|------------------|---|
| Identification data 0: (data record index AFF0 hex) | | | |
| VendorIDHigh | read (1 bytes) | 00 hex | This is where the name of the manufacturer is saved. (42 dec = SIEMENS AG) |
| VendorIDLow | read (1 bytes) | 2A hex | |
| Order_ID | read (20 bytes) | | Order number of the module |
| IM_SERIAL_NUMBER | read (16 bytes) | - | Serial number (device specific) |
| IM_HARDWARE_REVISION | read (2 bytes) | 1 | Corresponding hardware version |
| IM_SOFTWARE_REVISION | read | Firmware version | Indicates the firmware version of the module. |
| • SWRevisionPrefix | (1 byte) | V, R, P, U, T | |
| • IM_SWRevision_Functional_Enhancement | (1 byte) | 00 - FF hex | |
| • IM_SWRevision_Bug_Fix | (1 byte) | 00 - FF hex | |
| • IM_SWRevision_Internal_Change | (1 byte) | 00 - FF hex | |
| IM_REVISION_COUNTER | read (2 bytes) | - | Provides information on parameter modifications on the module. |
| IM_PROFILE_ID | read (2 bytes) | 0000 | Generic device |
| IM_PROFILE_SPECIFIC_TYPE | read (2 bytes) | 0005 hex | on interface modules |
| IM_VERSION | read | 0101 hex | Provides information about the version of the identification data. (0101 hex = Version 1.1) |
| • IM_Version_Major | (1 byte) | | |
| • IM_Version_Minor | (1 byte) | | |
| IM_SUPPORTED | read (2 bytes) | 000E hex | Provides information about the available identification data. (I&M1 to I&M3) |
| Maintenance data 1: (data record index AFF1 hex) | | | |
| IM_TAG_FUNCTION | Read / write (32 bytes) | - | Define a unique identifier for the module in this record. |
| IM_TAG_LOCATION | Read / write (22 bytes) | - | Define the installation location of the module. |
| Maintenance data 2: (data record index AFF2 hex) | | | |
| IM_DATE | Read / write (16 bytes) | YYYY-MM-DD HH:MM | Enter the installation date of the module here. |
| Maintenance data 3: (data record index AFF3 hex) | | | |
| IM_DESCRIPTOR | Read / write (54 bytes) | - | Define a comment describing the module in this record. |

You can find additional information about identification and maintenance data in the section "Identification and maintenance" of the "From PROFIBUS DP to PROFINET IO (<http://support.automation.siemens.com/WW/view/en/19289930>)" programming manual.

Address Assignment and Installation

3.1 Address assignments in the F-CPU

Address Assignment

The fail-safe modules occupy the following address ranges in the F-CPU:

- For S7 Distributed Safety: in the area of the process image
- For S7 F/FH systems: in the area of the process image

Table 3- 1 Address Assignment in the F-CPU

| F-Module | Occupied Bytes in the F-CPU: | |
|-------------------------------|------------------------------|-------------------|
| | In Input Range | In Output Range |
| PM-E F pm DC24V PROFIsafe | x + 0 to x + 4 | x + 0 up to x + 4 |
| PM-E F pp DC24V PROFIsafe | x + 0 up to x + 4 | x + 0 up to x + 4 |
| PM-D F DC24V PROFIsafe | x + 0 up to x + 4 | x + 0 up to x + 4 |
| 4/8 F-DI DC24V PROFIsafe | x + 0 to x + 5 | x + 0 to x + 3 |
| 4 F-DI/3 F-DO DC24V PROFIsafe | x + 0 up to x + 6 | x + 0 up to x + 4 |
| 4 F-DO DC24V/2A PROFIsafe | x + 0 up to x + 4 | x + 0 up to x + 4 |
| 1 F-RO DC24V/AC24..230V/5A | x.0 and x.1* | — |

x = Module start address
 * The bit addresses can be moved using the "Pack addresses" function.

Addresses Occupied by Useful Data

The useful data occupy the following addresses of the assigned addresses of the fail-safe modules in the F-CPU:

Table 3- 2 Addresses Occupied by Useful Data

| Byte in the F-CPU | Occupied Bits in F-CPU per F-Module: | | | | | | | |
|----------------------------|--------------------------------------|---|---|---|---|-----------|-----------|-----------|
| | 7 | 6 | 5 | 4 | 3 | 2 | 1 | 0 |
| PM-E F pm DC24V PROFIsafe: | | | | | | | | |
| x + 0 | — | — | — | — | — | Channel 2 | Channel 1 | Channel 0 |
| PM-E F pp DC24V PROFIsafe: | | | | | | | | |
| x + 0 | — | — | — | — | — | — | — | Channel 0 |

3.2 Assignment of the PROFIsafe address

| Byte in the F-CPU | Occupied Bits in F-CPU per F-Module: | | | | | | | |
|--------------------------------|--------------------------------------|-----------|-----------|-----------|-----------|-----------|-----------|------------------------------|
| | 7 | 6 | 5 | 4 | 3 | 2 | 1 | 0 |
| PM-D F DC24V PROFIsafe: | | | | | | | | |
| x + 0 | — | — | Channel 5 | Channel 4 | Channel 3 | Channel 2 | Channel 1 | Channel 0 |
| 4/8 F-DI DC24V PROFIsafe: | | | | | | | | |
| x + 0 | Channel 7 | Channel 6 | Channel 5 | Channel 4 | Channel 3 | Channel 2 | Channel 1 | Channel 0 |
| 4 F-DI/3 F-DO DC24V PROFIsafe: | | | | | | | | |
| x + 0 (inputs) | — | — | — | — | Channel 3 | Channel 2 | Channel 1 | Channel 0 |
| x + 0 (outputs) | — | — | — | — | — | Channel 2 | Channel 1 | Channel 0 |
| 4 F-DO DC24V/2A PROFIsafe: | | | | | | | | |
| x + 0 | — | — | — | — | Channel 3 | Channel 2 | Channel 1 | Channel 0 |
| 1 F-RO DC24V/AC24..230V/5A: | | | | | | | | |
| x + 0 | — | — | — | — | — | — | 0 | Channel 0 (Readback channel) |
| x = Module start address | | | | | | | | |

⚠ WARNING

You may only access the addresses occupied by useful data. The other address ranges occupied by the F-modules are assigned for functions including safety-related communication between the F-modules and F-CPU in accordance with PROFIsafe.

With the 1oo2 evaluation of sensors, only the less significant channel of the channels that are grouped as a result of the 1oo2 sensor evaluation can be accessed in the safety program.

Additional Information

Detailed information about fail-safe I/O access can be found in the *S7 Distributed Safety, Configuring and Programming* manual or the *S7 F/FH Systems, Configuring and Programming* manual.

3.2 Assignment of the PROFIsafe address

PROFIsafe address

Every fail-safe module has an own PROFIsafe address. Before installing fail-safe modules, you must set the PROFIsafe address on each F-module.

PROFIsafe Address Assignment

The PROFIsafe addresses (F_source_address, F_destination_address) are assigned automatically when you configure the fail-safe modules in *STEP 7*.

You can view the F_destination_address in binary format in *HW Config* in the Object properties of the fail-safe modules in the "DIP switch setting" parameter. You read the PROFIsafe address from the parameter assignment dialog box and set it on the fail-safe module using the address switch.

You can edit the configured F_destination_address in *HW Config*. To prevent addressing errors, however, we recommend that you use the automatically assigned F_destination_address.

Address Switch for Setting PROFIsafe Addresses

The address switch (10-pin DIP switch) is located on the left-hand side of every fail-safe module. Use this address switch to set the PROFIsafe address (F_destination_address) of the F-module.

Note

Fail-safe modules in ET 200S can only be operated in safety mode.

Setting the Address Switch

Before installing the F-module, ensure that the address switch is set correctly.

Valid range of the PROFIsafe addresses: 1 to 1022. The figure below shows an example of an address switch setting.

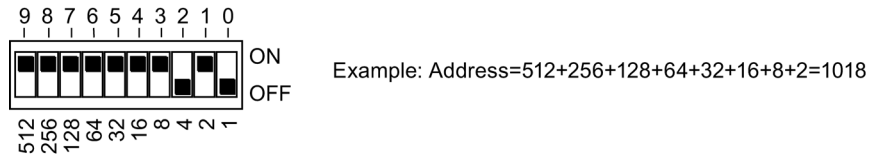

Figure 3-1 Example for Setting the Address Switch (DIP Switch)

Note

An address switch of the smallest possible dimensions is installed for reasons of space saving. This makes it sensitive to pressure and objects with sharp edges. Always use a suitable tool to operate the address switch.

Diverse tools suitable for activating the address switch are available on the market, for example, the Grayhill DIPSTICK. A ballpoint pen may be employed if used carefully. It is imperative to avoid any burring which would prevent the switch from reaching its home position. Therefore, DO NOT use screwdrivers or knives to operate the address switch.

Rules for Address Assignment

WARNING

Observe the following rules when assigning addresses:

- Make sure that the address switch setting on the module matches the PROFIsafe address in the *HW Config*.

- **Rule for PROFIBUS subnets:**

The switch setting on the F-I/O address switch, i.e. its PROFIsafe destination address, must be unique within the network* and station** (system-wide). You can assign up to 1,022 different PROFIsafe destination addresses.

Exception: The fail-safe I/Os in different I slaves may have the same PROFIsafe destination address assigned, as they are only addressed within the station, that is, by the F-CPU in the I-slave.

Rules for Ethernet subnets and combined PROFIBUS and Ethernet subnet configurations:

The address switch setting on the fail-safe I/O, i.e. the PROFIsafe destination address only*** has to be unambiguous within the Ethernet subnet, including all sublevel PROFIBUS subnets and station-wide** (system-wide). You can assign up to 1,022 different PROFIsafe destination addresses.

Exception: The fail-safe I/Os in different I slaves may have the same PROFIsafe destination address assigned, as they are only addressed within the station, that is, by the F-CPU in the I-slave.

The networked nodes of an Ethernet subnet are characterized by having IP addresses with a shared subnet address, i.e. the IP addresses are congruent with the "1" digits in the subnet mask.

Example:

IP address: 140.80.0.2

Subnet mask: 255.255.0.0 = 11111111.11111111.00000000.00000000

Meaning: Bytes 1 and 2 of the IP address define the subnet; subnet address = 140.80.

*: A network consists of one or more subnets. "Network-wide" = across subnet boundaries.

** : "Station-wide" means one station in *HW Config* (e.g. an S7-300 station or an I-slave)

***: Beyond Ethernet subnet boundaries if cyclic PROFINET IO communication (RT communication) is excluded.

3.3 Installing

Installing the fail-safe modules

The fail-safe power modules, electronic modules, and terminal modules are part of the ET 200S range of modules. They are installed using the same procedure as for all standard modules in an ET 200S.

Detailed information about module installation is available in the *ET 200S Distributed I/O System* Operating Instructions.

Installation dimensions

Note that fail-safe modules are 30 mm wide (twice the width of standard ET 200S modules). Otherwise, the information provided in the *ET 200S Distributed I/O System* Operating Instructions applies.

Wiring and Fitting Modules

4.1 Introduction

 **WARNING**

In order to prevent hazardous risks to persons or to the environment, you must not under any circumstances override safety functions or implement any measures that cause safety functions to be bypassed or that result in the bypassing of safety functions. The manufacturer is not liable for the consequences of such manipulation or for damages that result from failure to heed this warning.

This chapter

This chapter covers the special features involved in wiring and fitting fail-safe modules. Information about this subject that applies to both ET 200S with fail-safe modules and ET 200S with standard modules can be found in the *ET 200S Distributed I/O System* operating instructions.

4.2 Safe Functional Extra-Low Voltage (SELV) for Fail-Safe Modules

Safe Functional Extra-Low Voltage

 **WARNING**

Fail-safe modules must be operated with safe functional extra-low voltage (SELV, PELV). This means that these modules, even in the event of a fault, can only have a maximum voltage of U_m . The following applies for all fail-safe modules:

$$U_m < 60.0 \text{ V}$$

You can find additional information about safe functional extra-low voltage in the data sheets, for example, of the applicable power supplies.

All system components that can supply electrical energy in any form whatsoever must fulfill this condition.

Each additional power circuit (24 VDC) installed in the system must be operated on safe functional extra-low voltage (SELV, PELV). Refer to the relevant data sheets or contact the manufacturer.

4.2 Safe Functional Extra-Low Voltage (SELV) for Fail-Safe Modules

Sensors and actuators with an external power supply can also be connected to F-modules. Make sure here, too, that power is supplied to these components from safe functional extra-low voltage. The process signal of a 24 VDC digital module may not exceed a fault voltage U_m in the event of a fault.

 **WARNING**

All voltage sources, for example, internal 24 VDC load voltage supplies, external 24 VDC load voltage supplies and 5 V DC bus voltage, must be electrically connected externally. This prevents potential differences from causing voltage additions at the individual voltage sources which would cause the fault voltage U_m to be exceeded.

Ensure that line cross-sections are sufficient for electrical connection in accordance with the ET 200S configuration guidelines (see *ET 200S distributed I/O system* operating instructions).

Power supply Requirements for Compliance with NAMUR Recommendations

Note

Always use power packs or power supplies (230 VAC --> 24 VDC) with a power failure ride-through of at least **20 ms** to ensure compliance with NAMUR recommendation NE 21, IEC 61131-2 and EN 298. The latest up-to-date information on PS components is available on the Internet (<http://www.siemens.com/industrymall>).

These requirements also apply, of course, to power packs and power supplies which are not manufactured to ET 200S or S7-300/-400 configuration standards.

See also

Specifications for Nominal Line Voltages, Isolation Tests, Protection Class, and Type of Protection (Page 73)

4.3 Wiring fail-safe modules

Same Wiring Procedure as for ET 200S

Fail-safe power modules, electronic modules and terminal modules are part of the ET 200S range of modules. They are wired using the same procedure as for all standard modules in an ET 200S.

Refer to the *ET 200S Distributed I/O System* operating instructions for detailed information on wiring and fitting the modules and IM 151.

| |
|--|
|  WARNING |
|--|

| |
|---|
| When assigning signals of the F-DI module, remember that signals should only be routed within a cable or sheathed cable if: |
|---|

- | |
|---|
| <ul style="list-style-type: none">• A short-circuit in the signals does not conceal a serious safety risk• Signals are supplied by different sensor supplies of this F-DI module |
|---|

Mounting Rails

The ET 200S distributed I/O system is installed on a mounting rail according to EN 60715 (35 x 7.5 mm or 35 x 15 mm).

Appropriate surface designs are:

- Steel strip according to Appendix A of EN 60715, or
- Tinned steel strip. We recommend the following mounting rails for this purpose:
 - 6ES5710-8MA11 (length: 483 mm)
 - 6ES5710-8MA21 (length: 530 mm)
 - 6ES5710-8MA31 (length: 830 mm)
 - 6ES5710-8MA41 (length: 2000 mm)

Note

If you use rails from other manufacturers, please ensure that these have the properties necessary to withstand your climatic ambient conditions.

4.4 Inserting and Removing Fail-Safe Modules

Terminal assignment of the TMs

The terminal assignment of the TMs depends on the installed power or electronic module.

See also

Wiring of the PM-E F pm DC24V PROFIsafe (Page 84)

Wiring of the PM-E F pp DC24V PROFIsafe (Page 104)

Wiring of the PM-D F DC24V PROFIsafe (Page 117)

Wiring of the EM 4/8 F-DI DC24V PROFIsafe (Page 125)

Wiring of the EM 4 F-DI/3 F-DO DC24V PROFIsafe (Page 162)

Wiring diagram of the EM 4 F-DO DC24V/2A PROFIsafe (Page 191)

Wiring of EM 1 F-RO DC24V/AC24..230V/5A (Page 208)

4.4 Inserting and Removing Fail-Safe Modules

Inserting and Removing Electronic Modules

In ET 200S, the same procedure is used to insert and remove both fail-safe modules and standard modules on terminal modules (see ET 200S Distributed I/O System manual).

Inserting and Removing Electronic Modules during Operation

F-modules can be inserted and removed during operation in exactly the same way as standard modules in ET 200S.

Note

Hot-swapping fail-safe modules in ET 200S during operation generates a communication error on the F-CPU.

You must acknowledge this communication error in your safety program. (For information on the response of the F-system after communication errors, output of a fail-safe value and user acknowledgment, refer to the *S7 Distributed Safety, Configuration and Programming* or *S7 F/FH Systems, Configuring and Programming*).

If the communication error is not acknowledged, the useful data of the F modules remain passivated (inputs and outputs in "0" state).

Conditions for Insertion and Removal during Operation

The table below lists the F-modules which support hot-swapping and the conditions under which this is possible:

Table 4- 1 Conditions for Hot-Swapping Fail-Safe Modules

| Module | Insertion and Removal | Conditions |
|---------------------------------------|-----------------------|-----------------------------------|
| Interface module | No | — |
| Fail-safe power module (PM E-F pm) | Yes | Load voltage must be switched off |
| Fail-safe power module (PM E-F pp) | Yes | |
| Fail-safe power module (PM D-F) | Yes | |
| Fail-safe electronic module (F-DI) | Yes | — |
| Fail-safe electronic module (F-DI/DO) | Yes | Load voltage must be switched off |
| Fail-safe electronic module (F-DO) | Yes | Load voltage must be switched off |
| Fail-safe electronic module (F-RO) | Yes | Load voltage must be switched off |

Spare parts case for a fail-safe module

You can replace a fail-safe module by a successor module with a higher order number. The new fail-safe module takes on any existing configuration and then behaves like the replaced fail-safe module.

Remember to Set the PROFIsafe Address

When replacing fail-safe modules, ensure that the address switch (DIP switch) setting of the new fail-safe module is identical to that of the replaced fail-safe module.

See also

Assignment of the PROFIsafe address (Page 41)

4.5 Requirements for Sensors and Actuators

General Requirements for Sensors and Actuators

Please note the following important information for safety-related use of sensors and actuators:

 **WARNING**

The use of sensors and actuators is beyond our sphere of influence. We have equipped our electronics with such safety engineering features as to leave 85% of the maximum permissible hazardous faults probability for sensors and actuators to you (this corresponds to the recommended distribution between sensing devices, actuating devices and electronic switching for input, processing and output in safety engineering).

Note, therefore, that instrumentation with sensors and actuators bears a considerable **safety responsibility**. Remember, too, that sensors and actuators do not generally reach proof-test intervals of 10 years as defined in IEC 61508:2000 without considerable loss of safety.

The probability of hazardous faults and the rate of hazardous faults of safety functions must comply with an SIL-defined upper limit. You will find a listing of values achieved by F-modules in the technical specifications of the F-modules under "Safety characteristics".

To achieve SIL3 (Category 4/PLe), suitably qualified sensors are necessary.

Additional Sensor Requirements

General rule: A single-channel sensor is sufficient to achieve SIL2/Category 3/PLd. However, the sensors must be wired to two channels in order to achieve SIL3/Category 4/PLe. However, to achieve SIL2/Category 3/PLd with a single-channel sensor, the sensor itself must be SIL2/Category 3/PLd-capable, otherwise the sensor must be wired to two channels in order to achieve this safety level.

Duration Requirements for Sensor Signals

 **WARNING**

Observe the following requirements for sensor signals:

- In order to guarantee accurate detection of sensor signals by the F-DI module, you must ensure that the sensor signals have a defined minimum duration.
- Reliable pulse detection requires an interval between two signal changes (pulse duration) greater than the PROFIsafe monitoring time.

Reliable detection by the F-DI module

The table below lists the minimum duration of sensor signals for the F-DI module. This depends on the parameter settings made in *STEP 7* for the short-circuit test and the input delay.

Table 4- 2 Minimum Duration of Sensor Signals to Allow Correct Detection by F-DI-Module

| Short-Circuit Test Parameter | Programmed Input Delay | | |
|------------------------------|------------------------|-------|-------|
| | 0.5 ms | 3 ms | 15 ms |
| Deactivated | 7 ms | 9 ms | 23 ms |
| Activated | 7 ms | 12 ms | 37 ms |

Reliable Detection by the Safety Program on the F-CPU

Information about the times required for the reliable detection of sensor signals in the safety program is available in "*Fail-Safe Modules*" of the *Safety Engineering in SIMATIC S7* system description.

Additional Requirements for Actuators

The F-modules test the outputs at regular intervals. To do so, the F-module briefly switches off the activated outputs. Duration of these test pulses:

- Dark period < 1 ms

Rapid response actuators may briefly drop out during the test. If your process does not tolerate this, you must use actuators with a sufficient lag (> 1 ms).

| |
|---|
|  WARNING |
| <p>If the actuators are operated at voltages greater than 24 VDC (for example, 230 VDC) or if the actuators switch higher voltages, safe isolation must be ensured between the outputs of a fail-safe output module and the components carrying a higher voltage (in accordance with EN 50178).</p> <p>This is generally the case for relays and contactors. Particular attention must be paid to this issue for semiconductor switching devices.</p> |

See also

Using fail-safe ET 200S modules (Page 16)

Assignment of the PROFIsafe address (Page 41)

Technical Specifications of PM-E F pm DC24V PROFIsafe (Page 93)

Technical Specifications for PM-E F pp DC24V PROFIsafe (Page 109)

Technical Specifications of the PM-D F DC24V PROFIsafe (Page 120)

Technical Specifications of the EM 4/8 F-DI DC24V PROFIsafe (Page 153)

Input applications of EM 4 F-DI/3 F-DO DC24V PROFIsafe (Page 167)

Technical specifications of the EM 4 F-DI/3 F-DO DC24V PROFIsafe (Page 182)

Technical Specifications of the EM 4 F-DO DC24V/2A PROFIsafe (Page 200)

Technical specifications of the EM 1 F-RO DC24V/AC24..230V/5A (Page 212)

Diagnostics

5.1 Reactions to Faults

Safe State (Safety Concept)

The basic principle behind the safety concept is the existence of a safe state for all process variables.

Note

For digital F-modules, this safe state is the value "0". This applies to both sensors and actuators.

Reactions to Faults and startup of the F-system

The safety function requires that fail-safe values (safe state) be applied to the fail-safe module instead of process values (**passivation of the fail-safe module**) in the following situations:

- When the F-system is started up
- If errors are detected during safety-related communication between the F-CPU and the F-module via the PROFIsafe safety protocol (communication error).
- If fail-safe I/O or channel faults occur (for example wire break, discrepancy error)

Faults detected are entered in the diagnostic buffer of the F-CPU and reported to the safety program in the F-CPU.

F-modules cannot save errors as retentive data. When the system is powered down and then restarted, any faults still existing are detected again during startup. However, you have the option of saving faults in your safety program.

| |
|--|
|  WARNING |
|--|

| |
|--|
| Channel errors do not trigger any diagnostic reactions or error handling for channels that have been set to "deactivated" in <i>STEP 7</i> , even when this channel is affected indirectly by a channel group fault ("Channel activated/deactivated" parameter). |
|--|

Remedying faults in the F-system

To remedy faults in your F-system, proceed as described in IEC 61508-1:1998 Section 7.15.2.4 and IEC 61508-2:2000 Section 7.6.2.1 e.

The following steps must be performed:

1. Diagnosis and repair of the fault
2. Revalidation of the safety function
3. Recording in the service report

Fail-safe value output for F-modules

If channels are passivated **with F-DI modules**, the F-system provides fail-safe values for the safety program instead of the process values applied to the fail-safe inputs.

- For F-DI modules, this is always the fail-safe value "0".

In the case of F-DO modules and PM-E F pm DC24V PROFIsafe, if passivation occurs the F-system transfers fail-safe values (0) to the fail-safe outputs instead of the output values provided by the safety program. The output channels are de-energized. This also applies when the F-CPU goes into STOP mode. You cannot program fail-safe values.

Depending on the F-system used and the type of fault that occurred, (F-I/O, channel or communication fault), fail-safe values are used either for the affected channel only or for all channels of the fail-safe module involved.

In S7 distributed safety F-systems up to V5.3, the entire F-module is passivated when a channel fault occurs. Starting with S7 distributed safety V5.4, F-modules as of the indicated order numbers can also be passivated on a channel-level basis.

Reintegration of a Fail-Safe Module

The system changes from fail-safe to process values (reintegration of an F-module) either automatically or only after user acknowledgment in the safety program. It may be necessary to remove and insert the F-module to clear certain channel faults. For an exact list of such faults, see section "*Power module PM-E F pm DC24V PROFIsafe*" to "*Digital electronic module4 F-DO DC24V/2A PROFIsafe*" in the "Causes of errors and troubleshooting" tables.

After reintegration, the following occurs:

- For a fail-safe DI module, the process values pending at the fail-safe inputs are provided for the safety program
- For a fail-safe DO module, the output values provided in the safety program are again transferred to the fail-safe outputs

Additional Information on Passivation and Reintegration

For further information about fail-safe I/O access refer to the *S7 Distributed Safety, Configuring and Programming* manual or the *S7 F/FH Systems, Configuring and Programming* manual.

Reaction of the F-module with inputs to communication errors

The F-module with inputs responds differently to communication errors compared to other errors.

If a communication error is detected, the current process values remain set at the inputs of the F module and the channels are not passivated. The current process values are sent to the F-CPU and are passivated in the F-CPU.

See also

Properties of the PM-E F pm DC24V PROFIsafe Power Module (Page 77)

Properties of the PM-E F pp DC24V PROFIsafe Power Module (Page 98)

Properties of the PM-D F DC24V PROFIsafe Power Module (Page 113)

Properties of the 4/8 F-DI DC24V PROFIsafe Digital Electronic Module (Page 122)

Properties of the 4 F-DI/3 F-DO DC24V PROFIsafe Digital Electronic Module (Page 157)

Properties of the 4 F-DO DC24V/2A PROFIsafe Digital Electronic Module (Page 186)

Properties of the EM 1 F-RO DC24V/AC24...230V/5A (Page 203)

5.2 Fault Diagnostics

Purpose of diagnostics

Diagnostics are used to determine whether error-free signal acquisition is taking place at the fail-safe modules. Diagnostics information is assigned either to a single channel or to the entire F-module.

Diagnostics functions are not safety critical

None of the diagnostic functions (displays and messages) are safety critical and therefore not designed to be safety-related functions. Consequently, they are not tested internally.

Diagnostic Options for Fail-Safe Modules in ET 200S

The following diagnostic options are available for fail-safe modules:

- LED display on the module front panel
- Diagnostic functions of F-modules (slave diagnostics in accordance with IEC 61784-1).

Non-Programmable Diagnostic Functions

Fail-safe electronic and power modules provide diagnostic functions which cannot be programmed by the user. This means that the diagnostic functions are always activated, and are automatically made available by the F-module in *STEP 7* and passed on to the F-CPU in the event of a fault.

Programmable Diagnostic Functions

You can program (activate) certain diagnostic functions in *STEP 7*:

- Wire-break detection for the F-DI/F-DO module, the F-DO module and the PM-E F pm
- Short-circuit monitoring for the F-DI/F-DO module and F-DI module

| |
|--|
|  WARNING |
| Diagnostic functions should be activated or deactivated in accordance with the application. |

Diagnostics by LED Display

Every fail-safe power and electronic module (with the exception of the EM 1 F-RO DC24V/AC24..230V/5A) indicates faults by means of its SF LED (group fault LED). The SF-LED lights up as soon as a diagnostic function is triggered by the F-module. The SF LED flashes as long as a cleared fault has not been acknowledged (as of release version 02.) It goes dark when all faults have been eliminated and acknowledged.

The power module is also equipped with a PWR LED which displays the status of the load voltage supply of the potential group.

The 4/8 F-DI DC24V PROFIsafe electronic module is equipped with two additional fault LEDs (1VsF and 2VsF) that display faults for the two internal sensor power supplies.

The 4 F-DI/3 F-DO DC24V PROFIsafe electronic module also has a fault LED (VsF) that displays the faults of the internal sensor supply, and a channel LED, the channel LED and the SF LED light up red as soon as a diagnostic function is triggered by the F-module. The LEDs go dark when all faults have been eliminated.

The SF LED flashes until you acknowledge passivation following a module fault.

Slave diagnostics

Slave diagnostics complies with IEC 61784-1. The fail-safe electronic and power modules support slave diagnostics in exactly the same way as standard ET 200S modules.

Information about the general structure of slave diagnostics for the ET 200S and the fail-safe modules can be found in the *ET 200S Distributed I/O System* operating instructions. A description of channel-specific diagnostics for fail-safe modules is presented below.

Channel-specific diagnostics

As with the ET 200S, there are three bytes available for channel-specific diagnostics, starting at byte 35. Up to 9 channel-specific diagnostic messages are possible per station. Channel-specific diagnostics for fail-safe modules are structured as follows.

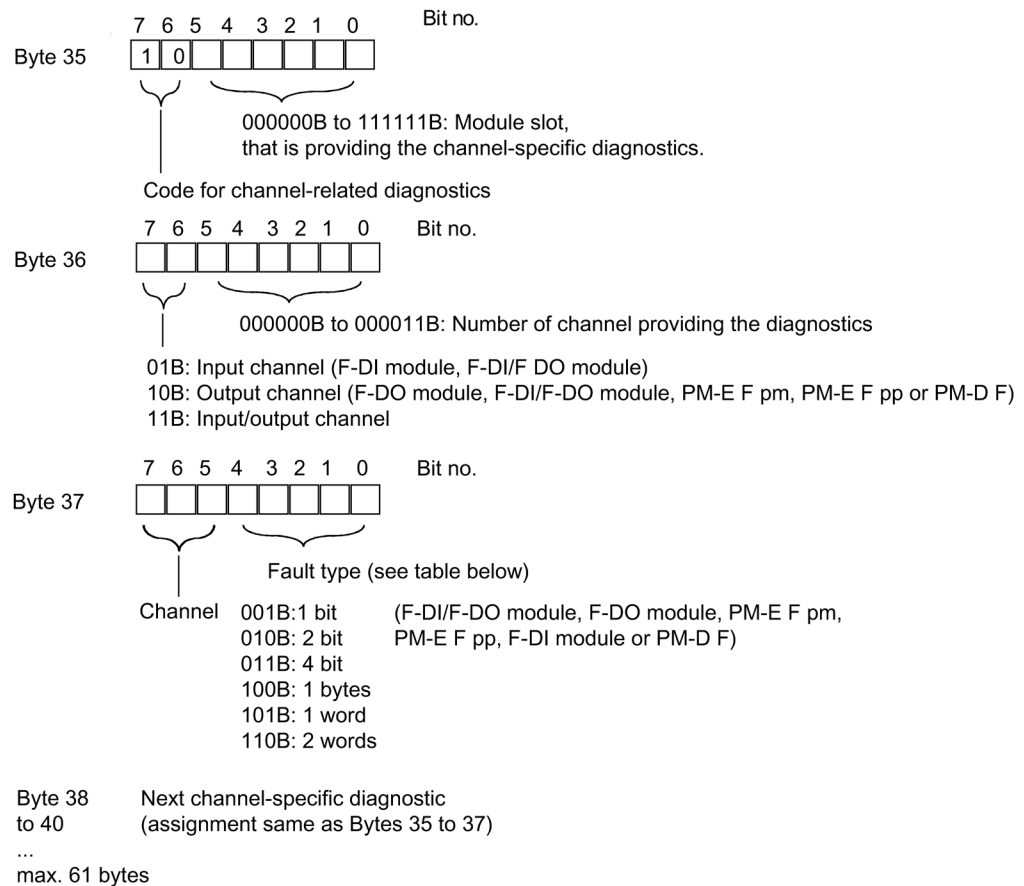

Figure 5-1 Structure of Channel-specific diagnostics

Note

The module slot coding is contained in byte 35, bits 0 to 5. The following applies:
 displayed number + 1 = module slot
 (0 = slot 1; 1 = slot 2, and so forth)

Note

Channel-specific diagnostics data are always updated to the current diagnostic function in the diagnostic message frame. Older, successive diagnostic functions are not deleted.

Remedy: Evaluate the valid, current length of the diagnostic message frame. To do this, use the parameter RET_VAL of the SFC 13 in *STEP 7*.

Possible Fault Types of Fail-Safe Modules

The table below lists the messages of the IM 151-1 HIGH FEATURE. When using the IM 151-7 F-CPU or IM 151-8 DP/PN F-CPU, you can obtain detailed diagnostic information using *HW diagnostics* in *STEP 7*.

Table 5- 1 Fault types of channel-related diagnostics (apart from EM 1 F-RO DC24V/AC24..230V/5A)

| Fault Type PROFIBUS DP/ PROFINET IO | Diagnostic Function in STEP 7 | F-Module | Special Meaning for F-Modules |
|---|--|---|---|
| 1 _H | Short-circuit | EM 4/8 F-DI EM 4 F-DI/3 F-DO | Short-circuit to L+ on the unconnected sensor cable Short-circuit to sensor supply L+ Short-circuit to ground or sensor supply failure Internal fault at the read circuit/test circuit |
| | | PM-E F pm DC24V 4 F-DO 4 F-DI/3 F-DO | Defective P-output driver Short-circuit of output to L+, or defective output driver Defective M-output driver Short-circuit of output to M, or output driver failure |
| | | 4 F-DI/3 F-DO | Overload |
| 4 _H | Overload | PM-E F pm DC24V 4 F-DO | Overcurrent at output driver |
| 5 _H | Overtemperature | all apart from 4 F-DI/3 F-DO | — |
| 6 _H | Wire break | PM-E F pm DC24V 4 F-DO | Wire break |
| 9 _H | Fault | all | RAM fault EPROM fault Processor failure (expected DIP switch value / actual DIP switch value) Processor error Time monitoring activated |
| 10 _H | Parameter assignment error | all | Parameter assignment error |
| 11 _H | Sensor voltage or load voltage missing | all | External auxiliary supply missing |
| 13 _H | Communication error | all | CRC (cyclic redundancy check) error in data message frame Monitoring time for data message frame exceeded |
| 19 _H | Safety-related shutdown | 4/8 F-DI 4 F-DI/3 F-DO | Discrepancy error |
| | | PM-E F pm DC24V PM-E F pp DC24V 4 F-DI/3 F-DO | Switching frequency exceeded |

Reaction of F-Modules to Module Failure

The following events occur following a serious internal fault in the F-module, causing F-module failure:

- The connection to the backplane bus is interrupted and the fail-safe I/O are passivated
- Diagnostics are not transmitted from the F-module and the default diagnostic message "Module Fault" is reported
- The SF LED of the corresponding F-module illuminates

Specific Information about Diagnostic Functions

All module-specific diagnostic functions, possible causes and their troubleshooting can be found in the sections "*Power module PM-E F pm DC24V PROFIsafe*" to "*Digital electronic module 1 F-RO DC24V/AC24..230V/5A*".

These sections also provide information about the status and diagnostic functions indicated by the LEDs on the front panel of the relevant F-module.

Reading Out Diagnostic Functions

You can display the cause of a fault in the *STEP 7* module diagnostics (see *STEP 7 Online Help*).

You can read the diagnostic functions (slave diagnostics) by calling SFC 13 in the standard user program (see *System and Standard Functions* reference manual).

See also

Diagnostic Functions of the PM-E F pm DC24V PROFIsafe (Page 91)

Diagnostic functions of the PM-E F pp DC24V PROFIsafe (Page 107)

Diagnostic Functions of PM-D F DC24V PROFIsafe (Page 118)

Diagnostic functions of EM 4/8 F-DI DC24V PROFIsafe (Page 149)

Diagnostic functions of EM 4 F-DI/3 F-DO DC24V PROFIsafe (Page 179)

Diagnostic Functions of the EM 4 F-DO DC24V/2 A PROFIsafe (Page 196)

Diagnostic functions of EM 1 F-RO DC24V/AC24..230V/5A (Page 212)

General Technical Specifications

6.1 Introduction

This chapter

This chapter provides information about fail-safe modules:

- The most important standards and approvals
- General technical specifications

General Technical Specifications

The General Technical Specifications comprise the standards and test values with which the fail-safe modules must comply when installed in an ET 200S and the test criteria for fail-safe modules on the one hand, and requirements of fail-safe modules in terms of shipping, storage and environmental conditions.

6.2 Standards and Approvals

CE approval



The ET 200S fail-safe modules meet the requirements and protection targets of the following EC Directives and comply with the harmonized European standards that have been issued for PLCs in the official gazettes of the European Community:

- 2006/108/EC "Electrical equipment for use within specific voltage limits" (Low-voltage directive)
- 2004/108/EC "Electromagnetic Compatibility" (EMC Directive)
- 94/9/EC "Equipment and Protective Systems Intended for Use in Potentially Explosive Atmospheres" (Explosion Protection Guideline)
- 2006/42/EC "Machinery Directive"

The EC declarations of conformity are kept available for the relevant authorities at:

Siemens Aktiengesellschaft
Industry Sector
I IA AS FA WF AMB 3
P.O. Box 1963
D-92209 Amberg, Germany

UL approval



Underwriters Laboratories Inc., in accordance with

- UL 508 (Industrial Control Equipment)

CSA approval



Canadian Standard Association (CSA) in accordance with

- C22.2 No. 142 (Process Control Equipment)

or



Underwriters Laboratories Inc., in accordance with

- UL 508 (Industrial Control Equipment)
- CSA C22.2 No. 142 (Process Control Equipment)

or



Underwriters Laboratories Inc., in accordance with

- UL 508 (Industrial Control Equipment)
- CSA C22.2 No. 142 (Process Control Equipment)
- UL 1604 (Hazardous Location)
- CSA-213 (Hazardous Location)

APPROVED for use in
Class I, Division 2, Group A, B, C, D Tx;
Class I, Zone 2, Group IIC Tx

Note

The nameplate on each module indicates the currently valid approvals.

FM approval



Factory Mutual Research (FM) to

- Approval Standard Class Number 3611, 3600, 3810

APPROVED for use in
Class I, Division 2, Group A, B, C, D Tx;
Class I, Zone 2, Group IIC Tx



In accordance with EN 60079-15 (Electrical Apparatus for Potentially Explosive Atmospheres; Type of Protection "n")

II 3 G Ex nA II Parts 4 to 5

 **WARNING**

There is a risk of personal injury or damage to property.

In areas exposed to explosion hazard, personal injury or damage to property can occur if plug-in connections are disconnected during operation.

Before disconnecting plug-in connections in areas exposed to explosion hazard, always de-energize the distributed I/O first.

Marking for Australia



The fail-safe modules of the ET 200S satisfy the requirements of AS/NZS 2064 (Class A).

IEC 61131

The fail-safe modules of the ET 200S satisfy the requirements and criteria of IEC 61131-2 (Programmable Controllers - Part 2: Equipment Requirements and Tests).

PROFIBUS Standard

The ET 200S distributed I/O system is based on the IEC 61784-1 standard.

Shipbuilding approval

Submitted to the following classification bodies
(exception: PM-D F DC24V PROFIsafe to GL (German Lloyd) only):

ABS (American Bureau of Shipping)

BV (Bureau Veritas)

DNV (Det Norske Veritas)

GL (Germanischer Lloyd)

LRS (Lloyds Register of Shipping)

Class NK (Nippon Kaiji Kyokai)

Use in Industry

SIMATIC products are designed for use in industrial environments.

| Field of Application | Requirement Relating to | |
|----------------------|-------------------------|--------------------------|
| | Emitted Interference | Immunity to Interference |
| Industry | EN 61000-6-4 | EN 61000-6-2 |
| | | |

Use in Residential Areas

ET 200S applications in residential areas must be compliant with limit class B to EN 61000-6-4 for emission of radio interference.

Suitable measures for achieving limit class B for emission of radio interference are:

- Installing the ET 200S in grounded control cabinets/control boxes
- Use of filters in power supply lines

TÜV Certificate and Standards

The fail-safe modules are certified in accordance with standards and guidelines in terms of functional safety. Refer to the report on the safety certificate (TÜV certificate) and the associated annex for more details in this regard. The current TÜV documents can be found on the Internet (<http://support.automation.siemens.com/WW/view/en/12461959/133300>).

Requesting TÜV Certificates

You can request copies of the TÜV certificate and the accompanying report from the following address:

Siemens Aktiengesellschaft
Industry Sector
I IA AS FA WF AMB 3
P.O. Box 1963
D-92209 Amberg, Germany

See also

Safety engineering in SIMATIC S7
(<http://support.automation.siemens.com/WW/view/en/12490443>)

6.3 Electromagnetic Compatibility

Introduction

This chapter presents information about immunity to interference of fail-safe modules and about EMC conformity.

Definition of EMC

Electromagnetic compatibility is the ability of an electrical device to function in its electromagnetic environment in a satisfactory manner without affecting this environment.

Fail-safe modules also comply with the requirements of the EMC law for the European Single Market. As a requirement, the ET 200S distributed I/O system must comply with the specifications and guidelines for electrical configuration.

Pulse-Shaped Interference

The following table presents the electromagnetic compatibility of fail-safe modules with regard to pulse-shaped interference.

| Pulse-Shaped Interference | Tested With | Degree of Severity |
|--|---|--|
| Electrostatic discharge in accordance with IEC 61000-4-2 (DIN VDE 0843 Part 2) | 8 kV 6 kV (cabinet installation mandatory) 4 kV (no cabinet installation) | 3 (air discharge) 3 (contact discharge) |
| Burst pulse (rapid transient interference) in accordance with IEC 61000-4-4 (DIN VDE 0843 Part 4) | 2 kV (supply line) 2 kV (signal line) | 3 4 |
| Zone B in accordance with IEC 61131-2 Surge in accordance with IEC 61000-4-5 (DIN VDE 0839 Part 10) Degrees of severity 2 and 3 require an external protective circuit (see paragraph below) More stringent requirements to EN 298 regarding electromagnetic interference for modules which conform to this standard. | | |
| Asymmetrical connection | 1 kV (supply line) 1 kV (signal lead/data lead) 2 kV (supply line) | 2 |
| Symmetrical connection | 0.5 kV (supply line) | 3 |
| | 0.5 kV (signal lead/data lead) | 2 |
| | 1 kV (supply line) 1 kV (signal lead/data lead) | 3 |

Protecting the ET 200S with Fail-Safe Modules from Overvoltage

If your equipment makes protection from overvoltage necessary, we recommend that you use an external protective circuit (surge filter) between the load voltage power supply and the load voltage input of the terminal modules to ensure surge immunity for the ET 200S with fail-safe modules.

Note

Lightning protection measures always require a case-by-case examination of the entire system. Nearly complete protection from overvoltages, however, can only be achieved if the entire building surroundings have been designed for overvoltage protection. In particular, this involves structural measures in the building design phase.

Therefore, for detailed information regarding overvoltage protection, we recommend that you contact your Siemens representative or a company specializing in lightning protection.

The following figure illustrates an example configuration with F-modules and standard modules and the power modules PM-E DC24..48V/AC24..230V and PM-E F pm DC24V PROFIsafe. Voltage is supplied over four power supplies.

You can also use fewer power supplies. However, you must ensure that the total current of the modules fed by one power supply does not exceed the permissible limits.

You can also use power modules PM-E DC24V. The protective circuit corresponds to that of the PM-E DC24..48V/AC24..230V + automatic circuit breaker (as with PM-E F pm DC24V PROFIsafe).

For further information about surge protection for standard modules, see the *ET 200S Distributed I/O System* operating instructions.

Sinusoidal interference

HF radiation:

Tested in accordance with IEC 61000-4-3, "Radiated Electromagnetic Field Requirements"

- Standard test:
 - from 80 MHz through 1 GHz, tested at 10 V/m and 20 V/m; 80 % AM (1 kHz)
 - from 1.4 GHz through 2.7 GHz, tested at 10 V/m; 80 % AM (1 kHz)
- GSM/ISM/UMTS field interference of different frequencies (Standard: EN 298: 2004, IEC 61326-3-1)

Electromagnetic interference on signal and data lines:

Tested in accordance with IEC 61000-4-6, "Testing and measurement techniques – Immunity to conducted disturbances induced by radio-frequency fields"

- Standard test:
 - RF band, asymmetrical, amplitude modulated:
 - from 0.15 MHz through 80 MHz, tested at 10 V and 20 V rms; 80% AM (1 kHz)
- ISM interference of different frequencies (Standard: EN 298: 2004, IEC 61326-3-1)

Radio Interference Emission

Interference transmission of electromagnetic fields in accordance with EN 55011: Limit class A, group 1 (measured at a distance of 10 m).

| Frequency | Emitted Interference |
|------------------------------|-----------------------|
| Between 30 MHz and 230 MHz | < 40 dB (μ V/m)Q |
| Between 230 MHz and 1000 MHz | < 47 dB (μ V/m)Q |

Emitted interference by means of network-AC power supply in accordance with EN 55011: Limit class A, group 1.

| Frequency | Emitted Interference |
|------------------------------|--|
| Between 0.15 MHz and 0.5 MHz | < 79 dB (μ V)Q, < 66 dB (μ V)M |
| Between 0.5 MHz and 5 MHz | < 73 dB (μ V)Q, < 60 dB (μ V)M |
| Between 5 MHz and 30 MHz | < 73 dB (μ V)Q, < 60 dB (μ V)M |

6.4 Shipping and Storage Conditions

Requirements for Fail-Safe Modules

Fail-safe modules surpass the requirements for transport and storage conditions defined in IEC 61131, Part 2. The following specifications apply for fail-safe modules that are transported and stored in the original packaging.

| Type of Condition | Permissible Range |
|-----------------------|--|
| Free fall | ≤ 1 m |
| Temperature | From -40 °C to +70 °C |
| Temperature variation | 20 K/h |
| Air pressure | 1080 hPa to 660 hPa (corresponds to an altitude of -1000 m to 3500 m) |
| Relative humidity | 5% to 95%, no condensation |

6.5 Mechanical and Climatic Environmental Conditions

Conditions of Use

The F-modules are intended for use as stationary installations in sheltered locations. The conditions of use surpass the requirements in accordance with IEC 61131-2.

Fail-safe modules comply with conditions of use Class 3C3 in accordance with DIN EN 60721 3-3 (use in locations with heavy traffic and in the immediate vicinity of industrial systems with chemical emissions).

Restrictions

F-modules **cannot** be implemented without additional measures being taken:

- In locations with a high level of ionizing radiation
- In locations with severe operating conditions, due for example to:
 - Dust
 - Corrosive vapors or gases
- In systems which require special monitoring, such as:
 - Electrical systems in particularly hazardous areas

An additional measure for the implementation of fail-safe modules can be installing the ET 200S in cabinets, for example.

Mechanical Environmental Conditions

The table below shows the mechanical environmental conditions for F-modules in the form of sinusoidal oscillations.

| Frequency Range (Hz) | Continuous | Intermittent |
|----------------------|-----------------------------|-----------------------------|
| $10 \leq f \leq 58$ | Amplitude = 0.15 mm | Amplitude = 0.35 mm |
| $58 \leq f \leq 150$ | Constant acceleration = 2 g | Constant acceleration = 5 g |

Reduction of Vibration

If the F-modules are exposed to substantial shock or vibration, you must take appropriate measures to reduce the acceleration and amplitude.

We recommend that you mount the ET 200S on damping material (for example, on a rubber-metal vibration damper).

Testing of Mechanical Environmental Conditions

The table below provides information about the type and scope of testing of mechanical environmental conditions.

| Condition ... | Test Standard | Comments |
|------------------|--|--|
| Vibration | Vibration test in accordance with IEC 60068-2-6 (sinusoidal) | Type of vibration: Frequency cycles at a rate of change of 1 octave/minute. $10 \text{ Hz} \leq f \leq 58 \text{ Hz}$, constant amplitude 0.35 mm $58 \text{ Hz} \leq f \leq 150 \text{ Hz}$, constant acceleration 5 g Duration of vibration: 10 frequency cycles per axis at each one of the three perpendicular axes |
| Shock | Shock, tested in accordance with IEC 60068-2-27 | Shock type: Half-sine Shock severity: 15 g peak value, 11 ms duration Direction of shock: 3 shocks in +/- direction at each of the three perpendicular axes |
| Continuous shock | Shock, tested in accordance with IEC 60068-29 | Shock type: Half-sine Shock severity: 25 g peak value, 6 ms duration Direction of shock: 1000 shocks in +/- direction at each of the three perpendicular axes |

Climatic Environmental Conditions

ET 200S with fail-safe modules can be used under the following climatic environmental conditions:

| Environmental Conditions | Operating Range | Comments |
|--------------------------|--|--|
| Temperature | 0 °C to 60 °C | For horizontal installation |
| | 0 °C to 40 °C | For vertical installation |
| Temperature variation | 10 K/h | |
| Relative humidity | 15 % to 95 % | No condensation; corresponds to relative humidity (RH) stress level 2 in accordance with IEC 61131-2 |
| Air pressure | 1080 hPa to 795 hPa | Corresponds to an altitude of -1000 m to 2000 m |
| Pollutant concentration | SO ₂ : < 0.5 ppm; relative humidity < 60%, no condensation H ₂ S: < 0,1 ppm; relative humidity < 60%, no condensation | - |
| | ISA-S71.04 severity level G1; G2; G3 | - |

6.6 Specifications for Nominal Line Voltages, Isolation Tests, Protection Class, and Type of Protection

Rated Voltages for Operation

The fail-safe signal modules operate at a rated voltage of 24 VDC. The tolerance range is = 20.4 VDC to 28.8 VDC.

Test Voltages

Refer to the technical specifications of the fail-safe modules for information regarding the test voltages.

Protection Class

Protection class I in accordance with IEC 60536 (VDE 0106, Part 1), i.e. ground terminal required on DIN rail!

Type of Protection

Type of protection IP20 to EN 60529 for all F-modules, that is:

- Protection from contact with standard probes
- Protection from foreign bodies larger than 12.5 mm in diameter
- No special protection against water

See also

Safe Functional Extra-Low Voltage (SELV) for Fail-Safe Modules (Page 45)

Fail-Safe Modules

7.1 Introduction

This section

Fail-safe power modules and fail-safe digital modules are available for connecting digital sensors/encoders and actuators/loads to the ET 200S. This section provides the following information for each fail-safe module:

- Properties and special features
- Front view, terminal assignment for terminal modules and the block diagram
- Wiring diagram and programmable parameters
- Diagnostic functions, including corrective measures
- Technical specifications

| |
|--|
|  WARNING |
|--|

| |
|---|
| <p>The safety characteristics in the technical specifications apply for proof test intervals of 20 years and repair times of 100 hours. If a repair within 100 hours is not possible, then remove the respective module from the terminal module or switch off its supply voltage before 100 hours expires.</p> |
|---|

| |
|--|
| <p>Then proceed as described in the section "Reactions to Faults (Page 53)".</p> |
|--|

Passivation of fail-safe outputs over a long period of time

 **WARNING**

Unintentional activation of fail-safe I/O with fail-safe outputs

If a fail-safe I/O with fail-safe outputs is passivated for a period longer than that specified in the safety parameters (> 100 hours) and the error remains uncorrected, you need to exclude the possibility that the fail-safe I/O can be activated unintentionally by a second error, and thus place the fail-safe system in a dangerous state.

Although there is very low probability that such hardware errors will occur, unintentional activation of fail-safe I/O with fail-safe outputs must be prevented using circuitry or organizational measures.

One possibility is to switch off the power supply of the passivated fail-safe I/O, within a period of, for example, 100 hours.

In plants for which there are product standards, the required measures have been standardized.

In all other plants, the plant operator must create a design for the necessary measures and have them confirmed by the acceptance experts.

Bit pattern test / short-circuit test

The fail-safe P/M-switching PM-E F pm DC24V PROFIsafe and EM 4 F-DO DC24V/2A PROFIsafe regularly perform a bit pattern test to detect a short-circuit, short-circuit to ground or ground fault at an early stage.

For the fail-safe 4/8 F-DI DC24V PROFIsafe input modules, the sensor supply provided by the module and the cyclic short-circuit test can be used to detect short-circuit to the digital inputs, between the external sensor supplies and/or the 24V power supply or ground.

If an error is detected, the safety function is triggered thus avoiding unwanted and dangerous plant states.

You can find detailed information about the bit pattern test for the fail-safe ET 200S modules, the response of the employed modules and the available parameters on the Internet (<http://support.automation.siemens.com/WW/view/en/44452714>).

Description of Usable Standard Power Models and Terminal Modules

Usable standard power modules and terminal modules are described in the ET 200S distributed I/O system operating instructions.

7.2 PM-E F pm DC24V PROFIsafe Power Module

7.2.1 Properties of the PM-E F pm DC24V PROFIsafe Power Module

Order Number

6ES7138-4CF03-0AB0

Properties

The PM-E F pm DC24V PROFIsafe power module possesses the following properties:

- 2 relays for switching the voltage buses P1 and P2, output current = 10 A
- 2 fail-safe digital outputs, P/M-switching, output current 2 A
- Rated load voltage 24 VDC
- Suitable for solenoid valves, DC contactors and indicator lights
- Group fault display (SF; red LED)
- Status display for each output (green LED)
- Status display for load current power supply (PWR; green LED)
- Assignable diagnostics
- Achievable safety classes are listed in the table below

Note

The PM-E F pm DC24V PROFIsafe power module is not suitable for the supply of F-SMs.

Table 7- 1 Overview of available safety classes with PM-E F pm DC24V PROFIsafe

| PM-E F pm DC24V PROFIsafe | | Maximum Attainable Safety Class |
|----------------------------------|---|---------------------------------|
| Relay outputs P1 and P2 | Signal switches monthly or more often | SIL3/Category 4/PLe |
| | Signal switches less than once a month | SIL2/Category 3/PLd |
| Electronic outputs DO 0 and DO 1 | refer to the applications in the section "Wiring of the PM-E F pm DC24V PROFIsafe (Page 84)". | SIL3/Category 4/PLe |

Two Fail-Safe Digital Outputs

In addition to the voltage buses P1 and P2, the power module has two fail-safe digital outputs DO0 and DO1. You can achieve SIL3/Category 4/PLe with these outputs.

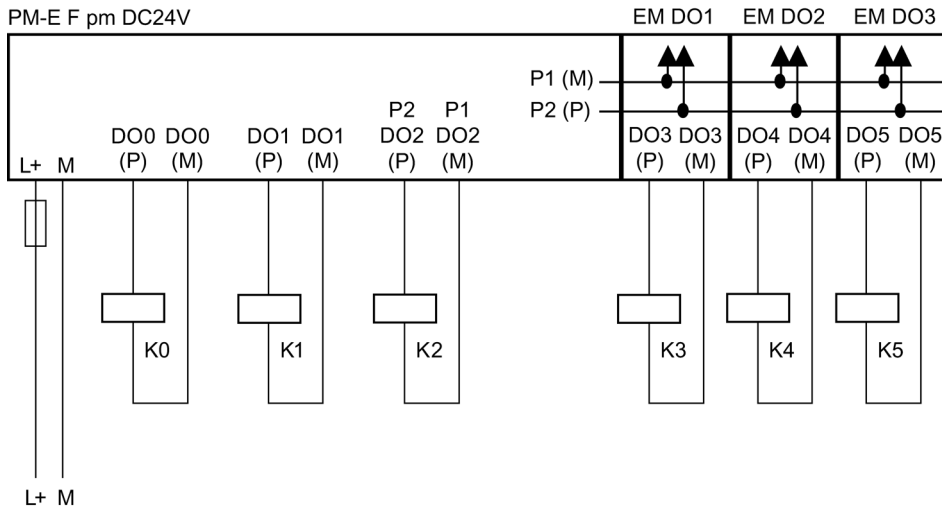





Figure 7-1 Wiring diagram of the PM-E F pm DC24V PROFIsafe

Power Module Supplies for Standard ET 200S Modules

| |
|--|
|  WARNING |
| <p>Always connect the 24 VDC supply for the standard ET 200S modules on the PM-E F pm DC24V PROFIsafe. Otherwise, the outputs of DO modules may exhibit safety critical behavior.</p> |
|  WARNING |
| <p>When supplying standard DO modules, always use the terminal modules to supply the actuators (actuator feedback on the DO module). Refer also to the section "Switching grounded loads".</p> |

Safety-Related Shutdown of Standard Output Modules

Refer to the Internet (<http://support.automation.siemens.com/WW/view/en/39198632>) for a list of all the released standard ET 200S modules.

| |
|--|
| <p> WARNING</p> <p>Safety-related activation of standard DO module outputs is not possible. Only safety-related shutdown is possible. The following issues must therefore be taken into consideration:</p> <p>In the worst case you must consider all possible faults of the standard DO modules and the programs controlling them for which the faults cannot be found directly. For example, the PM-E F pm DC24V PROFIsafe does not detect external short-circuits to L+ at the standard DO module outputs. All faults developing at the standard DO modules influence the process via final controlling elements. The process status must be made known to the F-CPU by way of sensors and a suitable safety program.</p> <p>Diagnostic functions must be handled indirectly in the controlled process since the self-test function of standard DO modules cannot be used to detect safety-critical faults: The safety control function does not intervene in the faulty process as long as hazards can be excluded. However, it shuts down the system if the process develops unwanted or potentially dangerous activities.</p> <p>Consequently, instead of the short fault reaction times defined in S7, the reaction time to internal faults in standard DO modules is determined by the controlled process and its corresponding feedback signals.</p> <p>Safety-related process values must be</p> <ul style="list-style-type: none"> • safely • read in by way of fail-safe input modules (e.g. F-DI), • prepared by the F-CPU for output commands and • output at the fail-safe output module for shutdown of the corresponding safety relay or • output at the fail-safe power module PM-E F. <p>If the process does not respond as expected due to malfunctions within a process or faulty standard DO modules, these standard DO modules must be set to safe state by way of the higher-level safety circuit.</p> <p>The process safety time is of particular importance here. Risks due to any malfunctions within the process control system can be ruled out within this process safety time.</p> <p>The safety program must react in a safety-related and logically suitable fashion to unwanted or potentially dangerous states in the process via the PM-E F pm DC24V PROFIsafe and fail-safe output modules.</p> |
|--|

If you want to completely avoid the problems described above, we recommend you use P/M-switching fail-safe electronic module 4 F-DO DC24V/2A PROFIsafe with standard ET 200S power modules (see *"Digital electronic module 4 F-DO DC24V/2A PROFIsafe"* and the table *"Assigning power modules to electronic modules / motor starters and safety class"*).

Property of safety-related tripping of standard DO modules with the PM-E F pm DC24V PROFIsafe:

This cost-effective solution allows the full and simultaneous shutdown of all outputs involved when a fault is detected in the process or on the PM-E F pm DC24V PROFIsafe.

Property of the individual shutdown of F-modules with fail-safe outputs:

The scope of shutdown is kept to a minimum when a fault is detected. It is also possible to react to critical process states staggered over time, or to perform safety-related shutdown of individual outputs.

Switching Grounded Loads

If the PM-E F pm DC24V PROFIsafe switches loads that have a chassis-ground connection (for example to improve EMC characteristics) **and** if chassis and ground are connected at the power supply being used, a "short-circuit" is detected.

From the perspective of the F-module, the M-switch is bridged by the chassis-ground connection (refer to the diagram below as an example of an PM-E F pm DC24V PROFIsafe).

For the PM-E F pm DC24V PROFIsafe, as of Order No. 6ES7138-4CF02-0AB0, release version 02, the resistance to capacitive loads between the M switch and chassis was increased from approx. 1 μ F to around 20 μ F.

Remedy:

- Using the PM-E F pp DC24V PROFIsafe
- The value of the resistance between chassis and ground at the load end must be greater than 100 k Ω
- The capacity value at the load end between chassis and ground must be less than 20 μ F.

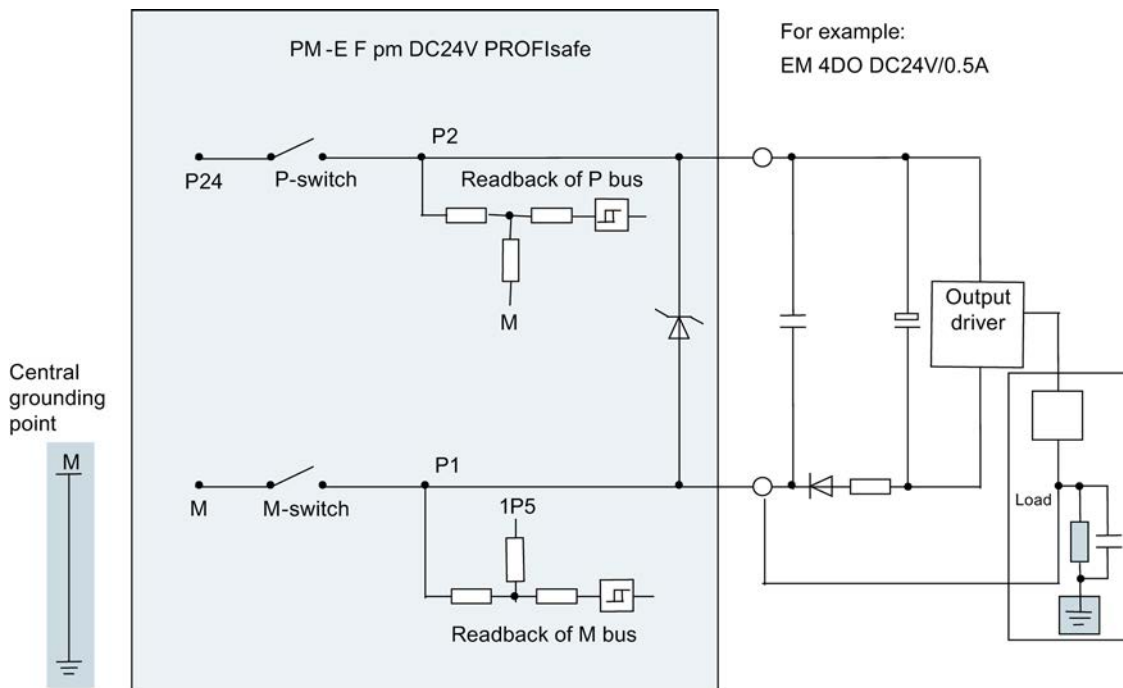

Figure 7-2 Switching Grounded Loads (resistance exists between chassis and ground)

⚠ WARNING

During startup, the PM-E F pm DC24V PROFIsafe carries out a power on self-test that takes around 3 ms. The load capacitance between chassis and ground is charged by way of the load resistance. This low charging current may briefly trigger sensitive load circuits.

Capacitive Crosstalk of Digital Input/Output Signals

Readback errors may occur on the PM-E F pm DC24V PROFIsafe power module or on the F-DO modules if the fail-safe digital output and fail-safe digital input signals are routed through one cable. The module signals a short-circuit in this situation.

Cause

The steep switching edge of the output driver during the sensor supply test of the 4/8 F-DI DC24V PROFIsafe module may lead to crosstalk on other inactive output channels due to the coupling capacitance of the wire, for example, on the PM-E F pm DC24V PROFIsafe power module. This situation may lead to a response in the readback circuit in these channels. The module detects a cross circuit and performs safety-related shutdown.

Remedy

- Use separate cables for the F-DI modules and F-DO modules or standard DO modules that are controlled by a PM-E F pm DC24V PROFIsafe.
- Coupling relay or diodes in the outputs
- Disable the sensor supply test if safety class requirements allow this.

See also

Assigning ET 200S modules (Page 26)

Properties of the 4 F-DO DC24V/2A PROFIsafe Digital Electronic Module (Page 186)

7.2.2 Terminal assignment of the PM-E F pm DC24V PROFIsafe

Incoming 24 VDC supply to Electronic Modules with Technology Functions

Depending on whether the electronic and load current supplies are electrically isolated in the electronic modules with technology functions (positioning, counting), you must comply with the following wiring rules:

- If electrically isolated, you can connect the electronic module to an external 24 VDC power supply.
- If not electrically isolated, you must supply the electronic module from voltage bus P1 and P2 of the PM-E F pm DC24V PROFIsafe.

SIL2/Category 3/PLd is attainable in both cases.

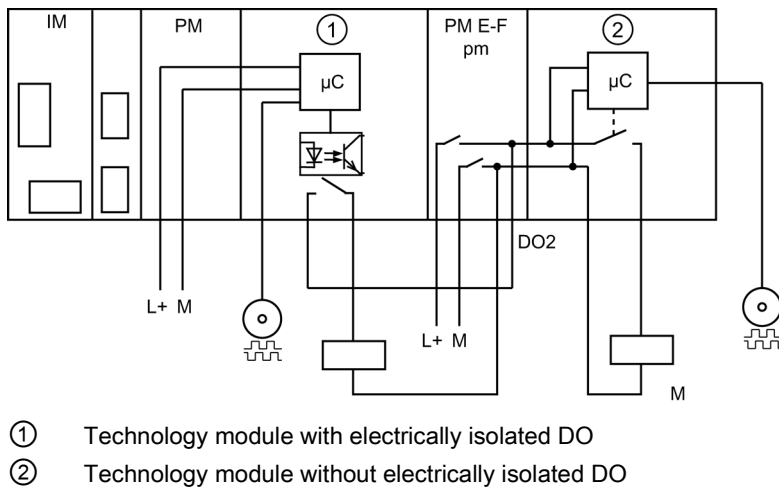

Front View

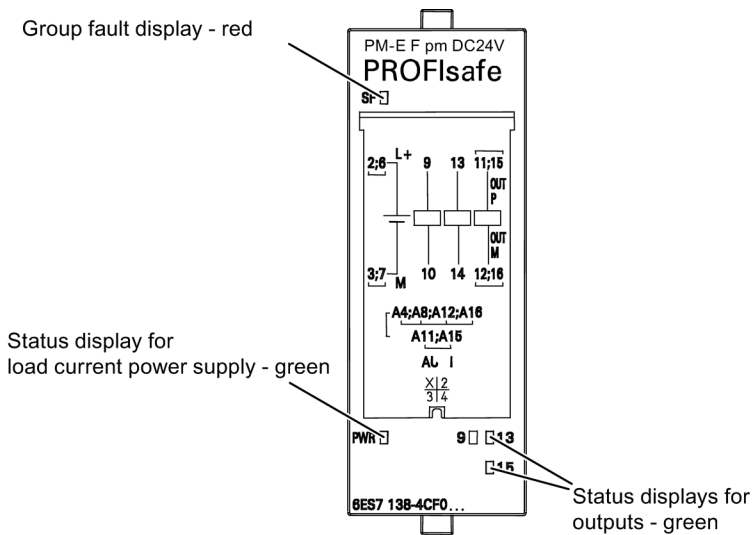

Figure 7-3 Front view PM-E F pm DC24V PROFIsafe

| | |
|---|-----------------------|
| | <p>WARNING</p> |
| <p>The SF LED and the status displays of the inputs/outputs are not designed for safety-related functions and may therefore not be evaluated for safety-related activities.</p> | |

Terminal Assignment

The following figure and the following table show the terminal assignment of the PM-E F pm DC 24V PROFIsafe for the supported terminal modules TM-P30S44-A0 or TM-P30C44-A0.

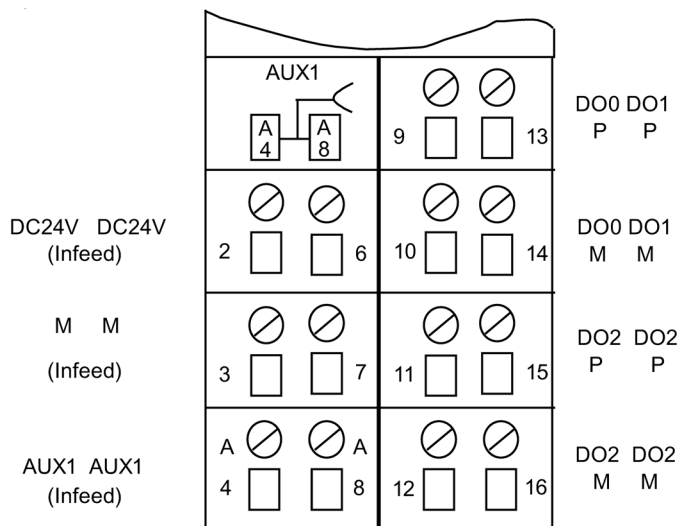

Figure 7-4 Terminal assignment TM-P30S44-A0 or TM-P30C44-A0 for PM-E F pm DC 24V PROFIsafe

Table 7- 2 Terminal assignment of the TM-P30S44-A0 or TM-P30C44-A0

| Terminal | Designation | Designation |
|----------|-------------|---|
| 2 | 24 VDC | 24 VDC rated load voltage for: <ul style="list-style-type: none"> • Inserted power module • Corresponding potential group • DO 0 and DO 1 • Voltage buses P1 and P2 |
| 3 | M | Ground |
| A 4 | AUX 1 | Any terminal for PE or voltage bus up to the maximum rated load voltage of the module |
| 6 | 24 VDC | 24 VDC rated load voltage for: <ul style="list-style-type: none"> • Inserted power module • Corresponding potential group • DO 0 and DO 1 • Voltage buses P1 and P2 |
| 7 | M | Ground |
| A 8 | AUX 1 | Any terminal for PE or voltage bus up to the maximum rated load voltage of the module |
| 9 | DO 0 P | Terminals for fail-safe digital output 0 (P/M-switching) |
| 10 | DO 0 M | |
| 11 | DO 2 P | Terminals (relay contacts) for fail-safe switching of voltage buses P1 and P2 |

| Terminal | Designation | Description |
|----------|-------------|--|
| 12 | DO 2 M | P1 and P2 can also be used as DO 2 M and DO 2 P |
| 13 | DO 1 P | Terminals for fail-safe digital output 1 (P/M-switching) |
| 14 | DO 1 M | |
| 15 | DO 2 P | Terminals (relay contacts) for fail-safe switching of the voltage buses P1 and P2 P1 and P2 can also be used as DO 2 M and DO 2 P |
| 16 | DO 2 M | |

CAUTION

If high currents can occur on DO 2 P and DO 2 M, you must wire terminals 11 and 15 (DO 2 P) and 12 and 16 (DO 2 M) in parallel.

Otherwise, high current loads may cause the terminals to heat up.

7.2.3 Wiring of the PM-E F pm DC24V PROFIsafe

Block Diagram

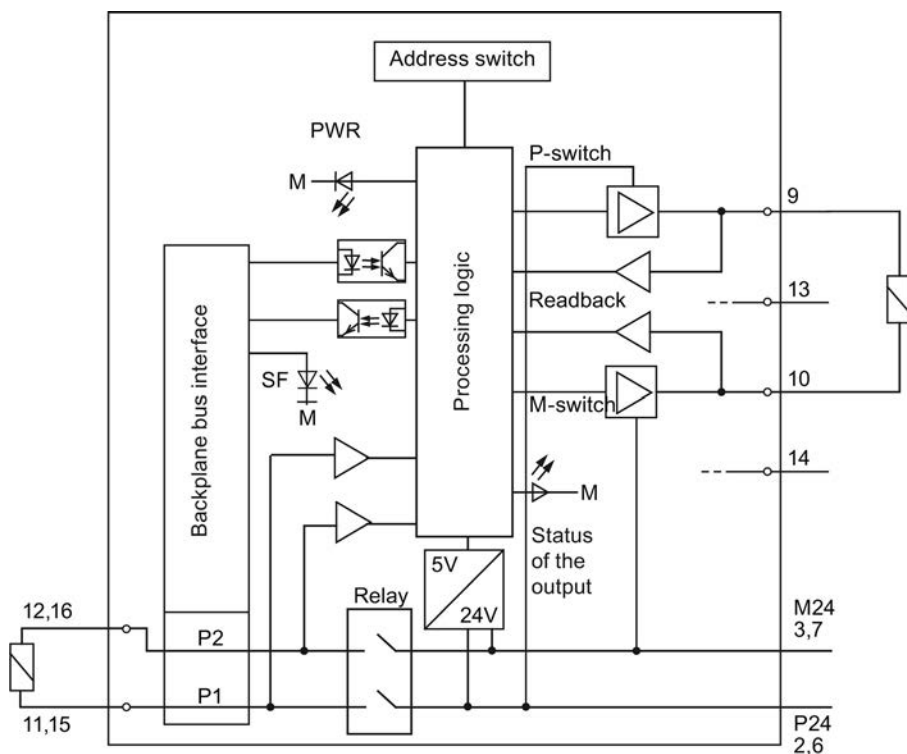

Figure 7-5 Block diagram of the PM-E F pm DC24V PROFIsafe

Application 1: Wiring a load to each digital output

Each of the three digital outputs consists of a DOx P P-switch and a DOx M M-switch. You connect the load between the P and M-switches. The two switches are always activated so that voltage is applied to the load.

Wire the PM using the special terminal module.

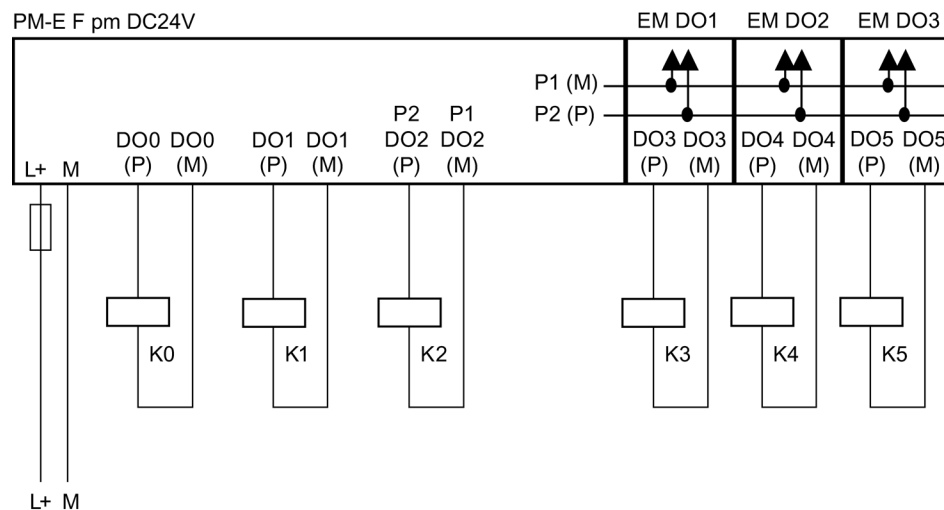

Figure 7-6 Wiring diagram of the PM-E F pm DC24V PROFIsafe

Note

In order to achieve SIL3/Category 4/PLe with this wiring, you must install a suitably-qualified sensor, for example in accordance with IEC 60947.

WARNING

Please always use an external fuse for L+ at the PM-E F pm with the following properties to protect the relay contacts from overload: Circuit-breaker, characteristics B, 10 A.

Relay Output DO 2

The relay output DO 2 connects the voltage L+ and M using one relay contact for each. The voltage is fed outwards to the terminal module and to the internal voltage buses P1 and P2. This results in two connection options that can also be used at the same time if desired:

- A load can be connected directly to the terminal module (K2 in the figure above)
- Electronic modules can be supplied by means of the internal voltage buses P1 and P2. Loads can be connected to these modules in turn (K3, K4, K5 in the figure above)

Application 2: Wiring loads to L+ and M at each digital output

You can connect two relays using one fail-safe digital output. The following conditions should be kept in mind:

- L+ and M of the relays must be connected with L+ and M of the PM-E F pm (reference potential must be equal).
- The normally open contacts of the two relays must be connected in series.

This connection can only be made on digital outputs DO 0 and DO 1 (not DO 2). With this circuit, you achieve:

- SIL3/Category 4/PLe

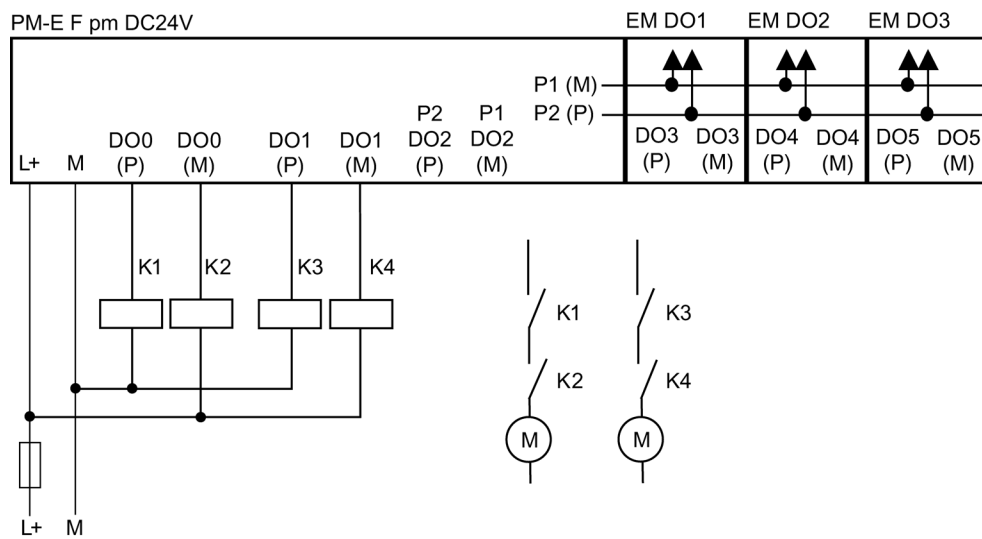

Figure 7-7 Wiring diagram for each of two relays on DO 0 and DO 1 of the PM-E F pm DC24V PROFIsafe

⚠ WARNING

The F module has a failsafe response, even in the overvoltage range of 28.8 V to 44 V DC.

If this range is guaranteed by the selection of the power supply unit, no special measures are required. For more on this, refer to the information in the data sheet on overvoltage protection in the case of an internal error. If this range is not guaranteed, voltage-limiting measures are required, for example, the use of a surge protection device.

⚠ WARNING

When connecting two relays on one digital output (as shown in the figure above), the errors "wire break" and "overload" are detected only at the P-switch of the output (not at the M-switch).

⚠ WARNING

The controlled actuator can no longer be switched off when there is a cross circuit between the P and M-switches of the output. To avoid cross circuits between the P and M-switches of a fail-safe digital output, you should always wire the relay connection to the P and M-switches separately, in order to prevent any cross-circuits (for example with separately-sheathed cables or using separate cable ducts).

Note

The PM-E F pm DC24V PROFIsafe carries out a bit pattern test every 15 minutes or so. The module then sends an impulse for max. 4 ms. This test is executed deferred between P and M-switches, so that the actuator is not switched on. This impulse may cause the corresponding relay to tighten, which may reduce its service life.

We therefore recommend adhering to the wiring scheme detailed below.

Application 3: Wiring two loads in parallel to each digital output

Avoiding / Managing Cross Circuits:

To protect against cross circuits between P and M-switches in fail-safe digital outputs, we recommend the following wiring scheme:

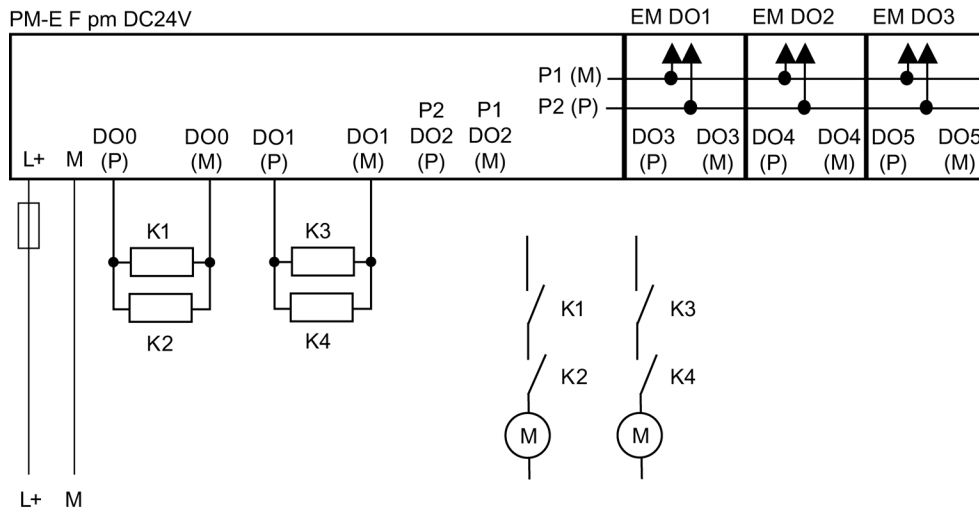

Figure 7-8 Wiring diagram for each of two relays parallel on DO 0 and DO 1 of the PM-E F pm DC24V PROFIsafe

Note

With parallel connection of two relays to one digital output (as shown above), the "wire break" fault is only detected if the wire break disconnects both relays from P or M. This diagnosis is not safety-related.

7.2.4 Parameters of the PM-E F pm 24 VDC PROFIsafe

Parameters in *STEP 7*

The table below lists the parameters that can be set for the PM-E F pm DC24V PROFIsafe.

Table 7- 3 Parameters of the PM-E F pm DC24V PROFIsafe

| Parameter | Range | Default | Type of Parameter | Effective Range |
|---|---|---------------------------------|-------------------|-----------------|
| F-Parameters: | | | | |
| F_destination_address | 1 to 1022 | is assigned by <i>STEP 7</i> | Static | Module |
| F monitoring time | 10 to 10 000 ms | 150 ms | Static | Module |
| Module Parameters: | | | | |
| Behavior after channel faults* | Passivate the entire module/Passivate the channel | Passivate the entire module | Static | Module |
| DO channel 0 | Activated/deactivated | Activated | Static | Channel |
| Readback time | 1 to 400 ms | 1 ms | Static | Channel |
| Diagnostics: Wire break | Activated/deactivated | Deactivated | Static | Channel |
| DO channel 1 | Activated/deactivated | Activated | Static | Channel |
| Readback time | 1 to 400 ms | 1 ms | Static | Channel |
| Diagnostics: Wire break | Activated/deactivated | Deactivated | Static | Channel |
| * This setting is relevant only with an installed <i>S7 distributed safety</i> V 5.4 or higher or generally with <i>S7 F systems</i> optional packages. | | | | |

Readback Time Parameter

Each output channel has its own selectable readback time. This time specifies the maximum duration of the turn off test for the corresponding channel and therefore also the readback time for turning off the channel.

The following readback times can be set: 1 ms, 5 ms, 10 ms, 50 ms, 100 ms, 200 ms and 400 ms.

You should set an adequately high readback time if the channel involved switches high capacitive loads. If the readback time for a controlled capacitive load is set too low, the output channel is passivated because the discharge of the capacitance does not take place within the turn off test.

If the readback signals are incorrect, the "short-circuit" fault only causes passivation of the output channel after the readback time has elapsed.

Note

Note that an inductive load connected to the DO channels can induce voltages in the case of electromagnetic interference of a strong magnetic field. This can cause a short-circuit error message.

Remedy:

- Spatially disconnect the inductive loads or shield against the magnetic field.
- Set the parameters for the readback time to 50 ms or higher.

| |
|--|
|  WARNING |
|--|

| |
|---|
| With a configured readback time of ≥ 50 ms, short-circuits (cross-circuits) can be suppressed with an interference signal with a frequency > 10 Hz (50:50 duty cycle). |
|---|

| |
|---|
| Short-circuits (cross circuits) on an output of the same module will be detected. |
|---|

Effects of parameter changes on the bit pattern test

The duration of a test pulse in the dark test depends on the load and is less than or equal to the configured readback time.

You can find detailed information about the bit pattern test for the fail-safe ET 200S modules, the response of the employed modules and the available parameters on the Internet (<http://support.automation.siemens.com/WW/view/en/44452714>).

7.2.5 Diagnostic Functions of the PM-E F pm DC24V PROFIsafe

Behavior in Case of Supply Voltage Failure

The failure of the PM-E F pm DC24V PROFIsafe power supply is always indicated by the PWR LED on the module (light off). This information is also provided in the module (diagnostic entry). Either all channels of the module are passivated or, in the case of channel-specific passivation, the relevant channels are passivated.

In the case of a voltage dip in the external auxiliary voltage, the SF LED lights up, the module is passivated.

With the subsequent supply recovery (level must remain above the specified value for at least 1 minute (refer to the technical specifications: voltages, currents, electrical potentials)) the SF LED goes out again, the module remains passivated. The SF LED flashes if there are no other errors, until the error is acknowledged.

Diagnostic functions

The table below provides an overview of the diagnostic functions of the PM-E F pm DC24V PROFIsafe. The diagnostic functions are assigned either to one channel or to the entire module.

Table 7- 4 Diagnostic functions of the PM-E F pm DC24V PROFIsafe

| Diagnostic Function* | Fault Number | LED | Effective Range of Diagnostics | Can be Assigned Parameters |
|--|-----------------|-----|--------------------------------|----------------------------|
| Short-circuit | 1 _H | SF | Channel | No |
| Overload | 4 _H | SF | Channel | No |
| Overtemperature | 5 _H | SF | Module | No |
| Wire break | 6 _H | SF | Channel | Yes |
| Internal error | 9 _H | SF | Module | No |
| Parameter assignment error | 10 _H | SF | Module | No |
| Sensor voltage or load voltage missing | 11 _H | SF | Module | No |
| Communication error | 13 _H | SF | Module | No |
| Safety-related shutdown | 19 _H | SF | Channel | No |

*: Specially for F-modules; display in *STEP 7*, see "Channel-Specific Diagnostics, Fault Types of Fail-Safe Modules" table

| |
|---|
|  WARNING |
| Before acknowledging the short-circuit diagnosis, remedy the respective error and validate your safety function. To do this, proceed as described in section "Fault Diagnostics (Page 55)". |

Causes of Faults and Corrective Measures

The following table contains the possible causes of the faults described for the individual diagnostic messages of the PM-E F pm DC24V PROFIsafe and remedies.

Table 7- 5 Diagnostic messages of the PM-E F pm DC24V PROFIsafe, causes of errors and remedies

| Diagnostic Message | Fault Detection | Possible Causes | Corrective Measures |
|--|----------------------------|--|--|
| Short-circuit | Always | Short-circuit in the actuator | Eliminate the short-circuit. |
| | | Cross circuit in the actuator | Eliminate the cross-circuit within 100 hours after the error has occurred. |
| | | Internal error | Replace module |
| | | Short-circuit in P1 and P2 because actuators connected to standard DO modules are not supplied by means of the terminal modules of the standard DO modules | Actuators connected to standard DO modules are supplied via the terminal module of the standard DO module; replace the fuse after a short-circuit Acknowledge the error within 100 hours after the error has occurred |
| Overload | For output signal "1" only | Output stage is overloaded and becomes too hot | Eliminate overload |
| Overtemperature | Always | Shutdown due to violation of upper or lower temperature limit value in the module case | Check load wiring, check ambient temperature, check whether permissible output current is exceeded for the ambient temperature. Once the fault has been eliminated, the module must be removed and inserted, or the power switched OFF and ON. |
| Wire break | For output signal "1" only | Wire break | Eliminate broken wire, ensure specified minimum load (see Technical Specifications) |
| Internal error | Always | Internal module fault has occurred | Replace module |
| Parameter assignment error | Always | Inserted module does not match configuration; incorrect parameter assignment | Correct the configuration (compare actual and preset configuration). Check communication paths. Correct parameter assignment |
| | | PROFIsafe address set incorrectly in the F-module | Check whether the PROFIsafe address on the module matches the configuration in <i>HW Config</i> |
| Sensor voltage or load voltage missing | Always | Supply voltage not available or too low (e.g. voltage dip on F-module, this can also be caused, among other things, by a short-circuit on the P1/P2 buses. | Check module for correct contact |

| Diagnostic Message | Fault Detection | Possible Causes | Corrective Measures |
|-------------------------|-----------------|---|--|
| Communication error | Always | Error in communication between F-CPU and module, e.g. due to defective PROFIBUS connection or higher than permissible EMI | Check the PROFIBUS/PROFINET connection Eliminate the interference |
| | | PROFIsafe monitoring time set too low | Set a greater value for the "F monitoring time" parameter for the module in <i>HW Config</i> |
| | | Configuration of the F-module does not match safety program | Generate safety program again; then load configuration and safety program into F-CPU again |
| Safety-related shutdown | Always | Switching frequency exceeded | Reduce the switching frequency or use a semiconductor output |

Generally Applicable Information on Diagnostics

For information on diagnostics that pertains to all fail-safe modules (e.g. for reading out diagnostic functions, passivating channels), refer to the "*Diagnostics*" section in this manual.

See also

Reactions to Faults (Page 53)

7.2.6 Technical Specifications of PM-E F pm DC24V PROFIsafe

Overview

| Technical specifications | |
|---|--------------|
| Dimensions and weight | |
| Dimensions W x H x D (mm) | 30 x 81 x 52 |
| Weight | Approx. 88 g |
| Data for Specific Module | |
| Number of outputs | |
| • Semiconductor outputs (P/M switching) | 2 |
| • Relay outputs (P/M switching) | 1 |
| Assigned address area | |
| • In the I/O area for inputs | 5 bytes |
| • In the I/O area for outputs | 5 bytes |

| Technical specifications | |
|---|--|
| Length of cable* | |
| • Unshielded | 200 m, maximum |
| • Shielded | 200 m, maximum |
| Maximum achievable safety class | |
| • in accordance with IEC 61508:2000, ISO 13849-1:2006 or EN ISO 13849-1:2008 | Max. SIL3, Cat.4/PLe (for conditions see "Power module PM-E F pm DC24V PROFIsafe") |
| Safety characteristics | SIL3 |
| • Low demand mode (average probability of failure on demand) | < 1.00E-05 |
| • High demand/continuous mode (probability of a dangerous failure per hour) | < 1.00E-10 |
| • Acceptance ID | FM, cULus, CE, C-Tick |
| Voltages, Currents, Potentials | |
| Rated supply voltage L+ | 24 VDC |
| • permissible range ** | 20.4 V to 28.8 V |
| • Power loss ride-through of L+ | None |
| • Power loss ride-through of internal P5 | 5 ms |
| • Reverse polarity protection | No |
| Total current | |
| • Horizontal installation <ul style="list-style-type: none"> – Up to 40 °C – Up to 55 °C – Up to 60 °C | 10 A 7 A 6 A |
| • Vertical installation <ul style="list-style-type: none"> – Up to 40 °C | 6 A |
| Electrical isolation | |
| • Between channels and backplane bus | Yes |
| • Between channels and power supply | No |
| • Between channels | No |
| • Between channels/power supply and shield | Yes |
| Permissible potential difference between | |
| • Shield and ET 200S bus connection | 75 V DC/60 V AC |
| • Shield and I/O (DOs, P1/P2 buses) | 75 V DC/60 V AC |
| • ET 200S bus connection and I/O (DOs, P1/P2 buses) | 250 V AC |
| Isolation in the series tested with | |
| • ET 200S bus connection against I/O (DOs, P1/P2 buses) | 2545 V DC/2 s |

| Technical specifications | |
|--|--|
| Isolation in the type test tested with | |
| • Shield and ET 200S bus connection | 350 V AC/1 min |
| • Shield and I/O (DOs, P1/P2 buses) | 350 V AC/1 min |
| • ET 200S bus connection and I/O (DOs, P1/P2 buses) | 2830 V AC/1 min |
| • Surge voltage test between ET 200S bus connection and I/O (DOs, P1/P2 buses) | 6000 V DC/5 positive and 5 negative pulses |
| Current consumption | |
| • From backplane bus | 28 mA, maximum |
| • From load voltage L+ (without load) | 100 mA, typical |
| Power loss of the module | 4 W, typical |
| Status, interrupts, diagnostics | |
| Status display | <ul style="list-style-type: none"> • Green LED per channel • Green LED for the load voltage |
| Diagnostic functions | |
| • Group fault display | Red LED (SF) |
| • Diagnostic information can be displayed | Possible |
| Data for selecting an actuator for the semiconductor outputs*** | |
| Output voltage | |
| • For "1" signal | <ul style="list-style-type: none"> • Minimum L+ (-2.0 V) • P-switch: minimum L+ (-1.5 V), voltage drop in M-switch: Maximum, 0.5 V |
| Output current for "1" signal | |
| • Rated value | 2 A |
| • Permissible range | 20 mA to 2.4 A |
| For "0" signal (residual current) | 0.5 mA, maximum |
| Indirect control of load by means of interface relay: | |
| Residual current for "0" signal | |
| • P-switch | 0.5 mA, maximum |
| • M-switch | 4 mA, maximum |
| Load resistance range | 12 Ω to 1 k Ω |
| Lamp load | 10 W, maximum |
| Wire break monitoring (open load detection) and overload monitoring | |
| • Response threshold | I < 4 to 19 mA |
| • Fault detection time | depending on the selected readback time (see "Response times") |

| Technical specifications | | |
|--|-----------------------------|-----------------------------------|
| Parallel connection of 2 outputs | Not possible | |
| Control of a digital input | Not possible | |
| Switching frequency | | |
| • With resistive load | 30 Hz symmetrical, maximum | |
| • With inductive load in accordance with IEC 60947-5-1, DC13 | 0.1 Hz symmetrical, maximum | |
| • With lamp load | 10 Hz symmetrical, maximum | |
| Voltage induced on current interruption limited to | | |
| • Semiconductor outputs | L+ (-2x 47 V) | |
| • Relay outputs | P1/P2 (1 V) | |
| Short-circuit protection of semiconductor outputs | Yes, electronic | |
| • Response threshold of short-circuit | 5 A to 12 A | |
| • Response threshold (external M-short-circuit) | 5 A to 12 A | |
| • Response threshold (external P-short-circuit) | 25 A to 45 A | |
| Overload protection of semiconductor outputs | Yes | |
| • Response threshold | I >2.6 A to 2.8 A | |
| Data for selecting an actuator for the relay outputs*** | | |
| Switching capacity and service life of contacts (voltage 24 VDC) | | |
| • Mechanical endurance (without load) | Current | Number of switching cycles (typ.) |
| | 0 A | 10 million |
| • For resistive load | Current | Number of switching cycles (typ.) |
| | 10 A | 0.23 million |
| | 8 A | 0.3 million |
| | 6 A | 0.38 million |
| | 4 A | 0.5 million |
| | 2 A | 1.0 million |
| | 1 A | 2.0 million |
| • For inductive load in accordance with IEC 60947-5-1, DC13 | Current | Number of switching cycles (typ.) |
| | 10 A | 0.1 million |
| | 8 A | 0.15 million |
| | 6 A | 0.2 million |
| | 4 A | 0.3 million |
| | 2 A | 0.5 million |
| | 1 A | 1.0 million |
| • For lamp load | Power | Number of switching cycles (typ.) |
| | 100 W | 0.12 million |

| Technical specifications | |
|--|---|
| Contact protection (internal) | Internal readback circuit |
| <ul style="list-style-type: none"> Between P and M relay output | 39 V suppressor diode |
| Wire break monitoring | No |
| Parallel connection of 2 outputs | Not possible |
| Control of a digital input | Not possible |
| Switching frequency | |
| <ul style="list-style-type: none"> With resistive load | 2 Hz, maximum |
| <ul style="list-style-type: none"> With inductive load in accordance with IEC 60947-5-1, DC13 | 0.1 Hz, maximum |
| <ul style="list-style-type: none"> With lamp load | 2 Hz, maximum |
| Short-circuit protection of output | No, 10 A external circuit-breaker, "B" characteristics required |
| Time, Frequency | |
| Internal processing times | See "Response times" |
| Acknowledgment time in safety mode | 4 ms minimum/8 ms maximum |
| Protection against overvoltage | |
| Protection of power supply L+ from surge in accordance with IEC 61000-4-5 with external protection elements only | |
| <ul style="list-style-type: none"> Symmetrical (L+ to M) | + 1 kV; 1.2/50 μ s |
| <ul style="list-style-type: none"> Asymmetrical (L+ to PE, M to PE) | + 2 kV; 1.2/50 μ s |
| Protection of outputs from surge in accordance with IEC 61000-4-5 with external protection elements only | |
| Symmetrical (DO to M) | + 1 kV; 1.2/50 μ s |
| Asymmetrical (DO to PE, M to PE) | + 1 kV; 1.2/50 μ s |
| *: In order to achieve the specified cable length, you must route the P and M-signal lines in a cable or a sheathed cable. | |
| **: Operating below the permissible supply voltage is only permissible for the repair time. See section "Introduction (Page 75)". | |
| Operating above the permissible supply voltage: At a supply voltage > 35.5 V, the fuse blows and the output drivers are disabled. | |
| ***: For more information on the requirements for encoders and actuators, refer to the section "Wiring and Fitting Modules (Page 45)". | |

7.3 PM-E F pp DC24V PROFIsafe power module

7.3.1 Properties of the PM-E F pp DC24V PROFIsafe Power Module

Order Number

6ES7138-4CF42-0AB0

Properties

The PM-E F pp DC24V PROFIsafe power module possesses the following properties:

- Two relays for connecting voltage bus P2, 10 A output current
- Relay contacts must be fused externally
- Rated load voltage 24 VDC
- Suitable for solenoid valves, DC contactors and indicator lights
- Suitable for applications in which a grounded configuration is specified or where an ungrounded configuration cannot be guaranteed
- Group fault display (SF; red LED)
- Status display for voltage bus P2 (green LED)
- Status display for load current power supply (PWR; green LED)
- Assignable diagnostics
- Achievable safety classes are listed in the table below

Table 7- 6 Overview of available safety classes with PM-E F pp DC24V PROFIsafe

| PM-E F pp DC24V PROFIsafe | | Maximum Attainable Safety Class |
|---------------------------|--|---------------------------------|
| Relay outputs P1 and P2 | Signal switches monthly or more often | SIL3/Category 4/PLe |
| | Signal switches less than once a month | SIL2/Category 3/PLd |

Interface modules that can be used

Refer to section "Using fail-safe ET 200S modules (Page 16)" for the supported interface modules.

Switching the P2 Voltage Bus

The power module is capable of fail-safe switching the P2 voltage bus by means of two series-connected relay contacts in accordance with SIL2/Category 3/PLd or SIL3/Category 4/PLe. P2 is available as P on the terminal module, and P1 as M.

Power Module Supplies for Standard ET 200S Modules

 WARNING

Always connect the 24 VDC supply for the standard ET 200S modules on the PM-E F pp DC24V PROFIsafe. Otherwise, the outputs of DO modules may exhibit safety critical behavior.

 WARNING

When supplying standard DO modules, always use the terminal modules to supply the actuators (actuator feedback on the DO module).

Redundant ground conductor required

 WARNING

The ground conductor to the terminal module for PM-E F pp DC24V PROFIsafe must be installed twice for safety reasons. Any interruption of a single ground conductor would prevent the safety-related shutdown of voltage bus P2.

Safety-Related Shutdown of Standard Output Modules

Refer to the Internet (<http://support.automation.siemens.com/WW/view/en/39198632>) for a list of all the released standard ET 200S modules.

 **WARNING**

Safety-related activation of standard DO module outputs is not possible. Only safety-related **shutdown** is possible. The following issues must therefore be taken into consideration:

In the worst case you must consider all possible faults of the standard DO modules and the programs controlling them for which the faults cannot be found directly. For example, the PM-E F pp DC24V PROFIsafe does not detect external short-circuits to L+ at the standard DO module outputs. All faults developing at the standard DO modules influence the process via final controlling elements. The process status must be made known to the F-CPU by way of sensors and a suitable safety program.

Diagnostic functions must be handled indirectly in the controlled process since the self-test function of standard DO modules cannot be used to detect safety-critical faults: The safety control function does not intervene in the faulty process as long as hazards can be excluded. However, it shuts down the system if the process develops unwanted or potentially dangerous activities.

Consequently, instead of the short fault reaction times defined in S7, the reaction time to internal faults in standard DO modules is determined by the controlled process and its corresponding feedback signals.

Safety-related process values must be

- safely
- read in by way of fail-safe input modules (e.g. F-DI),
- prepared by the F-CPU for output commands and
- output at the fail-safe output module for shutdown of the corresponding safety relay or
- output at the fail-safe power module PM-E F.

If the process does not respond as expected due to malfunctions within a process or faulty standard DO modules, these standard DO modules must be set to safe state by way of the higher-level safety circuit.

The process safety time is of particular importance here. Risks due to any malfunctions within the process control system can be ruled out within this process safety time.

The safety program must react in a safety-related and logically suitable fashion to unwanted or potentially dangerous states in the process via the PM-E F pp DC24V PROFIsafe and fail-safe output modules.

If you want to avoid the problems described above completely, we recommend that you use P/M switching fail-safe electronic modules 4 F-DO DC24V/2A PROFIsafe with standard ET 200S power modules instead of standard DO modules.

Properties of safety-related shutdown of standard DO modules with the PM-E F pp DC24V PROFIsafe:

This cost-effective solution allows the full and simultaneous shutdown of all outputs involved when a fault is detected in the process or on the PM-E F pp DC24V PROFIsafe.

Property of the individual shutdown of F-modules with fail-safe outputs:

The scope of shutdown is kept to a minimum when a fault is detected. It is also possible to react to critical process states staggered over time, or to perform safety-related shutdown of individual outputs. Compared to the safety-related shutdown by the PM-E F pp DC24V PROFIsafe, this solution costs more.

See also

Assigning ET 200S modules (Page 26)

Properties of the 4 F-DO DC24V/2A PROFIsafe Digital Electronic Module (Page 186)

7.3.2 Terminal assignment of the PM-E F pp DC24V PROFIsafe**Incoming 24 VDC supply to Electronic Modules with Technology Functions**

Depending on whether the electronic and load current supplies are electrically isolated in the electronic modules with technology functions (positioning, counting), you must comply with the following wiring rules:

- If electrically isolated, you can connect the electronic module to an external 24 VDC power supply.
- if not electrically isolated, you must supply the electronic module from the voltage bus P2 of the PM-E F pp DC24V PROFIsafe.

SIL2/Category 3/PLd is attainable in both cases.

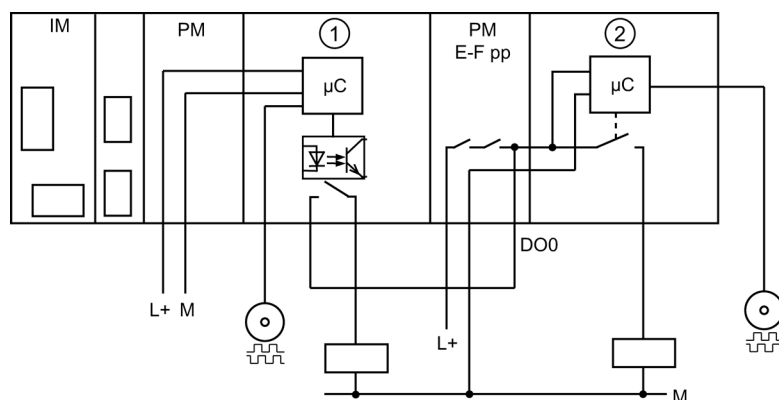

- ① Technology module with electrically isolated DO
- ② Technology module without electrically isolated DO

Front View

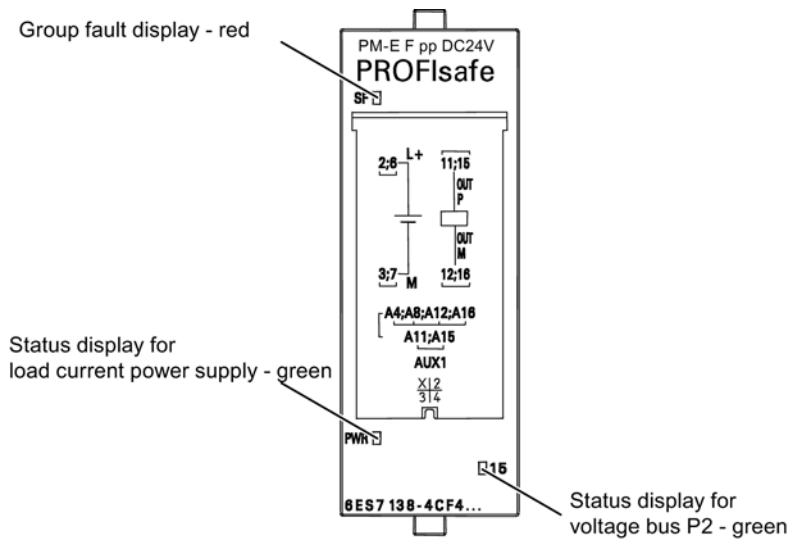

Figure 7-9 Front view PM-E F pp DC24V PROFIsafe

| |
|--|
| ⚠ WARNING |
| The SF LED and the status displays of the inputs/outputs are not designed for safety-related functions and may therefore not be evaluated for safety-related activities. |

Terminal Assignment

The following figure and the following table show the terminal assignment of the PM-E F pp DC 24V PROFIsafe for the supported terminal modules TM-P30S44-A0 or TM-P30C44-A0.

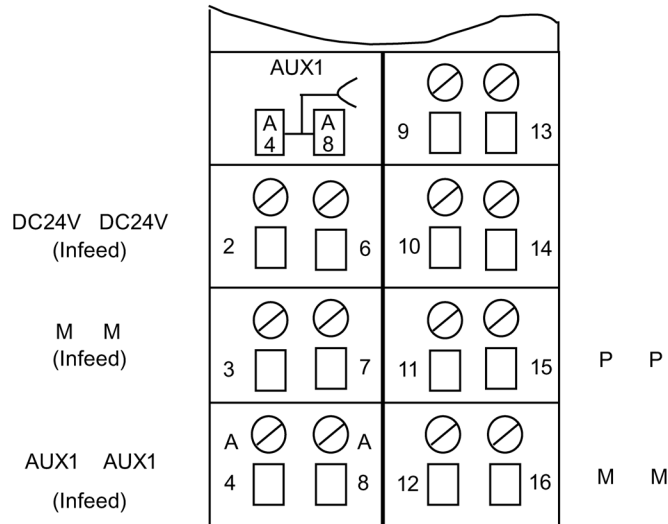

Figure 7-10 Terminal assignment TM-P30S44-A0 or TM-P30C44-A0 for PM-E F pp DC 24V PROFIsafe

Table 7- 7 Terminal assignment of the TM-P30S44-A0 or TM-P30C44-A0

| Terminal | Designation | Designation |
|----------|-------------|---|
| 2 | 24 VDC | 24 VDC rated load voltage for: <ul style="list-style-type: none"> • Inserted power module • Corresponding voltage group and • Voltage bus P2 |
| 3 | M | Ground |
| A 4 | AUX 1 | Any terminal for PE or voltage bus up to the maximum rated load voltage of the module |
| 6 | 24 VDC | 24 VDC rated load voltage for: <ul style="list-style-type: none"> • Inserted power module • Corresponding voltage group and • Voltage bus P2 |
| 7 | M | Ground |
| A 8 | AUX 1 | Any terminal for PE or voltage bus up to the maximum rated load voltage of the module |
| 11 | P | Terminals (relay contacts) for fail-safe switching of voltage bus P2 |
| 12 | M | |
| 15 | P | Terminals (relay contacts) for fail-safe switching of voltage bus P2 |
| 16 | M | |

⚠ CAUTION

If high currents can occur on P and M, you must wire terminals 11 and 15 (P) and 12 and 16 (M) in parallel.

Otherwise, high current loads may cause the terminals to heat up.

7.3.3 Wiring of the PM-E F pp DC24V PROFIsafe

Block Diagram

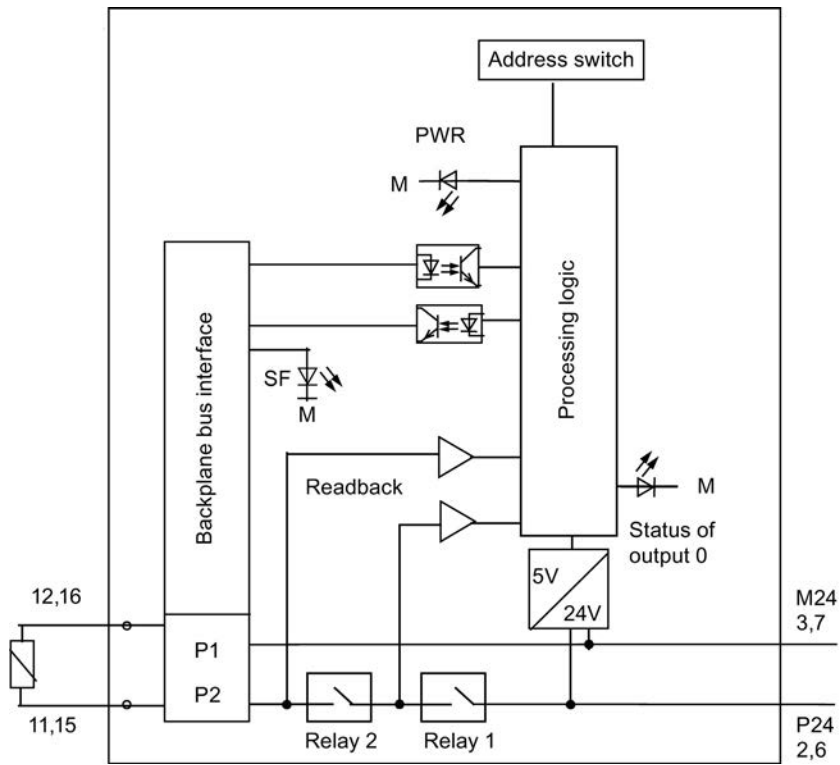

Figure 7-11 Block diagram of the PM-E F pp DC24V PROFIsafe

Wiring Diagram

Wire the PM using the special terminal module.

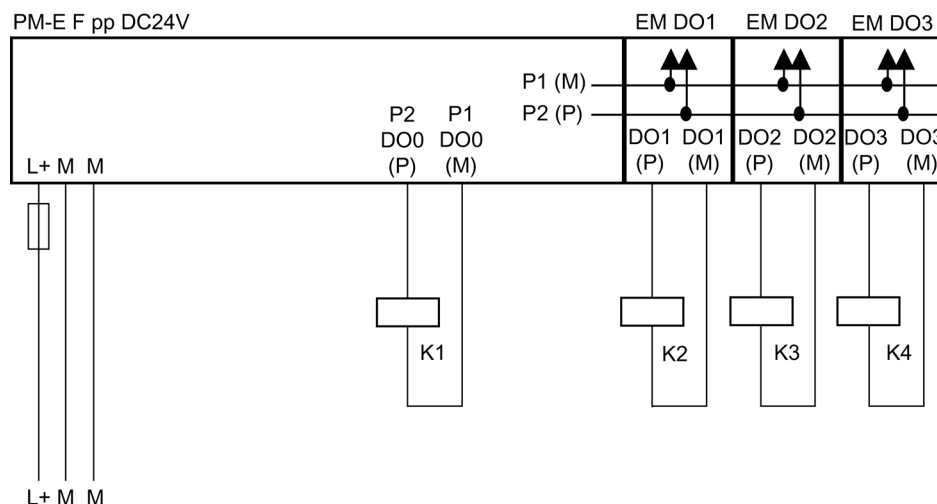

Figure 7-12 Wiring diagram of the PM-E F pp DC24V PROFIsafe

⚠ WARNING

Please always use an external fuse for L+ at the PM-E F pp with the following properties to protect the relay contacts from overload: Circuit-breaker, characteristics B, 10 A.

Relay Output

The two contacts of the relay output are used to switch voltage L+. The switched voltage is supplied to the external terminal module and to the internal voltage buses P1 and P2. This results in two connection options that can be used at the same time, if desired:

- One load can be wired directly to the terminal module (K1 in the figure above).
- Electronic modules can be supplied by means of the internal voltage buses P1 and P2. Loads can be connected to these modules in turn (K2, K3, K4 in the figure above).

⚠ WARNING

In the event of a cross circuit between 2L+ and DO, the controlled actuator is no longer switched off. You should always wire the actuators separately, for example, using sheathed cables or separate cable ducts, in order to prevent any cross-circuits between 2L+ and DO.

7.3.4 Parameters of the PM-E F pp DC24V PROFIsafe

Parameters in *STEP 7*

The table below lists the parameters that can be set for the PM-E F pp DC24V PROFIsafe.

Table 7- 8 Parameters of the PM-E F pp DC24V PROFIsafe

| Parameter | Range | Default | Type of Parameter | Effective Range |
|-----------------------|----------------|------------------------------|-------------------|-----------------|
| F-Parameters: | | | | |
| F_destination_address | 1 to 1022 | is assigned by <i>STEP 7</i> | Static | Module |
| F monitoring time | 10 to 10000 ms | 150 ms | Static | Module |

See also

Configuration and Parameter Assignment (Page 30)

7.3.5 Diagnostic functions of the PM-E F pp DC24V PROFIsafe

Behavior in Case of Supply Voltage Failure

The failure of the PM-E F pp DC24V PROFIsafe power supply is always indicated by the PWR LED on the module (light off). This information is also provided in the module (diagnostic entry). The relay output of the module is passivated.

In the case of a voltage dip in the external auxiliary voltage, the SF LED lights up, the module is passivated.

With the subsequent supply recovery (level must remain above the specified value for at least 1 minute (refer to the technical specifications: voltages, currents, electrical potentials)) the SF LED goes out again, the module remains passivated. The SF LED flashes if there are no other errors, until the error is acknowledged.

Diagnostic functions

The table below provides an overview of the diagnostic functions of the PM-E F pp DC24V PROFIsafe. The diagnostic functions are assigned either to one channel or to the entire module.

Table 7- 9 Diagnostic functions of the PM-E F pp DC24V PROFIsafe

| Diagnostic Function* | Fault number | LED | Effective Range of Diagnostics | can be assigned parameters |
|--|--------------|-----|--------------------------------|----------------------------|
| Short circuit | 1H | SF | Channel | No |
| Overtemperature | 5H | SF | Module | No |
| Internal error | 9H | SF | Module | No |
| Parameter assignment error | 10H | SF | Module | No |
| Sensor voltage or load voltage missing | 11H | SF | Module | No |
| Communication error | 13H | SF | Module | No |
| Safety-related shutdown | 19H | SF | Channel | No |

*: Specially for F-modules; display in *STEP 7*, see "Channel-Specific Diagnostics, Fault Types of Fail-Safe Modules" table

| |
|--|
|  WARNING |
| <p>Before acknowledging the short-circuit diagnosis, remedy the respective error and validate your safety function. To do this, proceed as described in chapter "Fault Diagnostics (Page 55)".</p> |

Causes of Faults and Corrective Measures

The following table contains the possible causes of the faults described for the individual diagnostic messages of the PM-E F pp DC24V PROFIsafe and remedies.

Table 7- 10 Diagnostic messages of the PM-E F pp DC24V PROFIsafe, causes of errors and remedies

| Diagnostic Message | Fault Detection | Possible Causes | Corrective Measures |
|--|----------------------------|--|---|
| Short circuit | For "0" output signal only | Cross-circuit between P1 and L+ | Remedy the cross-circuit and acknowledge the error within 100 hours after the error has occurred |
| | | Internal error | Replace module |
| Overtemperature | Always | Shutdown due to violation of upper or lower temperature limit value in the module case | Check load wiring, check ambient temperature, check whether permissible output current is exceeded for the ambient temperature. Once the fault has been eliminated, the module must be removed and inserted or the power switched off and on. |
| Internal error | Always | Internal module fault has occurred | Replace module |
| Parameter assignment error | Always | Inserted module does not match configuration; incorrect parameter assignment | Correct the configuration (compare actual and preset configuration), and check communication paths. Correct parameter assignment. |
| | | PROFIsafe address set incorrectly in the F-module | Check whether the PROFIsafe address on the module matches the configuration in <i>HW Config</i> |
| Sensor voltage or load voltage missing | Always | Supply voltage not available or too low (e.g. voltage dip on F-module, this can also be caused, among other things, by a short-circuit on the P1/P2 buses) | Check module for correct contact |
| Communication error | Always | Error in communication between F-CPU and module due to defective PROFIBUS connection or higher than permissible EMI, for example | Test PROFIBUS/PROFINET connection. Correct faults |
| | | PROFIsafe monitoring time set too low | Set a greater value for the "F monitoring time" parameter for the module in <i>HW Config</i> |
| | | Configuration of the F-module does not match safety program | Generate safety program again; then load configuration and safety program into F-CPU again |
| Safety-related shutdown | Always | Switching frequency exceeded | Reduce the switching frequency |

Generally Applicable Information on Diagnostics

For information on diagnostics that pertains to all fail-safe modules (for example, for reading out diagnostic functions, or passivating channels), refer to the *Diagnostics* chapter in this manual.

7.3.6 Technical Specifications for PM-E F pp DC24V PROFIsafe

Overview

| Technical specifications | |
|--|--|
| Dimensions and weight | |
| Dimensions W x H x D (mm) | 30 x 81 x 52 |
| Weight | Approx. 80 g |
| Data for Specific Module | |
| Number of outputs | |
| • Relay outputs (PP switching) | 1 |
| Assigned address area | |
| • In the I/O area for inputs | 5 bytes |
| • In the I/O area for outputs | 5 bytes |
| Length of cable | |
| • Unshielded | 200 m, maximum |
| • Shielded | 200 m, maximum |
| Maximum achievable safety class | |
| • in accordance with IEC 61508:2000, ISO 13849-1:2006 or EN ISO 13849-1:2008 | SIL3, Cat4/PLe (for conditions see "Power module PM-E F pp DC24V PROFIsafe") |
| Safety characteristics | SIL3 |
| • Low demand mode (average probability of failure on demand) | < 1.00E-05 |
| • High demand/continuous mode (probability of a dangerous failure per hour) | < 1.00E-10 |
| • Acceptance ID | FM, cULus, CE, C-Tick |
| Voltages, Currents, Potentials | |
| Rated supply voltage L+ | 24 VDC |
| • permissible range ** | 20.4 V to 28.8 V |
| • Power loss ride-through of L+ | None |
| • Power loss ride-through of internal P5 | 5 ms |
| • Reverse polarity protection | No |

| Technical specifications | |
|--|---|
| Total current of the relay output | |
| <ul style="list-style-type: none"> • Horizontal installation <ul style="list-style-type: none"> – Up to 40 °C – Up to 55 °C – Up to 60 °C | 10 A 8 A 7 A |
| <ul style="list-style-type: none"> • Vertical installation <ul style="list-style-type: none"> – Up to 40 °C | 8 A |
| Electrical isolation | |
| <ul style="list-style-type: none"> • Between output and backplane bus | Yes |
| <ul style="list-style-type: none"> • Between output and power supply | No |
| <ul style="list-style-type: none"> • Between output/power supply and shield | Yes |
| Permissible potential difference between | |
| <ul style="list-style-type: none"> • Shield and ET 200S bus connection | 75 V DC/60 V AC |
| <ul style="list-style-type: none"> • Shield and I/O (DOs, P1/P2 buses) | 75 V DC/60 V AC |
| <ul style="list-style-type: none"> • ET 200S bus connection and I/O (DOs, P1/P2 buses) | 250 V AC |
| Isolation in the series tested with | |
| <ul style="list-style-type: none"> • ET 200S bus connection against I/O (DOs, P1/P2 buses) | 2545 V DC/2 s |
| Isolation in the type test tested with | |
| <ul style="list-style-type: none"> • Shield and ET 200S bus connection | 350 V AC/1 min |
| <ul style="list-style-type: none"> • Shield and I/O (DOs, P1/P2 buses) | 350 V AC/1 min |
| <ul style="list-style-type: none"> • ET 200S bus connection and I/O (DOs, P1/P2 buses) | 2830 V AC/1 min |
| <ul style="list-style-type: none"> • Surge voltage test between ET 200S bus connection and I/O (DOs, P1/P2 buses) | 6000 V DC/5 positive and 5 negative pulses |
| Current consumption | |
| <ul style="list-style-type: none"> • From backplane bus | 28 mA, maximum |
| <ul style="list-style-type: none"> • From load voltage L+ (without load) | 100 mA, typical |
| Power loss of the module | 4 W, typical |
| Status, interrupts, diagnostics | |
| Status display | <ul style="list-style-type: none"> • Green LED per channel • Green LED for the load voltage |
| Diagnostic functions | |
| <ul style="list-style-type: none"> • Group fault display | Red LED (SF) |
| <ul style="list-style-type: none"> • Diagnostic information can be displayed | Possible |

| Technical specifications | | |
|--|---------|---|
| Data for Selecting an Actuator for the Relay Output* | | |
| Switching capacity and service life of contacts (voltage 24 VDC) | | |
| • Mechanical endurance (without load) | Current | Number of switching cycles (typ.) |
| | 0 A | 10 million |
| • For resistive load | Current | Number of switching cycles (typ.) |
| | 10 A | 0.23 million |
| | 8 A | 0.3 million |
| | 6 A | 0.38 million |
| | 4 A | 0.5 million |
| | 2 A | 1.0 million |
| | 1 A | 2.0 million |
| • For inductive load in accordance with IEC 60947-5-1, DC13 | Current | Number of switching cycles (typ.) |
| | 10 A | 0.1 million |
| | 8 A | 0.15 million |
| | 6 A | 0.2 million |
| | 4 A | 0.3 million |
| | 2 A | 0.5 million |
| | 1 A | 1.0 million |
| • For lamp load | Power | Number of switching cycles (typ.) |
| | 100 W | 0.12 million |
| Contact protection (internal) | | Internal readback circuit |
| • Between PP relay output and M | | 39 V suppressor diode |
| Wire break monitoring | | No |
| Parallel connection of 2 outputs | | Not possible |
| Control of a digital input | | Possible |
| Switching frequency | | |
| • With resistive load | | 2 Hz symmetrical, maximum |
| • With inductive load in accordance with IEC 60947-5-1, DC13 | | 0.1 Hz symmetrical, maximum |
| • With lamp load | | 2 Hz symmetrical, maximum |
| Short-circuit protection of output | | No, 10 A external circuit-breaker, "B" characteristics required |
| Time, Frequency | | |
| Internal processing times | | See "Response times" |
| Acknowledgment time in safety mode | | 4 ms minimum/8 ms maximum |

| Technical specifications | |
|--|-------------------|
| Protection against overvoltage | |
| Protection of power supply L+ from surge in accordance with IEC 61000-4-5 with external protection elements only | |
| • Symmetrical (L+ to M) | + 1 kV; 1.2/50 µs |
| • Asymmetrical (L+ to PE, M to PE) | + 2 kV; 1.2/50 µs |
| Protection of outputs from surge in accordance with IEC 61000-4-5 with external protection elements only | |
| Symmetrical (DO to M) | + 1 kV; 1.2/50 µs |
| Asymmetrical (DO to PE, M to PE) | + 1 kV; 1.2/50 µs |
| *: For more information on the requirements for encoders and actuators, refer to the section "Wiring and Fitting Modules (Page 45)". | |
| **: Operating below the permissible supply voltage is only permissible for the repair time. See section "Introduction (Page 75)". | |
| Operating above the permissible supply voltage: At a supply voltage > 35.5 V, the fuse blows. | |

7.4 PM-D F DC24V PROFIsafe Power Module

7.4.1 Properties of the PM-D F DC24V PROFIsafe Power Module

Order Number

3RK1903-3BA02

Properties

The PM-D F DC24V PROFIsafe power module disposes of the following properties:

- 6 shutdown groups, SG 1 through SG 6
- Output current of SG 1 through SG 6, each 3 A (total current 5 A)
- Rated load voltage 24 VDC per shutdown group
- Suitable for supplying:
 - Fail-safe motor starters F-DS1e-x, F-RS1e-x
 - Fail-safe frequency converters F-FU
 - Fail-safe connection multipliers F-CM
 - Fail-safe power/expansion modules PM-D F X1
 - Brake control expansion modules xB1, xB2, xB3 and xB4
- Group fault display (SF; red LED)
- Status display per shutdown group (SG 1 through SG 6; green LED)
- Status display for load current power supply (PWR; green LED)
- Status display for electronic power supply (U1; green LED)
- achievable safety class SIL3/Category 4/PLe

Switching the Voltage Buses SG 1 through SG 6 and U 1

The power module can shut down voltage buses SG 1 through SG 6 over 6 digital outputs complying with safety class SIL2/Category 3/PLd or SIL3/Category 4/PLe. The outputs are implemented with two P switches. There is a main switch for all 6 shutdown groups and 6 individual switches connected in series per shutdown group.

The voltage bus U 1 (electronics power supply for the motor starters) is supplied with 24 VDC. **When overvoltage or undervoltage occurs**, U 1 is switched off by two P switches and the downstream motor starters are passivated. **In the event of a safety shutdown** of motor starters, U 1 is not switched off.

Conditions for Achieving Safety Class

The conditions for achieving the various safety classes are summarized in the table below.

Table 7- 11 PM-D F DC24V PROFIsafe: Conditions for SIL/Categories/PL

| Condition | Achievable SIL/Category/PL |
|--|----------------------------|
| Fail-safe motor starters are expanded with the expansion modules: <ul style="list-style-type: none"> • Brake control xB3 and xB4 | SIL2/Category 3/PLd |
| Power supply of: <ul style="list-style-type: none"> • Exclusively fail-safe motor starters F-DS1e-x and F-RS1e-x • Fail-safe frequency converters F-FU • Fail-safe connection multipliers F-CM • Fail-safe power/expansion modules PM-D F X1 Fail-safe motor starters are expanded with the expansion modules: <ul style="list-style-type: none"> • Brake Control xB1 and xB2 | SIL3/Category 4/PLe |

Note

The safety classes SIL2/Category 3/PLd or SIL3/Category 4/PLe listed in the table above can only be achieved with the modules specified in the "Condition" column. Configurations with other modules (e.g. motor starter DS1-x/RS1x, DS1e-x/RS1e-x, DSS1e-x) are not permitted for safety-related applications.

7.4.2 Terminal Assignment of the PM-D F DC24V PROFIsafe

Front View

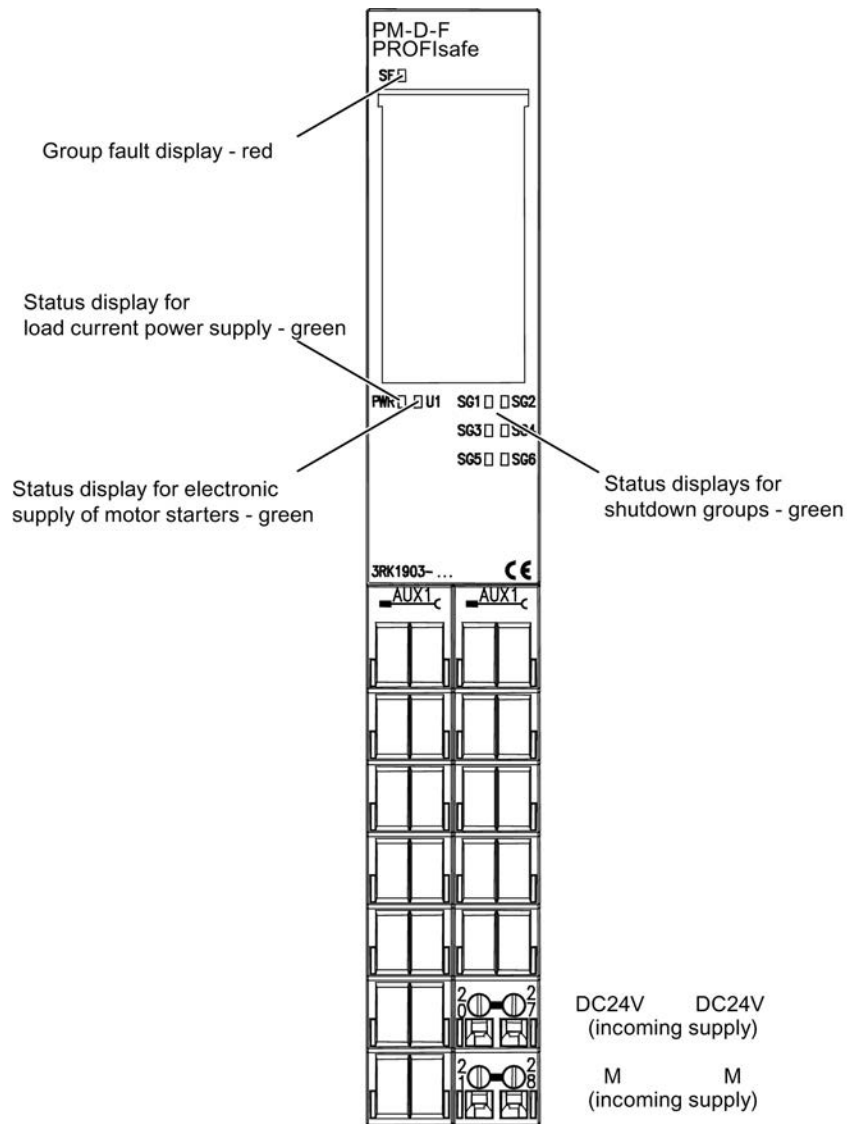



Figure 7-13 Front View of PM-D F DC24V PROFIsafe

| |
|---|
|  WARNING |
| <p>The SF LED and the status displays of the inputs/outputs are not designed for safety-related functions and may therefore not be evaluated for safety-related activities.</p> |

Terminal assignment

On the PM-D F DC24V PROFIsafe, you connect only the 24 V DC load voltage power supply and chassis. Wire the power module using the special terminal module.

The following table shows the terminal assignment of the PM-D F DC24V PROFIsafe for the supported terminal module TM-PF30S47-F1 (order number 3RK1 903-3AA00).

Table 7- 12 Terminal Assignment of the TM-PF30S47-F1

| Terminal | | Designation |
|----------|--------|---|
| 20 | 24 VDC | 24 VDC rated load voltage for: <ul style="list-style-type: none">• Inserted power module and• Voltage buses SG 1 through SG 6 and U1 |
| 21 | M | Ground |
| 27 | 24 VDC | 24 VDC rated load voltage for: <ul style="list-style-type: none">• Inserted power module and• Voltage buses SG 1 through SG 6 and U1 |
| 28 | M | Ground |

7.4.3 Wiring of the PM-D F DC24V PROFIsafe

Block Diagram

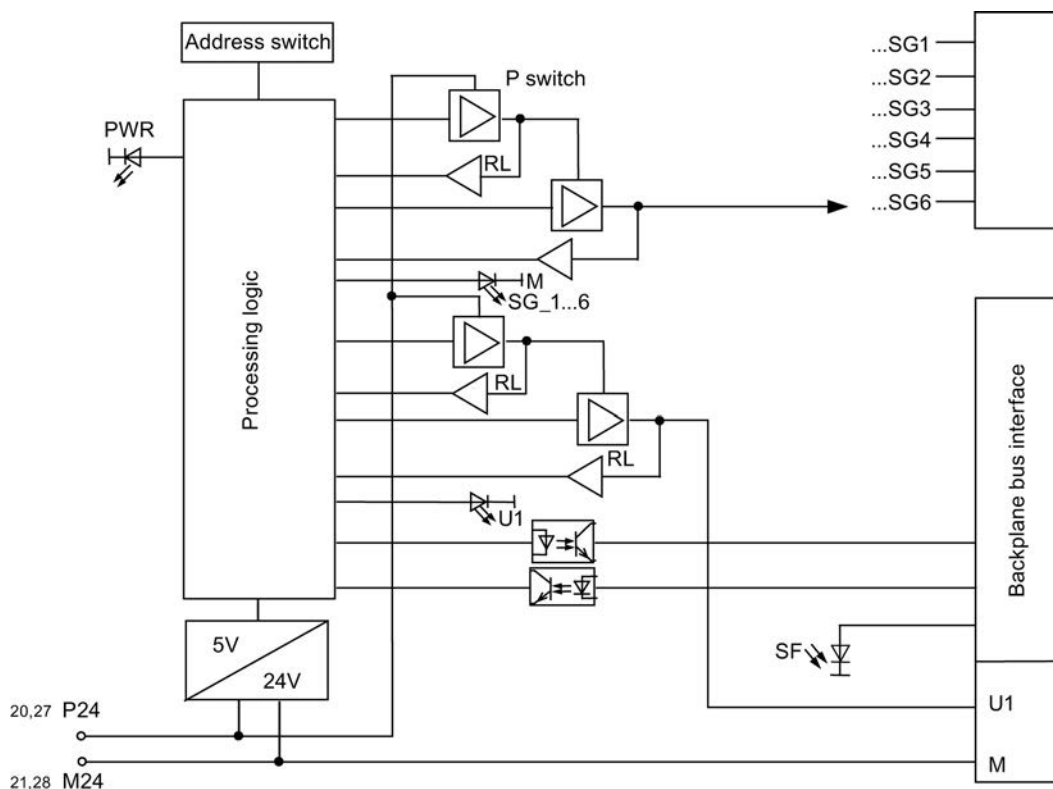

Figure 7-14 Block diagram of the PM-D F DC24V PROFIsafe

7.4.4 Parameters of the PM-D F DC24V PROFIsafe

Parameters in STEP 7

The table below lists the parameters that can be assigned for the PM-D F DC24V PROFIsafe.

Table 7- 13 Parameters of the PM-D F DC24V PROFIsafe

| Parameter | Range | Default | Type of Parameter | Effective Range |
|-----------------------|----------------|--------------------|-------------------|-----------------|
| F-Parameters: | | | | |
| F_destination_address | 1 to 1022 | Assigned by STEP 7 | Static | Module |
| F monitoring time | 10 to 10000 ms | 150 ms | Static | Module |

7.4.5 Diagnostic Functions of PM-D F DC24V PROFIsafe

Behavior in Case of Supply Voltage Failure

The failure of the PM-D F DC24V PROFIsafe power supply is always indicated by the PWR LED on the module (light off). The failure of the electronics power supply is indicated by the U1 LED of the module (light off). This information is also provided on the module (entry in diagnostics data). Either all shutdown groups of the module (SG 1 through SG 6) are passivated or, in the case of channel-specific passivation, only the relevant shutdown groups are passivated.

In the case of a voltage dip in the external auxiliary voltage, the SF LED lights up, the module is passivated.

With the subsequent supply recovery (level must remain above the specified value for at least 1 minute (refer to the technical specifications: voltages, currents, electrical potentials)) the SF LED goes out again, the module remains passivated. The SF LED flashes if there are no other errors, until the error is acknowledged.

Diagnostic functions

The table below provides an overview of the diagnostic functions of the PM-D F DC24V PROFIsafe. The diagnostic functions are assigned either to a channel or the entire module.

Table 7- 14 Diagnostic functions of the PM-D F DC24V PROFIsafe

| Diagnostic Function* | Fault Number | LED | Effective Range of Diagnostics | Can be assigned parameters |
|---|--------------|-----|--------------------------------|----------------------------|
| Short circuit | 1H | SF | Channel | No |
| Overtemperature | 5H | SF | Module | No |
| Internal error | 9H | SF | Module | No |
| Parameter assignment fault | 10H | SF | Module | No |
| Sensor voltage or load voltage missing | 11H | SF | Module | No |
| Communication problem | 13H | SF | Module | No |
| *: Specially for F-modules; display in <i>STEP 7</i> , see "Channel-Specific Diagnostics, Fault Types of Fail-Safe Modules" table | | | | |

Causes of Faults and Corrective Measures

The following table contains the possible causes of the faults described for the individual diagnostic messages of the PM-D F DC24V PROFIsafe and remedies.

Table 7- 15 Diagnostic messages of the PM-D F DC24V PROFIsafe, causes of errors and remedies

| Diagnosics Message | Fault Detection | Possible Causes | Corrective Measures |
|-----------------------------------|-----------------|--|--|
| Short circuit | Always | Short circuit in the actuator | Eliminate short-circuit/cross-circuit; once the fault has been eliminated, the module must be removed and inserted, or the power switched OFF and ON |
| | | Cross circuit in the actuator | |
| | | Internal error | Replace module |
| Overtemperature | Always | Shutdown due to violation of upper or lower temperature limit in the module case. | Check load wiring, check ambient temperature. Once the fault has been eliminated, the module must be removed and inserted, or the power switched off and on. |
| Internal error | Always | Internal module fault has occurred | Replace module |
| Parameter assignment error | Always | Inserted module does not match configuration. Incorrect parameter assignment | Correct the configuration (compare actual and preset configuration), and check communication paths. Correct the parameter assignment. |
| | | PROFIsafe address set incorrectly in the F-module | Check whether the PROFIsafe address on the module matches the configuration in <i>HW Config</i> |
| external auxiliary supply missing | Always | No supply voltage or supply voltage is too low. | Check module for correct contact |
| Communication error | Always | Error in communication between F-CPU and module due to defective PROFIBUS connection or higher than permissible EMI, for example | Test PROFIBUS/PROFINET connection. Correct faults |
| | | PROFIsafe monitoring time set too low | Set a greater value for the "F monitoring time" parameter for the module in <i>HW Config</i> |

Generally Applicable Information on Diagnostics

For information on diagnostics that pertains to all fail-safe modules (for reading out diagnostic functions, passivating channels, for example), refer to *Diagnostics* chapter in this manual.

See also

Fault Diagnostics (Page 55)

7.4.6 Technical Specifications of the PM-D F DC24V PROFIsafe

Overview

| Technical specifications | |
|--|---------------------------------------|
| Dimensions and weight | |
| Dimensions W x H x D (mm) | 30 x 196.5 x 117.5 |
| Weight | Approx. 112 g |
| Data for Specific Module | |
| Number of outputs (P/P switching) | 6 shutdown groups (SG 1 through SG 6) |
| Internal power supply for bus | U 1 |
| Assigned address area | |
| • In the I/O area for inputs | 5 bytes |
| • In the I/O area for outputs | 5 bytes |
| Maximum achievable safety class | |
| • in accordance with IEC 61508:2000, ISO 13849-1:2006 or EN ISO 13849-1:2008 | SIL3, Cat.4/PLe |
| Safety characteristics | SIL3 |
| • Low demand mode (average probability of failure on demand) | < 1.00E-05 |
| • High demand/continuous mode (probability of a dangerous failure per hour) | < 1.00E-10 |
| • Acceptance ID | CE, UL, CSA |
| Voltages, Currents, Potentials | |
| Rated supply voltage L+ | 24 VDC |
| • permissible range * | 21.6 V to 26.4 V |
| • Power loss ride-through of L+ | None |
| • Power loss ride-through of internal P5 | 5 ms |
| • Reverse polarity protection | No |
| Total current of outputs | |
| • Horizontal installation | Brief/permanent |
| – Up to 40 °C | 10 A/5 A |
| – Up to 60 °C | 10 A/4 A |
| • Vertical installation | Brief/permanent |
| – Up to 40 °C | 10 A/4 A |
| Electrical isolation | |
| • Between channels and backplane bus | Yes |
| • Between channels and power supply | No |
| • Between channels | No |
| • Between channels/power supply and shield | Yes |

| Technical specifications | |
|---|---|
| Permissible potential difference between | |
| • Shield and ET 200S bus connection | 75 V DC/60 V AC |
| • Shield and I/O (SGs, U 1 bus) | 75 V DC/60 V AC |
| • ET 200S bus connection and I/O (SGs, U 1 bus) | 250 V AC |
| Isolation in the series tested with | |
| • ET 200S bus connection with I/O (SGs, U 1 bus) | 2545 V DC/1 s |
| Isolation in the type test tested with | |
| • Shield and ET 200S bus connection | 350 V AC/1 min |
| • Shield and I/O (SGs, U 1 bus) | 350 V AC/1 min |
| • ET 200S bus connection and I/O (SGs, U 1 bus) | 2830 V AC/1 min |
| • Surge voltage test between ET 200S bus connection and I/O (SGs, U1 bus) | 6000 V DC/5 positive and 5 negative pulses |
| Current consumption | |
| • From backplane bus | 28 mA, maximum |
| • From load voltage L+ (without load) | 100 mA, typical |
| Power loss of the module | 4 W, typical |
| Status, interrupts, diagnostics | |
| Status display | <ul style="list-style-type: none"> • Green LED per SG • Green LED for electronic power supply • Green LED for the load voltage |
| Diagnostic functions | |
| • Group fault display | Red LED (SF) |
| • Diagnostic information can be displayed | Possible |
| Time, Frequency | |
| Internal processing times | See " <i>Response times</i> " |
| Acknowledgment time in safety mode | 4 ms minimum/8 ms maximum |
| Protection against overvoltage | |
| Protection of power supply L+ from surge in accordance with IEC 61000-4-5 with external protection elements only | |
| • Symmetrical (L+ to M) | + 1 kV; 1.2/50 μ s |
| • Asymmetrical (L+ to PE, M to PE) | + 2 kV; 1.2/50 μ s |
| *: Operating below the permissible supply voltage is only permissible for the repair time. See section "Introduction (Page 75)". Operating above the permissible supply voltage: At a supply voltage > 35.5 V, the fuse blows. | |

7.5 4/8 F-DI DC24V PROFIsafe Digital Electronic Module

7.5.1 Properties of the 4/8 F-DI DC24V PROFIsafe Digital Electronic Module

Order Number

6ES7138-4FA05-0AB0

Properties

The 4/8 F-DI DC24V PROFIsafe digital electronic module possesses the following properties:

- 8 inputs (SIL2/Category 3/PLd) or 4 inputs (SIL3/Category 3 or Category 4/PLe)
- 24 VDC rated input voltage
- Suitable for switches and 3/4-wire proximity switches
- 2 short-circuit-proof sensor supplies, each one for four inputs
- External sensor supply possible
- Group fault display (SF; red LED)
- Status display for each input (green LED)
- one fault display for each sensor supply (1VsF and 2VsF; red LED)
- Assignable diagnostics
- Module-internal diagnostic buffer available
- Firmware update
- Identification data I&M

Power Modules Suitable for SIL2 or SIL3

Table 7- 16 EM 4/8 F-DI DC24V PROFIsafe: Power modules for SIL/Category/PL

| Power module | achievable SIL/Category/PL |
|--|--|
| Supply through PM-E DC24V, PM-E DC24..48V/AC24..230V or PM-E DC24..48V | with 1oo1 sensor evaluation (8 F-DI) SIL2/Category 3/PLd with 1oo2 sensor evaluation (4 F-DI) SIL3/Category 4/PLe |

Capacitive Crosstalk of Digital Input/Output Signals

refer to *"Characteristics of the power module PM-E F pm DC24V PROFIsafe"*

7.5.2 Terminal Assignment of the EM 4/8 F-DI DC24V PROFIsafe

Front View

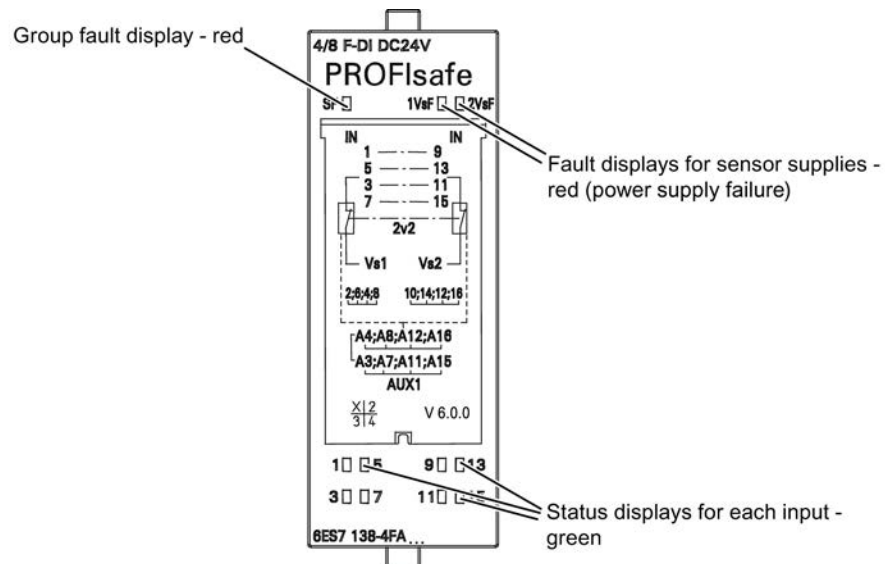
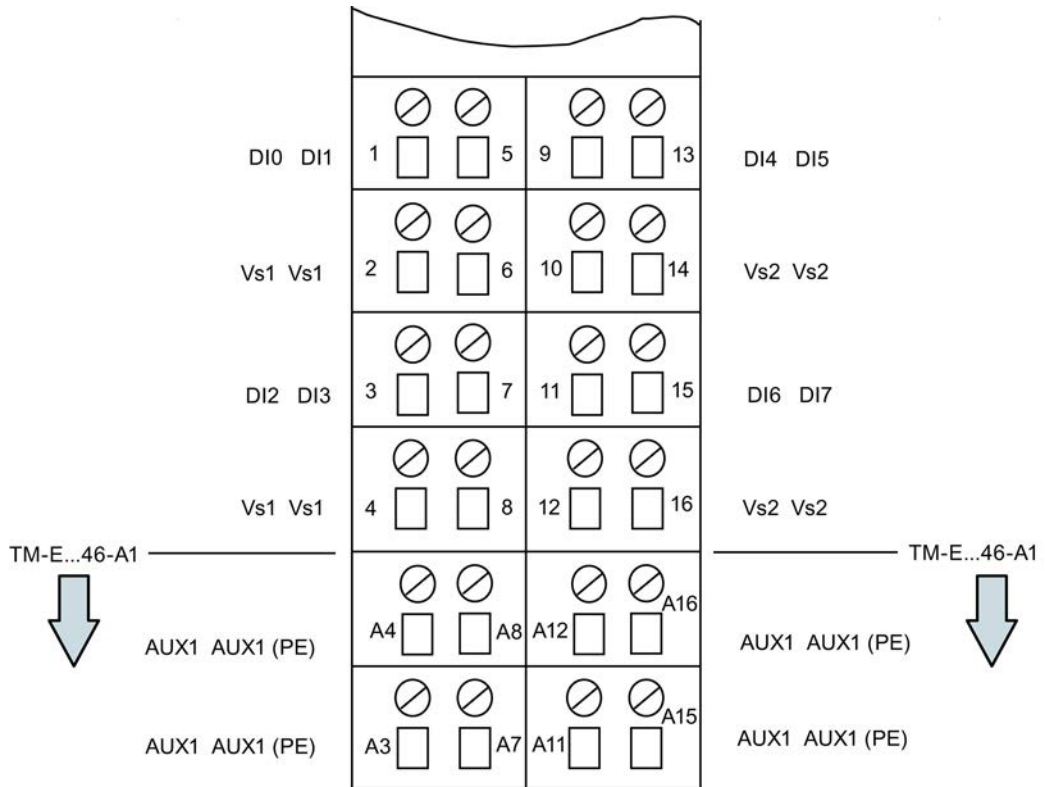

Figure 7-15 Front view EM 4/8 F-DI DC24V PROFIsafe

Terminal Assignment

The figure below shows the terminal assignment of the EM 4/8 F-DI DC24V PROFIsafe for the supported terminal module TM-E30S44-01, TM-E30C44-01, TM-E30S46-A1 and TM-E30C46-A1.



- DI Fail-safe digital input
 - Vs1 Internal sensor power supply 1 for DI 0 to DI 3
 - Vs2 Internal sensor power supply 2 for DI 4 to DI 7
- For TM-E...46-A1 AUX 1 bus implemented. Connection to terminals A3 through A16 for any connection of PE (individual grouping of sensor supplies possible)

Figure 7-16 Terminal assignment TM-E...44-01/TM-E...46-A1 for EM 4/8 F-DI DC24V PROFIsafe

7.5.3 Wiring of the EM 4/8 F-DI DC24V PROFIsafe

Block diagram

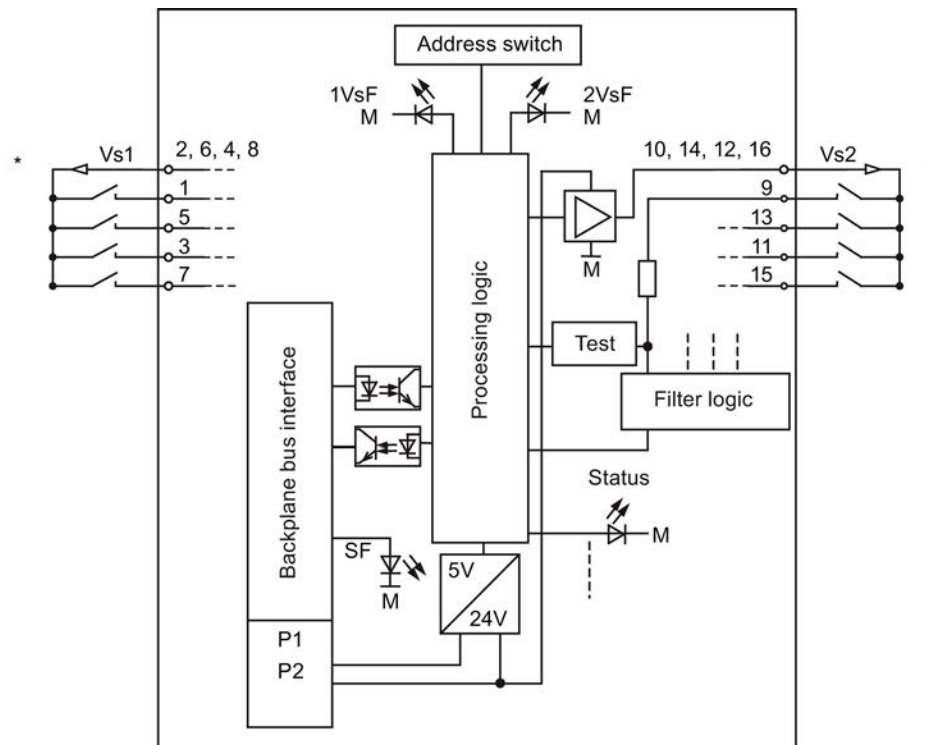

* The representation of NO contacts matches the module labeling. Usually, NC or NO combinations are used as sensor contacts (to ensure the safe state of process variables).

Figure 7-17 Block Diagram of EM 4/8 F-DI DC24V PROFIsafe

7.5.4 Parameters of the EM 4/8 F-DI DC24V PROFIsafe

Parameters in *STEP 7*

The table below lists the parameters that can be set for the EM 4/8 F-DI DC24V PROFIsafe.

Table 7- 17 Parameters of the EM 4/8 F-DI DC24V PROFIsafe

| Parameter | Range | Default | Type of Parameter | Effective Range |
|---|--|-------------------------------|-------------------|-----------------|
| F-Parameters: | | | | |
| F_destination_address | 1 to 1022 | is assigned by <i>STEP 7</i> | Static | Module |
| F monitoring time | 10 to 10,000 ms | 150 ms | Static | Module |
| Module Parameters: | | | | |
| Input delay | 0.5 ms, 3 ms, 15 ms | 3 ms | Static | Module |
| Short-circuit test | Cyclic/disable | Cyclic | Static | Module |
| Behavior after channel faults* | Passivate the entire module/Passivate the channel | Passivate the entire module | Static | Module |
| Channel n, n+4 | Activated/deactivated | Activated | Static | Channel group |
| Sensor supply | internal/external | internal | Static | Channel group |
| Sensor evaluation | 1oo2 evaluation / 1oo1 evaluation | 1oo2 evaluation | Static | Channel group |
| Type of sensor interconnection | 1-channel; 2-channel equivalent; 2-channel, non-equivalent | 2-channel equivalent | Static | Channel group |
| Behavior at discrepancy | Provide last valid value; provide 0 value | Provide last valid value | Static | Channel group |
| Discrepancy time | 10 to 30,000 ms | 10 ms | Static | Channel group |
| Reintegration after discrepancy error | Zero signal test not required/zero signal test required | Zero signal test not required | Static | Channel group |
| * This setting is only relevant when optional package <i>S7 Distributed Safety V5.4</i> or higher is installed. | | | | |

Input Delay of 3 ms Parameter

Note

When operating with 3 ms input delay, you must always use shielded cables if there is a danger of overvoltage on the signal lines (see section "Electromagnetic Compatibility") to prevent possible passivation of the fail-safe digital inputs and shutdown of the sensor power supply.

If unshielded signal lines are used, the safe behavior of the process variables is ensured.

Effects of parameter changes on the short-circuit test

When the cyclic short-circuit test is selected, the parameter input delay directly affects the test pulse duration of the sensor supply. The length of a test pulse is around 1 ms plus the configured input delay time.

You can find detailed information about the bit pattern test for the fail-safe ET 200S modules, the response of the employed modules and the available parameters on the Internet (<http://support.automation.siemens.com/WW/view/en/44452714>).

Short-Circuit Test Parameter

This parameter can be used to activate short-circuit detection for channels set up for "internal sensor supply." The internal sensor supplies must be used for the channels configured in this way (see also *"Applications for the 4/8 F-DI DC24V PROFIsafe electronic module"*).

The short-circuit test parameter is used to activate or deactivate the cyclic short-circuit test of the channels with "internal sensor supply". The short-circuit test is only useful for simple switches that do not have their own power supply. For switches with power supply, for example, 3/4-wire proximity switches, the short-circuit test is not possible. Use the "external sensor supply" for these channels, if you do not want to disable the "short-circuit test" higher-level module parameter because of the other channels.

Sensor supply parameter

This parameter can be used to activate the "Internal sensor supply" of the F-module. This setting is required for using the cyclic short-circuit test.

Effects of parameter changes on the short-circuit test

The sensor supply parameter is used to switched the evaluation of the test pulse on or off.

When the internal sensor supply and cyclic short-circuit test are selected, the test pulses of associated sensor supply must be detected with a 1 signal at a digital input. If no test pulses or those of the other sensor supplies are detected, this is considered an error and the channel (or module depending on configuration) is passivated.

You can find detailed information about the bit pattern test for the fail-safe ET 200S modules, the response of the employed modules and the available parameters on the Internet (<http://support.automation.siemens.com/WW/view/en/44452714>).

Note

When there are different sensor supply parameter settings (internal/external) for the individual channel groups, the applications shown in the next section apply to specific channel groups.

Behavior at discrepancy parameter

For "Behavior at Discrepancy," you assign the value that is to be made available to the safety program in the F-CPU during the time that a discrepancy exists between two input channels, i.e., during the discrepancy time. To program behavior at discrepancy:

- "Provide last valid value" or
- "Provide 0 value"

Requirements

Parameter settings:

- Sensor evaluation: "1oo2 evaluation"

"Provide last valid value"

The last valid value (old value) from before the discrepancy occurred is immediately made available to the safety program in the fail-safe CPU as soon as a discrepancy is detected between the signals of the two input channels involved. This value remains available until the discrepancy is cleared, or until the discrepancy time has expired and a discrepancy error is detected. The sensor-actuator response time is extended by this time.

As a result, the discrepancy time for sensors connected over two channels for high-speed reactions must be tuned to short response times. Thus, it makes no sense, for example, if sensors connected via 2 channels with a discrepancy time of 500 ms trigger a time-critical shutdown. In the worst case scenario, the sensor-actuator response time is extended by an amount approximately equal to the discrepancy time:

- For this reason, position the sensors in the process in such a way as to **minimize discrepancy**.
- Then select the **shortest possible** discrepancy time which is also sufficient to compensate for faulty triggering of discrepancy errors.

"Provide 0 value"

The "0" value is immediately made available to the safety program in the F-CPU as soon as discrepancy is detected between the signals of the two input channels involved.

If the "Provide 0 value" parameter is set, the sensor-actuator response time will not be influenced by the discrepancy time.

Discrepancy Time Parameter

You can define the discrepancy time for each channel pair with this parameter. The entered value is rounded to a multiple of 10 ms.

Requirements

Parameter settings:

- Sensor evaluation: "1oo2 evaluation"
- Type of sensor interconnection: "2-channel equivalent" or "2-channel non-equivalent"

Discrepancy Analysis and Discrepancy Time

When using a dual-channel, or non-equivalent sensor, or two single-channel sensors which measure the same physical process variable, the sensors will interact with a slight time delay because of precision limitations in their arrangement.

The discrepancy analysis for equality/non-equality is used at fail-safe inputs to detect errors based on the timing of two signals with the same functionality. Discrepancy analysis is initiated when different levels (when testing for nonequivalence: same voltage levels) are detected at two associated input signals. A test is conducted to determine whether the difference in levels (when testing for nonequivalence: the match) has disappeared after expiration of a specified time known as the discrepancy time. If not, this means that a discrepancy error exists.

In most cases, a discrepancy time is started, but does not fully expire since the signal differences are cleared within a short time.

Select a discrepancy time of sufficient length so that in case of no error, the difference between the two signals (when checking for nonequivalence: the consistency) has definitely disappeared before the discrepancy time expires.

Response during discrepancy time

While the programmed discrepancy time is running internally on the module, either the **last valid value** or "0" is returned to the safety program on the F-CPU by the input channels involved, depending on the parameter settings for the Behavior at discrepancy.

Response after expiration of discrepancy time

If the input signals are not equivalent following expiration of the specified discrepancy time (when checking for nonequivalence: no inequality), for example due to wire break at a sensor line, the system detects a discrepancy error and generates a "discrepancy" diagnostic message in the diagnostic buffer of the F-I/O module to identify the faulty channels.

Reintegration After Discrepancy Error Parameter

With this parameter you can define the criteria for clearing discrepancy errors which, when fulfilled, facilitate reintegration of the relevant input channels. Programming options:

- "Zero signal test required" or
- "Zero signal test not required"

Requirements

Parameter settings:

- Sensor evaluation: "1oo2 evaluation"

"Zero signal test required"

When "Zero signal test required" is set, a discrepancy error is not considered cleared until a zero signal is set at both input channels.

When using non-equivalent sensors, that is, "2-channel non-equivalent" is set at the "Type of sensor interconnection" parameter, the zero signal must again be set at the channel which provides the wanted signal.

"Zero signal test not required"

When "Zero signal test not required" is set, a discrepancy error is considered cleared when a discrepancy no longer exists between the two input channels.

SIMATIC S7 F-modules, for which you cannot program the "Reintegration after discrepancy error" parameter, also behave in this way.

7.5.5 Applications for the 4/8 F-DI DC24V PROFIsafe Electronic Module

Selecting the Application

The diagram below supports you in selecting an application which suits your fail-safe requirements. The following sections provide information for each application on wiring the F-module, and which specific parameters you must program in *STEP 7*.

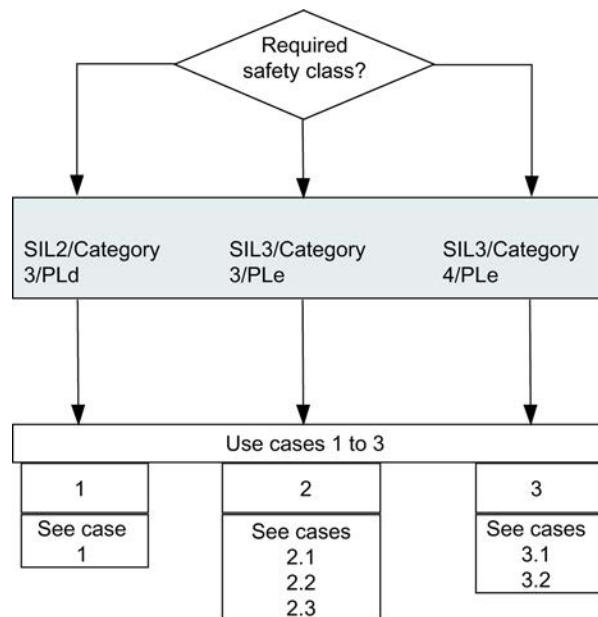

Figure 7-18 Use case selection - 4/8 F-DI DC24V PROFIsafe electronic module

WARNING

The maximum Safety Integrity Level is determined by the sensor quality and the length of the proof-test interval according to the IEC 61508:2000 standard. If the sensor quality does not meet Safety Integrity Level requirements, always wire redundant sensors and connect them via two channels.

Conditions for achieving SIL/category/PL

The table below lists the conditions which have to be met for achieving the various safety categories.

Table 7- 18 EM 4/8 F-DI DC24V PROFIsafe: Conditions for achieving SIL/Category/PL

| Application | Sensors | Sensor Evaluation | Sensor Supply | achievable SIL/Category/PL |
|-------------|--------------------------|-------------------|--------------------------------------|----------------------------|
| 1 | 1-channel | 1oo1 | Internal, with short-circuit test | 2 / 3 / d |
| | | | Internal, without short-circuit test | |
| | | | External | |
| 2.1 | 1-channel | 1oo2 | Internal, with short-circuit test | 3 / 3 / e |
| | | | Internal, without short-circuit test | |
| | | | External | |
| 2.2 | 2-channel equivalent | 1oo2 | Internal, without short-circuit test | 3 / 4 / e |
| | | | External | |
| 2.3 | 2-channel, nonequivalent | 1oo2 | Internal, without short-circuit test | 3 / 4 / e |
| | | | External | |
| 3.1 | 2-channel equivalent | 1oo2 | Internal, with short-circuit test | 3 / 4 / e |
| 3.2 | 2-channel, nonequivalent | | | |

Note

You can operate the various inputs of an F-DI module simultaneously in SIL2/Category 3/PLd and SIL3/Category 3 or 4/PLe. You only have to connect the inputs and assign the parameters as shown in the following sections.

Sensor Requirements

Please note the information in section *"Requirements for Sensors and Actuators"* when using sensors for safety-related applications.

7.5.6 Application 1: SIL2/Category 3/PLd safety mode

Sensor supply

The EM 4/8 F-DI DC24V PROFIsafe provides sensor supply Vs1 for Inputs 0 to 3 and sensor supply Vs2 for Inputs 4 to 7. The sensor supply can be powered internally or externally.

Wiring Diagram for Application 1 – Connecting One Sensor to One Channel

One sensor is connected to one channel (1oo1 evaluation) for each process signal.

The wiring is carried out on the appropriate terminal module.

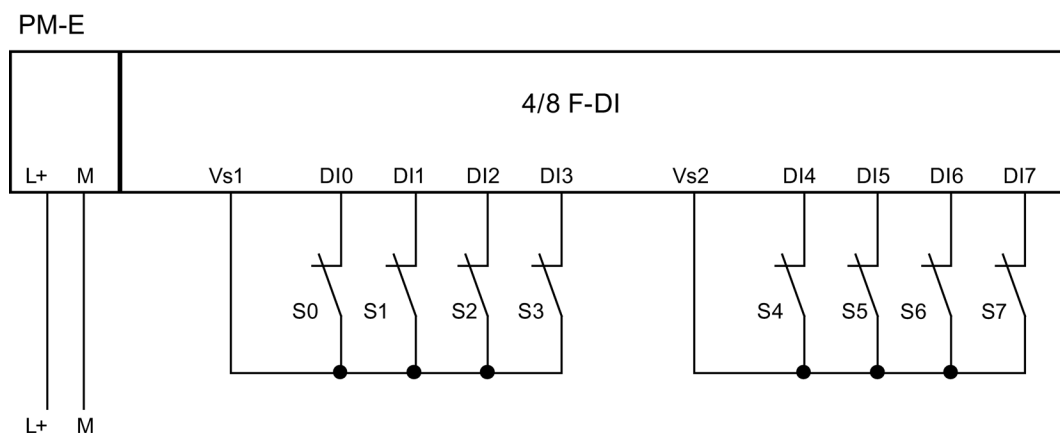

Figure 7-19 Wiring diagram EM 4/8 F-DI DC24V PROFIsafe - one sensor connected via one channel, internal sensor supply

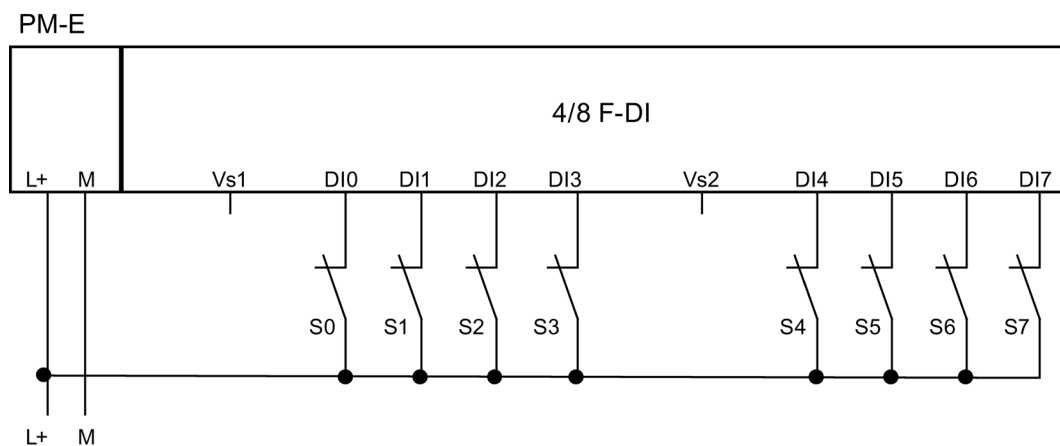



Figure 7-20 Wiring diagram EM 4/8 F-DI DC24V PROFIsafe - one sensor connected via one channel, internal sensor supply

| |
|--|
|  WARNING |
| To achieve SIL2/Category 3/PLd using this wiring, you must use a suitably qualified sensor. |

Assignable Parameters for Application 1

Set the "Sensor evaluation" parameter to "1001" for the corresponding input.

You can activate or deactivate the "short-circuit test" parameter. For digital inputs connected to an external supply, set the "Sensor supply" parameter for the corresponding digital input to "external". The program will otherwise report a "short circuit" diagnostics event if the "short-circuit test" is activated.

Special Features of Fault Detection (Application 1)

The following table presents fault detection according to the sensor supply and the parameter assignment for the short-circuit test:

Table 7- 19 EM 4/8 F-DI DC24V PROFIsafe: Fault Detection (Application 1)

| Example of Fault | Fault detection if ... | | |
|--|---|---|------------------------|
| | internal sensor supply and short-circuit test activated | internal sensor power supply and short-circuit test are deactivated | external sensor supply |
| Short circuit in DI 0 with DI 1 | No | No | No |
| Short circuit in DI 0 with DI 4 | Yes* | No | No |
| P-short circuit in DI 0 | Yes | No | No |
| M-short circuit in DI 0 | Yes* | Yes* | No |
| Discrepancy error | - | - | - |
| P-short circuit in sensor supply 1 | Yes | no | No |
| M-short circuit in sensor supply 1, or sensor supply 2 defective | Yes | Yes | Yes |
| Short circuit in sensor supply 1 with sensor supply 2 | Yes | no | no |
| Fault in read/test circuit | Yes | Yes | Yes |
| Supply voltage fault | Yes | Yes | Yes |
| *: Fault detection only if signals are corrupted. That is, the signal reading differs compared to the sensor signal. If there is no signal corruption with respect to the sensor signal, fault detection is not possible and is not required from a safety standpoint. | | | |

| |
|--|
|  WARNING |
| If the short-circuit test is not activated or the sensor supply to digital inputs is set to "external", the wiring between the sensor and the input channel must be short circuit-proof. |

7.5.7 Application 2: Safety mode SIL3/Category 3/PLe

Assigning Inputs to Each Other

The EM 4/8 F-DI DC24V PROFIsafe has 8 fail-safe inputs, DI 0 through DI 7 (SIL2). A pair of these inputs can each be used as one input (SIL3). The following assignment applies:

- DI 0 with DI 4
- DI 1 with DI 5
- DI 2 with DI 6
- DI 3 with DI 7

Sensor supply

The EM 4/8 F-DI DC24V PROFIsafe provides sensor supply Vs1 for Inputs 0 to 3 and sensor supply Vs2 for Inputs 4 to 7.

Exceptions:

- Application 2.1, see Figure 7-21 Wiring diagram EM 4/8 F-DI DC24V - one sensor connected via one channel to two inputs, internal sensor supply (Page 136) and Figure 7-22 Wiring diagram EM 4/8 F-DI DC24V - one sensor connected via one channel to two inputs, external sensor supply (Page 137)
- Application 2.3, see Figure 7-26 Wiring diagram EM 4/8 F-DI DC24V - a non-equivalent sensor connected non-equivalently via two channels, internal sensor supply (Page 142) , Figure 7-27 Wiring diagram EM 4/8 F-DI DC24V - a non-equivalent sensor connected non-equivalently via two channels, external sensor supply (Page 142) and Figure 7-28 Wiring diagram EM 4/8 F-DI DC24V - two single-channel sensors connected non-equivalently via two channels, internal sensor supply (Page 143)

The sensors can be powered internally or externally.

Wiring diagram for application 2.1 - Connecting one channel of one sensor to two inputs

Single-channel connection of a sensor to two inputs of the F-module for each process signal (1oo2 evaluation).

Note

If you power the sensors from the F-DI module, you must use the internal sensor supply Vs1. Connection to Vs2 is not possible.

The wiring is carried out on the appropriate terminal module.

PM-E

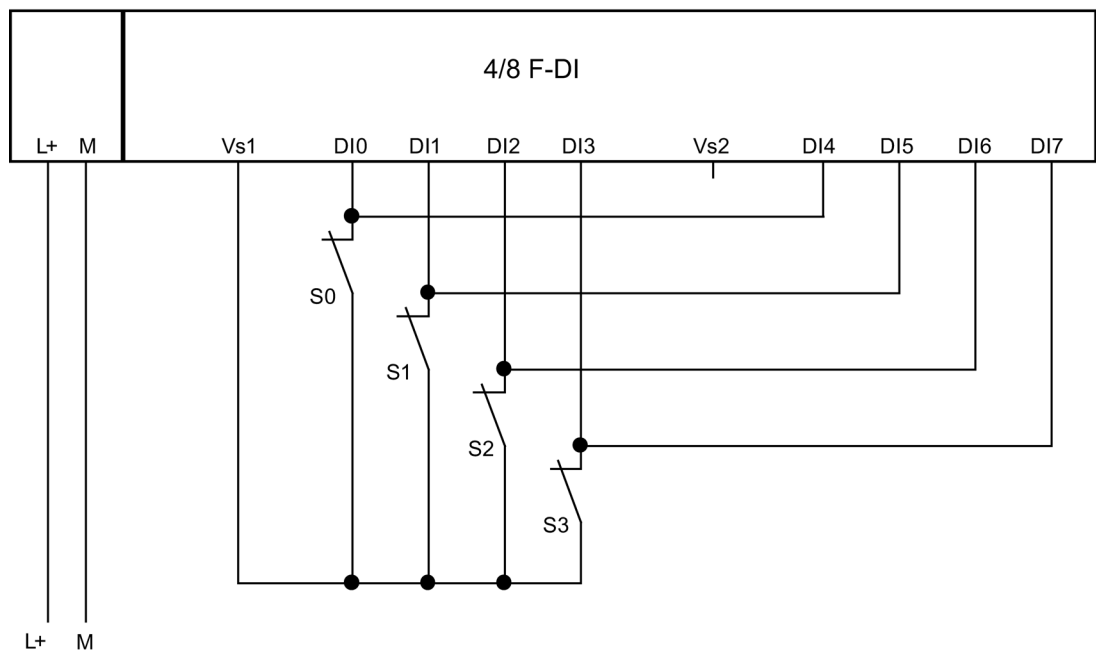

Figure 7-21 Wiring diagram EM 4/8 F-DI DC24V - one sensor connected via one channel to two inputs, internal sensor supply

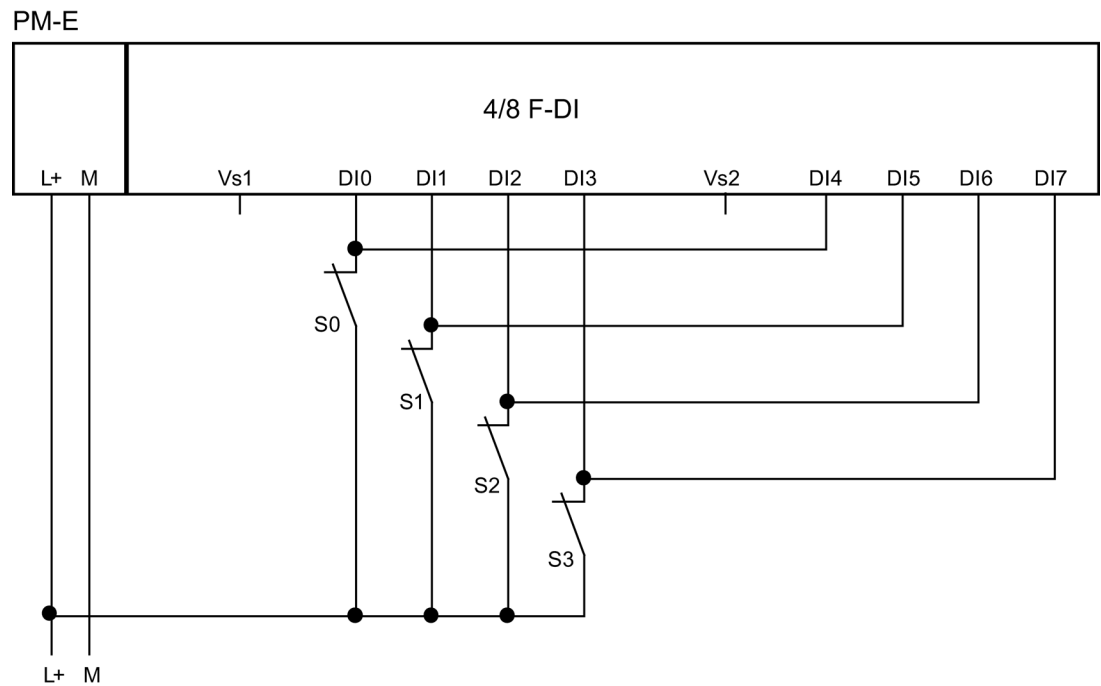

Figure 7-22 Wiring diagram EM 4/8 F-DI DC24V - one sensor connected via one channel to two inputs, external sensor supply

⚠ WARNING

To achieve SIL3/Category 3/PLe using this wiring, you must use a suitably qualified sensor.

Assignable Parameters for Application 2.1

Set the "1oo2 evaluation" at the corresponding input, and "Single-channel" at the "Type of sensor interconnection" parameter. The default discrepancy time of 10 ms cannot be modified.

You can activate or deactivate the "short-circuit test" parameter. For digital inputs connected to an external supply, set the "Sensor supply" parameter for the corresponding digital input to "external". The program will otherwise report a "short-circuit" diagnostics event if the "short-circuit test" is activated.

Specific Features of Fault Detection (Application 2.1)

The following table presents fault detection according to the sensor supply and the parameter assignment for the short-circuit test:

Table 7- 20 EM 4/8 F-DI DC24V PROFIsafe: Fault detection (application 2.1)

| Example of fault | Fault detection if ... | | |
|---|---|---|------------------------|
| | Internal sensor supply and short-circuit test are activated | Internal sensor supply and short-circuit test are deactivated | External sensor supply |
| Short-circuit in DI 0 with DI 1 | No | No | No |
| Short-circuit in DI 0 with DI 5 | No | No | No |
| P-short-circuit in DI 0 | Yes | No | No |
| M-short-circuit in DI 0 | Yes* | Yes* | No |
| Discrepancy error | Yes | Yes | Yes |
| P-short-circuit in sensor supply 1 | Yes | No | No |
| M-short-circuit in sensor supply 1, or sensor supply 2 defective | Yes | Yes | Yes |
| Short-circuit in sensor supply 1 with sensor supply 2 | Yes | No | No |
| Fault in read/test circuit | Yes | Yes | Yes |
| Supply voltage fault | Yes | Yes | Yes |
| *: Fault is detected only in case of signal corruption. In other words, the signal read differs from the sensor signal (discrepancy error). If there is no signal corruption with respect to the sensor signal, fault detection is not possible and is not required from a safety standpoint. | | | |

| |
|--|
|  WARNING |
| If the short-circuit test is disabled or cannot be enabled, the wiring between the sensor and input channel must be short-circuit-proof. |

Wiring Diagram for Application 2.2 - Connecting a Two-Channel Sensor to Two Channels

A 2-channel sensor is connected to two inputs of the F-module for each process signal (1oo2 evaluation).

The wiring is carried out on the appropriate terminal module.

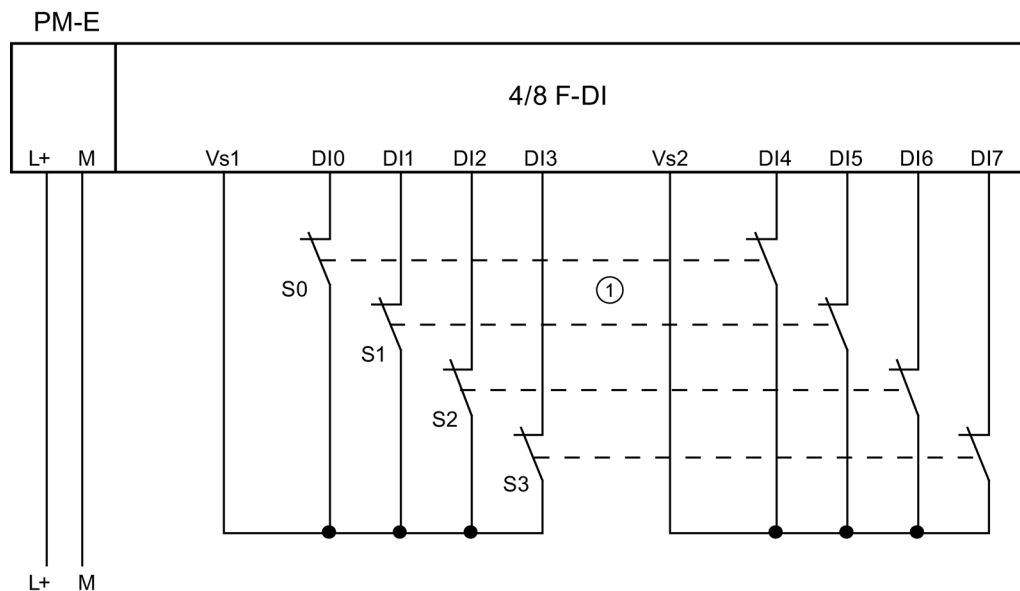

① Sensor contacts are coupled mechanically

Figure 7-23 Wiring diagram EM 4/8 F-DI DC24V - a 2-channel sensor connected via two channels, internal sensor supply

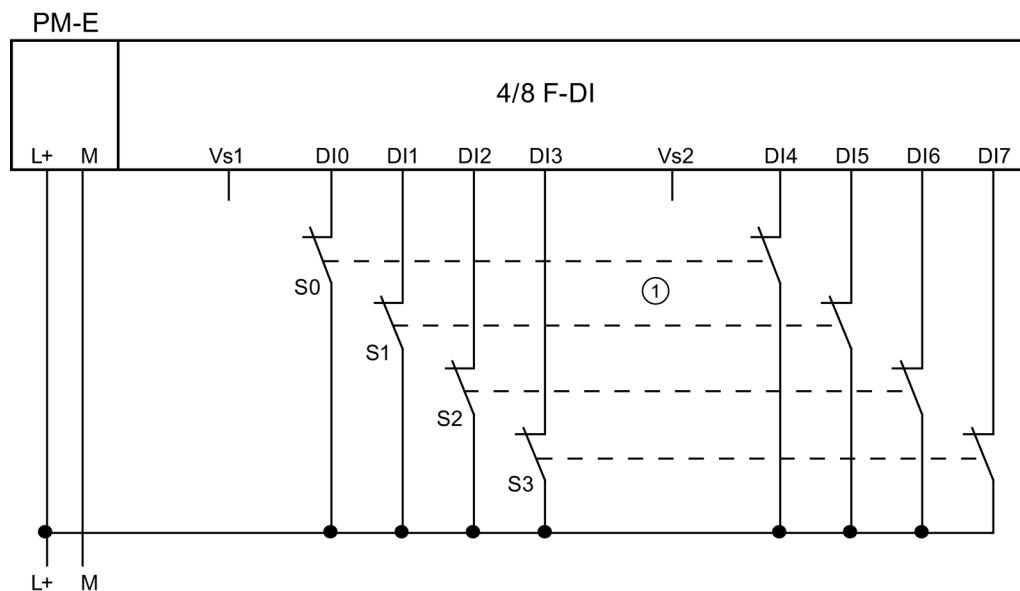

① Sensor contacts are coupled mechanically

Figure 7-24 Wiring diagram EM 4/8 F-DI DC24V - a 2-channel sensor connected via two channels, external sensor supply

Wiring Diagram for Application 2.2 – Connecting Two Single-Channel Sensors to Two Channels

Two single-channel sensors are connected via two channels to two inputs of the F-module for each process signal (1oo2 evaluation). The sensors can also be connected to an external sensor supply.

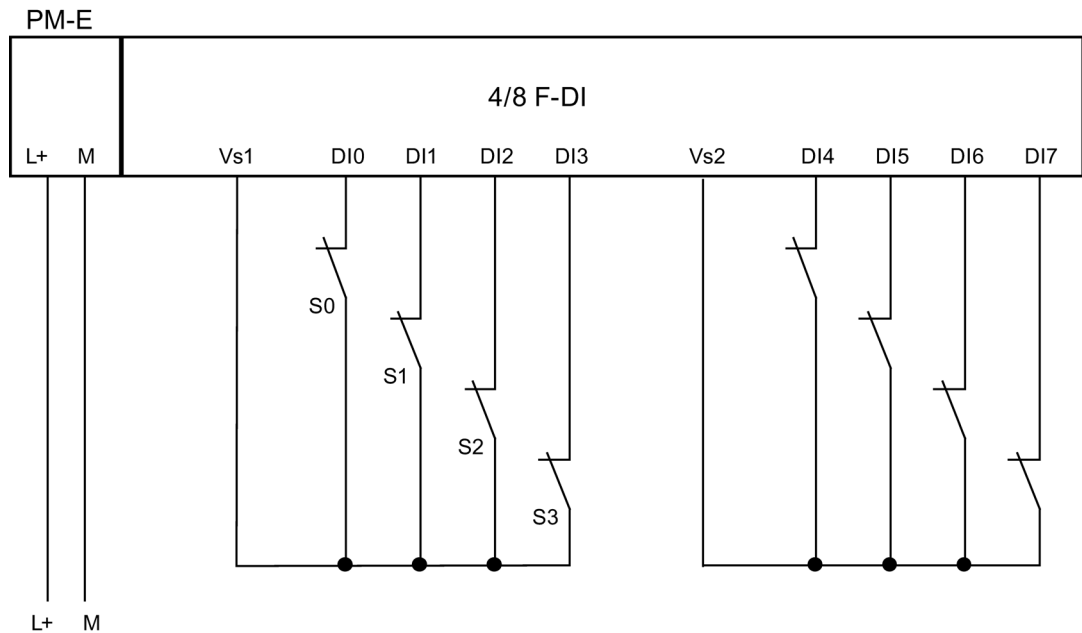

Figure 7-25 Wiring diagram EM 4/8 F-DI DC24V - two single-channel sensors connected via two channels, internal sensor supply

⚠ WARNING
 To achieve SIL3/Category 3/PLe using this wiring, you must use a suitably qualified sensor.

Assignable Parameters for Application 2.2

Set the "sensor evaluation" to "1oo2 evaluation" at the corresponding input, and "2-channel equivalent" at the "Type of sensor interconnection" parameter. Disable the "short-circuit test" parameter.

Specific Features of Fault Detection (Application 2.2)

The following table presents fault detection according to the sensor supply and the parameter assignment for the short-circuit test:

Table 7- 21 EM 4/8 F-DI DC24V PROFIsafe: Fault Detection (Application 2.2)

| Example of fault | Fault detection if ... | |
|--|---|------------------------|
| | Internal sensor supply and short-circuit test are deactivated | External sensor supply |
| Short-circuit in DI 0 with DI 1 | Yes* | Yes* |
| Short-circuit in DI 0 with DI 4 | No | No |
| Short-circuit in DI 0 with DI 5 | Yes* | Yes* |
| P-short-circuit in DI 0 | Yes* | Yes* |
| M-short-circuit in DI 0 | Yes* | Yes* |
| Discrepancy error | Yes | Yes |
| P-short-circuit in sensor supply 1 | No | No |
| M-short-circuit in sensor supply 1, or sensor supply 2 defective | Yes | Yes |
| Short-circuit in sensor supply 1 with sensor supply 2 | No | No |
| Fault in read/test circuit | Yes | Yes |
| Supply voltage fault | Yes | Yes |

*: Fault is detected only in case of signal corruption. In other words, the signal read differs from the sensor signal (discrepancy error). If there is no signal corruption with respect to the sensor signal, fault detection is not possible and is not required from a safety standpoint.

Wiring Diagram for Application 2.3 - Connecting a Non-equivalent Sensor to Two Non-equivalent Channels

A non-equivalent sensor is connected non-equivalently to two inputs of the F-module for each process signal (1oo2 evaluation).

Alternatively, two single-channel sensors can be connected non-equivalently via two channels (see figure "Wiring diagram EM 4/8 F-DI DC24V - two single-channel sensors connected non-equivalently via two channels, internal sensor supply"). In this case, the same process variable is acquired with two mechanically separate sensors.

The left-hand channels on the F-module (DI0 through DI3) supply the wanted signals. If no faults are detected, these signals will be available in the process image for inputs on the F-CPU.

Note

If you power the sensors from the F-DI module, you must use the internal sensor supply Vs1. Connection to Vs2 is not possible.

The wiring is carried out on the appropriate terminal module.

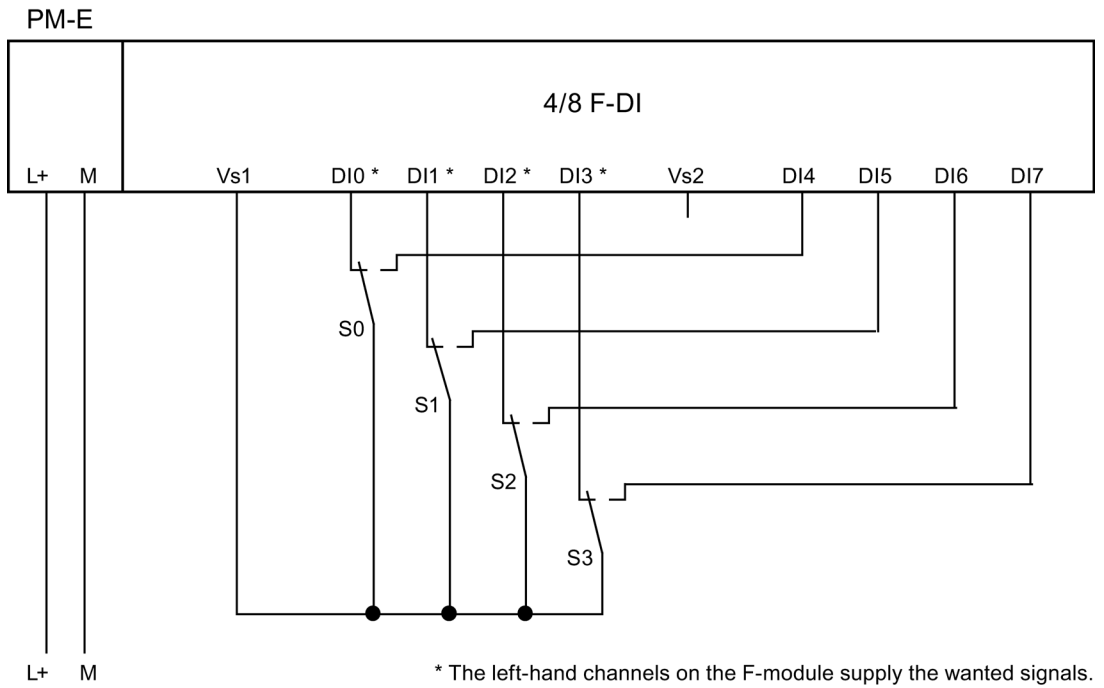

Figure 7-26 Wiring diagram EM 4/8 F-DI DC24V - a non-equivalent sensor connected non-equivalently via two channels, internal sensor supply

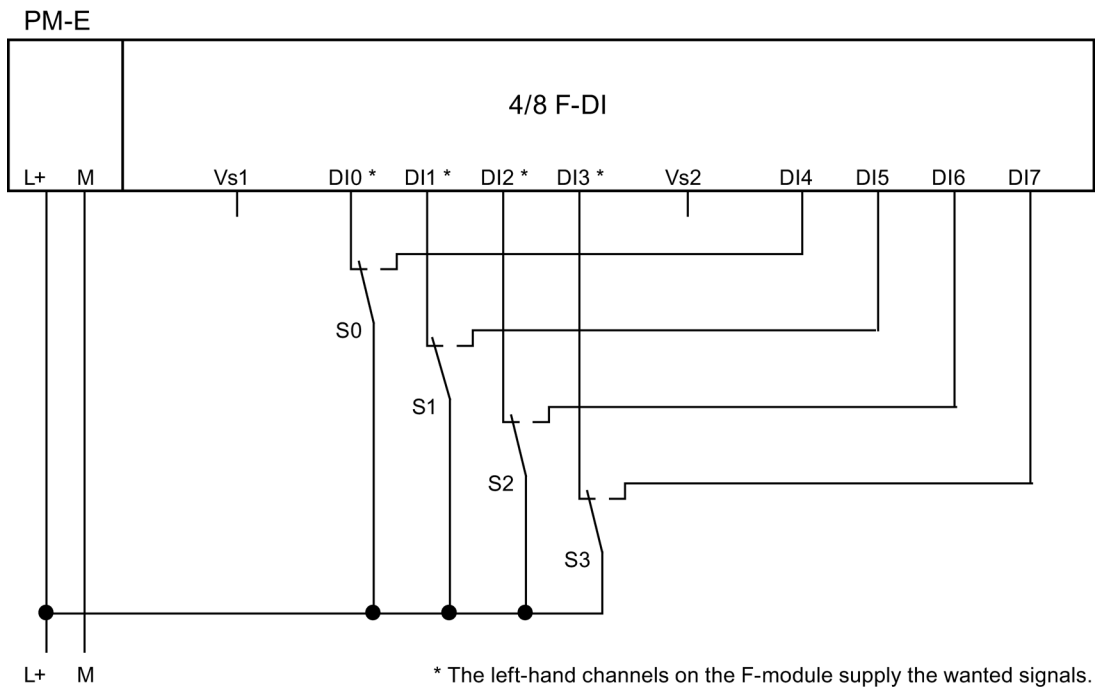

Figure 7-27 Wiring diagram EM 4/8 F-DI DC24V - a non-equivalent sensor connected non-equivalently via two channels, external sensor supply

Wiring Diagram for Application 2.3 – Connecting Two Single-Channel Sensors Non-equivalently via Two Channels

The left-hand channels on the F-module (DI0 through DI3) supply the wanted signals. If no faults are detected, these signals will be available in the I/O area for inputs on the F-CPU.

The sensors can also be connected to an external sensor supply.

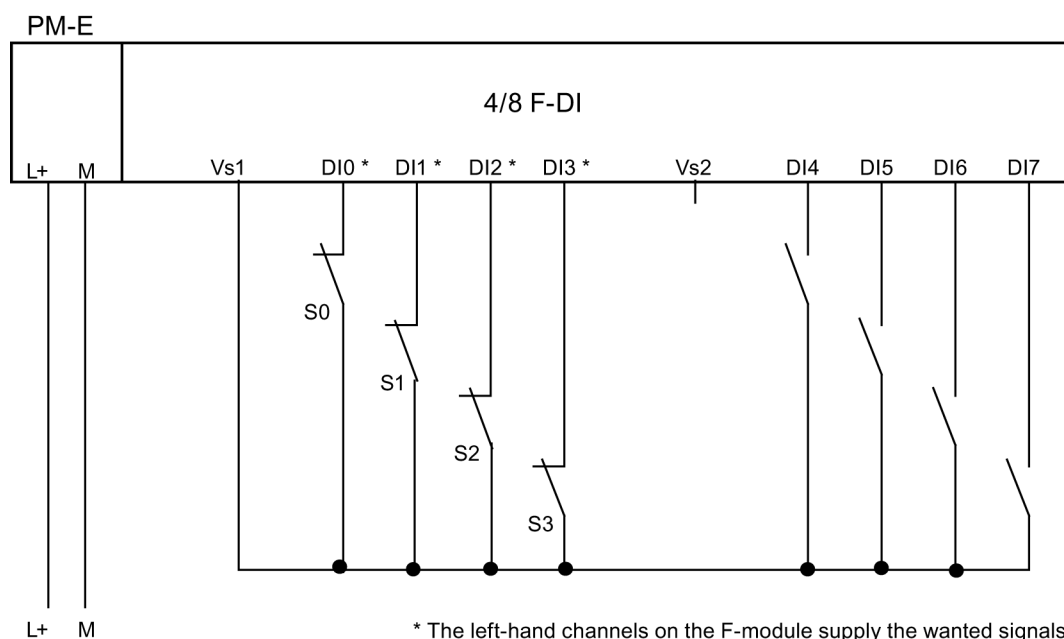



Figure 7-28 Wiring diagram EM 4/8 F-DI DC24V - two single-channel sensors connected non-equivalently via two channels, internal sensor supply

| |
|--|
|  WARNING |
| To achieve SIL3/Category 3/PLe using this wiring, you must use a suitably qualified sensor. |

Assignable Parameters for Application 2.3

Set the "sensor evaluation" to "1oo2 evaluation" at the corresponding input, and "2-channel equivalent" at the "Type of sensor interconnection" parameter. Disable the "short-circuit test" parameter.

For digital inputs connected to an external supply, set the "Sensor supply" parameter for the corresponding digital input to "external".

Specific Features of Fault Detection (Application 2.3)

The following table presents fault detection according to the sensor supply and the parameter assignment for the short-circuit test:

Table 7- 22 EM 4/8 F-DI DC24V PROFIsafe: Fault Detection (Application 2.3)

| Example of fault | Fault detection if ... | |
|--|---|------------------------|
| | Internal sensor supply and short-circuit test are deactivated | External sensor supply |
| Short-circuit in DI 0 with DI 1 | Yes* | Yes* |
| Short-circuit in DI 0 with DI 4 | Yes | Yes |
| Short-circuit in DI 0 with DI 5 | Yes* | Yes* |
| P-short-circuit in DI 0 | Yes* | Yes* |
| M-short-circuit in DI 0 | Yes* | Yes* |
| Discrepancy error | Yes | Yes |
| P-short-circuit in sensor supply 1 | No | No |
| M-short-circuit in sensor supply 1, or sensor supply 2 defective | Yes | Yes |
| Short-circuit in sensor supply 1 with sensor supply 2 | No | No |
| Fault in read/test circuit | Yes | Yes |
| Supply voltage fault | Yes | Yes |

*: Fault is detected only in case of signal corruption. In other words, the signal read differs from the sensor signal (discrepancy error). If there is no signal corruption with respect to the sensor signal, fault detection is not possible and is not required from a safety standpoint.

7.5.8 Application 3: Safety mode SIL3/Category 4/PLe

Assigning Inputs to Each Other

The EM 4/8 F-DI DC24V PROFIsafe has 8 fail-safe inputs, DI 0 through DI 7 (SIL2). A pair of these inputs can each be used as one input (SIL3). The following assignment applies:

- DI 0 with DI 4
- DI 1 with DI 5
- DI 2 with DI 6
- DI 3 with DI 7

Sensor supply

The EM 4/8 F-DI DC24V PROFIsafe provides sensor supply Vs1 for Inputs 0 to 3 and sensor supply Vs2 for Inputs 4 to 7.

Exception:

- Application 3.2, see Figure 7-31 Wiring diagram EM 4/8 F-DI DC24V - two single-channel sensors connected non-equivalently via two channels, internal sensor supply (Page 147)

The sensor must be supplied internally.

Wiring Diagram for Application 3.1 - Connecting a Two-Channel Sensor to Two Channels

A 2-channel sensor is connected to two inputs of the F-module for each process signal (1oo2 evaluation).

Alternatively, two single-channel sensors can be connected via two channels. In this case, the same process variable is acquired with two mechanically separate sensors.

The wiring is carried out on the appropriate terminal module.

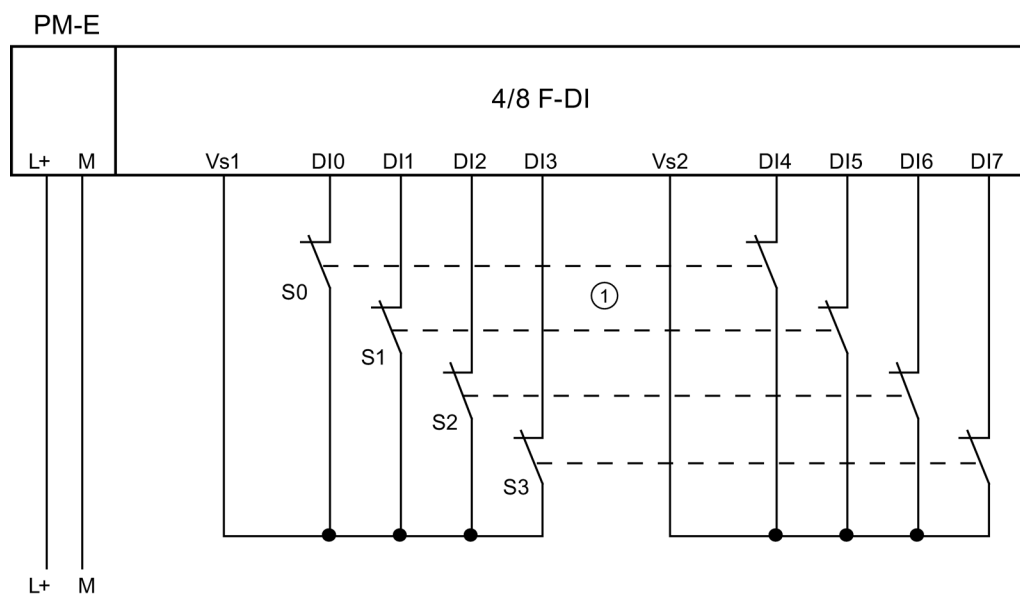

- ① Sensor contacts are coupled mechanically

Figure 7-29 Wiring diagram EM 4/8 F-DI DC24V - a 2-channel sensor connected via two channels, internal sensor supply

Alternatively, two single-channel sensors can be connected via two channels (see figure "Wiring diagram EM4/8 F-DI DC24V - two single-channel sensors connected via two channels, internal sensor supply"). In this case, the same process variable is acquired with two mechanically separate sensors.

WARNING

To achieve SIL3/Category 4/PLe using this wiring, you must use a suitably qualified sensor.

Assignable Parameters for Use Case 3.1

Set the "sensor evaluation" to "1oo2 evaluation" at the corresponding input, and "2-channel equivalent" at the "Type of sensor interconnection" parameter. Activate the "short-circuit test" parameter and set "internal" at the "sensor supply" parameter.

Wiring Diagram for Application 3.2 - Connecting a Non-equivalent Sensor to Two Non-equivalent Channels

4 process signals can be connected to an EM 4/8 F-DI DC24V PROFIsafe. A sensor is non-equivalently connected via 2 channels to two inputs of the F-module for each process signal (1oo2 evaluation).

Alternatively, two single-channel sensors can be connected via two channels (see figure "Wiring diagram EM 4/8 F-DI DC24V - two single-channel sensors connected non-equivalently via two channels, internal sensor supply"). In this case, the same process variable is acquired with two mechanically separate sensors.

The left-hand channels on the F-module (DI0 through DI3) supply the wanted signals. If no faults are detected, these signals will be available in the I/O area for inputs on the F-CPU.

Note

You must use the internal sensor supply Vs1 to supply voltage to the sensor. Connection to Vs2 is not possible.

The wiring is carried out on the appropriate terminal module.

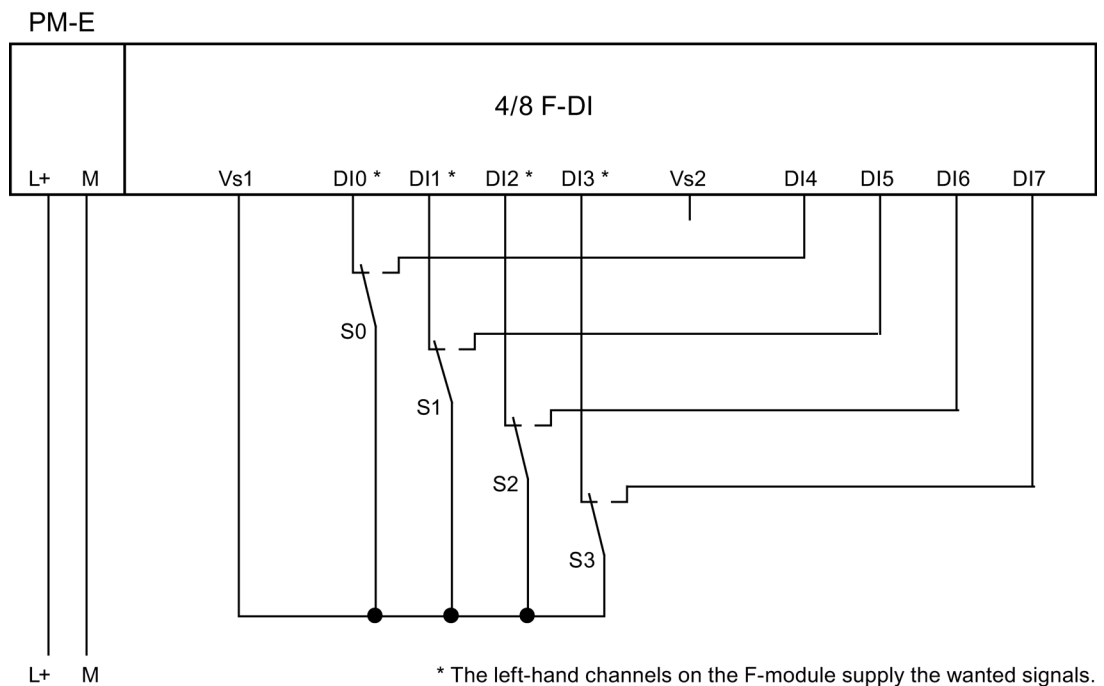

Figure 7-30 Wiring diagram EM 4/8 F-DI DC24V - a non-equivalent sensor connected via two channels non-equivalently, internal sensor supply

⚠ WARNING
 To achieve SIL3/Category 4/PLe using this wiring, you must use a suitably qualified sensor.

Wiring Diagram for Application 3.2 – Connecting Two Single-Channel Sensors Non-equivalently via Two Channels

The left-hand channels on the F-module (DI0 through DI3) supply the wanted signals. If no faults are detected, these signals will be available in the I/O area for inputs on the F-CPU.

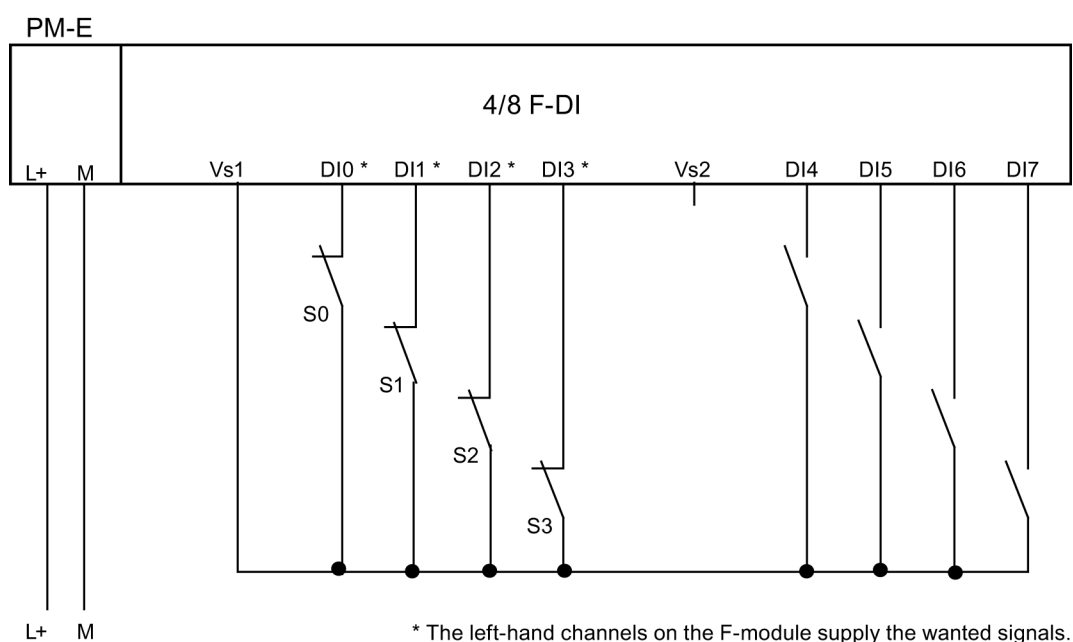

Figure 7-31 Wiring diagram EM 4/8 F-DI DC24V - two single-channel sensors connected non-equivalently via two channels, internal sensor supply

⚠ WARNING
 To achieve SIL3/Category 4/PLe using this wiring, you must use a suitably qualified sensor.

Assignable Parameters for Application 3.2

Set the "sensor evaluation" parameter to "1oo2 evaluation" at the corresponding input, and "2-channel non-equivalent" at the "Type of sensor interconnection" parameter. Activate the "short-circuit test" parameter and set "internal" at the "sensor supply" parameter.

Special Features for Fault Detection (Applications 3.1 and 3.2)

The following table presents fault detection according to the sensor supply and the parameter assignment for the short-circuit test:

Table 7- 23 EM 4/8 F-DI DC24V PROFIsafe: Fault Detection (Applications 3.1 and 3.2)

| Example of fault | Fault detection with internal sensor power supply and activated short-circuit test for... | |
|---|---|---------------------------------|
| | Sensor 2-channel equivalent | Sensor 2-channel non-equivalent |
| Short-circuit in DI 0 with DI 1 | Yes* | Yes* |
| Short-circuit in DI 0 with DI 4 | Yes* | Yes |
| Short-circuit in DI 0 with DI 5 | Yes* | Yes* |
| P-short-circuit in DI 0 | Yes | Yes |
| M-short-circuit in DI 0 | Yes* | Yes* |
| Discrepancy error | Yes | Yes |
| P-short-circuit in sensor supply 1 | Yes | Yes |
| M-short-circuit in sensor supply 1, or sensor supply 2 defective | Yes | Yes |
| Short-circuit in sensor supply 1 with sensor supply 2 | Yes | Yes |
| Fault in read/test circuit | Yes | Yes |
| Supply voltage fault | Yes | Yes |
| *: Fault is detected only in case of signal corruption. In other words, the signal read differs from the sensor signal (discrepancy error). If there is no signal corruption with respect to the sensor signal, fault detection is not possible and is not required from a safety standpoint. | | |

Requirements for Machine Protection Use Cases with Category 4

The following requirements apply for applications in machine protection with category 4:

- The wiring between sensors and automation system and between automation system and actuators must be designed to state-of-the-art engineering and standards to prevent short-circuits
- All short-circuits listed in the above table are covered. It is sufficient to locate a short-circuit, because two faults are required for it to occur (both signal lines in short-circuit have an insulation fault). A multiple short-circuit analysis is not required.

Procedures for locating all short-circuits are also permissible if single short-circuits are not located,

- provided these do not cause corruption of read signals compared to the sensor signals or
- provided they cause corruption of read signals compared to sensor signals in the direction that ensures safety.

7.5.9 Diagnostic functions of EM 4/8 F-DI DC24V PROFIsafe

Behavior in Case of Supply Voltage Failure

Failure of the Vs1 and Vs2 sensor power supply of the EM 44/8 F-DI DC24V PROFIsafe is indicated by the 1VsF and 2VsF LED on the F-module. This information is also provided in the module (diagnostic entry). Either all channels of the module are passivated or, in the case of channel-specific passivation, the relevant channels are passivated.

In the case of a voltage dip in the external auxiliary voltage, the SF LED lights up, the module is passivated.

With the subsequent supply recovery (level must remain above the specified value for at least 1 minute (refer to the technical specifications: voltages, currents, electrical potentials)) the SF LED goes out again, the module remains passivated. The SF LED flashes if there are no other errors, until the error is acknowledged.

Behavior in Case of Cross-Circuit/Short-Circuit at the Sensor Supply

When operating with programmed external sensor supply and blocked short-circuit test, you enable the detection of short-circuits to M at the sensor supplies and signaling at the corresponding VsFLED. No entries are made in the diagnostics data of the module.

When operating with a configured external sensor supply and cyclic short-circuit test, you enable the detection of cross-circuits between 1Vs and 2Vs and short-circuits to M and P at the sensor supplies and signaling at the corresponding VsF LED. No entries are made in the diagnostics data of the module.

Diagnostic Functions

The table below provides an overview of the diagnostic functions of the EM 4/8 F-DI DC24V PROFIsafe. The diagnostic functions are assigned either to one channel or to the entire module.

Table 7- 24 Diagnostic functions of the EM 4/8 F-DI DC24V PROFIsafe

| Diagnostic function* | Fault number | LED | is signaled in application | Effective range of diagnostics | programmable |
|--|-----------------|--------------------|----------------------------|--------------------------------|--------------|
| Short-circuit | 1 _H | SF 1VsF 2VsF | 1, 2, 3 | Channel | Yes |
| Overtemperature | 5 _H | SF | 1, 2, 3 | Module | No |
| Fault | 9 _H | SF | 1, 2, 3 | Module | No |
| Parameter assignment error | 10 _H | SF | 1, 2, 3 | Module | No |
| Sensor voltage or load voltage missing | 11 _H | SF | 1, 2, 3 | Module | No |
| Communication error | 13 _H | SF | 1, 2, 3 | Module | No |

| Diagnostic function* | Fault number | LED | is signaled in application | Effective range of diagnostics | programmable |
|--|--------------|-----|----------------------------|--------------------------------|--------------|
| Safety-related shutdown <ul style="list-style-type: none"> Discrepancy error (1002 evaluation) | 19H | SF | 2.3 | Channel | No |
| *: special for fail-safe modules; display in <i>STEP 7</i> , see Table 5-1 Fault types of channel-related diagnostics (apart from EM 1 F-RO DC24V/AC24..230V/5A) (Page 58) | | | | | |

Special Features for Fault Detection

The detection of certain faults (short-circuits or discrepancy errors, for example) depends on the application, the wiring, and the parameter assignment of the short-circuit test and the sensor power supply. For this reason, tables on fault detection for the applications are presented in "Use Case 1: Safety mode SIL2/Category 3/PLd" to "Use case 3: Safety mode SIL3/Category 4/PLe".

Causes of Faults and Corrective Measures

The following table contains the possible causes of faults and their corrective measures for the individual diagnostic messages and diagnostic buffer entries of electronic module 4/8 F-DI DC24V PROFIsafe.

Table 7- 25 Diagnostic messages and diagnostic buffer entries of the EM 4/8 F-DI DC24V PROFIsafe, causes of errors and remedies

| Diagnostic Message | Diagnostics buffer | Possible Causes | Corrective Measures |
|--------------------|---|---|--|
| Short-circuit | Short-circuit to L+ of sensor supply | Sensor line short-circuited with sensor supply | Eliminate the short-circuit |
| | | Sensor is defective | Replace the sensor |
| | | Internal error | Replace module |
| | Ground-short-circuit or defective sensor supply | Short-circuit between two sensor lines | Eliminate the short-circuit |
| | | Short-circuit between two sensor supplies | Eliminate the short-circuit Check "Sensor supply" parameter |
| | | Short-circuit between input and sensor supply of another channel | Eliminate the short-circuit |
| | | Electromagnetic interference has exceeded limits | Eliminate the interference, reduce the interference |
| | | Internal error | Replace module |
| | Internal error in read/test circuit | Several fault messages exist for the channel. Faults cannot be clearly assigned | Eliminate causes of fault |
| | | Internal error | Replace module |

| Diagnostic Message | Diagnostics buffer | Possible Causes | Corrective Measures |
|--|--|--|---|
| Overtemperature | Temperature outside the permitted range | Shutdown due to violation of high or low temperature limit value in the module case. | Check the ambient temperature. Once the fault has been eliminated, the module must be removed and inserted or the power switched off and on |
| Fault | Processor failure | Electromagnetic interference has exceeded limits | Eliminate the interference. Once the fault has been eliminated, the module must be removed and inserted or the power switched off and on. |
| | | Internal error | Replace module |
| | | Setting of the address switch (DIP switch) not as expected | Check and correct DIP switch settings |
| | Processor error | Electromagnetic interference has exceeded limits | Eliminate the interference. Once the fault has been eliminated, the module must be removed and inserted or the power switched off and on. |
| | | Internal error | Replace module |
| | EPROM fault | Electromagnetic interference has exceeded limits | Eliminate the interference. Once the fault has been eliminated, the module must be removed and inserted or the power switched off and on. |
| | | Internal error | Replace module |
| | RAM fault | Electromagnetic interference has exceeded limits | Eliminate the interference. Once the fault has been eliminated, the module must be removed and inserted or the power switched off and on. |
| | | Internal error | Replace module |
| | Time monitoring activated | PROFIsafe monitoring time set too low | Set a higher value for the "F monitoring time" parameter for the module |
| Parameter assignment error | Parameter assignment error (19, 20, 21) | Faulty parameter assignment | Check communication paths Correct the parameters |
| | Parameter assignment error (18) | PROFIsafe address set incorrectly in the F-module | Check whether the PROFIsafe address on the fail-safe module matches the configuration |
| Sensor voltage or load voltage missing | Internal supply voltage of the module failed | Electromagnetic interference has exceeded limits | Eliminate the interference. Once the fault has been eliminated, the module must be removed and inserted or the power switched off and on. |
| | | Internal supply voltage error | Replace module |

| Diagnostic Message | Diagnostics buffer | Possible Causes | Corrective Measures |
|-------------------------|---|--|---|
| Communication error | Cyclic redundancy check (CRC) error in data message frame | Communication interference between the F-CPU and the fail-safe module, e.g., due to electromagnetic interference in excess of limits or sign-of-life monitoring error. | Check the PROFIBUS/PROFINET connection Eliminate the interference |
| | | Write access to the I/O area for module inputs and outputs in the standard user program. | Remove the write accesses to the I/O area for module inputs and outputs of the F-module in the standard user program. |
| | Monitoring time for data message frame exceeded | Assigned monitoring time exceeded | Check the monitoring time parameter assignment |
| Safety-related shutdown | Discrepancy error, channel status 0/0 | Process signal faulty, sensor may be defective | Check process signal, replace sensor if necessary |
| | Discrepancy error, channel status 0/1 | Assigned discrepancy time too short | Check the configured discrepancy time |
| | Discrepancy error, channel status 1/0 | Short-circuit between unconnected sensor cable and the sensor supply cable | Check the wiring |
| | Discrepancy error, channel status 1/1 | Wire break in connected sensor cable or the sensor supply cable | |
| | | | Once the fault is eliminated, the F-module must be reintegrated in the safety program |

You can find detailed information on F I/O passivation and reintegration under *"Diagnostics"* in the *S7 Distributed Safety, Configuring and Programming* manual or the *S7 F/FH Systems, Configuring and Programming* manual.

Generally Applicable Information on Diagnostics

For information on diagnostics that affects all fail-safe modules (such as readout of diagnostic functions; passivation of channels) see this manual in *"Diagnostics"* and the *S7 Distributed Safety, Configuration and Programming* manual or *S7 F/FH Systems, Configuring and Programming*.

See also

Fault Diagnostics (Page 55)

7.5.10 Technical Specifications of the EM 4/8 F-DI DC24V PROFIsafe

Overview

| Technical specifications | | |
|---|---|------------|
| Dimensions and weight | | |
| Dimensions W x H x D (mm) | 30 x 81 x 52 | |
| Weight | Approx. 78 g | |
| Data for Specific Module | | |
| Number of inputs | | |
| • 1-channel | 8, maximum | |
| • 2-channel | 4, maximum | |
| Assigned address area | | |
| • I/O area for inputs | 6 bytes | |
| • I/O area for outputs | 4 bytes | |
| Length of cable | | |
| • Unshielded * | Max. 500 m (at input delay 3 ms * and 15 ms) | |
| • Shielded * | Max. 500 m (at input delay 0.5 ms, 3 ms and 15 ms) | |
| Maximum achievable safety class | 1-channel | 2-channel |
| • in accordance with IEC 61508:2000 | SIL2 | SIL3 |
| • in accordance with ISO 13849-1:2006 or EN ISO 13849-1:2008 | Cat.3/PLd | Cat.4/PLe |
| Safety characteristics | SIL2 | SIL3 |
| • Low demand mode (average probability of failure on demand) | < 1.00E-03 | < 1.00E-05 |
| • High demand/continuous mode (probability of a dangerous failure per hour) | < 1.00E-08 | < 1.00E-10 |
| • Acceptance ID | FM, cULus, ATEX, CE, C-Tick | |
| Voltages, Currents, Potentials | | |
| Rated supply voltage L+ | 24 VDC | |
| • permissible range ** | 20.4 V to 28.8 V | |
| • Power loss ride-through of L+ | None | |
| • Mains buffering of internal voltage supply | 5 ms | |
| • Reverse polarity protection | No | |

| Technical specifications | |
|--|---|
| Number of simultaneously controllable inputs | |
| <ul style="list-style-type: none"> • Horizontal installation <ul style="list-style-type: none"> – Up to 55 °C – Up to 60 °C – Up to 60 °C | 8 (with 28.8 V) 8 (with 24 V) 6 (with 28.8 V) |
| <ul style="list-style-type: none"> • Vertical installation <ul style="list-style-type: none"> – Up to 40 °C | 8 |
| Electrical isolation | |
| <ul style="list-style-type: none"> • Between channels and backplane bus | Yes |
| <ul style="list-style-type: none"> • Between channels and power supply | No |
| <ul style="list-style-type: none"> • Between channels | No |
| <ul style="list-style-type: none"> • Between channels/power supply and shield | Yes |
| Permissible potential difference between | |
| <ul style="list-style-type: none"> • Shield and ET 200S bus connection | 75 V DC/60 V AC |
| <ul style="list-style-type: none"> • Shield and I/O (DIs, P1/P2 buses) | 75 V DC/60 V AC |
| <ul style="list-style-type: none"> • ET 200S bus connection and I/O (DIs, P1/P2 buses) | 250 V AC |
| Isolation in the series tested with | |
| <ul style="list-style-type: none"> • ET 200S bus connection against I/O (DIs, P1/P2 buses) | 2545 V DC/2 s |
| Isolation in the type test tested with | |
| <ul style="list-style-type: none"> • Shield and ET 200S bus connection | 350 V AC/1 min |
| <ul style="list-style-type: none"> • Shield and I/O (DIs, P1/P2 buses) | 350 V AC/1 min |
| <ul style="list-style-type: none"> • ET 200S bus connection and I/O (DIs, P1/P2 buses) | 2830 V AC/1 min |
| <ul style="list-style-type: none"> • Surge voltage test between ET 200S bus connection and I/O (DIs, P1/P2 bus) | 6000 V DC/5 positive and 5 negative pulses |
| Current consumption | |
| <ul style="list-style-type: none"> • From backplane bus | 28 mA, typical |
| <ul style="list-style-type: none"> • From load voltage L+ (without load) | 120 mA, typical |
| Power loss of the module | 4 W, typical |
| Status, interrupts, diagnostics | |
| Status display | |
| Inputs | Green LED per channel |
| Sensor supply | Red LED per channel |
| Diagnostic functions | |
| <ul style="list-style-type: none"> • Group fault display | Red LED (SF) |
| <ul style="list-style-type: none"> • Diagnostic information can be displayed | Possible |

| Technical specifications | | |
|--|--|--------------------|
| Sensor Supply Outputs | | |
| Number of outputs | 2 | |
| Output voltage | | |
| • Loaded | Minimum L+ (-1.5 V) | |
| Output current | | |
| • Rated value | 300 mA | |
| • Permissible range | 0 mA to 300 mA | |
| Permissible total current of outputs | 600 mA | |
| Short-circuit protection | Yes, electronic | |
| • Operating value | 0.7 A to 1.8 A | |
| Data for selecting a sensor *** | | |
| Input voltage | | |
| • Rated value | 24 VDC | |
| • For "1" signal | 15 V to 30 V | |
| • For "0" signal | -30 V to 5 V | |
| Input current | | |
| • For "1" signal | 3.7 mA, typical | |
| Input delay * | Assignable (for all inputs together) | |
| • For "0" after "1" | Typically 0.5 ms | (0.3 ms to 0.7 ms) |
| | Typically 3 ms | (2.6 ms to 3.4 ms) |
| | Typically 15 ms | (13 ms to 17 ms) |
| • For "1" after "0" | Typically 0.5 ms | (0.3 ms to 0.7 ms) |
| | Typically 3 ms | (2.6 ms to 3.4 ms) |
| | Typically 15 ms | (13 ms to 17 ms) |
| Input characteristic | In accordance with IEC 61131-2 Type 1 | |
| Connection of 2-wire proximity switch | Not possible | |
| • Permissible quiescent current | 0.6 mA, maximum | |
| Time, Frequency | | |
| Internal processing times | See "Response times" | |
| Acknowledgment time in safety mode | | |
| • Short-circuit test activated | Min. 4 ms / max. 7 ms | |
| With input delay of 0.5 ms: | Min. 4 ms / max. 12 ms | |
| With input delay of 3 ms: | Min. 4 ms / max. 9 ms | |
| With input delay of 15 ms: | | |
| • Short-circuit test deactivated | Min. 4 ms / max. 6 ms | |
| Minimum sensor signal duration | See "Minimum Duration of Sensor Signals to Allow Correct Detection by the F-DI Module" table in "Wiring and Fitting Modules" | |

| Technical specifications | |
|--|-------------------|
| Protection against overvoltage | |
| Protection of power supply L+ from surge in accordance with IEC 61000-4-5 with external protection elements only | |
| • Symmetrical (L+ to M) | + 1 kV; 1.2/50 µs |
| • Asymmetrical (L+ to PE, M to PE) | + 2 kV; 1.2/50 µs |
| Protection of inputs and outputs from surge in accordance with IEC 61000-4-5 with external protection elements only | |
| • Symmetrical (Vs, DI to M) | +1 kV; 1.2/50 µs |
| • Asymmetrical (Vs, DI to PE, M to PE) | +1 kV; 1.2/50 µs |
| <p>*: With an input delay of 0.5 ms, shielded cables must be used for the digital inputs and the sensor supply. With 3 ms input delay, shielded cables must be used if there is a danger of overvoltage on the signal lines (see section "Electromagnetic Compatibility") to prevent possible passivation of the fail-safe digital inputs and the sensor power supply switching off. If unshielded signal lines are used, the safe behavior of the process variables is ensured.</p> <p>** : Operating below the permissible supply voltage is only permissible for the repair time. See section "Introduction (Page 75)".</p> <p>Operating above the permissible supply voltage can damage the fail-safe module because of the increased power loss (reduced service life). If an input becomes defective because of this, the fail-safe module reports the safe state of the input (passivation). At a supply voltage > 35.5 V, the module switches off.</p> <p>***: For more information on the requirements for encoders and actuators, refer to the section "Wiring and Fitting Modules (Page 45)".</p> | |

7.6 EM 4 F-DI/3 F-DO DC24V PROFIsafe digital electronic module

7.6.1 Properties of the 4 F-DI/3 F-DO DC24V PROFIsafe Digital Electronic Module

Order Number

6ES7138-4FC01-0AB0

Properties

The 4 F-DI/3 F-DO DC24V PROFIsafe digital electronic module possesses the following properties:

- Achievable safety class SIL2/Category 3/PLd
- Inputs
 - Four inputs
 - 24 VDC rated input voltage
 - Suitable for switches and 3/4-wire proximity switches
 - 1 short-circuit-proof sensor supply for four inputs
 - External sensor supply possible
 - The fault display for the sensor supply (VsF) is mapped to VsF and to the associated channels
 - Only 1oo2 evaluation possible
- Outputs
 - 3 outputs, P/M-switching
 - Output current 2 A
 - Rated load voltage 24 VDC
 - Suitable for solenoid valves, DC contactors and indicator lights
- Group fault display (SF; red LED)
- Status and fault LEDs for each input/output (two-color green/red LED)
- Only supported in safety mode

Supported Interface Modules

Refer to section "Using fail-safe ET 200S modules (Page 16)" for the supported interface modules.

The EM 4 F-DI/3 F-DO DC24V PROFIsafe can be used centrally with IM 151-7 F-CPU 6ES7151-7FA20-0AB0 V2.6 or higher or IM 151-8 PN/DP F-CPU 6ES7151-8FB00-0AB0.

Supported Power Modules

Table 7- 26 EM 4F-DI/3F-DO DC24V PROFIsafe: Power module for SIL/Category/PL

| Power Module | achievable SIL/Category/PL |
|--|---|
| Supply through PM-E DC24V, PM-E DC24..48V/AC24..230V or PM-E DC24..48V | with 1oo2 sensor evaluation of the SIL2/Category 3/PLd sensor |

Switching Grounded Loads

If the EM 4 F-DI/3 F-DO DC24V PROFIsafe switches loads that have a chassis-ground connection (for example to improve EMC characteristics) **and** if chassis and ground are connected at the power supply being used, a "short-circuit" is detected.

From the perspective of the F-module, the M-switch is bridged by the chassis-ground connection (refer to the diagram below as an example of an EM 4 F-DI/3 F-DO DC24V PROFIsafe).

Remedy:

- Using the PM-E F pp DC24V PROFIsafe
- The value of the resistance between chassis and ground at the load end must be greater than 100 kΩ

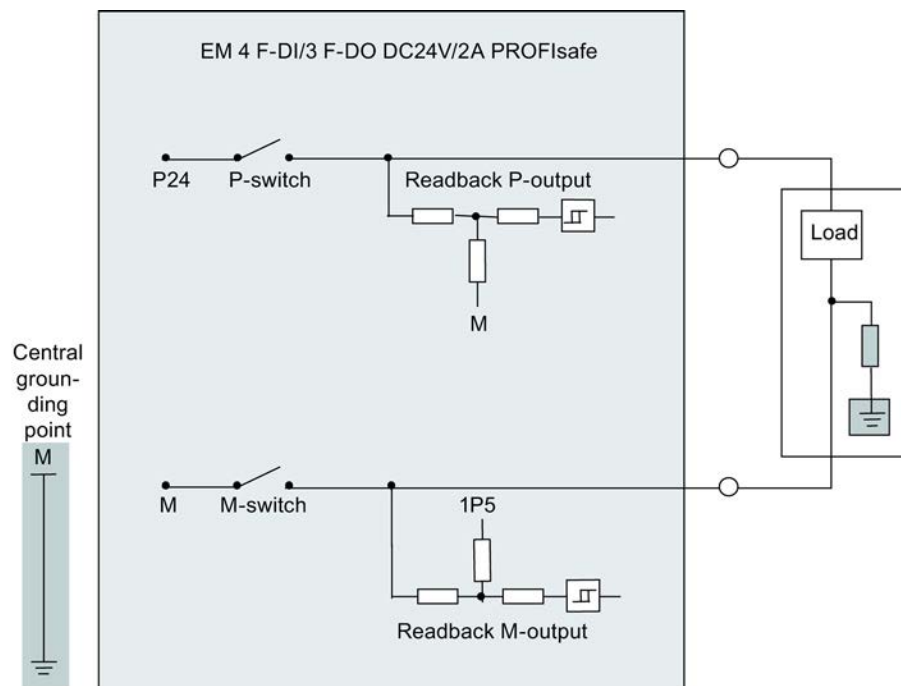

Figure 7-32 Switching Grounded Loads (resistance exists between chassis and ground)

Capacitive Crosstalk of Digital Input/Output Signals

refer to "*Properties of the power module PM-E F pm DC24V PROFIsafe*".

Magnetic crosstalk with inductive loads

Note

Note that an inductive load connected to the DO channels can induce voltages in the case of electromagnetic interference of a strong magnetic field. This can cause a short-circuit error message.

Remedy:

- Spatially disconnect the inductive loads or shield against the magnetic field.
- Set the parameters for the readback time to 50 ms or higher.

SIL mode in grounded configuration

| |
|--|
|  WARNING |
| <p>The bridging resistance between the M-output and PE may not be less than 100 kΩ for SIL2 operation in grounded configurations. The bridging impedance must be sufficiently high for underflow of the relay release voltage, in order to maintain the proper functioning of both shutdown circuits (P and M-switch).</p> |

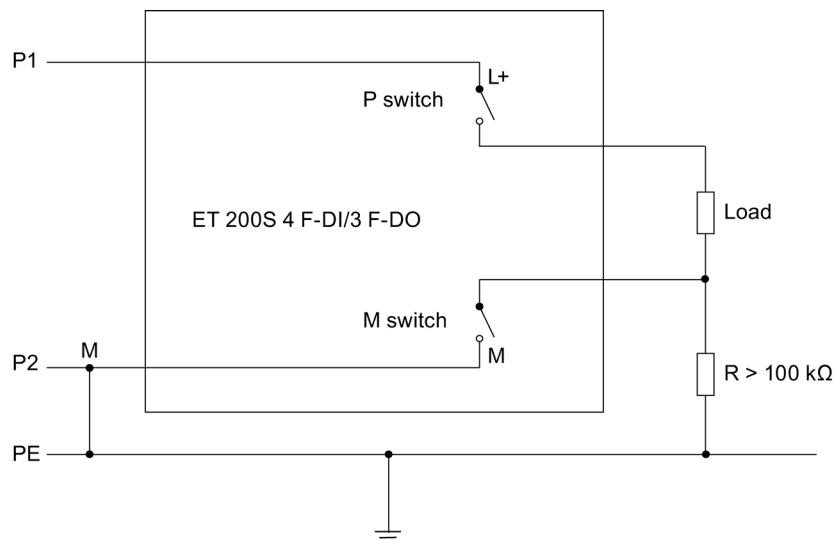

Figure 7-33 SIL2 mode in grounded configuration

7.6.2 Terminal assignment of the EM 4 F-DI/3 F-DO DC24V PROFIsafe

Front view

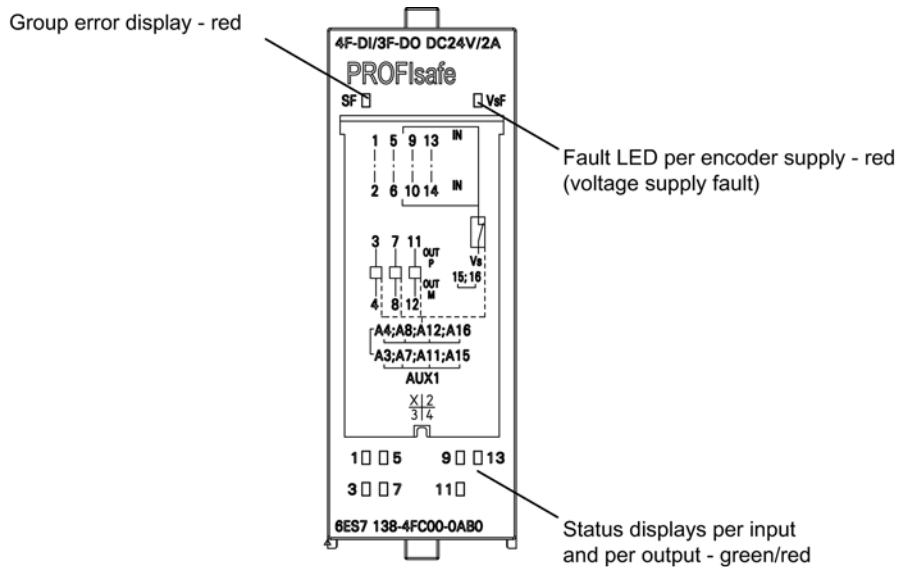

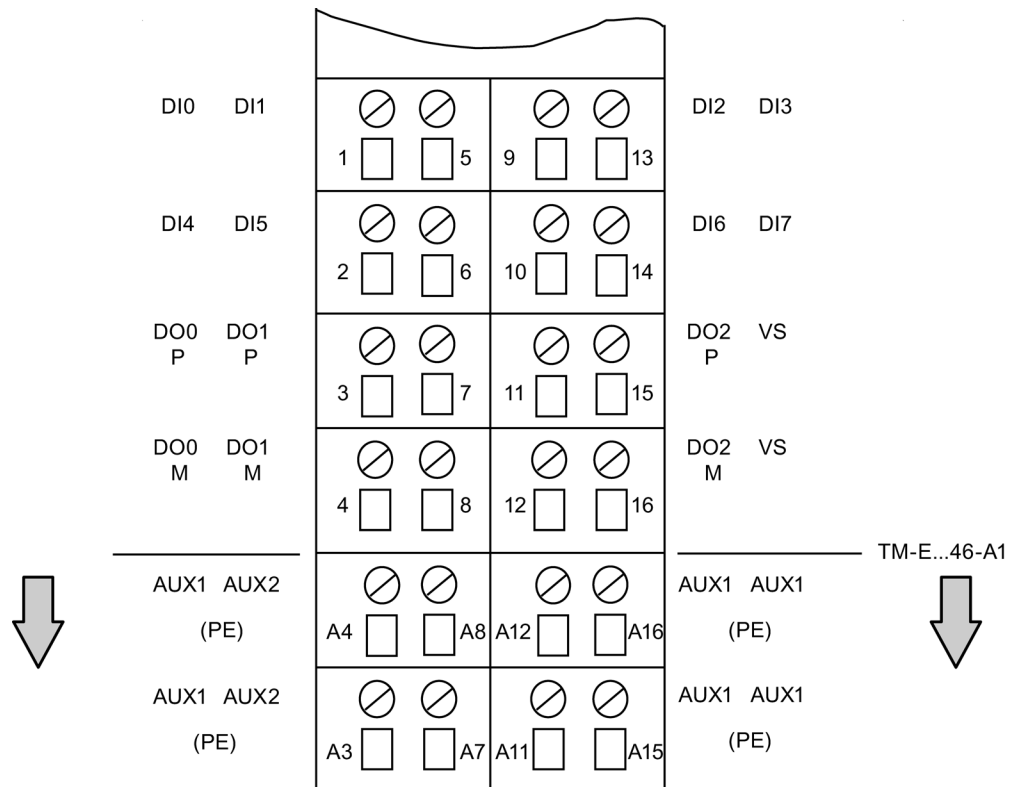

Figure 7-34 Front view 4F-DI/3F-DO

| |
|--|
|  WARNING |
| The SF LED and the status displays of the inputs/outputs are not designed for safety-related functions and may therefore not be evaluated for safety-related activities. |

Terminal assignment

The figure below shows the terminal assignment of the EM 4 F-DI/3 F-DO DC24V PROFIsafe for the terminal module TM-E30S44-01, TM-E30C44-01, TM-E30S46-A1 and TM-E30C46-A1.



- DI Fail-safe digital input
- VS Internal sensor supply for DI0 to DI7
- DOx P Terminal for fail-safe digital output (P/M-switching)
- DOx M Terminal for fail-safe digital output (P/M-switching)

For TM-E...46-A1 AUX1 bus carried out. Connection to terminals A3 to A16 for any connection of PE (individual grouping of load current power supplies possible)

Figure 7-35 Terminal assignment TM-E...44-01/TM-E...46-A1 for EM 4 F-DI/3 F-DO DC24V PROFIsafe

7.6.3 Wiring of the EM 4 F-DI/3 F-DO DC24V PROFIsafe

Block Diagram

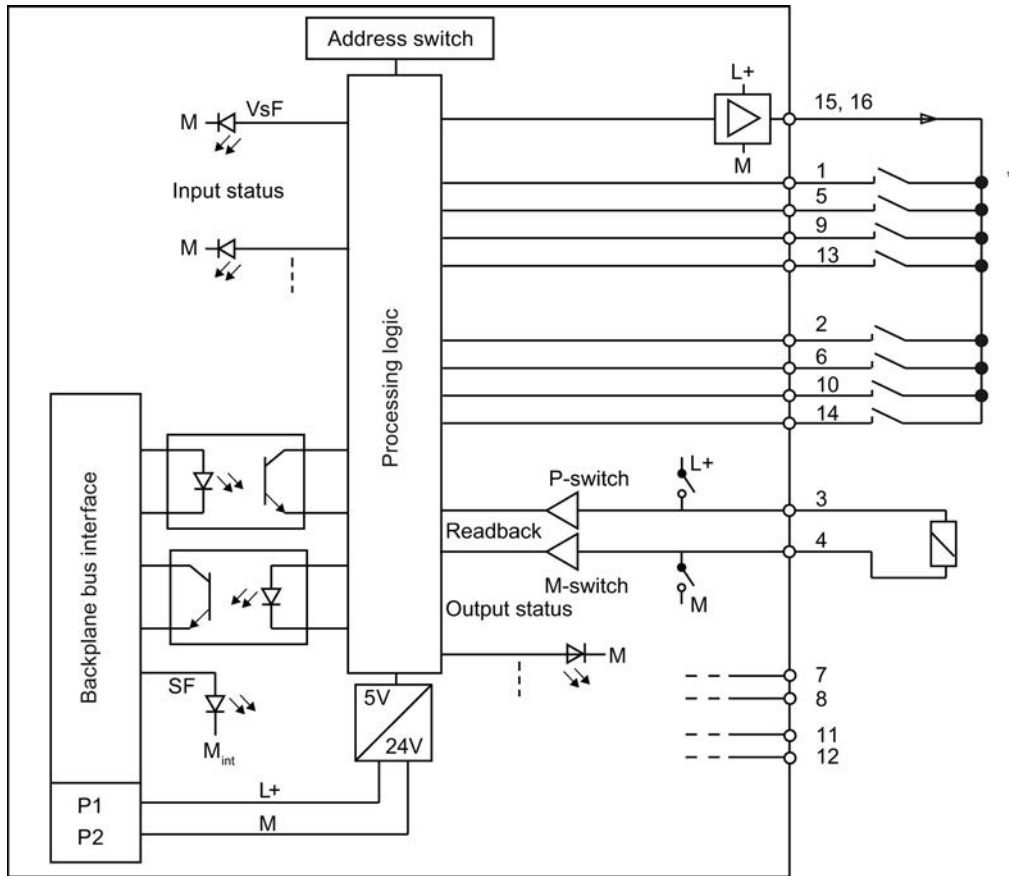

* The representation of NO contacts matches the module labeling. Usually, NC or NO combinations are used as sensor contacts (to ensure the safe state of process variables).

Figure 7-36 Block Diagram of the EM 4F-DI/3 F-DO DC24V PROFIsafe

7.6.4 EM 4 F-DI/3 F-DO DC24V PROFIsafe parameters

Parameters in *STEP 7*

The table below lists the parameters that can be set for the EM 4 F-DI/3 F-DO DC24V PROFIsafe.

Table 7- 27 Parameters of the EM 4 F-DI/3 F-DO DC24V PROFIsafe

| Parameter | Range | Default | Type of Parameter | Effective Range |
|--|---|-------------------------------|-------------------|-----------------|
| F-Parameters: | | | | |
| F_destination_address | 1 to 1022 | is assigned by <i>STEP 7</i> | Static | Module |
| F monitoring time | 10 to 10000 ms | 150 ms | Static | Module |
| Module-specific input parameters | | | | |
| Short-circuit test | Cyclic/disabled | Cyclic | Static | Module |
| Behavior after channel faults* | Passivate the entire module/Passivate the channel | Passivate the entire module | Static | Module |
| Channel n, n+4 | Activated/deactivated | Activated | Static | Channel group |
| Sensor supply | internal/external | internal | Static | Channel group |
| Sensor evaluation | 1oo2 evaluation | 1oo2 evaluation | Static | Channel group |
| Type of sensor interconnection | 1-channel 2-channel equivalent; 2-channel, non-equivalent | 2-channel equivalent | Static | Channel group |
| Behavior of discrepancy | Provide last valid value; provide 0 value | Provide last valid value | Static | Channel group |
| Discrepancy time | 10 to 30000 ms | 10 ms | Static | Channel group |
| Reintegration after discrepancy error | Zero signal test not required/Zero signal test required | Zero signal test not required | Static | Channel group |
| Module-specific output parameters: | | | | |
| Behavior after channel faults* | Passivate the entire module/Passivate the channel | Passivate the entire module | Static | Module |
| DO channel n | Activated/deactivated | Activated | Static | Channel |
| Readback time | 1 to 400 ms | 1 ms | Static | Channel |
| * This setting is only relevant when <i>S7 Distributed Safety V5.4</i> or higher is installed. | | | | |

Short-circuit test parameter

This parameter can be used to activate short-circuit detection for channels set up for "internal sensor supply."

The short-circuit test is only useful when operating with simple switches which are not connected to their own power supply.

Short-circuit detection temporarily cuts off the sensor supply. The cut-off period equals the input delay (= 3 ms) (see also "*Applications for the 4 F-DI/3 F-DO DC24V PROFIsafe electronic module*").

Sensor Supply Parameter

This parameter can be used to activate the "internal sensor supply" of the F-module. This setting is a prerequisite for using the short-circuit test.

Note

When there are different sensor supply parameter settings (internal/external) for the individual channel groups, the applications shown in the next chapter apply to specific channel groups.

Discrepancy behavior parameter

For "Behavior of Discrepancy" you assign the value that is to be made available to the safety program in the F-CPU during the time that a discrepancy exists between two input channels, i.e., when the discrepancy time is running. To program discrepancy behavior:

- "Provide last valid value" or
- "Provide 0 value"

"Provide last valid value"

The last valid value (old value) from before the discrepancy occurred is immediately made available to the safety program in the fail-safe CPU as soon as a discrepancy is detected between the signals of the two input channels involved. This value remains available until the discrepancy is cleared, or until the discrepancy time has expired and a discrepancy error is detected. The sensor-actuator response time is extended by this time.

As a result, the discrepancy time for sensors connected over two channels for high-speed reactions must be tuned to short response times. Thus, it makes no sense, for example, if sensors connected via 2 channels with a discrepancy time of 500 ms trigger a time-critical shutdown. In the worst case scenario the sensor-actuator response time is extended by an amount approximately equal to the discrepancy time:

- For this reason, position the sensors in the process in such a way as to **minimize discrepancy**.
- Then select the **shortest possible** discrepancy time which is also sufficient to compensate for faulty triggering of discrepancy errors.

"Provide 0 value"

The "0" value is immediately made available to the safety program in the F-CPU as soon as discrepancy is detected between the signals of the two input channels involved.

If the "Provide 0 value" parameter is set, the sensor-actuator response time will not be influenced by the discrepancy time.

Discrepancy Time Parameter

You can define the discrepancy time for each channel pair with this parameter. The entered value is rounded to a multiple of 10 ms.

Requirements

Parameter settings:

- Type of sensor interconnection: "2-channel equivalent" or "2-channel nonequivalent"

Discrepancy Analysis and Discrepancy Time

When using a dual-channel or non-equivalent sensor which measure the same process variable, the sensors interact with a slight time delay due to the limited precision of their arrangement.

The discrepancy analysis for equality/non-equality is used at fail-safe inputs to detect errors based on the timing of two signals with the same functionality. Discrepancy analysis is initiated when different levels (when testing for nonequivalence: same levels) are detected for two associated input signals. A test is conducted to determine whether the difference in levels (when testing for nonequivalence: the consistency) disappears after a programmable period of time known as the discrepancy time. If not, this means that a discrepancy error exists.

In most cases, a discrepancy time is started, but does not fully expire since the signal differences are cleared within a short time.

Select a discrepancy time of sufficient length so that in case of no error, the difference between the two signals (when checking for nonequivalence: the consistency) has definitely disappeared before the discrepancy time expires.

Response During Discrepancy Time

While the programmed discrepancy time is running internally on the module, either the **last valid value** or "0" is returned to the safety program on the F-CPU by the input channels involved, depending on the parameter settings for the behavior of discrepancy.

Response During Discrepancy Time

If the input signals are not equivalent following expiration of the specified discrepancy time (when checking for nonequivalence: no inequality), for example due to wire break at a sensor line, the system detects a discrepancy error and generates a "discrepancy" diagnostic message in the diagnostic buffer of the F-I/O module to identify the faulty channels.

Reintegration After Discrepancy Error Parameter

With this parameter you can define the criteria for clearing discrepancy errors which, when fulfilled, facilitate reintegration of the relevant input channels. Programming options:

- "Zero signal test required" or
- "Zero signal test not required"

"Zero signal test required"

When "Zero signal test required" is set, a discrepancy error is not considered cleared until a zero signal is set at both input channels.

When using nonequivalent sensors, that is, "2-channel nonequivalent" is set at the "Type of sensor interconnection" parameter, the zero signal must again be set at the channel which provides the wanted signal.

"Zero signal test not required"

When "Zero signal test not required" is set, a discrepancy error is considered cleared when a discrepancy no longer exists between the two input channels.

SIMATIC S7 F-modules, for which you cannot program the "Reintegration after discrepancy error" parameter, also behave in this way.

Readback Time Parameter

Each output channel has its own selectable readback time. This time specifies the maximum duration of the turn off test for the corresponding channel and therefore also the readback time for turning off the channel.

The following readback times can be set: 1 ms, 5 ms, 10 ms, 50 ms, 100 ms, 200 ms and 400 ms.

You should set an adequately high readback time if the channel involved switches high capacitive loads. If the readback time for a controlled capacitive load is set too low, the output channel is passivated because the discharge of the capacitance does not take place within the turn off test.

If the readback signals are incorrect, the "short circuit" fault only causes passivation of the output channel after the readback time elapses.

 **WARNING**

With a configured readback time of ≥ 50 ms, short-circuits (cross-circuits) can be suppressed with an interference signal with a frequency > 10 Hz (50:50 duty cycle).

Short-circuits (cross-circuits) on an output of the same module will be detected.

7.6.5 Input applications of EM 4 F-DI/3 F-DO DC24V PROFIsafe

Conditions for achieving SIL/Category/PL

The table below lists the conditions which have to be met for achieving the various safety categories.

Table 7- 28 EM 4 F-DI/3 F-DO DC24V PROFIsafe: Conditions for achieving SIL/Category/PL

| Application | Sensors | Sensor evaluation | Sensor supply | achievable SIL/Category/PL |
|-------------|--------------------------|-------------------|---|----------------------------|
| 1.1 | 1-channel | 1oo2 | Internal, with/without short-circuit test | 2 / 3 / d |
| | | | external | |
| 1.2 | 2-channel equivalent | 1oo2 | Internal, with/without short-circuit test | |
| | | | external | |
| 1.3 | 2-channel, nonequivalent | 1oo2 | Internal, with/without short-circuit test | |
| | | | external | |

Sensor Requirements

Please note the information in section *"Requirements for Sensors and Actuators"* when using sensors for safety-related applications.

Assigning Inputs to Each Other

The EM 4 F-DI/3 F-DO DC24V PROFIsafe has 8 fail-safe inputs, DI 0 through DI 7 (SIL2). Each pair of these inputs can be operated as one input (SIL2). The following assignment applies:

- DI0 with DI4
- DI1 with DI5
- DI2 with DI6
- DI3 with DI7

Sensor Supply

The 4 F-DI/3 F-DO DC24V PROFIsafe EM makes available the VS sensor supply for the Inputs 0 to 7.

The sensors can be powered internally or externally.

Application 1.1: Wiring diagram for connecting single-channel sensor to two inputs

Single-channel connection of a sensor to two inputs of the F-module for each process signal (1oo2 evaluation).

The wiring is carried out on the appropriate terminal module.

PM-E

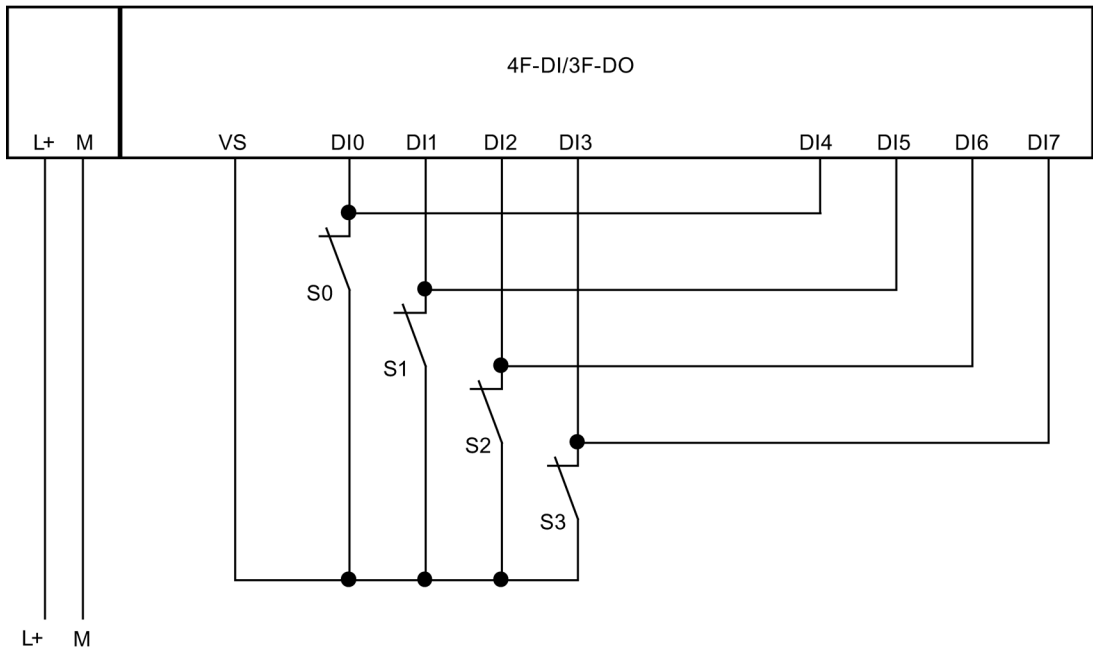

Figure 7-37 Wiring diagram EM 4 F-DI/3 F-DO DC24V - one sensor connected via one channel to two inputs, internal sensor supply

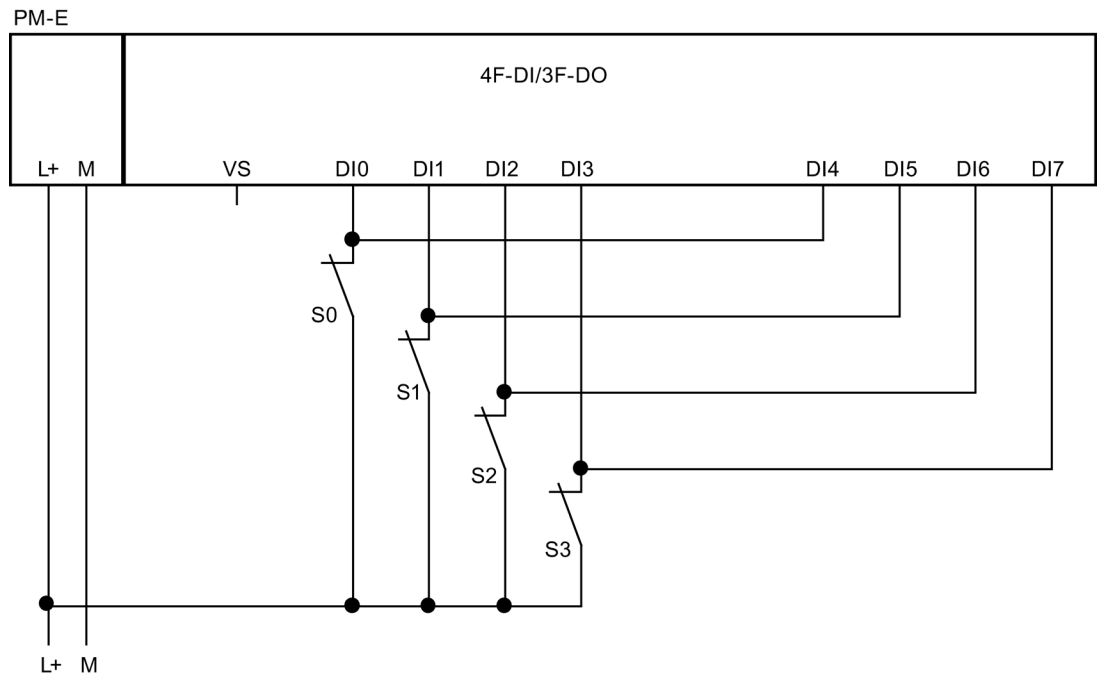

Figure 7-38 Wiring diagram EM 4 F-DI/3 F-DO DC24V - one sensor connected via one channel to two inputs, external sensor supply

⚠ WARNING

To achieve SIL2/Category 3/PLd using this wiring, you must use a suitably qualified sensor.

Assignable Parameters for Application 1.1

You can activate or deactivate the "short-circuit test" parameter. For digital inputs connected to an external supply, set the "Sensor supply" parameter for the corresponding digital input to "external". The program will otherwise report a "short circuit" diagnostics event if the "short-circuit test" is activated.

Special Features of Fault Detection in Application 1.1

The following table presents fault detection according to the sensor supply and the parameter assignment for the short-circuit test:

Table 7- 29 EM 4 F-DI/3 F-DO DC24V PROFIsafe: Fault detection

| Example of fault | Fault detection if ... | | |
|---|---|---|------------------------|
| | internal sensor supply and short-circuit test activated | internal sensor power supply and short-circuit test are deactivated | external sensor supply |
| Short-circuit DI0 with DI1 | No | No | No |
| Short-circuit DI0 with DI5 | No | No | No |
| P short-circuit DI0 | Yes | No | No |
| M short-circuit DI0 | Yes* | Yes* | No |
| Discrepancy error | Yes | Yes | Yes |
| P-short circuit in sensor supply | Yes | No | No |
| M-short-circuit in sensor supply or defective | Yes | Yes | Yes |
| Short-circuit SS with DI0 | No | No | No |
| Supply voltage fault | Yes | Yes | Yes |

*: Fault is detected only in case of signal corruption. In other words, the signal read differs from the sensor signal (discrepancy error). If there is no signal corruption with respect to the sensor signal, fault detection is not possible and is not required from a safety standpoint.

| |
|--|
|  WARNING |
| If the short-circuit test is disabled or cannot be enabled, the wiring between the sensor and input channel must be short circuit-proof. |

Application 1.2: Wiring diagram for connecting a 2-channel sensor to two channels

A 2-channel sensor is connected to two inputs of the F-module for each process signal (1oo2 evaluation).

The wiring is carried out on the appropriate terminal module.

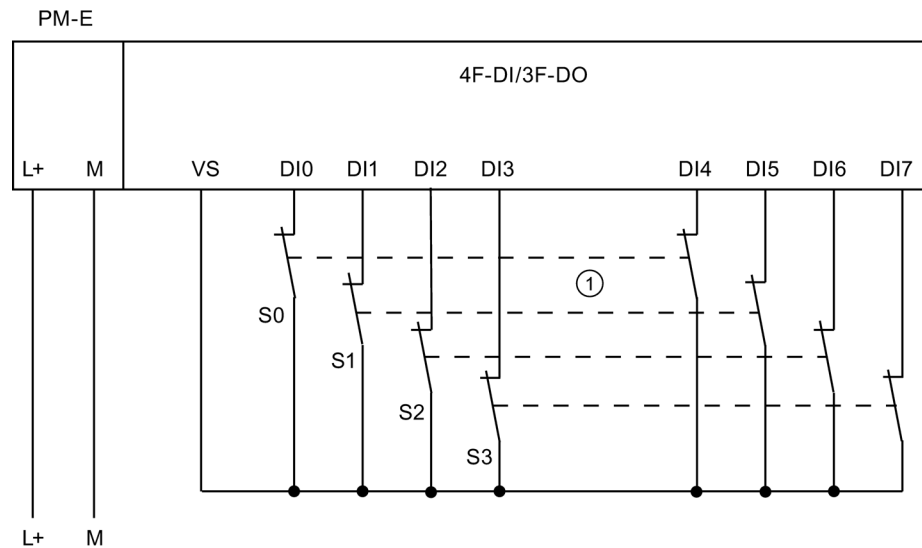

Figure 7-39 Wiring diagram EM 4 F-DI/3 F-DO DC24V - a 2-channel sensor connected via two channels, internal sensor supply

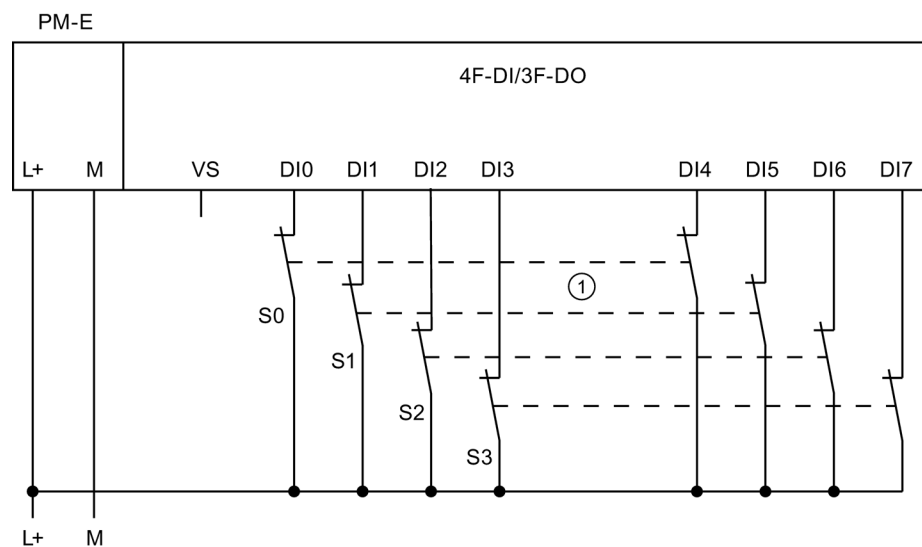

Figure 7-40 Wiring diagram EM 4 F-DI/3 F-DO DC24V - a 2-channel sensor connected via two channels, external sensor supply

Wiring diagram of the connection of two single-channel sensors to two channels

Two single-channel sensors are connected via two channels to two inputs of the F-module for each process signal (1oo2 evaluation). The sensors can also be connected to an external sensor supply.

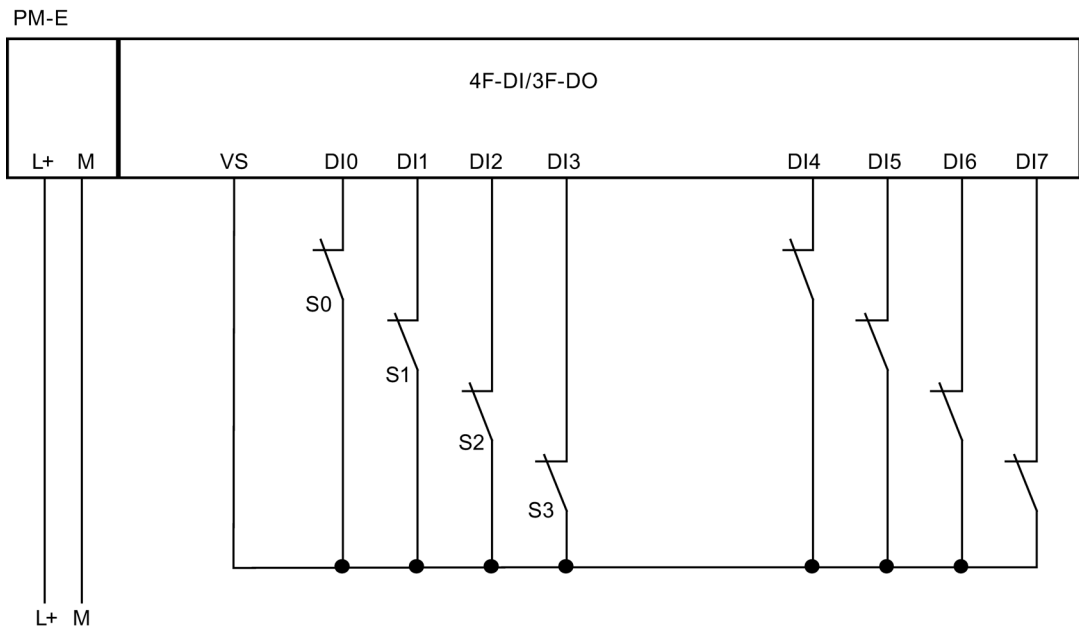



Figure 7-41 Wiring diagram EM 4 F-DI/3 F-DO DC24V - two 1-channel sensors connected via two channels, internal sensor supply

| |
|--|
|  WARNING |
| To achieve SIL3/Category 3/PLd using this wiring, you must use a suitably qualified sensor. |

Assignable Parameters for Application 1.2

Set the "Type of sensor interconnection" parameter to "2-channel equivalent" for the corresponding input.

You can activate or deactivate the "short-circuit test" parameter. For digital inputs connected to an external supply, set the "Sensor supply" parameter for the corresponding digital input to "external". The program will otherwise report a "short circuit" diagnostics event if the "short-circuit test" is activated.

Special Features of Fault Detection in Application 1.2

The following table presents fault detection according to the sensor supply and the parameter assignment for the short-circuit test:

Table 7- 30 EM 4 F-DI/3 F-DO DC24V PROFIsafe: Fault detection

| Example of fault | Error detection condition ... | | |
|---|---|---|------------------------|
| | Internal sensor supply and short-circuit test are activated | Internal sensor supply and short-circuit test are deactivated | external sensor supply |
| Short-circuit DI0 with DI1 | Yes* | Yes* | Yes* |
| Short-circuit DI0 with DI4 | No | No | No |
| Short-circuit DI0 with DI5 | Yes* | Yes* | Yes* |
| P short-circuit DI0 | Yes* | Yes* | Yes* |
| M short-circuit DI0 | Yes* | Yes* | Yes* |
| Discrepancy error | Yes | Yes | Yes |
| P-short circuit in sensor supply | Yes | No | No |
| M-short circuit in sensor supply or defective | Yes | Yes | Yes |
| Short-circuit SS with DI0 | Yes* | Yes* | Yes* |
| Supply voltage fault | Yes | Yes | Yes |

*: Fault is detected only in case of signal corruption. In other words, the signal read differs from the sensor signal (discrepancy error). If there is no signal corruption with respect to the sensor signal, fault detection is not possible and is not required from a safety standpoint.

WARNING

If the short-circuit test is not activated or the sensor supply to digital inputs is set to "external", the wiring between the sensor and the input channel must be short circuit-proof.

Application 1.3: Wiring diagram of the nonequivalent connection of a nonequivalent sensor to two channels

A nonequivalent connection of a 2-channel sensor is connected nonequivalently to two inputs of the F-I/O module for each process signal (1oo2 evaluation).

The left-hand channels on the F-module (DI0 through DI3) supply the wanted signals. If no faults are detected, these signals will be available in the I/O area for inputs on the F-CPU.

The wiring is carried out on the appropriate terminal module.

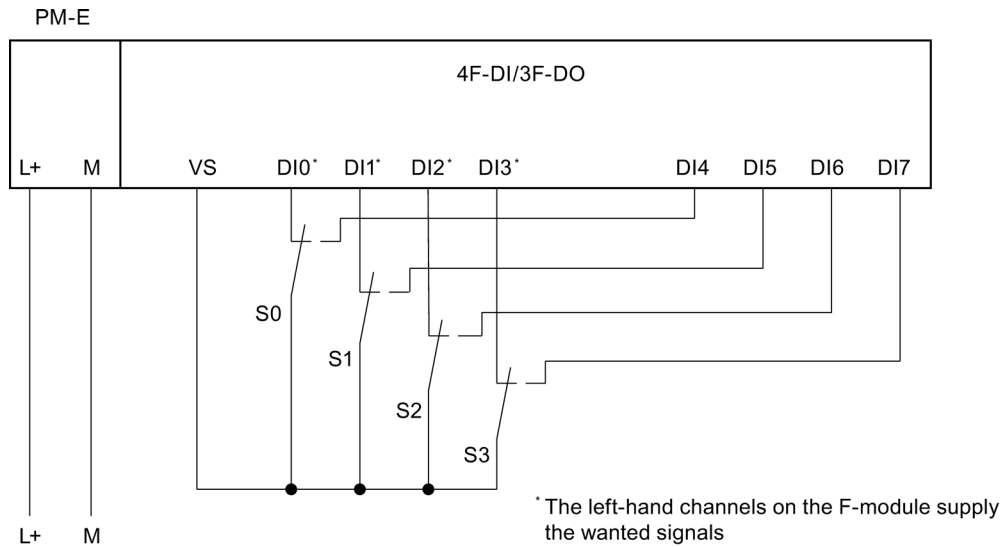

Figure 7-42 Wiring diagram EM 4 F-DI/3 F-DO DC24V - a nonequivalent 2-channel sensor connected via two channels non-equivalently, internal sensor supply

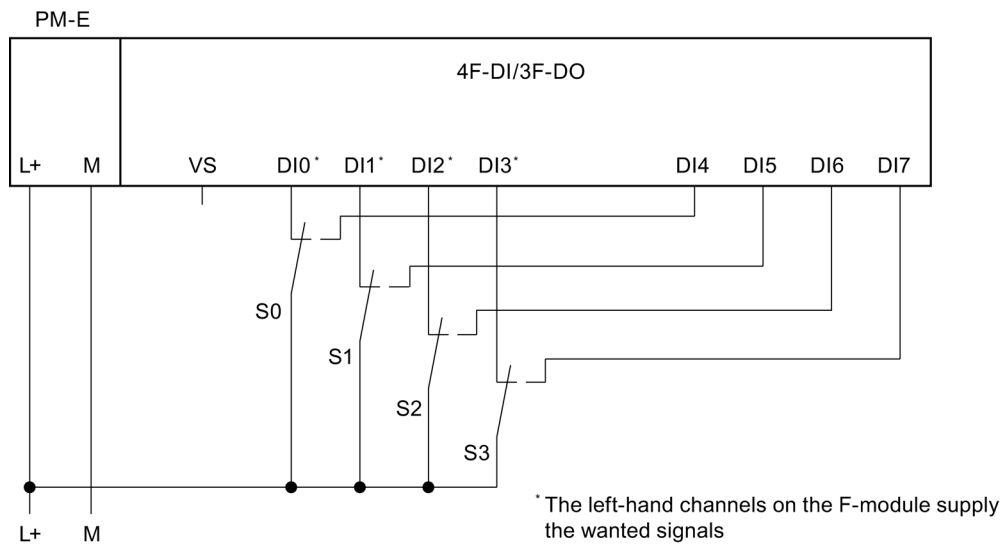

Figure 7-43 Wiring diagram EM 4 F-DI/3 F-DO DC24V - a non-equivalent sensor connected via two channels non-equivalently, external sensor supply

Wiring Diagram for Nonequivalent Connection of Two Single-Channel Sensors to Two Channels

Two single-channel sensors are connected via two channels to two inputs of the F-module for each process signal (1oo2 evaluation).

The left-hand channels on the F-module (DI0 through DI3) supply the wanted signals. If no faults are detected, these signals will be available in the I/O area for inputs on the F-CPU.

The sensors can also be connected to an external sensor supply.

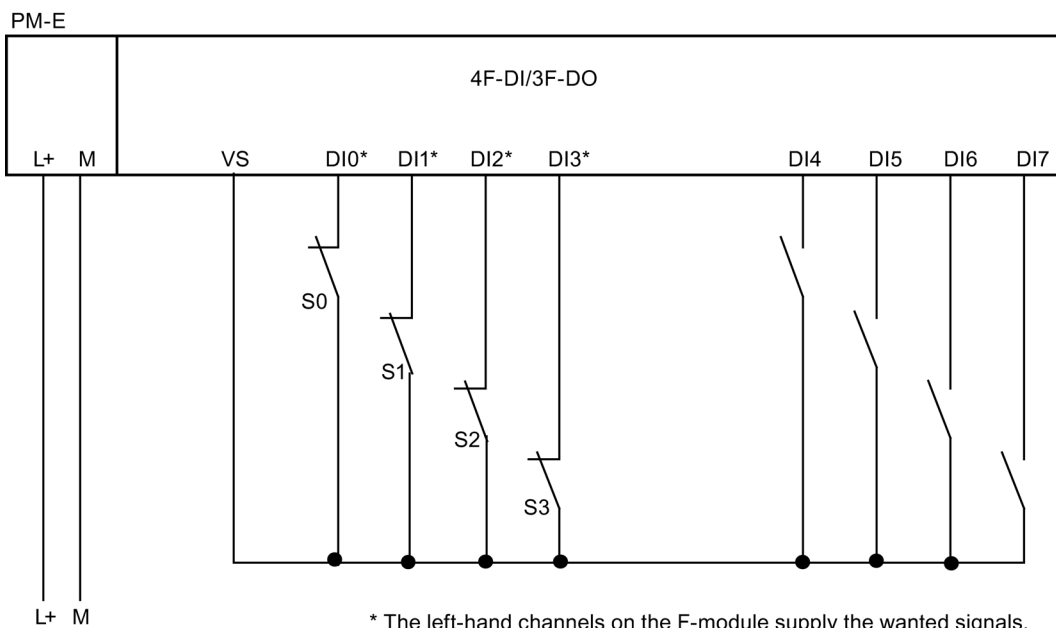

Figure 7-44 Wiring diagram EM 4 F-DI/3 F-DO DC24V - two 1-channel sensors connected via two channels, internal sensor supply

WARNING

To achieve SIL3/Category 3/PLd using this wiring, you must use a suitably qualified sensor.

Assignable Parameters for Application 1.3

You can activate or deactivate the "short-circuit test" parameter. For digital inputs connected to an external supply, set the "Sensor supply" parameter for the corresponding digital input to "external". The program will otherwise report a "short circuit" diagnostics event if the "short-circuit test" is activated.

Special Features of Fault Detection in Application 1.3

The following table presents fault detection according to the sensor supply and the parameter assignment for the short-circuit test:

Table 7- 31 EM 4 F-DI/3 F-DO DC24V PROFIsafe: Fault Detection (Application 1.3)

| Example of fault | Fault detection if ... | | |
|---|---|---|------------------------|
| | Internal sensor supply and short-circuit test are activated | Internal sensor supply and short-circuit test are deactivated | external sensor supply |
| Short-circuit DI0 with DI1 | Yes* | Yes* | Yes* |
| Short-circuit DI0 with DI4 | Yes | Yes | Yes |
| Short-circuit DI0 with DI5 | Yes* | Yes* | Yes* |
| P short-circuit DI0 | Yes* | Yes* | Yes* |
| M short-circuit DI0 | Yes* | Yes* | Yes* |
| Discrepancy error | Yes | Yes | Yes |
| P-short circuit in sensor supply | Yes | No | No |
| M-short circuit in sensor supply or sensor supply defective | Yes | Yes | Yes |
| Short-circuit SS with DI0 | Yes* | Yes* | Yes* |
| Supply voltage fault | Yes | Yes | Yes |

*: Fault is detected only in case of signal corruption. In other words, the signal read differs from the sensor signal (discrepancy error). If there is no signal corruption with respect to the sensor signal, fault detection is not possible and is not required from a safety standpoint.

See also

Requirements for Sensors and Actuators (Page 50)

Using fail-safe ET 200S modules (Page 16)

7.6.6 Output applications of EM 4 F-DI/3 F-DO DC24V PROFIsafe

Application 1: Wiring a load to each digital output

Each of the three fail-safe digital outputs consists of one DOx P P-switch and one DOx M M-switch. You connect the load between P and M-switches. The two switches are always activated so that voltage is applied to the load.

The wiring is carried out on an appropriate terminal module.

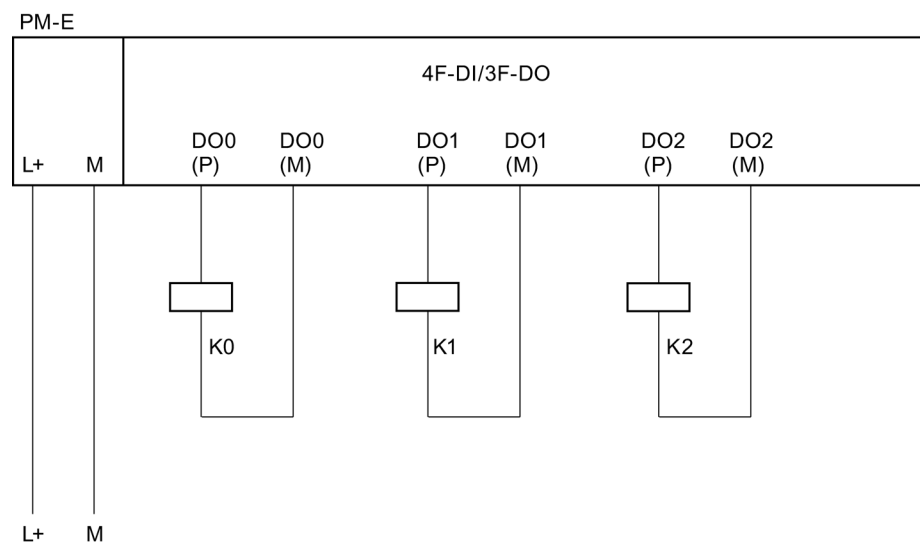

Figure 7-45 Wiring Diagram EM 4 F-DI/3 F-DO DC24V - Output Circuit

Note

In order to achieve SIL2/Category 3/PLd with this wiring, you must install a suitably-qualified actuator, for example in accordance with IEC 60947.

Application 2: Wiring loads to L+ and M at each digital output

Not allowed.

Application 3: Wiring Two Loads in Parallel to each Digital Output

Avoiding/Managing Cross-Circuits:

To protect against cross circuits between P and M-switches in fail-safe digital outputs, we recommend the following wiring scheme:

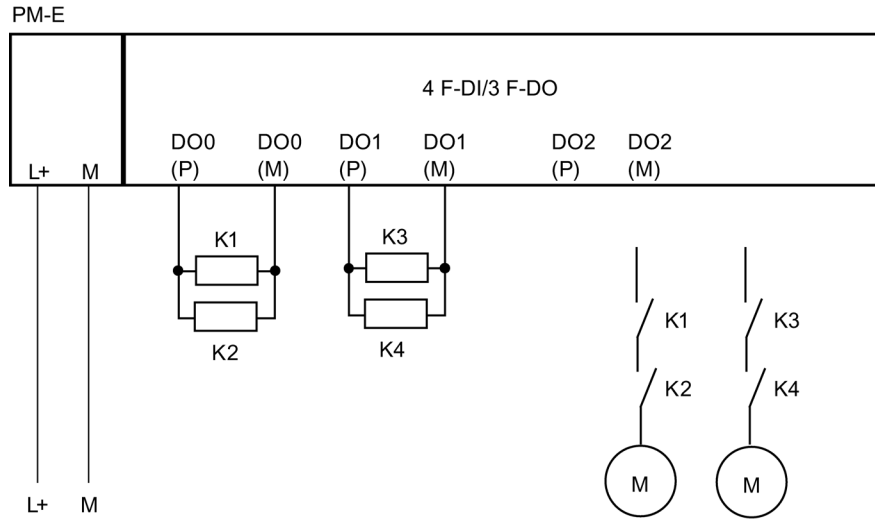

Figure 7-46 Diagram of Two Relays Wired in Parallel to 1 F-DO of EM 4 F-DI/3 F-DO DC24V

7.6.7 Diagnostic functions of EM 4 F-DI/3 F-DO DC24V PROFIsafe

Behavior in Case of Supply Voltage Failure

Failure of the Vs sensor power supply of the EM 4 F-DI/3 F-DO DC24V PROFIsafe is indicated by the VsF LED on the F-module. This information is also provided in the module (diagnostic entry). Either all channels of the module are passivated or, in the case of channel-specific passivation, the relevant channels are passivated.

In the case of a voltage dip in the external auxiliary voltage, the SF LED lights up, the module is passivated.

With the subsequent supply recovery (level must remain above the specified value for at least 1 minute (refer to the technical specifications: voltages, currents, electrical potentials)) the SF LED goes out again, the module remains passivated. The SF LED flashes if there are no other errors, until the error is acknowledged.

Behavior in Case of Cross-Circuit/Short-Circuit at the Sensor Supply

When operating with programmed external sensor supply and blocked short-circuit test, you enable the detection of M-short-circuits to M at the sensor supply and signaling at the corresponding VsF LED. No entries are made in the diagnostics data of the module.

When operating with external sensor supply and cyclic short-circuit test, you enable the detection of M and P-short-circuits at the sensor supply and signaling at the corresponding VsF LED. No entries are made in the diagnostics data of the module.

Diagnostic functions

The table below provides an overview of the diagnostic functions of the EM 4 F-DI/3 F-DO DC24V PROFIsafe. The diagnostic functions are assigned either to one channel or to the entire module.

Table 7- 32 Diagnostic functions of the EM 4 F-DI/3 F-DO DC24V PROFIsafe

| Diagnostic Function* | Fault Number | LED | is signaled in application | Effective range of diagnostics | Can be Assigned Parameters |
|--|-----------------|-----------|----------------------------|--------------------------------|----------------------------|
| Short-circuit | 1 _H | SF | 1.1 - 1.3 | Channel | No |
| Short-circuit (on the sensor supply) | 1 _H | VsF SF | 1.1 - 1.3 | Channel | Yes |
| Internal error | 9 _H | SF | 1.1 - 1.3 | Module | No |
| Parameter assignment error | 10 _H | SF | 1.1 - 1.3 | Module | No |
| Sensor voltage or load voltage missing | 11 _H | SF | 1.1 - 1.3 | Module | No |
| Communication error | 13 _H | SF | 1.1 - 1.3 | Module | No |
| Safety-related shutdown | 19 _H | SF | 1.1 - 1.3 | Channel | No |

| Diagnostic Function* | Fault Number | LED | is signaled in application | Effective range of diagnostics | Can be Assigned Parameters |
|---|--------------|-----|----------------------------|--------------------------------|----------------------------|
| Discrepancy error | 19H | SF | 1.1 - 1.3 | Channel | No |
| *: Specially for F-modules; display in <i>STEP 7</i> , see "Channel-Specific Diagnostics, Fault Types of Fail-Safe Modules" table | | | | | |

| |
|---|
|  WARNING |
| Before acknowledging the short-circuit diagnosis, remedy the respective error and validate your safety function. In this case, follow the steps described in section "Reactions to Faults (Page 53)". |

Special Features for Fault Detection

The detection of certain faults (short-circuits or discrepancy errors, for example) depends on the application, the wiring, and the parameter assignment of the short-circuit test and the sensor power supply. For this reason, tables on fault detection for the applications are presented in "*Application 1.1*" to "*Application 1.3*".

Causes of Faults and Corrective Measures

The following table contains the possible causes of the faults described for the individual diagnostic messages of the EM 4 F-DI/3 F-DO DC24V PROFIsafe and remedies.

Table 7- 33 Diagnostic messages of the EM 4 F-DI/3 F-DO DC24V PROFIsafe, causes of errors and remedies

| Diagnostic Message | Fault detection | Possible Causes | Corrective Measures |
|----------------------------|-------------------------------|---|---|
| Short-circuit | Depends on parameter settings | Short-circuit in the sensor/actuator | Eliminate the short-circuit |
| | | Cross-circuit at the sensor/actuator | Eliminate the cross-circuit within 100 hours after the error has occurred. |
| | | Sensor supply short-circuit | Eliminate the short-circuit |
| | | Internal error | Replace module |
| Internal error | Always | Internal module fault has occurred | Replace module |
| Parameter assignment error | Always | Inserted module does not match configuration Faulty parameter assignment | Correct configuration (compare actual and preset configuration) Check communication paths Correct configuration |
| | | PROFIsafe address set incorrectly in the F-module | Check whether the PROFIsafe address on the module matches the configuration in <i>HW Config</i> |

| Diagnostic Message | Fault detection | Possible Causes | Corrective Measures |
|--|-----------------|--|--|
| Sensor voltage or load voltage missing | Always | No supply voltage or supply voltage is too low | Check the supply voltage on the interconnected PM, Check module for correct contact |
| Communication error | Always | Error in communication between F-CPU and module due to defective PROFIBUS connection or higher than permissible EMI, for example | Check the PROFIBUS/PROFINET connection Eliminate the interference |
| | | PROFIsafe monitoring time set too low | Set a greater value for the "F monitoring time" parameter for the module in <i>HW Config</i> |
| | | Configuration of the F-module does not match safety program | Generate safety program again; then load configuration and safety program into F-CPU again |
| Safety-related shutdown | Always | Faulty process signal Defective sensor | Check process signal, replace sensor if necessary |
| | | Short-circuit between unconnected sensor cable and the sensor supply cable | Eliminate the short-circuit |
| | | Wire break in connected sensor cable or the sensor supply cable | Eliminate broken wire |
| | | Assigned discrepancy time too short | Check the configured discrepancy time |
| | | Switching frequency exceeded | Reduce the switching frequency |
| | | | Once the fault is eliminated, the F-module must be reintegrated in the safety program |

You can find detailed information on F I/O passivation and reintegration under "*Diagnostics*" in the *S7 Distributed Safety, Configuring and Programming* manual or the *S7 F/FH Systems, Configuring and Programming* manual.

Generally applicable information on diagnostics

For information on diagnostics that affects all fail-safe modules (such as readout of diagnostic functions; passivation of channels) see this manual in "*Diagnostics*" and the *S7 Distributed Safety, Configuration and Programming* manual or *S7 F/FH Systems, Configuring and Programming*.

See also

Fault Diagnostics (Page 55)

7.6.8 Technical specifications of the EM 4 F-DI/3 F-DO DC24V PROFIsafe

Overview

| Technical specifications | |
|---|-----------------------------|
| Dimensions and weight | |
| Dimensions W x H x D (mm) | 30 x 81 x 52 |
| Weight | Approx. 73 g |
| Data for Specific Module | |
| Number of inputs | |
| • 2-channel | 4, maximum |
| Number of outputs (P/M switching) | 3, maximum |
| Assigned address area | |
| • I/O area for inputs | 7 bytes |
| • I/O area for outputs | 5 bytes |
| Length of cable | |
| • Unshielded * | 30 m, maximum |
| • Shielded * | 30 m, maximum |
| Maximum achievable safety class | |
| • in accordance with IEC 61508:2000 | SIL2 |
| • in accordance with ISO 13849-1:2006 or EN ISO 13849-1:2008 | Cat.3/PLd |
| Safety characteristics | SIL2 |
| • Low demand mode (average probability of failure on demand) | < 1.00E-04 |
| • High demand/continuous mode (probability of a dangerous failure per hour) | < 1.00E-08 |
| • Acceptance ID | cULus, FM, ATEX, CE, C-Tick |
| Voltages, Currents, Potentials | |
| Rated supply voltage L+ | 24 VDC |
| • permissible range ** | 20.4 V to 28.8 V |
| • Power loss ride-through of L+ | None |
| • Power loss ride-through of internal P5 | 5 ms |
| • Reverse polarity protection | No |

| Technical specifications | |
|---|--|
| Number of simultaneously controllable inputs | |
| <ul style="list-style-type: none"> • Horizontal installation <ul style="list-style-type: none"> – Up to 60 °C | 8 (with 28.8 V) |
| <ul style="list-style-type: none"> • Vertical installation <ul style="list-style-type: none"> – Up to 40 °C | 8 |
| Total current of outputs | |
| <ul style="list-style-type: none"> • Horizontal installation <ul style="list-style-type: none"> – Up to 40 °C – Up to 60 °C | 6 A 4 A |
| <ul style="list-style-type: none"> • Vertical installation <ul style="list-style-type: none"> – Up to 40 °C | 4 A |
| Electrical isolation | |
| <ul style="list-style-type: none"> • Between channels and backplane bus | Yes |
| <ul style="list-style-type: none"> • Between channels and power supply | No |
| <ul style="list-style-type: none"> • Between channels | No |
| <ul style="list-style-type: none"> • Between channels/power supply and shield | Yes |
| Permissible potential difference between | |
| <ul style="list-style-type: none"> • Shield against ET 200S bus connection | 75 V DC/60 V AC |
| <ul style="list-style-type: none"> • Shield against I/O (DIs, DOs, P1/P2 buses) | 75 V DC/60 V AC |
| <ul style="list-style-type: none"> • ET 200S bus connection against I/O (DIs, DOs, P1/P2 buses) | 250 V AC |
| Isolation in the series tested with | |
| <ul style="list-style-type: none"> • ET 200S bus connection against I/O (DIs, DOs, P1/P2 buses) | 2545 V DC/2 s |
| Isolation in the type test tested with | |
| <ul style="list-style-type: none"> • Shield against ET 200S bus connection | 370 VAC/1 min |
| <ul style="list-style-type: none"> • Shield against I/O (DIs, DOs, P1/P2 buses) | 370 VAC/1 min |
| <ul style="list-style-type: none"> • ET 200S bus connection against I/O (DIs, DOs, P1/P2 buses) | 2830 V AC/1 min |
| Current consumption | |
| <ul style="list-style-type: none"> • From backplane bus | < 20 mA |
| <ul style="list-style-type: none"> • From load voltage L+ (without load) | 70 mA, typical |
| Power loss of the module | 3.5 W, typical |
| Status, interrupts, diagnostics | |
| Status display | |
| Inputs | Red/green LED per channel |
| Outputs | Red/green LED per channel |
| Sensor supply | Red VsF LED and display at channel LED |

| Technical specifications | | |
|---|--|--------------------|
| Diagnostic functions | | |
| <ul style="list-style-type: none"> Group fault display | Red LED (SF) | |
| <ul style="list-style-type: none"> Diagnostic information can be displayed | Possible | |
| Sensor Supply Outputs | | |
| Number of outputs | 1 | |
| Output voltage | | |
| <ul style="list-style-type: none"> Loaded | Minimum L+ (-1.5 V) | |
| Output current | | |
| <ul style="list-style-type: none"> Rated value | 400 mA | |
| <ul style="list-style-type: none"> Permissible range | 0 mA to 400 mA | |
| Short-circuit protection | Yes, electronic | |
| <ul style="list-style-type: none"> Operating value | 4 A to 9 A | |
| Specifications for sensor selection * | | |
| Input voltage | | |
| <ul style="list-style-type: none"> Rated value | 24 VDC | |
| <ul style="list-style-type: none"> For "1" signal | 15 V to 30 V | |
| <ul style="list-style-type: none"> For "0" signal | -30 V to 5 V | |
| Input current | | |
| <ul style="list-style-type: none"> For "1" signal | 3.5 mA, typical | |
| Input delay * | | |
| <ul style="list-style-type: none"> For "0" after "1" | Typically 3 ms | (2.6 ms to 3.4 ms) |
| <ul style="list-style-type: none"> For "1" after "0" | Typically 3 ms | (2.6 ms to 3.4 ms) |
| Input characteristic | In accordance with IEC 61131-2 Type 1 | |
| Connection of 2-wire proximity switch | Not possible | |
| Data for Selecting an Actuator* | | |
| Output voltage | | |
| <ul style="list-style-type: none"> For "1" signal | <ul style="list-style-type: none"> Minimum L+ (-2 V) P-switch: Minimum L+ (-1.5 V); voltage drop in M-switch: 0.5 V, maximum | |
| Output current for "1" signal | | |
| <ul style="list-style-type: none"> Rated value | 2 A | |
| <ul style="list-style-type: none"> Permissible range | 20 mA to 2.4 A | |
| For "0" signal (residual current) | 0.5 mA, maximum | |
| Indirect control of load by means of interface relay: | | |
| For "0" signal (residual current) | 0.5 mA, maximum | |
| Load resistance range | 12 Ω to 1 kΩ | |
| Lamp load | 10 W, maximum | |

| Technical specifications | |
|--|--|
| Parallel connection of 2 outputs | Not possible |
| Control of a digital input | Not possible |
| Switching frequency | |
| • With resistive load | 30 Hz, maximum |
| • With inductive load in accordance with IEC 60947-5-1, DC13 | 0.1 Hz, maximum |
| • With lamp load | 10 Hz, maximum |
| Voltage induced on current interruption limited to | L+ (-2×47 V), typical |
| Short-circuit protection of output | Yes, electronic |
| • Response threshold (short-circuit) | 5 A to 12 A |
| • Response threshold (external M-short-circuit) | 5 A to 12 A |
| • Response threshold (external P-short-circuit) | 4 A to 12 A |
| Time, Frequency | |
| Internal processing times | See "Response times" |
| Acknowledgment time in safety mode | Max. 9 ms |
| Minimum sensor signal duration | See "Minimum Duration of Sensor Signals to Allow Correct Detection by the F-DI Module" table in "Wiring and Fitting Modules" |
| Protection against overvoltage | |
| Protection of power supply L+ from surge in accordance with IEC 61000-4-5 with external protection elements only | |
| • Symmetrical (L+ to M) | + 1 kV; 1.2/50 µs |
| • Asymmetrical (L+ to PE, M to PE) | + 2 kV; 1.2/50 µs |
| <p>*: For more information on the requirements for encoders and actuators, refer to the section "Wiring and Fitting Modules (Page 45)".</p> <p>**: Operating below the permissible supply voltage is only permissible for the repair time. See section "Introduction (Page 75)".</p> <p>Operating above the permissible supply voltage can damage the fail-safe module because of the increased power loss (reduced service life). If an input becomes defective because of this, the fail-safe module reports the safe state of the input (passivation). At a supply voltage > 35.5 V, the fuse blows and the output drivers are disabled.</p> | |

7.7 4 F-DO DC24V/2A PROFIsafe digital electronic module

7.7.1 Properties of the 4 F-DO DC24V/2A PROFIsafe Digital Electronic Module

Order Number

6ES7138-4FB04-0AB0

Properties

The 4 F-DO DC24V/2A PROFIsafe digital electronic module possesses the following properties:

- Four outputs, P/M switching
- 2 A output current
- Rated load voltage 24 VDC
- Suitable for solenoid valves, DC contactors and indicator lights
- Group fault display (SF; red LED)
- Status display for each output (green LED)
- Assignable diagnostics
- Safety class SIL3 attainable
- Module-internal diagnostic buffer available
- Firmware update
- Identification data I&M

Power Modules Suitable for SIL2 or SIL3

Table 7- 34 EM 4 F-DO DC24V/2A PROFIsafe: Power module for SIL/Category/PL

| Power Module | achievable SIL/Category/PL |
|--|----------------------------|
| Supply through PM-E DC24V, PM-E DC24V/AC120/230V or PM-E DC24..48V | SIL3/Category 4/PLe |

Safety-Related Shutdown of Standard Load Groups

If no more than 2 A current are required, the safety-related shutdown of standard load groups (consisting of standard power module and standard output modules) is made directly with the P/M-switching EM 4 F-DO DC24V/2A PROFIsafe. If 2 A or more of current are required, the EM 4 F-DO DC24V/2A PROFIsafe must be used in combination with the electronic module 1 F-RO DC24V/AC24..230V/5A (control of F-RO module performed via fail-safe output).

Refer to the Internet (<http://support.automation.siemens.com/WW/view/en/39198632>) for a list of released standard ET 200S output modules.

WARNING

Safety-related activation of standard DO module outputs is not possible. Only safety-related **shutdown** is possible. The following issues must therefore be taken into consideration:

In the worst case, you must consider all possible faults of the standard DO modules and the programs controlling them for which the faults cannot be found directly. For example, the EM 4 F-DO DC24V/2A PROFIsafe does not detect external short-circuits to L+ at the standard DO module outputs. All faults developing at the standard DO modules influence the process via final controlling elements. The process status must be made known to the F-CPU by way of sensors and a suitable safety program.

Diagnostic functions must be handled indirectly in the controlled process since the self-test function of standard DO modules cannot be used to detect safety-critical faults: The safety control function does not intervene in the faulty process as long as hazards can be excluded. However, it shuts down the system if the process develops unwanted or potentially dangerous activities.

Consequently, instead of the short fault reaction times defined in S7, the reaction time to internal faults in standard DO modules is determined by the controlled process and its corresponding feedback signals.

Safety-related process values must be

- safely
- read in by way of fail-safe input modules (e.g. F-DI),
- prepared by the F-CPU for output commands and
- output at the fail-safe output module for shutdown of the corresponding safety relay or
- output at the fail-safe power module PM-E F.

If the process does not respond as expected due to malfunctions within a process or faulty standard DO modules, these standard DO modules must be set to safe state by way of the higher-level safety circuit.

The process safety time is of particular importance here. Risks due to any malfunctions within the process control system can be ruled out within this process safety time.

The safety program must react in a safety-related and logically suitable fashion to unwanted or potentially dangerous states in the process via the EM 4 F-DO DC24V/2A PROFIsafe and fail-safe output modules.

If you want to completely avoid the problems described above, we recommend you use P/M-switching fail-safe electronic module 4 F-DO DC24V/2A PROFIsafe with standard ET 200S power modules (see table "Assigning power modules to electronic modules / motor starters and safety class").

Property of safety-related shutdown of standard DO modules with the EM4 F-DO DC24V/2A PROFIsafe:

This cost-effective solution allows the full and simultaneous shutdown of all outputs involved when a fault is detected in the process or on the EM 4 F-DO DC24V/2A PROFIsafe.

Property of the individual shutdown of F-modules with fail-safe outputs:

The scope of shutdown is kept to a minimum when a fault is detected. It is also possible to react to critical process states staggered over time, or to perform safety-related shutdown of individual outputs.

Switching Grounded Loads

If the EM 4 F-DO DC24V/2A PROFIsafe switches loads that have a chassis-ground connection (for example to improve EMC characteristics) **and** if chassis and ground are connected at the power supply being used, a "short-circuit" is detected.

From the perspective of the F-module, the M-switch is bridged by the chassis-ground connection (refer to the diagram below as an example of an EM 4 F-DO DC24V/2A PROFIsafe).

Remedy:

- Using the PM-E F pp DC24V PROFIsafe
- The value of the resistance between chassis and ground at the load end must be greater than 100 kΩ

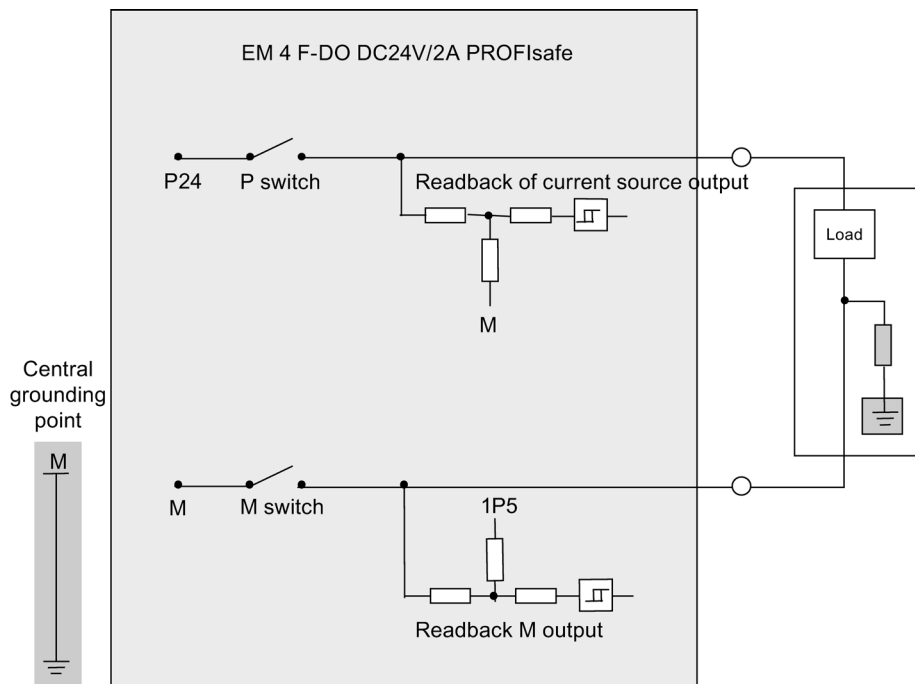

Figure 7-47 Switching Grounded Loads (resistance between chassis and ground)

Capacitive Crosstalk of Digital Input/Output Signals

Refer to *"Properties of the power module PM-E F pm DC24V PROFIsafe"*.

Magnetic crosstalk with inductive loads

Note

Note that an inductive load connected to the DO channels can induce voltages in the case of electromagnetic interference of a strong magnetic field. This can cause a short-circuit error message.

Remedy:

- Spatially disconnect the inductive loads or shield against the magnetic field.
- Set the parameters for the readback time to 50 ms or higher.

7.7.2 Terminal assignment of the EM 4 F-DO DC24V/2A PROFIsafe

Front View

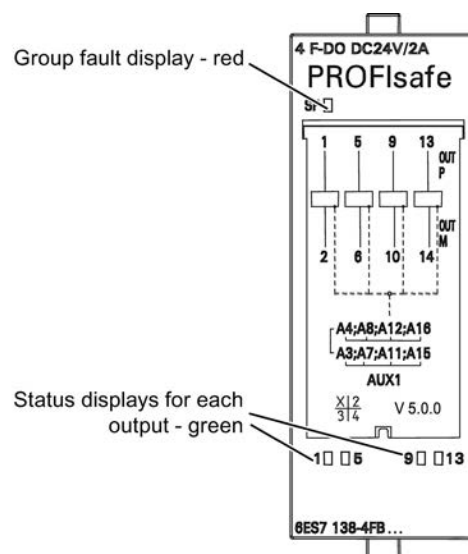

Figure 7-48 Front view EM 4 F-DO DC24V/2A PROFIsafe

WARNING

The SF LED and the status displays of the inputs/outputs are not designed for safety-related functions and may therefore not be evaluated for safety-related activities.

Terminal Assignment

The diagram below shows the terminal assignment of the EM 4 F-DO DC24V/2A PROFIsafe for the supported terminal modules TM-E30S44-01, TM-E30C44-01, TM-E30S46-A1 and TM-E30C46-A1.

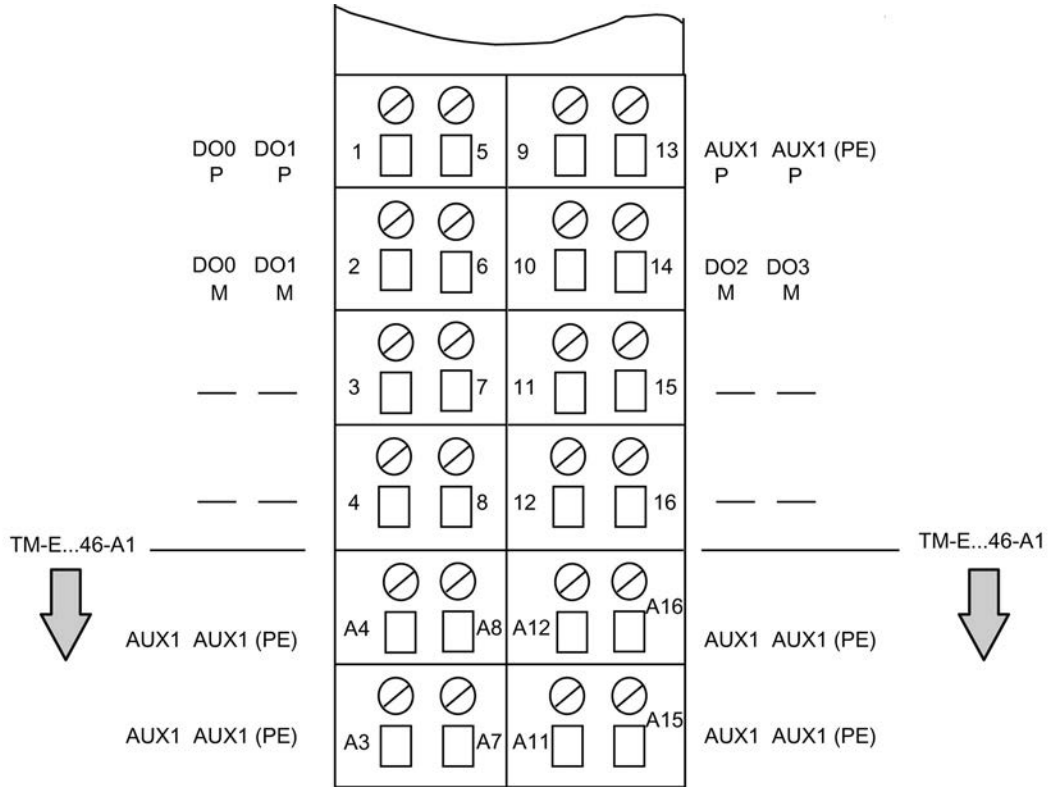

DOx P: Terminal for fail-safe digital output (P/M switching)

DOx M: Terminal for fail-safe digital output (P/M switching)

At TM-E...46-A1: AUX 1 bus implemented. Connection to terminals A3 to A16 for any connection of PE (individual grouping of load current power supplies possible)

Figure 7-49 Terminal Assignment of TM-E...44-01/TM-E...46-A1 for EM 4 F-DO DC24V/2A PROFIsafe

See also

Properties of the PM-E F pm DC24V PROFIsafe Power Module (Page 77)

7.7.3 Wiring diagram of the EM 4 F-DO DC24V/2A PROFIsafe

Block Diagram

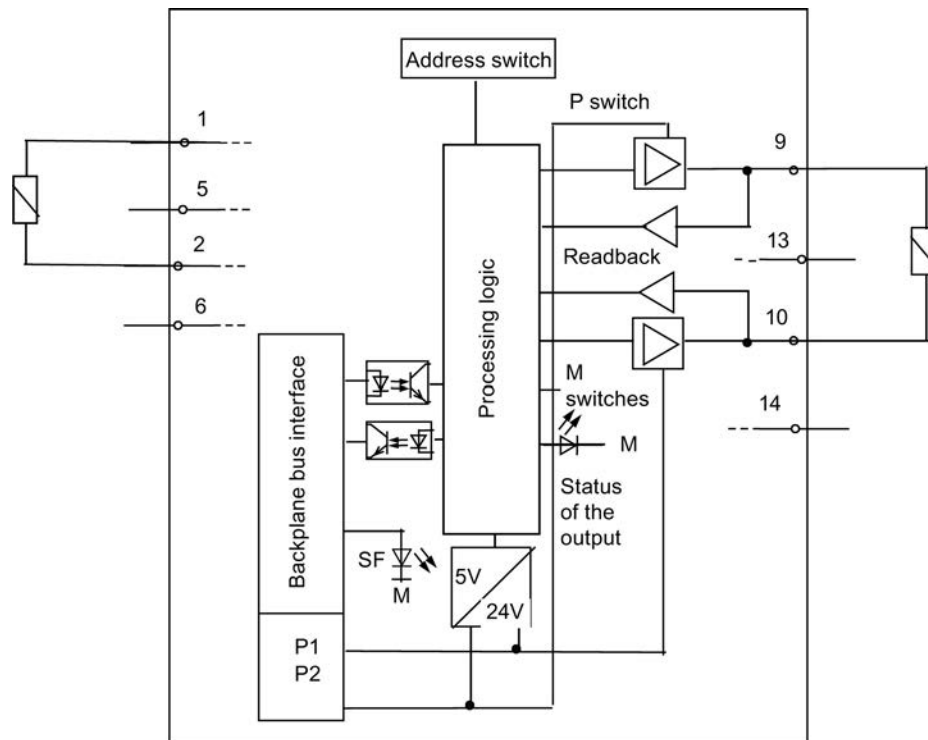

Figure 7-50 Block diagram of the EM 4 F-DO DC24V/2A PROFIsafe

Application 1: Wiring a load to each digital output

Each of the four fail-safe digital outputs consists of a DOx P P-switch and a DOx M M-switch. You connect the load between the P and M-switches. To ensure voltage is applied to the load, both switches are always activated. This configuration achieves safety class SIL3/Category 4/PLe.

The wiring is carried out on an appropriate terminal module.

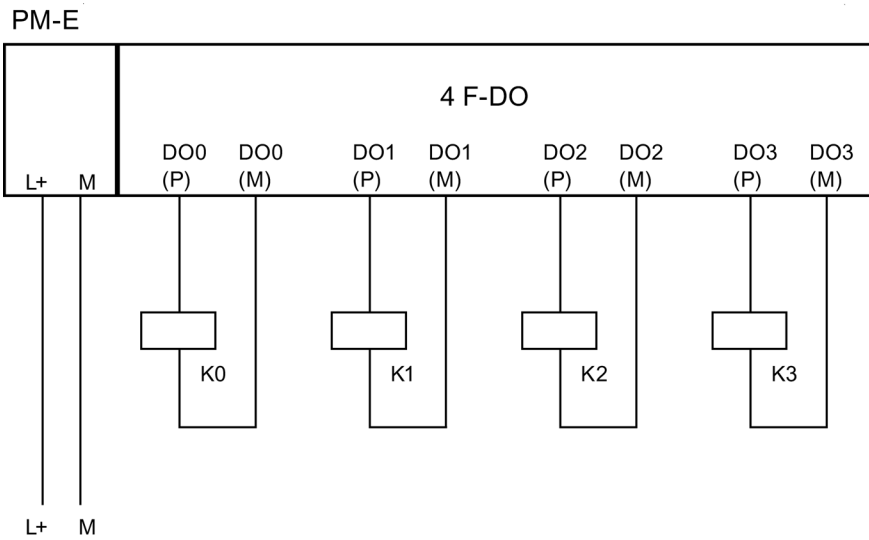

Figure 7-51 Wiring diagram of the EM 4 F-DO DC24V/2A PROFIsafe

| |
|---|
| ⚠ WARNING |
| In order to achieve SIL3/Category 4/PLe with this wiring, you must install a suitably-qualified sensor, for example in accordance with IEC 60947. |

Application 2: Wiring loads to L+ and M at each digital output

You can connect two relays using one fail-safe digital output. The following conditions should be kept in mind:

- L+ and M of the relays must be connected with L+ and M of the F-DO module (reference potential must be equal).
- The normally open contacts of the two relays must be connected in series.

A connection to each of the four digital outputs is possible. The figure below shows an example of the connection to DO0. This configuration achieves safety class SIL3/Category 4/PLe (process status readback required).

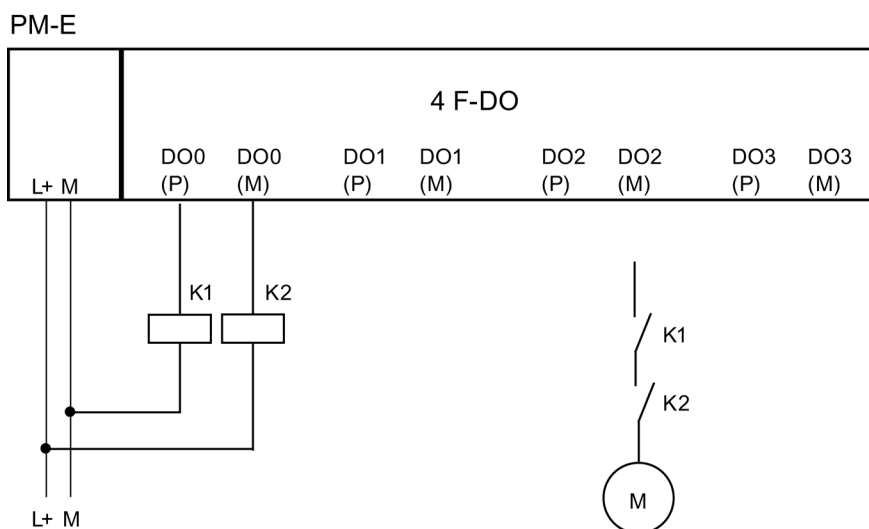

Figure 7-52 Wiring diagram for in each case 2 relays on 1 F-DO of the EM 4 F-DO DC24V/2A PROFIsafe

⚠ WARNING

When connecting two relays on one digital output, (as shown in the figure above), the errors "wire break" and "overload" are detected only at the P-switch (not at the M-switch).

⚠ WARNING

The controlled actuator can no longer be switched off should a cross circuit occur between the P and M-switches of the output. To avoid cross circuits between the P and M-switches of a fail-safe digital output, you should always wire the relay connection to the P and M-switches separately, in order to prevent any cross circuits (for example with separately-sheathed cables or using separate cable ducts).

Note

The EM 4 F-DO DC24V/2A PROFIsafe carries out a bit pattern test every 15 minutes or so. The module then sends an impulse for max. 4 ms. This test is run with a time offset between the P and M-switches in order to prevent the actuator from being activated. This impulse may cause the corresponding relay to tighten, which may reduce its service life.

We therefore recommend adhering to the wiring scheme detailed below.

Application 3: Wiring two loads in parallel to each digital output

Avoiding/Managing Cross Circuits:

To protect against cross-circuits between P and M-switches in fail-safe digital outputs, we recommend the following wiring scheme. This configuration achieves safety class SIL3/Category 4/PLe.

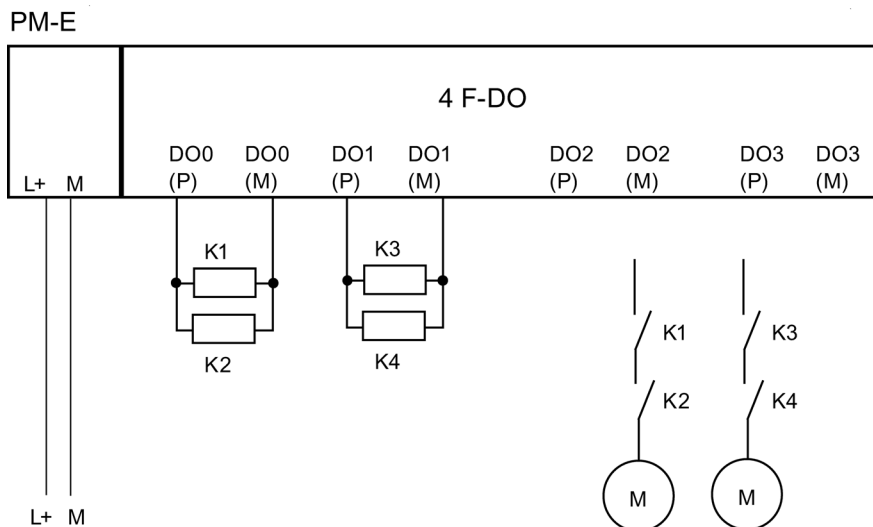

Figure 7-53 Wiring diagram for in each case 2 relays parallel on 1 F-DO of the EM 4 F-DO DC24V/2A PROFIsafe

Note

With a parallel connection of two relays on one digital output (as shown above) the "wire break" fault is only detected if the wire break disconnects both relays from P or M. This diagnosis is not safety-related.

7.7.4 Parameters of the EM 4 F-DO DC24V/2A PROFIsafe

Parameters in STEP 7

The table below lists the parameters that can be assigned for the F-DO module (see also "Configuring and programming").

Table 7- 35 Parameters of the F-DO Module

| Parameter | Range | Default | Type of Parameter | Effective Range |
|--|---|-----------------------------|-------------------|-----------------|
| F-Parameters: | | | | |
| F_destination_address | 1 to 1022 | is assigned by STEP 7 | Static | Module |
| F monitoring time | 10 to 10,000 ms | 150 ms | Static | Module |
| Module Parameters: | | | | |
| Behavior after channel faults* | Passivate the entire module/Passivate the channel | Passivate the entire module | Static | Module |
| DO channel n | Activated/deactivated | Activated | Static | Channel |
| Readback time | 1 to 400 ms | 1 ms | Static | Channel |
| Diagnostics: Wire break | Activated/deactivated | Deactivated | Static | Channel |
| * This setting is only relevant when <i>S7 Distributed Safety V5.4</i> or higher is installed. | | | | |

Readback Time Parameter

Each output channel has its own selectable readback time. This time specifies the maximum duration of the turn off test for the corresponding channel and therefore also the readback time for turning off the channel.

The following readback times can be set: 1 ms, 5 ms, 10 ms, 50 ms, 100 ms, 200 ms and 400 ms.

You should set an adequately high readback time if the channel involved switches high capacitive loads. If the readback time for a controlled capacitive load is set too low, the output channel is passivated because the discharge of the capacitance does not take place within the turn off test.

If the readback signals are incorrect, the "short-circuit" fault only causes passivation of the output channel after the readback time has elapsed.

| |
|--|
|  WARNING |
| With a configured readback time of ≥ 50 ms, short-circuits (cross circuits) can be suppressed with an interference signal with a frequency > 10 Hz (50:50 duty cycle). Short-circuits (cross-circuits) on an output of the same module will be detected. |

Effects of parameter changes on the bit pattern test

The duration of a test pulse in the dark test depends on the load and is less than or equal to the configured readback time.
 You can find detailed information about the bit pattern test for the fail-safe ET 200S modules, the response of the employed modules and the available parameters on the Internet (<http://support.automation.siemens.com/WW/view/en/44452714>).

7.7.5 Diagnostic Functions of the EM 4 F-DO DC24V/2 A PROFIsafe

Behavior in case of supply voltage failure

In the case of a voltage dip in the external auxiliary voltage, the SF LED lights up, the module is passivated.

With the subsequent supply recovery (level must remain above the specified value for at least 1 minute (refer to the technical specifications: voltages, currents, electrical potentials)) the SF LED goes out again, the module remains passivated. The SF LED flashes if there are no other errors, until the error is acknowledged.

Diagnostic functions

The table below provides an overview of the diagnostic functions of the EM 4 F-DO DC24V/2A PROFIsafe. The diagnostic functions are assigned either to one channel or to the entire module.

Table 7- 36 Diagnostic functions of the EM 4 F-DO DC24V/2A PROFIsafe

| Diagnostic Function* | Fault Number | LED | Effective Range of Diagnostics | Can be Assigned Parameters |
|--|-----------------|-----|--------------------------------|----------------------------|
| Short-circuit | 1 _H | SF | Channel | No |
| Overload | 4 _H | SF | Channel | No |
| Overtemperature | 5 _H | SF | Module | No |
| Wire break | 6 _H | SF | Channel | Yes |
| Fault | 9 _H | SF | Module | No |
| Parameter assignment error | 10 _H | SF | Module | No |
| Sensor voltage or load voltage missing | 11 _H | SF | Module | No |
| Communication error | 13 _H | SF | Module | No |
| *: special for fail-safe modules; display in <i>STEP 7</i> , see Table 5-1 Fault types of channel-related diagnostics (apart from EM 1 F-RO DC24V/AC24..230V/5A) (Page 58) | | | | |

| |
|---|
|  WARNING |
| Before acknowledging the short-circuit diagnosis, remedy the respective error and validate your safety function. In this case, follow the steps described in section "Reactions to Faults (Page 53)". |

Causes of Faults and Corrective Measures

The following table contains the possible causes of faults and their corrective measures for the individual diagnostic messages and diagnostic buffer entries of electronic module 4 F-DO DC24V/2A PROFIsafe.

Table 7- 37 Diagnostic messages and diagnostic buffer entries of the EM 4 F-DO Ex 17,4V/40mA, causes of errors and remedies

| Diagnostic Message | Diagnostics buffer | Possible Causes | Corrective Measures |
|---------------------------------------|---|---|---|
| Short-circuit | Defective P-output driver | Short-circuit of the output | Eliminate the short-circuit within 100 hours after the error has occurred. |
| | | Short-circuit between channels with different signals | Eliminate the short-circuit within 100 hours after the error has occurred. |
| | | Defective output driver | Replace module |
| | Defective M-output driver | Short-circuit of the output | Eliminate the short-circuit within 100 hours after the error has occurred. |
| | | Short-circuit between channels with different signals | Eliminate the short-circuit within 100 hours after the error has occurred. |
| | | Defective output driver | Replace module |
| | Short-circuit of output to L+, or defective output driver | Short-circuit of the output | Eliminate the short-circuit within 100 hours after the error has occurred. |
| | | Short-circuit between channels with different signals | Eliminate the short-circuit within 100 hours after the error has occurred. |
| | | Defective output driver | Replace module |
| | Short-circuit of output to M, or output driver failure | Output overload | Eliminate the overload within 100 hours after the error has occurred. |
| | | Short-circuit of output to M | Eliminate the short-circuit within 100 hours after the error has occurred. |
| | | Defective output driver | Replace module |
| Overload (for "1" output signal only) | Overcurrent at output driver | Overload at output | Eliminate overload |
| Overtemperature | Temperature outside the permitted range | Shutdown due to violation of high or low temperature limit value in the module case | Check the ambient temperature. Once the fault has been eliminated, the module must be removed and inserted or the power switched off and on |

| Diagnostic Message | Diagnostics buffer | Possible Causes | Corrective Measures | |
|---|--|--|---|---|
| Wire break (for "1" output signal only) ¹⁾ | Wire break | Wire break between the module and actuator | Reestablish the cable connection | |
| | | Channel not connected (open) | Disable the parameter setting "Diagnostics: Wire break" for the channel | |
| | | Short-circuit between channels with different signals | Eliminate the short-circuit | |
| Fault | Processor failure | Electromagnetic interference has exceeded limits | Eliminate the interference. Once the fault has been eliminated, the module must be removed and inserted or the power switched off and on. | |
| | | Internal error | Replace module | |
| | | Setting of the address switch (DIP switch) not as expected | Check and correct DIP switch settings | |
| | Processor error | Electromagnetic interference has exceeded limits | Eliminate the interference. Once the fault has been eliminated, the module must be removed and inserted or the power switched off and on. | |
| | | Internal error | Replace module | |
| | EPROM fault | Electromagnetic interference has exceeded limits | Eliminate the interference. Once the fault has been eliminated, the module must be removed and inserted or the power switched off and on. | |
| | | Internal error | Replace module | |
| | RAM fault | Electromagnetic interference has exceeded limits | Eliminate the interference. Once the fault has been eliminated, the module must be removed and inserted or the power switched off and on. | |
| | | Internal error | Replace module | |
| | Time monitoring activated | PROFIsafe monitoring time set too low | Set a higher value for the "F monitoring time" parameter for the module | |
| | Parameter assignment error | Parameter assignment error (19, 20, 21) | Faulty parameter assignment | Check communication paths Correct the parameters |
| | | Parameter assignment error (18) | PROFIsafe address set incorrectly in the F-module | Check whether the PROFIsafe address on the fail-safe module matches the configuration |
| Sensor voltage or load voltage missing | Internal supply voltage of the module failed | Electromagnetic interference has exceeded limits | Eliminate the interference. Once the fault has been eliminated, the module must be removed and inserted or the power switched off and on. | |
| | | Internal supply voltage error | Replace module | |

| Diagnostic Message | Diagnostics buffer | Possible Causes | Corrective Measures |
|---------------------|---|--|---|
| Communication error | Cyclic redundancy check (CRC) error in data message frame | Communication interference between the F-CPU and the fail-safe module, e.g., due to electromagnetic interference in excess of limits or sign-of-life monitoring error. | Check the PROFIBUS/PROFINET connection Eliminate the interference |
| | | Write access to the I/O area for module inputs and outputs in the standard user program. | Remove the write accesses to the I/O area for module inputs and outputs of the F-module in the standard user program. |
| | Monitoring time for data message frame exceeded | Assigned monitoring time exceeded | Check the monitoring time parameter assignment |
| | | | Once the fault is eliminated, the F-module must be reintegrated in the safety program. |

You can find detailed information on F I/O passivation and reintegration under "*Diagnostics*" in the *S7 Distributed Safety, Configuring and Programming* manual or the *S7 F/FH Systems, Configuring and Programming* manual.

Generally Applicable Information on Diagnostics

For information on diagnostics that affects all fail-safe modules (such as reading diagnostic functions; passivation of channels) see this manual in "*Diagnostics*" and the *S7 Distributed Safety, Configuration and Programming* manual or *S7 F/FH Systems, Configuring and Programming*.

See also

Fault Diagnostics (Page 55)

7.7.6 Technical Specifications of the EM 4 F-DO DC24V/2A PROFIsafe

Overview

| Technical specifications | |
|---|-----------------------------|
| Dimensions and weight | |
| Dimensions W x H x D (mm) | 30 x 81 x 52 |
| Weight | Approx. 85 g |
| Data for Specific Module | |
| Number of outputs (P/M switching) | 4 |
| Assigned address area | |
| • I/O area for inputs | 5 bytes |
| • I/O area for outputs | 5 bytes |
| Length of cable* | |
| • Unshielded | max. 500 m |
| • Shielded | max. 500 m |
| Maximum achievable safety class | |
| • in accordance with IEC 61508:2000 | SIL3 |
| • in accordance with ISO 13849-1:2006 or EN ISO 13849-1:2008 | Cat.4/PLe |
| Safety characteristics | SIL3 |
| • Low demand mode (average probability of failure on demand) | < 1.00E-05 |
| • High demand/continuous mode (probability of a dangerous failure per hour) | < 1.00E-10 |
| • Acceptance ID | FM, cULus, ATEX, CE, C-Tick |
| Voltages, Currents, Potentials | |
| Rated supply voltage L+ | 24 VDC |
| • permissible range ** | 20.4 V to 28.8 V |
| • Power loss ride-through of L+ | None |
| • Mains buffering of internal voltage supply | 5 ms |
| • Reverse polarity protection | No |
| Total current of outputs | |
| • Horizontal installation | |
| – Up to 40 °C | 6 A |
| – Up to 55 °C | 5 A |
| – Up to 60 °C | 4 A |
| • Vertical installation | |
| – Up to 40 °C | 4 A |

| Technical specifications | |
|--|--|
| Electrical isolation | |
| • Between channels and backplane bus | Yes |
| • Between channels and power supply | No |
| • Between channels | No |
| • Between channels/power supply and shield | Yes |
| Permissible potential difference between | |
| • Shield and ET 200S bus connection | 75 V DC/60 V AC |
| • Shield and I/O (DOs, P1/P2 buses) | 75 V DC/60 V AC |
| • ET 200S bus connection and I/O (DOs, P1/P2 buses) | 250 V AC |
| Isolation in the series tested with | |
| • ET 200S bus connection against I/O (DOs, P1/P2 buses) | 2545 V DC/2 s |
| Isolation in the type test tested with | |
| • Shield and ET 200S bus connection | 350 V AC/1 min |
| • Shield against I/O (DOs, P1/P2 buses) | 350 V AC/1 min |
| • ET 200S bus connection against I/O (DOs, P1/P2 buses) | 2830 V AC/1 min |
| • Surge voltage test between ET 200S bus connection and I/O (DOs, P1/P2 buses) | 6000 V DC/5 positive and 5 negative pulses |
| Current consumption | |
| • From backplane bus | 28 mA, maximum |
| • From load voltage L+ (without load) | 100 mA, typical |
| Power loss of the module | 3.5 W, typical |
| Status, interrupts, diagnostics | |
| Status display | |
| Outputs | Green LED per channel |
| Diagnostic functions | |
| • Group fault display | Red LED (SF) |
| • Diagnostic information can be displayed | Possible |
| Data for selecting an actuator*** | |
| Output voltage | |
| • For "1" signal | <ul style="list-style-type: none"> • Minimum L+ (-2.0 V) • P-switch: Minimum L+ (-1.5 V); voltage drop in M-switch: 0.5 V, maximum |

| Technical specifications | |
|--|--|
| Output current for "1" signal | |
| • Rated value | 2 A |
| • Permissible range | 20 mA to 2.4 A |
| For "0" signal (residual current) | 0.5 mA, maximum |
| Indirect control of load by means of interface relay: | |
| For "0" signal (residual current) | |
| • P-switch | 0.5 mA, maximum |
| • M-switch | 0.5 mA, maximum |
| Load resistance range | 12 Ω to 1 kΩ |
| Lamp load | 10 W, maximum |
| Wire break monitoring (open load detection) and overload monitoring | |
| • Response threshold | $I < 4$ to 19 mA |
| • Fault detection time | depending on the selected readback time (see "Response times") |
| Parallel connection of 2 outputs | Not possible |
| Control of a digital input | Not possible |
| Switching frequency | |
| • With resistive load | 30 Hz symmetrical, maximum |
| • With inductive load in accordance with IEC 60947-5-1, DC13 | 0.1 Hz symmetrical, maximum |
| • With lamp load | 10 Hz symmetrical, maximum |
| Voltage induced on current interruption limited to | -80 V, typical |
| Short-circuit protection of output | Yes, electronic |
| • Response threshold (short-circuit) | 5 A to 12 A |
| • Response threshold (external M-short-circuit) | 5 A to 12 A |
| • Response threshold (external P-short-circuit) | 25 A to 45 A |
| Overload protection | Yes |
| • Response threshold | $I > 2.6$ A to 2.8 A |
| Time, Frequency | |
| Internal processing times | See "Response times" |
| Acknowledgment time in safety mode | 4 ms minimum/8 ms maximum |
| Protection against overvoltage | |
| Protection of power supply L+ from surge in accordance with IEC 61000-4-5 with external protection elements only | |
| • Symmetrical (L+ to M) | + 1 kV; 1.2/50 μs |
| • Asymmetrical (L+ to PE, M to PE) | + 2 kV; 1.2/50 μs |

| Technical specifications | |
|---|-----------------------|
| Protection of inputs and outputs from surge in accordance with IEC 61000-4-5 with external protection elements only | |
| • Symmetrical (L+ to M) | +1 kV; 1.2/50 μ s |
| • Asymmetrical (L+ to PE, M to PE) | +2 kV; 1.2/50 μ s |
| <p>*: In order to achieve the specified cable length, you must route the P and M-signal lines in a cable or a sheathed cable.</p> <p>**: Operating below the permissible supply voltage is only permissible for the repair time. See section "Introduction (Page 75)".</p> <p>Operating above the permissible supply voltage: At a supply voltage > 35.5 V, the module switches off.</p> <p>***: For more information on the requirements for encoders and actuators, refer to the section "Wiring and Fitting Modules (Page 45)".</p> | |

7.8 1 F-RO DC24V/AC24..230V/5A Digital Electronic Module

7.8.1 Properties of the EM 1 F-RO DC24V/AC24..230V/5A

Order Number

6ES7138-4FR00-0AA0

Properties

The 1 F-RO DC24V/AC24..230V/5A digital electronic module disposes of the following properties:

- 1 relay output (2 2-channel contacts)
- Output current 5 A
- Rated load voltage 24 VDC and 24 VAC to 230 VAC
- Status display for output (green LED)
- safety class SIL3/Category 4/PLe can be achieved if the F-RO module is controlled by a fail-safe output (for example, by EM 4F-DO DC24V/2A PROFIsafe)

Safety-Related Shutdown of Standard Load Groups

In combination with the EM 4 F-DO DC24V/2A PROFIsafe, the 1 F-RO DC24V/AC24..230V/5A electronic module can be used for safety-related shutdown of standard load groups Last (consisting of standard power module and standard output modules) (control of F-RO module performed via fail-safe output). If no more than 2 A current are required, the safety-related shutdown of standard load groups is made directly with the P/M-switching EM 4 F-DO DC24V/2A PROFIsafe.

Refer to the Internet (<http://support.automation.siemens.com/WW/view/en/39198632>) for a list of released standard ET 200S output modules.

WARNING

Safety-related activation of standard DO module outputs is not possible. Only safety-related **shutdown** is possible. The following issues must therefore be taken into consideration:

In the worst case, you must consider all possible faults of the standard DO modules and the programs controlling them for which the faults cannot be found directly. For example, the EM 1 F-RO DC24V/AC24..230V/5A does not detect external short-circuits to L+ at the standard DO module outputs. All faults developing at the standard DO modules influence the process via final controlling elements. The process status must be made known to the F-CPU by way of sensors and a suitable safety program.

Diagnostic functions must be handled indirectly in the controlled process since the self-test function of standard DO modules cannot be used to detect safety-critical faults: The safety control function does not intervene in the faulty process as long as hazards can be excluded. However, it shuts down the system if the process develops unwanted or potentially dangerous activities.

Consequently, instead of the short fault reaction times defined in S7, the reaction time to internal faults in standard DO modules is determined by the controlled process and its corresponding feedback signals.

Safety-related process values must be

- safely
- read in by way of fail-safe input modules (e.g. F-DI),
- prepared by the F-CPU for output commands and
- output at the fail-safe output module for shutdown of the corresponding safety relay or
- output at the fail-safe power module PM-E F.

If the process does not respond as expected due to malfunctions within a process or faulty standard DO modules, these standard DO modules must be set to safe state by way of the higher-level safety circuit.

The process safety time is of particular importance here. Risks due to any malfunctions within the process control system can be ruled out within this process safety time.

The safety program must react in a safety-related and logically suitable fashion to unwanted or potentially dangerous states in the process via the EM 1 F-RO DC24V/AC24..230V/5A and fail-safe output modules.

If you want to completely avoid the problems described above, we recommend you use P/M-switching fail-safe electronic module 4 F-DO DC24V/2A PROFIsafe with standard ET 200S power modules (see "Digital electronic module 4 F-DO DC24V/2A PROFIsafe" and the table "Assigning power modules to electronic modules / motor starters and safety class").

Property of safety-related shutdown of standard DO modules with the EM 4 F-DO DC24V/2A PROFIsafe in combination with EM 1 F-RO DC24V/AC24...230V/5A:

This cost-effective solution allows the full and simultaneous shutdown of all outputs involved when a fault is detected in the process or on the EM 1 F-RO DC24V/AC24...230V/5A.

Property of the individual shutdown of F-modules with fail-safe outputs:

The scope of shutdown is kept to a minimum when a fault is detected. It is also possible to react to critical process states staggered over time, or to perform safety-related shutdown of individual outputs.

7.8.2 Terminal assignment of EM 1F-RO DC24V/AC24...230V/5A

Front view

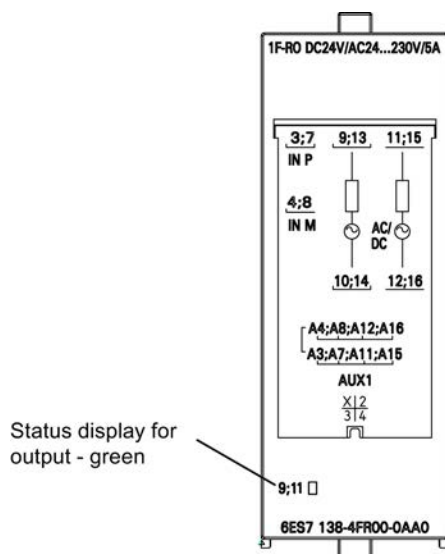

Figure 7-54 Front view EM 1 F-RO DC24V/AC24...230V/5A

! WARNING

The status display of the output is not designed for safety-related functions and may therefore not be evaluated for safety-related activities.

Terminal assignment

The figure below shows the terminal assignment of the EM 1 F-RO DC24V/AC24..230V/5A for the supported terminal module TM-E30S44-01, TM-E30C44-01, TM-E30S46-A1 and TM-E30C46-A1.

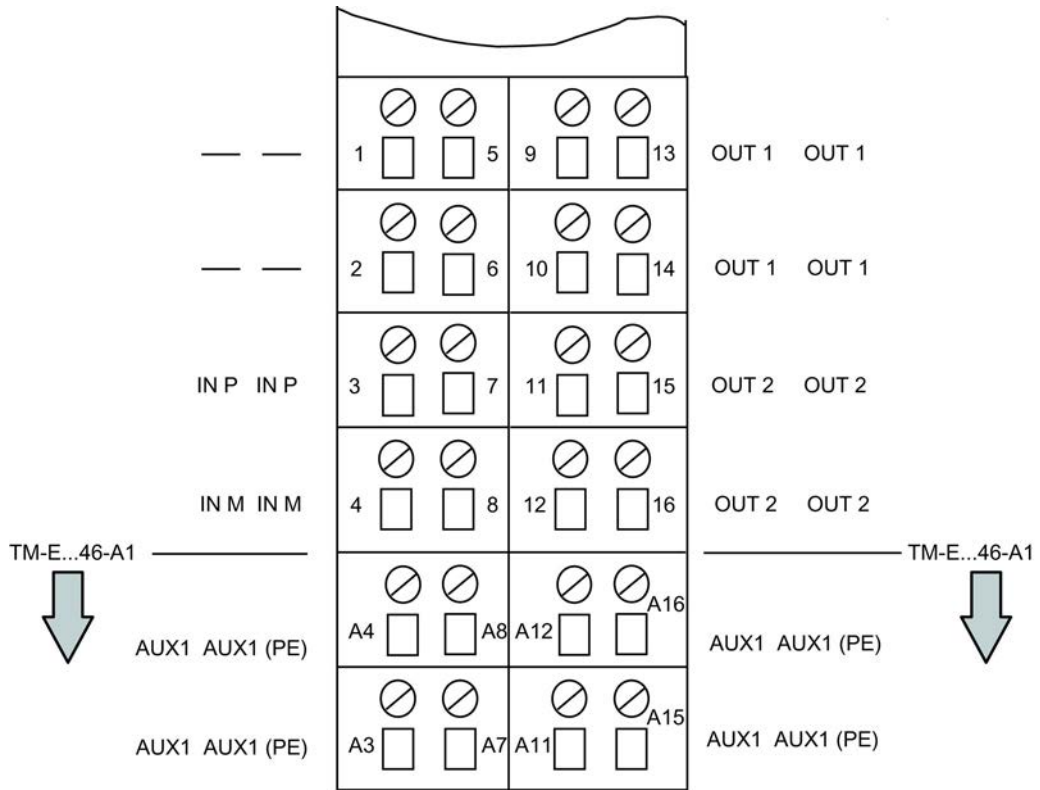

Figure 7-55 Terminal assignment TM-E...44-01/TM-E...46-A1 for EM 1 F-RO DC24V/AC24..230V/5A

Table 7- 38 Terminal assignment of the TM-E...44-01/TM-E...46-A1

| Terminal | | Designation |
|----------|-------|---|
| 3 | IN P | Terminal for 24 VDC control voltage |
| 4 | IN M | Terminal for control voltage ground |
| A4 | AUX 1 | At TM-E...46-A1: AUX 1 bus implemented. Connection to terminals A3 to A16 for any PE connection. Individual grouping of load current supplies is supported. |
| A3 | AUX 1 | At TM-E...46-A1: AUX 1 bus implemented. Connection to terminals A3 to A16 for any PE connection. Individual grouping of load current supplies is supported. |
| 7 | IN P | Terminal for 24 VDC control voltage |
| 8 | IN M | Terminal for control voltage ground |
| A8 | AUX 1 | At TM-E...46-A1: AUX 1 bus implemented. Connection to terminals A3 to A16 for any PE connection. Individual grouping of load current supplies is supported. |

| Terminal | | Designation |
|----------|-------|--|
| A7 | AUX 1 | At TM-E...46-A1: AUX 1 bus implemented. Connection to terminals A3 to A16 for any PE connection. Individual grouping of load current supplies is supported. |
| 9 | OUT 1 | NO contact, channel 0 for fail-safe switching of load 1 |
| 10 | OUT 1 | |
| 11 | OUT 2 | NO contact, channel 1 for fail-safe switching of load 2 |
| 12 | OUT 2 | |
| A12 | AUX 1 | At TM-E...46-A1: AUX 1 bus implemented. Connection to terminals A3 to A16 for any PE connection. Individual grouping of load current supplies is supported. |
| A11 | AUX 1 | At TM-E...46-A1: AUX 1 bus implemented. Connection to terminals A3 to A16 for any PE connection. Individual grouping of load current supplies is supported. |
| 13 | OUT 1 | NO contact, channel 0 for fail-safe switching of load 1 |
| 14 | OUT 1 | |
| 15 | OUT 2 | NO contact, channel 1 for fail-safe switching of load 2 |
| 16 | OUT 2 | |
| A16 | AUX 1 | At TM-E...46-A1: AUX 1 bus implemented. Connection to terminals A3 to A16 for any PE connection. Individual grouping of load current supplies is supported. |
| A15 | AUX 1 | At TM-E...46-A1: AUX 1 bus implemented. Connection to terminals A3 to A16 for any PE connection. Individual grouping of load current supplies is supported. |

 **CAUTION**

Wire these terminals in parallel if high currents are generated at OUT 1 or OUT 2 ($\geq 50\%$ of the rated current of the respective output channel):

- For OUT 1: Terminals 9/10 and 13/14
- For OUT 2: Terminals 11/12 and 15/16

Otherwise, high current loads may cause the terminals to heat up.

7.8.3 Wiring of EM 1 F-RO DC24V/AC24..230V/5A

Block Diagram

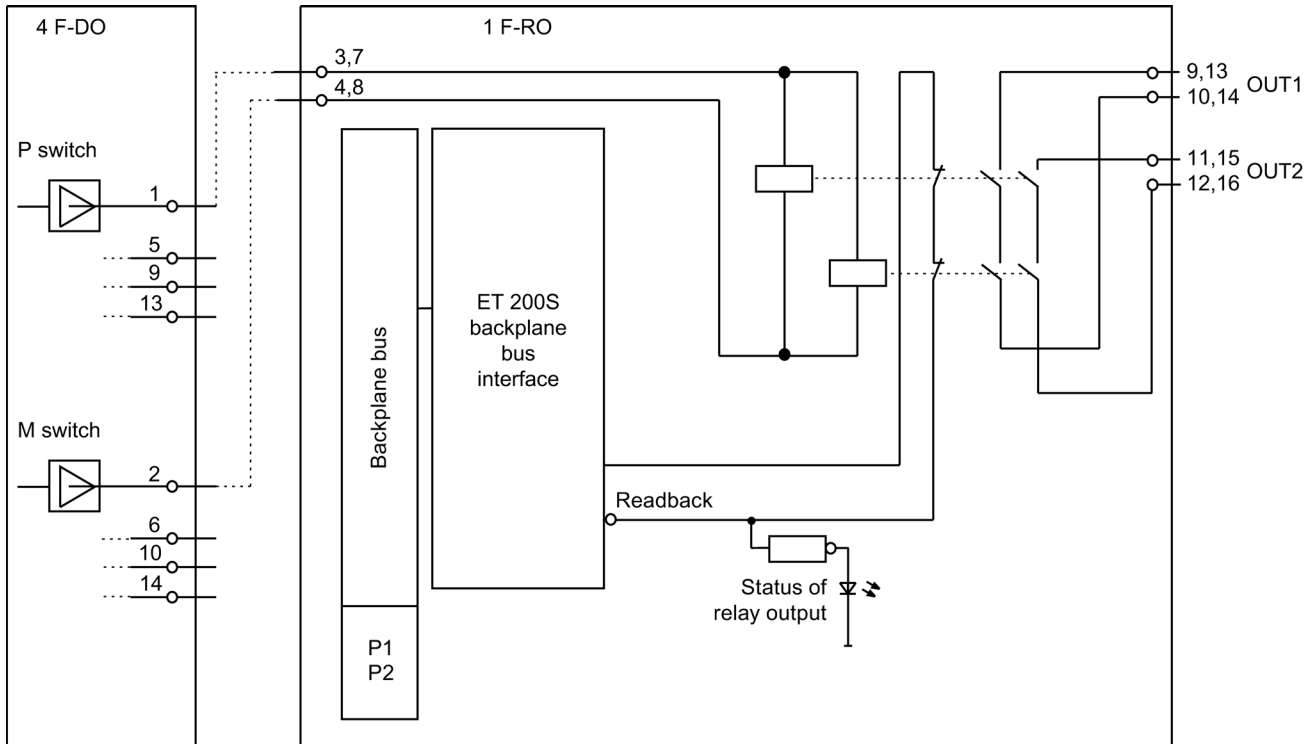

Figure 7-56 Block diagram of the EM 1 F-RO DC24V/AC24..230V/5A

Wiring Diagram

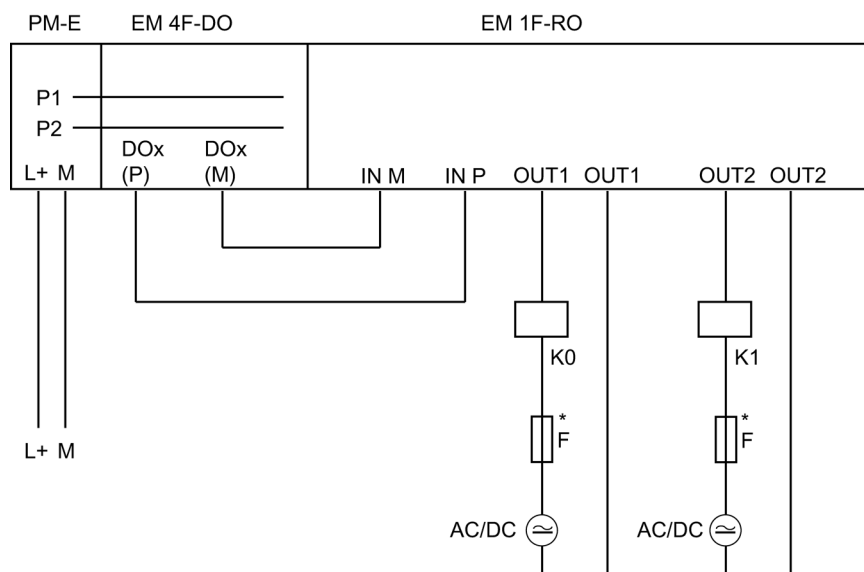

Figure 7-57 Wiring diagram of the EM 1 F-RO DC24V/AC24..230V/5A

! WARNING

* Please always install an external fuse with the following properties in order to protect the relay contacts against overload and short-circuits: Fusible cut-out, 6 A, operating class gL/gG.

Note that for applications in accordance with EN 50156-1, the specified rated current of the overcurrent protective device must be multiplied by the safety factor 0.6 to rule out the error "non-opening of contact elements due to permanent contact welding".

Wiring the 24 VDC power supply

Apply the 24 VDC control voltage to IN P (terminals 3;7) and IN M (terminals 4;8). The 24 VDC line is usually connected via a PM-switching fail-safe output (e.g. EM 4 F-DO DC24V/2A PROFIsafe). Wire the P-output of F-DO to IN P and the M-output to IN M of the F-RO module.

You can also wire the circuit using a PP-switching fail-safe output. However, note that external short-circuits to P at the P input cannot be controlled. In this case IN M would be connected directly to the control voltage ground.

Wiring the Load Voltage and the Load

The connections of the relay output features electrically isolated NO contacts. This means that power must be fed to these contacts from an external source. Connect the load supply (supply 1) and the load (load 1) in series to the connections OUT 1 (terminals 9;13)/(terminals 10;14). This circuit ensures that the NO contacts of the relay reliably cut off power to the load voltage supply. This redundant series circuit of the relay contacts allows shutdown if one of the two relays fails.

The two circuits are not electrically interdependent. They are logically interconnected by way of common control. This means that the potential in the OUT 2 (terminals 11;15)/(terminals 12;16), supply 2 and load 2 electric circuit may be different.

| |
|--|
|  WARNING |
|--|

| |
|--|
| If you have connected extra low voltage (SELV/PELV) to one channel, then the other channel of the F-RO module must also be connected to extra low voltage. |
|--|

Information on the F-RO module and the current TÜV certificate are available on the Internet (<http://support.automation.siemens.com/WW/view/en/12461959/133300>).

Note

Sporadic passivation of fail-safe modules during load shedding via the F-RO module

If you switch off a load within an ET 200S station via the safety-related electronic module 1F-RO, passivation of all fail-safe modules within this ET 200S station may sometimes occur.

The passivation of the fail-safe modules is triggered by power surges, which may occur, for example, when switching off inductive loads.

Install a surge suppressor for the DC and AC coils, as is also used to increase service life of relay contacts. You can find a description of these suppressors on the Internet (<http://support.automation.siemens.com/WW/view/en/25520973>).

Reading back the relay contacts

Always compare the readback value returned from the F-RO module with the control status in the safety program. The S7 Distributed Safety F-systems provide an F-application block FB 216 "F_FDBACK" for this purpose: You can use the "Feedback circuit monitoring" in your safety program (see the *S7 Distributed Safety, Configuring and Programming* manual).

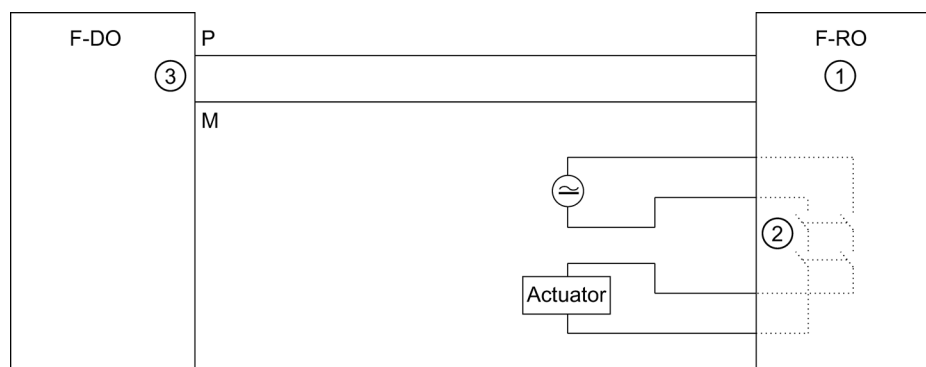

- ① F-RO with Integrated FEEDBACK input
- ② Relay contacts for switching the load
- ③ Output Q

Figure 7-58 Example of an interconnection with F-application block FB 216

If the 24 VDC control voltage falls below the required value for relay pick-up or the wire to the input connections breaks, the relays will be released and "0" will be read back instead of "1." This fault is only detected if the control voltage is switched on.

The value "1" is read back from the module if one of the two relays gets stuck (NO contacts remain closed). The fault is detected by comparing this readback value with the expected value "0" in the safety program. This fault is only detected if the control voltage is switched off.

Note

SIL3/Cat.4/PLe requires the readback of process states and at least yearly signal changes. We recommend that you execute the signal changes at six-month intervals.

7.8.4 Diagnostic functions of EM 1 F-RO DC24V/AC24..230V/5A

Output status display

Behavior of the output status display at the F-RO module:

- Relay not activated: LED is not lit
- Relay is activated: LED is lit
- Relay not activated and relay contact welded: LED is lit

Causes of Faults and Corrective Measures

In S7 Distributed Safety F-systems you can run diagnostics by evaluating output "DIAG" of FB 216 "F_FDBACK" when using this F-application block in your safety program to read back the relay contacts (refer to the *S7 Distributed Safety, Configuring and Programming* manual).

7.8.5 Technical specifications of the EM 1 F-RO DC24V/AC24..230V/5A

Overview

| Technical specifications | |
|--|----------------|
| Dimensions and weight | |
| Dimensions W x H x D (mm) | 30 x 81 x 52 |
| Weight | Approx. 90 g |
| Data for Specific Module | |
| Number of outputs | |
| • Relay outputs | 1 (2 channels) |
| Assigned address area | |
| • In the I/O area for inputs | 2 bits |
| • In the I/O area for outputs | -- |
| Length of cable | |
| • Unshielded for load contact | 200 m, maximum |
| • Shielded for load contact | 200 m, maximum |
| • Control cable (input) | 10 m, maximum |
| Maximum achievable safety class | |
| • in accordance with IEC 61508:2000 | SIL3 |
| • in accordance with ISO 13849-1:2006 or EN ISO 13849-1:2008 | Cat.4/PLe |

| Technical specifications | |
|--|---|
| Safety characteristics | SIL3 |
| <ul style="list-style-type: none"> Low demand mode (average probability of failure on demand) | < 1.00E-05 |
| <ul style="list-style-type: none"> High demand/continuous mode (probability of a dangerous failure per hour) | < 1.00E-09 |
| <ul style="list-style-type: none"> Acceptance ID | cULus, CE, C-Tick |
| Voltages, Currents, Potentials | |
| Control voltage | 20.4 to 28.8 VDC (supplied from fail-safe output of an F-DO) |
| Total current at both channels | |
| <ul style="list-style-type: none"> Horizontal installation <ul style="list-style-type: none"> Up to 40 °C Up to 50 °C Up to 60 °C | 8 A 6 A 5 A at max. control voltage 24.8 V DC 3 A at max. control voltage 28.8 VDC |
| <ul style="list-style-type: none"> Vertical installation <ul style="list-style-type: none"> Up to 40 °C | 6 A |
| Electrical isolation | |
| <ul style="list-style-type: none"> Between channels and backplane bus | Yes |
| <ul style="list-style-type: none"> Between channels and control voltage | Yes |
| <ul style="list-style-type: none"> Between channels | Yes |
| <ul style="list-style-type: none"> Between channels/control voltage and shield | Yes |
| Permissible potential difference between | |
| <ul style="list-style-type: none"> Shield and ET 200S bus connection | 75 V DC/60 V AC |
| <ul style="list-style-type: none"> Control voltage and shield | 75 V DC/60 V AC |
| <ul style="list-style-type: none"> ET 200S bus connection and control voltage | 75 V DC/60 V AC |
| <ul style="list-style-type: none"> Channel 1 and shield, ET 200S bus connection, control voltage, channel 2 | 250 V AC |
| <ul style="list-style-type: none"> Channel 2 and shield, ET 200S bus connection, control voltage, channel 1 | 250 V AC |
| Isolation in the series tested with | |
| <ul style="list-style-type: none"> Channel 1 against shield, ET 200S bus connection, control voltage, channel 2 | 2545 V DC/2 s |
| <ul style="list-style-type: none"> Channel 2 against shield, ET 200S bus connection, control voltage, channel 1 | 2545 V DC/2 s |

| Technical specifications | |
|--|---|
| Isolation in the type test tested with | |
| <ul style="list-style-type: none"> Shield against ET 200S bus connection, control input, channel 1, channel 2 | 370 VAC / 520 VDC / 1 min |
| <ul style="list-style-type: none"> Control input against ET 200S bus connection, shield, channel 1, channel 2 | 370 VAC / 520 VDC / 1 min |
| <ul style="list-style-type: none"> ET 200S bus connection against control voltage, shield, channel 1, channel 2 | 370 VAC / 520 VDC / 1 min |
| <ul style="list-style-type: none"> Channel 1 against shield, ET 200S bus connection, control voltage, channel 2 | 2300 VAC / 3250 VDC / 1 min |
| <ul style="list-style-type: none"> Channel 2 against shield, ET 200S bus connection, control voltage, channel 1 | 2300 VAC / 3250 VDC / 1 min |
| <ul style="list-style-type: none"> Surge test voltage between control voltage and channel 1, channel 2 | 7200 VDC/5 positive and 5 negative pulses |
| Current consumption | |
| <ul style="list-style-type: none"> From backplane bus | 10 mA, maximum |
| <ul style="list-style-type: none"> From control voltage (IN P, IN M) | 100 mA, maximum |
| Power loss of the module | 2.1 W, typical |
| Status, interrupts, diagnostics | |
| Status display | Green LED |
| Diagnostic functions | |
| <ul style="list-style-type: none"> Diagnostic information can be displayed | No |
| Data for Selecting an Actuator* | |
| Output current | |
| <ul style="list-style-type: none"> Continuous thermal current | Max. 5 A |
| <ul style="list-style-type: none"> Minimum load current | 5 mA |
| Contact protection (internal) | No |
| <ul style="list-style-type: none"> At the relay output | No |
| Wire break monitoring | No |
| Parallel connection of 2 outputs | Supported, observe max. total current |
| Control of a digital input | Possible |
| Switching frequency | |
| <ul style="list-style-type: none"> With resistive load | 2 Hz, maximum |
| <ul style="list-style-type: none"> With inductive load in accordance with IEC 60947-5-1, DC13 | 0.1 Hz, maximum |
| <ul style="list-style-type: none"> With inductive load in accordance with IEC 60947-5-1, AC15 | 2 Hz, maximum |
| <ul style="list-style-type: none"> Inductive load in accordance with UL 508 | Pilot Duty B300, R300 |
| Voltage induced on current interruption (internally) limited | No |

| Technical specifications | |
|---|---|
| Short-circuit protection of output | No, external fusible cut-out, 6 A, operating class gL/gG; with two outputs wired in parallel, each output must be fused with a 6 A fusible cut-out, operating class gL/gG. Note that for applications in accordance with EN 50156-1, the specified rated current of the overcurrent protective device must be multiplied by the safety factor 0.6 to rule out the error "non-opening of contact elements due to permanent contact welding". |
| Time, Frequency | |
| Switching time | Typically 13 ms |
| Release time | Typically 16 ms |
| Protection against overvoltage | |
| Protection of outputs from surge in accordance with IEC 61000-4-5 (no protection elements required) | |
| <ul style="list-style-type: none"> • Symmetrical <ul style="list-style-type: none"> – Channel 1 (9/13) against (10/14) – Channel 2 (11/15) against (12/16) | +1 kV; 1.2/50 μ s |
| <ul style="list-style-type: none"> • Asymmetrical <ul style="list-style-type: none"> – Channel 1 (9/13) or (10/14) against PE – Channel 2 (11/15) or (12/16) against PE | +2 kV; 1.2/50 μ s |
| *: For more information on the requirements for encoders and actuators, refer to the section "Wiring and Fitting Modules (Page 45)". | |

Switching Performance and Service Life of Contacts

The table below shows the switching performance and service life of contacts. You can extend the service life beyond the value indicated in the table by installing an external protective circuit.

Table 7- 39 Switching Performance and Service Life of Contacts

| Resistive Load | Voltage | Current | Duty cycle (typ.) NO contact |
|---|---------|---------|------------------------------|
| For resistive load | 24 VDC | 5.0 A | 0.35 million |
| | | 3.0 A | 0.5 million |
| | | 2.0 A | 0.75 million |
| | | 1.0 A | 1.8 million |
| | | 0.5 A | 4 million |
| | 230 VAC | 5.0 A | 0.1 million |
| | | 3.0 A | 0.15 million |
| | | 2.0 A | 0.2 million |
| | | 1.0 A | 0.4 million |
| | | 0.5 A | 0.8 million |
| For inductive load to IEC 60947-5-1 DC13/AC15 | 24 VDC | 1.0 A | 0.1 million |
| | | 0.5 A | 0.2 million |
| | 230 VAC | 1.0 A | 0.2 million |
| | | 0.5 A | 0.35 million |

Diagnostic Data of Fail-Safe Modules

A.1 Introduction

Introduction

This appendix describes the structure of diagnostic data in the system data. You need to know this structure if you want to evaluate diagnostic data of fail-safe modules in the standard user program.

Further Reading

The *System and Standard Functions* reference manual describes in detail the principles of evaluating diagnostic data of F-modules in the standard user program and describes the SFCs used for this.

A.2 Structure and Content of Diagnostic Data

Reading Out Diagnostics Data

Diagnostics reporting (errors and maintenance information) is made by OB 82. The additional alarm information can then be evaluated, for example, using SFB 54. SFB 54 "RALARM" reads alarm information from all modules with diagnostics capability - regardless of whether they are centrally plugged or used in PROFIBUS DP or PROFINET IO.

Note

SFB 54 in the *online help for STEP 7*

You can find detailed information on SFB 54 in the *online help for STEP 7*.

A variety of data records (read per SFC 59) and slave diagnostics (read per SFC 13) are also provided, which allow more detailed diagnostics.

Table A- 1 SFB/SFCs Reading Diagnostics Data

| SFB/SFC Number | Identifier | Application |
|----------------|------------|---|
| SFB 54 | RALARM | Reading additional alarm information of a DP slave / IO device or central I/O module in the relevant OB |
| SFC 59 | RD_REC | Reading data records of S7 diagnostics (saved to the data area of the standard user program) |
| SFC 13 | DPNRM_DG | Reading slave diagnostics data (saved to the data area of the standard user program) |

Position in the Diagnostic Message Frame of the Slave Diagnostics

When fail-safe modules are being used in the ET 200S and a diagnostic interrupt occurs, data records 0 and 1 are entered in the slave diagnostics of the ET 200S (= interrupt section).

The position of the interrupt section in the slave diagnostics data depends on the structure of the diagnostic message frame and on the length of the channel-specific diagnostics.

A detailed description of the structure of the diagnostic message frame and the position of the interrupt section in accordance with the PROFIBUS standard is available in the "Commissioning and Diagnostics" section of the *ET 200S Distributed I/O System* operating instructions.

Data Records 0 and 1 of the System Data (not for PROFINET IO)

The diagnostics data of a module can be up to 40 bytes long and is located in data records 0 and 1 of the system data area:

- Data record 0 contains 4 bytes of diagnostics data that describe the state of the F-module.
- Data record 1 contains
 - The 4 bytes of diagnostics data of the F-module that are also in data record 0 and
 - Up to 36 bytes of channel-specific diagnostics data, depending on the F-module (see "*Channel-Specific Diagnostics from Byte 8*").

Description

The next section describes the content and structure of the individual diagnostics data bytes.

General rule: If a fault occurs, the corresponding bit is set to "1".

Bytes 0 and 1

The figure below shows the contents of bytes 0 and 1 in the diagnostics data.

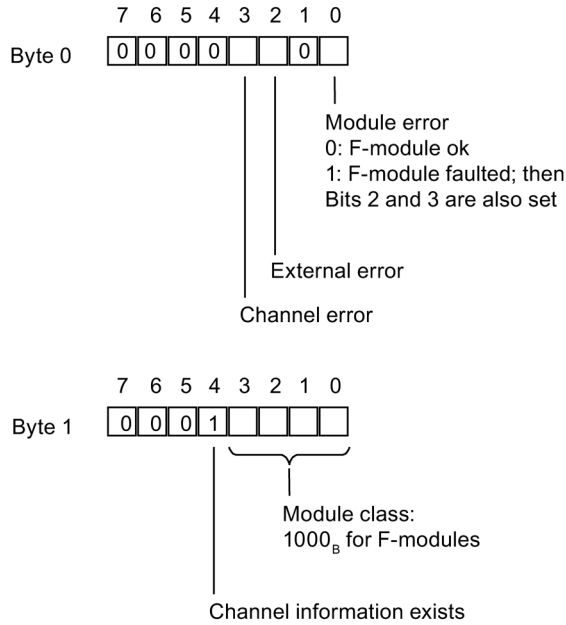

Figure A-1 Bytes 0 and 1 of Diagnostics Data

Bytes 2 and 3

The figure below shows the contents of bytes 2 and 3 in the diagnostics data.

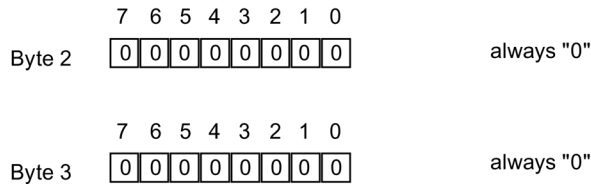

Figure A-2 Bytes 2 and 3 of Diagnostics Data

Bytes 4 to 6

The figure below shows the contents of bytes 4 to 6 in the diagnostics data.

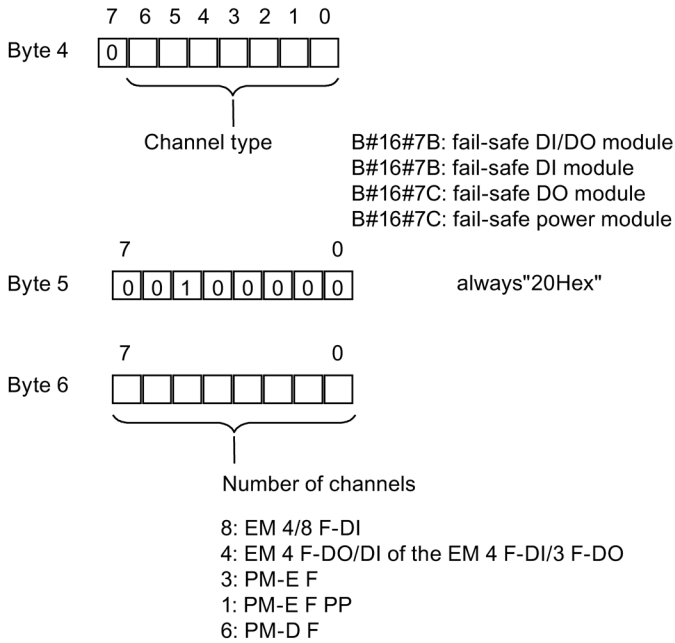

Figure A-3 Bytes 4 to 6 of Diagnostics Data

Byte 7 with EM 4/8 F-DI DC24V PROFIsafe

The figure below shows the content of Byte 7 of the diagnostics data for EM 4/8 F-DI DC24V PROFIsafe.

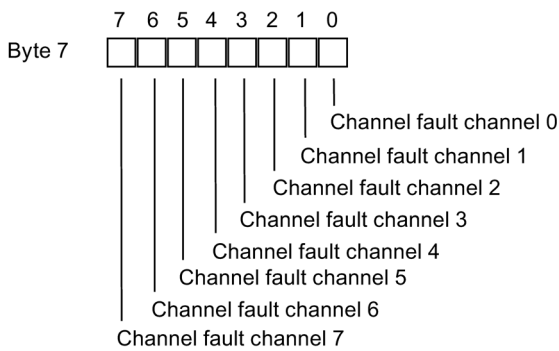

Figure A-4 Byte 7 of diagnostics data for EM 4/8 F-DI DC24V PROFIsafe

Byte 7 with EM 4 F-DI/3 F-DO DC24V PROFIsafe

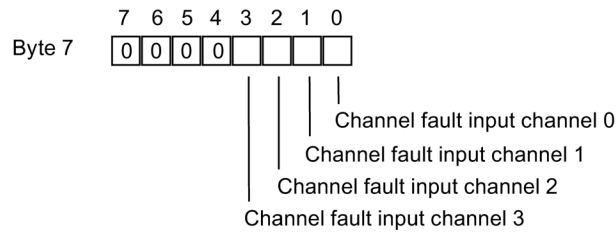

Figure A-5 Byte 7 of diagnostics data for EM 4 F-DI/3 F-DO DC24V PROFIsafe

Byte 7 with EM 4 F-DO DC24V/2A PROFIsafe

The figure below shows the content of Byte 7 of the diagnostics data for EM 4 F-DO DC24V/2A PROFIsafe.

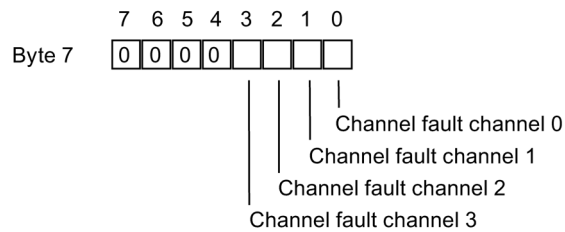

Figure A-6 Byte 7 of diagnostics data for EM 4 F-DO DC24V/2A PROFIsafe

Byte 7 with PM-E F pm DC24V PROFIsafe

The figure below shows the content of Byte 7 of the diagnostics data for the PM-E F pm DC24V PROFIsafe.

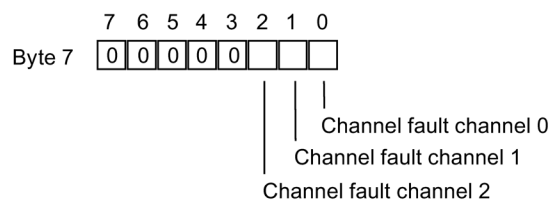

Figure A-7 Byte 7 of diagnostics data for PM-E F pm DC24V PROFIsafe

Byte 7 with PM-E F pp DC24V PROFIsafe

The figure below shows the content of Byte 7 of the diagnostics data for the PM-E F pp DC24V PROFIsafe

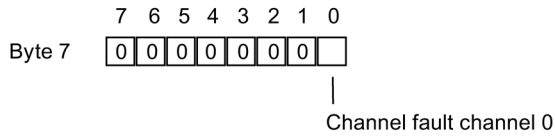

Figure A-8 Byte 7 of diagnostics data for PM-E F pp DC24V PROFIsafe

Byte 7 with PM-D F DC24V PROFIsafe

The figure below shows the content of Byte 7 of the diagnostics data for the PM-D F DC24V PROFIsafe.

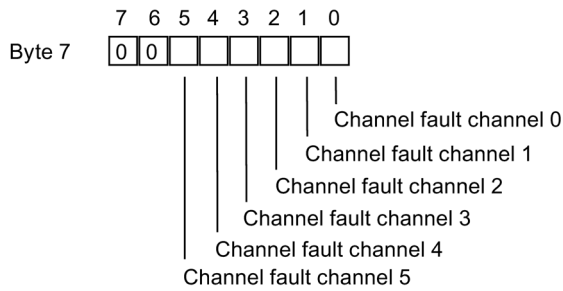

Figure A-9 Byte 7 of diagnostics data for PM-D F DC24V PROFIsafe

Channel-Specific Diagnostics from Byte 8

Channel-specific diagnostics start at byte 8 of the diagnostics data. Each channel is provided with 4 bytes of diagnostic information. The inputs apply to the EM 4 F-DI/3 F-DO.

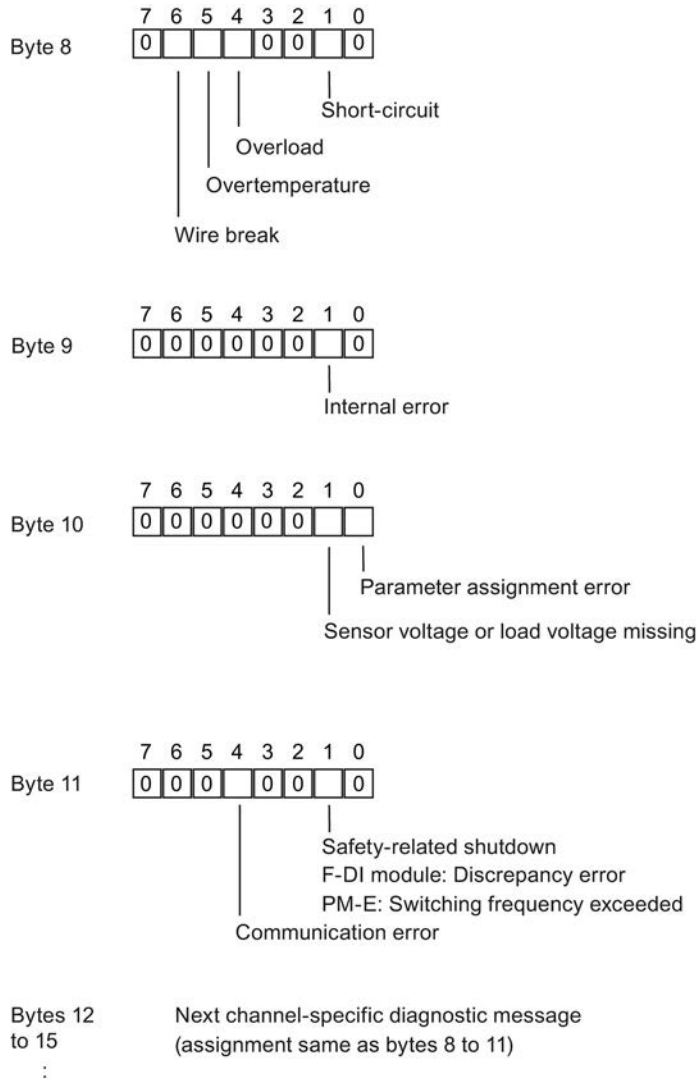

Figure A-10 Channel-Specific Diagnostics Starting at Byte 8 of the Diagnostics Data

Byte 27 on 4 F-DI/3 F-DO (Outputs)

The figure below shows the content of Byte 27 of the diagnostics data for the outputs of the 4 F-DI/3 F-DO.

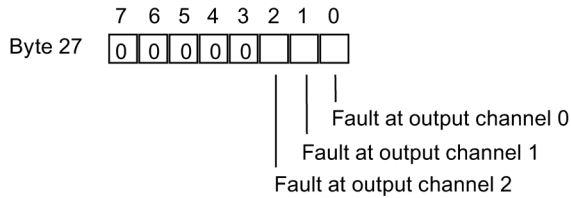

Figure A-11 Byte 27 of the diagnostics data for the outputs of the 4 F-DI/3 F-DO

Channel-Specific Diagnostics in Bytes 28 to 43

Channel-specific diagnostics start at byte 28 of the diagnostics data. Each channel is provided with 4 bytes of diagnostic information.

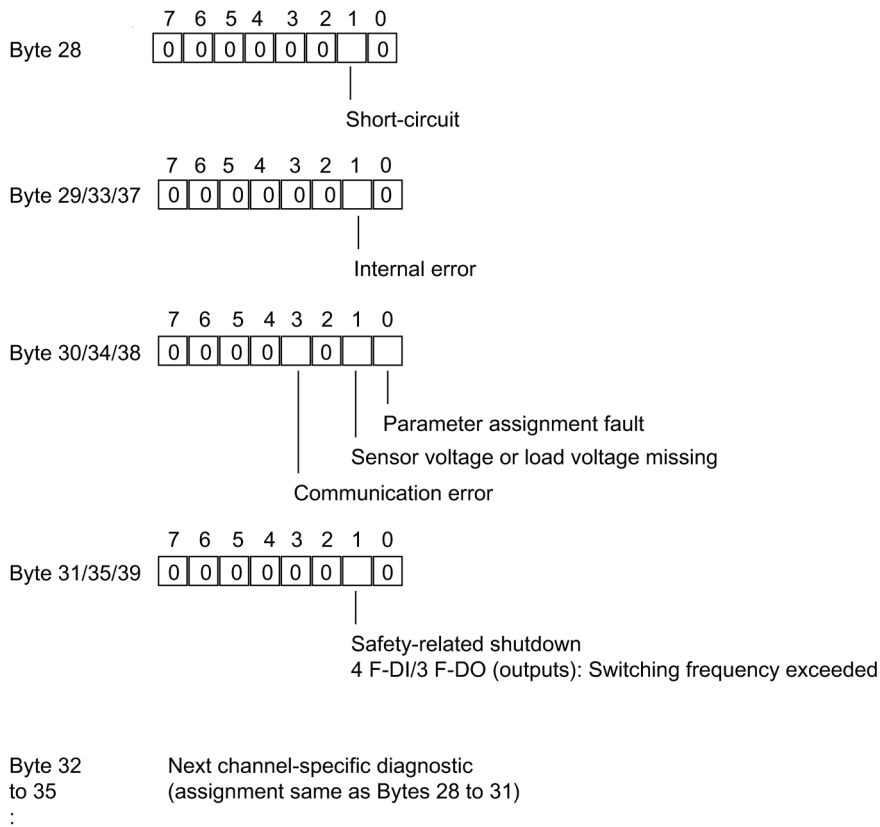

Figure A-12 Channel-Specific Diagnostics Starting at Byte 28 of the Diagnostics Data

Due to the different numbers of channels of the F-modules, data record 1 has differing lengths:

| | |
|-----------------------------------|----------|
| EM 4/8 F-DI DC24V PROFIsafe: | 40 bytes |
| EM 4 F-DO DC24V/2A PROFIsafe: | 24 bytes |
| EM 4 F-DI/3 F-DO DC24V PROFIsafe: | 36 bytes |
| PM-E F pm DC24V PROFIsafe: | 20 bytes |
| PM-E F pp DC24V PROFIsafe: | 12 bytes |
| PM-D F DC24V PROFIsafe: | 32 bytes |

Dimension Drawings

TM-x30x4x-xx Terminal Modules with Plugged Fail-safe Module

The following provides a dimension drawing for TM-x30x4x-xx terminal modules with plugged PM-E F pm, PM-E F pp, F-DI or F-DO module.

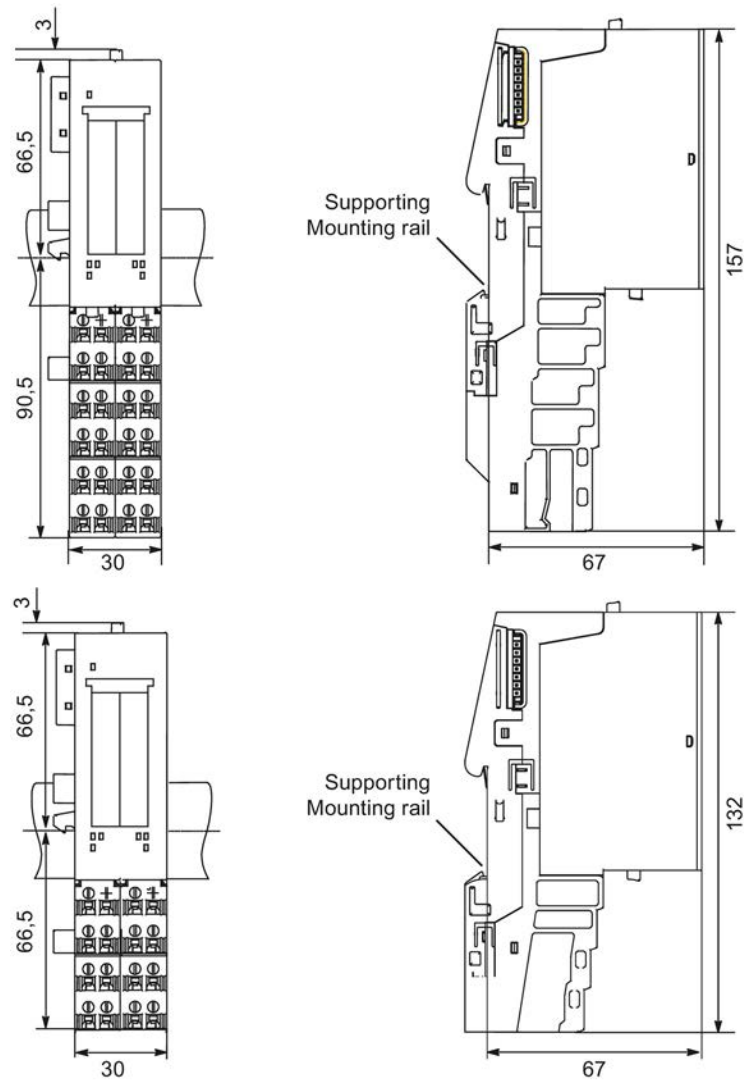

Figure B-1 Dimension Drawing of Terminal Modules with PM-E F pm, PM-E F pp, F-DI or F-DO module

TM-PF30S47-F1 Terminal Module with Plugged Fail-safe Module

The following is a dimension drawing for a TM-PF30S47-F1 terminal module with plugged PM-D F module.

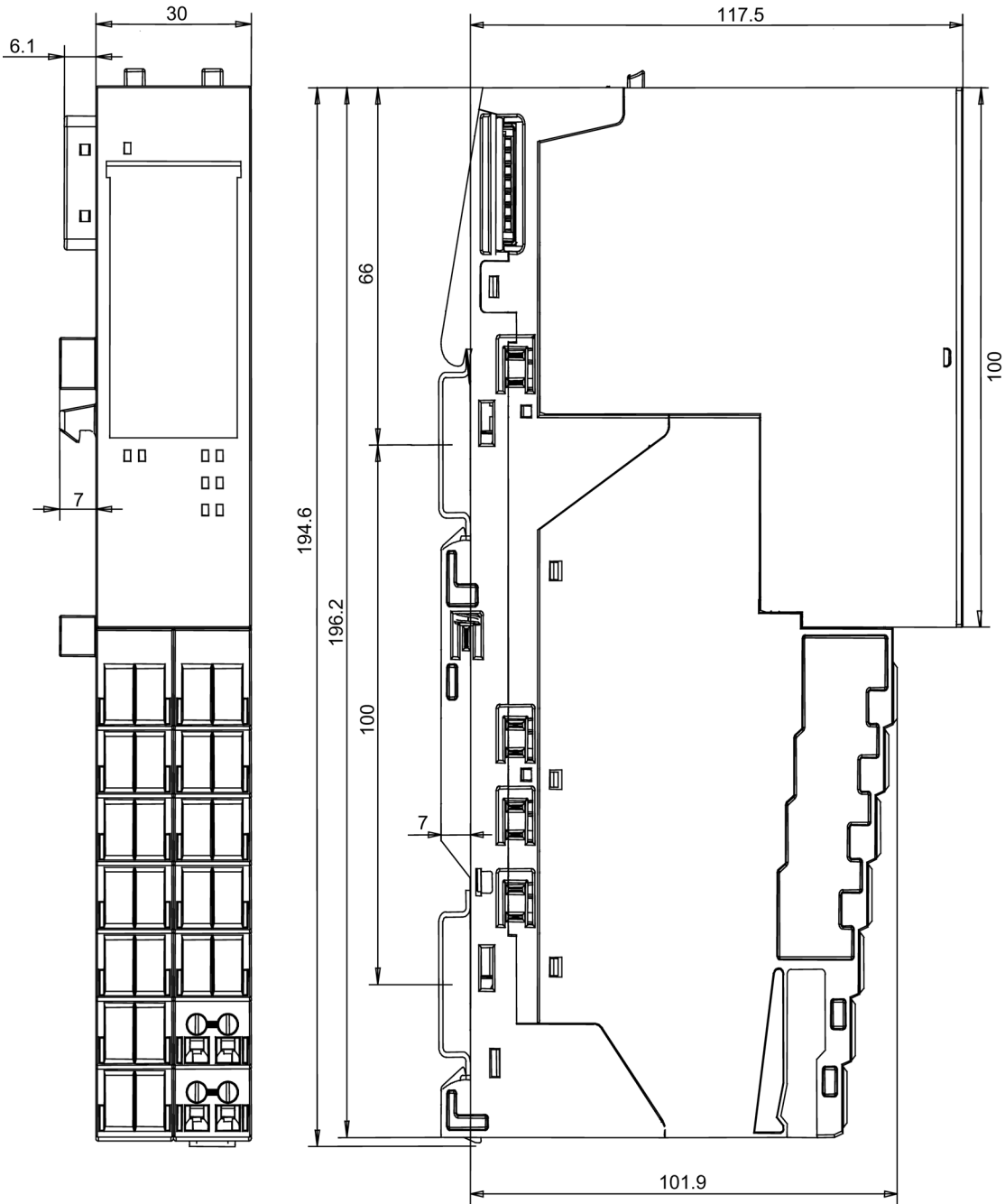

Figure B-2 Dimension drawing of terminal module with PM-D F DC24V PROFIsafe

Accessories and Order Numbers

Accessories and Order Numbers

The table below lists the order numbers of terminal modules, of fail-safe PMs and EMs, and of accessories which can be ordered for the fail-safe modules.

| Component | Order Number |
|--|--------------------|
| Terminal modules for F-DI and F-DO: | |
| TM-E30S44-01 (screw-in type), 1 item | 6ES7193-4CG20-0AA0 |
| TM-E30C44-01 (snap-on type), 1 item | 6ES7193-4CG30-0AA0 |
| TM-E30S46-A1 (screw-in type), 1 item | 6ES7193-4CF40-0AA0 |
| TM-E30C46-A1 (snap-on type), 1 item | 6ES7193-4CF50-0AA0 |
| Terminal modules for PM-E F pm DC24V PROFIsafe and PM-E F pp DC24V PROFIsafe: | |
| TM-P30S44-A0 (screw-in type), 1 item | 6ES7193-4CK20-0AA0 |
| TM-P30C44-A0 (snap-on type), 1 item | 6ES7193-4CK30-0AA0 |
| Terminal module for PM-D F DC24V PROFIsafe: | |
| TM-PF30S47-F1 (screw-in type), 1 item | 3RK1903-3AA00 |
| Fail-safe power modules: | |
| PM-E F pm DC24V PROFIsafe | 6ES7138-4CF03-0AB0 |
| PM-E F pp DC24V PROFIsafe | 6ES7138-4CF42-0AB0 |
| PM-D F DC24V PROFIsafe | 3RK1903-3BA02 |
| Fail-safe electronic module: | |
| 4/8 F-DI DC24V PROFIsafe | 6ES7138-4FA05-0AB0 |
| 4 F DI/3 DO DC24V PROFIsafe | 6ES7138-4FC01-0AB0 |
| 4 F-DO DC24V/2A PROFIsafe | 6ES7138-4FB04-0AB0 |
| 1 F-RO DC24V/AC24..230V/5A | 6ES7138-4FR00-0AA0 |
| Accessories: | |
| Label sheets DIN A4, yellow, quantity of 10 | 6ES7193-4BB00-0AA0 |

Response Times

Introduction

The response times of the ET 200S F-modules are listed below. The response time of F-modules is included in the calculation of the F-system response time.

Information about the calculation of F-system response times is available in the *Safety Engineering in SIMATIC S7* System Description.

Definition of Response Time

For fail-safe digital inputs: The response time defines the interval between a signal transition at the digital input and the reliable availability of the safety message frame on the backplane bus.

For fail-safe digital outputs: The response time defines the interval between the receipt of a safety message frame from the backplane bus and the signal transition at the digital output.

Maximum response time of the PM-E F pm DC24V PROFIsafe

The maximum response time of the PM-E F pm DC24V PROFIsafe (with or without fault) is equivalent to the maximum internal processing time T_{\max} .

The internal processing times of the electronic PM channel depend on the readback time parameter setting (see table below).

Table D- 1 PM-E F pm DC24V PROFIsafe: Internal processing times of the electronic PM channel

| PM-E F pm DC24V PROFIsafe (electronic PM channel) | | | |
|---|-----------------|---|---|
| Programmed Readback Time | Limit Frequency | Minimum Internal Processing Time T_{\min} | Maximum Internal Processing Time T_{\max} |
| 1 ms | 32.3 Hz | 4 ms | 16 ms |
| 5 ms | 28.6 Hz | 4 ms | 20 ms |
| 10 ms | 25.0 Hz | 4 ms | 25 ms |
| 50 ms | 12.5 Hz | 4 ms | 55 ms |
| 100 ms | 7.7 Hz | 4 ms | 90 ms |
| 200 ms | 4.3 Hz | 4 ms | 150 ms |
| 400 ms | 2.3 Hz | 4 ms | 300 ms |

Table D- 2 PM-E F pm DC24V PROFIsafe: Internal processing times of the P1/2 channel

| Measurement channel | Minimum Internal Processing Time T_{min} | Maximum Internal Processing Time T_{max} |
|---|--|--|
| PM-E F pm DC24V PROFIsafe (P1/2 channel; relay; switch on) | 4 ms | 10 ms |
| PM-E F pm DC24V PROFIsafe (P1/2 channel; relay; switch off) | 6 ms | 14 ms |

Maximum response time of the PM-E F pp DC24V PROFIsafe

The maximum response time of the PM-E F pp DC24V PROFIsafe (with or without fault) is equivalent to the maximum internal processing time T_{max} .

Table D- 3 PM-E F pp DC24V PROFIsafe: Internal processing times

| Measurement channel | minimum internal processing time T_{min} | maximum internal processing time T_{max} |
|---|--|--|
| PM-E F pp DC24V PROFIsafe (P1/2 channel; relay; switch on) | 4 ms | 10 ms |
| PM-E F pp DC24V PROFIsafe (P1/2 channel; relay; switch off) | 6 ms | 12 ms |

Maximum response time of the PM-D F DC24V PROFIsafe

The maximum response time of the PM-D F DC24V PROFIsafe (with or without fault) is equivalent to the maximum internal processing time T_{max} .

Table D- 4 PM-D F DC24V PROFIsafe: Internal processing times

| Measurement channel | Minimum Internal Processing Time T_{min} | Maximum Internal Processing Time T_{max} |
|--|--|--|
| PM-D F DC24V PROFIsafe (electronic PP channel) | 3 ms | 9 ms |

Maximum response time of the EM 4/8 F-DI DC24V PROFIsafe

Formula for calculating the maximum response time if there is no fault:

Maximum response time
without fault = T_{\max} + input delay + short-circuit test time*

*: Short-circuit test time = 2 x input delay

Program the input delay and short-circuit test in *STEP 7*.

Table D- 5 EM 4/8 F-DI DC24V PROFIsafe: Internal Processing Times

| Sensor evaluation | minimum internal processing time T_{\min} | maximum internal processing time T_{\max} |
|-------------------|---|---|
| 1oo1 and 1oo2 | 5 ms | 11 ms |

Maximum response time if a fault occurs:

The table below contains the maximum response times of the F-DI module when a fault occurs, depending on the parameter settings in *STEP 7* and on the sensor evaluation.

Table D- 6 EM 4/8 F-DI DC24V PROFIsafe: Maximum Response Time if a Fault Occurs

| | 1oo1 evaluation | | | 1oo2 evaluation** | | |
|--------------------------------|-----------------|-------|-------|-------------------|-------|-------|
| Input Delay | 0.5 ms | 3 ms | 15 ms | 0.5 ms | 3 ms | 15 ms |
| Short-circuit test deactivated | 18 ms | 20 ms | 32 ms | 12 ms | 14 ms | 26 ms |
| Short-circuit test activated | 29 ms | 40 ms | 91 ms | 13 ms | 20 ms | 56 ms |

: The response times with **1oo2 evaluation also depend on the configured discrepancy behavior:
Provide 0 value: The times defined in the table above apply.
Provide last valid value: The times in the table above are extended by the programmed discrepancy time.

Note

Please note that the Excel files for calculating the maximum response times (*s7fcotia.xls* and *s7ftimea.xls*) included with the *S7 Distributed Safety* and *S7 F/FH Systems* option packages already support calculation of the extension of the "Maximum response time in the event of a fault" by the programmed discrepancy time.

Maximum response time of the EM 4 F-DI/3 F-DO DC24V PROFIsafe

Formula for calculating the maximum response time if there is no fault:

Maximum response time
without a fault = T_{max} + input delay + short-circuit test time*

*: Short-circuit test time = 2 x input delay

Parameters for the input delay and the short-circuit test are assigned in *STEP 7*.

Table D- 7 EM 4 F-DI/3 F-DO DC24V PROFIsafe: Internal Processing Times

| Sensor Evaluation | minimum internal processing time T_{min} | maximum internal processing time T_{max} |
|-------------------|--|--|
| 1oo2 | 4 ms | 9 ms |

Maximum response time if a fault occurs:

The table below contains the maximum response times of the F-DI/F-DO module when a fault occurs, depending on the parameter settings in *STEP 7* and on the sensor evaluation.

Table D- 8 EM 4 F-DI/3 F-DO DC24V PROFIsafe: Maximum Response Time if a Fault Occurs

| 1oo2 evaluation* | |
|--|-------------|
| Input Delay | 3 ms |
| Short-circuit test deactivated | 14 ms |
| Short-circuit test activated | 22 ms |
| *: The response times with 1oo2 evaluation also depend on the configured discrepancy behavior: Provide 0 value: The times defined in the table above apply. Provide last valid value: The times in the table above are extended by the programmed discrepancy time. | |

Note

Please note that the Excel files for calculating the maximum response times (*s7fcotia.xls* and *s7ftimea.xls*) included with the *S7 Distributed Safety* and *S7 F/FH Systems* option packages already support calculation of the extension of the "Maximum response time in the event of a fault" by the programmed discrepancy time.

Maximum response time of outputs:

The maximum response time of the EM 4 F-DI/3 F-DO DC24V PROFIsafe (with or without fault) is equivalent to the maximum internal processing time T_{max} .

The internal processing times of the electronic PM channel depend on the readback time parameter setting (see table below).

Table D- 9 EM 4 F-DI/3 F-DO DC24V PROFIsafe: Internal Processing Times

| EM 4 F-DI/3 F-DO DC24V PROFIsafe (electronic PM channel) | | | |
|---|------------------------|--|--|
| Programmed Readback Time | Limit Frequency | Minimum Internal Processing Time T_{min} | Maximum Internal Processing Time T_{max} |
| 1 ms | 37.0 Hz | 4 ms | 13 ms |
| 5 ms | 32.2 Hz | 4 ms | 14 ms |
| 10 ms | 27.7 Hz | 4 ms | 20 ms |
| 50 ms | 13.2 Hz | 4 ms | 32 ms |
| 100 ms | 7.9 Hz | 4 ms | 50 ms |
| 200 ms | 4.4 Hz | 4 ms | 75 ms |
| 400 ms | 2.3 Hz | 4 ms | 140 ms |

Maximum response time of the EM 4 F-DO DC24V/2A PROFIsafe

The maximum response time of the EM 4 F-DO DC24V/2A PROFIsafe (with or without fault) is equivalent to the maximum internal processing time T_{max} .

The internal processing times of the electronic PM channel depend on the readback time parameter setting (see table below).

Table D- 10 EM 4 F-DO DC24V/2A PROFIsafe: Internal Processing Times

| EM 4 F-DO DC24V/2A PROFIsafe (electronic PM channel) | | | |
|---|------------------------|--|--|
| Programmed Readback Time | Limit Frequency | Minimum Internal Processing Time T_{min} | Maximum Internal Processing Time T_{max} |
| 1 ms | 32.3 Hz | 4 ms | 16 ms |
| 5 ms | 28.6 Hz | 4 ms | 20 ms |
| 10 ms | 25.0 Hz | 4 ms | 25 ms |
| 50 ms | 12.5 Hz | 4 ms | 55 ms |
| 100 ms | 7.7 Hz | 4 ms | 100 ms |
| 200 ms | 4.3 Hz | 4 ms | 150 ms |
| 400 ms | 2.3 Hz | 4 ms | 300 ms |

Maximum response time of the EM 1 F-RO DC24V/AC24..230V/5A

The maximum response time of the EM 1 F-RO DC24V/AC24..230V/5A (with or without fault) is equivalent to the total of:

- the maximum response time of the fail-safe output used to activate the F-RO module
- plus the relay switching or release time of the F-RO module

See also

Properties of the 4/8 F-DI DC24V PROFIsafe Digital Electronic Module (Page 122)

Connecting Loads

E.1 Connecting capacitive loads

Connecting capacitive loads on PM-E F pm DC24V PROFIsafe, EM 4 F-DO DC24V/2A PROFIsafe

If the electronic outputs of the PM-E F pm DC24V PROFIsafe, of EM 4 F-DO DC24V/2A are connected to low-power loads that have capacitance, this can lead to generation of a "short-circuit" error message. Reason: The capacitance cannot be sufficiently discharged during the programmed self-test readback time.

The figure below shows the typical curves of the parameterized readback times indicating the relationship between load resistance and connectable load capacitance.

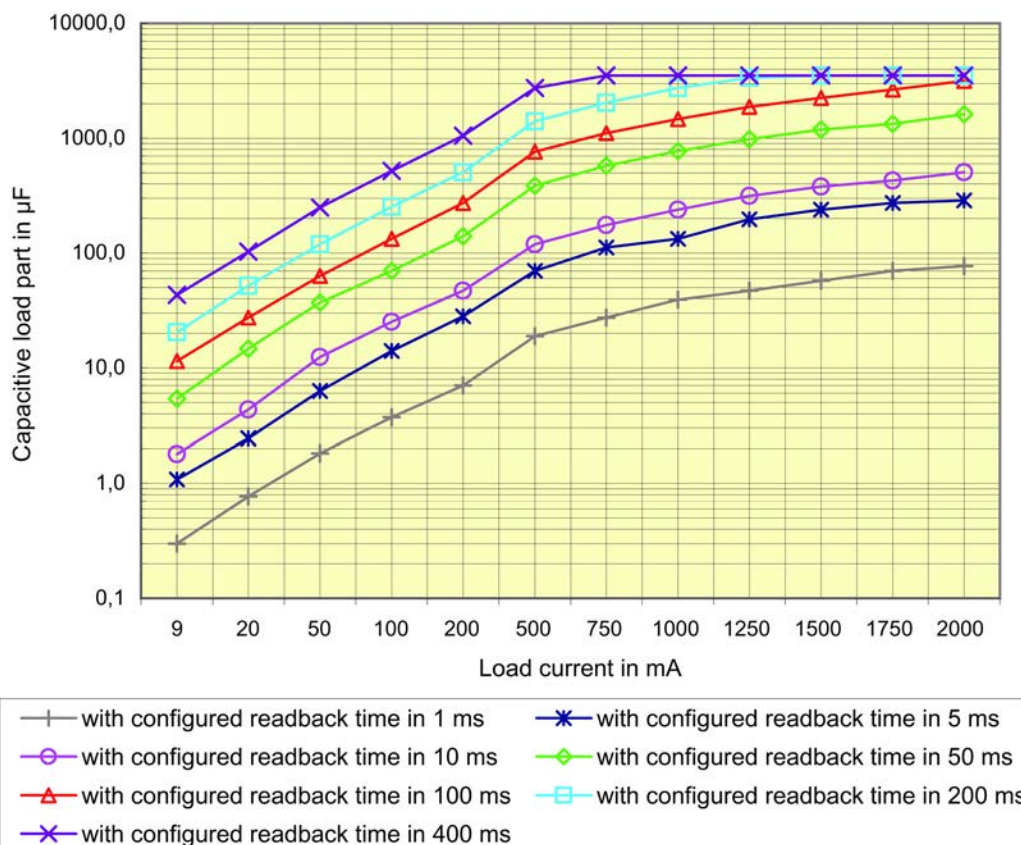

Remedy:

1. Determine the load current and capacitance of the load.
2. Locate the operating point in the diagram above.
3. If the operating point is above the curve, you must increase the load current until the new operating point is below the curve by connecting a resistor in parallel.

Connecting Capacitive Loads at the EM 4 F-DI/3 F-DO DC24V PROFIsafe

The figure below shows the typical curves of the parameterized readback times indicating the relationship between load resistance and connectable load capacitance.

Behavior is as described above.

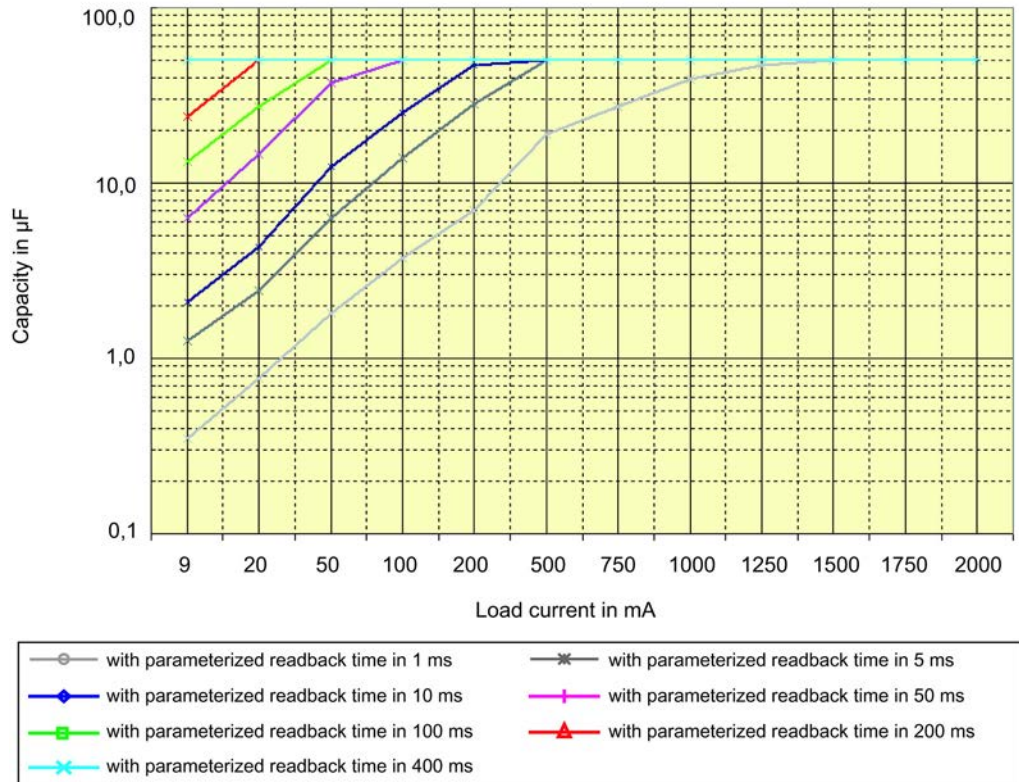

E.2 Connecting inductive loads

Connecting inductive loads on PM-E F pm DC24V PROFIsafe, EM 4 F-DO DC24V/2A PROFIsafe and EM 4 F-DI/3 F-DO DC24V PROFIsafe

The diagram below shows the maximum permitted inductive loads as a function of the load current and switching frequency.

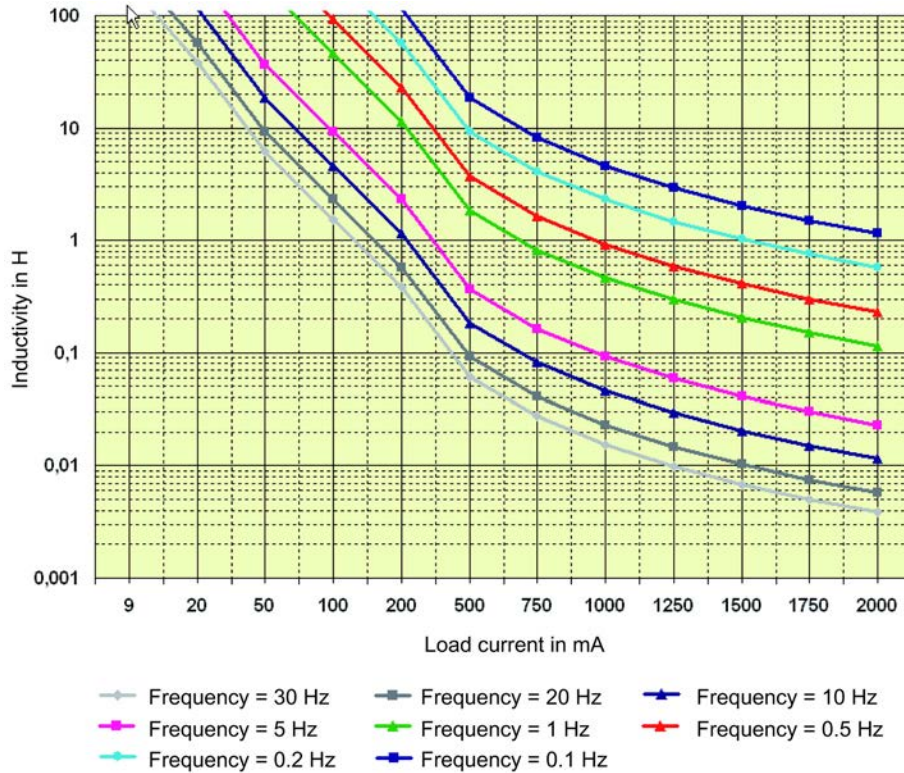

Glossary

1oo1 evaluation

-> 1oo1 evaluation

Type of -> sensor evaluation – with the 1oo1 evaluation -> sensor is non-redundant and connected to the F-module via one channel.

1oo1 evaluation

-> 1oo1 evaluation

Type of -> sensor evaluation – with the 1oo1 evaluation -> sensor is non-redundant and connected to the F-module via one channel.

1oo2 evaluation

Type of -> sensor evaluation - 1oo2 evaluation covers two input channels which are interconnected either with a single dual-channel sensor, or with two single-channel sensors. The input signals are compared internally for equivalence or nonequivalence.

2oo2 evaluation

-> 1oo2 evaluation

Acknowledgment time

The -> F-I/O acknowledges the sign of life specified by the -> F-CPU within the acknowledgment time. The acknowledgment time is included in the calculation of the overall > monitoring time and -> response time for the F-system.

Actuator

Actuators can be power relays or contactors for switching on loads, or they can be loads themselves (e.g. directly controlled solenoid valves).

AUX1 bus

Power modules allow the additional connection of a voltage (24 VDC) which you can wire via the AUX(iliary) bus. AUX(iliary) buses can be used individually as a protective conductor bus or to supply additionally-required voltage.

Availability

Availability is the probability that a system is functional at a specific point in time. Availability can be enhanced by redundancy, for example by using multiple -> sensors at the same measuring point.

Backplane bus

The backplane bus is a serial data bus via which the IM 151 interface module communicates with the electronic modules/motor starters, supplying them with the required voltage. The modules are interconnected by way of terminal modules.

Category

Category in accordance with ISO 13849-1:2006 or EN ISO 13849-1:2008

-> Fail-safe modules can be used in safety mode up to Category 4.

Channel error

Channel-specific fault, such as a wire break or short circuit.

In channel-specific passivation, the affected channel is either automatically reintegrated or the F-module must be removed and reinserted after the fault has been eliminated.

Channel group

The channels of a module are grouped together in a channel group. Certain parameters in *STEP 7* can only be assigned to channel groups and not to individual channels.

Channel number

Channel numbers are used to uniquely identify the inputs and outputs of a module and to assign channel-specific diagnostic messages.

Channel-specific passivation

With this type of passivation, only the affected channel is passivated when a -> channel fault occurs. All channels of the -> fail-safe module are passivated when a -> module fault is detected.

Configuring

A configuration denotes the systematic arrangement of the individual ET 200S modules (set-up).

CRC

Cyclic Redundancy Check -> CRC signature

CRC signature

The validity of the process values in the safety message frame, the accuracy of the assigned address references, and the safety-related parameters are validated by means of the CRC signature in the safety message frame.

Dark period

Dark periods occur during shutdown tests and complete bit pattern tests. The fail-safe output module switches test-related zero signals to the active output. This output is then briefly disabled (= dark period). An -> actuator with sufficient lag does not respond to these signals and remains switched on.

Discrepancy analysis

The discrepancy analysis for equality/non-equality is used at fail-safe inputs to detect errors based on the timing of two signals with the same functionality. Discrepancy analysis is initiated when different levels (when testing for nonequivalence: same voltage levels) are detected at two associated input signals. The signals are checked to determine whether the difference (when checking for nonequivalence: the consistency) has disappeared within a programmable period known as the -> discrepancy time. If not, this means that a discrepancy error exists.

The discrepancy analysis compares the two input signals of the 1oo2 sensor evaluation in the fail-safe input module.

Discrepancy time

Configured time for the -> discrepancy analysis. If the discrepancy time is set too high, the times for fault detection and -> fault reaction are extended unnecessarily. If the discrepancy time is set too low, availability is decreased unnecessarily since a discrepancy error is detected when, in reality, no error exists.

DP master

A master which operates in compliance with the standard IEC 61784-1 Ed3 CP 3/1.

DP slave

A slave which operates on PROFIBUS based on the PROFIBUS DP protocol in compliance with the standard IEC 61784-1 Ed3 CP 3/1.

F monitoring time

-> PROFIsafe monitoring time

Fail-safe modules

These are ET 200S modules that can be used for safety-related operation (-> safety mode) in the ET 200S distributed I/O system. These modules are equipped with integrated -> safety functions.

Fail-safe systems

Fail-safe systems (F-systems) remain in a safe state or immediately assume another safe state as soon as particular failures occur.

Fault response time

The maximum fault response time of an F-system defines the interval between the occurrence of any fault and a safe reaction at all affected fail-safe outputs.

For -> F-systems in general: The maximum fault response time defines the interval between the occurrence of any fault at any -> F-I/O and the safe reaction at the corresponding fail-safe output.

For digital inputs: The maximum fault response time defines the interval between the occurrence of the fault and the safe reaction at the backplane bus.

For digital outputs: The maximum fault response time defines the interval between the occurrence of the fault and the safe reaction at the digital output.

Fault tolerance time

The fault tolerance time of a process is the time a process can be left unattended without risk to life and limb of the operating personnel, or damage to the environment.

Within the fault tolerance time, the F-system can initiate any process control actions, i.e. it can control its process incorrectly or even not at all. The fault tolerance time depends on the type of process and must be determined on a case-by-case basis.

F-CPU

An F-CPU is a central processing unit with fail-safe capability which is approved for use in S7 Distributed Safety/S7 F/FH systems.

For S7 F/FH Systems, the F-copy license allows the central processing unit to be used as an F-CPU. In other words, it can execute a -> safety program.

An F-copy license is not required for S7 Distributed Safety. The F-CPU can also execute a -> standard user program.

F-I/O

Group designation for fail-safe inputs and outputs available in *SIMATIC S7* for the integration in the S7 Distributed Safety and S7 F/FH Systems fail-safe systems. They behave in accordance with the standards IEC 61784-1 Ed3 CP 3/1 or IEC 61784-2 CP 3/5 and CP 3/6 and IEC 61158 Types 5-10 and 6-10 and the PROFIsafe bus profile according to IEC 61784-3-3 Ed2. Available F-I/O modules:

- Fail-safe I/O module for ET 200eco
- S7-300 fail-safe signal modules (F-SMs)
- Fail-safe modules for ET 200S
- Fail-safe DP standard slaves (for S7 Distributed Safety only)
- fail-safe PA field devices
- fail-safe IO devices

F-Systems

-> Fail-safe systems

Interconnecting

Refers to the opening of a new voltage group by a power module.

This allows individual grouping of sensor and load supplies.

IO controller

-> PROFINET IO controller

IO device

-> PROFINET IO device

Module fault

Module faults can be external faults (e.g. missing load voltage) or internal faults (e.g. processor failure). Internal faults always require module replacement.

Monitoring time

-> PROFIsafe monitoring time

Motor starter (MS)

Motor starter is a generic term for direct and reversing starters. Motor starters are used to determine motor startup and the direction of rotation.

M-switch

Each fail-safe digital output of the ET 200S F-modules consists of a P-switch DOx P and an M-switch DOx M. The load is connected between the P and M-switches. To ensure voltage is applied to the load, both switches are always activated.

Nonequivalent sensor

An exclusive OR -> sensor is a changeover switch that is wired in -> fail-safe systems (dual-channel connection) to two inputs of a -> fail-safe I/O (for -> 1oo2 evaluation of sensor signals).

Parameter assignment

Assigning parameters with PROFIBUS DP: Transfer of slave parameters from the DP master to the DP slave

Assigning parameters to modules/submodules: Sets the behavior of modules/submodules with the *STEP 7* configuration software

Passivation

If an -> F-I/O detects a fault, it switches either the affected channel or all channels to a -> safe state; i.e. the channels of this F-I/O are passivated. The F-I/O reports the detected fault to the -> F-CPU.

When passivating channels at F-I/O with inputs, the -> F-system returns fail-safe values instead of the process values pending at the fail-safe inputs to the -> safety program.

When passivating channels at F-I/O with outputs, the F-system returns fail-safe values (0) to the fail-safe outputs instead of the output values provided by the safety program.

PD

PProgramming ddevice (PD): Personal computer in special compact industrial design. A PD is fully equipped for programming SIMATIC automation systems.

Performance Level

Performance Level (PL) to ISO 13849

Potential group

A group of electronic modules supplied by the same power module.

Prewiring

Denotes the wiring of terminal modules prior to insertion of the electronic modules.

Process image

The process image is part of the system memory of the CPU. At the start of cyclic program execution, the signal states of the inputs are transferred to the process image of the inputs. At the end of the cyclic program, the process output image is transferred to the outputs as the signal state.

PROFIBUS

PROcess **F**ield **B**US, process and fieldbus standard specified in IEC 61784-1 Ed3 CP 3/1. This standard specifies the functional, electrical and mechanical properties of a bit-serial fieldbus system.

PROFIBUS is available with the protocols DP (= distributed periphery) and PA (= process automation).

PROFINET IO

PROFINET IO is the PROFINET communication concept for implementing modular, distributed applications.

PROFINET IO enables creation of automation solutions using the familiar, proven methods of PROFIBUS.

PROFINET IO implementation is based on both the PROFINET standard for automation devices and the *STEP 7* engineering tool.

This means that you have the same application view in *STEP 7*, regardless of whether you are configuring PROFINET or PROFIBUS devices. Creation of your user program is similar for PROFINET IO and PROFIBUS DP, provided you use the expanded blocks and system status lists for PROFINET IO.

PROFINET IO controller

Device via which connected IO devices are addressed. That is, the IO controller exchanges input and output signals with assigned field devices. The IO controller is often the controller in which the automation program runs.

PROFINET IO device

A PROFINET IO device is a decentralized field device that is assigned to one of the IO controllers (e.g. remote IO, valve terminals, frequency converters, switches)

PROFINET IO supervisor

Programming device (PD), PC or HMI device used for commissioning and diagnostics.

PROFINET IO controller with assigned PROFINET IO devices.

PROFIsafe

Safety-related PROFIBUS DP/PA and PROFINET IO bus profile according to IEC 61784-3-3 Ed2 for communication between the -> safety program and the -> F-I/O in an -> F-System.

PROFIsafe address

Each -> fail-safe module is assigned a separate PROFIsafe address. The PROFIsafe address must be configured in *STEP 7 HW Config* and set via a switch on the fail-safe I/O.

PROFIsafe monitoring time

Monitoring time for safety-related communication between the F-CPU and F-I/O.

Proof-test interval

Period after which a component must be forced to fail-safe state, that is, it is either replaced with an unused component, or is proven faultless.

P-switch

-> M-switch

Redundancy, availability-enhancing

Multiple instances of components with the objective of maintaining component functionality in the event of hardware faults.

Redundancy, safety-enhancing

Multiple installations of components with the goal of reducing hardware faults; for example, -> 1oo2 evaluation in -> fail-safe modules.

Reintegration

The -> F-I/O must be reintegrated (depassivated) after a fault has been cleared. Reintegration (switchover from fail-safe values to process values) occurs either automatically or only after a user acknowledgment in the safety program.

For an F-I/O module with inputs, the process values pending at the fail-safe inputs are again made available to the -> safety program following reintegration. For an F-I/O module with outputs, the output values provided by the -> safety program are again made available to the fail-safe outputs following reintegration.

Response time

The response time starts with the detection of an input signal and ends with the modification of a logically linked output signal.

The actual response time is between the shortest and the longest response time. The longest response time must always be anticipated when configuring a plant.

For fail-safe digital inputs: The response time defines the interval between a signal transition at the digital input and the reliable availability of the -> safety message frame on the backplane bus.

For fail-safe digital outputs: The response time defines the interval between the receipt of a safety message frame from the backplane bus and the signal transition at the digital output.

Reversing starter

A -> motor starter which determines the rotational direction of a motor. Consists of a circuit-breaker and two contactors.

Safe state

The basic principle of the safety concept in F-systems is the existence of a safe state for all process variables. For the digital F-I/O, for example, the safe state is the value "0".

Safety class

Safety Integrity Level (SIL) according to IEC 61508:2000. The higher the Safety Integrity Level, the more rigid the measures for prevention of systematic faults and for management of systematic faults and hardware failures.

The fail-safe modules support operation in safety mode up to safety class SIL3.

Safety function

The safety function is a mechanism built into the -> F-CPU and -> F-I/O that allows them to be used in -> S7 Distributed Safety or S7 F/FH fail-safe systems.

In accordance with IEC 61508:2000: A safety function is implemented by a safety system in order to maintain or force a system safe state in the event of a specific fault.

Safety message frame

In safety mode, data are transferred between the -> F-CPU and the -> F-I/O in a safety message frame.

Safety mode

Operating mode of the -> F-I/O which allows -> safety-related communication by means of -> safety message frames.

ET 200S -> fail-safe modules can only be operated in safety mode.

Safety program

Safety-related user program.

Safety-related communication

Type of communication for the exchange of fail-safe data.

Sensor evaluation

There are two types of sensor evaluation:

-> 1oo1 evaluation – sensor signal is read once

-> 1oo2 evaluation – sensor signal is read in twice from the same F-module and compared internally

Sensors

Sensors are used for accurate detection of digital and analog signals as well as routes, positions, velocities, rotational speeds, masses, etc.

SIL

Safety Integrity Level -> safety class

Standard mode

Operating mode of the F-I/O which supports standard communication, but not -> safety-related communication by means of -> safety message frames.

Fail-safe signal modules of the S7-300 can be operated in standard mode or in -> safety mode. Fail-safe ET 200S modules are designed for operation in safety mode only.

Static parameters

Static parameters can only be set when the CPU is in STOP mode, and cannot be changed while the user program is running by means of SFC (system function).

Terminal module

The ET 200S distributed I/O system is terminated with the terminal module. An ET 200S cannot be operated without a terminal module.

Voltage bus (P1/P2)

Two internal buses (P1 and P2) supply the electronic modules with voltage. The voltage buses are fed by the power module and are connected via terminal modules.

Index

1

- 1oo1 evaluation
 - EM 4/8 F-DI DC24V PROFIsafe, 133
- 1oo2 evaluation
 - EM 4 F-DI/3 F-DO DC24V PROFIsafe, 171, 174
 - EM 4/8 F-DI DC24V PROFIsafe, 139, 141, 143, 145, 146, 147
- 1VsF LED, 56
 - EM 4/8 F-DI DC24V PROFIsafe, 149

2

- 2VsF LED, 56
 - EM 4/8 F-DI DC24V PROFIsafe, 149

A

- Accessories
 - Order numbers, 229
- Acknowledgment time
 - EM 4 F-DO DC24V/2A PROFIsafe, 202
 - EM 4/8 F-DI DC24V PROFIsafe, 155
 - PM-E F 24 VDC PROFIsafe, 121
 - PM-E F pm DC24V PROFIsafe, 97
 - PM-E F pp DC24V PROFIsafe, 111
- Actuators
 - external power supply, 45
 - Requirements, 50
 - with sufficient lag, 51
- Additional potential
 - Connecting, 25
- Address
 - PROFIsafe, 41
- Address assignment
 - PROFIsafe, 41
- Address Assignment
 - F-modules in the F-CPU, 39
 - Useful data in F-CPU, 39
- Address switch
 - for PROFIsafe addresses, 41
 - setting, 42
- Applications
 - EM 4/8 F-DI DC24V PROFIsafe, 131
- Approval
 - CE, 61

- CSA, 62
- cULus, 62, 63
- FM, 63
- Shipbuilding, 64
- UL, 62
- Assignable diagnostics
 - Functions, 56
- Assignment
 - Fail-safe inputs, 135, 144, 167
- Automation system
 - fail-safe, 15
- AUX 1 bus, 25

B

- Basic knowledge, required, 3
- Behavior at discrepancy, 128
 - EM 4/8 F-DI DC24V PROFIsafe, 126
- Behavior of discrepancy
 - EM 4 F-DI/3 F-DO DC24V PROFIsafe, 163
- Bit pattern test, 76
 - EM 4 F-DO DC24V/2A PROFIsafe, 196
 - PM-E F pm DC24V PROFIsafe, 90
- Block diagram
 - EM 4 F-DI/3 F-DO DC24V PROFIsafe, 162
 - EM 4/8 F-DI DC24V PROFIsafe, 125
- Block Diagram
 - EM 1 F-RO DC24V/AC24..230V/5A PROFIsafe, 208
 - EM 4 F-DO DC24V/2A PROFIsafe, 191
 - PM-D F DC24V PROFIsafe, 117
 - PM-E F pm DC24V PROFIsafe, 84
 - PM-E F pp DC24V PROFIsafe, 104

C

- cables
 - shielded, 127
- Capacitive crosstalk
 - Input signals, 81
 - Output signals, 81
- capacitive loads
 - switching, 90
- Capacitive loads
 - switching, 166, 195
- Category (Cat.)
 - achievable, 19

- Causes of faults
 - EM 4 F-DI/3 F-DO DC24V PROFIsafe, 180
 - EM 4 F-DO DC24V/2A PROFIsafe, 197
 - EM 4/8 F-DI DC24V PROFIsafe, 150
 - PM-D F DC24V PROFIsafe, 119
 - PM-E F pm DC24V PROFIsafe, 92
 - PM-E F pp DC24V PROFIsafe, 108
 - CE approval, 61
 - Changes
 - in this manual, 3
 - Channel
 - deactivated, 53
 - Channel error, 54
 - Channel group fault, 53
 - Channel-specific diagnostics
 - from byte 8 in diagnostics data, 223
 - of F-modules, 57
 - Climatic conditions
 - permitted, 72
 - Commissioning
 - the ET 200S, 21
 - Communication error, 48, 58
 - EM 4 F-DI/3 F-DO DC24V PROFIsafe, 179
 - EM 4 F-DO DC24V/2A PROFIsafe, 196
 - EM 4/8 F-DI DC24V PROFIsafe, 149
 - PM-D F DC24V PROFIsafe, 118
 - PM-E F pm DC24V PROFIsafe, 91
 - PM-E F pp DC24V PROFIsafe, 107
 - Reaction of the F-DI module, 55
 - Conditions
 - for safety class with EM 4 F-DI/3 F-DO DC24V PROFIsafe, 158
 - for safety class with EM 4 F-DO DC24V/2A PROFIsafe, 186
 - for safety class with EM 4/8 F-DI DC24V PROFIsafe, 122
 - For safety class with EM 4/8 F-DI DC24V PROFIsafe, 132
 - for safety classes with PM-D F DC24V PROFIsafe, 114
 - of use, 70
 - Shipping and storage of F-modules, 70
 - Conditions of use, 70
 - Configuration
 - ET 200S with fail-safe modules, 23
 - ET 200S with fail-safe motor starters, 24
 - Configuration example
 - Potential group, 23
 - with fail-safe motor starters,
 - Configuration rules
 - Fail-safe potential groups, 24
 - Configuring
 - F-modules, 30
 - Connecting
 - two relays on one digital output, 86
 - Connecting capacitive loads, 90, 166, 195
 - Connecting potentials
 - additional, 25
 - Conventions
 - in this manual, 6
 - Corrective measures
 - EM 4 F-DO DC24V/2A PROFIsafe, 197
 - EM 4/8 F-DI DC24V PROFIsafe, 150
 - PM-D F DC24V PROFIsafe, 119
 - Corrective Measures
 - EM 4 F-DI/3 F-DO DC24V PROFIsafe, 180
 - PM-E F pm DC24V PROFIsafe, 92
 - PM-E F pp DC24V PROFIsafe, 108
 - Cross circuit
 - EM 4 F-DO DC24V/2A PROFIsafe, 193
 - PM-E F pm DC24V PROFIsafe, 86
 - CSA approval, 62
 - cULus approval, 62, 63
 - Current carrying capacity
 - maximum, 30
- ## D
- Dark period
 - for actuators, 51
 - Deactivated channel, 53
 - Determining the parameter length
 - F-modules, 29
 - Determining the parameter length, 29
 - Diagnostic functions, 55
 - EM 4 F-DI/3 F-DO DC24V PROFIsafe, 179
 - EM 4 F-DO DC24V/2A PROFIsafe, 196
 - EM 4/8 F-DI DC24V PROFIsafe, 149
 - non-programmable, 55
 - PM-D F DC24V PROFIsafe, 118, 118
 - PM-E F pm DC24V PROFIsafe, 91
 - PM-E F pp DC24V PROFIsafe, 107
 - programmable, 56
 - Reading out, 59
 - Diagnostics
 - at the slave, 56
 - by LED display, 56
 - Channel-specific, 57
 - Purpose, 55
 - Diagnostics buffer
 - EM 4 F-DO DC24V/2A PROFIsafe, 197
 - EM 4/8 F-DI DC24V PROFIsafe, 150
 - Diagnostics data
 - Byte 7 for PM-D F DC24V PROFIsafe, 222

- Byte 7 on EM 4 F-DI/3 F-DO DC24V PROFIsafe, 221
 - Byte 7 on EM 4 F-DO DC24V/2A PROFIsafe, 221
 - Byte 7 on EM 4/8 F-DI DC24V PROFIsafe, 220
 - Byte 7 on PM-E F pm DC24V PROFIsafe, 221
 - Byte 7 on PM-E F pp DC24V PROFIsafe, 222
 - Bytes 0 and 1, 219
 - Bytes 2 and 3, 219
 - Bytes 4 to 6, 220
 - Position in the message frame, 218
 - Reading Out, 217
 - Structure and content, 218
 - Digital I/O module
 - fail-safe, 16
 - Digital output
 - Connecting to two relays, 86
 - Dimension drawings
 - F-modules, 227
 - Directives, 65
 - Discrepancy analysis, 129, 165
 - Discrepancy error
 - EM 4 F-DI/3 F-DO DC24V PROFIsafe, 179
 - EM 4/8 F-DI DC24V PROFIsafe, 149
 - Discrepancy time, 129, 165
 - EM 4 F-DI/3 F-DO DC24V PROFIsafe, 163
 - EM 4/8 F-DI DC24V PROFIsafe, 126
 - Disposal, 6
 - Distributed I/O system
 - Definition, 15
 - Documentation, additional, 5
 - Duration of sensor signals
 - Requirements, 50
- E**
- Electrical connection, 45
 - Electromagnetic Compatibility, 66
 - Electronics power supply, failure of
 - PM-D F DC24V PROFIsafe, 118
 - EM 1 F-RO DC24V/AC24..230V/5A PROFIsafe
 - Block diagram, 208
 - Maximum response time, 236
 - Order Number, 203
 - Safety characteristics, 212
 - Technical specifications, 212
 - Terminal assignment, 206
 - Wiring diagram, 209
 - EM 4 F-DI/3 F-DO DC24V PROFIsafe
 - Block diagram, 162
 - Byte 7 of diagnostics data, 221
 - Diagnostic functions, 179
 - Discrepancy time, 165
 - Errors and Corrective Measures, 180
 - Fault types, 58
 - Front view, 160
 - Maximum response time, 234
 - Order number, 167
 - Order Number, 157
 - Parameters in STEP 7, 163
 - Readback time, 166
 - Safety characteristics, 182
 - Sensor supply, 167
 - Short-circuit test, 164
 - Special features of fault detection, 170, 173, 176
 - Switching grounded loads, 158
 - Technical specifications, 182
 - Terminal assignment, 161
 - Wiring diagram, 168, 171, 174, 177
 - EM 4 F-DO DC24V/2A PROFIsafe
 - Acknowledgment time, 202
 - Block Diagram, 191
 - Byte 7 of diagnostics data, 221
 - Diagnostic functions, 196
 - Diagnostics buffer, 197
 - Errors and Corrective Measures, 197
 - Fault types, 58
 - Front view, 189
 - Maximum response time, 235
 - Order Number, 186
 - Parameters in STEP 7, 195
 - Readback time, 195
 - Safety characteristics, 200
 - Switching grounded loads, 188
 - Technical specifications, 200
 - Terminal assignment, 190
 - Wiring Diagram, 192
 - EM 4/8 F-DI DC24V PROFIsafe
 - Acknowledgment time, 155
 - Applications, 131
 - Block diagram, 125
 - Byte 7 of diagnostics data, 149
 - Diagnostic functions, 149
 - Diagnostics buffer, 150
 - Discrepancy time, 129
 - Errors and corrective measures, 150
 - Fault types, 58
 - Front view, 123
 - Input delay, 127
 - Maximum response time, 233
 - Order number, 122
 - Parameters in STEP 7, 126
 - Safety characteristics, 153
 - Sensor supply, 133, 135, 145
 - Short-circuit test, 127

- Special Features for Fault Detection, 138, 141, 144, 148
 - Special features of fault detection, 134
 - Technical specifications, 153
 - Terminal assignment, 124
 - Wiring diagram, 136, 139, 141, 143, 145, 146, 147
 - Wiring Diagram, 133
 - EM 4F-DI/3F-DO DC24V PROFIsafe
 - Supported interface modules, 157
 - EMC, 66
 - Emission
 - of radio interference, 69
 - Environmental conditions, 70
 - Climatic, 72
 - Mechanical, 71
 - ET 200S
 - Commissioning, 21
 - Distributed I/O system, 15
 - External protective circuit, 67
 - protection from overvoltage, 67
 - ET 200S with fail-safe modules
 - Configuring, 23
 - External auxiliary supply missing
 - EM 4 F-DI/3 F-DO DC24V PROFIsafe, 179
 - EM 4 F-DO DC24V/2A PROFIsafe, 196
 - EM 4/8 F-DI DC24V PROFIsafe, 149
 - PM-D F DC24V PROFIsafe, 118
 - PM-E F pm DC24V PROFIsafe, 91
 - PM-E F pp DC24V PROFIsafe, 107
- F**
- F Configuration Pack, 30
 - F monitoring time
 - EM 4 F-DI/3 F-DO DC24V PROFIsafe, 163
 - EM 4 F-DO DC24V/2A PROFIsafe, 195
 - EM 4/8 F-DI DC24V PROFIsafe, 126
 - PM-D F DC24V PROFIsafe, 117
 - PM-E F pm DC24V PROFIsafe, 89
 - PM-E F pp DC24V PROFIsafe, 106
 - F_destination_address, 41
 - EM 4 F-DI/3 F-DO DC24V PROFIsafe, 163
 - EM 4 F-DO DC24V/2A PROFIsafe, 195
 - EM 4/8 F-DI DC24V PROFIsafe, 126
 - PM-D F DC24V PROFIsafe, 117
 - PM-E F pm DC24V PROFIsafe, 89
 - PM-E F pp DC24V PROFIsafe, 106
 - F_source_address, 41
 - Fail-safe automation systems, 15
 - Fail-Safe Electronic Module
 - supported terminal modules, 26
 - Fail-safe module
 - Reintegration, 54
 - Fail-safe motor starters
 - Configuration example, 25
 - Fail-safe potential groups
 - Configuration rules, 24
 - Fail-safe value output
 - for fail-safe modules, 54
 - Fault
 - EM 4 F-DO DC24V/2A PROFIsafe, 196
 - EM 4/8 F-DI DC24V PROFIsafe, 149
 - Fault detection
 - EM 4 F-DI/3 F-DO DC24V PROFIsafe, 170, 173, 176
 - EM 4/8 F-DI DC24V PROFIsafe, 134, 138, 141, 144, 148
 - Fault reaction
 - of F-modules, 53
 - Fault types
 - of F-modules, 58
 - F-CPU
 - Addresses Occupied by Useful Data, 39
 - F-inputs
 - Assignment, 135, 144, 167
 - FM approval, 63
 - F-modules, 16
 - Address assignment in the F-CPU, 39
 - available, 18
 - Configuring, 30
 - Dimension drawings, 227
 - Fault reaction, 53
 - inserting and removing, 48
 - insertion and removal during operation, 49
 - Installation dimensions, 44
 - installing, 44
 - Mixing with standard modules, 23
 - Output fail-safe values, 54
 - Parameter Assignment, 30
 - Parameter length, 29
 - possible uses, 16
 - Response times, 231
 - Use in F-systems, 16
 - wiring, 47
 - F-Power Modules
 - supported terminal modules, 26
 - F-Systems, 15
 - example configuration, 18
 - functional extra-low voltage
 - safe, 45
 - Functions
 - for diagnostics, 55
 - Fuse, external
 - PM-E F pm DC24V PROFIsafe, 85

PM-E F pp DC24V PROFIsafe, 105

G

General Technical Specifications, 61
 Grounding bus, 25
 Guide
 to manual, 6

I

I&M, 33
 I/O system
 Distributed, 15
 Identification data, 33
 IEC 61131, 64
 Information
 About this manual, 3
 Input delay, 50
 EM 4/8 F-DI DC24V PROFIsafe, 126, 127
 Input signals
 Capacitive crosstalk, 81
 Inserted F-module (dimension drawing)
 With terminal modules, 227
 Inserting
 F-Module, 48
 Insertion and removal
 F-modules during operation, 48
 Installation dimension
 F-modules, 44
 Installing
 F-modules, 44
 interconnecting
 of power modules, 25
 Interface module
 Can be used for ET 200S, 19
 Interference
 pulse-shaped, 66
 sinusoidal, 69
 Internal error
 EM 4 F-DI/3 F-DO DC24V PROFIsafe, 179
 PM-D F DC24V PROFIsafe, 118
 PM-E F pm DC24V PROFIsafe, 91
 PM-E F pp DC24V PROFIsafe, 107
 reaction to, 59
 Internal sensor supply, 127, 164
 Internet
 Service & Support, 8
 IP20, 73
 Isolation stability, 73
 Isolation test voltages, 73

L

Lag requirement
 of actuators, 51
 LED display
 Diagnostics, 56
 of faults, 56
 Limitation Maximum configuration, 30
 line cross-section, 45
 Literature, additional, 5
 Load current supply, failure
 PM-D F DC24V PROFIsafe, 118
 Load voltage missing, 58
 Loads
 capacitive switching, 90, 166, 195
 Switching grounded, 80

M

Machine protection
 Applications in, 56
 Maintenance data, 33
 Manual
 Contents, 6
 Purpose, 3
 Scope, 3
 Marking for Australia, 64
 Maximum configuration
 ET 200S with F-modules, 29
 Limitation, 30
 per potential group, 30
 Maximum response time
 EM 1 F-RO DC24V/AC24..230V/5A
 PROFIsafe, 236
 EM 4 F-DI/3 F-DO DC24V PROFIsafe, 234
 EM 4 F-DO DC24V/2A PROFIsafe, 235
 EM 4/8 F-DI DC24V PROFIsafe, 233
 PM-D F DC24V PROFIsafe, 232
 PM-E F pm DC24V PROFIsafe, 231
 PM-E F pp DC24V PROFIsafe, 232
 Mechanical conditions
 permitted, 71
 Test method, 71
 Mixing standard and F-modules, 23
 Module diagnostics, 59
 Module failure
 reaction to, 59
 Module fault
 Diagnostic Message, 59
 Module properties
 Parameter Assignment, 30
 Module replacement

- PROFIsafe address setting, 49
- Modules
 - fail-safe, 16
- Monitoring time
 - EM 4 F-DI/3 F-DO DC24V PROFIsafe, 163
 - EM 4 F-DO DC24V/2A PROFIsafe, 195
 - EM 4/8 F-DI DC24V PROFIsafe, 126
 - PM-D F DC24V PROFIsafe, 117
 - PM-E F pm DC24V PROFIsafe, 89
 - PM-E F pp DC24V PROFIsafe, 106
- Mounting Rails
 - supported, 47

N

- NAMUR recommendation
 - Power supply requirements, 46
- Number of modules
 - ET 200S with F-modules, 29

O

- of radio interference
 - Emission, 69
- Optional package
 - S7 Distributed Safety, 30
 - S7 F Systems, 30
- Order numbers
 - of accessories, 229
- Output
 - Status display, 212
- Output signals
 - Capacitive crosstalk, 81
- Overall width
 - ET 200S, 29
- Overload, 58
 - EM 4 F-DO DC24V/2A PROFIsafe, 193, 196
 - PM-E F pm DC24V PROFIsafe, 86
- Overtemperature, 58
 - EM 4 F-DI/3 F-DO DC24V PROFIsafe, 179
 - EM 4 F-DO DC24V/2A PROFIsafe, 196
 - EM 4/8 F-DI DC24V PROFIsafe, 149
 - PM-D F DC24V PROFIsafe, 118
 - PM-E F pm DC24V PROFIsafe, 91
 - PM-E F pp DC24V PROFIsafe, 107

P

- Parameter
 - EM 4 F-DO DC24V/2A PROFIsafe, 195
 - EM 4/8 F-DI DC24V PROFIsafe, 126

- PM-D F DC24V PROFIsafe, 117
- PM-E F pm DC24V PROFIsafe, 89
- PM-E F pp DC24V PROFIsafe, 106
- Parameter assignment
 - F-modules, 30
 - Module properties,
 - of the safety function, 19
- Parameter assignment error, 58
 - EM 4 F-DI/3 F-DO DC24V PROFIsafe, 179
 - EM 4 F-DO DC24V/2A PROFIsafe, 196
 - EM 4/8 F-DI DC24V PROFIsafe, 149
 - PM-D F DC24V PROFIsafe, 118
 - PM-E F pm DC24V PROFIsafe, 91
 - PM-E F pp DC24V PROFIsafe, 107
- Parameters
 - EM 4 F-DI/3 F-DO DC24V PROFIsafe, 163
- Passivation, 54, 76
- Performance Level (PL)
 - achievable, 19
- PM-D F DC24V PROFIsafe, 27
 - Block Diagram, 117
 - Byte 7 of diagnostics data, 222
 - Diagnostic functions, 118, 118
 - Errors and Corrective Measures, 119
 - Fault types, 58
 - Front view, 115
 - Maximum response time, 232
 - Order Number, 113
 - Parameters in STEP 7, 117
 - Safety characteristics, 120
 - Technical specifications, 120
 - Terminal assignment, 116
- PM-E DC24..48V, 27
- PM-E DC24..48V/AC24..230V, 27
- PM-E DC24V, 27
- PM-E F 24 VDC PROFIsafe
 - Acknowledgment time, 121
- PM-E F pm DC24V PROFIsafe, 27
 - Acknowledgment time, 97
 - Block Diagram, 84
 - Byte 7 of diagnostics data, 221
 - Diagnostic functions, 91
 - Errors and Corrective Measures, 92
 - Fault types, 58
 - Front view, 82
 - Maximum response time, 231
 - Order Number, 77
 - Parameters in STEP 7, 89
 - Readback time, 90
 - Relay output, 85
 - Safety characteristics, 93
 - Technical specifications, 93

- Terminal assignment, 83
 - Wiring Diagram, 85
 - PM-E F pp DC24V PROFIsafe, 27
 - Acknowledgment time, 111
 - Block Diagram, 104
 - Byte 7 of diagnostics data, 222
 - Diagnostic Functions, 107
 - Errors and Corrective Measures, 108
 - Fault types, 58
 - Front view, 102
 - Maximum response time, 232
 - Order Number, 98
 - Parameters in STEP 7, 106
 - Relay output, 105
 - Safety characteristics, 109
 - Technical specifications, 109
 - Terminal assignment, 103
 - Wiring Diagram, 105
 - Wiring the ground conductor, 99
 - Positioning
 - of power modules, 25
 - possible uses
 - F-modules, 16
 - Potential group
 - Configuration example, 23
 - Maximum configuration, 30
 - new, 25
 - Power failure
 - ride-through requirements, 46
 - Power module
 - fail-safe, 16
 - Positioning and interconnecting, 25
 - supported electronic modules, 27
 - supported motor starters, 27
 - Power supply
 - Requirements, 46
 - Power supply to standard ET 200S module
 - with power module, 78
 - Probability
 - Dangerous faults, 50
 - Product
 - Overview, 15
 - PROFIBUS
 - Standard, 64
 - PROFIsafe, 16
 - Address, 41, 49
 - Address switch, 41
 - PROFIsafe Address Assignment, 41
 - PROFIsafe address assignment
 - Rules, 43
 - PROFIsafe address setting
 - when replacing a module, 49
 - Proof-test interval, 50, 131
 - For safety characteristics, 75
 - Protection class, 73
 - P-switch, 105
 - Pulse-shaped interference, 66
 - Purpose of this Manual, 3
 - PWR LED, 56
 - PM-D F DC24V PROFIsafe, 118
 - PM-E F pm DC24V PROFIsafe, 91
 - PM-E F pp DC24V PROFIsafe, 107
- ## R
- Rated voltage, 73
 - Reaction
 - to module failure, 59
 - with discrepancy, 128
 - Reaction of the F-DI module
 - to communication errors, 55
 - Readback time
 - EM 4 F-DI/3 F-DO DC24V PROFIsafe, 166
 - EM 4 F-DO DC24V/2A PROFIsafe, 195
 - PM-E F pm DC24V PROFIsafe, 89
 - Reading out
 - Diagnostic functions, 59
 - Reading Out Diagnostics Data, 217
 - Recycling, 6
 - Reduction
 - of vibration, 71
 - Reintegration
 - fail-safe module, 54
 - Relay output
 - PM-E F pm DC24V PROFIsafe, 85
 - PM-E F pp DC24V PROFIsafe, 105
 - Relays, two
 - on one digital output, 193
 - Requirements
 - Sensors and actuators, 50
 - Response time
 - Definition, 231
 - F-modules, 231
 - ride-through
 - minimum for power failure, 46
- ## S
- S7 Distributed Safety
 - example configuration, 18
 - Optional package, 19, 30
 - S7 F Systems
 - Optional package, 30

- Safe functional extra-low voltage, 45
- Safe shutdown, 27
- Safe state, 53
- Safety characteristics
 - EM 1 F-RO DC24V/AC24..230V/5A PROFIsafe, 212
 - EM 4 F-DI/3 F-DO DC24V PROFIsafe, 182
 - EM 4 F-DO DC24V/2A PROFIsafe, 200
 - EM 4/8 F-DI DC24V PROFIsafe, 153
 - PM-D F DC24V PROFIsafe, 120
 - PM-E F pm DC24V PROFIsafe, 93
 - PM-E F pp DC24V PROFIsafe, 109
 - Scope, 75
- Safety class, 131
 - achievable, 19, 27
 - achieve with EM 4/8 F-DI DC24V PROFIsafe, 122, 132
 - achieved with EM 4 F-DO DC24V/2A PROFIsafe, 186
 - achieved with PM-D F DC24V PROFIsafe, 114
- Safety Class
 - achieve with EM 4 F-DI/3 F-DO DC24V PROFIsafe, 158
 - achieve with EM 4/8 F-DI DC24V PROFIsafe, 167
- Safety function
 - Parameter Assignment, 19
- Safety mode, 41
- Safety-related shutdown, 58, 100
 - PM-E F pm DC24V PROFIsafe, 91
 - PM-E F pp DC24V PROFIsafe, 107
 - Standard output modules, 79
- Saving faults, 53
- Scope
 - of this manual, 3
- Sensor evaluation
 - EM 4 F-DI/3 F-DO DC24V PROFIsafe, 163, 169, 172, 175
 - EM 4/8 F-DI DC24V PROFIsafe, 126, 134, 137, 140, 143, 146, 147
- Sensor interconnection
 - 1-channel, 126, 163
 - 2-channel equivalent, 126, 163
 - 2-channel, non-equivalent, 126, 146, 163
 - EM 4 F-DI/3 F-DO DC24V PROFIsafe, 163, 172, 175
 - EM 4/8 F-DI DC24V PROFIsafe, 126, 140, 143, 147
- Sensor signal
 - Duration Requirements, 50
- Sensor supply
 - EM 4 F-DI/3 F-DO DC24V PROFIsafe, 167, 169
 - EM 4/8 F-DI DC24V PROFIsafe, 133, 134, 135, 137, 145
 - internal, 164
 - Internal, 127
- Sensor voltage missing, 58
- Sensors
 - external power supply, 45
 - Requirements, 50
- Service & Support
 - In the Internet, 8
- Setting
 - PROFIsafe address switch, 42
- SF LED, 56
 - EM 4 F-DO DC24V/2A PROFIsafe, 189
 - PM-D F DC24V PROFIsafe, 115
 - PM-E F pm DC24V PROFIsafe, 82
 - PM-E F pp DC24V PROFIsafe, 102
- SFB 54, 218
- SFC 13, 59, 218
- SFC 59, 218
- Shielded cables, 127
- Shipbuilding approval, 64
- Shipping and storage conditions, 70
- Short circuit
 - EM 4 F-DI/3 F-DO DC24V PROFIsafe, 169
 - EM 4/8 F-DI DC24V PROFIsafe, 134
 - PM-D F DC24V PROFIsafe, 118
 - PM-E F pp DC24V PROFIsafe, 107
- Short-circuit, 58
 - EM 4 F-DI/3 F-DO DC24V PROFIsafe, 179
 - EM 4 F-DO DC24V/2A PROFIsafe, 196
 - EM 4/8 F-DI DC24V PROFIsafe, 137, 149
 - on outputs of standard output modules, 79, 100, 187, 204
 - PM-E F pm DC24V PROFIsafe, 91
- Short-circuit test, 50, 56
 - EM 4 F-DI/3 F-DO DC24V PROFIsafe, 163, 164, 169, 172, 175, 179
 - EM 4/8 F-DI DC24V PROFIsafe, 126, 127, 134, 137, 140, 143, 146, 147, 149
- shutdown
 - Safe, 27
- SIMATIC product
 - Use in Industry, 65
- Sinusoidal interference, 69
- Slave diagnostics, 56
 - Reading out, 59
- Spare parts case, 49
- Standard modules
 - Mixing with F-modules, 23
- Standard output modules
 - Safety-related shutdown, 79, 100, 187, 204
- Standards, 65
- state

- Safe, 53
- Status display
 - Output, 212
- Storage conditions, 70
- Structure
 - ET 200S with fail-safe modules, 23
 - ET 200S with fail-safe motor starters, 24
- Supply voltage, failure of
 - EM 4 F-DI/3 F-DO DC24V PROFIsafe, 179
 - EM 4/8 F-DI DC24V PROFIsafe, 149
 - PM-D F DC24V PROFIsafe, 118
 - PM-E F pm DC24V PROFIsafe, 91
 - PM-E F pp DC24V PROFIsafe, 107
- Support, additional, 7
- Surge filter, 67
- Switching grounded loads
 - using PM-E F pm DC24V PROFIsafe, 80
 - with EM 4 F-DI/3 F-DO DC24V PROFIsafe, 158
 - With EM 4 F-DO DC24V/2A PROFIsafe, 188

T

- Technical specifications
 - EM 1 F-RO DC24V/AC24..230V/5A PROFIsafe, 212
 - EM 4 F-DI/3 F-DO DC24V PROFIsafe, 182
 - EM 4 F-DO DC24V/2A PROFIsafe, 200
 - EM 4/8 F-DI DC24V PROFIsafe, 153
 - PM-D F DC24V PROFIsafe, 120
 - PM-E F pm DC24V PROFIsafe, 93
 - PM-E F pp DC24V PROFIsafe, 109
- Technical Specifications
 - General, 61
- Technical Support, 7
- Terminal assignment
 - EM 1 F-RO DC24V/AC24..230V/5A PROFIsafe, 206
 - EM 4 F-DI/3 F-DO DC24V PROFIsafe, 161
 - EM 4 F-DO DC24V/2A PROFIsafe, 190
 - PM-D F DC24V PROFIsafe, 116
 - PM-E F pm DC24V PROFIsafe, 83
 - PM-E F pp DC24V PROFIsafe, 103
 - Terminal modules, 48
- Terminal Assignment
 - EM 4/8 F-DI DC24V PROFIsafe, 124
- Terminal module, 116, 124, 161
 - Terminal assignment, 48
- Terminal module (dimension drawing)
 - With inserted F-module, 227
- Test, mechanical
 - F-modules, 71
- TM-E30C44-01, 124, 190, 206

- TM-E30C46-A1, 124, 161
- TM-E30S44-01, 124, 190, 206
- TM-E30S46-A1, 124, 161
- TM-P30C44-A0, 83
- TM-P30S44-A0, 83
- TM-PF30S47-F1, 116
- Total current
 - per potential group, 30
- Training center, 7
- TÜV certificate, 65
- Two Relays
 - on one digital output, 86
- Type of protection IP20, 73

U

- UL approval, 62
- Use of ET 200S
 - In industry, 65
 - In residential areas, 65

V

- Vibration
 - Reduction, 71
- VsF LED, 56
 - EM 4 F-DI/3 F-DO DC24V PROFIsafe, 179

W

- Wire break, 58
 - Detection with two relays on one digital output, 194
 - EM 4 F-DO DC24V/2A PROFIsafe, 195, 196
 - PM-E F pm DC24V PROFIsafe, 86
- Wiring
 - F-modules, 47
- Wiring diagram
 - EM 1 F-RO DC24V/AC24..230V/5A PROFIsafe, 209
 - EM 4 F-DI/3 F-DO DC24V PROFIsafe, 168, 171, 174, 177
 - EM 4/8 F-DI DC24V PROFIsafe, 136, 139, 141, 143, 145, 146, 147
 - PM-E F pp DC24V PROFIsafe, 105
- Wiring Diagram
 - EM 4 F-DO DC24V/2A PROFIsafe, 192
 - EM 4/8 F-DI DC24V PROFIsafe, 133
 - PM-E F pm DC24V PROFIsafe, 85
- Wiring the ground conductor
 - PM-E F pp DC24V PROFIsafe, 99

