

CLICKER 4 for TMPM4K SCHEMATIC

v103

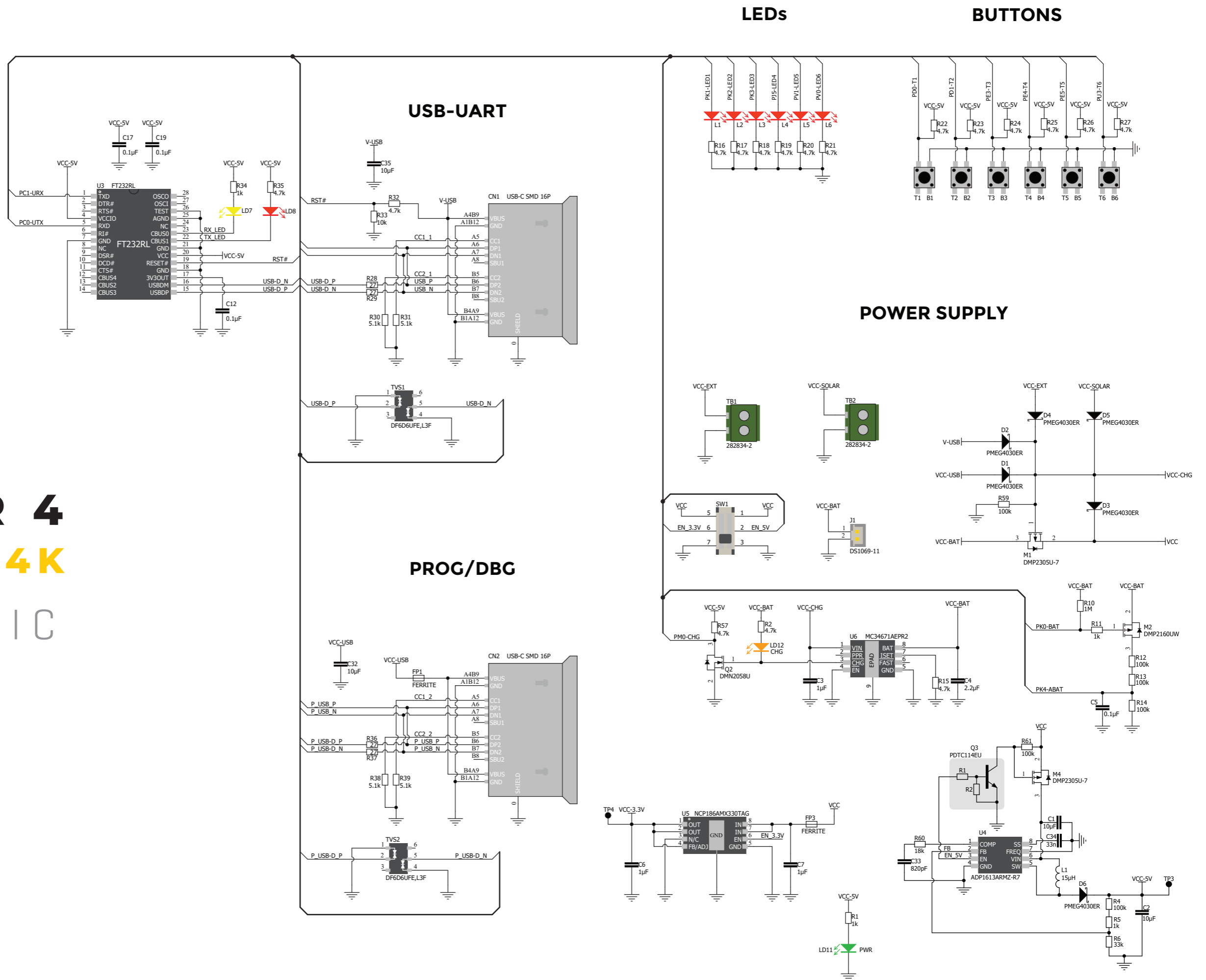

MIKROBUS™

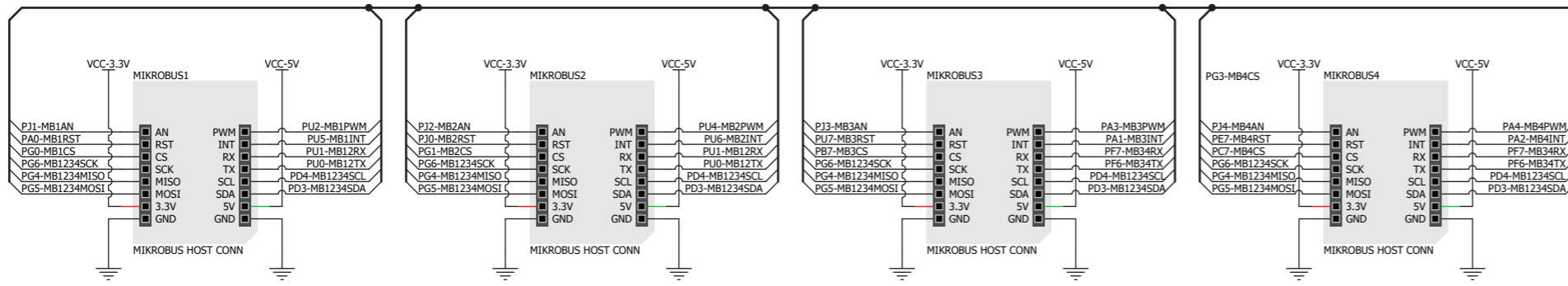

HEADERS

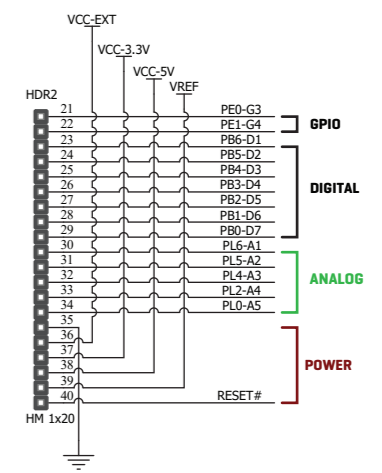
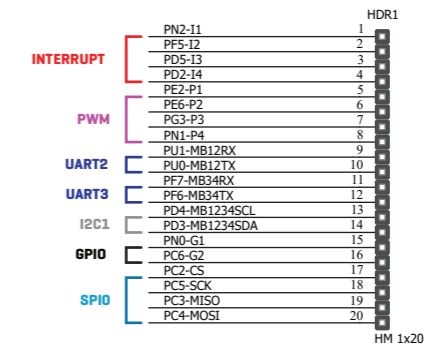

MCU

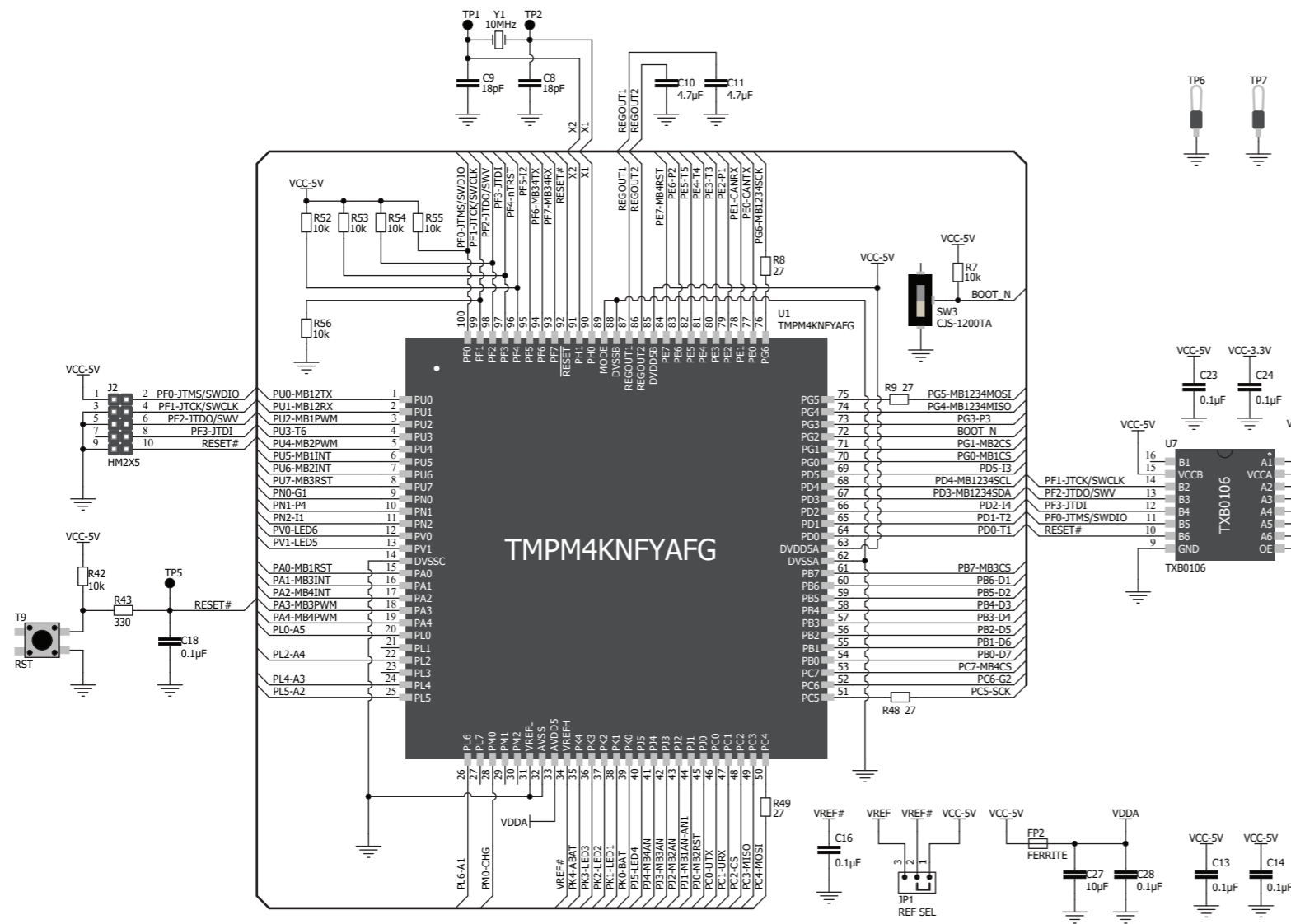

ON-BOARD DEBUGGER

