

AD 699 946

INTERFACE MESSAGE PROCESSORS FOR THE ARPA  
COMPUTER NETWORK

Frank E. Heart

Bolt Beranek and Newman, Incorporated  
Cambridge, Massachusetts

January 1970

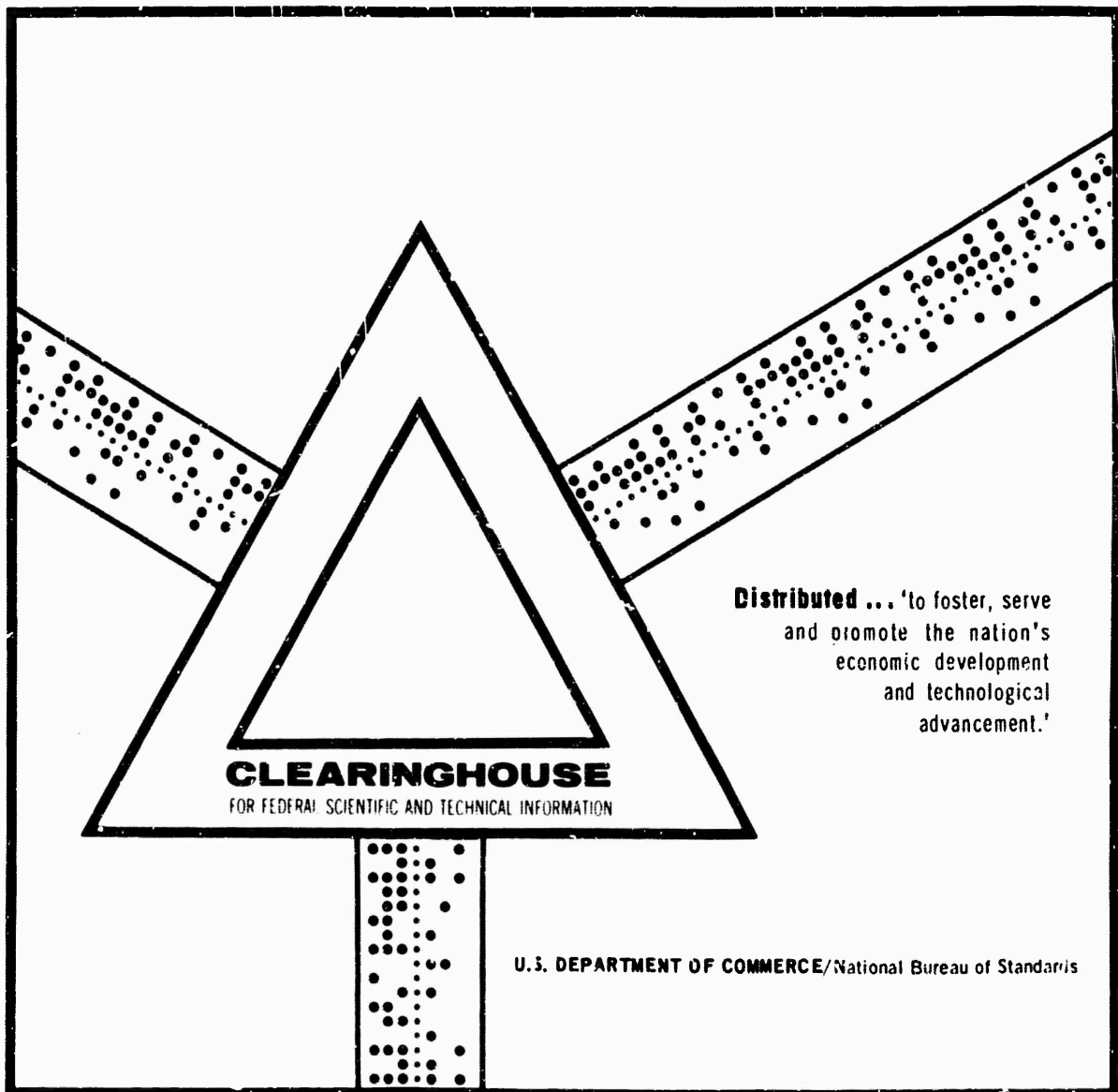

This document has been approved for public release and sale.

Report No. 1923

January 1970

AD699946

INTERFACE MESSAGE PROCESSORS FOR  
THE ARPA COMPUTER NETWORK

QUARTERLY TECHNICAL REPORT NO. 4  
1 October 1969 to 31 December 1969

Principal Investigator: Mr. Frank E. Heart  
Telephone (617) 491-1850, Ext. 470

Sponsored by  
Advanced Research Projects Agency  
ARPA Order No. 1260

Contract No. DAHC15-69-C-0179  
Effective Date: 2 January 1969  
Expiration Date: 31 December 1970  
Contract Amount: \$1,430,093.00

This document has been approved  
for public release and sale; its  
distribution is unlimited

Submitted to:

Director  
Advanced Research Projects Agency  
Washington, D.C. 20301  
Attention: Dr. L.G. Roberts

Reproduced by the  
CLEARINGHOUSE  
for Federal Scientific & Technical  
Information Springfield Va. 22151

D D C  
RECEIVED  
FEB 2 1970  
REGISTERED

Report No. 1928

January 1970

INTERFACE MESSAGE PROCESSORS FOR  
THE ARPA COMPUTER NETWORK

QUARTERLY TECHNICAL REPORT NO. 4  
1 October 1969 to 31 December 1969

Principal Investigator: Mr. Frank E. Heart  
Telephone (617) 491-1850, Ext. 470

Sponsored by  
Advanced Research Projects Agency  
ARPA Order No. 1260

Contract No. DAHC15-69-C-0179  
Effective Date: 2 January 1969  
Expiration Date: 31 December 1970  
Contract Amount: \$1,430,093.00

Submitted to:

Director  
Advanced Research Projects Agency  
Washington, D.C. 20301  
Attention: Dr. L.G. Roberts

TABLE OF CONTENTS

	page
SECTION 1. INTRODUCTION .....	1
2. SOFTWARE DEVELOPMENT .....	2
3. HARDWARE DEVELOPMENT .....	6
4. PHONE LINE TEST PROGRAM .....	7
5. HOST PROTOCOL .....	8

## 1. INTRODUCTION

This Quarterly Technical Report No. 4 describes several aspects of our progress on the ARPA computer network during the fourth quarter of 1969. During this period, the installation of a four-node initial network connecting UCLA, UCSB, SRI, and Utah was completed on schedule. A second version of the operational IMP program which replaced the earlier version was released on November 2. The continuing software development activity is described in Section 2. Work was also completed on the implementation of a hardware add-on to the standard Host/IMP interface unit to drive a 2000-foot Host cable. This work is described in Section 3.

An initial version of a phone line test program was written during this quarter in order to obtain data on the performance of the wideband communication circuits. This program and our initial experience in using it is described in Section 4. A slight modification to the IMP's RFNM mechanism resulted from our discussions with the Hosts in the initial network. Our participation in the effort to develop a sensible Host protocol is described in Section 5.

## 2. SOFTWARE DEVELOPMENT

During this quarter, version two of the operational program was delivered to the sites. This new version incorporates most of the features previously described in our technical reports, such as a complete set of measurement facilities, and includes a new status reporting feature.

In order to incorporate these measurement facilities, we made a substantial effort to utilize the existing program routines. As a result, it was decided that the IMP should use the Host/IMP and IMP/Host routines to handle messages generated by or destined for an IMP and thus to treat these IMP messages as if they were Host messages.

An IMP message is distinguished from a Host message by a digit 1 in the FOR IMP or FROM IMP bit in the leader of the message. A message from an IMP is identified by a 1 in the FROM IMP bit position in the leader; likewise, a message to an IMP is identified by a 1 in the FOR IMP bit position of the leader. The particular *type* of IMP message is designated by the two Host bits in the leader. The RFNM mechanism works in the usual fashion for IMP messages. A detailed description of the formats for communication between a Host and an IMP will be incorporated into BBN Report No. 1822, the Host Specification. A typical Host will ordinarily have little need to communicate directly with an IMP.

The various types of messages to and from an IMP are illustrated in Figure 1 and are described below:

- 1) TELETYPE - FOR IMP messages of type 0 are printed out on the IMP teletype. FROM IMP messages of type 0 are generated at the IMP teletype.
- 2) DEBUG - DEBUG messages are used to examine, modify, and report the contents of registers in core. Messages to and from DEBUG are designated by type 1. The IMP software prevents the unauthorized use of the DEBUG program.
- 3) TRACE - When this feature is activated (using PARAMETER CHANGE), the IMP program records and transmits information about packets that have been marked for tracing. This FROM IMP information is designated by type 2.
- 4) STATISTICS - When this feature is activated, the IMP program performs measurements on network activity and transmits this information to a designated destination. This FROM IMP information is designated by type 3.
- 5) PARAMETER CHANGE - An authorized Host can send a message to an IMP that causes preselected IMP parameters to be modified. This FOR IMP message should be of type 2.
- 6) DISCARD - The IMP program will discard any FOR IMP message of type 3.

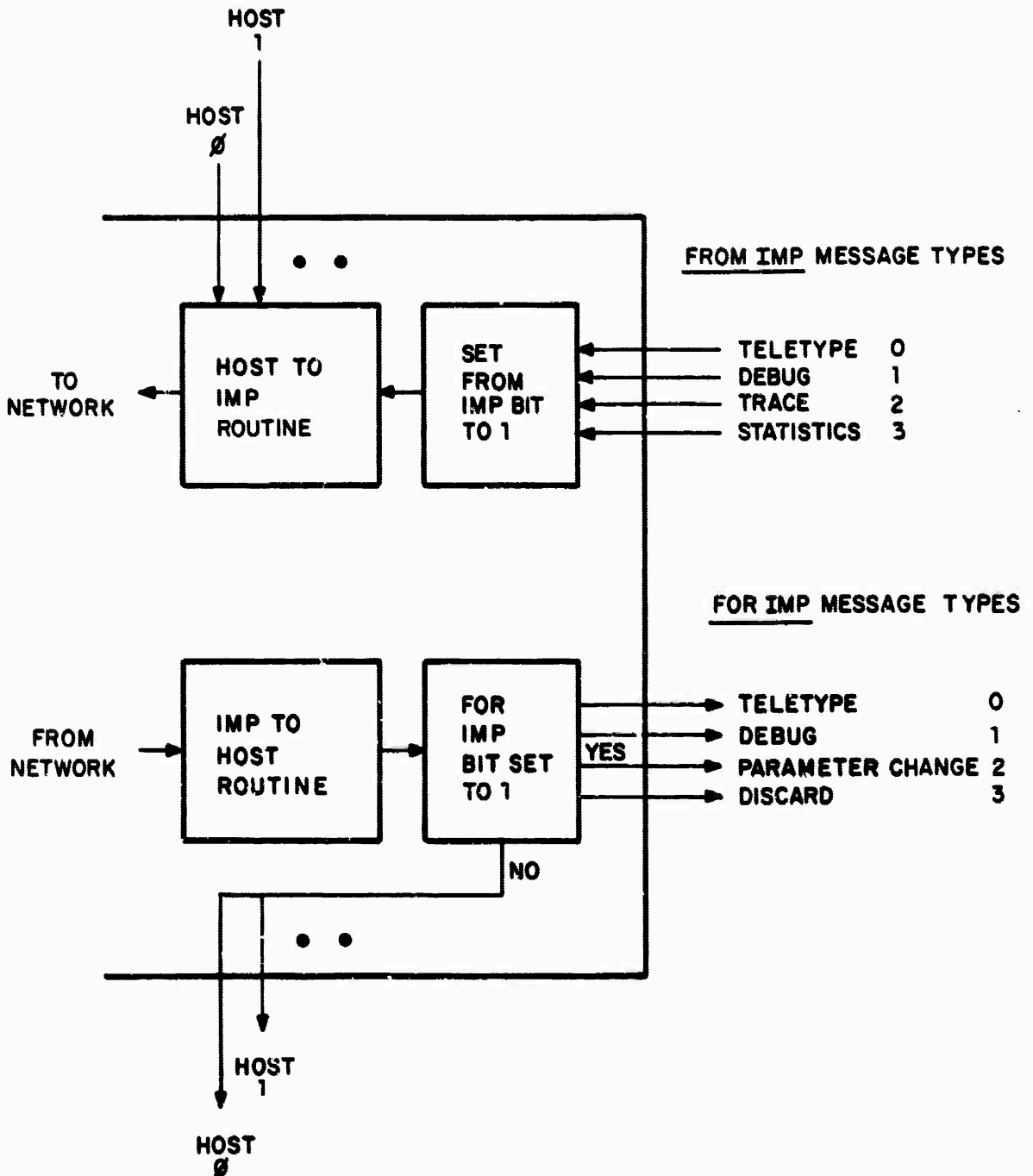

FIG. 1. COMMUNICATION WITH AN IMP.



The status reporting mechanism provides current information about the condition of the network. When activated at a given IMP, this mechanism periodically forms a message that records the status of the Host, the phone lines, and the sense switches. A new status message is formed and transmitted every ten minutes to the control center and also whenever live/dead status changes occur. These messages are printed on the IMP teletype at the control center in the following form:

IMP #	HOST STATUS	LINE 1 STATUS	LINE 2 STATUS	LINE 3 STATUS	SENSE SWITCH STATUS
----------	----------------	------------------	------------------	------------------	---------------------------

The Host and line status entries denote the respective live/dead conditions. In addition, the line status entries also denote the number of retransmitted packets on that line in the last twenty recorded tries. The sense switch status entry records the position of each sense switch. The format will be modified to include additional lines and hosts as needed. An up-to-date record of the network status is thus available at the control center whenever this feature is activated.

### 3. HARDWARE DEVELOPMENT

During the last quarter, we developed a prototype distant Host driver that may be added to the standard interface to permit connection of a Host to an IMP at distances up to 2000 ft. The inclusion of a distant Host driver does not change the logical operation of the Host interface, although the actual line signals are different from those of a local Host connection.

The distant Host driver performs two functions. It accommodates a shift in ground potential between two distant systems and it provides a signaling method having sufficient power and noise resistance to communicate over a 2000-foot separation. The reference level for the logic signals is shifted in the driver unit from the IMP signal reference to the Host signal reference by transformer coupling. The Host reference is then carried to the distant Host driver through the cable shield. Within the distant Host cable, signals are transmitted on twisted pairs as balanced differential signals that permit rejection of induced common mode noise.

A prototype driver has been successfully tested on a 2000-foot cable loop and production versions will be available early in the spring.

#### 4. PHONE LINE TEST PROGRAM

In the last quarter, we designed and implemented a test program to obtain data on the performance of the fifty kilobit communication circuits. This particular test program continuously transmits short packets (88 bits) on each phone line and keeps track of arriving packets in a way that allows the real time occurrence of packet errors to be recorded on the console teletype. In addition, it records, for arriving packets, a burst length histogram of successive correct packets and successive packets in error.

The basic operation of the program is as follows. The program sends out in each packet one word of data that contains a 16-bit count. The count is incremented by one for each transmitted packet. When a packet arrives without error, the new count is compared with the last received count and any difference greater than one is taken to indicate an error burst.

Two different types of line test can be run. A two-way line test may be run whenever the remote modem is looped back. Two one-way line tests may be run whenever the remote modem is not looped and another copy of the test program is running the neighboring IMP.

Preliminary two-way test data, obtained during a 27-hour period on the UCSB-SRI line (looped back at SRI), indicates approximately one packet per 20,000 in error. However, subsequent tests have uncovered a 100% variation in this number - apparently due to many unusually long periods of time (on the order of hours) with no detected errors. The distribution of error bursts appears to be concentrated in the range between one and seven packets.

## 5. HOST PROTOCOL

Under this contract, the primary BBN responsibility has been the implementation of an IMP subnet and the related connection of the subnet to the Host computers. In addition to this development effort, the utility of the ARPA Network is dependent upon the formulation of sensible Host protocols. The difficulty of this task reflects the basic underlying research problem of how local and remote computer programs should interact. Informal efforts to generate a Host protocol have been in progress for some time, and an informal "Network Working Group" exists as one forum for discussions. In the last quarter, BBN has increased its participation in these efforts\* and we expect to continue this participation in the next quarter.

It is apparent that the development of a Host protocol involves some interaction between BBN and the Hosts on the subject of IMP protocol. As one result of this interaction, a minor change is being made in the RFNM mechanism to simplify an aspect of Host/Host traffic control. A Host that wishes to stop the flow of incoming traffic on a given link, or on all links, simply notifies its IMP via a control message. The IMP then sets a special control bit in the next RFNM it returns on that link. It is the responsibility of the transmitting Host to interpret this information and stop the flow of traffic. The IMP will not enforce this blockage, as the IMP will unblock the link as soon as the RFNM returns. A Host-to-Host message is required to restart the flow on this link. We anticipate other cases where small IMP protocol changes will be useful and we will try to be responsive to such needs.

---

\*Much of our discussion has been with S. Crocker of UCLA and we acknowledge his contribution.

More generally, we have been participating in the consideration of several Host protocol issues. For example:

1. While we have come to believe that the IMP should not do character set conversions, there is still an immediate need for a network-wide teletype character set into and out of which each Host translates his messages. The choice is arbitrary, and the need for a decision has become urgent (already we see Hosts converting to the language of the destination). We recommend the adoption of 8-bit ASCII with the 8th bit (checksum bit) set to a 1, which is the IMP's internal character set. This choice has the small additional advantage that Hosts may send messages to local or remote IMP teletypes without an additional conversion. As network use develops, other standards (such as a display language) will be needed.
2. With regard to the user level of message control, we recommend the notion of user *ports* whereby a user may request to establish a port with a specific port number. The user may request to send messages from one port to another, or to receive messages at a port from either a specific port or from any port. Standard programs in each Host (the logger, the message box, etc.) would have standard published numbers and would be generally available for use. We hope to participate in further detailing of this approach.
3. A potential conflict exists over how to handle echoing. Local echoing is troublesome for systems that do not always echo the input; remote echoing is both troublesome for systems whose hardware automatically echoes and may introduce undue echoing delay. This topic deserves further study.

At this point the initial network is installed and operational. New Hosts will be entering the network at a rate of one a month for the next several months. There is thus an urgent need for further work on Host protocol and for documents specifying formats and procedures for Host-to-Host communication.

## DOCUMENT CONTROL DATA - R &amp; D

(Security classification of title, body of abstract and indexing annotation must be entered when the overall report is classified)

1. ORIGINATING ACTIVITY (Corporate author)		2a. REPORT SECURITY CLASSIFICATION	
Bolt Beranek and Newman Inc. 50 Moulton Street Cambridge, Massachusetts 02138		UNCLASSIFIED	
3. REPORT TITLE		7b. GROUP	
QUARTERLY TECHNICAL REPORT NO. 4 1 October 1969 to 31 December 1969			
4. DESCRIPTIVE NOTES (Type of report and, inclusive dates)			
5. AUTHOR(S) (First name, middle initial, last name)			
Bolt Beranek and Newman Inc.			
6. REPORT DATE	7a. TOTAL NO. OF PAGES	7b. NO. OF REFS	
January 1970			
8a. CONTRACT OR GRANT NO.	9a. ORIGINATOR'S REPORT NUMBER(S)		
DAHC 15-69-C-0179	BBN Report No. 1928		
b. PROJECT NO.	9b. OTHER REPORT NO(S) (Any other numbers that may be assigned this report)		
c.			
d.			
10. DISTRIBUTION STATEMENT			
11. SUPPLEMENTARY NOTES		12. SPONSORING MILITARY ACTIVITY	
		Advanced Research Projects Agency Washington, D.C. 20301	
13. ABSTRACT The basic function of the IMP computer network is to allow large existing time-shared (Host) computers with different system configurations to communicate with each other. Each IMP (Interface Message Processor) computer accepts messages for its Host from other Host computers and transmits messages from its Host to other Hosts. Since there will not always be a direct link between two Hosts that wish to communicate, individual IMPs will, from time to time, perform the function of transferring a message between Hosts that are not directly connected. This then leads to the two basic IMP configurations - interfacing between Host computers and acting as a message switcher in the IMP network. The message switching is performed as a store and forward operation. Each IMP adapts its message routine to the condition of those portions of the IMP network to which it is connected. IMPs regularly measure network performance and report in special messages to the network measurement center. Provision of a tracing capability permits the net operation to be studied comprehensively. An automatic trouble reporting capability detects a variety of network difficulties and reports them to an interested Host. An IMP can throw away packets that it has received but not yet acknowledged, transmitting packets to other IMPs at its own discretion. Self-contained network operation is designed to protect and deliver messages from the source Host to the destination Host.			

14. KEY WORDS	LINK A		LINK B		LINK C	
	ROLE	WT	ROLE	WT	ROLE	WT
Computers and Communication Store and Forward Communication ARPA Computer Network Honeywell DDP-516 IMP Program Design - IMP						