



RS-422 AND RS-485 APPLICATIONS EBOOK

A Practical Guide to Using RS-422 and RS-485 Serial
Interfaces

v. 1.0





International Headquarters

Mfg. Co. Inc.

707 Dayton Road

Ottawa, IL 61350 USA

Phone: (815) 433-5100 General Fax: (815) 433-5105

Website: www.bb-smartworx.com

European Headquarters

Westlink Commercial Park

Oranmore, Co. Galway, Ireland

Phone: (+353) 91-792444 Fax: (+353) 91-792445

Website: www.bb-smartworx.com

Revision – Original –October 2010

©2010 No part of this publication may be reproduced or transmitted in any form or by any means, electronic or mechanical, including photography, recording, or any information storage and retrieval system without written consent. Information in this manual is subject to change without notice, and does not represent a commitment on the part .

shall not be liable for incidental or consequential damages resulting from the furnishing, performance, or use of this manual.

All brand names used in this manual are the registered trademarks of their respective owners. The use of trademarks or other designations in this publication is for reference purposes only and does not constitute an endorsement by the trademark holder.

This document was created using Author-it, Microsoft Word, Adobe Acrobat, SnagIt and other software.

Table of Contents

RS-422 and RS-485 Applications eBook	1
Overview	5
Assumptions	6
What is RS-422/RS-485?	6
Data Transmission Signals	8
Unbalanced Data Transmission	9
Balanced Data Transmission.....	11
RS-422 and RS-485 Terminals and Designations	13
Common Mode Voltage.....	14
Tri-State Control.....	16
RTS Control.....	17
Send Data Control	18
Bit-wise Enable Timing Control	20
Other Tri-State Control Techniques	21
System Configuration	23
RS-422 Point-to-Point Connections	24
Network Topologies	25
Two-Wire Systems.....	25
Four-Wire Systems	27
Termination	27
Deciding whether to use termination	28
Example calculation to determine whether termination is necessary	29
Methods of Termination	29
Biasing an RS-485 Network.....	32
Example 1: Biasing when termination resistors are used	34
Example 2: Biasing when termination resistors are not used	36
Other Biasing and Terminating Considerations.....	38
Using Repeaters	39
Using Repeaters in a Master-Slave Network	40
Using Repeaters in Star, Ring and Tree Networks.....	41
Using Fractional Load Receivers to Extend Distance and Number of Nodes	42

Selecting RS-422 and RS-485 Cabling	43
Number of Conductors	43
Shielding	44
Cable Characteristics.....	45
Cable Length vs Data Rate	45
Attenuation vs Frequency	46
Using Cat 5 for RS-422/485	47
Transient Protection of RS-422 and RS-485 Systems	49
What does a surge look like?.....	49
Surge Specifications	50
Common Mode versus Differential Mode	52
When Ground is not really Ground	53
Transient Protection using Isolation	55
Isolation Theory	55
Isolation Devices	57
Transient Protection using Shunting	58
Shunting Theory	58
Connecting Signal Grounds	59
Shunting Devices	60
Combining Isolation and Shunting	60
Special Consideration for Fault Conditions.....	62
Choosing the right protection for your system	63
Software.....	65
RS-422 Systems.....	66
RS-485 Driver Control	66
RS-485 Receiver Control.....	68
Master-Slave Systems	68
Four Wire Master-Slave Systems	68
Two Wire Master-Slave Systems	70
Multi-Master RS-485 Systems	70
Systems with Port Powered Converters.....	71
RS-485 Devices	73
RS-232 to RS-485 Converters	74
PC Serial Interface Cards	75
USB to RS-422/485 Converters	76

Port Powered Converters	77
Repeaters	78
Optically Isolated RS-422/485 Devices	79
Sources of Additional Information.....	81
Global Engineering.....	81
List of EIA/TIA Standards	82
Integrated Circuit Manufacturers	82
Other sources of information	83
EIA Specification Summary	85
EIA-422 Specifications	85
EIA-485 Specifications	86
EIA-232 Specifications	86
EIA-423 Specifications	87
Comparison of RS-232, RS-423, RS-422 and RS-485 Specifications	87
EIA Standard RS-423 Data Transmission.....	89
Testing and Troubleshooting RS-422/485 Systems.....	91
Selecting RS-485 Devices	91
Troubleshooting Checklist	92
Troubleshooting Flowchart	93
RTS Control Timing Diagrams.....	95
Send Data Control Timing Diagrams.....	96
Bit-Wise Enable Timing Diagrams	97
Glossary of Terms	99
Index	130

CHAPTER 1

Overview

The purpose of this ebook is to describe the main elements of RS-422 and RS-485 data communications systems. The authors have attempted to cover enough technical details so that personnel will have the necessary information to be successful in designing, modifying or troubleshooting an RS-422 or RS-485 data communication system.

Since both RS-422 and RS-485 are data transmission systems that use balanced differential signals, it is appropriate to discuss both systems in the same publication. Throughout this document the generic terms of RS-422 and RS-485 are used when referring to equipment and systems based on the EIA/TIA-422 and EIA/TIA-485 Standards.

In This Chapter

Assumptions	6
What is RS-422/RS-485?	6
Data Transmission Signals	8
RS-422 and RS-485 Terminals and Designations	13
Common Mode Voltage.....	14
Tri-State Control	16

Assumptions

This writers of this ebook have based the content and level of detail on several assumptions. The first assumption is that the personnel reading and using the information in it will have an understanding of basic electricity and electronics. This includes an understanding of transistor inputs and outputs, current sourcing and sinking, the differences between analog and digital circuits, signal propagation, signal inversion, digital rise and fall times, input and output impedance, single-ended and differential voltage measurements, and other data communication-related electronic concepts. Some explanation of these concepts is included, but if the reader is unfamiliar with these areas, some additional study may be required.

The writers also assume that the users of this ebook will come from several different perspectives. Some may be using the material for designing new communications systems; others will be using it in the context of installing and commissioning systems; still others will be involved in maintaining, expanding and troubleshooting problems related to existing systems. This ebook may also be used in training and upgrading personnel.

What is RS-422/RS-485?

RS-422 and RS-485 are the common names for two serial communications standards. The standards, defined by the Electronics Industry Association, are more correctly named EIA/TIA-422 and EIA/TIA-485.

Communications systems based on RS-422 and RS-485 communicate digital information over twisted pair wire from transmitters to receivers. Devices can be up to 4000 feet (1220 meters) apart before repeaters are required. RS-422 drivers can transmit to up to 10 receivers. Up to 32 RS-485 transceivers can occupy a bus. RS-422/485 systems can communicate at rates up to 10 Mbps (though most systems operate at lower bit rates). Both systems utilize balanced outputs and differential inputs, which provide better noise immunity than single-ended systems such as RS-232. This results in the ability to

operate over longer distances at higher bit rates than links using RS-232.

RS-422's capabilities make it a good choice for extending the distance and speed of point-to-point connections. In situations where data must be communicated over long distances and through electrically noisy areas, RS-422 provides a higher reliability replacement for standards such as RS-232 .

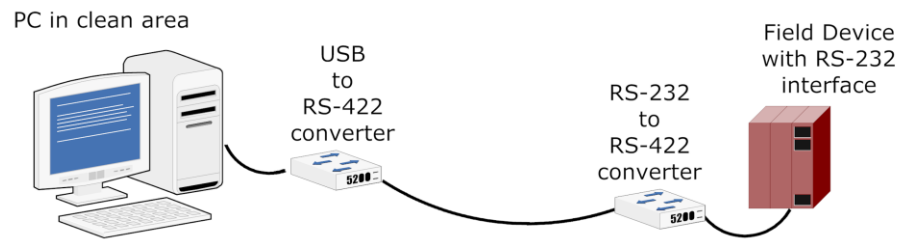

Figure 1: RS-422 Point-to-Point Link

RS-422 also makes it possible to create point-to-multipoint connections. In a point-to-multipoint arrangement the node originating the data (master) can broadcast data to several (slave) nodes at once. However, for the master to receive data back from each slave, RS-485 devices are required.

RS-485 can be used in two and four-wire networked systems. The tri-state capabilities of RS-485 transmitters enable multiple transceivers (transmitter/receiver pairs) to be connected to a two-wire multidrop bus. Alternately, a four-wire system can be used in which the master node driver is connected to all slave receivers and all slave drivers are connected to the master receiver.

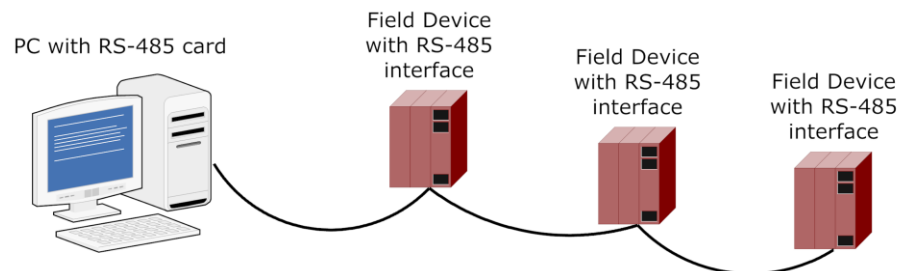

Figure 2: RS-485 Daisy Chain Network

RS-485 is used as the basis for many commercial and industrial data communications systems. Industry systems such as PROFIBUS, INTERBUS, and others are built on RS-485 technology. RS-422 was historically used in older Apple computers and printers, and in video editing equipment.

Often, end-users build systems themselves using RS-232 to RS-422/485 converters, RS-485 smart switches, RS-485 repeaters, and other off-the-shelf products. These devices are commonly used to link programmable logic controllers (PLC), supervisory control and data acquisition (SCADA) systems, remote terminal units (RTU) and other equipment in custom networked systems.

The EIA/TIA-422 and EIA/TIA-485 standards do not define protocols. They are simply physical layer standards (and even then, do not specify connectors or pin-outs). This means that RS-422 and RS-485 can be implemented in many systems and applications. Often the standards are used to extend serial links, or to network equipment that was not previously interconnected. Systems using the ubiquitous MODBUS protocol are often interconnected using RS-485 multidrop networks.

Data Transmission Signals

There are several inescapable facts about data communications signals that must be considered in any data communications system. Data, in the form of electromagnetic signals, must be created, sent along some kind of medium (which travels through a variety of environments) and detected at its destination. For the purposes of this document the signal is digital pulses and the medium is wire pairs.

Digital pulses are voltages that represent binary states - ones and zeros. Voltages change from state to state, which creates rising and falling edges. The number of pulses per second (baud rate) determines how much data can be sent in a given period. The transmitters, media and receivers must be able to create, transfer and detect the pulses reliably at the baud rate at which the system is operating. The noise picked up in transit can affect the receiver's ability to reliably detect

real data. Characteristics such as the bandwidth and amount of attenuation in the media, the amount and type of noise, and the sensitivity of the receiver to the signal and noise, affect the maximum possible data rate and transmission distance.

Unbalanced Data Transmission

To understand the advantages of balanced data transmission used in RS-422 and RS-485 systems it is helpful to review the characteristics and features of unbalanced data transmission.

RS-232 is an unbalanced transmission standard. Each signal that transmits in an RS-232 system appears on the interface connector as a voltage with reference to a signal ground. For example, the transmitted data from a DTE device appears on TD with respect to GND. (When using the connector specified in the EIA-232 standard (DB-25) these signals are found on pin 2 and pin 7 respectively.)

When the TD line is in the idle state (not transmitting), this voltage is negative (representing a logic 1 or mark). A logic 0 or space is represented by a positive voltage. When transmitting data the voltage alternates between that negative level and a positive level. Typically data pulses are transmitted with a magnitude somewhere between ± 5 and ± 15 volts. Although the EIA-232 standard allows a range of ± 3 volts to ± 25 volts, an RS-232 receiver typically operates within the voltage range of ± 3 volts and ± 12 volts.

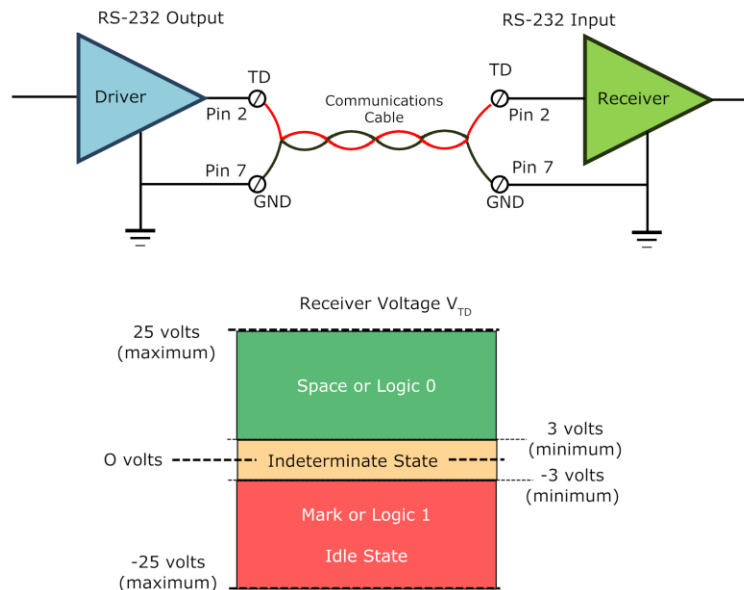

Figure 3: RS-232 Transmission Signals

Unbalanced data transmission works well over short distances, at limited baud rates, especially in low noise environments. Unfortunately, unbalanced systems allow capacitively and inductively coupled noise to be superimposed onto the signal (TD) line. If the noise attains levels that compete with the data signal, errors will occur. In environments where electrical noise is prevalent, RS-232 should only be used over short distances at lower baud rates. The EIA-232 standard limits cable length to 50 feet and bit rates to 20 kbps (although in ideal situations these limits can be exceeded).

Note: RS-423 also uses unbalanced data transmission. For information on RS-423 refer to EIA Standard RS-423 Data Transmission (on page 89).

Balanced Data Transmission

In a balanced data transmission system the voltage produced by the driver appears across a pair of signal lines. These lines produce complementary (opposite) output signals. When one is low, the other is high, and vice versa. It is important to understand that RS-422/RS-485 balanced data transmission also requires a GND connection, even though the GND connection is not used by the receiver to determine the logic state of the data.

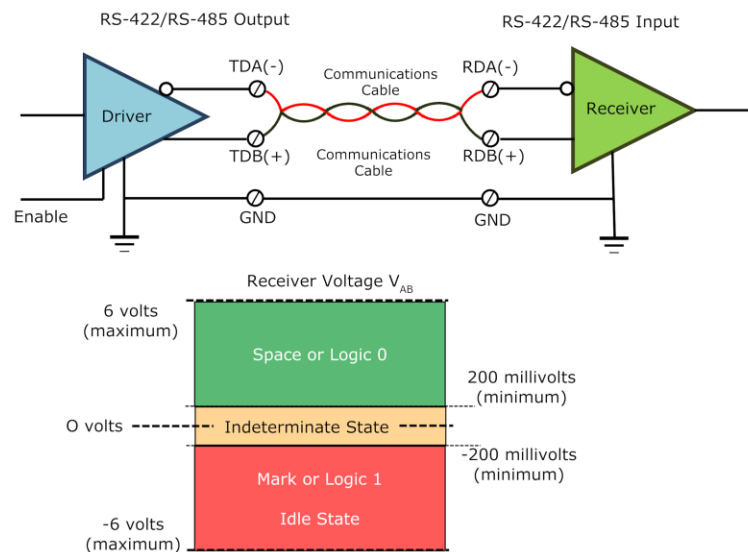

Figure 4: RS-422/RS-485 Balanced Data Transmission

When the driver output voltage is measured differentially, the voltage on the A (-) terminal with respect to the voltage on the B (+) terminal is negative when in the idle state. Typically this voltage is expressed as V_{AB} . RS-422 and RS-485 drivers produce a voltage somewhere between 2 to 6 volts across their A (-) and B (+) output terminals. The exact value may vary depending on the power supply voltage, number of unit loads (UL) connected to the output and termination/biasing arrangement. For more information on termination and biasing refer to System Configuration (on page 23).

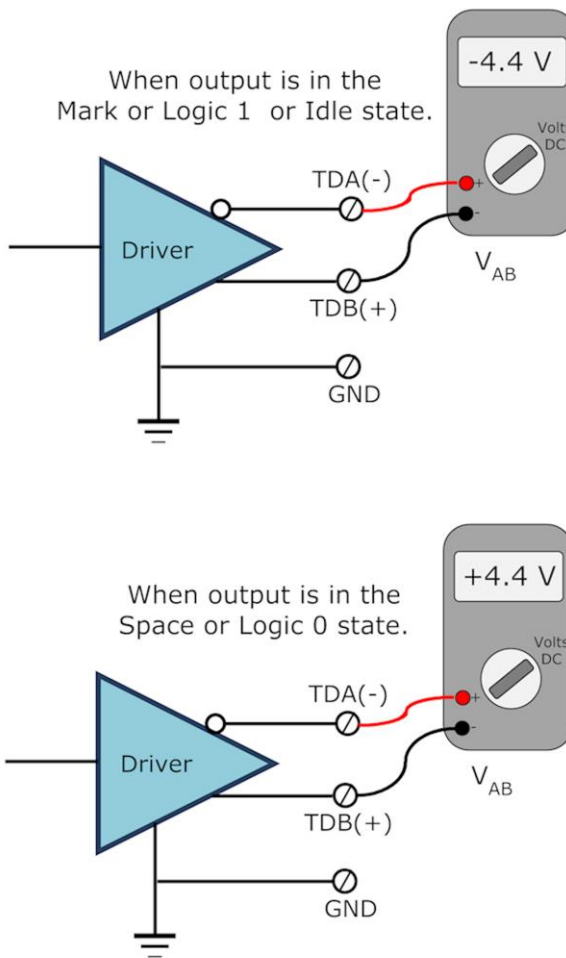

Figure 5: Measuring Balanced Outputs

Note: If all RS-485 drivers on a communications line are tri-stated (high impedance), the outputs are floating and will not measure the voltage shown.

Balanced differential line receivers sense the voltage state of the transmission line across the two signal input lines, A (-) and B (+). When V_{AB} is between -200 mV and -6 volts the receiver interprets the signal as a logic 1 or mark. When V_{AB} is between +200 mV and +6 volts the receiver interprets the signal as a logic 0 or space.

RS-422 and RS-485 Terminals and Designations

There are a number of different RS-485 devices used in RS-485 communications systems. Some have their transmitter and receiver data lines available separately, enabling them to be used in RS-422 or RS-485 four-wire systems. Others internally bridge the driver and receiver data lines so that they can only be used in two-wire mode. Still others can be user-configured for two- or four-wire operation using switches, jumpers or external wiring.

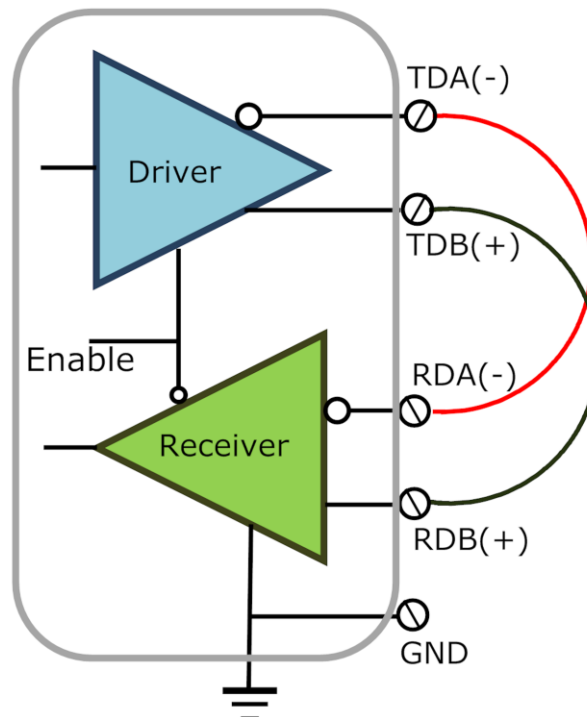

Figure 6: RS-485 Chip with TD and RD pins available

Some transceiver chips are manufactured with their driver and receiver data lines connected internally, permanently configuring them as two-wire devices.

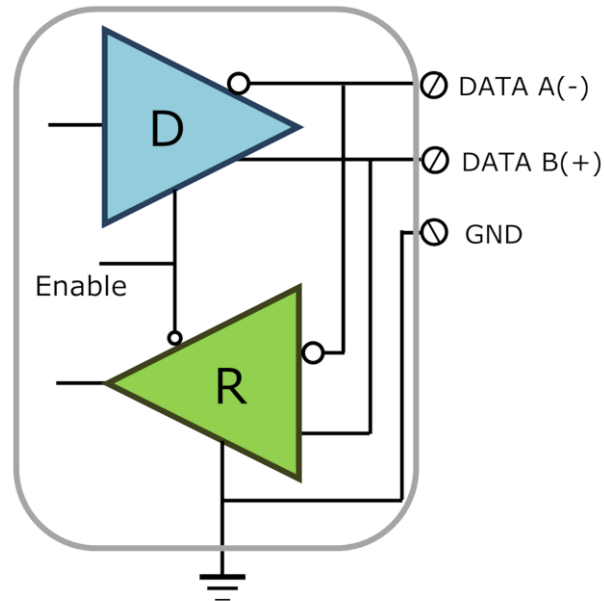

Figure 7: RS-485 Chip with internal bridging

The EIA-485 specification labels the data lines A and B. Some manufacturers label two-wire systems DATA A and DATA B and four-wire systems TDA, TDB, RDA and RDB. Other manufacturers simply label them "-" and "+". (In this document, and on B+B SmartWorx equipment, two-wire systems are labeled DATA A(-) and DATA B(+), and four-wire systems are labeled TDA(-), TDB(+), RDA(-) and RDB(+).) Although it is impossible to predict how other manufacturers will label these lines, practical experience suggests that the "-" line should be connected to the A terminal and the "+" line should be connected to the B terminal. Reversing the polarity will not damage an RS-485 device, but it will not communicate.

Common Mode Voltage

One of the reasons that balanced data transmission is superior to unbalanced is that most noise picked up by the communication line is

coupled equally to both signal lines, TDA(-) and TDB(+). At the receiver any signal that occurs equally on both signal lines is subtracted by the differential inputs. This effectively eliminates noise common to both inputs, leaving the communications signal, which can then be detected and recovered.

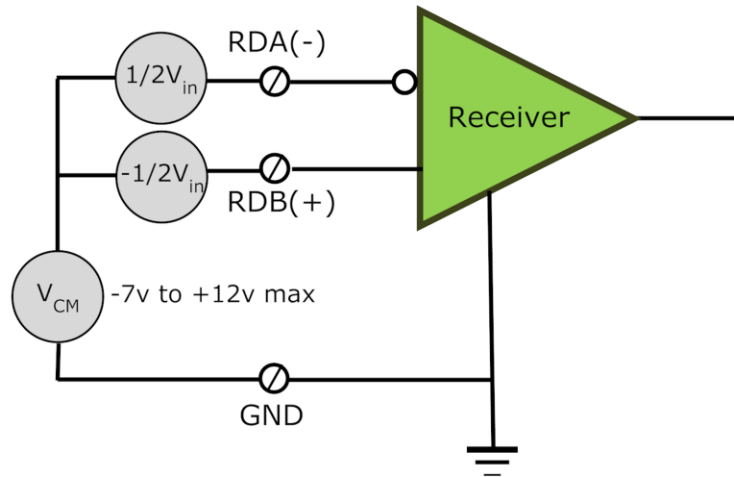

Figure 8: Common Mode Voltage on Differential Inputs

However, differences in ground potential (including steady state voltages and transients created by ground currents) between the transmitter and receiver can create common mode voltages that exceed the specifications of the receiver's inputs. Exceeding the V_{CM} voltage specification of the device can cause loss of data and even damage to the component itself.

The specifications for most RS-422 and RS-485 devices indicate that the device can withstand a maximum V_{CM} of -7 volts to +12 volts. The function of the GND connection is to tie the signal grounds of all nodes on a network to one common ground potential. This ensures that the common mode voltage cannot exceed the specified value.

Depending on the application, several different techniques are used to ensure common mode voltages do not exceed these specifications. Refer to [Transient Protection of RS-422 and RS-485 Systems](#) (on page 49).

Tri-State Control

One important feature of RS-485 systems is the ability to multidrop network nodes. To do so the outputs of all RS-485 drivers not currently transmitting must be effectively disconnected from the transmission line. Without this feature, drivers (which are typically in the idle state when not transmitting), would hold a negative voltage (logic 1 or mark) on the transmission line. If another driver connected to the same transmission line started sending data, it would not be able to pull the line into the logic 0 state. This is called bus contention.

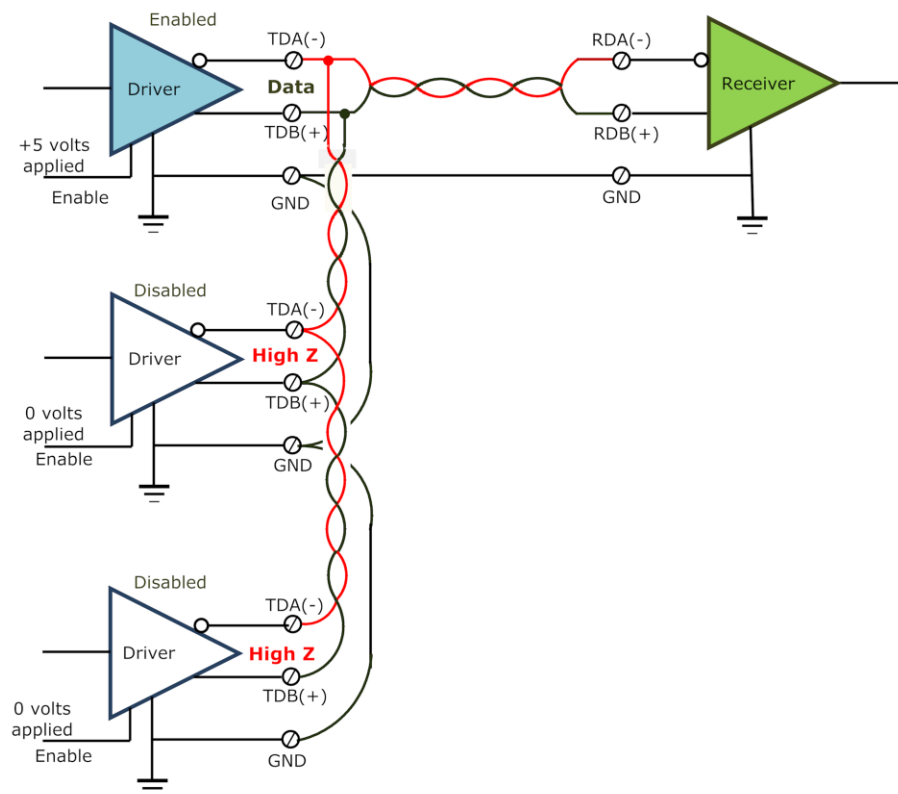

Figure 9: Tri-State Control

To facilitate multiple drivers on one transmission line, RS-485 balanced line drivers have an enable input. By controlling the enable input the driver can be effectively disconnected from the transmission line. In the disconnected state the output becomes a high impedance to the line and will not affect the state of the line at all. This effectively adds a

third state to the driver output. Because of the three states (logic 0, logic 1 and high impedance) the device output is called a tri-state output. When in the high impedance state the output is sometimes referred to as "tri-stated". In typical systems, control of the driver's enable input is accomplished using RTS Control (on page 17) or Send Data Control (on page 18).

RTS Control

One common application of RS-485 in a communication system is the connection of several devices that have standard RS-232 serial interfaces, to create a network. This typically requires conversion to RS-485 using an RS-232 to RS-485 converter or an RS-485 serial card.

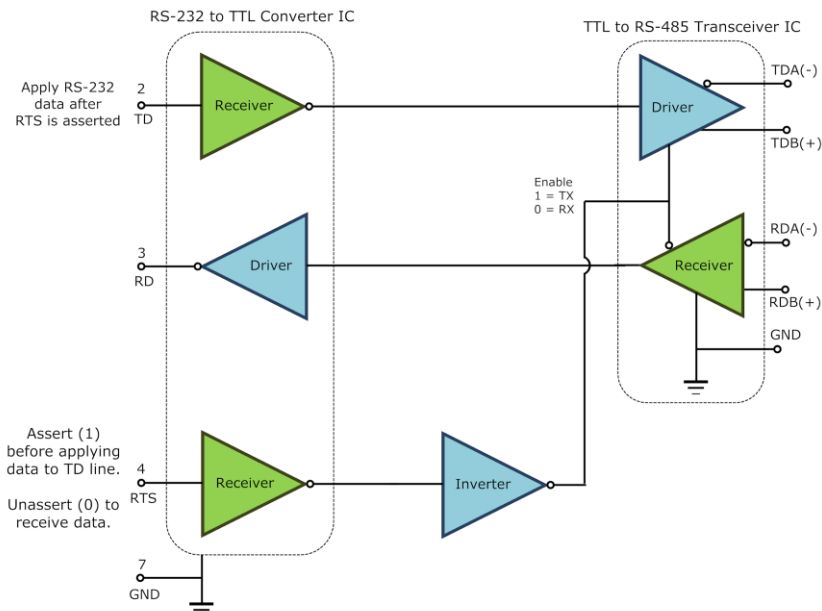

Figure 10: RTS Control

This may be implemented using the RTS control signal from an asynchronous serial port to enable the RS-485 driver. The RTS line is connected to the RS-485 driver enable such that setting the RTS line to a high (logic 1) state enables the RS-485 driver. Setting the RTS line low (logic 0) puts the driver output into the high impedance condition. This in effect disconnects the driver from the bus, allowing other nodes to transmit over the same wire pair.

Control of the RTS line must be set up in the communications software controlling the serial port, to ensure that the RTS line is asserted before data is applied to the TD line. The RTS line must be unasserted (released) after the last data bit is sent. This not only decouples the driver from the network, but also enables the receiver to accept incoming data put on the communications line by other nodes on the network.

RTS control is not usually suitable for Windows systems because RTS timing cannot be closely controlled, which can result in lost data. For additional details refer to [RTS Control Timing Diagrams](#) (on page 95).

If the RS-485 transceiver is connected to a two-wire multidrop network, and if the RS-232 to RS-485 converter can be configured to keep the receiver enabled all the time, the receiver will receive an "echo" of the data transmitted by the driver. This is desirable in some systems, and troublesome in others. Be sure to check the data sheet for your converter to determine how the receiver "enable" function is connected.

Send Data Control

Send Data control automates the process of enabling an RS-485 transceiver, removing the need to assert a hardware handshake line each time data is transmitted. The RS-485 driver is enabled as soon as data is detected at the input and disabled one character length after the data stops.

One technique for accomplishing this is to use a retriggerable timing circuit, as shown in the following diagram.

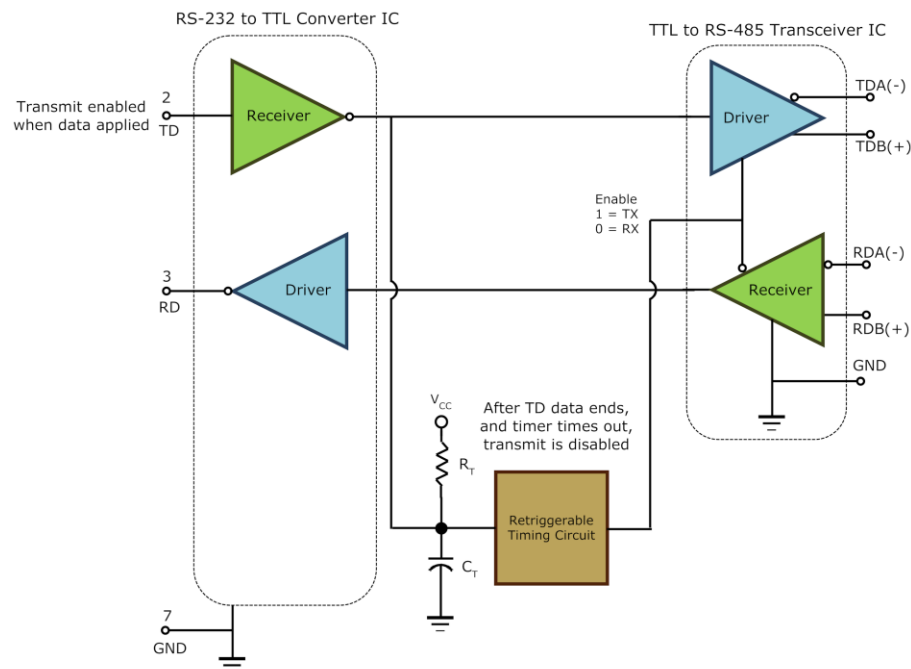

Figure 11: Send Data Control

The timing circuit uses a resistor and capacitor to set the retriggering time constant. The circuit enables the driver when it detects the leading edge of the first data pulse. As long as data is being received by the converter the timing circuit is continuously retriggered, maintaining the enable signal to the RS-485 driver. When the data stops (and the data signal returns to the idle state) the timing circuit releases (disables) the driver after a configurable period of time, typically one character length (ten bit lengths).

Since the length of time required for one character varies depending on the baud rate of the system, the time period of the timing circuit must be configurable. When using a retriggerable time circuit the timing circuit can be configured by changing the R and/or C values.

Some RS-485 devices come from the factory with R/C values preset for 9600 baud. Others have switch selectable presets.

Care must be taken when setting the period of the timing circuit. If the time is too short, it could time out before the entire character has been transmitted, which would result in retries (the system would repeatedly try to re-send the message). If the time is too long, the start of the data from the last node polled could be lost. (In a master/slave system the master requests data, so no other node should be sending or replying other than the one addressed by the master.)

For additional details refer to [Send Data Control Timing Diagrams](#) (on page 96).

Bit-wise Enable Timing Control

Some RS-485 devices use bit-wise enable timing for tri-state control. In this method, the RS-485 driver is enabled each time the RS-232 TD line is in the space state. When the RS-232 TD data goes from space to mark, the RS-485 driver is driven back to the mark state and then released. The biasing resistors ensure that the output lines remain in the mark state. On each change from a space to a mark this occurs. (It is important that clear leading and trailing edges are created on the output of the driver because these are used to determine the center of each bit.)

NOTE: For a more complete explanation of biasing refer to [Biasing an RS-485 Network](#) (p. 32).

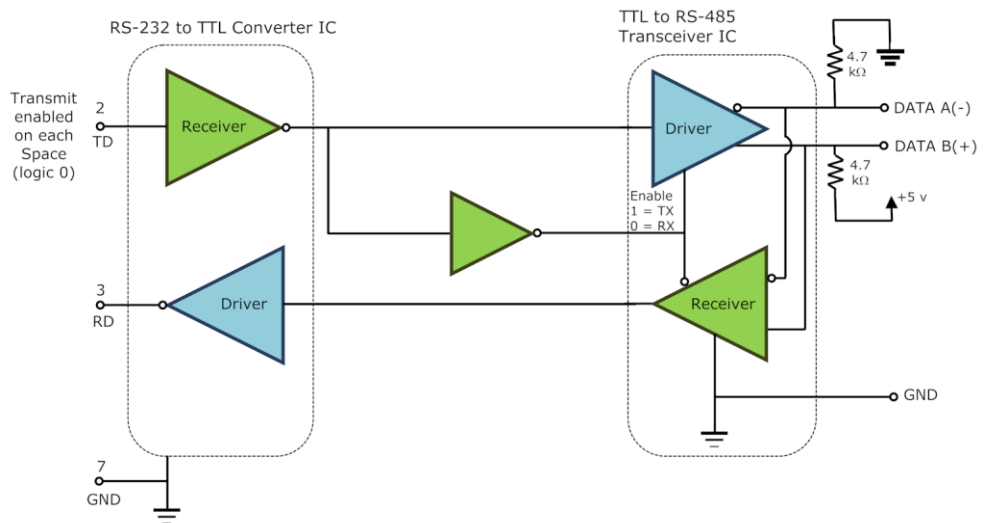

Figure 12: Bit-Wise Enable Timing

For additional details refer to [Bit-wise Enable Timing Diagrams](#) (on page 97).

Other Tri-State Control Techniques

Some RS-485 devices use bit counters or a UART Transmit buffer status line for control.

Bit counters monitor the number of bits in a message and enable the RS-485 driver while data bits are being sent, counting the number of bits sent and disabling the driver when the total number is reached.

The UART transmit buffer status technique uses a signal that is part of the UART circuitry. When data to be sent is detected the UART control line enables the RS-485 driver. The UART's transmit buffer stores data as it is received, and sends it to the RS-485 driver. When the buffer is empty the UART disables the driver.

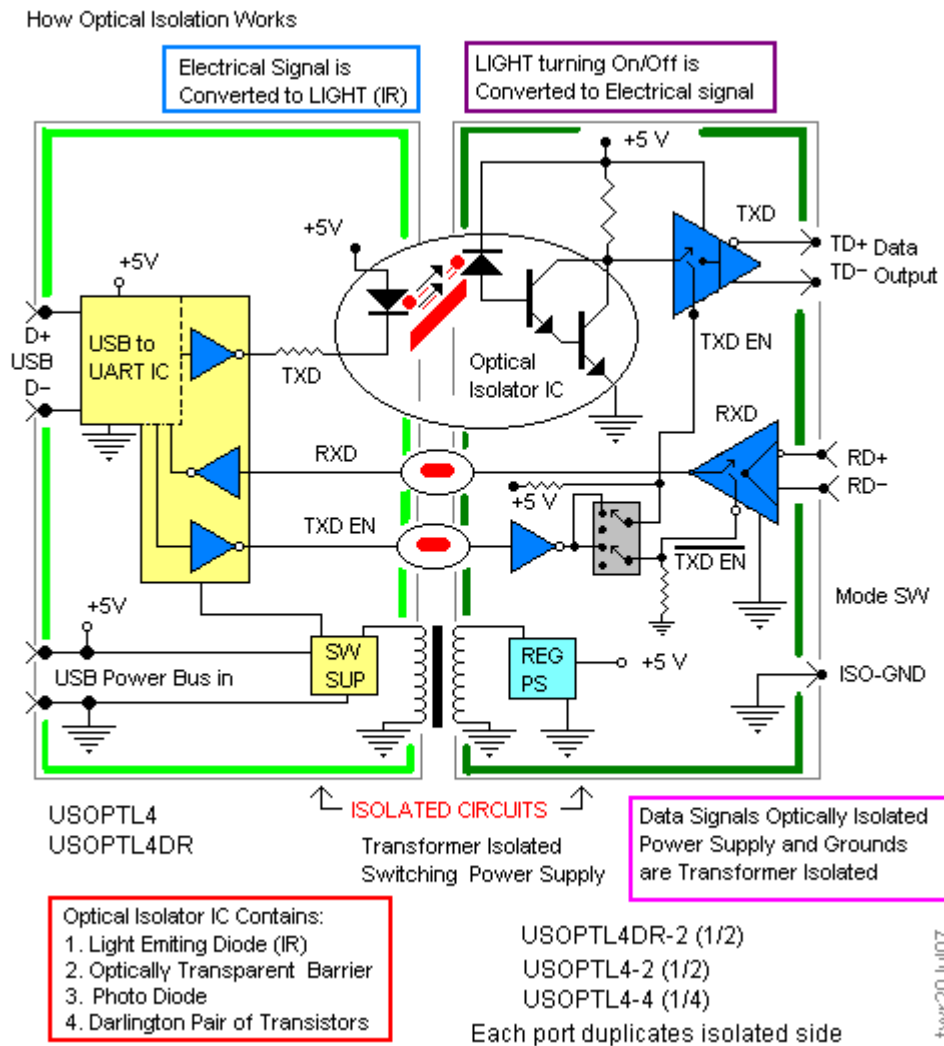

Figure 13: UART Control

CHAPTER 2

System Configuration

RS-422 and RS-485 systems can be configured in a variety of ways to provide a wide range of communications solutions. This section includes information on connections and topologies, two and four-wire systems, termination and biasing issues and solutions, and the application of repeaters.

In This Chapter

RS-422 Point-to-Point Connections.....	24
Network Topologies.....	25
Two-Wire Systems	25
Four-Wire Systems	27
Termination	27
Biasing an RS-485 Network	32
Other Biasing and Terminating Considerations.....	38
Using Repeaters.....	39
Using Fractional Load Receivers to Extend Distance and Number of Nodes.....	42

RS-422 Point-to-Point Connections

The most common use for RS-422 devices is in point-to-point serial links where other interface standards such as RS-232 do not provide adequate distance or speed. If the link is simplex (single direction of data flow) a RS-422 system requires a pair of wires for TDA(-) and TDB(+) and a ground.

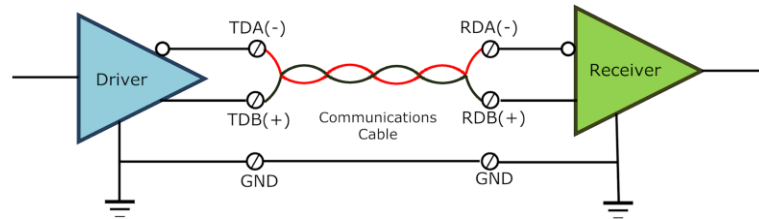

Figure 14: RS-422 Point-to-Point Connection

For duplex communication a separate driver and receiver must be used at both ends. Each direction requires twisted pair for communications but one signal ground can be used for both.

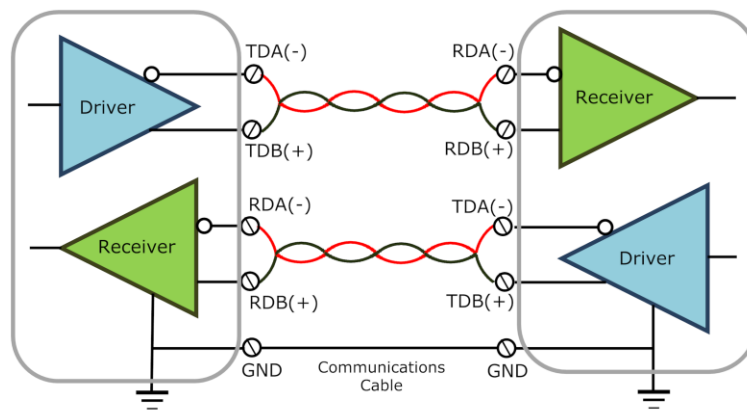

Figure 15: RS-422 Four-Wire Full Duplex Connection

If RS-422 is being used to extend the distance or speed of an interface such as RS-232, which may implement several handshake lines, additional driver/receiver combinations are needed, as well as a dedicated pair of wires for each signal.

Network Topologies

The topology of a network describes the physical or logical configuration of the nodes on the network. The EIA standards do not define network topologies for RS-422 and RS-485. A variety of topologies can be used, although in practice some topologies work better than others, for reasons explained in the following sections.

RS-485 two and four-wire networks can be connected in a variety of topologies (bus, ring, star, tree, etc), especially when baud rates are relatively low, distances are short and noise is limited. However, for simplicity and reliable results many experienced users suggest using a daisy chain network configuration. However, the physical requirements of the application may dictate other connections and layouts.

RS-422 is most commonly used in point-to-point links. But when RS-422 is used in point-to-multipoint connections, or when RS-422 is used as the master in a four-wire master-slave network, the same network topology considerations apply.

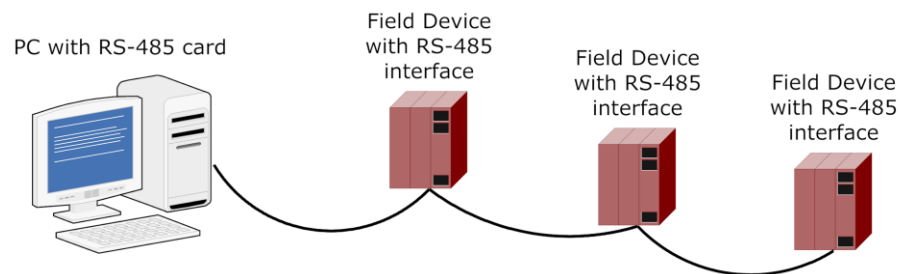

Figure 16: Daisy Chain Network Topology

Note: The Methods of Termination (on page 29) section discusses how network topology relates to the placement of termination resistors.

Two-Wire Systems

The tristate capabilities of RS-485 allow a single pair of wires to share transmit and receive signals for half-duplex communications. Although this is commonly referred to as a "two-wire" configuration, an

additional ground conductor should be used to tie the signal grounds together.

Note: RS-422/485 systems may communicate successfully without the signal ground when nodes are located close together and circuit grounds for all nodes are at the same potential--e.g., a controlled lab environment. However, this practice is not recommended. If a signal ground is not used when nodes are separated by distance, and there is the possibility of lightning and/or other electrical noise, the common mode voltage can rise to levels that could compromise communications, or even damage the transceivers in the system nodes.

Two wire systems operate in half-duplex, "taking turns" using the media to alternately transmit and receive data. A protocol, implemented by the system software, determines which node(s) initiate communications, and how other nodes respond. Often, RS-485 networks use simple master-slave protocols such as Modbus. For more detail refer to [Software](#) (on page 65).

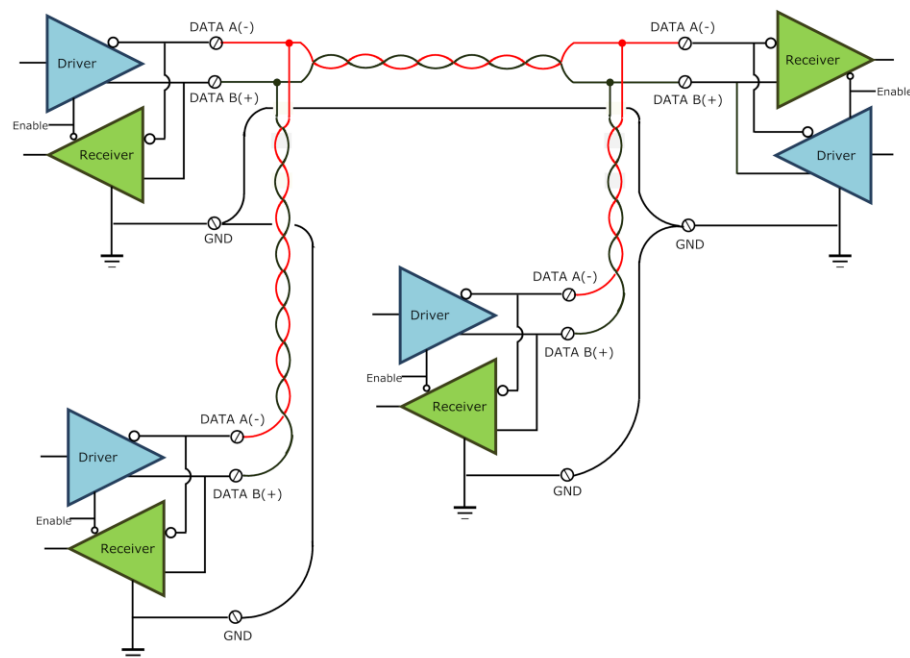

Figure 17: RS-485 Multidrop Network

Four-Wire Systems

Like two-wire systems, the name "four-wire" system is something of a misnomer. Four-wire systems should use five conductors for reliable operation in all situations.

Typically, four-wire systems implement a master-slave protocol in which the driver of the master is connected by one twisted pair to the receivers of all slaves. Another twisted pair connects the drivers of all slaves to the receiver in the master. The fifth conductor is the signal common, which connects to all nodes, ensuring that V_{CM} is limited within a safe range.

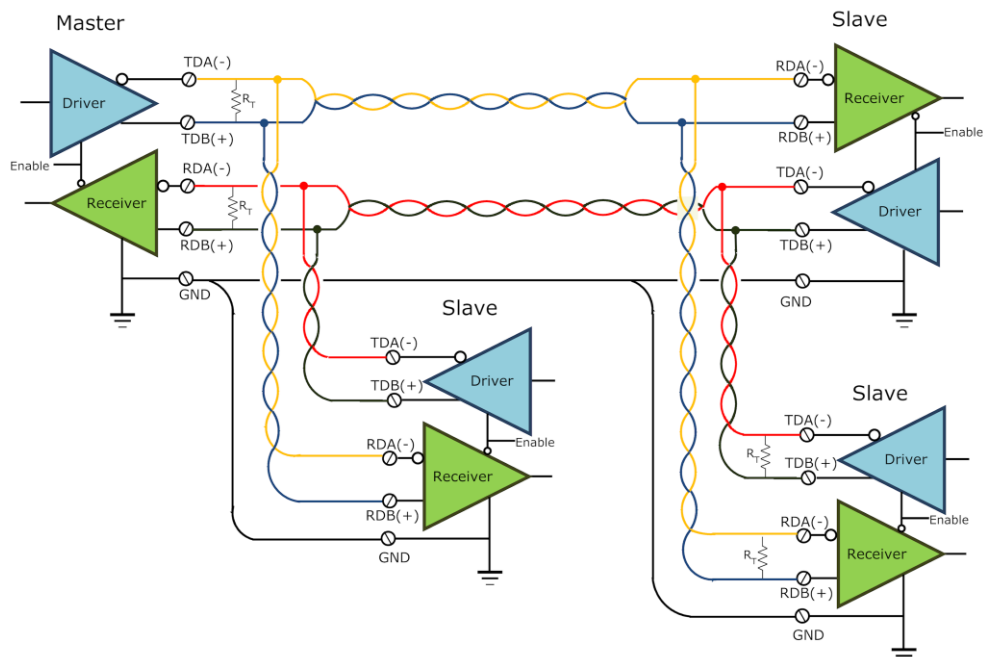

Figure 18: RS-485 Four-Wire Configuration

Termination

Termination is used to match the impedance of a communications node to the impedance of the transmission line being used. Data signals travel as a wave along the transmission line at a speed somewhat less than the speed of light. When the wave reaches the end of the

transmission line, if the line is not terminated with an impedance equal to the line impedance, the transmitted signal is not completely absorbed and a portion is reflected back into the transmission line. Reflections interfere with real data and can cause errors. If the source, transmission line and load impedances are equal, reflections are eliminated.

A practical solution is to add a resistor in parallel with the receiver's A and B lines in order to match the characteristic impedance of the communications cable. This value is specified by the cable manufacturer. (120 ohms is a common value.) This value describes the intrinsic impedance of the transmission line and is not a function of the line length. A terminating resistor of less than 90 ohms should not be used.

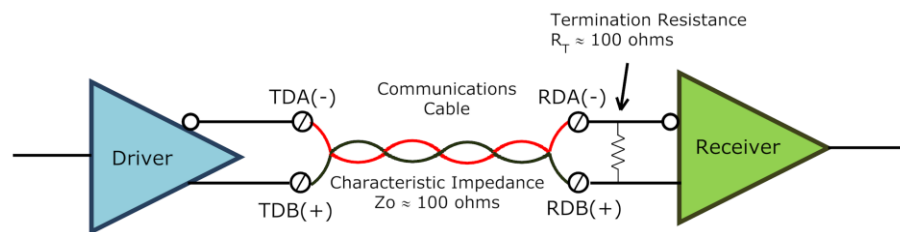

Figure 19: Transmission line with termination

Deciding whether to use termination

Although termination may be necessary in some situations, there are also disadvantages to implementing termination. Termination increases load on the drivers, increases installation complexity, changes biasing requirements and makes system modification more difficult.

Note: If termination is added, and its effects on biasing are not considered, it can compromise the performance of the communications system.

The decision whether or not to use termination should be based on the cable length and data rate used by the system. A good rule of thumb is if the propagation delay of the data line is much less than one bit width, termination is not needed. This rule makes the assumption that reflections will damp out in several trips up and down the data line.

Since the receiving UART will sample the data in the middle of the bit, it is important that the signal level be solid at that point.

One practical rule of thumb suggests that, for equipment operating data rates less than 38.4 kbps, termination is usually unnecessary.

Example calculation to determine whether termination is necessary

In a system with 2000 feet of data line the propagation delay can be calculated by multiplying the cable length by the propagation velocity of the cable. This value, typically 66 to 75% of the speed of light (c), is specified by the cable manufacturer. A round trip covers 4000 feet of cable. Using a propagation velocity of $0.66 \times c$, one round trip is completed in approximately $6.2 \mu\text{s}$. Assuming the reflections will damp out in three "round trips" up and down the cable length, the signal will stabilize $18.6 \mu\text{s}$ after the leading edge of a bit. At 9600 baud one bit is $104 \mu\text{s}$ wide. Since the reflections are damped out much before the center of the bit, termination is not required.

Methods of Termination

There are several methods of terminating data lines. These include parallel termination, bidirectional termination and AC termination.

Parallel Termination

Parallel termination is the addition of a single termination resistor somewhere along the communications line. Ideally termination resistance should be added at the point on the communications line furthest from the driver sending the signal. This works best on a point-to-point link, or an RS-422 four-wire communications system in which a driver at one end sends to a receiver at the other. The value of the termination resistance should be close to the specified characteristic impedance of the cable.

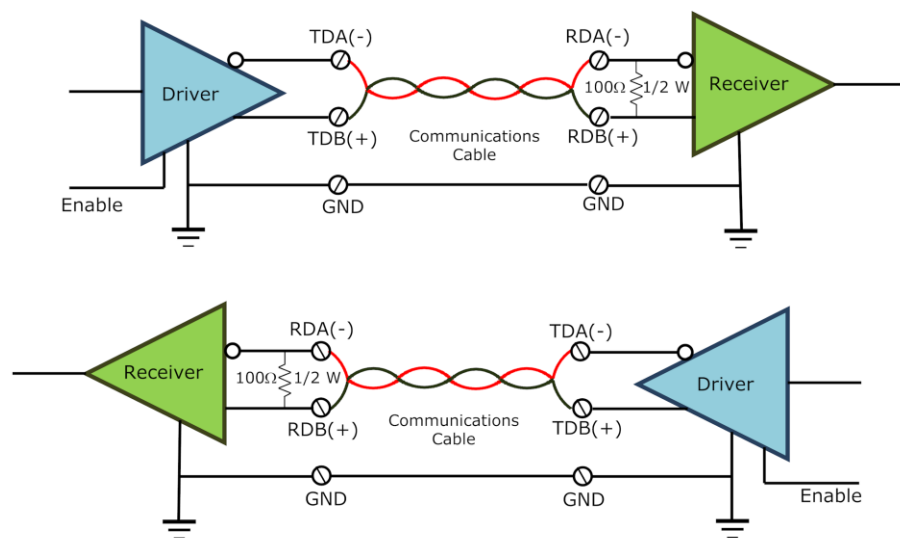

Figure 20: Terminating Point-to-Point Connections

More complex network topologies, such as star and tree, make it more difficult to determine where the extremities of the network are and, hence, the best location for termination. Also, unterminated network stubs--especially longer ones--can add reflections that may compromise network communications.

Bidirectional Termination

Bidirectional termination is dividing the termination resistance into two parts and placing them (preferably) at the extreme ends of the communications line. This is recommended when operating a two-wire multidrop bus because data travels in both directions.

No more than two terminations should be placed in any system that does not use repeaters.

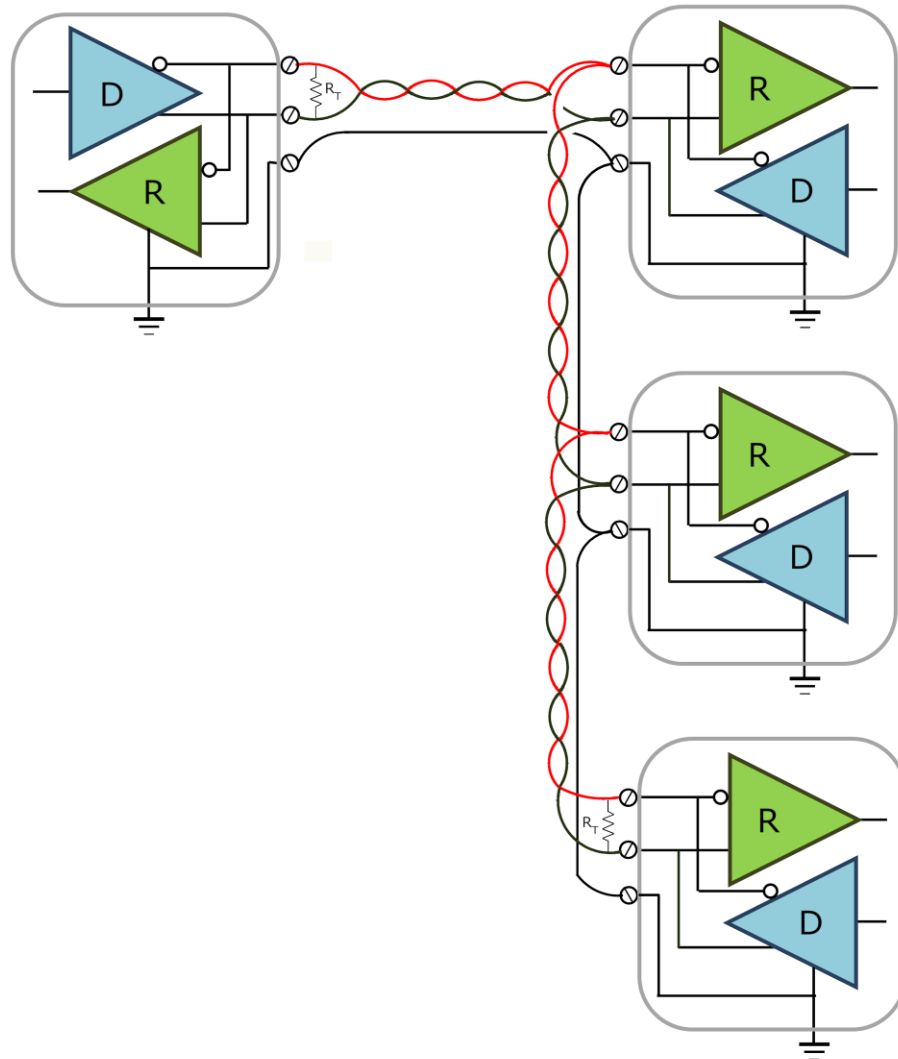

Figure 21: Two-Wire Multidrop Network

The risk of using bidirectional termination is that it adds heavy DC loading to the system. Port powered RS-232 to RS-485 converters may be overloaded by the use of bidirectional termination.

Daisy-chain topology has advantages for bidirectional termination: the furthest ends of the network are relatively simple to determine.

AC Termination

AC coupled termination adds a small capacitor in series with the termination resistor to eliminate the DC loading effect, which affects biasing. Although this method eliminates DC loading, capacitor selection is highly dependent on the system properties. System designers interested in AC termination are encouraged to read National Semiconductors Application Note 903 (note 2) for further information.

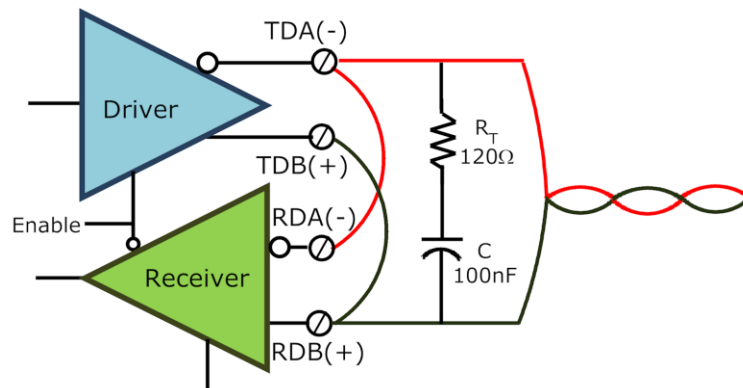

Figure 22: AC Termination

Termination to Reduce Noise

In some instances where termination would not otherwise be needed, if noise pickup on the communications line is a problem, it may still be necessary to add a termination resistor. In this case adding a termination resistor with a value larger than the line impedance—for example 1 kΩ—may reduce noise while still maintaining a usable bias voltage. The primary consideration is that at least 300 mV should be maintained across the signal lines while the line is idle.

Biasing an RS-485 Network

When an RS-485 network is idle (no data being transmitted) all RS-485 drivers are inactive, in the high impedance state (tri-stated). Receivers are enabled, listening for the next data message. During this time the communications line should be in the idle state (mark, logic 1, $V_{AB} > -200$

mV) so that when a driver does start sending serial data the start bit transition (from logic 1 to logic 0) can be detected.

However, since all drivers are tri-stated nothing is holding the communication line in the idle state. Without anything driving the network, the state of the line is unknown--essentially floating. If V_{AB} is less than -200 mV the logic level is indeterminate (and internally, at the output of the receivers will typically be the value of the last bit received).

In order to maintain the proper idle state, bias resistors must be included in the communications outputs to force the data lines to the idle state voltage. Bias resistors are nothing more than a pull-up resistor on the DATA B(+) line (typically to 5 volts) and a pull-down resistor (to ground) on the DATA A(-) line. The following diagram illustrates how bias resistors are connected on a transceiver in a two-wire configuration.

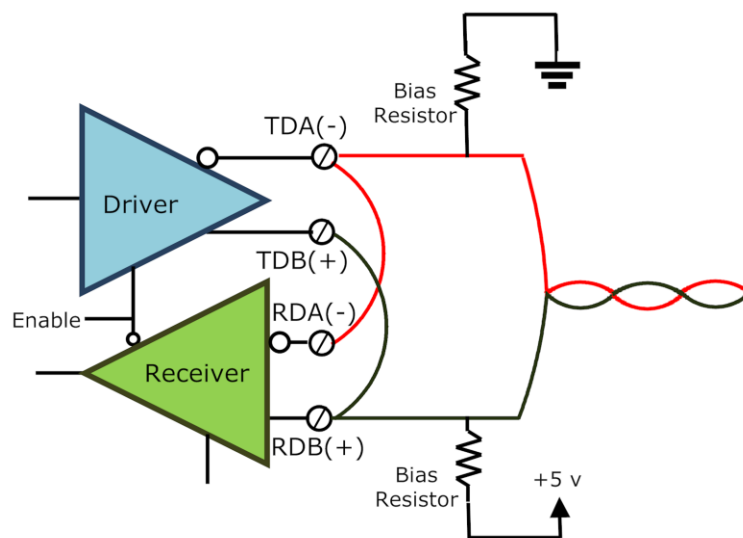

Figure 23: Bias Resistors

The value of the required bias resistance is dependent on termination resistance in a system and number of nodes connected. The goal is to generate enough DC bias current in the network to maintain a voltage across the data lines (when no drivers are enabled) that will be interpreted as a mark or logic 1 state. The EIA/TIA-485 standard

specifies that a mark is considered anything greater than -200 mV (V_{AB}). To ensure reliable operation B+B SmartWorx typically suggests that you design for approximately -300 mV.

Bias resistors can be placed anywhere in the network, or can be split among multiple nodes. The actual bias resistance is the parallel combination of all bias resistors in a system.

Equivalent parallel resistance is calculated using the following formulae:

For 2 parallel resistors:

$$R_T = \frac{(R_1 \times R_2)}{(R_1 + R_2)}$$

For multiple parallel resistors:

$$\frac{1}{R_T} = \frac{1}{R_1} + \frac{1}{R_2} + \frac{1}{R_3} + \dots$$

Example 1: Biasing when termination resistors are used

In this example, ten RS-485 transceiver nodes are connected together on a daisy-chain network. Two 120 Ω termination resistors are connected -- one at each end of the network. Each node includes two built-in 4.7 k Ω biasing resistors, a pull-up and a pull-down.

Question: Will this arrangement reliably maintain the idle state when all drivers are tri-stated?

RS-485 nodes are specified to present a load impedance of 12 k Ω . Ten nodes in parallel present a total load of 1200 Ω . The two 120 Ω termination resistors present an additional 60 Ω load (in parallel). The result is a total load across the signal lines of 57 Ω .

Ten nodes, each with 4.7 k Ω biasing (pull-up and pull-down) resistors, produce equivalent biasing resistances of 470 Ω pull-up and 470 Ω pull-down. The total resistance from 5V to ground is 470 Ω + 57 Ω + 470 Ω = 997 Ω .

Current through the voltage divider is approximately 5 mA.

The voltage across the signal lines (V_{AB}) is -285 mV. Although slightly less than the goal of -300 mV, this is acceptable for idle state biasing.

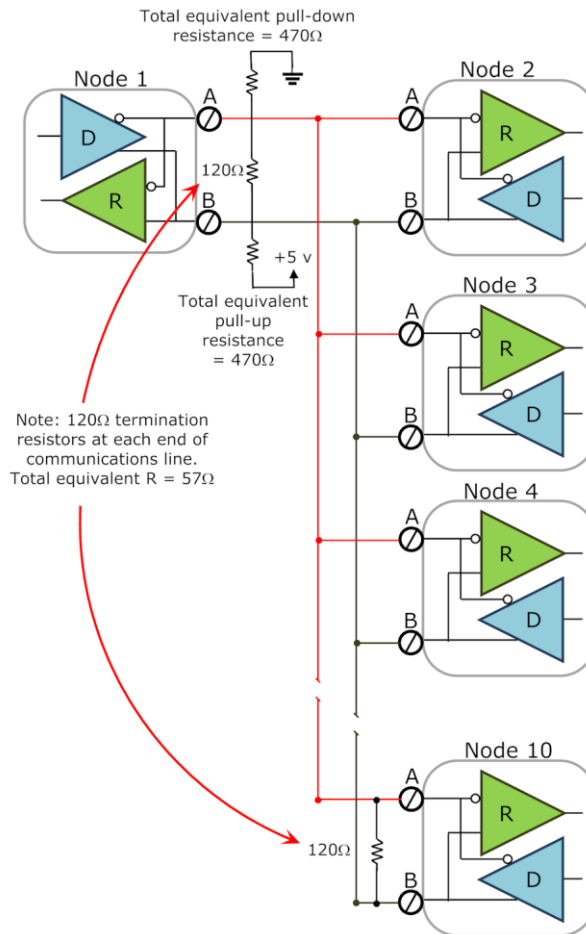

Figure 24: 10 Node RS-485 Network with two 120 ohm termination resistors

Notice that the current is relatively high and the termination resistors are responsible for a majority of the loading. Adding nodes with built-in biasing resistors would increase the minimum idle state voltage but would further increase the current. Decreasing nodes would eventually result in insufficient idle state voltage. Ultimately, the example shows that the combined effects of termination and idle state biasing must be calculated and biasing resistance adjusted, if necessary to ensure reliable idle state performance.

Example 2: Biasing when termination resistors are not used

In this example, ten RS-485 transceiver nodes are connected together on a daisy-chain network. No termination resistors are connected. Each node includes two built-in 4.7 k Ω biasing resistors, a pull-up and a pull-down.

Question: Will this arrangement reliably maintain the idle state when all drivers are tri-stated?

RS-485 nodes are specified to present a load impedance of 12 k Ω . Ten nodes in parallel present a total load of 1200 Ω .

Ten nodes, each with 4.7 k Ω biasing (pull-up and pull-down) resistors, produce equivalent biasing resistances of 470 Ω pull-up and 470 Ω pull-down. The total resistance from 5V to ground is $470\Omega + 1200\Omega + 470\Omega = 2.24\text{k}\Omega$.

Current through the voltage divider is approximately 2.23 mA. The voltage across the signal lines (V_{AB}) is -2.7 V. This is much more than the target -300 mV, which ensures good idle state biasing.

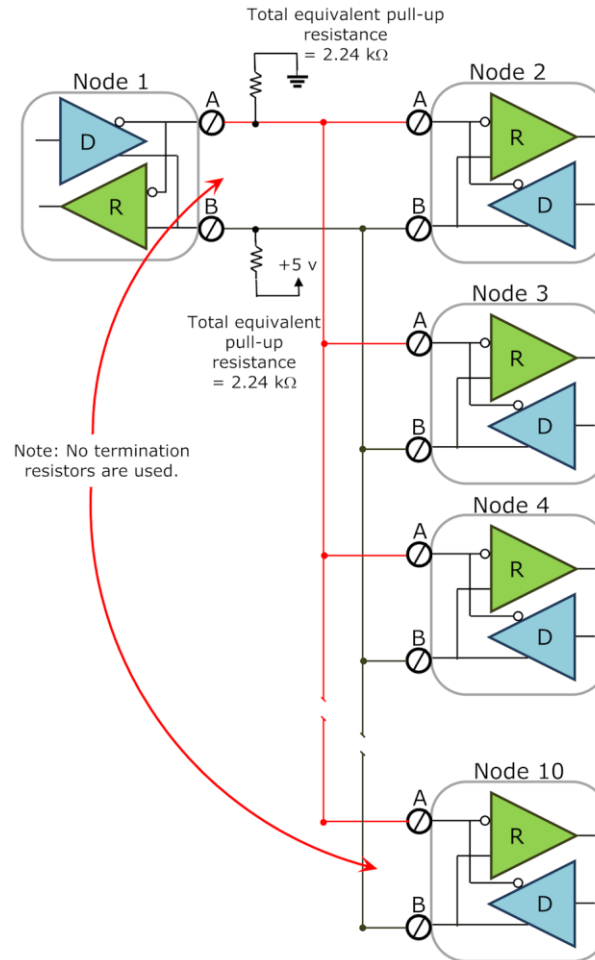

Figure 25: 10 Node RS-485 Network with no termination resistors

Notice that without termination resistors the current requirements are significantly less than when termination resistors are used. In this case adding nodes with built-in biasing resistors does not change the idle state voltage significantly (because the voltage divider scales proportionately), but it does increase the current. Decreasing nodes also does not change the voltage significantly, but does decrease the amount of current required. Ultimately, the example shows that the standard 4.7 kΩ biasing resistors are an appropriate value for most

applications. However, the total current requirement should still be calculated, especially in cases such as when using port-powered converters, which may not be able to supply enough current.

Other Biasing and Terminating Considerations

Standard RS-485 Biasing Resistors. Most B&B RS-485 equipment includes 4.7 k Ω pull-up and pull-down bias resistors from the factory. This value is adequate for most systems without termination. If termination is required it may be necessary to replace these resistors with a different value.

Standard RS-422 Biasing Resistors. Some equipment that is used for four-wire operation uses RS-422 chips. (E.g. B&B 422LCOR) In these devices the included bias resistors are 1K Ω . When RS-422 is used for an RS-485 master node the maximum number of nodes is reduced. A repeater may be needed, especially when termination is used.

The system designer should always calculate the biasing requirements of the network.

Biasing Resistor Locations. In an RS-485 four-wire configuration, the bias resistors are ideally placed on the receiver lines. B+B SmartWorx models that provide two- or four-wire modes of operation (485OPDRI, 485DRCI, and FOSTCDRI) have selectable transmit and receive line biasing resistors. Models such as 4WSD9R, 4WSD9TB, and 485BAT3 have bias resistors on their transmit lines.

Under-biasing. Symptoms of under-biasing range from decreased noise immunity to complete data failure. Over-biasing has less effect on a system, the primary result is increased load on the drivers. Systems using port powered RS-232 to RS-485 converters can be sensitive to over biasing.

Network Biasing. Bias is typically provided on the master node in most networks.

Using Repeaters

In some cases a system requires longer communications lines or more nodes than biasing requirements or the EIA/TIA-485 specifications can accommodate. A common, and effective, solution is to use repeaters. An RS-485 repeater can be placed in a system to divide the load into multiple segments. Each "refreshed" signal is capable of driving another 4000 feet of cable and an additional 31 RS-485 loads.



Figure 26: B&B 485OP Optical Isolated RS-485 Repeater

When using repeaters the Protective Ground connection should always be connected earth ground.

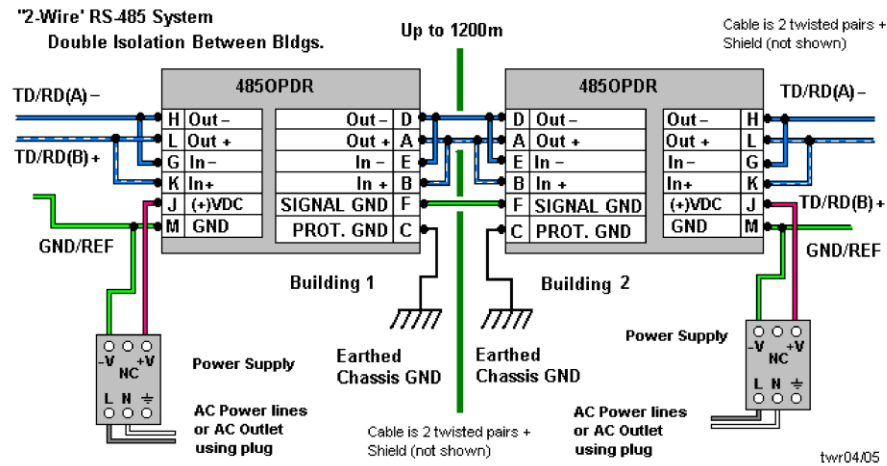

Figure 27: Using Isolated Repeaters

Using Repeaters in a Master-Slave Network

When using repeaters in a master-slave network it can be configured with four-wire on the master side and two-wire on the slave side.

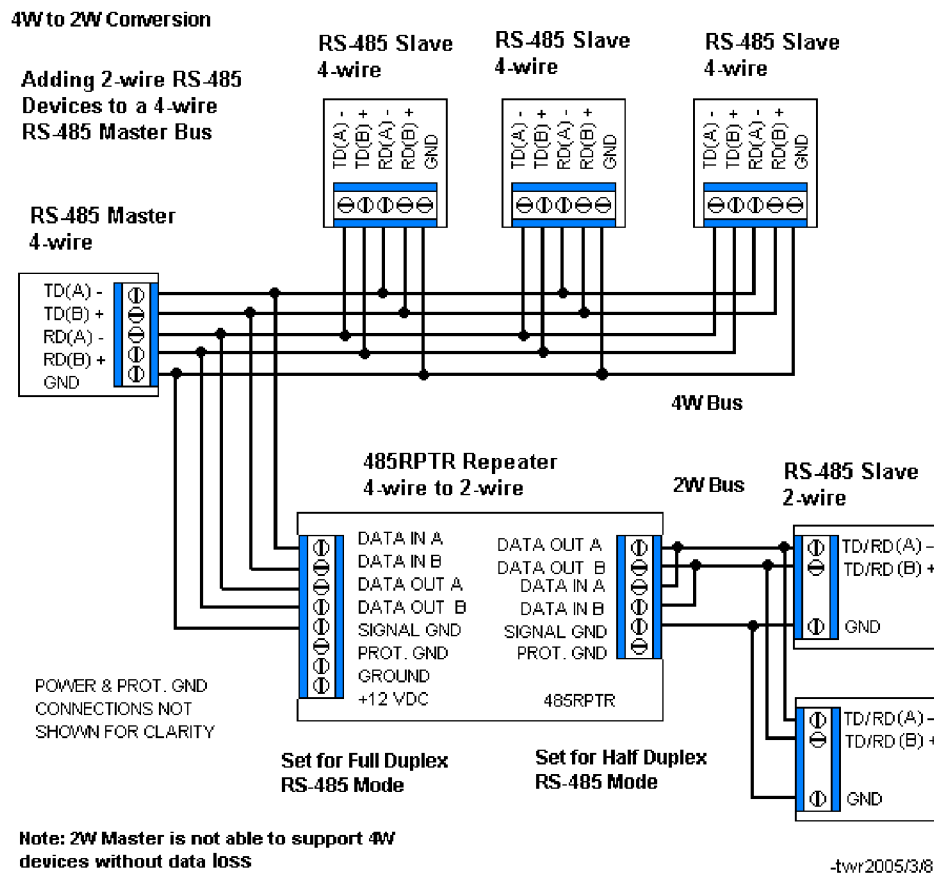

Figure 28: Four-wire to Two-wire Conversion

Typically you cannot have the opposite connection (two-wire master and four-wire slaves) because the slave will usually reply immediately after the end of the master's message, before the master has released its driver. When this happens the beginning of the slave's reply will be lost.

Using Repeaters in Star, Ring and Tree Networks

Repeaters can be used to segment and extend RS-485 networks. As shown in the following diagram, a star configuration can be created by connecting the master node (computer) to several isolated repeaters at a central location. The repeaters connect to nodes on each leg of the star. Each leg can be up to 4000 feet long.

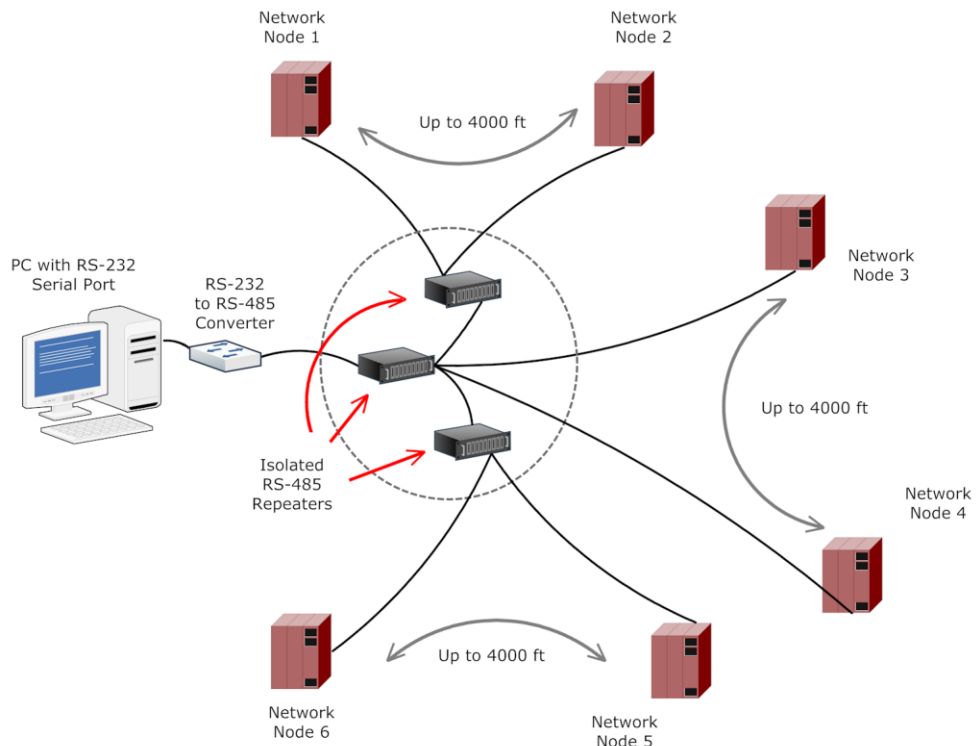

Figure 29: A Star Network using RS-485 Repeaters

Ring networks can be implemented, but they require a special type of repeating device or the data will be repeated around the ring continuously.

Tree and star networks are not recommended unless repeaters are used to segment the sections of the network appropriately.

Using Fractional Load Receivers to Extend Distance and Number of Nodes

Another method of increasing the number of RS-485 nodes is to use low (fractional) unit load type RS-485 receivers. These receivers use a higher input impedance to reduce the load on the RS-485 drivers to increase the total number of nodes. There are currently half, quarter and eighth unit load integrated circuit receivers available, extending the total allowable number of nodes to 64 and 128.

CHAPTER 3

Selecting RS-422 and RS-485 Cabling

Cable selection for RS-422 and RS-485 systems is often neglected. Attention to a few details in the selection process can prevent the costly prospect of re-pulling thousands of feet of cable.

The EIA-422 specification recommends 24 AWG twisted pair cable with a shunt capacitance of 16 pF per foot and 100 ohm characteristic impedance. While the EIA-485 standard does not specify cabling, the EIA-422 specification should be used for RS-485 as well.

In This Chapter

Number of Conductors.....	43
Shielding	44
Cable Characteristics	45
Using Cat 5 for RS-422/485.....	47

Number of Conductors

Describing RS-422/485 communications systems as "two-wire" or "four-wire" is somewhat misleading. To ensure that common mode voltage does not compromise the data, or damage the equipment, an extra wire should always be used to connect the signal grounds. This signal ground conductor is often overlooked when ordering cable. This means that a "two-wire" system actually requires three conductors, and a "four-wire" system requires five conductors.

Although it is possible to obtain cable with a twisted pair and a third conductor, or one with two twisted pairs and a fifth conductor, typically it is simpler just to use a cable with an extra twisted pair and use one

or both conductors for the signal ground. A two-wire system then requires two twisted pairs, and a four-wire system requires three twisted pairs.

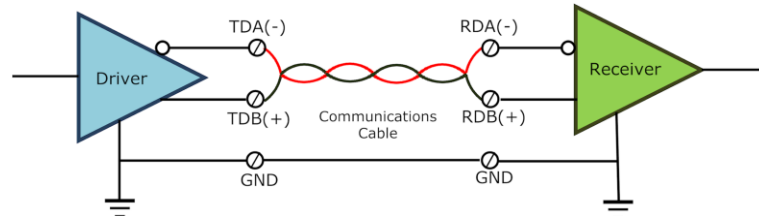

Figure 30: RS-422 Point-to-Point Connection

Shielding

It is often difficult to make a clear determination as to whether shielded cable is required in an application or not. Since the added cost of shielded cable is usually minimal in most cases it is worth installing the first time. If shielded cable is used, the shield should be grounded at one end only, preferably to earth ground.

It is not recommended to use a shield drain wire as the signal ground between RS-422/485 transceivers.

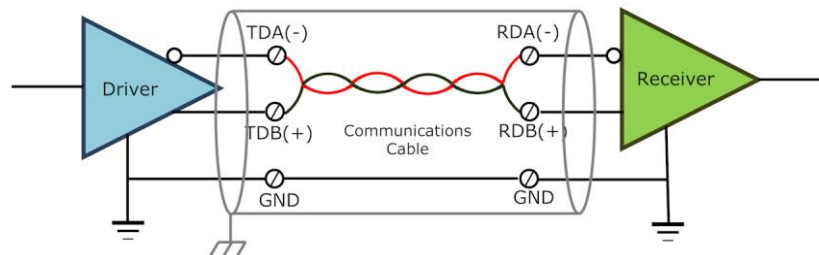

Figure 31: RS-422 Point-to-Point Connection

Note: The preceding diagram shows the use of a shield around the signal cable. Although there is some disagreement regarding the need for shielded cable, if a shield is used the drain wire should be connected to earth ground at one end only. Do not use the shield drain wire as the signal ground between RS-422/485 devices.

Cable Characteristics

When choosing a transmission line for RS-422 or RS-485, it is important to know the total length of the communication cable and the data rate of the system.

Cable Length vs Data Rate

The Appendix to the EIA RS-422-A Standard presents an empirical curve that relates cable length to data rate for 24 AWG twisted-pair telephone cable that has a shunt capacitance of 16 pF/ft, and is terminated in 100 ohms. This curve is based on the following signal quality requirements:

- Signal rise and fall time equal to, or less than, one-half unit interval at the applicable modulation rate.
- The maximum voltage loss between driver and load of 6 dB.

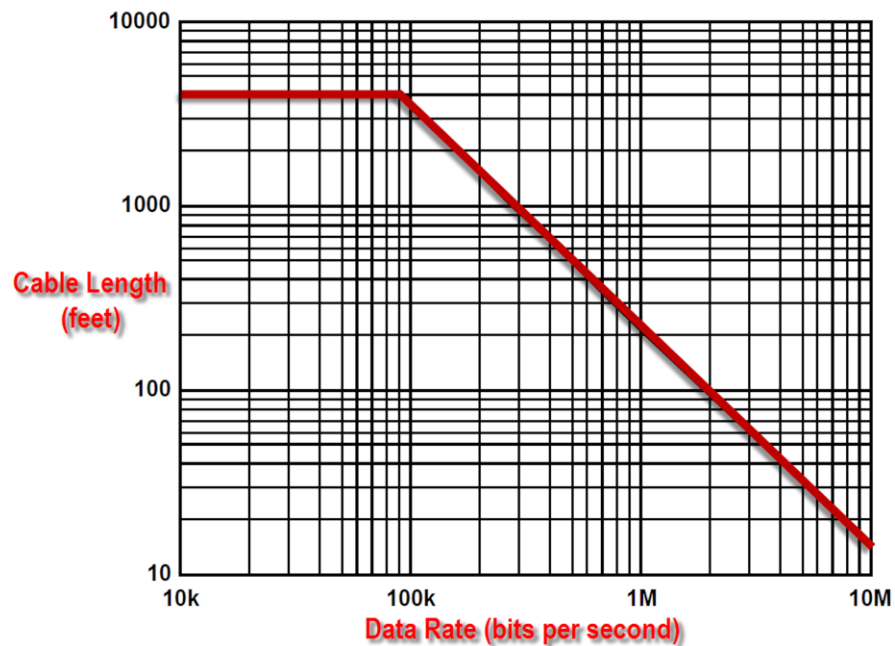

Figure 32: Cable Length vs Data Rate

In practical terms this graph indicates that RS-422/485 systems can have cable lengths up to 4000 feet when operating at less than

approximately 100 kbps. As data rates rise beyond 100 kbps, cable length drops off quickly. For example, at 200 kbps maximum cable length is approximately 1600 feet. At 1 Mbps cable length should not exceed approximately 200 feet.

Attenuation vs Frequency

Losses in a transmission line are a combination of AC losses (skin effect), DC conductor loss, leakage, and AC losses in the dielectric. In high quality cable, the conductor losses and the dielectric losses are on the same order of magnitude. The following graph demonstrates the significant difference in performance of different cables. This chart shows attenuation versus frequency for three different Belden cables. Note that the polyethylene cables offer much lower attenuation than PVC cables.

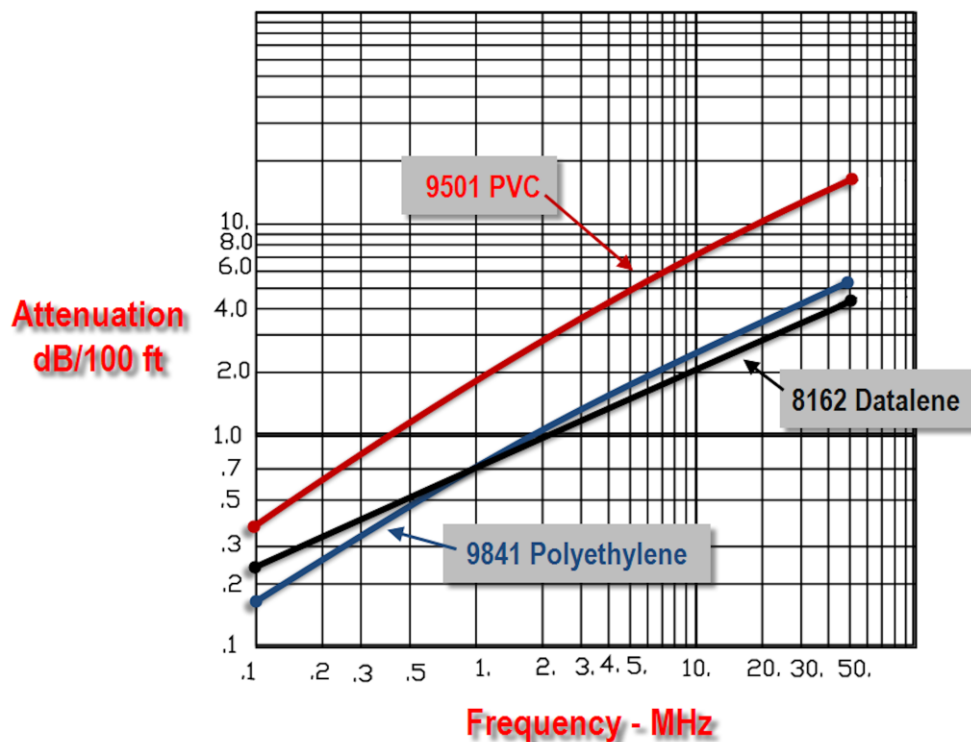

Figure 33: Cable Attenuation vs Frequency

Note 1: Above attenuation data is supplied courtesy Belden Wire and Cable Company

Note 2: Datalene is a registered trademark of Belden Wire and Cable Company. Datalene is a type of foamed cellular polyethylene insulation.

Using Cat 5 for RS-422/485

There are many cables available that meet the recommendations of EIA-422 and EIA-485. Another choice is the cable used in Ethernet network installations: Category 5 cable. Commonly referred to as "Cat 5" cable, its specifications are defined in the EIA/TIA/ANSI-568 specification. Because such a large volume of this cable is used, it is relatively inexpensive, often less than half the price of specialty RS-422/485 cabling. The cable has a maximum capacitance of 17 pF/ft (14.5 pF/ft typical) and characteristic impedance of 100 ohms.

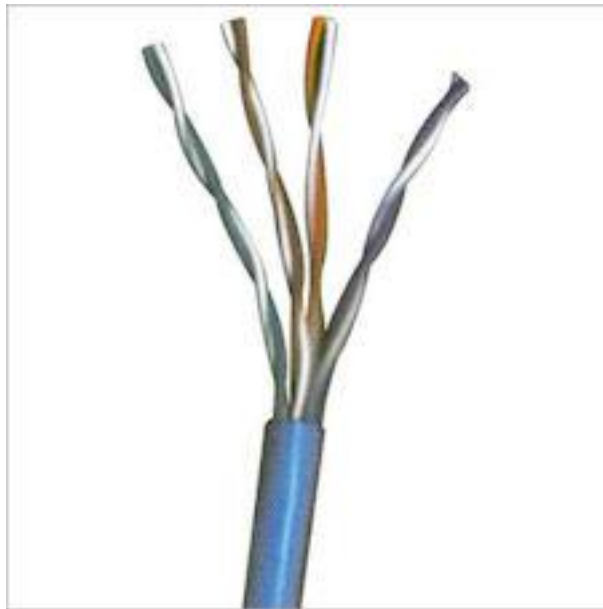

Figure 34: Category 5 Cable

Cat 5 cable is available as shielded twisted pair (STP) as well as unshielded twisted pair (UTP) and generally exceeds the recommendations for RS-422, making it an excellent choice for RS-422 and RS-485 systems.

CHAPTER 4

Transient Protection of RS-422 and RS-485 Systems

The first step towards protecting an RS-422 or RS-485 system from transients is understanding the nature of the energy we are guarding against. Transient energy may come from several sources, most typically environmental conditions or induced by switching heavy inductive loads.

In This Chapter

What does a surge look like?.....	49
When Ground is not really Ground	53
Transient Protection using Isolation	55
Transient Protection using Shunting.....	58
Combining Isolation and Shunting	60
Special Consideration for Fault Conditions	62
Choosing the right protection for your system.....	63

What does a surge look like?

While transients may not always conform to industry specifications, both the Institute of Electrical and Electronics Engineers (IEEE) and the International Electrotechnical Commission (IEC) have developed transient models for use in evaluating electrical and electronic equipment for immunity to surges. These models can offer some insight into the types of energy that must be controlled to prevent system damage.

Surge Specifications

Both of the following specifications provide useful information regarding transients:

- IEC 1000-4-5: 1995 "Surge Immunity Test"
- IEEE C62.41-1991 "IEEE Recommended Practice on Surge Voltages in Low-Voltage AC Power Circuits"

These documents define the parameters of a **1.2/50 μ s - 8/20 μ s combination wave** surge. The voltage versus time waveform for this surge has a 1.2 μ s voltage rise time with a 50 μ s decay across an open circuit.

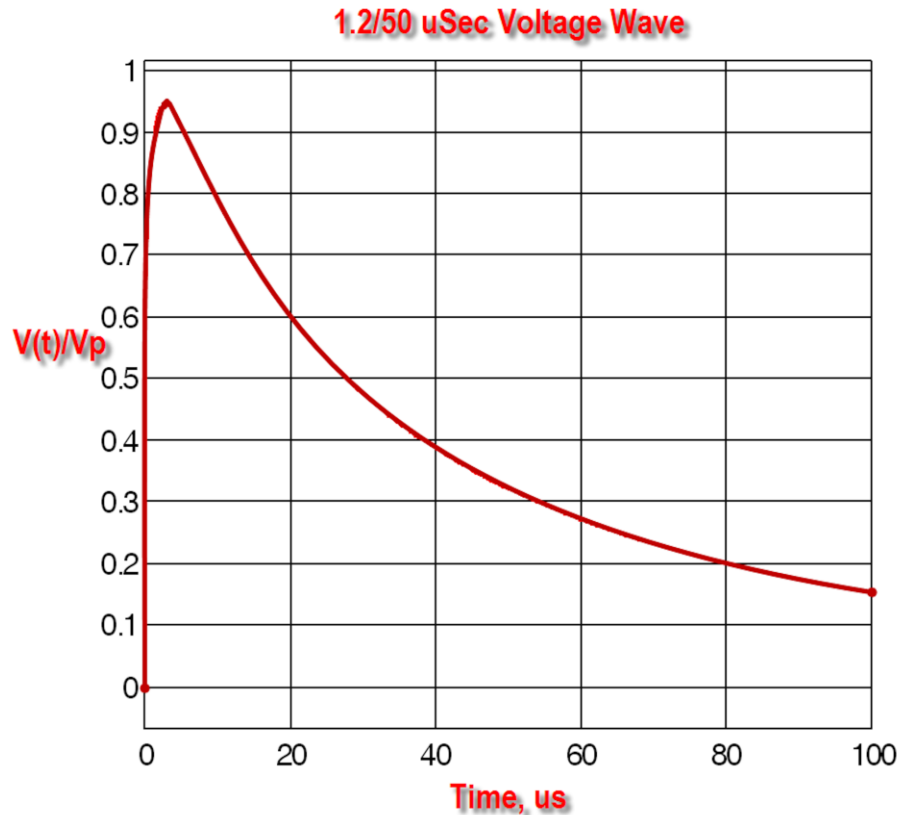

Figure 35: Combination Wave Voltage Waveform

The specified current waveform for this surge has an 8 μ s rise time with a 20 μ s decay into a short circuit.

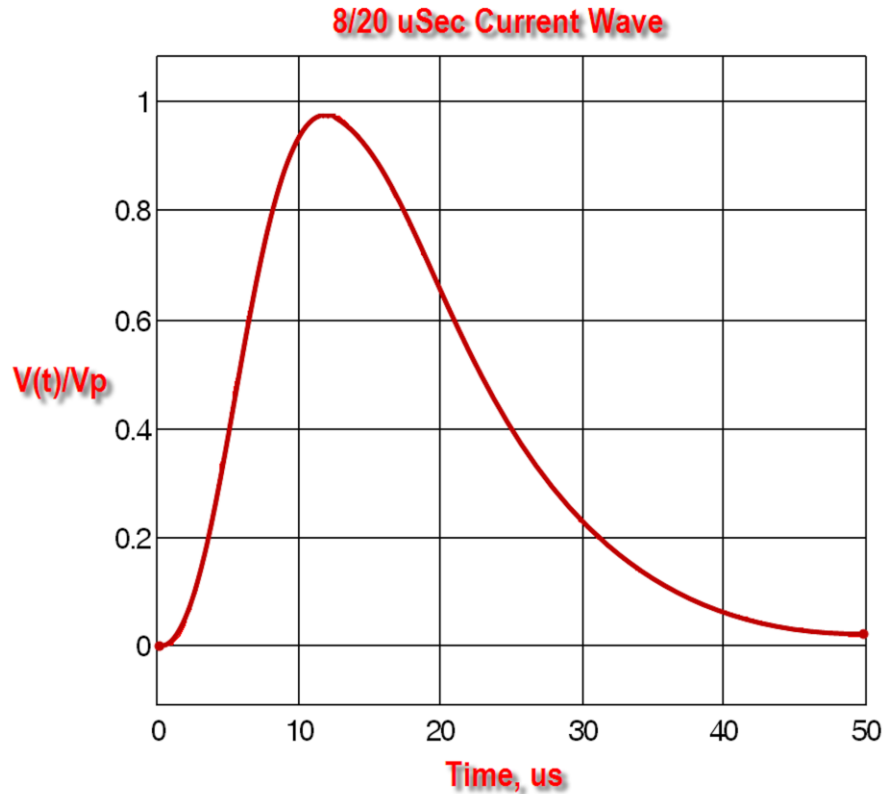

Figure 36: Combination Wave Current Waveform

Open circuit voltages levels from 1 kV to 6 kV are commonly used in both the positive and negative polarities, although, under some circumstances, voltages as high as 20 kV may be applied.

IEEE C62.41 also specifies a 100 kHz "ring wave" test. The ring wave has a $0.5 \mu\text{s}$ rise time and a decaying oscillation at 100 kHz with source impedance of 12 ohms. Typical amplitudes for the 100 kHz ring wave also range from 1 kV to 6 kV.

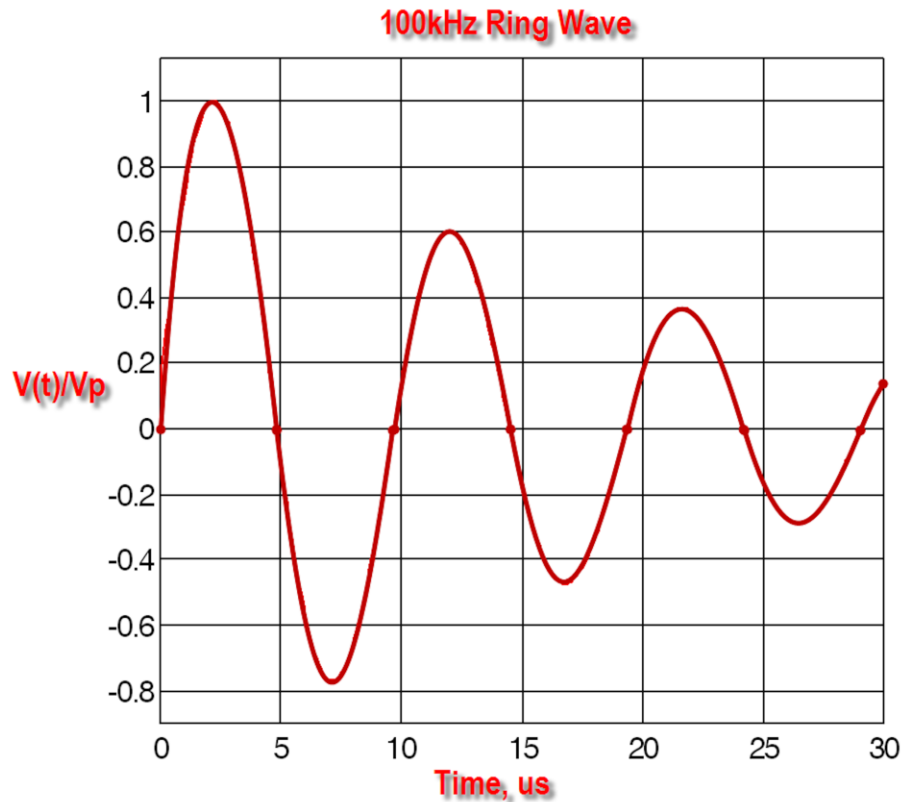

Figure 37: 100 kHz Ring Wave

Common Mode versus Differential Mode

Identifying the type of surges that may threaten a system is an important part of selecting the appropriate levels and methods of transient protection. Since each of the conductors in a data cable travels through the same physical space, it is reasonable to expect transients caused by environmental or current switching to be "common mode" that is, present on all data and ground conductors within the data cable.

In some installations, there may be another source of unwanted energy to consider. If there are high voltage cables running anywhere near the data cables, the potential for a fault condition exists as a result of insulation failures or inadvertent contact by an installer. This type of surge could contact any number of conductors in the data cable, presenting a "differential" surge to the data equipment. Although the voltages and currents associated with this type surge are much lower than the types of surges modeled by ANSI or IEC, they have a particularly destructive quality of their own. Instead of dissipating within several milliseconds, they can exist in a steady state condition on the data network.

When Ground is not really Ground

Realizing that transient energy can be high frequency in nature leads to some disturbing observations. At frequencies of this magnitude, it is difficult to make a low impedance electrical connection between two points due to the inductance of the path between them. Whether that path is several feet of cable or thousands of feet of earth between grounding systems, during a transient event there can be hundreds or thousands of volts potential between different "grounds". We can no longer assume that two points connected by a wire will be at the same voltage potential. To the system designer this means that although RS-422/485 uses 5V differential signaling, a remote node may see the 5V signal superimposed on a transient of hundreds or thousands of volts with respect to that node's local ground. It is more intuitive to refer to what is commonly called "signal ground" as a "signal reference".

How do we connect system nodes knowing that these large potential differences between grounds may exist?

The first step towards successful protection is to ensure that each device in the system is referenced to only one ground, eliminating the path through the device for surge currents searching for a return.

There are two approaches to creating this idyllic ground state. The first approach is to isolate the data ground from the host device ground, this is typically done with transformers or optical isolators.

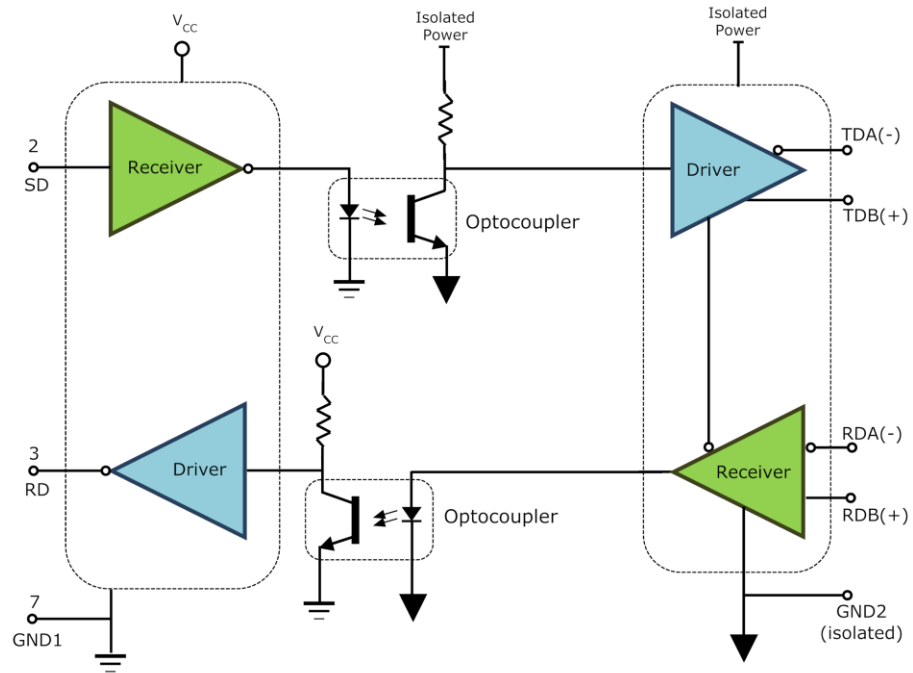

Figure 38: An Optically Isolated RS-485 Device

The second approach is to tie each of the grounds on a device together (typically power ground and data ground) with a low impedance connection.

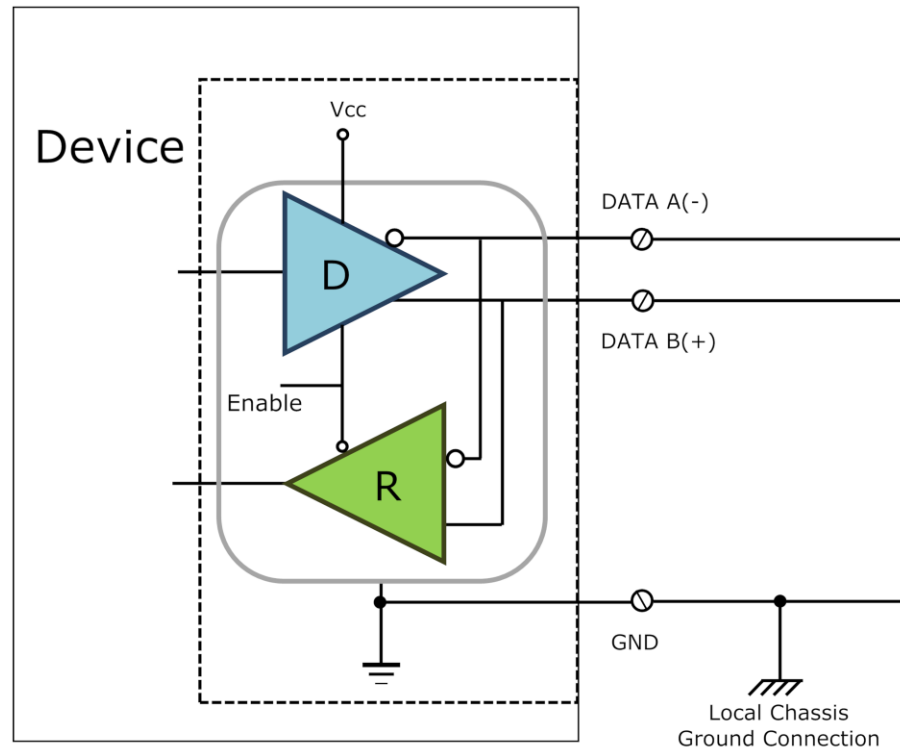

Figure 39: RS-485 Device with Signal Ground connected to Chassis Ground

These two techniques lead us to the two basic methods of transient protection.

Transient Protection using Isolation

Implementing transient protection can be a daunting task. An understanding of isolation theory, coupled with information on isolation devices, can be helpful in finding solutions.

Isolation Theory

The most universal approach to protecting against transients is to galvanically isolate the data port from the host device circuitry. This

method separates the signal reference from any fixed ground. Optical isolators, transformers and fiber optics are all methods commonly used in many types of data networks to isolate one section of a system from another.

In RS-422 and RS-485 applications, optical isolators have been the most common type of isolation for some time. An optical isolator is an integrated circuit that converts the electrical signal to light and back, eliminating electrical continuity. With an isolated port, the entire isolated circuitry floats to the level of the transient without disrupting data communications. As long as the floating level of the circuitry does not exceed the breakdown rating of the isolators (typically 1000 to 2500 volts) the port will not be damaged.

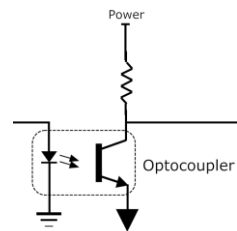

Figure 40: An Optocoupler

Some newer technologies are now using "digital isolators". Digital isolators combine CMOS technology with chip-scale micro-transformers into a single integrated circuit packages and provide superior performance over opto-couplers.

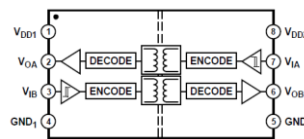

Figure 41: Digital Isolator Chip

Isolation technologies do not attempt to absorb or shunt excess energy so they are not sensitive to the length of the transient. Even continuous potential differences will not harm isolated devices.

It is important to note that isolators work on common mode transients; they cannot protect against large voltage differences between

conductors of a data cable such as those caused by short circuits between data and power circuits.

Isolation Devices

Optical isolation can be implemented in a number of ways. If a conversion from RS-232 to RS-422 or RS-485 is being made, optically isolated converters are available. Optically isolated ISA bus serial cards can replace existing ports in PC systems. For systems with existing RS-422 or RS-485 ports, an optically isolated repeater can be installed.



Figure 42: B&B 485OP Optically Isolated RS-485 Repeater

Additional examples of optically isolated devices can be found in the B+B SmartWorx Data Communications catalog.

Transient Protection using Shunting

Shunting Theory

Creating one common ground at the host device provides a safe place to divert surge energy as well as a voltage reference to attach surge suppression devices to. Shunting harmful currents to ground before they reach the data port is the job of components such as transient voltage suppressors (TVS), metal oxide varistors (MOV) or gas discharge tubes (GDT). These devices all work by "clamping" at a set voltage. Once the clamp voltage has been exceeded, the devices provide a low impedance connection between their terminals.

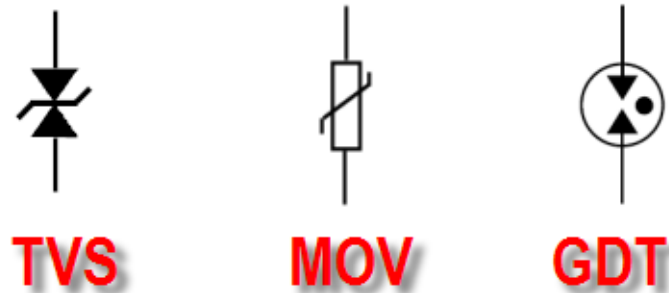

Figure 43: Transient Suppressor Symbols

Since this type of device diverts a large amount of energy, it cannot tolerate long durations or continuous transients. Shunting devices are most often installed from each data line to the local earth ground, and should be selected to begin conducting current at a voltage as close as possible above the system's normal communications levels. For RS-422 and RS-485 systems, the voltage rating selected is typically 6 to 8 volts. These devices typically add some capacitive load to the data lines. This should be considered when designing a system. Compensation for the added capacitance can be accomplished by derating the total line length. Several hundred feet is usually adequate.

Transient suppressors should be installed as close as possible to the port to be protected, and the user must provide an extremely low impedance connection to the local earth ground of the unit being

protected. This ground connection is crucial for proper operation of the shunting device. The ground connection should be made with heavy gauge wire and kept as short as possible. If the cable must be longer than one meter, copper strap or braided cable intended for grounding purposes must be used for the protection device to be effective. In addition to the high frequency nature of transients, an enormous amount of current may flow. Several thousand amps typically result from applications of the combination wave test in the ANSI and IEC specification.

Connecting Signal Grounds

Since a local ground connection is required at each node implementing shunt type protection, the consequences of connecting remote grounds together must be considered. During transient events a high voltage potential may exist between the remote grounds. Only the impedance of the wire connecting the grounds limits the current that results from this voltage potential. The RS-422 and RS-485 specifications both recommend using 100 ohm resistors in series with the signal ground path in order to limit ground currents. The following diagram illustrates the ground connection recommended in the specification.

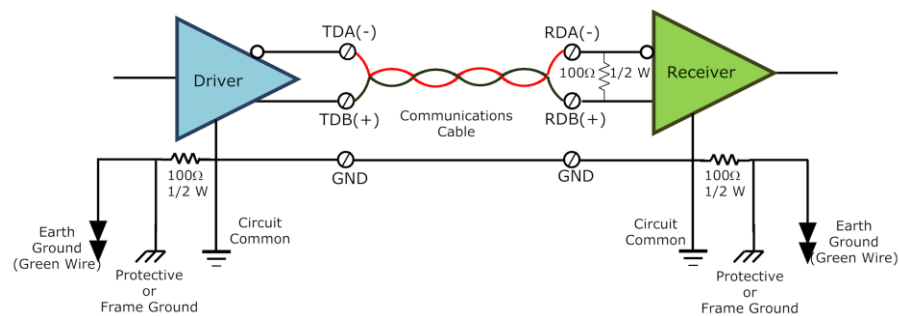

Figure 44: Signal Ground connection between two nodes with 100 ohm resistor

Note: If isolated devices are used between nodes on a network resistors are not required in the ground connection.

Shunting Devices

There are two types of shunting devices to choose from. The least expensive type is single stage, which usually consists of a single TVS device on each line. Three stage devices are also available. The first stage of a three-stage device is a gas discharge tube, which can handle extremely high currents, but has a high threshold voltage and is too slow to protect solid state circuits. The second stage is a small series impedance which limits current and creates a voltage drop between the first and third stage. The final stage is a TVS device that is fast enough to protect solid state devices and brings the clamping voltage down to a safe level for data circuits.

Combining Isolation and Shunting

Installing a combination of both isolation and shunting protection can offer the highest reliability in a system.

The following diagram shows an isolated RS-232 to RS-485 converter with TVS devices from both signal lines to ground. This method is recommended. Isolation protects the circuit from any voltage drops in the earth ground connection. The shunt devices prevent a surge from exceeding the breakdown voltage of the isolators as well as handling any differential surges on the cable.

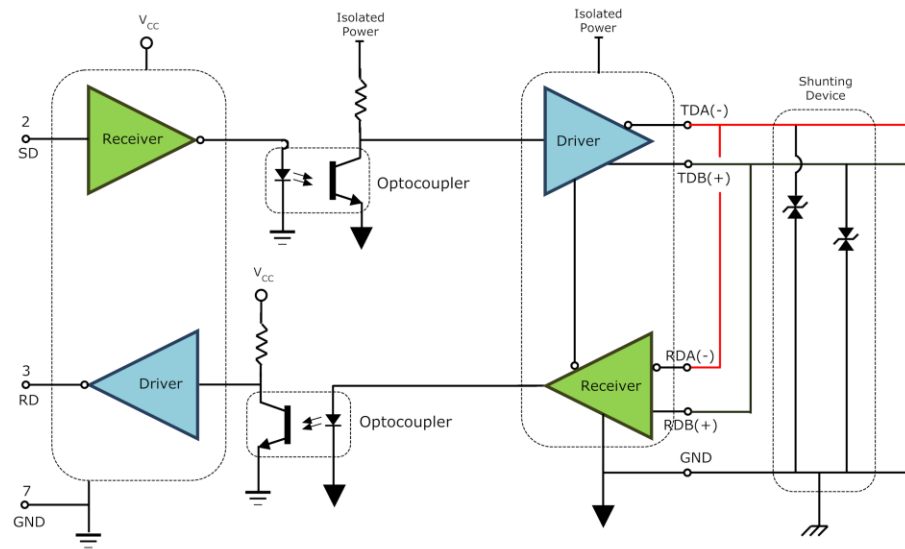

Figure 45: Isolated node with shunt protection to earth ground

The following diagram shows an isolated RS-232 to RS-485 converter with TVS devices connected across the signal lines, as well as from the signal lines to the signal ground. This method is recommended for cases where there is no way to make an earth ground connection. Here, the shunt device's function is to protect the port from differential surges, which will be balanced between conductors by the shunting device, converted to common mode. The isolation provides protection from any common mode transient remaining.

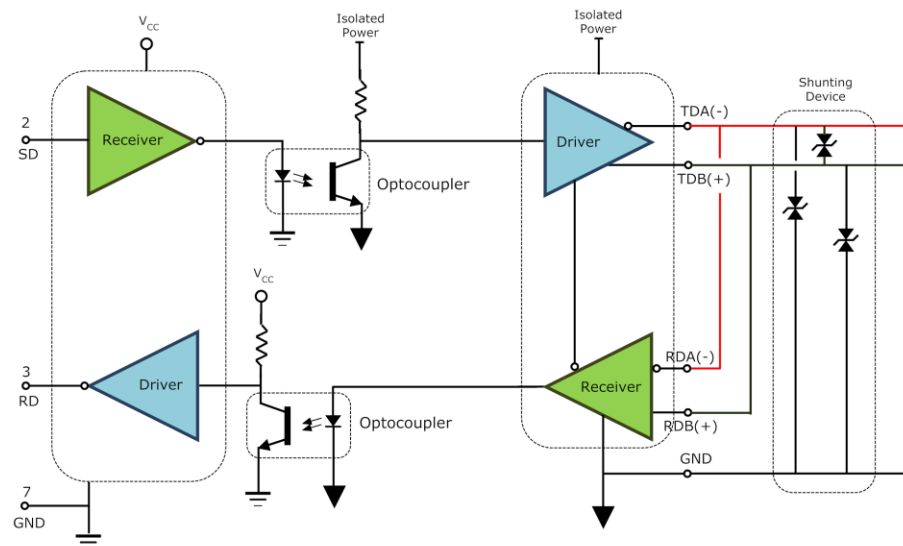

Figure 46: Isolated port with ungrounded shunt protection

Note: Sometimes when shunting protection is used at both ends of a run between two buildings, data communications are lost as soon as the second shunting device is grounded. This can happen when there are AC or DC voltages between the buildings. Usually it is recommended that isolation should be added at one end and shunting at the other, or isolation and shunting at one end and isolation at the other. The best solution is usually RS-485 to fiber converters between buildings. A few meters of fiber provides more than 2,000 volts of isolation.

Special Consideration for Fault Conditions

Data systems that could be exposed to short circuits to power conductors require an extra measure of protection. In these cases its

recommended to add a fuse type device in addition to shunting type suppression.

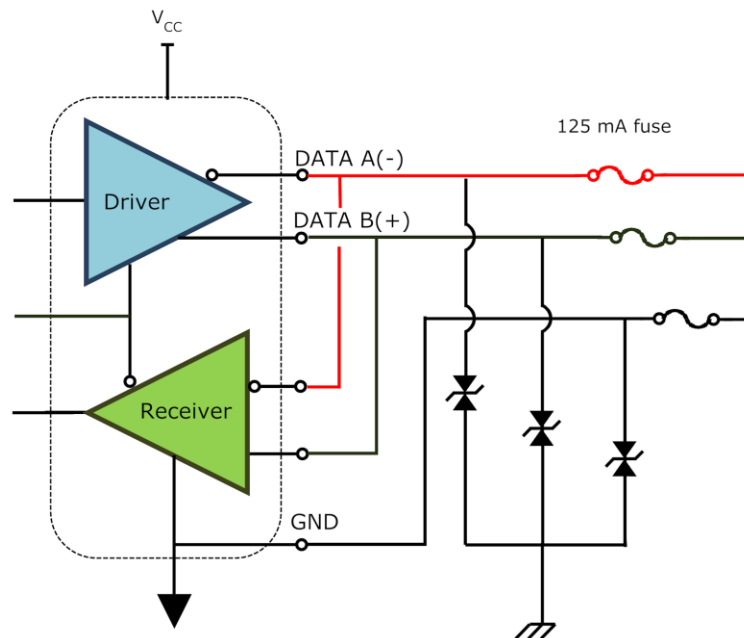

Figure 47: Fused Port Protection

When a short circuit occurs, the shunt suppression will begin conducting, but shunting by itself cannot withstand the steady state currents of this type of surge. A small enough fuse value should be chosen so that the fuse will open before the shunt device is damaged. A typical fuse value is 125 mA.

Choosing the right protection for your system

While it is difficult to predict what type and level of isolation is correct for a system, an educated guess should be made based on the electrical environment, physical conditions and cost of failures in downtime and repair costs. Systems connected between two power sources, such as building to building, office to factory floor, or any system covering long distances should require some level of transient protection. The following table compares transient protection techniques.

Optical Isolation	Shunting
Requires no ground reference	Must have low impedance ground path
Adds no loading to data lines	Presents additional capacitive loading to data lines
Higher complexity	Lower complexity, uses passive components
Effective on common mode transients	Effective on both common and differential mode transients
Not dependent on installation quality	Can be improperly installed by user
Requires an external power source	No power required
Not affected by long term or continuous transients	Subject to damage by long duration transients

CHAPTER 5

Software

RS-422 and RS-485 are hardware specifications. Protocols, which are implemented in software, are not discussed in either specification. Typically, in an existing system, the user is confined to using whatever software is part of the system. In the case of a system designer creating a new system, it may be possible to obtain, or define, a protocol suitable for their system.

This chapter does not attempt to define a protocol standard, but will explain some of the issues that must be understood by personnel installing, maintaining or designing RS-422/485 systems.

In This Chapter

RS-422 Systems	66
RS-485 Driver Control	66
RS-485 Receiver Control	68
Master-Slave Systems	68
Multi-Master RS-485 Systems	70
Systems with Port Powered Converters	71

RS-422 Systems

RS-422 system software differs little from that used with familiar point-to-point RS-232 communication systems. RS-422 is often used to simply extend the distance between nodes over the capabilities of RS-232. RS-422 can also be used as the master node in a four-wire master-slave network.

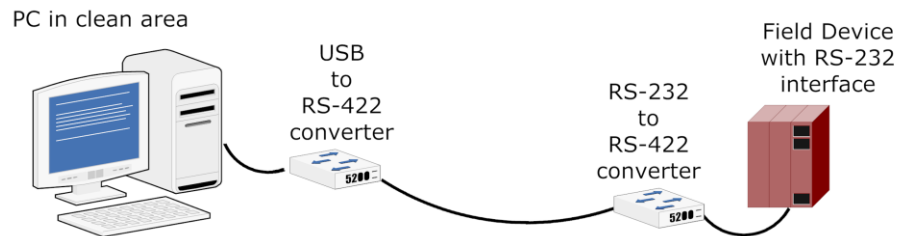

Figure 48: RS-422 Point-to-Point Link

When selecting or writing software for RS-422 systems the designer should be aware of the signals being used by the hardware in the system. Many RS-422 systems do not implement the hardware handshake lines often found in RS-232 systems due to the cost of running additional conductors over long distances.

RS-485 Driver Control

The principle difference between RS-422 and RS-485 is that the RS-485 driver can be put into a high impedance, tri-state mode, which allows other drivers to transmit over the same pair of wires. There are several methods of accomplishing this task.

One common method is to use a control line (often the RTS handshake line) to enable and disable the driver. The host software must assert the RTS line and enable the driver before beginning a transmission, then release the RTS line after the completion of the transmission. Since only a single RS-485 driver can be enabled on a network at one time it is important that the driver is disabled as quickly as possible after transmission to avoid two drivers trying to control the lines simultaneously, a condition called line contention.

Under some operating systems (Windows) it can be difficult to release RTS in a timely manner and this method of driver control should be avoided altogether.

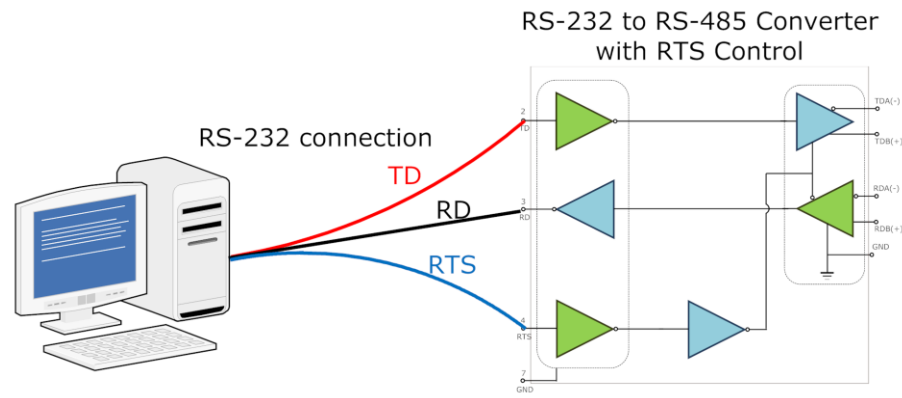

Figure 49: RS-485 RTS Driver Control

Another method of RS-485 driver control is Automatic Send Data Control. Internal circuitry senses when data is being transmitted and automatically enables the driver. It must then disable the driver within one character length of the end of transmission. This is the preferred method of driver control since it reduces software overhead and the number of potential pitfalls for the programmer.

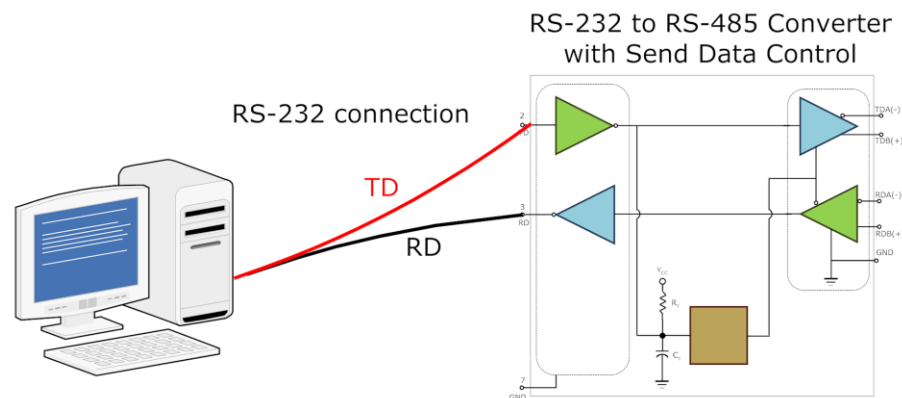

Figure 50: Automatic Send Data Driver Control

Other methods, such as bit-wise enable timing and auto-bauding may also be used in certain situations. Refer to the section on Tri-State Control (on page 16) earlier in this document.

RS-485 Receiver Control

The RS-485 receiver also has an enable input. Since RS-485 systems using a two-wire configuration connect the driver to receiver in a loopback fashion, this feature is often used to disable the receiver during transmission to prevent the echo of local data. Another approach is to leave the RS-485 receiver enabled and monitor the loopback data for errors which would indicate that line contention has occurred. Although a good loopback signal does not guarantee data integrity, it does offer a degree of error detection.

Master-Slave Systems

A master-slave system has one master node that issues commands to each of the slave nodes and processes responses. Slave nodes do not typically transmit data without a request from the master node, and do not communicate with each other. Each slave must have a unique address so that it can be addressed independently of other nodes. These systems can be configured as two-wire or four-wire. Four-wire systems may use an RS-422 master (the driver is always enabled) and RS-485 slaves to reduce system complexity.

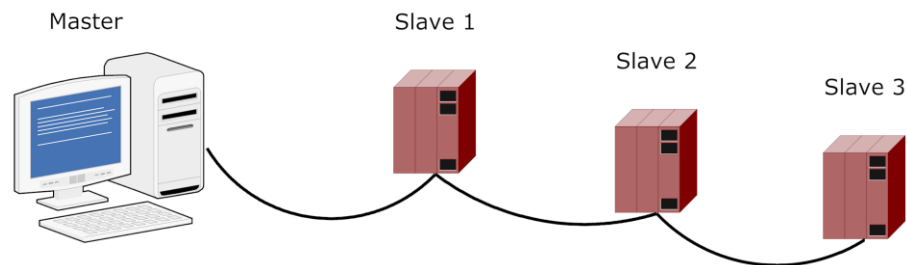

Figure 51: A Master/Slave System

Four Wire Master-Slave Systems

This configuration reduces software complexity at the host since the driver and receiver are always enabled, at the expense of installing two extra conductors in the system. The master node simply prefixes

commands with the appropriate address of the slave. There is no data echo or turn around delays to consider. Since each of the slave transmitters share the same pair of wires, care must be taken that the master never requests data from multiple nodes simultaneously or data collisions will result.

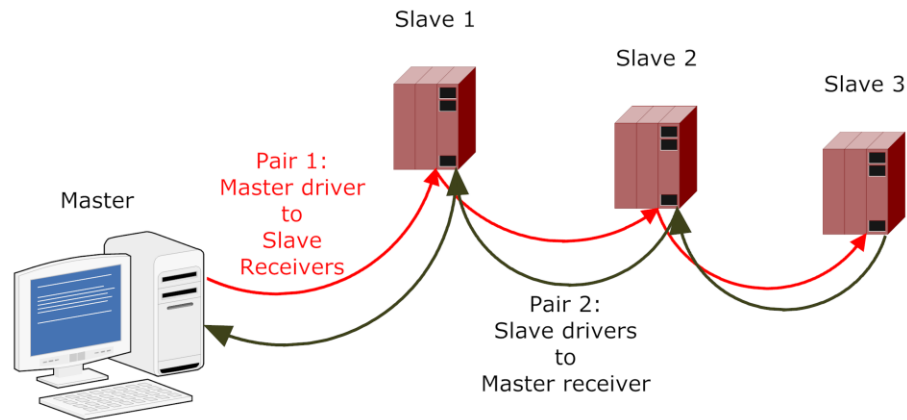

Figure 52: Four-Wire Master-Slave System

Two Wire Master-Slave Systems

Two wire configurations add a small amount of complexity to the system. The RS-485 driver must be tri-stated when not in use to allow other nodes to use the shared pair of wires. The time delay between the end of a transmission and the tri-state condition becomes a very important parameter in this type system. If a slave attempts to reply before the master has tri-stated (released) the line, a collision will occur and data will be lost. The system designer must know the response time or turn around delay of each of the slave nodes and assure that the master will tri-state its driver within that amount of time. B+B SmartWorx' Automatic Send Data control circuits tri-state the driver within one character length of the end of a transmission.

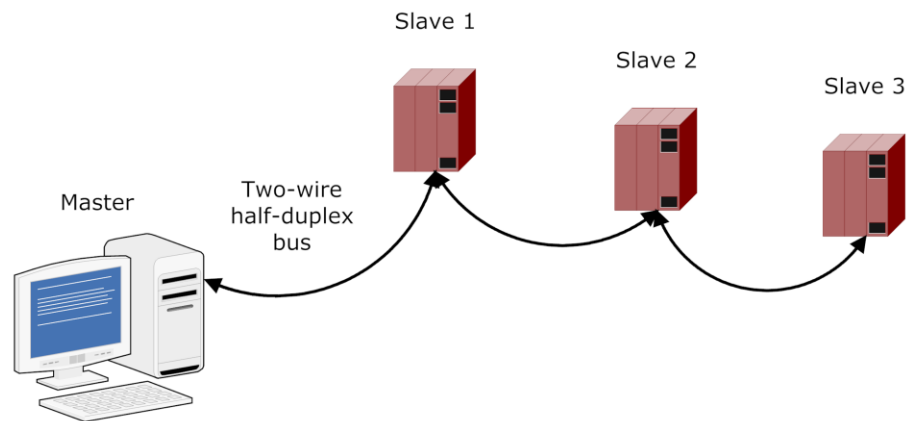

Figure 53: Two-wire Master-Slave System

Multi-Master RS-485 Systems

Each node in a multi-master type RS-485 system can initiate its own transmission creating the potential for data collisions. This type system requires the designer to implement a more sophisticated method of error detection, including methods such as line contention detection, acknowledgment of transmissions and a system for resending corrupted data.

Systems with Port Powered Converters

RS-232 to RS-422 or RS-485 converters that derive their power from the RS-232 port are becoming more common in data systems. Power is supplied to the converter via asserted hardware handshake lines in the RS-232 connection. For this to work the software must assert the required line(s) when it starts and maintain them in this state. Because RTS (and sometimes DTR) lines are used for RS-485 driver control in some systems, other handshake lines must be used for port powering in those situations. Converter technical documents typically provide information on RTS and Send Data control configuration, as well as port powering requirements.

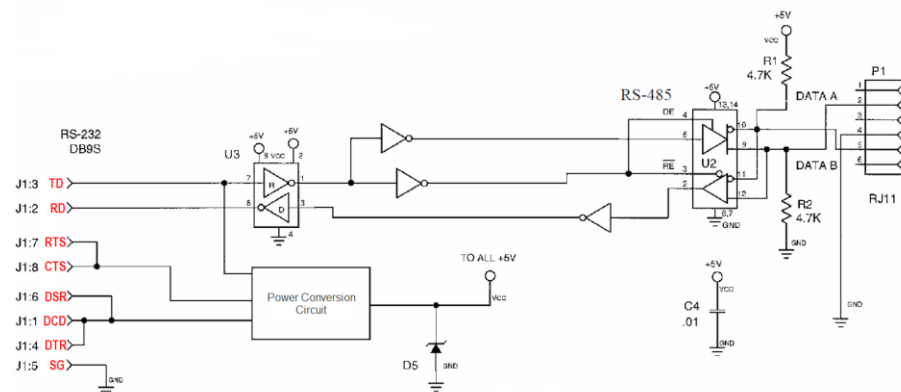

Figure 54: Handshake Connections to a Port Powered Converter

A good programming practice is to set unused handshake outputs to a high voltage state in systems using any type of RS-232 to RS-422 or RS-485 converter. This will assure the best possible operating conditions for all converters used.

CHAPTER 6

RS-485 Devices

This section describes several common devices that facilitate the use of RS-422 and RS-485 in practical applications.

Note: Some of the categories listed overlap because some devices provide several features in one package. For example, optically isolated RS-232 to RS-422/485 converters are listed in the RS-232 to RS-422/485 section as well as the Optically Isolated Devices section.

In This Chapter

RS-232 to RS-485 Converters	74
PC Serial Interface Cards	75
USB to RS-422/485 Converters	76
Port Powered Converters	77
Repeaters	78
Optically Isolated RS-422/485 Devices	79

RS-232 to RS-485 Converters

Although RS-232 serial interfaces are less commonly found on personal computers than in years past, RS-232 is still employed to many legacy and some current commercial and industrial systems. In many practical applications it is useful to be able to convert RS-232 to RS-422 or RS-485 to increase distance and speed capabilities.



Figure 55: RS-232 to RS-422/485 Converters

RS-232 to RS-422/485 converters are available with a range of features.

- Externally powered converters
- Port powered converters
- Optically isolated converters
- Addressable converters
- Multi-channel converters
- Industrial converters (DIN rail mountable, industrial enclosures, etc)

PC Serial Interface Cards

RS-422/485 interfaces on PCI, PCMCIA, CF and ISA cards can be used to add ports to any PC.



Figure 56: Serial Interface Cards

Examples include:

- Multi-interface cards
- Optically isolated outputs
- Low profile PCI
- PCMCIA (PC card)
- Express cards
- ISA cards

USB to RS-422/485 Converters

Universal Serial Bus (USB) is a serial protocol and physical layer link. Data is transmitted differentially on one pair of wires, providing relatively good noise immunity. Another pair carries DC power to downstream devices, allowing many low power devices to be bus powered. USB supports a high data rate and "hot swap" connection for PCs, providing an easy connection to a wide variety of multimedia and network USB devices. Most PCs today do not come equipped with RS-232 ports. USB has become the standard serial interface on PCs (and increasingly on other equipment).



Figure 57: A USB to RS-422/485 Converter

Examples of USB to RS-422/485 devices include the following:

- In-line USB to RS-232, RS-422 and RS-485 converters
- Isolated converters
- Panel mount converters
- DIN rail mountable converters
- Multiple port converters

Port Powered Converters

Port powered converters derive their power from the connected RS-232 device's output signals. Typically, to power the port, the communications software asserts the RTS or DTR line in the RS-232 port. The voltage and current from the asserted line is used to power the internal circuitry of the converter.



Figure 58: A Port Powered RS-232 to RS-485 Converter

Examples of port powered converter features include:

- Two-wire converters
- Four-wire converters
- Converters with various types of connectors:
 - DB-9 connectors
 - DB-25 connectors
 - Terminal block connectors
 - RJ-11 connectors

Repeaters

When using standard components a RS-422 driver can drive up to 10 standard receivers. A standard RS-485 driver can drive up to 32 standard receivers. Repeaters allow you to extend the number of receivers on a network. The repeater receives data on its input and recreates it on its outputs, which can then drive another maximum number of nodes. Often repeaters are also optically isolated ensuring that the effects of any differences in common mode voltage between network legs are eliminated.



Figure 59: RS-232 to RS-422/485 Converters

Examples of features related to repeaters include:

- Optical isolation
- Industrial enclosures
- DIN rail mountable

Optically Isolated RS-422/485 Devices

Optical isolation protects electronic devices from transient surges and differences in ground potentials. Industrial applications are particularly susceptible to data corruption or destruction of electronic devices because of electric motors starting, lightning strikes and other events. Isolators can provide 2000 volts of isolation between input and output.

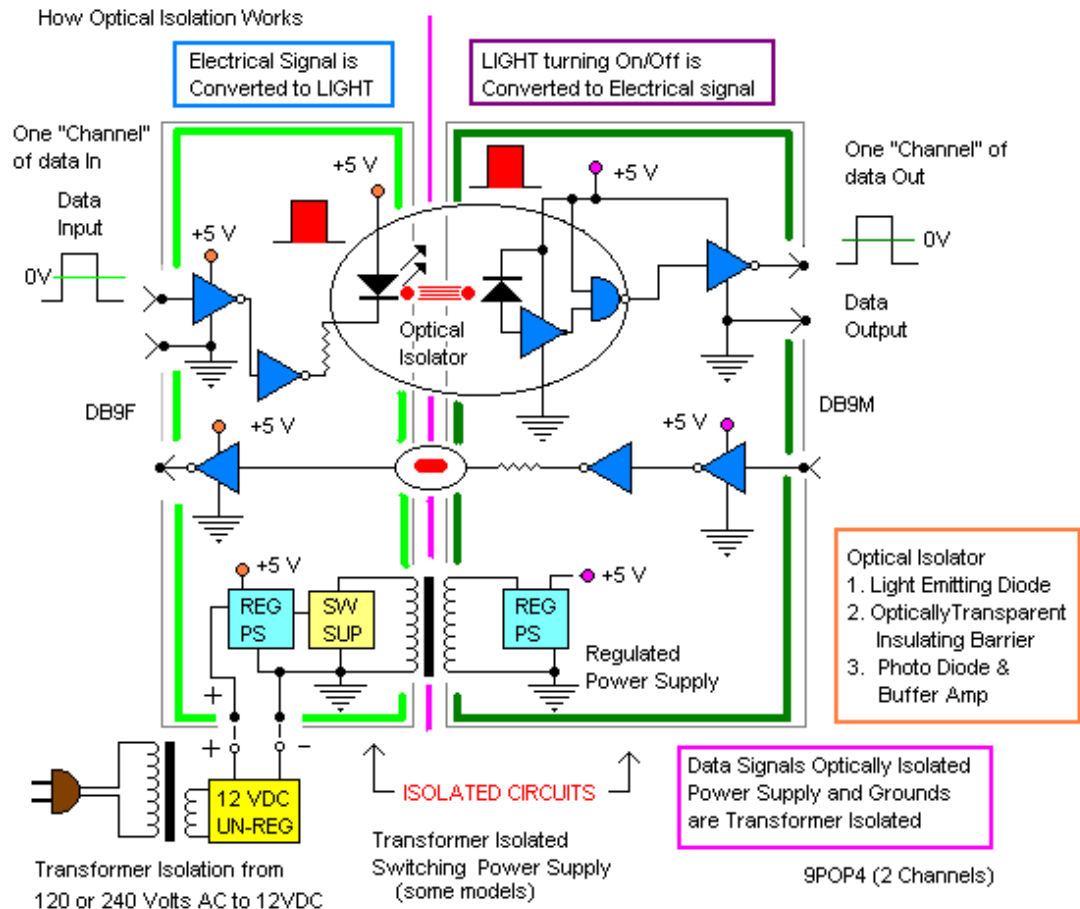

Figure 60: An Optically Isolated Device

Examples of devices and features of optically isolated devices include:

- RS-232 to RS-485 conversion
- RS-422 four-wire to RS-485 two-wire conversion
- Repeaters

- Industrial enclosures, specifications and mounting options

CHAPTER 7

Sources of Additional Information

Additional information about EIA/TIA standards and technologies is available from the sources listed in this section.

In This Chapter

Global Engineering	81
List of EIA/TIA Standards.....	82
Integrated Circuit Manufacturers	82
Other sources of information.....	83

Global Engineering

EIA Standards and Publications can be purchased from:

GLOBAL ENGINEERING DOCUMENTS

7730 Carondelet Avenue
 Clayton, MO 63105
 Phone: (800) 854-7179
 FAX: (314) 726-6418

GLOBAL ENGINEERING DOCUMENTS

15 Inverness Way East
 Englewood, CO 80112
 Phone: (800) 854-7179
 FAX: (303) 397-2740

Global Engineering Documents web site can be found at
<http://global.ihs.com> <http://global.ihs.com>

List of EIA/TIA Standards

EIA/TIA data interface standards include:

- EIA-232-E Interface between data terminal equipment and data circuit-terminating equipment employing serial binary data interchange (ANSI/IEA-232-D)
- EIA-422-A Electrical characteristics of balanced voltage digital interface circuits
- EIA-423-A Electrical characteristics of unbalanced voltage digital interface circuits
- EIA-485 Standard for electrical characteristics of generators and receivers for use in balanced digital multipoint systems
- EIA-449 General purpose 37-position and 9-position interface for data terminal equipment and data circuit-terminating equipment.
- EIA-530 High speed 25-position interface for data terminal equipment and data circuit-terminating equipment
- EIA/TIA-562 Electrical characteristics for an unbalanced digital interface

Integrated Circuit Manufacturers

Manufacturers of integrated circuit data transceivers often offer practical application information for RS-422 and RS-485 systems.

National Semiconductor's Interface Data Book includes a number of excellent applications notes. These notes are also available online at <http://www.national.com/>. A search engine is provided to search the text of the available application notes. Entering "422" or "485" as search criteria to get a current list of related application notes.

Other sources of information

Jan Axelson's book, *Serial Port Complete*, is an excellent source of both general serial port information as well as RS-485 information.

APPENDIX A

EIA Specification Summary

The following tables bring together the most important specifications and information for the EIA/TIA-232, 422, 423, and 485 standards.

EIA-422 Specifications

EIA RS-422 Specification Summary				
Parameter	Conditions	Min	Max	Units
Driver Output Voltage			10	V
Open Circuit			-10	V
Driver Output Voltage Loaded	RT = 100 ohms	2		V
		-2		V
Driver Output Resistance	A to B		100	ohms
Driver Output Short-Circuit Current	Per output to common		±150	mA
Driver Output Rise Time	RT = 100 ohms		10	% of Bit Width
Driver Common Mode Voltage	RT = 100 ohms		±3	V
Receiver Sensitivity	Vcm = -7 to +7v		±200	mV
Receiver Common-Mode Voltage Range		-7	+7	V
Receiver Input Resistance		4000		ohms
Differential Receiver Voltage	Operational:		±10	V
	Withstand:		±12	V

EIA-485 Specifications

EIA RS-485 Specification Summary				
Parameter	Conditions	Min	Max	Units
Driver Output Voltage Open Circuit		1.5	6	V
		-1.5	-6	V
Driver Output Voltage Loaded	RLOAD = 54 ohms	1.5	5	V
		-1.5	-5	V
Driver Output Short-Circuit Current	Per output to +12V or -7V		±250	mA
Driver Output Rise Time	RLOAD = 54 ohms CLOAD = 50 pF		30	% of Bit Width
Driver Common Mode Voltage	RLOAD = 54 ohms	-1	3	V
Receiver Sensitivity	Vcm = -7 to +12v		±200	mV
Receiver Common-Mode Voltage Range		-7	+12	V
Receiver Input Resistance		12K		ohms

EIA-232 Specifications

EIA RS-232 Specification Summary				
Parameter	Conditions	Min	Max	Units
Driver Output Voltage Open Circuit			25	V
Driver Output Voltage Loaded	RL = 3 kohm to 7 kohm	5	15	V
Driver Output Resistance, Power Off	Vo = -2V to 2V		300	ohm
Driver Output Short-Circuit Current			500	mA
Driver Output Slew Rate			30	V/us
Maximum Load Capacitance			2500	pF
Receiver Input Resistance	Vin = 3V to 25V	3000	7000	ohm
Receiver Input Threshold				
Output = Mark		-3		V
Output = Space			3	V

EIA-423 Specifications

EIA RS-423 Specification Summary				
Parameter	Conditions	Min	Max	Units
Driver Output Voltage Open Circuit		4	6	V
		-4	-6	V
Driver Output Voltage Loaded	RL = 450 ohm	3.6	6	V
Driver Output Resistance	Vo = -2V to 2V		50	ohm
Driver Output Short-Circuit Current			±150	mA
Driver Output Rise and Fall Time	Baud Rate less than 1K Baud		300	us
	Baud Rate greater than 1K Baud		30	% Unit Interval
Receiver Sensitivity	Vcm = -7V to +7v		±200	mV
Receiver Input Resistance		4000		ohm

Comparison of RS-232, RS-423, RS-422 and RS-485 Specifications

The main difference by RS-422 and RS-485 systems is the ability of RS-485 to tri-state its outputs, enabling multiple drivers to be used in a multidrop network configuration. However, there are other subtle differences between the standards.

Another significant difference is the number of receivers that can be driven on a communications line. The EIA-422 standard specifies that one RS-422 driver can drive up to 10 RS-422 receivers. The EIA-485 standard specifies that one RS-485 driver can drive up to 32 receivers. (Up to 32 RS-485 drivers can be connected to the communications line as long as only one is enabled at a time.)

Note: Some manufacturers' devices are designed to present fractional unit loads (UL) to the network. For example, some devices are rated as 1/4 UL meaning four receivers add the same load as one standard device. This increases the effective maximum possible number of devices on a network significantly.

The following table provides additional specifications for RS-232, RS-422 and RS-485:

Specifications	RS-232	RS-423	RS-422	RS-485
Mode of Operation	Single-ended	Single-ended	Differential	Differential
Total Number of Drivers and Receivers on One Line (One driver active at a time for RS485 networks)	1 driver 1 receiver	1 driver 10 receivers	1 driver 10 receivers	32 drivers 32 receivers
Maximum Cable Length	50 ft	4000 ft	4000 ft	4000 ft
Maximum Data Rate (40ft. - 4000ft. for RS422/RS485)	20 kbps	100 kbps	100 kbps to 10 Mbps	100 kbps to 10 Mbps
Maximum Driver Output Voltage	±25 V	±6 V	-0.25 V to +6 V	-7 V to +12 V
Driver Output Signal Level (Loaded Min.) - Loaded	±5 V to ±15 V	±3.6 V	±2 V	±1.5 V
Driver Output Signal Level (Unloaded Max) - Unloaded	±25 V	±6 V	±6 V	±6 V
Driver Load Impedance (Ohms)	3k ohm to 7k ohm	≥450 ohm	100 ohms	54 ohms
Max. Driver Current in High Z State	n/a	n/a	n/a	±100µA
Max. Driver Current in High Z State	±6 mA @ ±2 V	±100 µA	±100 µA	±100 µA
Slew Rate (Max.)	30 V/µS	Adjustable	n/a	n/a
Receiver Input Voltage Range	±15 V	±12 V	-10 V to +10 V	-7 V to +12 V
Receiver Input Sensitivity	±3 V	±200 mV	±200 mV	±200 mV
Receiver Input Resistance (Ohms), (1 Standard Load for RS485)	3 kohm to 7 kohm	4 kohm min	4 kohm min	greater than 12 kohm

APPENDIX B

EIA Standard RS-423 Data Transmission

RS-423 (EIA-423) is another standard used in point to point communications. RS-423 data transmission uses an unbalanced line driver that connects to an RS-422 type balanced line receiver. The RS-423 line driver is unique to this system. It produces voltage similar to RS-232 but has a slew rate control input that is used to limit rise times and cross talk on the data lines. Typical adjustment on the slew rate control is from 1 to 100 μ s. This is done by selecting a resistor on the wave shape control input.

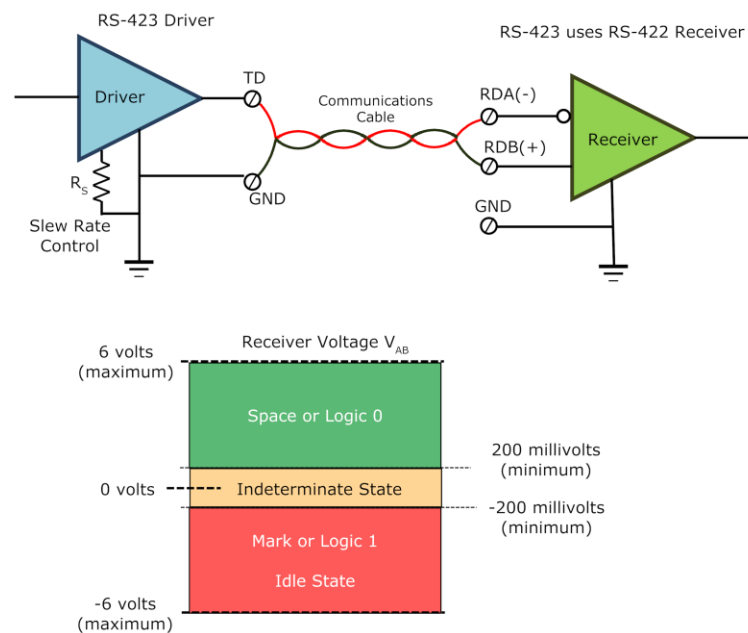

Figure 61: RS-423 Interface Circuit

APPENDIX C

Testing and Troubleshooting RS-422/485 Systems

This section provides resources to assist you with testing and troubleshooting RS-422 and RS-485 systems.

Selecting RS-485 Devices

When purchasing devices for an RS-485 system many pitfalls can be avoided by determining the device's communications characteristics before the system design is complete. Knowing what questions to ask up front can save a lot of troubleshooting in the field.

The following device characteristics are all things that should be answered in the system design stage.

1. Is the device configured for two-wire or four-wire systems?
2. Is a signal ground connection available?
3. Is the device isolated? Does it contain surge suppression?
4. What value bias resistors (if any) are used in the device? Are they accessible for modification?
5. Is the device terminated? Is it accessible for modification?
6. What is the device's response time (turn around delay)?
7. What is the programmable address range of the device?
8. What baud rate, or range of baud rates, is supported?

If possible it is often useful to have a schematic of the serial port of each device in a system. The schematic can provide additional information that may be useful in troubleshooting or repairing any problems in the data system.

Troubleshooting Checklist

The following checklist may be helpful in eliminating RS-422/485 problems:

1. Get a schematic of each serial port to assist in troubleshooting and repairs.
2. Ensure data signals are within the 200 mV to 6 V range necessary for RS-422/485 communication.
3. Use a signal ground line to keep common mode voltage within the -7 V to +12 V range.
4. Verify that only one RS-485 driver at a time is enabled on the communications line.
5. Use isolated equipment if possible to avoid problems with different ground potentials and noise.
6. Add fused output devices to shunting protection to guard against short circuits.
7. Is the data rate high enough to require termination resistors?
8. If you have added termination resistors, did you check the biasing to ensure the system would operate?

Troubleshooting Flowchart

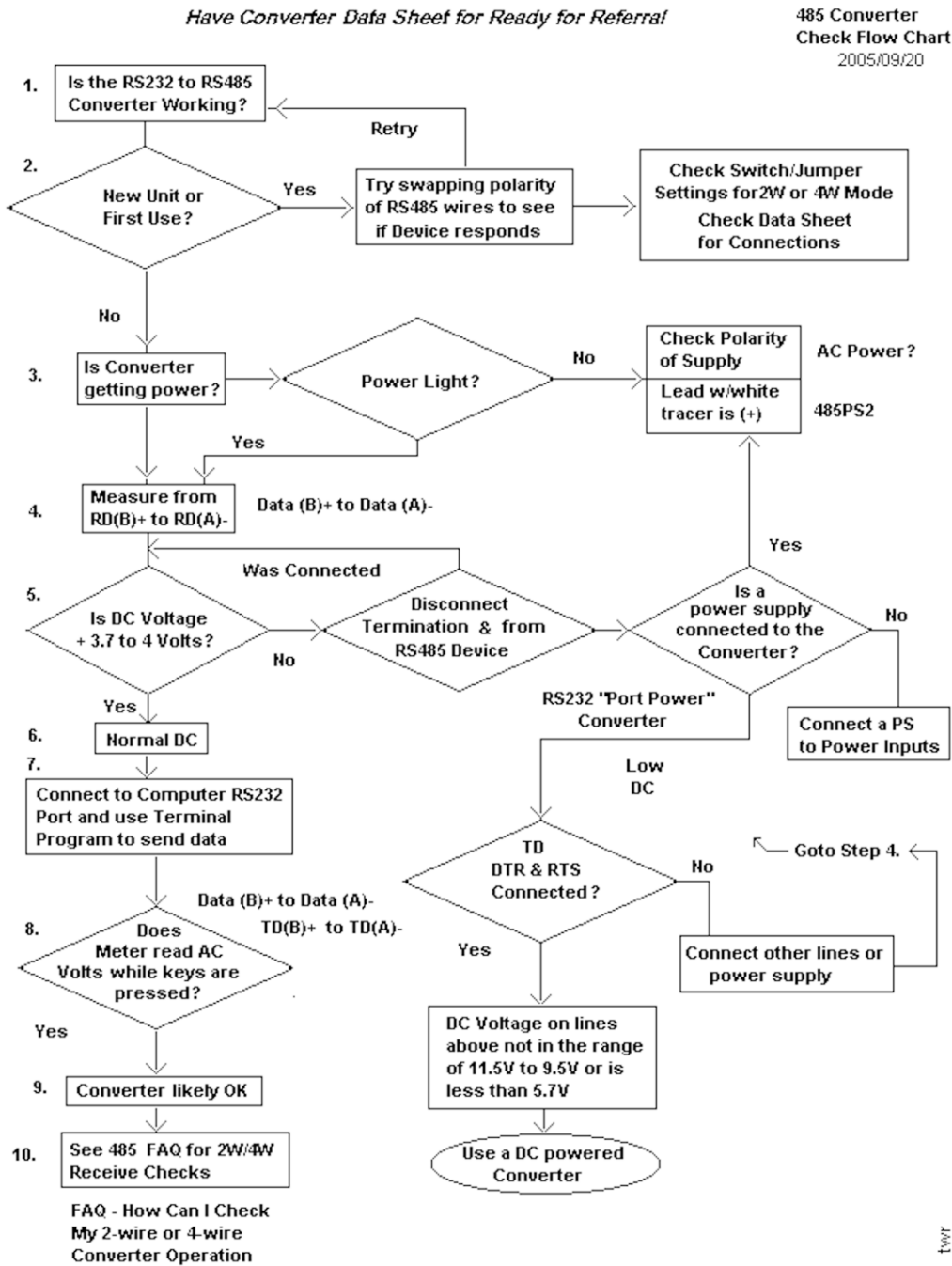

Figure 62: RS-232 to RS-485 Converter Troubleshooting Flowchart

RTS Control Timing Diagrams

The following diagram shows the timing relationships between the data and control signals used to accomplish RTS control in an RS-232 to RS-485 converter.

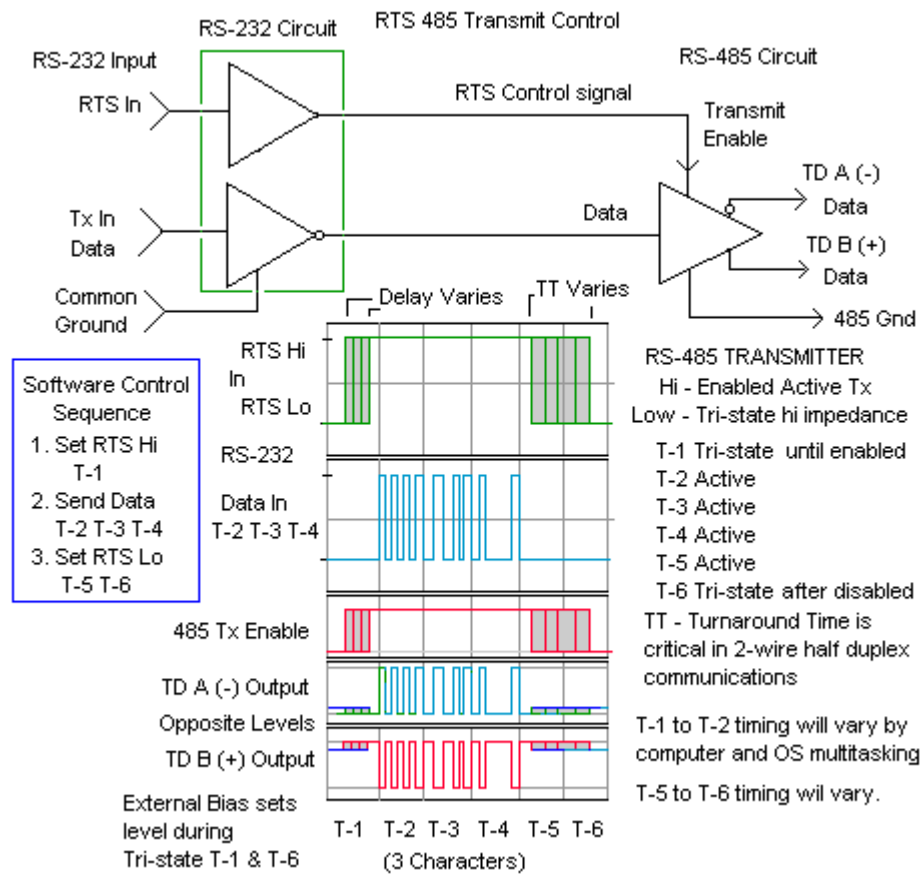

Figure 63: RTS Timing

Send Data Control Timing Diagrams

The following diagram shows the timing relationships between the data and internal control signals used to accomplish send data control in an RS-232 to RS-485 converter.

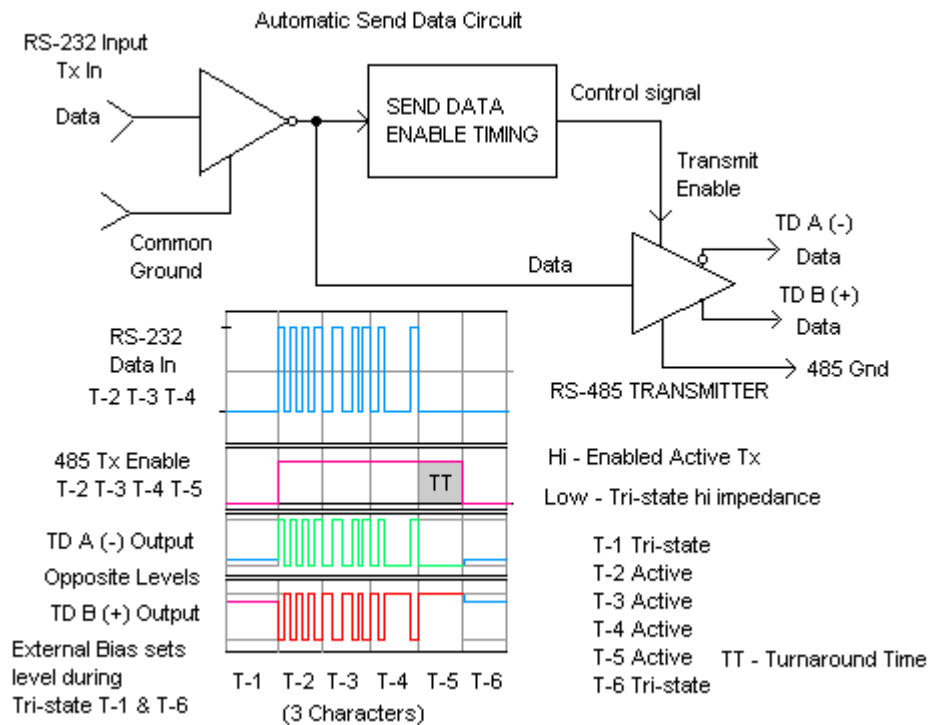

Figure 64: Send Data Timing

Bit-Wise Enable Timing Diagrams

The following diagram shows the timing relationships between the data and internal control signals used to accomplish bit-wise enable control in an RS-232 to RS-485 converter.

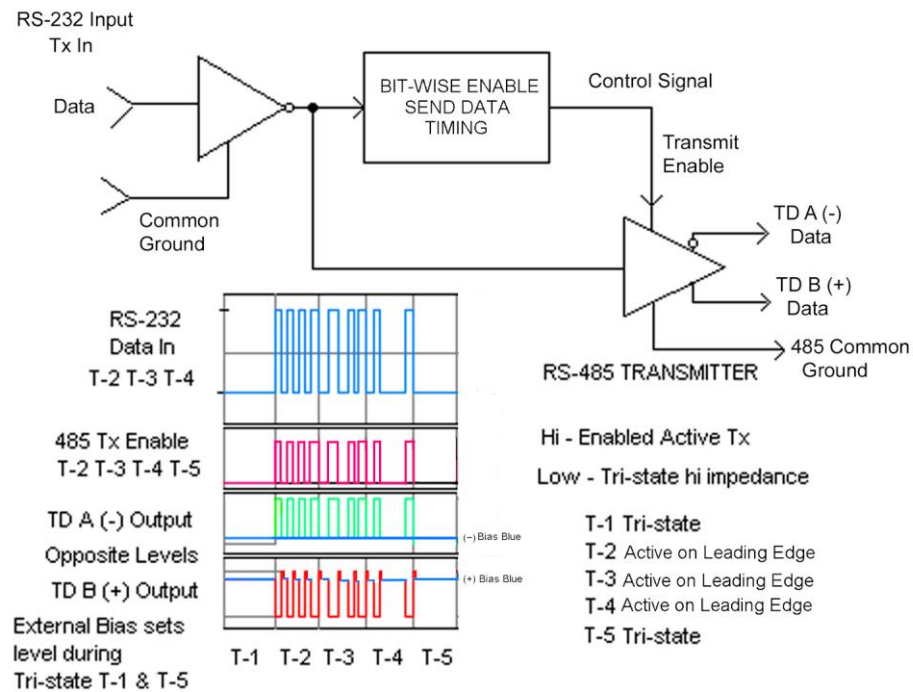

Figure 65: Bit-Wise Enable Timing Diagram

Glossary of Terms

Symbols & Numeric

485 Driver Control

RS-485 transmitters must be enabled to transmit or disabled when not transmitting. When disabled, the transmitter output presents a high impedance to the transmission line (tri-stated). The 485 driver must be controlled unless set to always enabled for RS-422 operation.

Depending on the device circuitry and model, the driver control may be RTS controlled or SD (Automatic Send Data) controlled.

RTS controlled drivers require special software to raise and lower the RTS line on the RS-232 port for each transmission. RTS control is not usually suitable for Windows systems because RTS timing cannot be closely controlled, which can result in lost data.

In SD mode, additional circuitry inside the device controls the transmitter. Some models have a preset fixed R/C timing circuit preset for 9600, or switch selectable presets, or bit-wise enable timing. Serial cards may use bit counters or the UART Transmit buffer status line for control.

In Half Duplex operation, the 485 Driver Control signal is also used to disable receive during transmit, and enable it at the end of transmit.

485 Wires

Two-wire RS-485 system is half duplex using one twisted wire pair plus Signal Ground/Common. The wire pair is used alternately for either transmit or receive by the master or slaves.

Four-wire RS-485 system is full duplex using two twisted wire pairs plus Signal Ground/Common. One pair is used for transmit from master(s) to slaves, the second pair for the slaves to transmit back to the receiver on the master(s). Software flow control can be used since both transmit and receive are active at once.

A

ASCII

American Standard Code for Information Interchange

Asynchronous

Form of serial communication used on personal computer RS-232 ports, RS-485 and most RS-422 communications. No separate synchronizing clock signal needs to be transmitted for the data. This non-synchronous serial communications format uses standard preset baud rates based on a crystal reference for transmit timing, and uses the received data Start Bit and a local crystal reference to read the remaining bits near the center position. Compare to synchronous transmission which requires two synchronizing signals, receive clock and transmit clock plus two data signals.

Automatic Send Data Control

Circuitry found on many RS-485 products which senses the presence of RS-485 data to be transmitted and sets the RS-485 transmitter line driver on to send the data. At the end of transmission, it returns the line driver to a high impedance (disconnected) state. Can also disable the receiver (for Echo Off) during transmit, enable it again at the end of transmission.

B

Bad Node (RS-485)

A device or RS-485 driver/receiver unit which cannot be communicated with. A bad node can be caused by defective wiring or a loss of power (when devices are not tri-stated during power off), or by failure in one device that blocks the data to all the others.

Bar Code Readers / Scanners

Devices used to read bar codes into a computer. Used at Point-of-Sale (POS) checkout counters, for pricing, inventory control, parts tracking, routing or shipping documents.

Baud Rate

In most cases baud rate equals the number of bits per second. However, baud refers to the time period during which one representation of data occurs. In some cases--for example, in modems that use modulation techniques--several bits can be represented during one time period. This makes it possible for the bit rate to be a multiple of the baud rate. For example, if a modem operating at 9600 baud represents four bits of data using quadrature amplitude modulation (QAM), the bit rate can be communicating at a rate of 38,400 bits per second.

Bus

Electrical interconnections in common with other circuits or devices. A power bus provides a common source of power connections, a ground bus, common ground connections for power and/or signal common. A RS-485 bus is the network of wiring joining various RS-485 devices together.

A computer bus provides for internal expansion cards, one of the first commonly used busses was the S-100 bus used on CPM machines. The original IBM personal computer has an 8-bit data bus, the original AT has a 16-bit data bus. These were copied for compatibility with other computers. The PC bus and PC-AT bus interface is now called ISA for Industry Standard Architecture. There are other common busses, including PCI and a variety of industrial busses.

To expand a PCs serial ports or add other functions using a internal card, the type of expansion bus must be known. Check the specifications, verify that the desired bus slot is unused. PCI bus or ISA slots are common in desktops, PCMCIA slots on laptops, USB (Universal Serial Bus) connectors may be available for external expansion on desktops or laptops.

Bus limit

The number of nodes that can be added to a network before a repeater is required, or the maximum number of addresses that can be supported.

C

CD

In RS-232 ports and devices, the CD is the Carrier Detect line from a modem (also called Data Carrier Detect, or DCD). When a modem answers the phone, it looks for the modem carrier, then sets the CD line active when the carrier is present. The computer monitors that line to know when to try connecting or when to hang up if the carrier is lost.

CE

The CE mark indicates compliance with the regulatory requirements of the European Union. All of our products meet the requirements of the US FCC. Those with the CE mark have gone through the additional susceptibility tests required under the European EMC directive.

Channels

- In serial communications a channel is a path for communication. One path is usually transmit, another is receive. Receive and transmit are two channels. RS-232 can have several other channels including the RTS, CTS, DTR, DSR, CD and RI handshake channels. In a multi channel RS-422 converter, each channel uses one twisted pair of wires, and all channels share a common signal ground wire.
- A path of communication or access point for software connection.
- A range of radio frequencies used by a transmitter/receiver during communication or broadcasting or reception. Each channel can be set or preset.

Characteristic Impedance (ohms)

A value based on the inherent conductance, resistance, capacitance and inductance of a cable that represents the impedance of an infinitely long cable. When the cable is cut to any length and terminated with this characteristic impedance, measurements of the cable will be identical to values obtained from the infinite length cable. That is to say that the termination of the cable with this impedance gives the cable the appearance of being infinite length, allowing no reflections of the transmitted signal. If termination is required in a system, the termination impedance value should match the characteristic impedance of the cable.

Converters

A device that converts electrical signals from one format into another. Conversions are electrical, electrical to light (for fiber optical cable), Infrared light or RF.

CTS

Clear To Send - the handshaking line asserted by a DCE device to indicate to a DTE device that it can accept data. The DTE device sets the RTS line, the DCE reads the RTS line to know if the other device can accept data.

D

Data A (RS-485)

The A data line in a half duplex two-wire RS-485 system. Some manufacturers label Data A as Data(-). In an RS-485 two-wire network, Data A is created by connecting the Transmit Data A (TDA) and Receive Data A (RDA) lines.

Data B (RS-485)

The B data line in a half duplex two-wire RS-485 system. Some manufacturers label Data B as Data(+). In an RS-485 two wire network, Data B is created by connecting the Transmit Data B (TDB) and Receive Data B (RDB) lines.

Data Bits

Number of bits per byte. Standard ASCII usually uses 7 data bits. Sometimes 8 data bits are used to accommodate the extended ASCII character set. For example, Modbus ASCII messages use 7 data bits. Modbus RTU messages use 8 data bits.

Data Line Isolation

Isolation between the signal line input and output, and between the signal line common/ground on the input side and output side. Isolation is rated in volts of isolation between all inputs/outputs and signal grounds/commons on one side compared to the other.

Data Lines

The lines that carry digital data in a computer bus or data communications link or network. In serial data systems such as RS-232 the data lines are TD (transmit) and RD (receive). RS-422/485 four-wire networks use two lines: TDA(-)/TDB(+) for transmit, and two lines: RDA(-), RDB(+) for receive. Two-wire RS-485 networks use two bi-directional data lines: DATA A(-) and DATA B(+). Data lines require a signal ground/common to reference the signals. Even differential data lines should be provided with a reference common wire connection.

Data Rates

Supported baud rates in bps (bits per second) or transfer rates for other devices.

DB25

25 pin "D" type connector (looks like a sideways D) The top row has 13 pins (or holes for pins), the bottom row has 12 pins (or holes for pins). If the connector has pins, it is a plug (historically called a male connector); if it has holes to accept pins, it is a receptacle (historically called a female connector).

DB9

9 pin "D" type connector(looks like a sideways D) The top row has 5 pins (or holes for pins), the bottom row has 4 pins (or holes for pins). If the connector has pins, it is a plug (historically called a male connector); if it has holes to accept pins, it is a receptacle (historically called a female connector).

DCE

Data Communications Equipment. A device is considered a DCE if it facilitates communications, as opposed to originating the data to be transmitted. It is important to know whether a piece of equipment is considered a DCE as this determines the pin-out of its RS-232 ports. When connecting a DTE to a DCE, a straight-through serial cable must be used. The straight-through cable connects the DTE's transmitter output to the receiver input on the DCE. When connecting a DTE to a DTE a null modem cable is required. (Null modem cable crosses the pins to connect the Tx on the first DTE to the Rx on the second DTE.

Differential Signaling

Physical signaling method by which a pair of wires is used to transmit a signal. The differential transmitter (+) and (-) outputs are 180 degrees out of phase with each other (when one is +5V, the other is 0 volts, and when the first is 0 volts, the second is +5V). The receiver uses the difference between the two lines to determine the digital state. With differential signals, any induced common mode signals picked up on the twisted pair wires are canceled at the receiver since it sees only the difference signals. Differential signals and common mode rejection help provide reliable serial communication over larger distances than single ended communications.

DIN Rail

A standard metric sized mounting rail for use in a equipment rack or cabinet. Product housings/packages designed to attach to standard sized DIN rails.

Driver Control

In a two-wire RS-485 system, the transmit driver must be enabled to transmit and disabled to receive. (See RTS Control and SD Control)

Drivers

- Hardware drivers provide current or voltages to other hardware devices. The line driver in a RS-485 system is a transmitter that provides voltage and current drive to the receiving devices on the RS-485 network.
- Software drivers provide a standard software interface for a computer Operating System such as Windows, MacOS, UNIX, Linux, SunOS or Solaris.

DSR

Data Set Ready. A RS-232 serial port line which is held high (+3 volts or more) when the data set (DCE device) is turned on and available. This is one of the handshaking lines. A device wanting to communicate with the device (or modem) may check the status of this line to determine if the device is available.

DTE

Data Terminal Equipment. A device that originates data for transmission, such as a computer or serial terminal. The RS-232 DTE or DCE designation determines whether a signal is an input or an output. A DTE device outputs a transmit signal to the transmit input on a DCE device. Although designations are the same, the functions of the signals are reversed between DTE and DCE.

DTR

Data Terminal Ready. An RS-232 serial port line which is held high (+3 volts or more) when the terminal is turned on and available. This is one of the handshaking lines. A device wanting to communicate with the terminal may check the status of this line to determine if the device is available.

E

Earth Ground

A ground that directly connects to the earth through grounding stakes and buried copper wire or metal water pipes buried in the earth. Usually some form of earth ground is provided at the entry point of phone lines or AC power. The power ground within a building can vary from earth ground, and earth grounds at different locations can have voltage differences between them, especially during electrical storms.

Echo Off

- In a half duplex two-wire RS-485 system, the receiver is normally disabled during transmit, so the data is not echoed back to the receiver even though the receiver inputs are connected to the transmitter outputs. An Echo Off switch or jumper (if provided) can set the receiver mode so that transmitted data is not fed back to the receiver. It sets the receiver for two-wire RS-485 mode.
- A communications terminal program may depend on the remote terminal to echo the characters typed locally. If the program displays the typed characters, and they are echoed by the remote device, each character is repeated. The Echo off setting turns off local echo so only the returned characters are displayed. The reverse case is that the remote terminal does not return typed characters, and the user cannot see what he/she is typing. Then echo must be set on locally.

Echo On

- In a half duplex two-wire 485 system, the receiver is normally disabled during transmit, so the data is not echoed back to the receiver even though the receiver inputs are connected to the transmitter outputs. An Echo On switch or jumper (if provided) can set the receiver mode so that it is enabled all the time, and transmitted data is returned to the receiver. Echo on can be used in two-wire mode, but since the setting enables the receiver all the time, this setting is typically used in four-wire RS-485 and RS-422 modes.
- A communications terminal program may depend on the remote terminal to echo the characters typed locally. If the program does not receive the

characters back, the user does not know what is being typed. The Echo On setting turns on local echo so that typed characters can be viewed. If they are echoed by the remote device, each character is repeated. If typed characters are repeated twice for each character typed, local echo should be set Off.

EMI/RFI

Electro Magnetic Interference/Radio Frequency Interference: signals generated by expanding/collapsing magnetic fields such as motors, transformers, arc welding, fluorescent/neon lighting, radio/television Transmitters, motor brushes, lightning.

EMI/RFI Immunity

The level at which a device or signal is unaffected by EMI/RFI

Externally Powered

- Requires connection of a power source such as AC or DC. The required power source is rated for the type of voltage in volts (VAC or VDC), and the required current in mA (milli-Amps), A (Amps) or VA (Volt-Amps)/Watts.
- A externally powered converter that does not support Port Power must obtain power though connection terminals, a DC jack or connector pins. Isolated converters may require port power for the RS-232 side, a power supply for the RS-422/485 side.

F

Female (Connector)

Connector which has a receptacle socket (holes) for pins. When F follows the connector type, the connector is a female connector.

Flow Control

The process of managing the rate and direction of data transmission between two nodes.

Four-wire (RS-422/RS-485)

A full duplex system uses one twisted pair (TDA(-) & TDB(+)) for transmitting, a second twisted pair (RDA & RDB) for receiving, plus a Signal Ground/Common.

In a RS-422 system, there are normally two units (master-master or master-slave), or one master with multiple listeners which do not transmit back.

In a Four-wire RS-485 system, there can be one or more masters, talking to multiple slaves. Each slave must be addressable and have RS-485 transmitter enable (as in Two-wire). A single master multi-slave system is sometimes called "half-422" because the master is set for RS-422 operation, but the slaves must be set for 485 transmit.

Full Duplex

A full duplex communications system is able to transmit and receive at the same time. Two communications paths are provided, one for each direction. Examples are RS-232, RS-422 and Four-wire RS-485. (Two-wire RS-485 is half duplex)

G

Ground Loops

When two or more devices are connected to a common ground through different paths, a ground loop occurs. Currents flow through these multiple paths and develop voltages which can cause damage, noise or 50Hz/60Hz hum in audio or video equipment. To prevent ground loops, all signal grounds need to go to one common point and when two grounding points cannot be avoided, one side must isolate the signal and grounds from the other.

Grounding Strap

- A heavy solid or braided wire cable used to provide a low resistance path from a device to a earth ground. Used with surge suppressors.

- A conductive wrist strap and grounding cord used to discharge static voltages to ground when handling ESD (Electro Static Discharge) sensitive devices such as interface cards.

H

Half Duplex

In a half duplex communications system a device can either receive or transmit, but not both at the same time. Many radio transmission systems are half duplex because the transmitter and receiver use the same frequency, and while transmitting mute the receiver. A RS-485 two-wire system is also half duplex because it uses the same pair of wires to transmit and receive.

Handshake Lines

In an RS-232 serial system, data flow control is performed using the CTS (Clear To Send) and RTS (Request To Send) control lines. The DSR (Data Set Ready) and DTR (Data Terminal) control lines are used to determine if a device is connected and active. Additional lines for DCD/CD (Carrier Detector) and RI (Ring Indicator) are used with modems.

Handshaking

The process of using handshaking lines or software data flow control such as X-On/X-Off to transfer each byte of data.

Hardware Flow Control

- Serial Port transfer using the RTS and CTS control lines to control data flow instead of using software flow control using X-On/X-Off control with a full duplex serial link.
- Parallel data transfer in which handshaking for each data byte is handled automatically by the hardware rather than by computer instructions that alter each of the 4 hardware states

Hardware Handshaking

Serial Port transfer using the RTS and CTS control lines to control data flow instead of using software flow control using X-On/X-Off control with a full duplex serial link.

I

Interface

- The connection between computer and the outside world. Electrical interfaces can be serial, RS-232, RS-422, RS-485, USB-A Female, Parallel, or similar.
- A user interface provides a connection between the user and program. It includes the appearance of the screens, menus, mouse/keyboard keys for input/output. Windows provides standard methods for a program to use to build a user interface.

Interface Converter

A converter from one type of interface to another. A converter performs conversion from one electrical format to another. RS-232 to RS-422 or RS-485 or back, RS-232 to fiber optic or back. Some converters handle hardware conversion between formats. Some require hardware and software to perform conversion. For example, Host USB to RS-232/422/485 or Ethernet to Serial.

Compare a converter to an adapter. An adapter simply converts hardware connections, whereas a converter may also provide an electrical signaling change. A RS-232 signal may use DB25, DB9 or RJ-11 or phone plug or jack. The signal connector is adapted, not converted.

Isolation

Separation of all electrical signals and ground on one device from those on another device. Isolation is usually rated in volts or leakage currents. Isolated power is typically handled by power transformers and separate power supplies with no common between one side and the other. Signal lines may be isolated with signal transformers (depending on the signal), optical isolators, or with fiber optic converters.

L

LED

Light Emitting Diode - a semiconductor device that emits light when forward biased. An LED may be infrared, red, green or yellow. Some package incorporate two colors. LEDs are often used as a solid state replacement for bulb indicator lamps. Forward voltage drop is typically 1.9-2.4 volts, making them suitable indicators when used with a current limiting resistor for low current TTL indicators or RS-232 signal indicators.

M

Male (Connector)

The connector which has the plug portion or pins which fit a female receptacle or socket. The plug which inserts into a jack. Usually M after the connector type indicates a Male connector.

Many products such as printers place the female socket on the device so that if a pin breaks or is bent on a cable, the cable is more easily replaced than the connector built-in to a device. The exception is RS-232 serial connectors, which are male to avoid confusion with the female DB9 video connector and female DB25 printer connector.

Master (Device)

The master in a network controls all the other devices (slave devices) attached to the network. The master sends commands to request data, the slaves respond with data. Some slave devices may prefix their response with an identifying header.

Master-Slave

A command/response relationship between two devices where one device sends commands and requests data (Master). The other device only responds to the commands (Slave), and does not initiate conversation.

Max Baud Rate

Maximum baud rate supported by the hardware (electronics circuitry)

Mbps

Mega bits per second. A data rate in million bits per second

Modbus

Modbus is a serial communications protocol published by Modicon in 1979 for use with its programmable logic controllers (PLCs). It has become a de facto standard communications protocol in industry, and is now the most commonly available means of connecting industrial electronic devices. The main reasons for the extensive use of Modbus over other communications protocols are:

1. It is openly published and royalty-free
2. Relatively easy industrial network to deploy
3. It moves raw bits or words without placing many restrictions on vendors

Modbus allows for communication between many devices connected to the same network, for example a system that measures temperature and humidity and communicates the results to a computer. Modbus is often used to connect a supervisory computer with a remote terminal unit (RTU) in supervisory control and data acquisition (SCADA) systems.

Modbus Gateway

Protocols are like languages, French, English, Spanish, or Japanese. If devices are to understand each other, they must speak the same language, similar to using a phone, otherwise a translator is needed. Interfaces such as RS232, RS422, RS485, or Ethernet only define the electrical interface. ModBus has several dialects, ASCII, RTU or Modbus/TCP. A Modbus Gateway like the Vlinx MESR series bridges between ModBus protocols, enabling communications between Modbus devices speaking different dialects. Protocol Gateways like our Connect Pro can translate between more than 100 different protocols, enabling a device using one protocol to access data in a different protocol and

electrical interface. Gateways also solve other connectivity problems, like allowing multiple "master" devices to access and share data.

Multidrop

- Multiple devices at various locations connected in parallel or acting similar to parallel devices.
- A RS-485 network (Two-wire or Four-wire) with multiple devices in parallel at various locations.

Multi-master protocol

A protocol that employs polling sequence breaks, to allow multiple devices to request the bus or request service. Typically this is an empty time frame after which a device may put its address on the bus, be acknowledged with a device ID.

N

Node (RS-485)

Each driver/receiver pair on a RS-485 bus is a node on the network. Up to 32 nodes can be connected in parallel before adding a repeater. One repeater equates to two nodes, one on each side.

Non-Isolated

A device or converter that has signal grounds or power sources in common between the input and output sides or between the RS-232 and RS-232/422/485 sides.

Null Modem

A null modem cable or connector permits two similar RS-232 Devices (wired as DTE or DCE) to be connected together so that the outputs of one device are routed to the inputs of the other device. At a minimum, the Transmit Data (TD) of one device is routed to the Receive Data (RD) of the other, and the TD of the second device to the RD of the other, and the ground lines are

interconnected. Various configurations are available (See 232MFNM Data Sheet).

RS-232 devices may require DSR cross connected to DTR, and to CD, and RTS to CTS. (note that a regular MODEM cable has connections to the same pins on both sides)

O

Optical Isolation

Electrical isolation provided by converting the electrical signal to light, then converting the light back to electrical signal. The optical isolator consists of a light emitting diode and phototransistor in one package. This is a better method of providing circuit isolation for some types of signals than by using signal transformers, radio frequencies or surface wave/acoustic isolators.

P

Parity Bit

A binary digit that is added to ensure that the number of bits with value of one in a given set of bits is always even or odd. It may also be a Mark (1), or a Space (0).

Pinouts

A labeled figure or numbered list/diagram showing pin layout/index or which shows the signal name and pin number for each connection to a device. The pinouts on a device help technicians to wire connectors or cables and to make the proper signal connections (or omit connections) between devices. Pinouts on many devices such as RS-422 or RS-485 are non-standard, so diagrams are usually needed unless the connection copies a widely accepted product such as the parallel printer Centronics connections on a printer (some may be added or omitted), or the IBM PC printer connector (DB25F), or the RS-232 DB25M (PC) or DB9M (PC/AT).

PLC

Programmable Logic Controller. A microprocessor controlled device that locally controls some process and usually connects serially to another device or network of other devices. Usually includes a RS-232, RS-422 or RS-485 serial connection.

Plenum cable

Plenum rated cable is fire resistant and less toxic when burning than non-plenum rated cable. Check building and fire codes for requirements. Plenum cable is generally more expensive due to the sheathing material used.

Plenum Rated

Rating for cable which is fire resistant and less toxic when burning than non-plenum rated cable.

Point-to-Point

Communication from one device at one location to another device at a second location. Two devices rather than multi-drop devices.

Port

- Electrical interface on a computer or device which permits connection to another device. Usually, Serial/RS-232, Parallel Printer, Video/VGA/SVGA, SCSI, Keyboard, IR, USB, Audio, Firewire, Joystick/Trigger/Game/Controller, Mouse, Ethernet, PCMCIA, Telephone Modem, or Cellular Modem port.
- Electrical connection on a microprocessor that permits the processor to read inputs or control outputs.

Port Power

- USB device that obtains power from the USB port power lines.
- A serial/fiber optic/parallel converter which obtains operating power from the input signals and handshaking lines. It 'steals' power from the device to which it is connected so that it can power it's own low power circuitry.

Port Powered Converters

A serial/fiber optic/parallel converter which obtains its operating power from the input signals and handshaking lines. In Serial Converters, TD, DTR, RTS or the DTR/DSR and RTS/CTS/CD pairs. The necessary lines must be present and connected, they must provide enough voltage (6-7 volts) when loaded, some models require positive voltages on RTS and DTR, others use either positive or negative voltages.

Propagation velocity (% of c)

The speed at which an electrical signal travels in the cable. The value given typically must be multiplied by the speed of light (c) to obtain units of meters per second. For example, a cable that lists a propagation velocity of 78% gives a velocity of $0.78 \times 300 \times 10^6 = 234 \times 10^6$ meters per second.

Protocol

The rules used in communicating between nodes on a network. Includes the sequence of data requests, return data values, command set and other standardized aspects of sending messages.

R

RD

Receive Data line in an RS-232 interface.

RDA(-)

Receive Data line A. One of two differential receive lines in RS-422 or Four-wire RS-485 connections. The (-) line which is low compared to the (+) B line during the Mark/Inactive state.

RDB(+)

Receive Data line B. One of two differential receive lines in RS-422 or Four-wire RS-485 connections. The (+) line which is high compared to the (-) A line during the Mark/Inactive state.

Receptacle

A female (socket/jack) connector that accepts pins

Repeater

A device which receives input in one format and restores the signal to standard levels. May be for RS-232, RS-422, RS-485 or fiber optic signals. Repeaters are used to increase the number of devices connected to a RS-485 network or to increase the connection distance by strengthening signals weakened by long transmission distances (over 50 ft. for RS-232 or 4000 ft for RS-422 or RS-485 communications).

RJ-11

A modular telephone style four-contact connector. Usually male on the connecting cord, female on devices. The center four positions have contacts similar to a residential telephone or telephone modem. This is a connector type only. Devices that use this connector are not necessarily designed for connection to telephone company phone or data lines. RJ-11 connectors have been used on some RS-485 systems.

RJ-12

A modular telephone style six-contact connector. Usually male on the connecting cord, female on devices. The center four positions have contacts similar to a residential telephone or telephone modem. This is a connector type only. Devices that use this connector are not necessarily designed for connection to telephone company phone or data lines. RJ-12 connectors have been used on some RS-485 systems.

RJ-45

A modular telephone style eight-contact connector. Usually male on the connecting cord, female on devices. The center four positions have contacts similar to a residential telephone or telephone modem. This is a connector type only. Devices that use this connector are not necessarily designed for connection to telephone company phone or data lines. RJ-45 connectors have been used on some RS-485 systems.

RS-232

RS-232 provides serial connections using single ended signals, which may vary between -3 to -25 volts to +3 to +25 volts.

Minimal signals for bi-directional communication are signal ground/common, Transmit (Tx) and Receive (Rx) Data or TD and RD. IBM PC compatible RS-232C ports provide handshaking lines, DSR and DTR and flow control handshaking lines, CTS and RTS. Modem control lines for RI (Ring Indicator) and CD (Carrier Detector) are supported. Data is transferred serially using Asynchronous data, with a start bit, data bits, stop bit/bits.

Flow control can be performed by software using X-On/X-Off, or by hardware handshaking if available.

RS-232 Connector

This is the connector used on the RS-232 side of the converter or a RS-232 device. The EIA-232 standard specifies a DB-25 connector but DB-9 connectors are commonly used.

RS-232 Port

A electrical connector that provides some or all of the RS-232 signal lines. Unless a device is transmit or receive only, a RS-232 port will provide at least signal ground/common and RD & TD.

RS-232/RS-422/RS-485 Fiber Optic Conversion

A fiber optical converter which has dual interfaces can be set to convert from RS-232 to fiber optic at one end and from/to RS-422 or four-wire RS-485 or

Two-wire RS-485 at the other end. If using for two-wire RS-485, the devices must be suitable for half duplex operation.

RS-422

A standard used to extend serial communications up to 4000 ft. between two devices. Each channel of communications is converted to a differential signal and carried on a twisted wire pair so that when the differential signal is received, common mode noise is rejected. RS-422 generally has at least two channels, receive and transmit. These are carried on four wires, and a signal common/ground provides a reference for the receiver and transmitter. RS-422 can also handle handshaking signals using additional twisted pairs.

RS-422 Connector

This is the connector type used on the RS-422 side of a converter or device. The EIA-422 standard does not specify a connector to be used with RS-422. In actual products a variety of connectors are used.

RS-422 Port

A serial port which provides RS-422 differential inputs for receive and outputs for transmit. Typical RS-422 ports support two channels.

RS-422 Transmit Enable

Some RS-422 devices can have the transmit driver enabled and disabled as is done for RS-485. Disabling the transmitter when not used saves power on port powered devices. It also allows a RS-422 device to operate as in a four -wire "half 485" mode, the same as a four-wire RS-485 device.

Normal RS-422 devices have the transmitter enabled all the time. Controlled transmitters are activated by setting the RTS line in the RS-232 device or the RTS control in the UART. When the RTS line is not asserted, the transmitter is set Off to a high impedance state.

RS-485

RS-485 is a multi-drop extension to the RS-422 standard. It uses differential signals on twisted pairs for receive and transmit.

RS-485 systems can be half duplex two-wire systems (one twisted pair plus signal common/ground) or full duplex four-wire systems. An RS-485 transmitter driver is activated to send data and is set to a high impedance tri-state at the end of transmission. Driver control can be automatic using a Send Data circuit, or manual by setting the RTS line or UART RTS control high for transmit, then low at the end of transmission. In a half duplex two-wire system, the receiver is set to receive except when transmitting.

In a two-wire system, all slaves and masters are normally in the receive mode. When one master transmits, all slaves and masters receive the signal and response, and all slaves must be able to ignore commands and responses to/from other slaves. Each slave must wait until transmit is finished plus a delay (for bus turn-around), before responding.

In a four-wire system, all slaves are connected to the transmitter of the master(s). All slaves connect to the receiver of the master(s). Each slave must respond only to commands addressed to it, but no turn-around delay is needed. The slave can start responding immediately, even while receiving. Other slaves never hear each other's responses.

RS-485 Connector

This is the connector used on the RS-485 side of the converter or device.

RS-485 Fail-Safe Port Isolator

A device intended for use in a RS-485 network to isolate a node which has become stuck in a MARK or SPACE state or which has lost power and is loading down the rest of the 485 network so other devices cannot be accessed. When a node stops working, the port isolator disconnects it from the remainder of the network.

RS-485 Network

The RS-485 wiring and slave devices interconnected to one or more masters. From a hardware point of view the number of devices on a RS-485 network is restricted to 32 nodes unless repeaters are used. From a software point of view the number of nodes is only restricted by the addressing scheme of the devices, typically 255 for a single byte address.

RS-485 Port

Electrical connections that provide two-wire half duplex RS-485 signals or four-wire full duplex RS-485 signals.

RTS

Request To Send. An RS-232 port handshaking line that is typically asserted (raised high) to notify another device that the asserting device would like to transmit data. Is also used in some applications to indicate that the asserting device is ready to accept data.

Some RS-422 and RS-485 Converters use RTS to enable transmit when Asserted (RTS High), and in two-wire RS-485 systems to disable receive. When RTS is low, receive is enabled, transmit is tri-stated off. Special software is required to use RTS control.

RTU

Remote Terminal Unit

S

SCADA

Supervisory Control And Data Acquisition. It generally refers to an industrial control system: a computer system monitoring and controlling a process. The process can be industrial, infrastructure or facility based as described below.

Send Data (SD)

Automatic Send Data control. Circuitry for a RS-485 transmit line driver which enables the transmit driver for transmit, then returns the transmit driver to a high impedance tri-state at the end of transmission.

Serial Connector

The connector used for serial connections to/from a device is typically a standard type of DB9 or DB25, but various connector types may be used, RJ-11/RJ-12, 8-pin DIN, RJ-45 or DB37.

Common serial ports are RS-232, but RS-422 or RS-485 ports are available using expansion cards or converters.

A USB port is serial, but is generally called a USB port, for Universal Serial Bus since the port provides for external system expansion rather than internal expansion using ISA or PCI bus. USB is a host/device bus, not a device/device serial connection.

Serial Port

Usually a RS-232C serial port, but may be RS-422 or RS-485 connections. The electrical connections to a computer or device.

In a serial port, a byte of data is transmitted or received one bit at a time. Typical eight-bit data requires that 10 bits be transferred, one bit at a time. In a eight-bit parallel port, data is transferred eight bits at once.

A USB port is a special type of host computer serial port. USB devices can communicate with the host, but not with each other.

SG / Signal Ground

Signal Ground (SG) is the signal common for a serial or similar connector. Single ended signals are referenced the common, and differential signal receivers require the common reference to establish the common level between transmitter and receiver. Signal Ground may be isolated from the grounds on other devices or may be connected by some device or devices to earth or AC mains ground. Signal Ground may be used as a reference to the (-) minus side of a power supply.

Simplex Mode

Operating single direction or half duplex. A single fiber optic cable is a simplex cable.

Slave (Device)

A device which responds to commands by performing some action or returning data. A slave does not send data until data is requested.

Smart Switch

A device that allows you to control or monitor multiple serial devices with a single port. Sometimes called a "code activated switch" or "sharer"

Software Controlled

A software controlled device must be controlled by custom software that specifies that particular device or the customer/engineer must provide for custom programming that controls the device according to application needs.

Stop Bit

Number of bit times after a character is transmitted before the next character can start transmission.

Suppression

Suppression limits the voltage on the input lines. Suppression attempts to clamp or conduct voltages between lines on one side of the suppressor. High voltages and heavy currents may exceed the rating of the device, causing it to short or open, which is one reason some current limiting may be provided by fuse or resistance. The suppressor may become faulty while attempting to protect, so it may need to be replaced after a heavy surge or lightning.

Surge

A abnormal current or voltage that exceeds the normal maximum rating of a device.

Surge Protection

Protection of a device from abnormal currents or voltages so that it is not damaged, and will be likely to operate normally after the short term condition ceases.

Surge Suppressor

A device which suppresses voltage or current surges on serial data lines, AC input power lines, telephone/facsimile lines, or antenna/cable TV lines.

Switching Power Supply

A power supply that operates by turning off/on rapidly (switching) to convert DC to AC at some frequency (usually 15.734KHz or less) that can use a small core transformer. The AC is then rectified back to DC. The DC voltages on the secondary side may provide feedback to the primary side for voltage regulation. The transformer provides isolation. Optical feedback isolates the secondary side from the primary side. A switching supply for AC line power usually converts the AC to DC before converting it back to higher frequency AC, then DC. Many AC supplies are designed for Worldwide power and handle 240/220/120/100 VAC at 50/60Hz.

A DC/DC converter is a switching supply.

T

TD

Transmit Data. The data Output line on a computer/DTE device, the input line on a modem/DCE device.

TDA(-)

The (-) line in a RS-422 (or four-wire RS-485) transmit pair. This line is negative relative to the TDB(+) line during a idle or MARK state.

TDB(+)

The (+) line in a RS-422 (or four-wire RS-485) transmit pair. This line is positive relative to the TDA(-) line during a idle or MARK state.

Terminal Blocks

Connection terminals which provide electrical contacts for tinned stripped wires, with some means of tightening or loosening the connection to the wires. Terminal blocks typically have a hole to insert the wire, and a screw to tighten/secure it. The hole can usually accept one or two wires. Some surge protection devices use a terminal strip, usually called a barrier strip. It accepts wires with a three-quarter wrap around the screw or lug.

Termination

Connecting a resistance at one or both ends of a cable to prevent reflections is called termination. The proper termination resistance is equal to the characteristic impedance of the cable. Reflections traveling up/down the line can alter the signal and cause data errors.

Typical RS-422/RS-485 cables may require a 120 ohm termination at each end of a cable run if reflections cause a problem. Termination (when needed) is normally installed on the receivers at each end. Some converters/cards provide selectable termination using a jumper or switch, others provide extra terminals in parallel for connection of termination.

Common termination values for electronic devices varies by the type of device, 75 ohms for video or RF antenna, 300 ohms for twin lead, 50 ohm for coax, and other values of pull-up/pull-down termination for SCSI bus devices.

Transceiver

A combination transmitter and receiver. Sometimes used to refer to an RS-485 driver and receiver device combination when bridged (internally or externally) to transmit and receive on the same communications line.

Also used to describe a radio transmitter/receiver combination.

Tri-state

An output that can assume any of three states. Two states are normal low-impedance: logic 1 or logic 0. The third state is a high-impedance, or off,

state. In the high impedance state the output is effectively open circuit and does not apply either logic state, allowing other outputs connected to the same output lines to share the media.

TVS (Transient Voltage Suppressor)

A device that suppresses voltages by conducting either positive or negative voltages above the threshold voltage from one terminal to the other. Electrically, a TVS works like back-to-back Zener diodes.

Twisted Pair Cable

A cable for serial communication which includes at least one twisted pair of two wires. May be shielded or may provide a separate ground wire. Twists in the wire provide noise cancelation as noise is induced on the lines in series opposing causing it to cancel out.

Two-wire (RS-485)

A half duplex RS-485 connection system which uses one twisted pair for Data A(-) and Data B(+), plus Signal Ground/Common.

Transmit and receive operations are on the same pair of wires, allowing all devices on the bus to communicate with each other. The system requires that each slave have a turn-around delay of one or more characters between receiving data and responding. Each device must be separately addressable, and ignore data/commands that do not apply to the device's address. All Two-wire RS-485 devices are normally in receive mode except when transmitting. Receivers can either be disabled or enabled when the device is transmitting. Disabling the receiver prevents an echo of the sent characters from being received on the sending device (Echo off). Alternately, the sending device may leave its receiver enabled to detect any collisions from other devices on the bus (Echo on). Driver/Receiver control can either be implemented through software in the node or through hardware. B&B converters and serial cards offer this option through either the RS-232 RTS line for software control or Automatic Send Data (SD) control in hardware.

Tx

Transmit or transmitter. When Morse code was used, the letter X was commonly keyed rather than the full word, Tx rather than transmitter, xmit rather than transmitter xceiver rather than receiver or Rx for receive/receiver. Sometimes used as a label for transmit line pinouts. (TD also used for the same purpose.)

U

Unbalanced Signal

Single-ended signal referenced to ground or common. Noise/hum picked up cannot be canceled, often requires shielding. Compare to differential or balanced outputs or inputs. In balanced signals, the outputs are 180 degrees out of phase, in-phase common mode noise is canceled in the receiver.

USB (Universal Serial Bus)

Universal Serial Bus. A limited range high speed serial bus standard used to expand or add functionality to a host computer. Permits connecting peripheral devices such as hard drives, printers, scanners, optical drives, real time video/audio devices or legacy serial or printer ports.

Requires drivers for the host operating system or requires that the OS provide compatible drivers as part of the system software. Separate drivers usually required for MacOS or Windows OS.

USB Hub

A USB host port expander that enables connection of more USB devices (up to 128 total) to a host USB port. Expansion is usually three or more ports.

V

Vcm

Common mode voltage. Voltage (with respect to ground) that is common to both inputs of a balanced device input. If Vcm is greater than the device's specified maximum value, the device could be damaged.

VDC

Volts DC. Steady state voltage.

Voltage Spikes

A transient, very short term high voltage on a signal or power line.

Index

4

485 Driver Control • 99

485 Wires • 99

A

AC Termination • 32

ASCII • 100

Assumptions • 6

Asynchronous • 100

Attenuation vs Frequency • 46

Automatic Send Data Control • 100

B

Bad Node (RS-485) • 100

Balanced Data Transmission • 11

Bar Code Readers / Scanners • 101

Baud Rate • 101

Biasing an RS-485 Network • 20, 32

Bidirectional Termination • 30

Bit-wise Enable Timing Control • 20

Bit-Wise Enable Timing Diagrams • 21, 97

Bus • 101

Bus limit • 101

C

Cable Characteristics • 45

Cable Length vs Data Rate • 45

CD • 102

CE • 102

Channels • 102

Characteristic Impedance (ohms) • 102

Choosing the right protection for your system • 62

Combining Isolation and Shunting • 60

Common Mode versus Differential Mode • 52

Common Mode Voltage • 14

Comparison of RS-232, RS-423, RS-422 and RS-485 Specifications • 87

Connecting Signal Grounds • 59

Converters • 103

CTS • 103

D

Data A (RS-485) • 103

Data B (RS-485) • 103

Data Bits • 103

Data Line Isolation • 104

Data Lines • 104

Data Rates • 104

Data Transmission Signals • 8

DB25 • 104

DB9 • 104

DCE • 105

Deciding whether to use termination • 28

Differential Signaling • 105

DIN Rail • 105

Driver Control • 105

Drivers • 105

DSR • 106

DTE • 106

DTR • 106

E

Earth Ground • 106

Echo Off • 107

Echo On • 107

EIA Specification Summary • 85

EIA Standard RS-423 Data Transmission •
10, 89

EIA-232 Specifications • 86

EIA-422 Specifications • 85

EIA-423 Specifications • 87

EIA-485 Specifications • 86

EMI/RFI • 107

EMI/RFI Immunity • 108

Example 1

 Biasing when termination resistors are
 used • 34

Example 2

 Biasing when termination resistors are
 not used • 36

Example calculation to determine whether
termination is necessary • 29

Externally Powered • 108

F

Female (Connector) • 108

Flow Control • 108

Four Wire Master-Slave Systems • 68

Four-wire (RS-422/RS-485) • 108

Four-Wire Systems • 27

Full Duplex • 109

G

Global Engineering • 81

Ground Loops • 109

Grounding Strap • 109

H

Half Duplex • 109

Handshake Lines • 110

Handshaking • 110

Hardware Handshaking • 110

I

Integrated Circuit Manufacturers • 82

Interface • 110

Interface Converter • 111

Isolation • 111

Isolation Devices • 57

Isolation Theory • 55

L

LED • 111

List of EIA/TIA Standards • 82

M

Male (Connector) • 112

Master (Device) • 112

Master-Slave • 112

Master-Slave Systems • 68

Max Baud Rate • 112

Mbps • 112

Methods of Termination • 25, 29

Modbus • 112

Modbus Gateway • 113

- Multidrop • 113
- Multi-master protocol • 114
- Multi-Master RS-485 Systems • 70
- N**
- Network Topologies • 25
- Node (RS-485) • 114
- Non-Isolated • 114
- Null Modem • 114
- Number of Conductors • 43
- O**
- Optical Isolation • 115
- Optically Isolated RS-422/485 Devices • 79
- Other Biasing and Terminating Considerations • 38
- Other sources of information • 83
- Other Tri-State Control Techniques • 21
- Overview • 5
- P**
- Parallel Termination • 30
- Parity Bit • 115
- PC Serial Interface Cards • 75
- Pinouts • 115
- PLC • 115
- Plenum cable • 116
- Plenum Rated • 116
- Point-to-Point • 116
- Port • 116
- Port Power • 116
- Port Powered Converters • 77, 116
- Propagation velocity (% of c) • 117
- Protocol • 117
- R**
- RD • 117
- RDA(-) • 117
- RDB(+) • 117
- Receptacle • 117
- Repeater • 118
- Repeaters • 77
- RJ-11 • 118
- RJ-12 • 118
- RJ-45 • 118
- RS-232 • 119
- RS-232 Connector • 119
- RS-232 Port • 119
- RS-232 to RS-485 Converters • 74
- RS-232/RS-422/RS-485 Fiber Optic Conversion • 119
- RS-422 • 119
- RS-422 and RS-485 Terminals and Designations • 13
- RS-422 Connector • 120
- RS-422 Point-to-Point Connections • 24
- RS-422 Port • 120
- RS-422 Systems • 66
- RS-422 Transmit Enable • 120
- RS-485 • 120
- RS-485 Connector • 121
- RS-485 Devices • 73
- RS-485 Driver Control • 66
- RS-485 Fail-Safe Port Isolator • 121

- RS-485 Network • 121
- RS-485 Port • 121
- RS-485 Receiver Control • 68
- RTS • 122
- RTS Control • 17
- RTS Control Timing Diagrams • 18, 95
- RTU • 122
- S**
- SCADA • 122
- Selecting RS-422 and RS-485 Cabling • 43
- Selecting RS-485 Devices • 91
- Send Data (SD) • 122
- Send Data Control • 17, 18
- Send Data Control Timing Diagrams • 20, 96
- Serial Connector • 122
- Serial Port • 123
- SG / Signal Ground • 123
- Shielding • 44
- Shunting Devices • 59
- Shunting Theory • 57
- Simplex Mode • 123
- Slave (Device) • 123
- Smart Switch • 124
- Software • 26, 65
- Software Controlled • 124
- Sources of Additional Information • 81
- Special Consideration for Fault Conditions • 62
- Stop Bit • 124
- Suppression • 124
- Surge • 124
- Surge Protection • 124
- Surge Specifications • 50
- Surge Suppressor • 124
- Switching Power Supply • 125
- System Configuration • 12, 23
- Systems with Port Powered Converters • 71
- T**
- TD • 125
- TDA(-) • 125
- TDB(+) • 125
- Terminal Blocks • 125
- Termination • 27, 126
- Termination to Reduce Noise • 32
- Testing and Troubleshooting RS-422/485 Systems • 91
- Transceiver • 126
- Transient Protection of RS-422 and RS-485 Systems • 15, 49
- Transient Protection using Isolation • 55
- Transient Protection using Shunting • 57
- Tri-state • 126
- Tri-State Control • 16, 67
- Troubleshooting Checklist • 92
- Troubleshooting Flowchart • 93
- TVS (Transient Voltage Suppressor) • 127
- Twisted Pair Cable • 127
- Two Wire Master-Slave Systems • 70

Two-wire (RS-485) • 127

Two-Wire Systems • 25

Tx • 127

U

Unbalanced Data Transmission • 9

Unbalanced Signal • 128

USB (Universal Serial Bus) • 128

USB Hub • 128

USB to RS-422/485 Converters • 76

Using Cat 5 for RS-422/485 • 47

Using Fractional Load Receivers to Extend
Distance and Number of Nodes • 42

Using Repeaters • 39

Using Repeaters in a Master-Slave Network
• 40

Using Repeaters in Star, Ring and Tree
Networks • 41

V

Vcm • 128

VDC • 128

Voltage Spikes • 129

W

What does a surge look like? • 49

What is RS-422/RS-485? • 6

When Ground is not really Ground • 53