

Methods in
Molecular Biology 1060

Springer Protocols

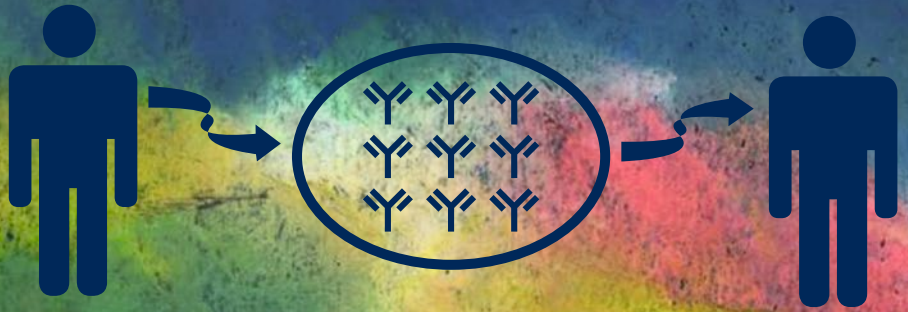

Michael Steinitz *Editor*

Human Monoclonal Antibodies

Methods and Protocols

 Humana Press

METHODS IN MOLECULAR BIOLOGY™

Series Editor
John M. Walker
School of Life Sciences
University of Hertfordshire
Hatfield, Hertfordshire, AL10 9AB, UK

For further volumes:
<http://www.springer.com/series/7651>

Human Monoclonal Antibodies

Methods and Protocols

Edited by

Michael Steinitz

*Department of Pathology, The Lautenberg Center, IMRIC, The Hebrew University,
Hadassah Medical School, Jerusalem, Israel*

 **Humana Press**

Editor

Michael Steinitz
Department of Pathology
The Lautenberg Center, IMRIC
The Hebrew University
Hadassah Medical School
Jerusalem, Israel

ISSN 1064-3745 ISSN 1940-6029 (electronic)
ISBN 978-1-62703-585-9 ISBN 978-1-62703-586-6 (eBook)
DOI 10.1007/978-1-62703-586-6
Springer New York Heidelberg Dordrecht London

Library of Congress Control Number: 2013943914

© Springer Science+Business Media, LLC 2014

This work is subject to copyright. All rights are reserved by the Publisher, whether the whole or part of the material is concerned, specifically the rights of translation, reprinting, reuse of illustrations, recitation, broadcasting, reproduction on microfilms or in any other physical way, and transmission or information storage and retrieval, electronic adaptation, computer software, or by similar or dissimilar methodology now known or hereafter developed. Exempted from this legal reservation are brief excerpts in connection with reviews or scholarly analysis or material supplied specifically for the purpose of being entered and executed on a computer system, for exclusive use by the purchaser of the work. Duplication of this publication or parts thereof is permitted only under the provisions of the Copyright Law of the Publisher's location, in its current version, and permission for use must always be obtained from Springer. Permissions for use may be obtained through RightsLink at the Copyright Clearance Center. Violations are liable to prosecution under the respective Copyright Law.

The use of general descriptive names, registered names, trademarks, service marks, etc. in this publication does not imply, even in the absence of a specific statement, that such names are exempt from the relevant protective laws and regulations and therefore free for general use.

While the advice and information in this book are believed to be true and accurate at the date of publication, neither the authors nor the editors nor the publisher can accept any legal responsibility for any errors or omissions that may be made. The publisher makes no warranty, express or implied, with respect to the material contained herein.

Printed on acid-free paper

Humana Press is a brand of Springer
Springer is part of Springer Science+Business Media (www.springer.com)

Preface

There is no doubt that the introduction of monoclonal antibodies revolutionized immunology. The ease and reproducibility of the various techniques for preparing murine monoclonal antibodies, using both cellular and molecular techniques, have had a major impact on their rapid and comprehensive expansion. The development of human monoclonal antibodies has been inspired primarily by the enormous clinical benefits promised by these reagents, used as anti-inflammatory reagents, anti-tumor reagents, and reagents for passive immunization. Initially, some technical and ethical obstacles hampered the development of entirely human monoclonal antibodies, prompting the development of chimeric and humanized monoclonal antibodies. The development of an immune response against the mouse residual fragment in these antibodies stressed the need for complete human antibodies. Today, the development of advanced cellular and molecular techniques enables the production of human antibodies with any required specificity. Considering the rapid improvement in the methods involved in making human monoclonal antibodies, it is expected that their impact will gradually be of major importance in the clinical setting.

This volume presents technical protocols of cellular and molecular methods for the production, purification, and application of human monoclonal antibodies. In addition, this volume presents also a few review articles related to the topic of human monoclonal and polyclonal antibodies.

Jerusalem, Israel

Michael Steinitz

Contents

<i>Preface</i>	v
<i>Contributors</i>	ix
1 Human Monoclonal Antibodies: The Residual Challenge of Antibody Immunogenicity.	1
<i>Herman Waldmann</i>	
2 Technical and Ethical Limitations in Making Human Monoclonal Antibodies (An Overview).....	9
<i>Mark C. Glassy and Rishab Gupta</i>	
3 Therapeutic Human Monoclonal Antibodies in Inflammatory Diseases	37
<i>Sotirios Kotsovilis and Evangelos Andreakos</i>	
4 Therapeutic Human Monoclonal Antibodies Against Cancer.	61
<i>Jamie Jarboe, Anumeha Gupta, and Wasif Saif</i>	
5 Polyclonal and Monoclonal Antibodies in Clinic	79
<i>Bharath Wootla, Aleksandar Denic, and Moses Rodriguez</i>	
6 Production of Human Monoclonal Antibodies by the Epstein–Barr Virus Method.....	111
<i>Michael Steinitz</i>	
7 Humanization and Simultaneous Optimization of Monoclonal Antibody.	123
<i>T. Kuramochi, T. Igawa, H. Tsunoda, and K. Hattori</i>	
8 Chimeric Antibodies	139
<i>Kobei Kurosawa, Waka Lin, and Kunihiko Ohta</i>	
9 Recombinant Genetic Libraries and Human Monoclonal Antibodies	149
<i>Jarrett J. Adams, Bryce Nelson, and Sachdev S. Sidhu</i>	
10 Production of Stabilized scFv Antibody Fragments in the <i>E. coli</i> Bacterial Cytoplasm.	171
<i>Lilach Vaks and Itai Benhar</i>	
11 Construction and Production of an IgG-Like Tetravalent Bispecific Antibody, IgG–Single-Chain Fv Fusion	185
<i>Dan Lu and Zhenping Zhu</i>	
12 Construction of Human Antibody Gene Libraries and Selection of Antibodies by Phage Display	215
<i>André Frenzel, Jonas Kügler, Sonja Wilke, Thomas Schirrmann, and Michael Hust</i>	
13 Antigen-Specific Human Monoclonal Antibodies from Transgenic Mice.....	245
<i>Susana Magadán Mompó and África González-Fernández</i>	

14	Phage Display Technology for Human Monoclonal Antibodies.	277
	<i>Cecilia Deantonio, Diego Cotella, Paolo Macor, Claudio Santoro, and Daniele Sblattero</i>	
15	Antigen-Specific In Vitro Immunization: A Source for Human Monoclonal Antibodies.	297
	<i>Kosuke Tomimatsu and Sanetaka Shirahata</i>	
16	Methods for Radiolabelling of Monoclonal Antibodies.	309
	<i>Vladimir Tolmachev, Anna Orlova, and Karl Andersson</i>	
17	Purification of Human Monoclonal Antibodies and Their Fragments.	331
	<i>Thomas Müller-Späth and Massimo Morbidelli</i>	
18	Idiotypic-Specific Intravenous Immunoglobulin (IVIg) for Therapy of Autoimmune Diseases.	353
	<i>Miri Blank, Tomer Basbi, and Yehuda Shoenfeld</i>	
	<i>Index</i>	363

Contributors

- JARRETT J. ADAMS • *Terrence Donnelly Centre for Cellular and Biomolecular Research, University of Toronto, Toronto, ON, Canada; Banting and Best Department of Medical Research, University of Toronto, Toronto, ON, Canada; Department of Molecular Genetics, University of Toronto, Toronto, ON, Canada*
- EVANGELOS ANDREAKOS • *Laboratory of Immunogenetics, Immunobiology Division, Center of Immunology and Transplantation, Biomedical Research Foundation of the Academy of Athens, Athens, Hellas, Greece*
- KARL ANDERSSON • *Unit of Biomedical Radiation Sciences and Rudbeck Laboratory, Ridgeview Instruments AB, Uppsala, Sweden*
- TOMER BASHI • *Zabludowicz Center for Autoimmune Diseases, Sheba Medical Center, Tel-Aviv University, Tel-Aviv, Israel*
- ITAI BENHAR • *The George S. Wise Faculty of Life Sciences, Department of Molecular Microbiology and Biotechnology, Tel-Aviv University, Ramat Aviv, Israel*
- MIRI BLANK • *Zabludowicz Center for Autoimmune Diseases, Sheba Medical Center, Tel-Aviv University, Tel-Aviv, Israel*
- DIEGO COTELLA • *Department of Health Sciences and Interdisciplinary Research Center for Autoimmune Diseases (IRCAD), University of Eastern Piedmont, Novara, Italy*
- CECILIA DEANTONIO • *Department of Health Sciences and Interdisciplinary Research Center for Autoimmune Diseases (IRCAD), University of Eastern Piedmont, Novara, Italy*
- ALEKSANDAR DENIC • *Departments of Neurology and Immunology, Mayo Clinic, Rochester, MN, USA*
- ANDRÉ FRENZEL • *Abteilung Biotechnologie Technische Universität Braunschweig, Institut für Biochemie, Biotechnologie und Bioinformatik, Braunschweig, Germany*
- ÁFRICA GONZÁLEZ-FERNÁNDEZ • *Directora del Centro de Investigación Biomédica (CINBIO), Vigo, Pontevedra, Spain; Catedrática de Inmunología Universidad de Vigo, Vigo, Pontevedra, Spain*
- MARK C. GLASSY • *Integrated Medical Sciences Association Foundation, San Diego, CA, USA*
- ANUMEHA GUPTA • *Tufts University School of Medicine, Boston, MA, USA*
- RISHAB GUPTA • *BioProbe International, Inc., and University of California, Los Angeles, CA, USA*
- K. HATTORI • *Research Division, Chugai Pharmaceutical Co., Ltd., Gotemba, Shizuoka, Japan*
- MICHAEL HUST • *Abteilung Biotechnologie, Technische Universität Braunschweig, Institut für Biochemie, Biotechnologie und Bioinformatik, Braunschweig, Germany*
- T. IGAWA • *Research Division, Chugai Pharmaceutical Co., Ltd., Gotemba, Shizuoka, Japan*
- JAMIE JARBOE • *Tufts cancer center, Tufts university school of medicine, Boston, MA, USA*

- SOTIRIOS KOTSOVILIS • *Laboratory of Immunogenetics, Center of Immunology and Transplantation, Immunobiology Division, Biomedical Research Foundation of the Academy of Athens, Athens, Hellas, Greece*
- T. KURAMOCHI • *Research Division, Chugai Pharmaceutical Co., Ltd., Gotemba, Shizuoka, Japan*
- KOHEI KUROSAWA • *Department of Life Sciences, Graduate School of Arts and Sciences, The University of Tokyo, Tokyo, Japan*
- JONAS KÜGLER • *mAb-Factory GmbH, mAb-factory GmbH, Braunschweig, Germany*
- DAN LU • *Kadmon Corporation, New York, NY, USA*
- WAKA LIN • *Department of Life Sciences, Graduate School of Arts and Sciences, The University of Tokyo, Tokyo, Japan*
- PAOLO MACOR • *Department of Life Sciences, University of Trieste, Trieste, Italy*
- SUSANA MAGADÁN MOMPÓ • *Immunology, Biomedical Research Center (CINBIO); Institute of Biomedical Research (IBIV), Universidad de Vigo, Vigo, Spain*
- MASSIMO MORBIDELLI • *ETH Zurich, Institute for Chemical and Bioengineering, Zurich, Switzerland*
- THOMAS MÜLLER-SPÄTH • *ETH Zurich, Institute for Chemical and Bioengineering, Zurich, Switzerland*
- BRYCE NELSON • *Terrence Donnelly Centre for Cellular and Biomolecular Research, University of Toronto, Toronto, ON, Canada; Banting and Best Department of Medical Research, University of Toronto, Toronto, ON, Canada; Department of Molecular Genetics, University of Toronto, Toronto, ON, Canada*
- KUNIHIRO OHTA • *Department of Life Sciences, Graduate School of Arts and Sciences, The University of Tokyo, Tokyo, Japan*
- ANNA ORLOVA • *Preclinical PET Platform, Department of Medicinal Chemistry, Uppsala University, Uppsala, Sweden*
- MOSES RODRIGUEZ • *Departments of Neurology and Immunology, Mayo Clinic, Rochester, Rochester, MN, USA*
- WASIF SAIF • *Tufts University School of Medicine, Boston, MA, USA*
- CLAUDIO SANTORO • *Department of Health Sciences and Interdisciplinary Research Center for Autoimmune Diseases (IRCAD), University of Eastern Piedmont, Novara, Italy*
- DANIELE SBLATTERO • *Department of Health Sciences and Interdisciplinary Research Center for Autoimmune Diseases (IRCAD), University of Eastern Piedmont, Novara, Italy*
- SACHDEV S. SIDHU • *Terrence Donnelly Centre for Cellular and Biomolecular Research, University of Toronto, Toronto, ON, Canada; Banting and Best Department of Medical Research, University of Toronto, Toronto, ON, Canada; Department of Molecular Genetics, University of Toronto, Toronto, ON, Canada*
- MICHAEL STEINITZ • *The Department of Pathology, The Lautenberg Center for General and Tumor Immunology; IMRIC, The Hebrew University-Hadassah Medical School, Jerusalem, Israel*
- SANETAKA SHIRAHATA • *Faculty of Agriculture, Department of Bioscience and Biotechnology, Kyushu University, Higashi-ku, Fukuoka, Japan*
- THOMAS SCHIRRMANN • *Technische Universität Braunschweig, Institut für Biochemie, Biotechnologie und Bioinformatik, Abteilung Biotechnologie, Braunschweig, Germany*
- YEHUDA SHOENFELD • *Zabludowicz Center for Autoimmune Diseases, Sheba Medical Center, Tel-Aviv University, Tel-Aviv, Israel*

- VLADIMIR TOLMACHEV • *Unit of Biomedical Radiation Sciences, Rudbeck Laboratory, Uppsala University, Uppsala, Sweden*
- KOSUKE TOMIMATSU • *Faculty of Agriculture, Department of Bioscience and Biotechnology, Kyushu University, Fukuoka, Japan; Japan Society for the Promotion of Science, Tokyo, Japan*
- H. TSUNODA • *Research Division, Chugai Pharmaceutical Co., Ltd., Gotemba, Shizuoka, Japan*
- LILACH VAKS • *The George S. Wise Faculty of Life Sciences, Department of Molecular Microbiology and Biotechnology, Tel-Aviv University, Ramat Aviv, Israel*
- HERMAN WALDMANN • *Sir William Dunn School of Pathology, Oxford, UK*
- SONJA WILKE • *mAb-Factory GmbH, mAb-factory GmbH, Braunschweig, Germany*
- BHARATH WOOLLA • *Departments of Neurology and Immunology, Mayo Clinic, Rochester, MN, USA*
- ZHENGPING ZHU • *Kadmon Corporation, New York, NY, USA*

Chapter 1

Human Monoclonal Antibodies: The Residual Challenge of Antibody Immunogenicity

Herman Waldmann

Abstract

One of the major reasons for seeking human monoclonal antibodies has been to eliminate immunogenicity seen with rodent antibodies. Thus far, there has yet been no approach which absolutely abolishes that risk for cell-binding antibodies. In this short article, I draw attention to classical work which shows that monomeric immunoglobulins are intrinsically tolerogenic if they can be prevented from creating aggregates or immune complexes. Based on these classical studies two approaches for active tolerization to therapeutic antibodies are described.

Key words Therapeutic antibodies, Immunogenicity, Adjuvanticity, High-dose tolerance, Humanized and human antibodies

1 Introduction

Although monoclonal antibodies were first described in 1975 [1], their potential as therapeutic agents was not properly appreciated until technology evolved to replace the original rodent forms with human equivalents [2–8]. The reasons for this are complex, but relate to a combination of perceptions related to patentability, immunogenicity, effector function, and wish to avoid undesirable side effects. Undoubtedly the terms *human* or *humanized* carried some emotive advantage over *rodent*, *murine*, or *rat* in giving comfort that agents close to the human form were somehow preferable, even before all the evidence was in [9]. That emotive argument has even been extended to comparisons between *fully human* as opposed to more *humanized* antibodies, as if there were some important and significant functional difference. Undoubtedly though, the commercially driven demand for human antibodies has, to its credit, catalyzed technologies related to antibody engineering and manufacture which have aided commercialization in a very productive way. The basic human constructs and expression

vectors generated for the purpose have also served as templates to enable generation of antibody variants designed to deliver improved therapeutic performance [10].

In this short chapter, I discuss the problem of antibody immunogenicity, and whether evolution to human forms offers solutions to the perceived problems.

2 Immunogenicity

It has long been known that “foreign” polyclonal antibodies are potentially immunogenic in humans and in experimental animals. Seminal studies from Chiller and Weigle indicated that even though human immunoglobulins were foreign to mice, when given as monomers, they were tolerogenic rather than immunogenic [10]. However, given as aggregates, they were obligate immunogens. At high doses the monomers could tolerize both T-helper cells and B-cells, but at low doses would only tolerize the T-helper cells [10]. As therapeutic antibodies tended to target antigens within the body, it was likely that, when bound to cell-surface antigens, they would be generating “immunogenic” aggregates within the treated hosts. Whereas polyclonal antibodies might bind to multiple epitopes within the antigen, monoclonal antibodies would be restricted to just one or very few such targets.

In 1986, we examined a series of rat antibodies that were directed towards leucocyte antigens and found that virtually all proved immunogenic, except antibodies to the CD4 molecule [11].

In contrast, monomeric rat monoclonal immunoglobulins that did not bind to leucocytes, proved non-immunogenic, but were actually tolerogenic, in markedly reducing the antibody response to cell-binding antibodies given at a later time. It also emerged that the anti-CD4 antibodies were indeed directing the immune system to regard them as tolerogens, as well as other proteins that might be given under the umbrella of the anti-CD4 therapy. This observation formed the basis for many subsequent studies on therapeutic reprogramming of the immune system through recruitment of host tolerance mechanisms [12]. These findings suggested that antibodies binding to leucocytes simulated the Chiller–Weigle aggregates in generating sufficient adjuvanticity to evoke immune responses, but also left some questions about what target cell type or antigen was needed for that purpose. To this day, there has been very little attention to this question. For example, what if the target antigen was a monomer in solution, or a trimer (such as TNF)? Would therapeutic antibodies to these be more immunogenic. As mentioned earlier, tolerogenicity can be quite dose dependent, and therapeutic doses of antibodies may not achieve the level required to tolerize both T- and B-cells.

Monoclonal Ab's directed at human cell-surface targets are potentially immunogenic even if humanized, as their CDRs are effectively "foreign".

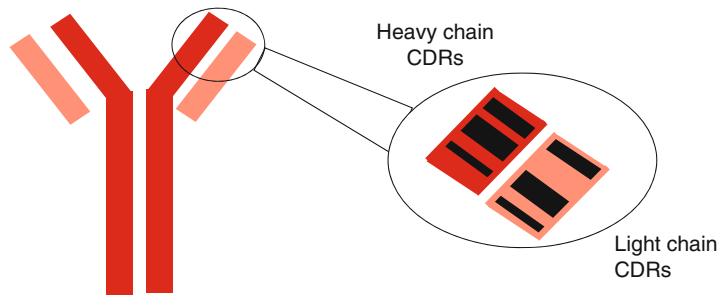

The complete IgG molecule.

Fig. 1 Monoclonal Abs directed at human cell-surface targets are potentially immunogenic even if humanized, as their CDRs are effectively "foreign". The bulk of the humanized Ab (so-called frameworks-in *red*) is tolerated as if "self". The complementarity determining regions (CDRs) which bind antigen are, however, still foreign

As humans are largely tolerant of the constant regions of their own antibodies (self-tolerance), it was assumed that human antibodies, or engineering of antibodies to a human form, would bypass the immunogenicity problem. The concept was supported by evidence that the closer a monoclonal immunoglobulin was engineered towards host-type, then the less immunogenic it proved [3]. In a study comparing a humanized anti-CD52 antibody with a previous administration of the rodent form, the humanized version appeared far less immunogenic after a single course [13].

However, the humanization approach depended on retention of the original murine CDRs within the new human framework (Fig. 1), and so eventual immunogenicity was still a potential issue. The notion of fully human antibodies implied that humans would be tolerant to the CDRs and framework—overlapping regions of antibodies derived from a human repertoire. This cannot be the case [9]. We know from past work that anti-idiotypic responses can be generated to one's own antibodies [14]; and we also know that in the evolution of an antibody response, VJ and VDJ recombinations as well as somatic hypermutation can change the CDRs away from their germ line configuration. Consequently, there is still no evidence-based argument that would make the case for fully human antibodies being less immunogenic than humanized antibodies. In a published study of the humanized CD52 antibody (CAMPATH-1H or alemtuzumab), the majority of patients treated with a second course of antibody made strong anti-idiotypic responses to the humanized therapeutic [15]. This teaches us that the CDRs can remain a focus of the host immune response to humanized (and probably also human) monoclonal antibodies.

3 Overcoming the Immunogenicity Problem

The current portfolio of antibody therapeutics comprises members for whom immunogenicity has yet to be identified as a problem and others for whom immunogenicity is well documented. In some scenarios, the use of an additional immunosuppressive drug may not only benefit the target disease but also mask the extent of antibody immunogenicity [16]. Where immunogenicity has arisen, options may be available to switch to a different agent serving the same purpose, or even to a different antibody target, as in anti-TNF therapy. Where immunogenicity has not occurred, we may not always be able to establish why. In other words, is lack of immunogenicity a feature of the target antigen, the dose, or some unique feature of the therapeutic agent?

Nevertheless, when all the information from clinical studies is made available, there will surely be particular antibodies where immunogenicity will have been shown to limit clinical utility. What can be done to more effectively control immunogenicity? There are a number of directions that might be considered.

One is to recognize that in order for T-cells to recognize the “foreign” determinants it is essential that the antibody is processed into peptides that can bind to MHC Class II [17, 18]. By scanning the primary sequence of antibody heavy and light chains for potential T-cell epitopes it has been claimed that one can purge the therapeutic of T-cell epitopes. The success of this depends upon such drugs being manufactured and assessed in clinical trials, as there really is no *in vitro* system that can replace the *in vivo* assessment. Until that is achieved in a head to head comparison with a conventional antibody we cannot be certain that this will eliminate the problem.

Another is to find a route to tolerize the patient to the therapeutic antibody, so that any immune response would be rendered impossible [19]. This may sound counterintuitive, but we know from Chiller and Weigle that this ought to be possible. In principle, a tolerogenic form of the therapeutic antibody might be generated if one could produce a limited number of mutations in the key CDRs concerned with antigen binding. A few mutations that could drastically reduce binding could provide a tolerogenic version which would be given ahead of the non-mutated therapeutic form of the antibody. The feasibility of this approach has been demonstrated in mice transgenic for the human CD52 antigen [20]. A human IgG1 antibody to CD52 was used to ablate mouse T-lymphocytes. This ablation was associated with immunogenicity of the foreign antibody. In contrast, mice that had previously received single or double mutant forms of the antibody which were markedly reduced in their binding (Fig. 2), could not be immunized to either the tolerogen nor to challenge with the therapeutic form (Fig. 3). This provides a clear demonstration that high-dose tolerance to the mutant prevented a response to the therapeutic version.

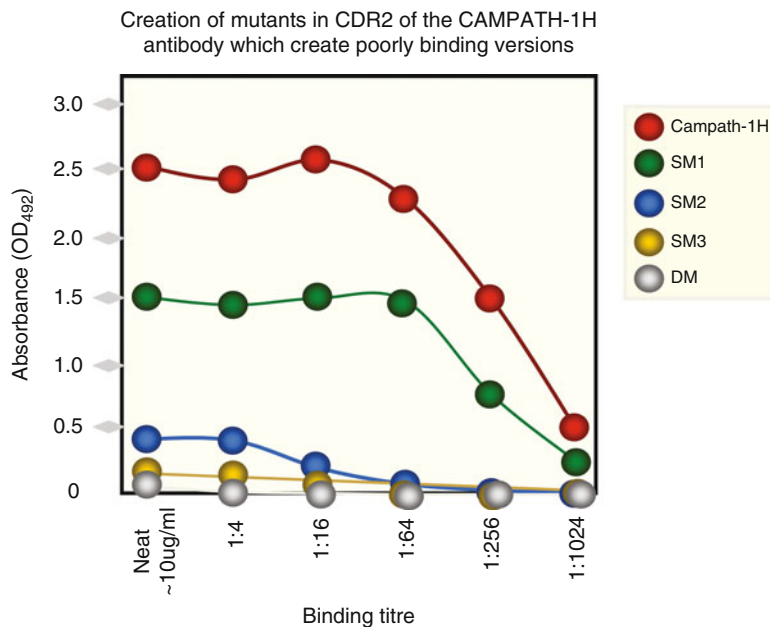

Fig. 2 Creation of mutants in CDR2 of the CAMPATH-1H antibody which create poorly binding versions. Mutants can be created in the CDR regions which render the antibody far less able to bind to cells. In this case mutants were created in CDR2 of the heavy chain of the CAMPATH-1H anti-CD52 antibody. *SM* single mutations, *DM* double mutants. Binding to antigen is substantially reduced by three (*blue, yellow, and gray symbols*) of the four mutant antibodies compared to the original therapeutic (*red*). Adapted from Gilliland et al. (1999)

This two stage tolerizing protocol was applied in a small-scale clinical study in patients given the IgG1 CD52 antibody, alemtuzumab, as a treatment for multiple sclerosis. A mutant “tolerogen” given before treatment substantially diminished the antibody response to a primary course of the therapeutic, as well as a second course given 1 year later [15].

Although impressive the disadvantage of this tolerizing approach is the need to manufacture and utilize two antibody forms. Thus far, no pharmaceutical company has made use of this strategy.

Is it possible that one could produce a version of the therapeutic antibody which can serve both as a tolerogen, yet still be able to exert its functional effect on cells? Such a one-step strategy has been achieved by engineering a covalently attached antigen mimotope into the antibody binding site [21] (Fig. 4). As the blocker mimotope renders the major proportion of antibody molecules “nonbinding” at time of infusion, it allows tolerogenesis before the bulk cell-binding consequences become effective. This “stealth” antibody, although tolerogenic in the mouse model, has not yet been subject to a clinical test. By reducing the pace of the lytic effect of the drug, it has also been possible to diminish some of the “cytokine” release-dependent side effects of CD52 antibody therapy.

Poorly-binding mutants tolerise CD52-transgenic mice to subsequent CAMPATH-1H treatment.

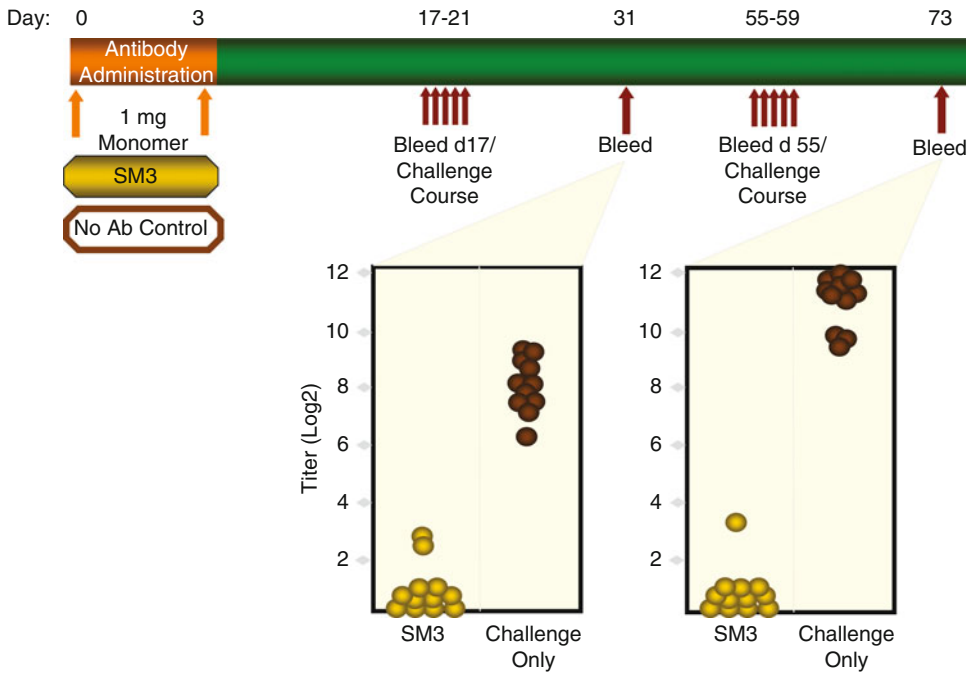

Fig. 3 Poorly binding mutants tolerize CD52-transgenic mice to subsequent CAMPATH-1H treatment. CD52 transgenic mice were pretreated with two injections of 1 mg of a poorly binding mutant in CDR2 of the heavy chain of CAMPATH-1H. From 17 days later mice were given multiple challenges with the wild-type therapeutic. “Tolerogen” pretreated mice made negligible antibody responses to the therapeutic. Adapted from Gilliland et al. (1999)

There are obvious variations of this approach that could include concomitant administration of reversible “chemical” blockers of the antigen-binding site given together with the therapeutic, creating an initial “blocked” tolerogen whose cell binding eventually returns once the blocker is cleared.

It should be noted that the experimental models shown above both used human antibodies injected into mice. Tolerization was achieved despite the extensive degree of “foreignness”. However, even though humans might prove tolerizable to rodent antibodies, it seems sensible to apply the tolerization approaches to antibodies whose constant regions are human, so making the task of tolerization easier. Moreover, as human constant regions are likely to be subject to various engineering strategies to optimize function, then one should regard the human rather than rodent frameworks as the template for such improvements.

Creation of “stealth antibodies that can self-tolerise yet retain the ability to bind to cells”

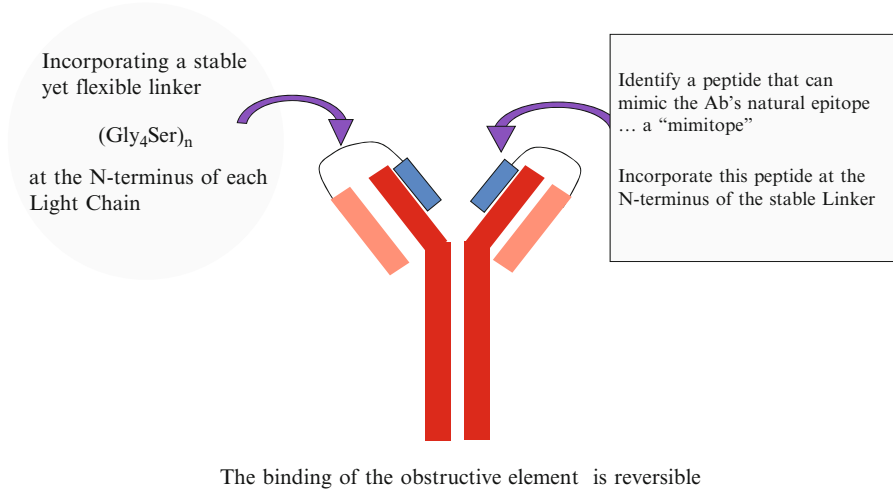

Fig. 4 Creation of “stealth antibodies that can self-tolerize yet retain the ability to bind to cells” (From issued patent US 7,465,790B2-Therapeutic Antibodies). A peptide mimotope of the CD52 epitope is covalently bound into the CAMPATH-1H binding site. This severely impairs binding, allows tolerogenesis, but still allows cell lysis

4 Prospects and Conclusions

Thus far human antibodies seem to have satisfied the requirements of the biopharmaceutical industry even with antibodies where immunogenicity has been established. The need to do more has become an issue of investment against likely demand, and at this stage of the therapeutic antibody experience, the need for a tolerizing change, has not yet become a priority. I would venture that for some antibodies immunogenicity will never be a problem, but for others it may substantially enhance the longevity of the antibody as a drug. Given this, we should continue to evolve methodologies which can guarantee elimination of immunogenicity so as to ensure that we can use monoclonal antibodies as effectively as possible.

References

1. Kohler G, Milstein C (1975) Continuous cultures of fused cells secreting antibody of predefined specificity. *Nature* 256:495–497
2. Steinitz M et al (1977) EB virus-induced B lymphocyte cell lines producing specific antibody. *Nature* 269:420–422
3. Bruggemann M et al (1989) The immunogenicity of chimeric antibodies. *J Exp Med* 170: 2153–2157
4. Jones PT et al (1986) Replacing the complementarity-determining regions in a human antibody with those from a mouse. *Nature* 321:522–525
5. Riechmann L et al (1988) Reshaping human antibodies for therapy. *Nature* 332: 323–327
6. Bruggemann M et al (1989) A repertoire of monoclonal antibodies with human heavy

- chains from transgenic mice. *Proc Natl Acad Sci USA* 86:6709–6713
7. Lonberg N (2005) Human antibodies from transgenic animals. *Nat Biotechnol* 23:1117–1125
 8. Winter G et al (1994) Making antibodies by phage display technology. *Annu Rev Immunol* 12:433–455
 9. Clark M (2000) Antibody humanization: a case of the “Emperor’s new clothes”? *Immunol Today* 21:397–402
 10. Chiller JM et al (1970) Cellular sites of immunologic unresponsiveness. *Proc Natl Acad Sci USA* 65:551–556
 11. Benjamin RJ et al (1986) Tolerance to rat monoclonal antibodies. Implications for serotherapy. *J Exp Med* 163:1539–1552
 12. Waldmann H et al (2008) Reprogramming the immune system: co-receptor blockade as a paradigm for harnessing tolerance mechanisms. *Immunol Rev* 223:361–370
 13. Rebello PR et al (1999) Anti-globulin responses to rat and humanized CAMPATH-1 monoclonal antibody used to treat transplant rejection. *Transplantation* 68:1417–1420
 14. Eichmann K (1973) Idiotypic expression and the inheritance of mouse antibody clones. *J Exp Med* 137:603–621
 15. Somerfield J et al (2010) A novel strategy to reduce the immunogenicity of biological therapies. *J Immunol* 185:763–768
 16. Feldmann M, Maini RN (2001) Anti-TNF alpha therapy of rheumatoid arthritis: what have we learned? *Annu Rev Immunol* 19:163–196
 17. De Groot AS, Scott DW (2007) Immunogenicity of protein therapeutics. *Trends Immunol* 28:482–490
 18. Harding FA et al (2010) The immunogenicity of humanized and fully human antibodies: residual immunogenicity resides in the CDR regions. *MAbs* 2:256–265
 19. Isaacs JD, Waldmann H (1994) Helplessness as a strategy for avoiding antiglobulin responses to therapeutic monoclonal antibodies. *Ther Immunol* 1:303–312
 20. Gilliland LK et al (1999) Elimination of the immunogenicity of therapeutic antibodies. *J Immunol* 162:3663–3671
 21. Waldmann HF, Gilliland MK, Graca L (2008) Therapeutic antibodies. US 7,465,790 B2

Chapter 2

Technical and Ethical Limitations in Making Human Monoclonal Antibodies (An Overview)

Mark C. Glassy and Rishab Gupta

Abstract

In the broadest sense there are no longer any technical limitations to making human mAbs. Biological issues involving the type and nature of either a synthetic or a natural antibody, advantages of various B cell immunological compartments, and various assays needed to qualitate and quantitate mAbs have essentially been solved. If the target antigen is known then procedures to optimize antibody development can be readily planned out and implemented. When the antigen or target is unknown and specificity is the driving force in generating a human mAb then considerations about the nature and location of the B cell making the sought after antibody become important. And, therefore, the person the B cell is obtained from can be an ethical challenge and a limitation. For the sources of B cells special considerations must be taken to insure the anonymity and privacy of the patient. In many cases informed consent is adequate for antibody development as well as using discarded tissues. After the antibody has been generated then manufacturing technical issues become important that greatly depend upon the amounts of mAb required. For kilogram quantities then special considerations for manufacturing that include FDA guidelines will be necessary.

Key words Natural antibodies, Recombinant antibodies, B cells, Clinical studies, Manufacturing, Informed consent

1 Introduction

Any antibody to any dimensional structure can be made. Though the antibody may determine the structure; the structure may also determine the antibody. If a particular target has been chosen then virtually any antibody (or fragment) can be generated that not only recognizes the chosen target but effector function features can also be engineered into the antibody so that other elements of the immune response can be utilized for a stronger and longer-lasting effect.

With so many choices available through antibody engineering one has the obvious advantage of being able to select the type and nature of antibody to be used. If the primary use of the antibody is as a diagnostic then different procedures and protocols will be used to generate the antibody. However, if the end use is as a therapeutic

then more stringent (and inherently more expensive) procedures and protocols must be used.

In a natural immune environment B cells undergo a maturation process in germinal centers where somatic cell hypermutation and class switch recombination of the immunoglobulin genes, all under the control of activation-induced deaminase (AID), occurs that results in a “best fit” antibody better able to recognize its target. Most importantly, the complementary determining regions (CDR) of the antibody are critical to immune recognition and CDRs can be added to virtually any binding region for which molecular cascades may already exist. Those B cells with the highest affinity best-fit CDR variable domains preferentially capture interactions with T cells resulting in a stronger and longer lasting immune response.

Decision making in generating diagnostic and/or therapeutic human monoclonal antibodies (hmAbs) can be simplified based on its final application. Is the hmAb an end where the type, nature, and subclass are important, or a means to an end where the focus is on the antigen target? Will the antibody be used naked or conjugated or modified to enhance biological function(s) such as seen with antibody drug conjugates [1]. With so many choices available then effective strategies must be determined to minimize wasted time and resources in developing an antibody of interest. It is of utmost importance that with all the potential choices available there should be rational decision making throughout all phases of the entire antibody development process.

All of these various options and therefore decisions to make in developing the hmAb of need are focused on the antibody itself once it has been biologically formed. However, questions pertaining to how the antibody became biologically formed need to be discussed. More importantly, what influences were used to steer the B lymphocyte to undergo its final CDR selection? The answers to this are complicated and vary in the area of antibody engineering to develop diagnostically and therapeutically useful antibodies [2–4].

The flow of binding information from antibody genes to the final high-affinity molecule is highly regulated and dependent upon many aspects of the overall immune response. Several variables must be properly integrated for the development of a successful antibody. Important are the structure and properties of the target as well as the isotype, affinity, and pharmacodynamics-pharmacokinetic properties of the antibody itself. And during the early phases of antibody development the cross-reactive properties of binding also play a role in the final creation of the antibody.

2 Human Monoclonal Antibodies

Human antibodies are elicited in response to invading substances (antigens) by B cells. The antigen(s) could be a part of an invading microbe, nonself cells, or mutated/altered self cells such as cancer cells.

For a complete immune response various immune cells, in addition to B cells, function together to activate the overall immune system. As a result of the immune response B cells produce antibodies that are specific to an antigen or part (epitope) of an antigen.

Antibodies by themselves can destroy or inactivate cells and neutralize substances via a number of mechanisms mediated by nonbinding regions of the antibody. These mechanisms may require complement and other immune cells, such as NK cells. Because of therapeutic and diagnostic applications of antibodies in human health (control of infectious diseases, autoimmunity, cancer, and other human ailments), they have played a central role in investigative efforts to exploit them to their fullest extent. The first mAbs, of murine origin, were developed more than 35 years ago as an unlimited source of a single specificity. However, once in the clinic the xenogeneic nature of the murine mAb resulted in a human anti-murine antibody (HAMA) response in patients that negated the effects of the therapy. Due to these unwanted HAMA responses various modifications of mAbs to reduce or eliminate the undesired side effects in human were developed which led to the development of chimerized, humanized, and totally human versions. In addition, innovative in vivo diagnostic and therapeutic applications led to modifications of antibody size [single chain (sFv)] and enhancement of their biological activities [5].

2.1 Technical Limitations

Currently, with the advancements of molecular biology there are very few, if any, technical limitations to physically making any antibody molecule. However, there are limitations in the source of B cells and in the manufacturing of clinical grade antibody. Sources of patient's B cells are peripheral blood (PBL), spleen, lymph nodes, Peyer's patches, cord blood, tumor-infiltrating B cells, bone marrow, liver, skin, and tonsils.

There are many immortalization procedures available ranging from Epstein-Barr virus (EBV) immortalization, classical hybridoma procedures, phage display, or by isolating single B-cells by sorting followed by molecular cloning of the antibody genes. Technical limitations on EBV immortalized cells are primarily due to the genetic instability of clones and that only those B cells that are C3b positive, the binding receptor for EBV, are immortalized. For generating classical hybridomas technical limitations center on the choice of fusion partner. Mouse myeloma cells, such as the "653" myeloma are useful, but mouse-human hybridomas are inherently genetically unstable. There are several human fusion partners available that are of B-lymphoblastoid origin that are effective. The limitation with fusion partners is their low efficiency and labor-intensive work necessary to grow and expand many hybridoma colonies.

Other technical limitations center on the source of antigen/target/epitope where either the B cell has been directly immunized to recognize the antigen or the patient's own immune

response created the antibody, and therefore antigen, of interest. An important consideration is whether the antigen is stable or a conformational epitope. Also, if the target antigen is cell bound, cytoplasmic, or shed/secreted will impact on the technical steps in quantitation and qualitation.

Hybridoma development for antigen discovery in oncology typically includes a differential screen to identify antigens that are highly expressed on tumor cells and sparingly expressed and ideally absent on non-tumor cells. Screening for cell surface antigens can be carried out using FACS analysis, antibody-cell capture, or fluorometric microvolume assay technology (FMAT). FMAT devices automate microtiter plate reading and handling, thereby facilitating high throughput screening of cell-binding or killing activities in hybridoma wells [6]. Dominant epitopes can skew the repertoire of hybridomas and limit the diversity of antigens detected. This problem is potentially exacerbated by the weak immunogenicity of some tumor antigens. The impact of dominant epitopes can be minimized by using a subtractive immunization approach (Hooper et al. [7] and Zijlstra et al. [8]) or by incorporating a highly selective screen.

Hybridoma technology quickly emerged as a rapid and powerful method to identify novel cell surface markers [9]. Immunophenotyping with mAbs raised to cell surface markers defined the differentiation status of hematopoietic cells and became the basis for the “clustering of differentiation” or CD classification [10]. Immunophenotyping of hematopoietic cells and hematologic malignancies is commonly performed by FACS analysis, a technique that can detect and quantify antigen expression on the cell surface. FACS analysis revealed that some CD antigens commonly expressed on hematopoietic cells are also expressed on hematologic tumors. CD20, for instance, is a B cell lineage marker expressed on >90 % B-cell non-Hodgkin’s lymphomas and is the target for the human mAbs Rituxan, Zevalin, and Bexxar. Limitations notwithstanding, hybridoma technology has historically been the most widely used method for tumor antigen discovery. Indeed, many antigens currently being targeted by antibodies in oncology clinical trials were first identified using hybridoma-derived mAbs, including sialyl LewisY [11] and prostate-specific membrane antigen (PSMA; ref. 12).

The number of tumor-associated targets that are identified and advanced to the validation stage is highly dependent upon the scale and methodology of the identification process including the selection criteria. Commonly, one might obtain tens to a few hundred targets that satisfy minimal criteria for tumor association. Pragmatically, the stringency of selection criteria can be increased, if need be, to identify a smaller number of lead targets that match available capacity to validate them [13].

The search for surface antigens on tumor cells amenable to antibody targeting commonly begins with a hunt for differences between tumor and non-tumor cells at the DNA, mRNA, protein or antibody reactivity levels. Thus far, no single approach or even combination of methods has emerged as the preferred way to identify surface antigens suitable for targeting in oncology. Genomics, specifically the availability of the human genome sequence, has empowered more direct means of target identification, e.g., by expanding protein databases and enabling the mapping of novel cancer-associated genes [14, 15]. Transcriptomic methods have proved particularly powerful in defining gene expression signatures for cancer diagnosis or prognosis, but less so to date for the identification of potential antibody targets. The most promising application of transcriptomics, from an antibody target perspective, is the discovery of tumor-specific splice variants. Low prevalence of antigens, including splice variants, is a potentially limiting factor in their exploitation for commercial antibody drug development.

Proteomic methods are appealing in that they allow a direct search for cell surface features that distinguish tumor cells from their normal counterparts. Rapid progress in expanding the throughput and capabilities of mass spectrometry bode well for proteomic identification of new tumor-associated antigens. Ideally, target validation includes profiling the expression of antigens across numerous normal tissues and tumor types. For the most promising candidates it is desirable to expand the survey of positive tumors to include large numbers of specimens at each stage of disease to provide robust estimates of the extent and prevalence of antigen expression. Such extensive expression profiling has only recently become feasible with the advent of so called tissue microarrays (TMA) that allow in situ profiling of protein, mRNA or DNA on hundreds of samples in parallel. Currently, there is a dearth of convincingly validated surface antigens that is compounded by the scarcity of so-called “naked” antibodies with robust anti-tumor activity. Fortunately, the potency of anti-cancer antibodies can be improved in numerous ways [16–20]. Thus, for validated targets there is often a compelling rationale to enhance the activity of corresponding antibodies for human therapy and a growing box of tools with which to do so. Our hope and expectation is that the marriage of target identification with antibody enhancement technologies will ultimately translate into new and improved therapies for cancer, autoimmunity, infectious diseases, transplantation and search for biomarkers.

2.1.1 *Natural Antibodies*

The innate or natural immunity is the basis and key for all immune processes. Specific receptors on macrophages, dendritic cells, NK cells and natural antibody producing B cells act as a first line defense and remove all “foreign” and potentially harmful substances,

including bacteria, viruses, cellular waste, modified molecules and, most importantly, cancer cells. Recognition and removal of transformed cells is a lifelong task of immune surveillance processes and antibodies are hallmark components of this anti-cancer activity. The majority of the tumor-specific natural antibodies are of the IgM class and have been found to be germ-line coded [21, 22]. Furthermore, these natural IgM antibodies primarily bind to new carbohydrates on post-translationally modified cell surface receptors on malignant cells. So far no affinity matured IgM detecting tumor-specific peptides have been found. However, it should be noted that only the presentation of peptide motifs can create an immunological memory [23]. In general malignant cells are detected at very early precursor stages and manifest tumors can be considered as exceptional events. In addition, malignant cells are neither infectious nor hide intracellularly like viruses and some bacteria. Therefore, it makes sense that anti-tumor immunity seems to be solely a part of the natural immunity and memory is not needed and therefore not induced. This indicates that tumor immunity seems to be restricted to innate immune mechanisms and the instruments used by nature, such as natural antibodies, are obviously excellent therapeutics [24].

2.1.2 B-Cell Immune Response Is Compartmentalized

It has long been recognized that only a small fraction of B and T lymphocytes are specific for a single protein antigen, such as tetanus toxin, yet these cells must come together if an antibody response is to occur. Bringing antigen-presenting cells and rare antigen-specific B and T lymphocytes into physical contact is a principal function of secondary lymphoid organs. Details have emerged that guide cell movements inside lymphoid organs, and a central role for the chemokine family of molecules has been uncovered that bring about this movement [25].

2.1.3 Immune Ecology and Niche Habitats Vary Considerably

With the development of the cancer stem-cell concept, which was first proposed half a century ago but was only empirically shown by the pioneering work of Dick and others, another dimension of the niche as a “druggable” target is beginning to take shape [26]. If cancer is organized in a manner similar to normal tissue, with a minor subpopulation of stem cells, an attendant blood supply and a unique microenvironment, there might be a similar dependence of the stem cells on a cancer niche. The possibility of a niche has been shown by multiple studies indicating distinctive features of noncancerous cells within a tumor, and by the recent report of a population of bone-marrow-derived cells paving the way for subsequent establishment of a tumor focus. If the components of this niche could be demonstrated and targeted, it would be of considerable interest to modify the relative support of the stem-like cells of cancer. The idea that the niche might be a druggable target would be extremely appealing as an adjunctive and entirely independent

means of targeting malignant cells. Perhaps the niche will be more than a biologist's puzzle, and will become a guide for novel therapies to enhance the regenerative capacity of normal stem cells and limit the malignant potential of cancerous ones [27].

2.1.4 *Migrating B-Cells*

B-cell development occurs in the bone marrow and is strictly dependent on close interaction of B-cell progenitors with stromal cells that produce cytokines capable of supporting B-cell survival and proliferation [28]. Thus, we investigated whether mesenchymal stem cells, which derive from the marrow stroma, affect mature B-cell functions. Furthermore, it has been determined that human mesenchymal stem cells inhibit in vitro human B-cell proliferation, differentiation to antibody secreting cells, and chemotaxis [29].

2.1.5 *Source of Human Lymphocytes*

Even under physiological circumstances it is not only the classical lymphoid organs such as the thymus, lymph nodes and spleen which contain lymphocytes, but also a variety of non-lymphoid organs, for instance the lung, gut, and skin. Lymphocytes also occur in many body fluids and infiltrate tumor masses [30], indicating a unique feature of these cells: they are mobile and able to function both solitarily and in close collaboration with other lymphoid and non-lymphoid cells [31]. As a result, a number of sources of human lymphocytes have been employed to develop human monoclonal antibodies. These include but are not limited to peripheral blood lymphocytes (PBLs), spleen, tumor infiltrating B-lymphocyte (TIL-B), lymph nodes, tonsils, cord blood, Peyer's patches, bone marrow, liver, skin, etc. However, peripheral blood lymphocytes (PBLs) have been the most widely used source due to ease of procurement.

2.1.6 *Natural Immune Response as a Drug Discovery Platform*

The natural human IgM, SK-1, has been used in a phase I trial with colorectal patients [32, 33]. SK-1 sufficiently accumulated in cancer tissues when used for immunoscintigraphy [32] and a dose of up to 30mgs was administered safely [33]. SK-1 was i.v. administered at 2, 4, or 10 mg doses three times to three groups of patients with recurrent colon cancer. In this Phase I study, for 6 of the 9 treated patients, the mean rate of serum CEA level increase declined significantly during the 8 weeks following treatment [33] suggesting the IgM did have an effect on the cancer cells.

Though rare natural IgG antibodies, primarily those derived from sentinel lymph nodes (see below), have been reported [34, 35]. These IgG antibodies recognize cell surface molecules and therefore may be indicative of an active immune surveillance. Cocktails of these IgG antibodies have shown a synergistic response in a xenograft model [34]. The natural IgG antibody, primumab, has been used in a phase II setting with 249 brain cancer patients [35] with an overall response rate of a ninefold benefit compared

to standard therapy. This suggests natural human antibodies may be useful in the clinic.

The antigen that is recognized by the natural human mAb, pritumumab, is vimentin [35, 36]. The epitope recognized by pritumumab resides on the coil II region of the vimentin molecule presenting a consolidated altered antigenicity because of its recognition by the paratope of pritumumab on the plasma membrane of the tumor cell but not on the normal cell. This tumor-associated epitope is expressed preferentially on the cell surface of synchronized cells at G2/M cell cycle phase. Daunomycin-conjugated pritumumab was developed to study the effective dose used for a more efficient tumor suppressive activity. Dosage efficiency was dramatically improved comparing with tumor cell killing between daunomycin-conjugated pritumumab and the naked pritumumab.

2.1.7 Conjugated Antibodies

Antibody conjugates are a diverse class of therapeutics primarily consisting of a cytotoxic agent linked covalently to an antibody or antibody fragment directed toward a specific cell surface target expressed by tumor cells. Early conjugates used mouse antibodies that were either too immunogenic, too toxic, or not sufficiently potent. Also, the early conjugates used linkers that were not sufficiently stable in circulation under physiological conditions. Investigators have explored four main avenues using antibodies to target cytotoxic agents to malignant cells: (1) antibody-protein toxin (or antibody fragment-protein toxin fusion) conjugates, (2) antibody-chelated radionuclide conjugates, (3) antibody-small-molecule drug conjugates, and (4) antibody-enzyme conjugates administered along with small-molecule prodrugs that require metabolism by the conjugated enzyme to release the activated species. Only antibody-radionuclide conjugates and antibody-drug conjugates have reached the regulatory approval stage, and nearly 20 antibody conjugates are currently in clinical trials. There are many appealing aspects of this technology and antibody conjugates may become a major contributor to improving treatment for cancer patients [1, 37].

2.1.8 Synthetic Antibodies

In a relatively short time, *in vitro* synthetic antibody libraries from natural repertoires have had a major impact on drug discovery and development, culminating with the recent approval of the first fully human antibody therapeutic, which was derived by phage display [38]. Numerous studies have reported synthetic repertoires that rival natural repertoires in terms of functionality, and more importantly, several of these examples involve applications for which synthetic antibodies are superior to their natural counterparts [39].

As insights are gained into the basic principles of library design and function, further progress is essentially guaranteed, because a central strength of the synthetic technology resides in the ability to improve repertoire designs in response to lessons from current

designs. It seems likely that universal libraries that can provide specificities against any antigen will be available in the near future, or alternatively, that focused libraries or mini-libraries may be designed for exceptional performance in specialized applications. An example is the creation of a mini-library from tumor-infiltrating B cells resulting in binders that recognize the ganglioside tumor-associated antigen, GD2 [30].

Regardless of the library type, it is clear that in vitro methods can alleviate immunogenicity issues by allowing for the direct engineering of human proteins. Furthermore, the ability to precisely control selection conditions allows high precision engineering of specificity and affinity, and synthetic libraries further permit the use of frameworks that are optimized for stability and manufacturing. In addition, the ability to target even the most highly conserved proteins should extend the reach of therapeutic antibodies to virtually any extracellular antigen. In the future, it has been suggested that gene therapy may make intracellular delivery of intrabodies possible, and the use of specialized synthetic libraries will be crucial to the success of such approach [40]. As in vitro technologies become further standardized, it is likely that automation will be used for high-throughput antibody generation in a proteomics environment [4, 41]. High-throughput approaches, combined with the ability to select directly on cells and tissues, may allow the discovery of new disease markers and potential therapeutic targets [42]. Clearly, recent advances in recombinant antibody technology have had a transformative effect on therapeutic biology. This may be just the beginning, as this field enters an era of complete control over antibody design, and perhaps, function [43].

2.1.9 Chimerized Antibodies

As mentioned above, the first mAbs used in the clinic were of mouse origin and as such were immunogenic in humans resulting in a HAMA response that made repetitive dosing with murine mAbs problematical. While mouse and human antibodies are structurally similar the differences between the two are sufficient to invoke an unwanted immune response. When murine mAbs were injected into humans this resulted in a number of host responses including the rapid removal of the mAb from the blood, systemic inflammatory effects, HAMA responses, and several other potentially severe side effects such as hypersensitivity, immunogenicity, and the increased risk of bleeding and thrombocytopenia [44].

In an effort to overcome these negative effects approaches using recombinant DNA have been developed since the mid 1980s. Initially, mouse DNA encoding the binding portion of a monoclonal antibody was merged with human heavy chain antibody-producing DNA in living cells, and the expression of this chimeric DNA through cell culture yielded a partially mouse, partially human mAb. In these constructs the variable region of the antibody is murine whereas the Fc region of the antibody is human. For this

product, the descriptive term “chimeric” monoclonal antibody has been used to reflect the combination of mouse and human DNA sources used in the recombinant process [45, 46].

2.1.10 Humanized Antibodies

These recombinant mAbs are antibodies from nonhuman species whose protein sequences have been modified to increase their similarity to antibody variants produced naturally in humans. The process of “humanization” is usually applied to mAbs developed for administration to humans (for example, antibodies developed as anticancer drugs). Humanization can be necessary when the process of developing a specific antibody involves its generation in a nonhuman immune system (such as that in xenomice). The protein sequences of antibodies produced in this way are partially distinct from homologous antibodies occurring naturally in humans, and therefore may be potentially immunogenic when administered to human patients. Not all mAbs designed for human administration need be humanized since many therapies are short-term interventions. It should be noted that humanized antibodies are distinct from chimeric antibodies. The latter also have their protein sequences made more similar to human antibodies, but carry a larger stretch of nonhuman protein [47]. The protein sequence of a humanized antibody is essentially identical to that of a human variant, despite the nonhuman origin of some of its complementarity determining region (CDR) segments responsible for the ability of the antibody to bind to its target antigen.

As listed below, humanization of antibodies can be achieved via a number of processes:

- *Humanizing via a chimeric intermediate*: Here, the humanization process includes the creation of a mouse–human chimera in an initial step (mouse Fab spliced to human Fc). Thereafter the chimera could be further humanized by the selective alteration of the sequence of amino acids in the Fab portion of the molecule. The process must be “selective” to retain the specificity for which the antibody was originally developed. That is, since the CDR portions of the Fab are essential to the ability of the antibody to bind to its intended target, the amino acids in these portions cannot be altered without the risk of undermining the purpose of the development. Aside from the CDR segments, the portions of the Fab sequence that differ from those in humans can be corrected by exchanging the appropriate individual amino acids. This is accomplished at the DNA level using mutagenesis [48].
- *Humanization by insertion of relevant CDRs into a human antibody “scaffold”*: It is possible to produce a humanized antibody without creating a chimeric intermediate. “Direct” creation of a humanized antibody can be accomplished by inserting the appropriate CDR coding segments (responsible

for the desired binding properties) into a human antibody “scaffold.” As discussed above, this is achieved through recombinant DNA methods using an appropriate vector [49] with subsequent expression in mammalian cells. That is, after an antibody is developed to have the desired properties in a mouse (or other nonhuman), the DNA coding for that antibody can be isolated, cloned into a vector, and sequenced. The DNA sequence corresponding to the antibody CDRs can then be determined. Once the precise sequence of the desired CDRs are known, a strategy can be devised for inserting these sequences appropriately into a construct containing the DNA for a human antibody variant [50, 51]. The strategy may also employ synthesis of linear DNA fragments based on the reading of CDR sequences. Alemtuzumab is an early example of an antibody whose humanization did not include a chimeric intermediate. In this case, a monoclonal dubbed “Campath-1” was developed to bind CD52 using a mouse system. The hypervariable loops of Campath-1, that contain its CDRs and thereby impart its ability to bind CD52, were then extracted and inserted into a human antibody framework [47].

- *Human antibodies for human therapy derived without using mice:* There are technologies that completely avoid the use of mice or other nonhuman mammals in the process of discovering antibodies for human therapy. Examples of such systems include various “display” methods (primarily phage display) as well as methods that exploit the elevated B-cell levels that occur during a human immune response. Display methods employ the selective principles of specific antibody production but exploit microorganisms (as in phage display; refs. 52, 53) or even cell free extracts (as in ribosome display). These systems rely on the creation of antibody gene “libraries” which can be wholly derived from human RNA isolated from peripheral blood. The immediate products of these systems are antibody fragments, normally Fab or scFv. This means that, although antibody fragments created using display methods are of fully human sequence, they are not full naturally human antibodies. Therefore, processes in essence identical to humanization are used to incorporate and express the derived affinities within a full antibody [54].
- *Antibodies from human patients or vaccines:* Another approach is to exploit the intelligence of the human immune response in the discovery of monoclonal antibodies. Simply put, the natural human immune response works in the same way as that in a mouse or other nonhuman mammal. Therefore, persons experiencing a challenge to their immune system, such as an infectious disease, cancer, or a vaccination, are a potential source of monoclonal antibodies directed at that challenge.

This approach seems especially apt for the development of antiviral therapies that exploit the principles of passive immunity. Variants of this approach have been demonstrated in principle [55] and are finding their way into commercial development.

- *Antibody fragments*: A variety of antibody fragments with binding specificity have been described in the literature, such as scFv (single chain fragment variable) fragments, that are mostly composed of the binding regions of an antibody without any associated heavy chain and therefore effector functions. An Fv fragment is the smallest unit of an immunoglobulin molecule with function in antigen-binding activities. An antibody in a scFv format consists of variable regions of heavy (V_H) and light (V_L) chains, which are joined together by a flexible peptide linker that can be easily expressed in functional form in *E. coli*, allowing protein engineering to improve the properties of scFv such as increase of affinity and alteration of specificity [56]. The generation and various uses of scFv formats can be found in other chapters of this book.

2.1.11 Preferred Isotype of Monoclonal Antibody

Phylogenetically, all isotypes of antibody molecules are important in the immune cascade to provide defense against invading molecules. However, a thorough analysis of functional aspects of antibodies and orchestrated involvement of a cadre of cellular and soluble factors and therapeutic and diagnostic application of antibodies has shown the importance of IgG.

- *Therapeutic uses*: In modern medicine, antibodies are well established as an important class of drugs. In addition, the antibodies with exquisite specificity and affinity towards a specific target have also encouraged their development as delivery vehicles for agents such as radionuclides to target tissues, for radioimmunoimaging and radioimmunotherapy [57]. In this regards, it has been convincingly determined to render the antibody molecule as small as possible yet maintaining its immunologic specificity is highly desirable and progress in this direction has been significant [58]. The small antigen-binding molecules such as scFv antibodies offer several advantages over a whole antibody molecule in therapeutic applications [59, 60]. The smaller fragments allow these molecules to penetrate more rapidly and evenly to tumors and other tissue in comparison to the whole antibodies. To date there are more than 20 monoclonal antibodies that have been approved for therapeutic uses of cancer alone [56]. Generally, antibody fragments can be utilized for the preparation of immunotoxins, therapeutic gene delivery, and as anticancer intrabodies. Antibody fragments can be fused to a range of toxins such as cytotoxic proteins

[61, 62], radionuclides [63], or drugs [64]. Once fused, these immunotoxins could specifically deliver their agents towards cancer antigen-presenting cells.

- *Diagnostic uses:* Recent progress in antibody engineering together with the microbial expression systems has made mAbs relatively affordable so large-scale quantities can be made. Moreover, tags or peptides attached to the antibodies could allow the purification of antibody fragments that can bring homogenous, well-defined, and active proteins to the diagnostic clinic [56].

In general, mAbs for diagnostic purposes do not need to be processed as carefully as mAbs designed for therapeutic uses. For diagnostic purposes, mAbs can bind to a variety of antigens such as haptens, proteins, and also whole pathogens, and they can as well be used in the enzyme-linked immunosorbent assay (ELISA; refs. [65, 66]). The detection of scFv forms can be done using secondary antibody recognizing specific tag that is already fused to the C- or N-terminus of scFv. A number of tags have been used previously, such as c-myc [67] or E-tag (Pharmacia). Due to improper folding of soluble scFv (single-chain fragment variable), they can be easily inactivated during the coating step on the microtiter plates. This was caused by the lack of constant domains of heavy and light chains. In order to overcome this difficulty, (especially during the selection of scFv (single-chain fragment variable) from phage display libraries), scFv (single-chain fragment variable) in a phage format can be used in ELISA assay, which means that the scFv (single-chain fragment variable) remains attached to the coat protein of filamentous phage. By applying this step, it may improve and stabilize protein folding as the phage may mimic missing constant domains of the original antibody [68].

- *Class Switching:* The first humoral immune response to an invading antigen is typically an IgM isotype, which then switches to IgG or IgA or IgE. This can be exploited to identify if the humoral immune response is to a recent exposure to the immunizing source. However, certain antigens such as glycans and gangliosides in particular, seem to elicit IgM isotypes only. For therapeutic and diagnostic purposes, IgG isotypes are preferred due to their smaller size and stability compared to IgM. For these reasons, efforts have been made, with mixed outcomes, to class switch antibodies from IgM to IgG to enhance their applicability.

Naïve mature B cells produce both IgM and IgD, which are the first two heavy chain segments in the immunoglobulin gene locus. After activation by antigen, these B cells subsequently proliferate. If these activated B cells encounter specific signaling molecules via their CD40 and cytokine receptors (both modulated by

T helper cells), they undergo AID-controlled antibody class switching to produce IgG, IgA, or IgE antibodies.

Immunoglobulin class switching (or isotype switching or isotypic commutation or class switch recombination (CSR)) is a biological mechanism controlled by AID and other enzymes that changes a B cell's production of antibody from one class or isotype to another such as changing an initial IgM response to a more durable IgG response [69, 70]. During this process, the constant region portion of the antibody heavy chain is changed, but the variable region of the heavy chain stays the same (the terms "constant" and "variable" refer to changes or lack thereof between antibodies that target different epitopes). Since the variable region does not change, class switching does not affect antigen specificity. Instead, the antibody retains the same affinity for the same antigens, but can interact with different effector molecules.

The mechanism of CSR consists of making double-stranded breaks in antibody gene DNA at conserved nucleotide motifs, called switch (S) regions, which are upstream from the gene segments that encode the constant regions of antibody heavy chains; these are located adjacent to all heavy chain constant region genes with the exception of the δ -chain. DNA is nicked and broken at two selected S-regions by the activity of a series of enzymes. The intervening DNA between the S-regions is subsequently deleted from the chromosome, removing unwanted μ or δ heavy chain constant region exons and allowing substitution of a γ , α or ϵ constant region gene segment. The free ends of the DNA are rejoined by a process called nonhomologous end joining (NHEJ) to link the variable domain exon to the desired downstream constant domain exon of the antibody heavy chain [71]. In the absence of NHEJ, free ends of DNA may be rejoined by an alternative pathway biased toward microhomology joins [72]. With the exception of the μ and δ genes, only one antibody class is expressed by a B cell at any point in time.

Class switching occurs after activation of a mature B cell via its membrane-bound antibody molecule (or B cell receptor) to generate the different classes of antibody, all with the same variable domains as the original antibody generated in the immature B cell during the process of V(D)J recombination, but possessing distinct constant domains in their heavy chains [73]. During class switching, since the constant region of the immunoglobulin heavy chain changes but the variable regions, and therefore antigenic specificity, stays the same this then allows different daughter cells from the same activated B cell to produce antibodies of different isotypes or subtypes (e.g., IgG1, IgG2) [74].

2.1.12 Antibody Affinity

Much has been made of antibody affinity and an important decision in this regard is the actual use of the antibody itself. If a naked antibody is required, either used as monotherapy or as cocktail combinations, then a natural affinity may be preferred since the

on/off rate of an antibody with its antigen invokes various elements of the immune response. However, if the antibody is used as a vehicle to deliver a toxic component, such as with drug-conjugates, then high affinities would be preferred to help insure the toxic component finds the right target and not bystander cells.

Many factors contribute to successful tumor therapy and targeting by antibodies. Besides properties of the tumor tissue and general antibody pharmacology, a relationship exists between an antibody and its antigen that can shape penetration, catabolism, specificity, and efficacy. The affinity and avidity of the binding interactions play critical roles in these dynamics. It has been well documented that affinity can limit penetration of antibody into tumors, especially large or poorly vascularized tumors. However, it must be predetermined if homogenous distribution is necessary for their application. For example, for imaging and diagnosis, it is adequate to use a high-affinity mAb as resulting heterogeneous distribution will achieve the goal of tumor detection. However, specificity and clearance, both affected by avidity and valency, are crucial to systemic clearance in the appropriate imaging timeframe as well as limiting side effects that radiation may have on other tissues. Therefore, antigen selection is a critical factor for internalization and catabolism of mAbs. The relative rates of antigen recycling and dissociation are important in mAb penetration into tumors. Therefore, in applications dependent on targeting every cell of a tumor, the mAb needs to dissociate before it is internalized and degraded. In the case of ADCC, a slow internalizing antigen would be the best target. However, if one is trying to deliver a cytotoxic agent to the cytoplasm of cells in a limited region of a tumor, such as the vasculature, a mAb with slow dissociation targeting a rapidly recycling antigen would be appropriate. These are just simple examples of the interplay of affinity, avidity, and efficacy in tumor targeting [75].

2.1.13 Preclinical and Clinical Limitations

To enter a clinical setting with any human mAb, stating the obvious, there must be a compelling reason to do so. This reason is provided by the preclinical data and the more data available then intelligent decision making can be done to minimize time and expense. Too often investigators attempt to begin clinical trials with minimal data that are nonoptimal and could derail the clinical trial process.

Critical to the early clinical trials with human mAbs is patient recruitment. Those patients best suited to respond to the therapy should be included in trial design. Also, another practical limitation in clinical trials is the availability of enough antibodies to treat all the patients and once approved, then sufficient supplies must be available to meet the demands.

2.1.14 Lymph Nodes

Lymph nodes are among the organs most commonly used for biopsy and diagnosis and are routinely removed from patients. Lymph nodes are connected to the lymphatic pathway, both afferent

and efferent lymphatics, and the blood circulatory system and are used to monitor and regulate major immune responses. Therefore, lymph nodes represent a model system that can be developed to help understand the various immune responses that occur. In the generation of natural human antibodies to cancer antigens one approach is to exploit the intelligence of the sentinel lymph node immune response in cancer patients [76]. In this way lymph nodes are windows into the natural anticancer immune response. These cancer patients have an active immune response and lymph nodes, especially those containing tumor metastasis, are ideal sources for analyzing a specific antibody immune response [77].

In lymph nodes, antigen driven immunoselection of optimal B cells occurs in germinal centers where affinity maturation, class switching, and somatic hypermutation events take place [78]. Specifically, in lymph node germinal centers of cancer patients, major antigen-driven V-D-J gene rearrangements occur whereby antibodies to various tumor-associated antigens have been generated. In this way, the intelligence of the natural immune response has acted like a drug discovery program in which the human immune response has, in essence, identified, located, and responded to clinically interesting tumor antigens [76].

Lymph node germinal centers vary in size, increasing dramatically with antigen challenge [78]. The lymphoid cells of germinal centers consist of small, medium-sized, and large lymphocytes in various degrees of maturation, stimulation, and proliferation. An analysis of the antibody repertoire of these B cells could be useful in understanding the limitations and broadness of natural antibodies to tumor antigens. Immunohistochemical analysis has shown these human antibodies recognize antigens that are highly restricted to tumor cells and tissues [79].

Migrating lymphocytes filter through lymph nodes and, if necessary, stay and develop into germinal centers through clonal selection and expansion. Affinity maturation may occur at this time as well as class switching, which is cytokine driven. In isotype class switching, specificity remains the same though the heavy chains change. Since these responses are antigen driven they therefore constitute “antigen-specific modulation(s).” The antigen must constantly be present to keep driving germinal center development. In this respect various questions can be asked such as what is the nature of the antigen and how does it drive somatic hypermutation (v-gene editing) and affinity maturation in germinal centers? Is the percent time spent in the presence of antigen related to affinity maturation? What is the role of dendritic cell processing of the antigen? Is there any antigen processing outside of the lymph node whereby “armed” dendritic cells enter the node for germinal center development? How many derived lymph node antibodies are cell specific? How many different antibodies can be generated by involved nodes? What are the relative affinities of antibodies derived from separate germinal centers?

In a normal, unreactive lymph node there are about 20 germinal centers. In a reactive lymph node there can be up to 100 germinal centers. The average germinal center size is approximately 0.1 cm in length and $\sim 0.001 \text{ cm}^3$. A normal sized lymph node is about $0.6 \times 0.3 \times 0.3 \text{ cm} = 0.054 \text{ cm}^3$ and a reactive lymph node is $1.2 \times 0.8 \times 0.6 = 0.57 \text{ cm}^3$. There are about 6×10^8 lymphocytes in each unreactive lymph node and about 6.5×10^9 cells in a reactive lymph node. As such there are plenty of activated B cells available. From this, one interesting question is this: are the germinal centers of reactive lymph nodes of cancer patients recognizing the same antigen or different antigens or perhaps different epitopes on the same antigen?

With all these potential germinal centers then what is the B cell repertoire of this anticancer lymph node response? What can we learn about the natural human immune response from these B cells? Can any insight be gained in analyzing the theoretical limits of the regional draining lymph node immune response? Essentially, what is the human anticancer immune repertoire and what predictions can we make from this? Overall, the answers to these questions suggest that good antibody responses are generated to a class of antigens that impact tumor biology. However, since tumors do grow then other elements (e.g., cytotoxic T cells, various cytokines) are necessary to eradicate and/or control tumor cell development.

Lymph nodes are strung together like a string of pearls and those nodes proximal to a draining tumor would have a different germinal center immune response, and therefore different repertoire, than those more distal to the tumor. The location of the lymph node in relation to the primary tumor is important. Also, proximal nodes may have metastases whereas the distal nodes may not have any. As such, then in a draining lymph node echelon, proximal node 1 would be different from distal node 2, node 3, etc. Does the antibody repertoire vary in each lymph node echelon? Also, how does the repertoire vary between different cancers? A lymph node response may be different in colon cancer patients compared to, say, melanoma.

Lymph node staging does play a role in the overall diagnosis of a patient's immune response. Are there any rules in the development of these anticancer germinal centers that impact on immunoselection for an anticancer response? Furthermore, what sort of anticancer response occurs in nodes that are microscopic only in extent and not detectable grossly? Related to this is what is the antigen threshold or concentration necessary for generating an immune response? Micrometastatic foci in lymph nodes trigger immune responses as measured by GC development. How big (i.e., number of cells) are these foci and when does occult foci turn into non-occult foci? Tumor cell doubling time is critical and has an advantage of rapid growth (fast cell cycle times) so they can both stimulate an immune response and "outgrow" the insufficient immune response retaliation.

In our studies a panel of human mAbs has been generated from B-cells isolated from regional draining lymph nodes of cancer patients. The recognized antigens are various cell surface proteins and gangliosides. Animal models of biodistribution and tumor regression suggest these human mAbs have bioactivity in immunotargeting and immunoregulation of cancer [34]. Clinical data from phase I/II trials with cancer patients suggests these lymph node-derived human mAbs may show patient benefits [3]. Since these natural human antibodies have all been obtained from reactive lymph nodes of cancer patients this suggests that interesting V-D-J antibody gene rearrangements have occurred, most likely driven by exposure to various tumor antigens. Such a panel of natural human antibodies may have utility in the oncology clinic.

Some advantages of exploiting the natural lymph node human antibody repertoire is being able to reintroduce a natural antibody back into patients since it should be well tolerated (similar to IVIG preparations; ref. 80). In contrast, synthetic library antibodies, though human, may present novel immunoreactive epitopes on the developed antibody that could have contraindications.

Based on the above discussions it should be noted that not all regional draining lymph nodes are the same. Below is a list of key characteristics that can differentiate various technical lymph node features.

1. Size (occult vs. gross tumor involvement).
2. Number and location:
 - (a) Sentinel vs. secondary level.
 - (b) Ipsilateral vs. bilateral.
3. Extent of nodal invasion by metastasis:
 - (a) Clinical:
Mobility vs. fixed, edema.
 - (b) Histopathologic:
Pericapsular sinus vs. replacement.
Extracapsular invasion.
Vascular, lymphatic, neural, soft tissue invasion.
4. Biologic:
 - (a) Historical growth rate.
 - (b) Synchronous vs. metachronous with primary tumor.
 - (c) Growth potential of occult metastasis.

In summary, to get a clear overview of the lymph node-derived anticancer antibody response a systematic analysis of the antibody repertoire in each germinal center needs to be undertaken. Furthermore, this should be done for each sequential lymph node that is draining a

tumor. When combining this data from separate cancers, such as melanoma lymph nodes compared to breast cancer lymph nodes, then this information may provide insights in how to better treat and regulate cancer based on the natural human anticancer response.

2.1.15 Biological Limitations

Though not technical limitations per se there are inherent biological limitations in generating human mAbs. The most important biological limitation is the relative antigenicity of the target epitope on the antigen of interest. Humans may not have the genetic repertoire in their immune response to recognize certain epitopes so in this respect they are immunologically blind. In other words, what are the immunological fitness of the antigen and the immunological fitness of the host? Perhaps synthetic libraries can overcome these limitations. Even so, the generated synthetic antibody may itself present novel immunogenic epitopes on the antibody itself and result in anti-idiotypic antibodies that can potentially neutralize the benefits of the engineered antibody.

2.2 Limitations of Manufacturing Issues

No matter what type of antibody is eventually chosen it will have to be manufactured and if the goal is as a diagnostic and/or therapeutic, then the antibody must be manufactured under Good Manufacturing Practices (GMP) conditions, all subject to the rules and regulations of the Food and Drug Administration (FDA). Technical limitations of FDA-sponsored antibody manufacturing center on amounts required. The concerns and technical issues of making grams of antibody are significantly different from those necessary in the making of kilograms of antibody, amounts needed for therapeutic applications where large amounts of GMP qualified product are FDA required. If only gram quantities are needed then this can readily be done on the lab bench. If kilograms are needed then significant expense and time is necessary for manufacture. For kilogram production the antibody genes (chimeric, humanized, or fully human) are typically inserted in Chinese hamster ovary (CHO) cells for manufacturing, though other cell types are being explored as a cheaper manufacturing source.

2.2.1 Production Costs

mAbs are large (150 kDa) multimeric proteins containing numerous disulphide bonds and posttranslational modifications such as glycosylation. They need a sophisticated eukaryotic machinery to be produced in active form. Moreover, most studies have shown that these antibodies have to be injected in large amounts to achieve clinical efficacy, e.g., 8–16 doses of 375 mg/m²; that represents a total amount of 6–12 g per patient for Rituximab. Consequently, the production of therapeutic antibodies necessitates the use of very large cultures of mammalian cells followed by extensive purification steps, under GMP conditions, leading to

extremely high production costs which limits the wide use of these drugs. Several alternative production systems in microorganisms and plants are being evaluated at the moment, which might lead to significant progress in the near future [81, 82].

2.2.2 *Screening Limitations*

For screening purposes a reproducible target is necessary. For some applications the human mAbs are screened against tissue samples. In some cases, the availability of rare tissues is prohibitive, as well as long term cultures are not the same as the original early passage cell lines. While it is feasible to use genetically engineered targets that pose no quantity limitations, tissue extracts or biopsy tissues are limited in supply for screening.

2.2.3 *Effector Function Limitations*

In addition to the binding region of antibodies the heavy chains, or Fc portion, are equally important in therapeutic applications. With a proper Fc region then other important elements of the immune system, such as T cells and dendritic cells, can be utilized for a more complete, durable, and efficient immune response.

mAbs can have various modes of actions *in vitro*, and the actual mode of action once injected in patients is not always clear [83]. The simplest mode of action is mere binding of the antibody to its antigen, thereby interfering with antigen activity and interaction with binding partners. The antigen can be a soluble ligand, and examples of such antibodies include infliximab, adalimumab, and certolizumab (anti-TNF α) or bevacizumab (anti-vascular endothelial growth factor). On the other hand, the antibody may target a receptor displayed at the cell surface, block its interaction with a ligand, interfere with a multimerization process or trigger internalization of receptors, or apoptosis of targeted cells. Examples of such antibodies include cetuximab and panitumumab [anti-EGFR (epidermal growth factor receptor) or HER1 (human epidermal growth factor receptor)] and trastuzumab (anti-HER2; ref. 84).

Data has been published demonstrating that ADCC plays a major role in the *in vivo* efficacy of mAbs, and the relationship between Fc γ R polymorphisms and clinical response to antibodies for therapy have been examined [85, 86]. Thus, triggering of ADCC by therapeutic antibodies faces several limitations. One of them is the glycosylation of CH2 domain (Asn 297) in the Fc region. This modification is extremely important as it modulates the affinity of the Fc for Fc γ RIIIa, thereby modifying the *in vivo* efficacy of antibodies [87]. The nature of the carbohydrate moiety is dependent on which enzymes are expressed by the cell line used for antibody production [88]. As a result, several efforts have been made to glycoengineer the Fc of therapeutic antibodies to make them more human like. mAbs produced in CHO cells will have rodent glycosylation of the Fc region. In particular, the residue fucose, which branches off the first mannose residue attached to Asn-297 needs to be removed for optimal integration with the human effector system.

Similar studies are also being conducted in nonmammalian expression systems such as yeast, plant, and moss [89–91].

2.3 Ethical Limitations

Ethical limitations in making hmAbs are varied and quite subjective. As such it is difficult to develop a consensus understanding of all the issues involved. Compounding this is the reality of a moving target in that what may be considered ethical today may not be so tomorrow. Nevertheless, there is common ground to begin a discussion.

2.3.1 Sources of B-Cells

Not all sources of B cells are ethically equal. Two major approaches to designing and making hmAbs are either through a synthetic route or a natural route. Simply stated the difference is in creating mAbs or finding natural mAbs. This decision is centered on the antigen and if the antigen is known, such as in CD20 or VEGF receptors, then a synthetic route may be the best way to go. However, if the antigen is unknown and you are looking for specificity to certain cell types (such as cancer cells) then a natural route will be preferred in generating a human antibody and in this respect the patient's own immune response defines the antigen target.

In addition to the source of lymphocytes, the patient's consent is important for making natural antibodies. However, if making synthetic antibodies then patient consent may not be necessary (such as in the case of using xenomice for immunizations). If a patient donated PBL for research and something useful results should the patient be compensated? (It should be noted that Henrieta Lacks, from whom HeLa cells were derived, was never compensated for her donation to cancer research.)

Another ethical dilemma in obtaining B cells is getting them from cadavers or perhaps inmate or military "volunteers." Governments have used military (or civilian) volunteers to immunize/vaccinate to antigens and these developed B cells can be used for hmAb development.

2.3.2 Exploiting "Nature's Experiments"

Some consider any exploitation to be unethical. However, exploiting what nature has provided should be looked at with an open mind. Autoimmune responses, including those anticancer responses that can be considered "autoimmunity" imply a patient's own immune response is generating the unwanted antibody. Essentially, autoimmunity can be thought of as a passive immunization in that the patient's own immune response is generating the antibody. Though removing the B cells making the antibody of interest is a straightforward process care should be taken when obtaining these lymphocytes.

2.3.3 Informed Consent vs. Discarded Tissues

There have been several debates that have dealt with "for" and "against" the use of leftover body material for scientific research purposes, and whether consent is needed for use of such materials

for research [92–95]. It is apparent that during diagnostic procedures larger samples of body fluids and tissues are usually collected than strictly necessary for primary testing, “just in case.” The advantage is, of course, that the patient does not need to be re-biopsied if further testing is required. Furthermore, therapeutic surgical procedures usually yield large samples from which only a part is needed for diagnostic confirmation. All this leads to a potentially large volume of leftover samples, which are usually stored in laboratories for a period to serve the direct interest of the patient. Permission for this use is implicit in the standard consent obtained from patients for the diagnosis and treatment of their disease. However, when the current disease period has ended a dilemma emerges with regard to this leftover body material: to discard or to keep? To discard saves costs and space, but to keep the material also has many advantages, not least for patients themselves. During the course of a disease the pathologist often has to return to such material for additional or new diagnostic procedures or prognostic tests and having material around will make this easier. This applies especially to histopathological material but it also applies to a lesser extent to body fluids.

Furthermore, the leftover material is a valuable source for research and teaching and for control samples for diagnostic and prognostic purposes. However, it has been argued increasingly that patients should give their consent for this type of reuse [92]. This may vary from “no objection” to a system where the patient is asked on each occasion the material is reused. It is easy to imagine that the latter system will inevitably lead to the material no longer being available for further use, as patients will move and die, and in the end family members will be more and more difficult to trace. Any system requiring any kind of consent will take time and money that might be better spent on research itself. Furthermore, some patients will refuse. Together, these facts will hinder the reuse of leftover material for the worthy purposes. Overall, these materials serve the advancement of medicine and thereby humankind in general and should be studied instead of discarded. Therefore it has been argued that no consent should be needed for using leftover body material for scientific purposes [93].

To further complicate matters the question raised is which problem is being solved by introducing a consent system? The old system, under which specific consent was not obtained, has not caused any major concerns. The worst documented affair is the (noncommercial) provision of meninges to a company preparing meninx allografts for medical use. Even in the Alder Hey affair [94] in which a British hospital was criticized for retaining children’s organs after autopsy without the knowledge of the parents, the problem was not so much the storage and reuse of the material as the fact that it had not been used for the intended diagnostic

procedures. Thus, why then should one take draconian measures to protect patients' rights that are apparently not endangered?

There are at most three proper arguments why patients might refuse consent to the use of their leftover or discarded material. First, if all the leftover material is used for other purposes there might be none left if the patients themselves need more diagnostic procedures during the course of their disease. That is a practical issue that can be solved by ensuring that a defined quantity of material has to remain when reusing material. Second, privacy may be breached. Again, the material should be coded or used anonymously. However, to ascertain the significance of the research results, the researcher should be able to access the clinical information of the subject without knowing his/her identity. The third argument is the "right of self determination": that the material belongs to the patient, who therefore has the right to decide what is done with it. In the case of leftover body material this should not be the overriding principle. Current knowledge used to diagnose and treat today's patients has been obtained from research using data and material from patients from the past. Current diagnostic procedures can be performed reliably only by including appropriate positive and negative control samples from previous patients. Likewise, future patients can be optimally diagnosed and treated only by using material from today's patients. It is suggested that the principle of solidarity should take priority over the right of self-determination.

Furthermore, there are valid reasons as to why it could be preferred to not ask for consent. These include: (a) less material will be available for scientific purposes, (b) involvement of bureaucracy, (c) right of self determination is relative, especially for leftover material, (d) principle of solidarity—helping others—is more important, (e) lack of consent has not caused problems in the past, (f) patients' privacy and interests can be safeguarded without a consent system, (g) practical alternative for leftover body material is to discard it: that helps no one. It should be noted that experience with tissue banks where consent has been obtained from patients for further wider use have been favorable [96].

It is also argued that there are ethical reasons for obtaining consent. (a) Consent is important because information derived from tissue specimens can harm the subject, because it can reveal health information which the individual may find distressing and which may have implications for that person's family, reproduction, insurance, and employment. However, strict adherence and coding of specimens should circumvent this problem. By giving consent, an individual voluntarily takes on the risk and, if he or she is rational, will ensure risk is minimized to a reasonable level. (b) Consent is important to respect the autonomy of mature people. Each mature person should be the author of his or her own life. Each person has values, plans, aspirations, and feelings about how

that life should go and, as such, these values may collide with research goals. However, specimens removed from a subject for his or her health benefit and left after appropriate clinical use to benefit the subject is not expected to be of use to the donor, and its use in research is more prudent than discarding or destroying it [97].

2.3.4 Ability to Trace Patient Information

In order to reap the highest benefit of results of research conducted on human specimens, it is important to have clinical information of the subject who donated the specimen. Retrieval of clinical information particularly at the time of specimen collection is important. To assure patient anonymity this information must be kept unlinked to the donor's identity. In other words, the specimen and the clinical information of the donor are not linked and the donor is unknown to the end user of the material.

3 Summary

In the broadest sense there are no longer any technical limitations to making human mAbs. Biological issues involving the type and nature of either a synthetic or a natural antibody, advantages of various B cell immunological compartments, and various assays needed to qualitate and quantitate mAbs have essentially been solved. If the target antigen is known then procedures to optimize antibody development can be readily planned out and implemented. When the antigen or target is unknown and specificity is the driving force in generating a human mAb then considerations about the nature and location of the B cell making the sought after antibody become important. And, therefore, the person the B cell is obtained from can be an ethical challenge and a limitation. For the sources of B cells special considerations must be taken to insure the anonymity and privacy of the patient. In many cases informed consent is adequate for antibody development as well as using discarded tissues. After the antibody has been generated then manufacturing technical issues become important that greatly depend upon the amounts of mAb required. For kilogram quantities then special considerations for manufacturing that include FDA guidelines will be necessary.

References

1. Teicher BA, Chari RVJ (2011) Antibody conjugate therapeutics: challenges and potential. *Clin Cancer Res* 17:6389–6397
2. Nelson AL, Dhimolea E, Reichert JM (2010) Development trends for human monoclonal antibody therapeutics. *Nat Rev Drug Discov* 9:767–774
3. Weiner LM, Surana R, Wang S (2010) Monoclonal antibodies: versatile platforms for cancer immunotherapy. *Nat Rev Immunol* 10:317–327
4. Bradbury ARM, Sidhu S, Dubel S, McCafferty J (2011) Beyond natural antibodies: the power of in vitro display technologies. *Nat Biotechnol* 29:245–254

5. Griffiths AD, Duncan AR (1998) Strategies for selection of antibodies by phage display. *Curr Opin Biotechnol* 9:102–108
6. Miraglia S, Swartzman EE, Mellentin-Michelotti J, Evangelista L, Smith C, Gunawan II, Lohman K, Goldberg EM, Manian B, Yuan PM (1999) Homogeneous cell- and bead-based assays for high throughput screening using fluorometric microvolume assay technology. *J Biomol Screen* 4:193–204
7. Hooper JD, Zijlstra A, Aimes RT, Liang H, Claassen GF, Tarin D, Testa JE, Quigley JP (2003) Subtractive immunization using highly metastatic human tumor cells identifies SIMA135/CDPC1, a 135 kDa cell surface phosphorylated glycoprotein antigen. *Oncogene* 22:1783–1794
8. Zijlstra A, Testa JE, Quigley JP (2003) Targeting the proteome/epitome, implementation of subtractive immunization. *Biochem Biophys Res Commun* 303:733–744
9. Williams AF, Galfre G, Milstein C (1977) Analysis of cell surfaces by xenogeneic myeloma-hybrid antibodies: differentiation antigens of rat lymphocytes. *Cell* 12:663–673
10. Bernard A, Boumsell L (1984) The clusters of differentiation (CD) defined by the first international workshop on human leucocyte differentiation antigens. *Hum Immunol* 11:1–10
11. Hellstrom I, Garrigues HJ, Garrigues U, Hellstrom KE (1990) Highly tumor-reactive, internalizing, mouse monoclonal antibodies to Le(y)-related cell surface antigens. *Cancer Res* 50:2183–2190
12. Israeli RS, Powell CT, Fair WR, Heston WD (1993) Molecular cloning of a complementary DNA encoding a prostatespecific membrane antigen. *Cancer Res* 53:227–230
13. Carter P, Smith L, Ryan M (2004) Identification and validation of cell surface antigens for antibody targeting in oncology. *Endocr Relat Cancer* 11:659–687
14. Lander ES, Linton LM, Birren B, Nusbaum C, Zody MC, Baldwin J, Devon K, Dewar K, Doyle M, FitzHugh W et al (2001) Initial sequencing and analysis of the human genome. *Nature* 409:860–921
15. Venter JC, Adams MD, Myers EW, Li PW, Mural RJ, Sutton GG, Smith HO, Yandell M, Evans CA, Holt RA et al (2001) The sequence of the human genome. *Science* 291:1304–1351
16. Carter P (2001) Improving the efficacy of antibody-based cancer therapies. *Nat Rev Cancer* 1:118–129
17. Milenic DE (2002) Monoclonal antibody-based therapy strategies: providing options for the cancer patient. *Curr Pharmacol Des* 8:1749–1764
18. Presta LG (2002) Engineering antibodies for therapy. *Curr Pharm Biotechnol* 3:237–256
19. Glennie MJ, van de Winkel JG (2003) Renaissance of cancer therapeutic antibodies. *Drug Discov Today* 8:503–510
20. Ross J, Gray K, Schenkein D, Greene B, Gray GS, Shulok J, Worland PJ, Celniker A, Rolfe M (2003) Antibody-based therapeutics in oncology. *Expert Rev Anticancer Ther* 3:107–121
21. Janeway CA Jr, Medzhitov R (2002) Innate immune recognition. *Annu Rev Immunol* 20:197–216
22. Brandlein S, Vollmers HP (2004) Natural IgM antibodies, the ignored weapons in tumour immunity. *Histol Histopathol* 19:897–905
23. Vollmers HP, Brandlein S (2002) Natural antibodies and cancer. *New Biotechnol* 25:294–298
24. Bohn J (1999) Are natural antibodies involved in tumour defence? *Immunol Lett* 69:317–320
25. Cyster JG (1999) Chemokines and cell migration in secondary lymphoid organs. *Science* 286:2098–2102
26. Lapidot T et al (1994) A cell initiating human acute myeloid leukaemia after transplantation into SCID mice. *Nature* 367:645–648
27. Scadden DT (2006) The stem-cell niche as an entity of action. *Nature* 441:1075–1079
28. Kurosaka D, LeBien TW, Pribyl JA (1999) Comparative studies of different stromal cell microenvironments in support of human B-cell development. *Exp Hematol* 27:1271–1281
29. Corcione A, Benvenuto F, Ferretti E, Giunti D, Cappiello V, Cazzanti F, Rizzo M, Gualandi F, Mancardi GL, Pistoia V, Uccelli A (2006) Human mesenchymal stem cells modulate B-cell functions. *Blood* 107:367–372
30. Kotlan B, Simsa P, Teillaud JL, Fridman WH, Toth J, McKnight M, Glassy MC (2005) Novel ganglioside antigen identified by B cells in human medullary breast carcinomas: the proof of principle concerning the tumor-infiltrating B lymphocytes. *J Immunol* 175:2278–85
31. Westermann J, Pabst R (1992) Distribution of lymphocyte subsets and natural killer cells in the human body. *Clin Investig* 70:539–544
32. Koda K, Glassy MC, McKnight ME, Saito N, Dan M, Fukao K, Nakajima N (1998) Human monoclonal antibody SK-1 immunotargeting for rectal carcinoma. *Int J Immunother* 14:153–161
33. Koda K, Glassy MC, McKnight ME, Yasutomi J, Saito N, Dan M, Nakajima N (2001) Immunotherapy for recurrent colorectal cancers with human monoclonal antibody SK-1. *Anticancer Res* 21:621–628

34. Glassy MC, McKnight M (2005) Requirements for human antibody cocktails for oncology. *Expert Opin Biol Ther* 5:1333–1338
35. Glassy MC, Hagiwara H (2009) Summary analysis of the pre-clinical and clinical results of brain tumor patients treated with primumab. *Hum Antibodies* 17:127–137
36. Hagiwara H, Aotsuka Y, Yamamoto Y, Miyahara J, Mitoh Y (2001) Determination of the antigen/epitope that is recognized by human monoclonal antibody CLN-IgG. *Hum Antibodies* 10:77–82
37. Goldsmith SJ, Signore A (2010) An overview of the diagnostic and therapeutic use of monoclonal antibodies in medicine. *Q J Nucl Med Mol Imaging* 54:574–581
38. Brekke OH, Loset GA (2003) New technologies in therapeutic antibody development. *Curr Opin Pharmacol* 3:544–550
39. Sidhu SS, Fellouse FA (2006) Synthetic therapeutic antibodies. *Nat Chem Biol* 2:682–688
40. Sanz L, Blanco B, Alvarez-Vallina L (2004) Antibodies and gene therapy: teaching old “magic bullets” new tricks. *Trends Immunol* 25:85–91
41. Chambers RS (2005) High-throughput antibody production. *Curr Opin Chem Biol* 9:46–50
42. Hoogenboom HR (2005) Selecting and screening recombinant antibody libraries. *Nat Biotechnol* 23:1105–1116
43. Cabaugh CW, Almargo JC, Pogson M, Iverson B, Georgiou G (2008) Synthetic antibody libraries focused towards peptide ligands. *J Mol Biol* 378:622–633
44. Hansel TT, Kropshofer H, Singer T et al (2010) The safety and side effects of monoclonal antibodies. *Nat Rev Drug Discov* 9:325–338
45. Chintalacheruvu KR, Morrison SL (1995) Chimeric antibodies: production and applications. *Methods* 8:73–82
46. Chadd HE, Chamow SM (2001) Therapeutic antibody expression technology. *Curr Opin Biotechnol* 12:188–194
47. Riechmann L, Clark M, Waldmann H, Winter G (1988) Reshaping human antibodies for therapy. *Nature* 332:323–327
48. Bernett MJ, Karki S, Moore GL, Leung IW, Chen H, Pong E, Nguyen DH, Jacinto J, Zalevsky J, Muchhal US, Desjarlais JR, Lazar GA (2010) Engineering fully human monoclonal antibodies from murine variable regions. *J Mol Biol* 396:1474–1490
49. Norderhaug L, Olafsen T, Michaelsen TE et al (1997) Versatile vectors for transient and stable expression of recombinant antibody molecules in mammalian cells. *J Immunol Methods* 204:77–87
50. Kashmiri SV, De Pascalis R, Gonzales NR, Schlom J (2005) SDR grafting—a new approach to antibody humanization. *Methods* 36:25–34
51. Hou S, Li B, Wang L, Qian W, Zhang D, Hong X, Wang H, Guo Y (2008) Humanization of an anti-CD34 monoclonal antibody by complementarity-determining region grafting based on computer-assisted molecular modeling. *J Biochem* 144:115–120
52. Kempeni J (1999) Preliminary results of early clinical trials with the fully human anti-TNF α monoclonal antibody D2E7. *Ann Rheum Dis* 58:170–172
53. Rau R (2002) Adalimumab: a fully human anti-tumour necrosis factor α monoclonal antibody in the treatment of active rheumatoid arthritis: the initial results of five trials. *Ann Rheum Dis* 61:70–73
54. Ducancel F, Muller BH (2012) Molecular engineering of antibodies for therapeutic and diagnostic purposes. *MAbs* 4(4):445–57, PMID: 22684311
55. Stacy JE, Kausmally L, Simonsen B, Nordgard SH, Alsøe L, Michaelsen TE, Brekke OH (2003) Direct isolation of recombinant human antibodies against group B *Neisseria meningitidis* from scFv expression libraries. *J Immunol Methods* 283:247–259
56. Ahmad ZA, Yeap SK, Ali AM, Ho WY, Alitheen NBM, Hamid M (2012). scFv antibody: principles and clinical application. *Clin Dev Immunol* 2012, Article ID 980250, p 15
57. Goldenberg DM (2002) Targeted therapy of cancer with radiolabeled antibodies. *J Nuclear Med* 43:693–713
58. Hudson PJ, Souriau C (2003) Engineered antibodies. *Nature Med* 9:129–134
59. Colcher D, Pavlinkova G, Beresford G, Booth BJM, Choudhury A, Batra SK (1998) Pharmacokinetics and biodistribution of genetically-engineered antibodies. *Q J Nucl Med* 42:225–241
60. Hudson PJ (1999) Recombinant antibody constructs in cancer therapy. *Curr Opin Immunol* 11:548–557
61. Chowdhury PS, Viner JL, Beers R, Pastan I (1998) Isolation of a high-affinity stable single-chain Fv specific for mesothelin from DNA-immunized mice by phage display and construction of a recombinant immunotoxin with antitumor activity. *Proc Natl Acad Sci USA* 95:669–674
62. Liu SY, Eary JF, Petersdorf SH et al (1998) Follow-up of relapsed B-cell lymphoma patients treated with iodine-131-labeled anti-CD20 antibody and autologous stem-cell rescue. *J Clin Oncol* 16:3270–3278

63. Chari RVJ (1998) Targeted delivery of chemotherapeutics: tumor-activated prodrug therapy. *Adv Drug Deliv Rev* 31:89–104
64. Gattenlöhner S, Jörissen H, Huhn M, et al. (2010) A human recombinant autoantibody-based immunotoxin specific for the fetal acetylcholine receptor inhibits rhabdomyosarcoma growth in vitro and in a murine transplantation model. *J Biomed Biotechnol* 2010, Article ID 187621, p 11
65. Luka J, Arlen PM, Bristol A (2011) Development of a serum biomarker assay that differentiates tumor-associated MUC5AC (NPC-1C ANTIGEN) from normal MUC5AC. *J Biomed Biotechnol* 2011, Article ID 934757, p 8
66. Gupta RK, Morton DL (2004) Prognostic utility of a glycoprotein tumor-associated antigen (TA90) specific immune complex assay in patients with cancer. *Clin Appl Immunol Rev* 4:395–410
67. Hoogenboom HR, Griffiths AD, Johnson KS, Chiswell DJ, Hudson P, Winter G (1991) Multi-subunit proteins on the surface of filamentous phage: methodologies for displaying antibody (Fab) heavy and light chains. *Nucleic Acids Res* 19:4133–4137
68. Griep RA, van Twisk C, Kerschbaumer RJ et al (1999) pSKAP/S: an expression vector for the production of single-chain Fv alkaline phosphatase fusion proteins. *Protein Expr Purif* 16:63–69
69. Durandy A (2003) Activation-induced cytidine deaminase: a dual role in class-switch recombination and somatic hypermutation. *Eur J Immunol* 33:2069–2073
70. Casali P, Zan H (2004) Class switching and Myc translocation: how does DNA break? *Nat Immunol* 5:1101–1103
71. Lieber MR, Yu K, Raghavan SC (2006) Roles of nonhomologous DNA end joining, V(D)J recombination, and class switch recombination in chromosomal translocations. *DNA Repair (Amst)* 5:1234–1245
72. Yan CT, Boboila C, Souza EK, Franco S, Hickernell TR, Murphy M, Gumaste S, Geyer M, Zarrin AA, Manis JP, Rajewsky K, Alt FW (2007) IgH class switching and translocations use a robust non-classical end-joining pathway. *Nature* 449:478–482
73. Market E, Papavasiliou FN (2003) V(D)J Recombination and the evolution of the adaptive immune system. *PLoS Biol* 1:e16
74. Stavnezer J, Amemiya CT (2004) Evolution of isotype switching. *Semin Immunol* 16:257–275
75. Rudnick SI, Adams GP (2009) Affinity and avidity in antibody-based tumor targeting. *Cancer Biother Radiopharm* 24:155–161
76. Glassy MC, McKnight ME (1994) Pharming the human lymph node. *Exp Opin Invest Drugs* 3:1057–1063
77. Glassy MC (1987) Immortalization of human lymphocytes from a tumor-involved lymph node. *Cancer Res* 47:5181–5188
78. Victoria GD, Nussenzweig MC (2012) Germinal centers. *Ann Rev Immunol* 30:429–457
79. Koda K, Nakajima N, Saito N, Yasutomi J, McKnight ME, Glassy MC (1998) A human natural antibody to adenocarcinoma that inhibits tumour cell migration. *Br J Cancer* 78:1313–1322
80. Kotlan B, Stroncek DF, Marincola FM (2009) Intravenous immunoglobulin-based immunotherapy: an arsenal of possibilities for patients and survival. *Immunotherapy* 1:995–1015
81. Giritch A, Marillonnet S, Engler C, van Eldik G, Botterman J, Klimyuk V et al (2006) Rapid high-yield expression of full-size IgG antibodies in plants coinfecting with noncompeting viral vectors. *Proc Natl Acad Sci USA* 103:14701–14706
82. Graumann K, Premstaller A (2006) Manufacturing of recombinant therapeutic proteins in microbial systems. *Biotechnol J* 1:164–186
83. Borrebaeck C, Carlsson R (2001) Human therapeutic antibodies. *Curr Opin Pharmacol* 1:404–408
84. Chames P, Regenmortel MV, Weiss E, Baty D (2009) Therapeutic antibodies: successes, limitations and hopes for the future. *Br J Pharmacol* 157:220–233
85. Cartron G, Dacheux L, Salles G, Solal-Celigny P, Bardos P, Colombat P et al (2002) Therapeutic activity of humanized anti-CD20 monoclonal antibody and polymorphism in IgG Fc receptor FcγRIIIa gene. *Blood* 99:754–758
86. Weng WK, Levy R (2003) Two immunoglobulin G fragment C receptor polymorphisms independently predict response to rituximab in patients with follicular lymphoma. *J Clin Oncol* 21:3940–3947
87. Shinkawa T, Nakamura K, Yamane N, Shoji-Hosaka E, Kanda Y, Sakurada M et al (2003) The absence of fucose but not the presence of galactose or bisecting N-acetylglucosamine of human IgG1 complex-type oligosaccharides shows the critical role of enhancing antibody-dependent cellular cytotoxicity. *J Biol Chem* 278:3466–3473
88. Siberil S, Dutertre CA, Boix C, Bonnin E, Menez R, Stura E et al (2006) Molecular aspects of human FcγRIII interactions with IgG: functional and therapeutic consequences. *Immunol Lett* 106:111–118

89. Cox KM, Sterling JD, Regan JT, Gasdaska JR, Frantz KK, Peele CG et al (2006) Glycan optimization of a human monoclonal antibody in the aquatic plant *Lemna minor*. *Nat Biotechnol* 24:1591–1597
90. Li H, Sethuraman N, Stadheim TA, Zha D, Prinz B, Ballew N et al (2006) Optimization of humanized IgGs in glycoengineered *Pichia pastoris*. *Nat Biotechnol* 24:210–215
91. Nechansky A, Schuster M, Jost W, Siegl P, Wiederkum S, Gorr G et al (2007) Compensation of endogenous IgG mediated inhibition of antibody-dependent cellular cytotoxicity by glyco-engineering of therapeutic antibodies. *Mol Immunol* 44:1815–1817
92. Prime W, Sobel ME, Herrington CS (2002) Utilization of human tissue in breast cancer research. *Breast Cancer Res* 2:237–240
93. van Diest PJ (2002) No consent should be needed for using leftover body material for scientific purposes: For and Against. *Br Med J* 325:648–651
94. Evans HM (2002) What's wrong with "retained organs"? Some personal reflections in the afterglow of "Alder Hey". *J Clin Pathol* 54:824–826
95. Malone T, Catalano PJ, O'Dwyer PJ, Giantonio B (2002) High rate of consent to bank biologic samples for future research: the Eastern cooperative oncology group experience. *J Natl Cancer Inst* 94:769–771
96. Schilsky RL, Dressler LM, Bucci D, Monovich L, Jewell S, Suster S et al (2002) Cooperative Group tissue banks as research resources: the Cancer and Leukemia Group B tissue repositories. *Clin Cancer Res* 8:943–948
97. Marshall E (2001) Families sue hospital, scientist for control of canavan gene: who controls and who benefits from human genetics research? *Monash Bioeth Rev* 20:50

Therapeutic Human Monoclonal Antibodies in Inflammatory Diseases

Sotirios Kotsovilis and Evangelos Andreakos

Abstract

Monoclonal antibodies (mAbs) are antibodies of a single antigen specificity produced by identical immune cells, i.e., clones of a common germ cell. They offer unprecedented opportunities to drug development because of their ability to target almost any cell surface or secreted molecule with remarkable efficacy and safety. In this chapter, the application of human mAbs in the treatment of inflammatory diseases is reviewed. We discuss in detail several mAb-based drugs such as anti-tumor necrosis factor (anti-TNF), anti-interleukin-1 (anti-IL-1) receptor, anti-IL-6 receptor, anti- α 4 integrin subunit, and anti-CD20 agents, all of which have been documented by clinical trials to be efficacious and have been approved for the therapy of several inflammatory and immune diseases, including rheumatoid arthritis, Crohn's disease, ulcerative colitis, spondyloarthropathies, juvenile arthritis, psoriasis, psoriatic arthritis, and others. These novel drugs can be used either as a monotherapy or in combination with other conventional therapeutic modalities, particularly if the disease under treatment is refractory to therapy using solely conventional techniques. As a large variety of mAb-based agents targeting a plethora of cytokines, chemokines, adhesion and co-stimulatory molecules, receptors, as well as diverse cell types, are presently under investigation, the therapeutic armamentarium of the clinician is expected to greatly broaden in the near future, providing improved patient care for a wide range of devastating diseases of our times.

Key words Chimeric monoclonal antibodies, Crohn's disease, Fully human monoclonal antibodies, Humanized monoclonal antibodies, Hybridoma, Monoclonal antibodies, Psoriasis, Psoriatic arthritis, Recombinant monoclonal antibodies, Rheumatoid arthritis

1 Introduction

Monoclonal antibodies (mAbs) can be defined as antibodies that all have affinity for the same antigen and are produced by identical immune cells, clones of a common germ cell. Since the 1970s, the methodologies available for generating mAbs have dramatically evolved from the hybridoma technology used to produce murine mAbs [1] to sophisticated recombinant engineering technologies [2, 3] appropriate to design specific mAbs of choice, thus producing humanized, chimeric, and completely (fully) human mAbs [4–8].

These novel methods have had major consequences in the development of clinically applicable mAbs against disease targets. The immunogenicity and safety of mAbs, a substantial limitation of antibodies produced by the hybridoma technology, could be overcome, and mAbs against any antigen specificity and with desirable physicochemical properties could be developed. High-scale production of mAbs at the industrial level could further be achieved. This has sparked a race for the development of antibody-mediated therapeutics in the clinic with the investment of large amounts of money from the biopharmaceutical sector towards that end which is already paying off. The major success of human mAbs in immune and inflammatory conditions, such as rheumatoid arthritis (RA), Crohn's disease, ulcerative colitis, spondyloarthropathies, juvenile arthritis, psoriasis, psoriatic arthritis, and others [9], marks merely the beginning of a rapidly evolving field with more than 150 diverse mAbs currently being evaluated in clinical trials or being candidates for approval by the Food and Drug Administration (FDA) in the USA. These developments will be discussed in the subsequent sections.

1.1 The Use of Monoclonal Antibodies in the Therapy of Rheumatoid Arthritis

The use of mAbs in the therapy of RA represents one of the earliest and at present most frequent and perhaps most successful therapeutic applications of mAbs [9]. In 1989, a study in rheumatoid synovial membrane cultures revealed that the use of anti-tumor necrosis factor (anti-TNF) mAbs could inhibit the local production of proinflammatory mediators, such as interleukins (ILs) -1, -6, -8 and granulocyte macrophage-colony stimulating factor [10]. Similar findings were shortly afterwards reported in vivo, as TNF-overexpressing transgenic mice developed inflammatory arthritis [11], while anti-TNF treatment of murine collagen-induced arthritis, that presents major analogies with RA in humans, led to amelioration of the disease [12]. Collectively, these in vitro and in vivo studies provided the proof-of-principle required for the initiation of clinical trials on the use of anti-TNF mAbs in the treatment of RA [13, 14].

The first results of the use of an anti-TNF agent were reported in an open Phase I/II clinical trial published in 1993, in which patients with persistent RA—refractory to previous treatment with disease-modifying drugs—were treated with infliximab (Remicade®, Centocor Biotech, Inc., presently Janssen Biotech, Inc., Horsham, Pennsylvania, USA; Table 1), a mouse–human chimeric anti-TNF antibody [15]. The mechanism of action of infliximab in RA is the abolishment of the activity of TNF through binding to the soluble or transmembrane form of TNF or the inhibition of the binding of the receptor-bound form of TNF to its cell receptors; infliximab can also induce apoptosis of T lymphocytes activated by TNF, at least in Crohn's disease [16]. Hence, in the aforementioned study [15], treatment with infliximab resulted in a remarkable improvement in clinical parameters—reduction in joint swelling and

Table 1

Main human mAb-based drugs or other types of immunosuppressive drugs used in the treatment of inflammatory diseases and pertinent main information

Drug generic name	Drug commercial name and company	Drug type, source, and target/mechanism	Administration route	Main side effects and complications	Legal status and approval
Abatacept	Orencia®, Bristol-Myers Squibb Company, New York City, New York, US	Dimeric fusion protein: Extracellular domain of CTLA-4 and Fc region of human IgG1 (inhibits the costimulation of T cells)	Injected intravenously	Respiratory side effects (upper respiratory tract infection, nasopharyngitis, sinusitis, bronchitis, etc.), hypersensitivity reactions, malignancies (e.g., lymphomas, lung cancer), gastrointestinal (e.g., nausea, diarrhea), urinary tract infection, rash, headache, local injection reactions	US: Rx-only drug ^a ; UK: POM ^b US: FDA-approved drug to treat RA, in cases of inadequate response to one or more DMARDs
Adalimumab	Humira®, Abbott Laboratories, North Chicago, Illinois, US	Fully human anti-TNF mAb-based drug	Injected subcutaneously	Serious and sometimes fatal side effects; however, side effects are scarce FDA Black Box Warning instructing monitoring of potential patients more carefully Reduced host resistance to new or reactivated latent infections (TB, histoplasmosis, etc.); rare reports of lymphoma, solid-tissue cancers, cardiac failure, serious liver injury, haematologic or demyelinating central nervous system disorders	US: Rx-only drug ^a ; UK: POM ^b FDA-approved drug to treat RA, Crohn's disease, moderate to severe chronic plaque psoriasis, psoriatic arthritis, ankylosing spondylitis, and juvenile idiopathic arthritis
Anakinra	Kineret®, Swedish Orphan Biotrum AB, Stockholm, Sweden	Human recombinant non-glycosylated form of IL-1RA (not mAb); anti-IL-1 activity (belongs to biological response modifiers)	Injected subcutaneously	Very frequently (in 70 % of patients), irritation of the injection site (pain, inflammation, or erythema); frequently, skin ecchymoses; risk of serious infection, e.g., respiratory infection (due to suppression of the immune system, e.g., decrease in neutrophil counts)	US: Rx-only drug ^a ; FDA-approved drug to treat RA in cases when previous treatment with one or more DMARDs failed; anakinra can be used alone or in combination with DMARDs other than anti-TNF drugs (etanercept, infliximab, etc.)

(continued)

Table 1
(continued)

Drug generic name	Drug commercial name and company	Drug type, source, and target/mechanism	Administration route	Main side effects and complications	Legal status and approval
Certolizumab pegol/ CDP870	Cimzia [®] , UCB Pharma SA, Brussels, Belgium	PEGylated ^c Fab fragment of a humanized (from mouse) anti-TNF mAb-based drug	Injected subcutaneously	Serious and sometimes fatal side effects, usually when other immunosuppressive drugs (corticosteroids, methotrexate) are also used; however, side effects are scarce Reduced host resistance to new or reactivated latent infections (TB, histoplasmosis, etc.); patients should receive a TB skin test before using Certolizumab; TB-positive patients should commence TB treatment before using Certolizumab; all patients (even TB-negative) should be monitored for TB while receiving Certolizumab Cancer (e.g., lymphoma) has been reported in children and teenagers	US: Rx-only drug ^a ; FDA-approved drug to treat Crohn's disease Europe: CHMP (of EMEA)-approved drug to treat only RA (not Crohn's disease) Not approved for use in children or teenagers
Etanercept	Enbrel [®] ; North America: Enbrel [®] is co-marketed by Amgen (that acquired Immunex), Thousand Oaks, California, US and Pfizer, Inc., New York City, New York, US; Japan: Enbrel [®] is marketed by Takeda Pharmaceutical Company Limited, Chuo-ku, Osaka, Japan	Chimeric anti-TNF dimeric fusion protein: soluble human 75 kDa TNFR2 and Fc region of human IgG1	Injected subcutaneously	Serious and sometimes fatal side effects; however, side effects are scarce FDA Black Box Warning instructing monitoring of potential patients more carefully Tuberculosis, bacterial sepsis, and life-threatening infections Patients should be educated about the symptoms of infection and closely monitored for signs and symptoms of infection during and after treatment with the drug	US: Rx-only drug ^a ; UK: POM ^b US: FDA-approved drug to treat moderate to severe RA, moderate to severe polyarticular juvenile idiopathic arthritis, psoriatic arthritis, ankylosing spondylitis, and moderate to severe plaque psoriasis

Golimumab	<p>Simpini[®], US and Canada: formerly Centocor Biotech, Inc., currently Janssen Biotech, Inc., Horsham, Pennsylvania, US (presently wholly owned subsidiary of Johnson & Johnson, New Brunswick, New Jersey, US); Europe: Merck & Co., Inc., Whitehouse Station, New Jersey, US</p>	Fully human anti-TNF mAb-based drug	Injected subcutaneously	<p>Serious and sometimes fatal side effects; however, side effects are scarce</p> <p>FDA Black Box Warning instructing monitoring of potential patients more carefully</p> <p>Reduced host resistance to new or reactivated latent infections (TB, hepatitis B, histoplasmosis, aspergillosis, candidiasis, etc.); cancer (e.g., lymphoma); congestive cardiac failure; acute liver failure; hematologic and nervous system disorders; allergic reactions (e.g., erythema of the injection site); respiratory side effects (upper respiratory tract infection, nasopharyngitis, bronchitis, sinusitis, etc.); lupus-like syndrome</p>	<p>US: Rx-only drug^a; FDA-approved drug to treat adults with active moderate to severe RA, psoriatic arthritis and ankylosing spondylitis</p>
Infliximab	<p>Remicade[®], formerly Centocor Biotech, Inc., currently Janssen Biotech, Inc., Horsham, Pennsylvania, US (presently wholly owned subsidiary of Johnson & Johnson, New Brunswick, New Jersey, US)</p>	Chimeric (mouse-human) anti-TNF mAb-based drug	Injected intravenously	<p>Serious and sometimes fatal side effects; however, side effects are scarce</p> <p>FDA Black Box Warning instructing monitoring of potential patients more carefully</p> <p>Reduced host resistance to new or reactivated latent infections (TB, hepatitis B, histoplasmosis, haematologic infections, pneumonia, etc.); cancer (e.g., lymphoma); cardiac failure; liver injury; haematologic and nervous system disorders; allergic reactions; psoriasis; lupus-like syndrome</p>	<p>US: Rx-only drug^a; FDA-approved drug to treat RA, Crohn's disease, psoriasis, psoriatic arthritis, ankylosing spondylitis, and ulcerative colitis</p>

(continued)

Table 1
(continued)

Drug generic name	Drug commercial name and company	Drug type, source, and target/mechanism	Administration route	Main side effects and complications	Legal status and approval
Natalizumab	Tysabri [®] , Biogen Idec, Weston, MA, US and Élan Corporation plc, Dublin, Ireland	Humanized (from mouse) anti- α 4 integrin mAb-based drug	Administered by intravenous infusions	<p>Serious and sometimes fatal side effects; however, side effects are scarce</p> <p>FDA Black Box Warning: Natalizumab is contraindicated in combination with other immunomodulators</p> <p>PML (31 FDA-confirmed cases of PML, almost exclusively observed when natalizumab was combined with other immunomodulating drugs)</p> <p>Allergic reactions, fatigue, headache, nausea, colds, exacerbation of Crohn's disease, liver injury</p>	<p>US: Rx-only drug³; FDA-approved drug to treat multiple sclerosis and for both induction of remission and maintenance of remission for moderate to severe Crohn's disease</p> <p>Natalizumab is the only drug after aleoetron withdrawn from the US market for safety reasons (3 PML cases in 2005) that returned to the US market after second FDA approval (in 2006) for the first- or second-line treatment of all relapsing forms of multiple sclerosis; patients receiving natalizumab should enter into a registry and be monitored</p> <p>EU: EMEA-approved drug to treat highly active relapsing remitting multiple sclerosis only as a monotherapy, but not Crohn's disease (concerns about cost-to-benefit ratio are under review)</p>

Rituximab	Rituxan® or MabThera®, US: Biogen Idec, Inc., Weston, Massachusetts, US and Genentech Inc., South San Francisco, California, US (currently wholly owned subsidiary of Hoffmann-La Roche Ltd.); Canada and EU: Hoffmann-LaRoche Ltd., Basel, Switzerland; Japan: Chugai Pharmaceutical Co., Ltd., Tokyo, Japan (52 %-owned by Hoffmann-La Roche Ltd.)	Chimeric (mouse-human) anti-human B-cell surface antigen CD20 mAb-based drug	Administered by intravenous infusions	Serious and sometimes fatal side effects, such as severe infusion reaction, cardiac arrest, cytokine release syndrome, tumor lysis syndrome, infections (e.g., reactivation of hepatitis B, progressive multifocal leukoencephalopathy, etc.), pulmonary toxicity However, side effects are very scarce	US: Rx-only drug ^a ; FDA- approved drug in combination with methotrexate to treat active moderate to severe RA (in Europe: only active severe RA) in adults with inadequate response to one or more anti-TNF drugs
Tocilizumab or atlizumab	Actemra® or RoActemra®, Hoffmann-La Roche Ltd., Basel, Switzerland and Chugai Pharmaceutical Co., Ltd., Tokyo, Japan (52 %-owned by Hoffmann-La Roche Ltd.)	Humanized (from mouse) anti-IL-6R mAb-based drug	Administered by intravenous infusions	Upper respiratory tract infections, nasopharyngitis, headache, high blood pressure	US: Rx-only drug ^a ; FDA- approved drug as Actemra® to treat RA and systemic juvenile idiopathic arthritis in children ≥2 years Japan: Additionally approved to treat Castleman's disease

CHMP Committee for Medicinal Products for Human Use, *CTLA-4* Cytotoxic T-lymphocyte antigen-4, *DMARDs* Disease-modifying antirheumatic drugs, *EMEA* European Medicines Agency, *EU* European Union, *Fab* Fragment antigen-binding portion of an antibody, *Fe* Fragment crystallizable (antibody constant region), *FDA* Food and Drug Administration, *IgG1* Immunoglobulin G1, *IL-1* Interleukin-1, *IL-1RA* Interleukin-1 receptor antagonist, *IL-6R* Interleukin-6 receptor, *mAb* Monoclonal antibody, *PEG* Polyethylene glycol, *PML* Progressive multifocal leukoencephalopathy, *POM* Prescription-only medicine, *RA* Rheumatoid arthritis, *TB* Tuberculosis, *TNF* Tumor necrosis factor, *TNFR2* Tumor necrosis factor receptor 2, *UK* United Kingdom, *US* United States

^aTerm used in the USA for drugs requiring a medical prescription in order to be sold by a pharmacist

^bTerm used in the UK for drugs requiring a medical prescription in order to be sold by a pharmacist

^cPEGylation is defined as the procedure of covalent attachment of PEG polymer chains to a molecule, typically a therapeutic protein or a drug

symptoms, such as pain—as well as biochemical parameters—reduction in the systemic levels of inflammatory mediators, such as C-reactive protein (CRP). The repetition of treatment with infliximab provided additional improvements [17]. These beneficial outcomes were confirmed in a Phase II multi-center double-masked randomized placebo-controlled clinical trial, reaching a reduction of up to 70 % in outcome measures [18]. Phase II and III clinical trials further revealed a sustained efficacy of repeated doses of infliximab (3 or 10 mg/kg every 4 or 8 weeks), combined with methotrexate, an antifolate drug suppressing the immune system [19, 20]. The combination of infliximab with methotrexate is now required by FDA labeling in RA and could be beneficial in other diseases as well, because it attenuates the generation of antibodies against infliximab and increases the duration of its efficacy [19]. Remarkably, in the Phase III clinical trial, at 2 years post-treatment cartilage and bone joint destruction was also halted and repair of cartilage and bone tissue occurred in more than half of the patient population.

In addition to infliximab, several other anti-TNF agents demonstrating similar efficacy have been approved for clinical use in the treatment of RA in the USA and Europe [21–25]. These anti-TNF agents are either mAbs or dimeric proteins produced by the fusion of TNF receptor 2 (TNFR2) with an antibody constant region (Fc region). Like anti-TNF mAbs, TNFR-Fc dimeric fusion proteins can also bind to TNF and inhibit its biological activities. Anti-TNF mAbs commercially available may be humanized—such as the humanized murine CDR3; CDP571 (Celltech Group plc, Slough, UK) [21]—or completely human antibodies—such as adalimumab (Humira®, Abbott Laboratories, North Chicago, Illinois, USA), originally discovered as D2E7 (Cambridge Antibody Technology Group Plc, Cambridgeshire, UK/BASF Bioresearch Corporation, Worcester, Massachusetts) [25] or PEG Fab, PEGylated CDP870 anti-TNF antibody (Celltech Group plc, Slough, UK/Pharmacia, Stockholm, Sweden; Table 1) [26]. TNFR-Fc dimeric fusion proteins include soluble human 75 kDa TNFR2-Fc region of human IgG1 fusion proteins—etanercept (Enbrel®; for manufacturers: Table 1) [23]—and soluble human 55 kDa TNFR2-Fc region of human IgG1 fusion proteins—lenercept (Roche Holding AG, Basel, Switzerland) (Table 1) [22]. Complications associated with the clinical use of these anti-TNF agents are rare and might include tuberculosis—particularly reactivation of latent tuberculosis—miliary and extrapulmonary diseases [9, 27]. These rare complications can be prevented by diagnosing active or inactive tuberculosis prior to the administration of anti-TNF agents and can be reversed by withdrawing treatment [9].

A recent systematic review evaluated the clinical effectiveness and cost-effectiveness of adalimumab, etanercept, infliximab, rituximab (Rituxan® or MabThera®, in the USA: Biogen Idec, Inc.,

Weston, Massachusetts, USA and Genentech Inc., South San Francisco, California, USA; in Canada and EU: Hoffmann-LaRoche Ltd., Basel, Switzerland and EU; and in Japan: Chugai Pharmaceutical Co., Ltd., Tokyo, Japan) and abatacept (Orencia[®], Bristol-Myers Squibb Company, New York City, New York, USA; Table 1) in patients presenting with RA refractory to previous treatment using conventional agents and an anti-TNF agent [28]. The selected randomized controlled trials revealed that rituximab and abatacept have a higher efficacy than supportive care [28]. The observational studies singled out demonstrated that the use of a second anti-TNF agent could possibly provide some clinical benefit, but this benefit might be modest and accompanied by a cost-effectiveness of questionable value [28]. Similar conclusions were also reported in a meta-analysis [29]. In a Cochrane systematic review, the efficacy and safety of certolizumab pegol (Table 1), a TNF inhibitor administered subcutaneously at doses ranging from 50 to 400 mg, were assessed [30]. At 24 and 52 weeks, certolizumab pegol provided significant benefits, compared with placebo or placebo plus methotrexate [30]. The most frequent adverse events associated with the use of certolizumab pegol occurred at a dose of 200 mg and included upper respiratory tract infections, hypertension, and nasopharyngitis [30]. A meta-analysis demonstrated that certolizumab pegol can be at least as efficacious as preceding antirheumatic anti-cytokine biological agents [31]. In another meta-analysis of randomized clinical trials of RA patients with inadequate response to methotrexate, TNF inhibitors were reported to be more likely to attain a 50 % improvement on the basis of the American College of Rheumatology criteria (ACR50 response) than abatacept [32]. In RA patients with inadequate response to TNF inhibitors, no significant difference was revealed among rituximab, tocilizumab, abatacept, and golimumab (Simponi[®], formerly Centocor Biotech, Inc., currently Janssen Biotech, Inc., Horsham, Pennsylvania, USA; Table 1) [32].

Apart from TNF, other proinflammatory mediators, such as IL-1, IL-1 receptor (IL-1R) [33–35], IL-6 [36, 37], or intercellular adhesion molecule-1 (ICAM-1) [38, 39], have also been targeted by neutralizing mAbs for the treatment of RA, many of which have resulted in significant improvements in disease parameters, as discussed below [40].

Anakinra (Kineret[®], Swedish Orphan Biovitrum AB, Stockholm, Sweden; Table 1), a human recombinant non-glycosylated form of IL-1 receptor antagonist (IL-1RA), produced using cultures of genetically modified *Escherichia coli* and recombinant DNA methods, has been developed for the treatment of RA. Anakinra is injected subcutaneously usually in single daily doses of 100 mg for a period of 24–60 weeks [41]. This drug is regarded as a biological response modifier that can inhibit IL-1 binding to IL-1R and therefore also abolish the activities of IL-1, such as the induction of inflammatory and immune responses, bone resorption

or cartilage degradation related to RA. It is worth mentioning that IL-1RA is also naturally present in RA patients, but the concentrations of natural IL-1RA in synovial fluid are too low to achieve the adequate inhibition of IL-1 activity in RA. Thus, anakinra can be used alone or in combination with disease-modifying antirheumatic drugs—but, remarkably, not with anti-TNF agents, as this combination increases the risk for infections—in the treatment of RA, particularly in cases refractory to treatment with disease-modifying antirheumatic drugs. Most usually, anakinra is used in combination with methotrexate.

Tocilizumab or atilizumab (Actemra® or RoActemra®, Hoffmann-La Roche Ltd., Basel, Switzerland and Chugai Pharmaceutical Co., Ltd., Tokyo, Japan) is a humanized anti-IL-6 receptor mAb-based immunosuppressive drug, currently approved in the USA for the treatment of cases of RA refractory to previous treatment with at least one anti-TNF agent (Table 1) [42]. Tocilizumab was produced in 1997 and subsequently implemented in the treatment of RA, systemic juvenile idiopathic arthritis (severe RA form in children), and Castleman's disease (rare benign B cell-tumor). IL-6 is involved in inflammatory and immune responses, such as those implicated in the initiation or progression of autoimmune diseases; RA is related to pathologically elevated levels of IL-6. Tocilizumab is administered intravenously on a monthly basis.

A systematic review concluded that the efficacy and safety of tocilizumab are promising on a short-term basis, but more long-term data may be needed to determine the risk-to-benefit ratio of the administration of this drug [42]. Another systematic review reported that the risk of diverticular perforation may be slightly higher in tocilizumab-treated RA patients, compared with those treated with conventional disease-modifying antirheumatic drugs or anti-TNF agents, but lower than that in corticosteroid-treated RA patients; hence, tocilizumab was overall shown to be safe [43]. Finally, a Cochrane systematic review reached the conclusion that the combination of tocilizumab with methotrexate/disease-modifying antirheumatic drugs is able to reduce the RA disease activity, but may result in a significant elevation in the levels of cholesterol [44]. Adverse events may arise, although they do not seem to be serious [44]. Tocilizumab combined with methotrexate to treat RA entailed a low risk of adverse events, comparable with that of other biological agents used in the therapy of RA [45]. Tocilizumab can be used alone in patients not tolerating methotrexate or disease-modifying antirheumatic drugs, or as an adjunct to these drugs, if they are not efficacious as a monotherapy.

Rituximab is an anti-human B-cell surface antigen CD20 chimeric mouse-human mAb (Table 1). As CD20 is an antigen located on B-cell surface (but not on terminally differentiated plasma cells), and rituximab is able to downregulate the B-cell receptor and induce CD20-positive B-cell apoptosis [46], rituximab

can be employed in the treatment of diseases affecting B cells, such as autoimmune diseases or neoplastic disorders (leukemias, lymphomas, etc.) [47, 48]. Rituximab is efficacious mainly in seropositive RA and novel radiographic data have confirmed beneficial effects of rituximab in early RA [49]. Rituximab has been approved in the USA and Europe for clinical application in combination with methotrexate in the therapy of moderate to severe active RA, which is refractory to anti-TNF treatment [50]. The most appropriate strategy of regimen and dosage is not entirely clear at present [49]. There is a need for screening for hepatitis and identifying patients potentially at higher infection risk by examining pre-therapeutic immunoglobulin levels, as well as a need for vaccination [49]. Adverse events associated with the use of rituximab are very scarce [49]. Detailed guidelines about the use of rituximab in RA treatment have recently been published by the British Society for Rheumatology and the British Health Professionals in Rheumatology [51], as well as the Rituximab Consensus Expert Committee [49]. Apart from rituximab, other anti-CD20 immunosuppressive mAb-based drugs have been produced, such as ocrelizumab (humanized anti-CD20 mAb-based drug; under development by Biogen Idec, Inc., Weston, Massachusetts, USA and Genentech Inc., South San Francisco, California, USA, the latter presently completely owned by Hoffmann-LaRoche Ltd., Basel, Switzerland), ofatumumab (completely human anti-CD20 mAb-based drug; Arzerra[®], Genmab A/S, Copenhagen, Denmark) and third-generation anti-CD20 mAb-based drugs. The latter drugs exhibit modifications in the Fc fragment or in the variable regions, aimed at enhancing antibody-dependent cellular cytotoxicity or apoptosis, respectively [52].

It is worth noting that mAb treatment against several promising targets for the treatment of RA have also failed. Thus, the application of both depleting and non-depleting mAbs against T lymphocytes has been evaluated extensively, but their efficacy was limited or variable [53–56]. The only promising agent has been the humanized non-depleting anti-CD4 antibody 4162 W94, that reduced RA and systemic CRP levels [57]. Keliximab, a chimeric mAb from *Macaca irus* and *Homo sapiens*, which can bind to leukocytes via CD4 protein and consequently attenuate the immune response, provided statistically significant clinical benefits in the therapy of RA [58].

1.2 The Use of Monoclonal Antibodies in the Therapy of Crohn's Disease and Ulcerative Colitis

Following the successful application of anti-TNF-based drugs in the treatment of RA in early studies, clinical trials were specifically designed to further assess the efficacy of this category of drugs in the therapy of Crohn's disease [9]. Crohn's disease is a bowel inflammatory disease, characterized—like RA—by an upregulation in TNF systemic levels [9].

In a short-term Phase I/II clinical trial, a single infliximab administration in patients presenting with Crohn's disease resistant to steroid therapy provided clinical and endoscopic beneficial outcomes in 70 % and 41 % of infliximab-treated patients after 4 and 12 weeks, respectively, whereas only 17 % and 12 % of placebo-treated patients, respectively, exhibited such improvements at the previously mentioned time-points [59]. Subsequent analyses of the same clinical trial data also revealed a reduction in endoscopic activity of Crohn's disease and in mucosal inflammation [60, 61]. Multiple administrations of infliximab at regular intervals of 8 weeks resulted in the maintenance of therapeutic outcome that had been attained with the initial infliximab infusion and therefore prevented the recurrence of Crohn's disease [62–64]. In a Phase II clinical trial, the use of infliximab resulted in fistula closure between the skin and the bowel in up to 68 % of patients [62]. In a Phase III clinical trial with a large sample size (296 patients), infliximab was efficacious in maintaining fistula closure after a year in 36 % of patients, compared to 19 % of subjects in the placebo control group [65]. In a multi-center trial investigating the efficacy of infliximab in the treatment of the inflammatory form of Crohn's disease, up to 45 % of infliximab-treated patients maintained clinical improvements after 30 weeks, compared with 21 % of placebo-treated subjects in the control group; overall, maintenance was achieved from 38 to 54 weeks, compared with 21 weeks in the control group [64]. Maintenance phase using infliximab is preferable to intermittent or sporadic therapy, because the probability of developing antibodies to infliximab—that limit its efficacy—is decreased. Infliximab has been proposed as the appropriate drug for remission during periods of Crohn's disease bursts, interposed between periods of disease quiescence [66]. Following the conduction of all aforementioned trials, infliximab was FDA-approved in the USA for the therapy both of the penetrating/fistulizing and the inflammatory form of Crohn's disease. In addition, infliximab has been approved for other indications, such as the treatment of ankylosing spondylitis, psoriasis, psoriatic arthritis, and ulcerative colitis. It should be noted, however, that FDA issued a warning that the use of infliximab is related to an increased risk for lymphoma and other malignancies; therefore, some concerns have been raised regarding the safety of infliximab in the long term.

Other anti-TNF agents, such as etanercept (Table 1) [67, 68] or the humanized anti-TNF mAbs CDP571 (Celltech, Chiroscience, Slough, UK) [69] and certolizumab pegol/CDP870 (Cimzia®, UCB Pharma SA, Brussels, Belgium), have also been used in the therapy of Crohn's disease. Etanercept appears to be less efficacious in the treatment of Crohn's disease than infliximab [70], possibly due to the inability of etanercept to bind to lesional activated T lymphocytes that express TNF and induce their apoptosis [16]. This mechanism has been suggested to be used by infliximab in efficaciously treating Crohn's disease [16].

Although additional studies will be required to draw definite conclusions, etanercept is not approved at present for the treatment of Crohn's disease [70]. Similarly, clinical trials have suggested that CDP571, the genetically engineered human TNF mAb, may also be effective in reducing Crohn's disease activity index at 2 weeks after an infusion [71]. Yet, CDP571 has not been approved for this indication, as more extensive studies are needed. In contrast, certolizumab pegol/CDP870 is an anti-TNF agent that has been approved by the FDA for the treatment of Crohn's disease in the USA, but not yet by the European Medicines Agency (EMA) in Europe (Table 1).

At least 30 systematic reviews currently exist on the efficacy of mAb-based drugs in the treatment of Crohn's disease. The main conclusions of the most recent systematic reviews will be briefly reviewed.

In a meta-analysis evaluating the efficacy and safety of the combination of infliximab and immunosuppressive drugs versus monotherapy for maintaining steroid-free clinical remission in Crohn's disease patients, the combination of infliximab and immunosuppressive drugs was found to be more efficacious than the monotherapy for the induction of remission at weeks 10–12 and for the maintenance of remission at weeks 24–26 [72]. The combination of infliximab and immunosuppressive drugs generally entailed a low risk of adverse events, comparable with that of monotherapy [72].

In a meta-analysis evaluating the efficacy and safety of adalimumab (Table 1) in the therapy of Crohn's disease, the use of adalimumab resulted in significantly higher rates of inducing and maintaining remission in Crohn's disease patients, compared with placebo [73]. No significant difference in total adverse events could be demonstrated on a short-term basis, but adalimumab was associated with significantly less serious adverse events than placebo on a long-term basis [73]. Accordingly, adalimumab was both efficacious and safe in the therapy of Crohn's disease [73]. In another meta-analysis, anti-TNF antibodies were more efficacious than placebo in inducing remission and preventing relapse of Crohn's disease [74].

According to another review, there are many important clinical trials on the use of infliximab in the treatment of Crohn's disease, revealing that this therapeutic modality can result in sustained steroid-free remission, rather than merely symptomatic relief [75]. Thus, infliximab is capable of inducing complete mucosal healing and reducing hospitalization and surgery rates [75]. In a systematic review, both adalimumab and infliximab were reported to be cost-effective in the therapy of active severe Crohn's disease, while adalimumab—but not infliximab—was found to be cost-effective for active moderate Crohn's disease, and none of these two anti-TNF agents possibly appeared to be cost-effective as maintenance for moderate or severe Crohn's disease [76]. In a systematic review, average remission time over 12 months was significantly higher for

adalimumab (39.9 %) than that for conventional non-biologic treatment modalities (6.6 %) [77]. Sensitivity analyses revealed that adalimumab was related to fewer expected hospitalizations, higher rates of fistula closure and lower rates of adverse events [77]. Overall, it appeared that adalimumab exhibited higher efficacy and safety, compared with conventional non-biologic treatment modalities for moderate to severe Crohn's disease refractory to non-biologic therapeutic approaches [77].

Natalizumab (Tysabri[®], Biogen Idec, Weston, MA, USA and Élan Corporation plc, Dublin, Ireland) is a humanized anti- α 4 integrin mAb [78], FDA-approved for the therapy of Crohn's disease, as well as multiple sclerosis (Table 1). In a meta-analysis, natalizumab was more efficacious in inducing remission of Crohn's disease, compared with placebo [74]. The mechanism of action of natalizumab appears to be based on its capacity to attenuate the attachment and migration of inflammatory cells through intestine and blood-brain barriers. Nonetheless, the clinical use of natalizumab has been associated with progressive multifocal leukoencephalopathy and therefore the drug is approved in the EU solely for the therapy of multiple sclerosis.

Like Crohn's disease, ulcerative colitis is an inflammatory disease of the gastrointestinal tract. In two large randomized double-masked placebo-controlled clinical trials, the Active Ulcerative Colitis Trials 1 and 2 (ACT1 and ACT2, respectively), the efficacy of infliximab in active therapy and maintenance was assessed in 364 adults with moderate to severe active ulcerative colitis [79]. Treatment with infliximab was performed for 46 or 22 weeks and participants were followed for 54 or 30 weeks in ACT1 or ACT2, respectively [79]. In ACT1, 69 % of patients who were treated with 5 mg infliximab and 61 % of those who were treated with 10 mg infliximab exhibited a clinical response (defined as a decrease of at least three points and at least 30 % in the Mayo score, accompanied by a decrease of at least one point or an absolute rectal-bleeding subscore of zero or 1 at 8 weeks), which was statistically significantly higher ($p < 0.001$ in both comparisons) than 37 % of subjects who received placebo [79]. Similar statistically significant differences in favor of infliximab-treated patients were demonstrated at 8 weeks in ACT2 ($p < 0.001$), at 30 weeks in both studies ($p \leq 0.002$) or at 54 weeks in ACT1 ($p < 0.001$). These findings suggested that the use of infliximab was clinically efficacious in the treatment of ulcerative colitis [79]. Finally, in a meta-analysis, infliximab was more efficacious than placebo in inducing remission of moderate to severe ulcerative colitis [74].

1.3 The Use of Monoclonal Antibodies in the Therapy of Spondyloarthropathies and Juvenile Arthritis

Ankylosing spondylitis is a chronic inflammatory disorder that affects the sacroiliac joints, the spine and, more rarely, the peripheral joints [80]. Conventional methods to treat ankylosing spondylitis include nonsteroidal anti-inflammatory drugs, sulphasalazine, pamidronate, and steroid injection into sacroiliac joints [80].

Anti-TNF biological agents can provide early improvements that could possibly be maintained over the long term [80]. It is generally recommended to initiate the treatment of ankylosing spondylitis patients with anti-TNF biological agents at the early disease stages, rather than at later time-points [80]. Several anti-TNF agents are now being used in the treatment of spondyloarthropathies, including infliximab, etanercept, adalimumab, and golimumab (Table 1). Infliximab has been shown to be effective in the treatment of spondyloarthropathy [81–83] or ankylosing spondylitis [84], although multiple administrations are needed in order to maintain the therapeutic outcome. Similarly, etanercept is efficacious in the therapy of spondyloarthropathies [85] or juvenile arthritis [86, 87].

In a systematic review, infliximab and etanercept were suggested to provide some benefit in the treatment of undifferentiated spondyloarthritis with respect to clinical outcomes, function, and quality of life as outcome measures [88]. Infliximab and adalimumab resulted in a substantial benefit, when used to treat axial spondyloarthritis, while no serious adverse events arose [88]. Infliximab is an FDA-approved drug for the treatment of ankylosing spondylitis, while adalimumab is FDA-approved for the treatment of ankylosing spondylitis and juvenile idiopathic arthritis, and etanercept is FDA-approved for the treatment of ankylosing spondylitis and moderate to severe polyarticular juvenile idiopathic arthritis (Table 1).

Tocilizumab, an anti-IL-6 receptor agent, can also be safely and efficaciously used in the treatment of systemic juvenile idiopathic arthritis [89], either alone or in combination with methotrexate, like in RA treatment, as described in a preceding paragraph. Tocilizumab is an FDA-approved drug for the treatment of RA and systemic juvenile idiopathic arthritis in children ≥ 2 years (Table 1).

1.4 The Use of Monoclonal Antibodies in the Therapy of Psoriasis and Psoriatic Arthritis

Both infliximab and etanercept have been shown to be efficacious in treating psoriasis [90, 91] and psoriatic arthritis, a systemic chronic inflammatory disorder characterized by the association of psoriasis and arthritis [92].

A systematic review demonstrated no evidence of an increased risk for serious infection or malignancy associated with the use of anti-TNF agents on a short-term basis in patients presenting with psoriasis [93]. Etanercept, infliximab and adalimumab have been approved in many countries for the therapy of moderate to severe chronic psoriasis and psoriatic arthritis, particularly in cases refractory to conventional treatment, such as nonsteroidal anti-inflammatory drugs [94]. Another systematic review evaluating the clinical effectiveness, safety and cost-effectiveness of the above-mentioned drugs in treating psoriatic arthritis revealed that all drugs provided significant improvements with respect to all joint

disease and functional status outcomes at 12–14 weeks post-treatment, as well as at 24 weeks at the maintenance phase [94]. On a short-term basis, all three agents could retard the progression of joint disease and there is sufficient evidence for their use in the therapy of psoriatic arthritis [94]. Infliximab appeared to be the most effective biological agent with respect to outcomes of joint and skin disease [94]. No statistically significant differences in responses in joint and skin diseases were revealed between etanercept and adalimumab [94]. Nevertheless, additional studies including larger sample sizes and long-term data are required to assess the maintenance of the therapeutic outcomes, as well as the safety of etanercept, infliximab and adalimumab [94].

Finally, a systematic analysis of the efficacy and safety of anti-TNF biological agents in the treatment of psoriatic arthritis revealed that adalimumab, etanercept and infliximab were significantly more efficacious in treating psoriatic arthritis, compared to placebo [95]. No statistically significant differences in the proportions of patient withdrawals due to any reason, withdrawals owing to adverse events, serious adverse events or infections of the upper respiratory tract were demonstrated between anti-TNF biological agents and placebo [95].

According to the recommendations of the French Society for Rheumatology, there are four main indications for the use of anti-TNF biological agents to treat ankylosing spondylitis or psoriatic arthritis [96]. First, presence of a definitive diagnosis of ankylosing spondylitis or psoriatic arthritis. Second, presence of active disease throughout a period of more than a month, concomitant presence of Bath Ankylosing Spondylitis Disease Activity Index (BASDAI) ≥ 4 in patients with mainly axial disease or a tender/swollen joint count = 3, and presence of an assessment of disease activity of $\geq 4/10$ by a physician. Third, inadequacy of at least three nonsteroidal anti-inflammatory drugs to treat axial disease or insufficiency of disease-modifying antirheumatic drug therapy (e.g., methotrexate) to treat peripheral disease. Fourth, absence of contraindications to treatment with anti-TNF agents.

Although anti-TNF biological agents are efficacious in the therapy of psoriasis, the use of anti-TNF agents has been related to a higher incidence of active tuberculosis [97]. According to a US National Psoriasis Foundation consensus statement, all patients should therefore be carefully monitored for latent tuberculosis before the initiation of any immune therapy and it is also recommended to postpone immune therapy until the completion of prophylaxis for latent tuberculosis; should the patient tolerate the prophylactic regimen uneventfully, therapy might be commenced after 1–2 months [97].

Apart from anti-TNF biological agents, other types of drugs, such as genetically engineered immunosuppressive fusion proteins, which act as neutralizing mAbs, were also successful in the treatment

of chronic plaque psoriasis [98]. Such fusion proteins were cytotoxic T-lymphocyte antigen-4-immunoglobulin G1 (CTLA-4-IgG1; genetically engineered soluble form of CTLA-4/CD152 that downregulates immune responses; for example, abatacept; Table 1) or alefacept (CD58/lymphocyte function-associated antigen-3-immunoglobulin G1 [LFA-3-IgG1] human fusion protein that binds to CD2 on memory effector T lymphocytes, therefore preventing their activation). It might be pointed out, however, that alefacept (formerly Amevive®, Astellas Pharma US, Inc., Deerfield, IL, USA) has not been available in the market since 2011, owing to supply disruption, according to the manufacturer. Moreover, until now abatacept has not been FDA-approved for the treatment of psoriasis and psoriatic arthritis.

1.5 The Use of Monoclonal Antibodies in the Therapy of Other Diseases and Conditions

Etanercept has been used against Wegener's granulomatosis [99], systemic sclerosis [100] and uveitis [101]. A humanized anti-IL-2 receptor α antibody, named anti-Tac (HAT), targeted against the activity of IL-2, has been reported to be safe and efficacious in the treatment of bilateral chronic noninfectious uveitis [102]. Similarly, neutralizing mAbs targeted against adhesion molecules and costimulatory inflammatory mediators, such as an anti- α 4 integrin subunit humanized mAb, can be efficacious in the therapy of multiple sclerosis [103]. For example, natalizumab is an FDA-approved drug of this category for the treatment of multiple sclerosis (Table 1).

2 Conclusions

On the basis of the present review of the literature, the following conclusions can be drawn:

- Throughout the past two decades, several mAb-based drugs, the most prominent of which are anti-TNF, anti-IL-1 receptor, anti-IL-6 receptor, anti- α 4 integrin subunit or anti-CD20 agents, have been documented by clinical trials to be efficacious and have been approved for the therapy of major inflammatory and immune diseases, such as rheumatoid arthritis, Crohn's disease, ulcerative colitis, spondyloarthropathies, juvenile arthritis, psoriasis, psoriatic arthritis and others.
- These agents can be used either as a monotherapy or in combination with other conventional therapeutic modalities, particularly if the disease under treatment is refractory to therapy using solely conventional techniques.
- In clinical practice, the selection of a therapeutic agent should be made not only on the basis of the efficacy of the agent as a criterion, but also by considering safety and economic parameters. Some drugs have been withdrawn from the market on account of safety concerns, whereas the clinical use of other agents is not considered to be cost-effective.

- A remarkable variety of agents targeting a plethora of cytokines, chemokines, adhesion and co-stimulatory molecules, receptors, as well as diverse cell types, are presently under investigation and it is estimated that the therapeutic armamentarium of the clinician will greatly broaden in the near future.

References

1. Köhler G, Milstein C (1975) Continuous cultures of fused cells secreting antibody of predefined specificity. *Nature* 256:495–497
2. Smith GP (1985) Filamentous fusion phage: novel expression vectors that display cloned antigens on the virion surface. *Science* 228:1315–1317
3. Siegel DL (2002) Recombinant monoclonal antibody technology. *Transfus Clin Biol* 9:15–22
4. Boulianne GL, Hozumi N, Shulman MJ (1984) Production of functional chimaeric mouse/human antibody. *Nature* 312:643–646
5. Morrison SL, Johnson MJ, Herzenberg LA, Oi VT (1984) Chimeric human antibody molecules: mouse antigen-binding domains with human constant region domains. *Proc Natl Acad Sci USA* 81:6851–6855
6. Neuberger MS, Williams GT, Mitchell EB, Jouhal SS, Flanagan JG, Rabbitts TH (1985) A hapten-specific chimaeric IgE antibody with human physiological effector function. *Nature* 314:268–270
7. McCafferty J, Griffiths AD, Winter G, Chiswell DJ (1990) Phage antibodies: filamentous phage displaying antibody variable domains. *Nature* 348:552–554
8. Lonberg N, Huszar D (1995) Human antibodies from transgenic mice. *Int Rev Immunol* 13:65–93
9. Andreakos E, Taylor PC, Feldmann M (2002) Monoclonal antibodies in immune and inflammatory diseases. *Curr Opin Biotechnol* 13:615–620
10. Brennan FM, Chantry D, Jackson A, Maini R, Feldmann M (1989) Inhibitory effect of TNF alpha antibodies on synovial cell interleukin-1 production in rheumatoid arthritis. *Lancet* 334:244–247
11. Keffer J, Probert L, Cazlaris H, Georgopoulos S, Kaslaris E, Kioussis D, Kollias G (1991) Transgenic mice expressing human tumour necrosis factor: a predictive genetic model of arthritis. *EMBO J* 10:4025–4031
12. Williams RO, Feldmann M, Maini RN (1992) Anti-tumor necrosis factor ameliorates joint disease in murine collagen-induced arthritis. *Proc Natl Acad Sci USA* 89:9784–9788
13. Feldmann M, Maini RN (2001) Anti-TNF alpha therapy of rheumatoid arthritis: what have we learned? *Annu Rev Immunol* 19:163–196
14. Feldmann M (2002) Development of anti-TNF therapy for rheumatoid arthritis. *Nat Rev Immunol* 2:364–371
15. Elliott MJ, Maini RN, Feldmann M et al (1993) Treatment of rheumatoid arthritis with chimeric monoclonal antibodies to tumor necrosis factor alpha. *Arthritis Rheum* 36:1681–1690
16. Van den Brande JM, Braat H, van den Brink GR et al (2003) Infliximab but not etanercept induces apoptosis in lamina propria T-lymphocytes from patients with Crohn's disease. *Gastroenterology* 124:1774–1785
17. Elliott MJ, Maini RN, Feldmann M, Long-Fox A, Charles P, Bijl H, Woody JN (1994) Repeated therapy with monoclonal antibody to tumour necrosis factor alpha (cA2) in patients with rheumatoid arthritis. *Lancet* 344:1125–1127
18. Elliott MJ, Maini RN, Feldmann M et al (1994) Randomised double-blind comparison of chimeric monoclonal antibody to tumour necrosis factor α (cA2) versus placebo in rheumatoid arthritis. *Lancet* 344:1105–1110
19. Maini R, St Clair EW, Breedveld F et al (1999) Infliximab (chimeric anti-tumour necrosis factor alpha monoclonal antibody) versus placebo in rheumatoid arthritis patients receiving concomitant methotrexate: a randomised phase III trial. ATTRACT Study Group. *Lancet* 354:1932–1939
20. Lipsky PE, van der Heijde DM, St Clair EW et al (2000) Infliximab and methotrexate in the treatment of rheumatoid arthritis. Anti-tumor necrosis factor trial in rheumatoid arthritis with concomitant therapy study group. *N Engl J Med* 343:1594–1602
21. Rankin EC, Choy EH, Kassimos D, Kingsley GH, Sopwith AM, Isenberg DA, Panayi GS (1995) The therapeutic effects of an engineered human anti-tumour necrosis factor alpha antibody (CDP571) in rheumatoid arthritis. *Br J Rheumatol* 34:334–342
22. Sander O, Rau R, van Riel P et al (1996) Neutralization of TNF by Lenercept

- (TNFR55-IgG1, Ro 45-2081) in patients with rheumatoid arthritis treated for three months: results of a European phase II trial. *Arthritis Rheum* 39:S242
23. Moreland LW, Baumgartner SW, Schiff MH et al (1997) Treatment of rheumatoid arthritis with a recombinant human tumor necrosis factor receptor (p75)-Fc fusion protein. *N Engl J Med* 337:141–147
 24. Weinblatt ME, Kremer JM, Bankhurst AD, Bulpitt KJ, Fleischmann RM, Fox RI, Jackson CG, Lange M, Burge DJ (1999) A trial of etanercept, a recombinant tumor necrosis factor receptor: Fc fusion protein, in patients with rheumatoid arthritis receiving methotrexate. *N Engl J Med* 340:253–259
 25. Barrera P, Joosten LA, den Broeder AA, van de Putte LB, van Riel PL, van den Berg WB (2001) Effects of treatment with a fully human anti-tumour necrosis factor alpha monoclonal antibody on the local and systemic homeostasis of interleukin 1 and TNFalpha in patients with rheumatoid arthritis. *Ann Rheum Dis* 60:660–669
 26. Choy EH, Hazleman B, Smith M, Moss K, Lisi L, Scott DG, Patel J, Sopwith M, Isenberg DA (2002) Efficacy of a novel PEGylated humanised anti-TNF fragment (CDP870) in patients with rheumatoid arthritis: a phase II double-blinded, randomized, dose-escalating trial. *Rheumatology (Oxford)* 41:1133–1137
 27. Keane J, Gershon S, Wise RP, Mirabile-Levens E, Kasznica J, Schwieterman WD, Siegel JN, Braun MM (2001) Tuberculosis associated with infliximab, a tumor necrosis factor alpha-neutralizing agent. *N Engl J Med* 345:1098–1104
 28. Malotki K, Barton P, Tsourapas A, Uthman AO, Liu Z, Routh K, Connock M, Jobanputra P, Moore D, Fry-Smith A, Chen YF (2011) Adalimumab, etanercept, infliximab, rituximab and abatacept for the treatment of rheumatoid arthritis after the failure of a tumour necrosis factor inhibitor: a systematic review and economic evaluation. *Health Technol Assess* 15:1–278
 29. Rémy A, Avouac J, Gossec L, Combe B (2011) Clinical relevance of switching to a second tumour necrosis factor-alpha inhibitor after discontinuation of a first tumour necrosis factor-alpha inhibitor in rheumatoid arthritis: a systematic literature review and meta-analysis. *Clin Exp Rheumatol* 29:96–103
 30. Ruiz Garcia V, Jobanputra P, Burls A, Cabello JB, Gálvez Muñoz JG, Saiz Cuenca ES, Fry-Smith A (2011) Certolizumab pegol (CDP870) for rheumatoid arthritis in adults. *Cochrane Database Syst Rev* CD007649
 31. Launois R, Avouac B, Berenbaum F, Blin O, Bru I, Fautrel B, Joubert JM, Sibilia J, Combe B (2011) Comparison of certolizumab pegol with other anticytokine agents for treatment of rheumatoid arthritis: a multiple-treatment Bayesian metaanalysis. *J Rheumatol* 38:835–845
 32. Salliot C, Finckh A, Katchamart W, Lu Y, Sun Y, Bombardier C, Keystone E (2011) Indirect comparisons of the efficacy of biological anti-rheumatic agents in rheumatoid arthritis in patients with an inadequate response to conventional disease-modifying antirheumatic drugs or to an anti-tumour necrosis factor agent: a meta-analysis. *Ann Rheum Dis* 70:266–271
 33. Drevlow BE, Lovis R, Haag MA, Sinacore JM, Jacobs C, Blosche C, Landay A, Moreland LW, Pope RM (1996) Recombinant human interleukin-1 receptor type I in the treatment of patients with active rheumatoid arthritis. *Arthritis Rheum* 39:257–265
 34. Jiang Y, Genant HK, Watt I, Cobby M, Bresnihan B, Aitchison R, McCabe D (2000) A multicenter, double-blind, dose-ranging, randomized, placebo-controlled study of recombinant human interleukin-1 receptor antagonist in patients with rheumatoid arthritis: radiologic progression and correlation of Genant and Larsen scores. *Arthritis Rheum* 43:1001–1009
 35. Cohen S, Hurd E, Cush J, Schiff M, Weinblatt ME, Moreland LW, Kremer J, Bear MB, Rich WJ, McCabe D (2002) Treatment of rheumatoid arthritis with anakinra, a recombinant human interleukin-1 receptor antagonist, in combination with methotrexate: results of a twenty-four-week, multicenter, randomized, double-blind, placebo-controlled trial. *Arthritis Rheum* 46:614–624
 36. Wendling D, Racadot E, Wijdenes J (1993) Treatment of severe rheumatoid arthritis by anti-interleukin 6 monoclonal antibody. *J Rheumatol* 20:259–262
 37. Yoshizaki K, Nishimoto N, Mihara M, Kishimoto T (1998) Therapy of rheumatoid arthritis by blocking IL-6 signal transduction with a humanized anti-IL-6 receptor antibody. *Springer Semin Immunopathol* 20:247–259
 38. Kavanaugh AF, Davis LS, Nichols LA, Norris SH, Rothlein R, Scharshmidt LA, Lipsky PE (1994) Treatment of refractory rheumatoid arthritis with a monoclonal antibody to intercellular adhesion molecule 1. *Arthritis Rheum* 37:992–999
 39. Kavanaugh AF, Davis LS, Jain RI, Nichols LA, Norris SH, Lipsky PE (1996) A phase I/II open label study of the safety and efficacy of

- an anti-ICAM-1 (intercellular adhesion molecule-1; CD54) monoclonal antibody in early rheumatoid arthritis. *J Rheumatol* 23:1338–1344
40. Kavanaugh AF, Schulze-Koops H, Davis LS, Lipsky PE (1997) Repeat treatment of rheumatoid arthritis patients with a murine anti-intercellular adhesion molecule 1 monoclonal antibody. *Arthritis Rheum* 40:849–853
 41. Fleischmann RM, Tesser J, Schiff MH, Schechtman J, Burmester GR, Bennett R, Modafferi D, Zhou L, Bell D, Appleton B (2006) Safety of extended treatment with anakinra in patients with rheumatoid arthritis. *Ann Rheum Dis* 65:1006–1012
 42. Navarro-Millán I, Singh JA, Curtis JR (2012) Systematic review of tocilizumab for rheumatoid arthritis: a new biologic agent targeting the interleukin-6 receptor. *Clin Ther* 34:788–802
 43. Gout T, Östör AJ, Nisar MK (2011) Lower gastrointestinal perforation in rheumatoid arthritis patients treated with conventional DMARDs or tocilizumab: a systematic literature review. *Clin Rheumatol* 30:1471–1474
 44. Singh JA, Beg S, Lopez-Olivo MA (2011) Tocilizumab for rheumatoid arthritis: a Cochrane systematic review. *J Rheumatol* 38:10–20
 45. Campbell L, Chen C, Bhagat SS, Parker RA, Östör AJ (2011) Risk of adverse events including serious infections in rheumatoid arthritis patients treated with tocilizumab: a systematic literature review and meta-analysis of randomized controlled trials. *Rheumatology (Oxford)* 50:552–562
 46. Shaw T, Quan J, Totoritis MC (2003) B cell therapy for rheumatoid arthritis: the rituximab (anti-CD20) experience. *Ann Rheum Dis* 62(suppl 2):ii55–ii59
 47. Maloney DG, Grillo-López AJ, White CA et al (1997) IDEC-C2B8 (Rituximab) anti-CD20 monoclonal antibody therapy in patients with relapsed low-grade non-Hodgkin's lymphoma. *Blood* 90:2188–2195
 48. Scott SD (1998) Rituximab: a new therapeutic monoclonal antibody for non-Hodgkin's lymphoma. *Cancer Pract* 6:195–197
 49. Buch MH, Smolen JS, Betteridge N et al (2011) Updated consensus statement on the use of rituximab in patients with rheumatoid arthritis. *Ann Rheum Dis* 70:909–920
 50. Tak PP, Kalden JR (2011) Advances in rheumatology: new targeted therapeutics. *Arthritis Res Ther* 13(Suppl 1):S5
 51. Bukhari M, Abernethy R, Deighton C et al (2011) BSR and BHPR guidelines on the use of rituximab in rheumatoid arthritis. *Rheumatology (Oxford)* 50:2311–2313
 52. Eccles SA (2001) Monoclonal antibodies targeting cancer: “magic bullets” or just the trigger? *Breast Cancer Res* 3:86–90
 53. Choy EH, Chikanza IC, Kingsley GH, Corrigan V, Panayi GS (1992) Treatment of rheumatoid arthritis with single dose or weekly pulses of chimaeric anti-CD4 monoclonal antibody. *Scand J Immunol* 36:291–298
 54. Kirkham BW, Thien F, Pelton BK, Pitzalis C, Amlot P, Denman AM, Panayi GS (1992) Chimeric CD7 monoclonal antibody therapy in rheumatoid arthritis. *J Rheumatol* 19:1348–1352
 55. Olsen NJ, Brooks RH, Cush JJ, Lipsky PE, St Clair EW, Matteson EL, Gold KN, Cannon GW, Jackson CG, McCune WJ, Fox DA, Nelson B, Lorenz T, Strand V (1996) A double-blind, placebo-controlled study of anti-CD5 immunoconjugate in patients with rheumatoid arthritis. The Xoma RA Investigator Group. *Arthritis Rheum* 39:1102–1108
 56. Isaacs JD, Manna VK, Rapson N, Bulpitt KJ, Hazleman BL, Matteson EL, St Clair EW, Schnitzer TJ, Johnston JM (1996) CAMPATH-1H in rheumatoid arthritis—an intravenous dose-ranging study. *Br J Rheumatol* 35:231–240
 57. Choy EH, Connolly DJ, Rapson N, Jeal S, Brown JC, Kingsley GH, Panayi GS, Johnston JM (2000) Pharmacokinetic, pharmacodynamic and clinical effects of a humanized IgG1 anti-CD4 monoclonal antibody in the peripheral blood and synovial fluid of rheumatoid arthritis patients. *Rheumatology (Oxford)* 39:1139–1146
 58. Veale DJ, Reece RJ, Parsons W, Radjenovic A, O'Connor PJ, Orgles CS, Berry E, Ridgway JP, Mason U, Boylston AW, Gibbon W, Emery P (1999) Intra-articular primatised anti-CD4: efficacy in resistant rheumatoid knees. A study of combined arthroscopy, magnetic resonance imaging, and histology. *Ann Rheum Dis* 58:342–349
 59. Targan SR, Hanauer SB, van Deventer SJ, Mayer L, Present DH, Braakman T, DeWoody KL, Schaible TF, Rutgeerts PJ (1997) A short-term study of chimeric monoclonal antibody cA2 to tumor necrosis factor alpha for Crohn's disease. Crohn's Disease cA2 Study Group. *N Engl J Med* 337:1029–1035
 60. Baert FJ, D'Haens GR, Peeters M, Hiele MI, Schaible TF, Shealy D, Geboes K, Rutgeerts PJ (1999) Tumor necrosis factor alpha antibody (infliximab) therapy profoundly down-regulates the inflammation in Crohn's ileocolitis. *Gastroenterology* 116:22–28

61. D'Haens G, Van Deventer S, Van Hogezaand R, Chalmers D, Kothe C, Baert F, Braakman T, Schaible T, Geboes K, Rutgeerts P (1999) Endoscopic and histological healing with infliximab anti-tumor necrosis factor antibodies in Crohn's disease: A European multicenter trial. *Gastroenterology* 116:1029–1034
62. Present DH, Rutgeerts P, Targan S, Hanauer SB, Mayer L, van Hogezaand RA, Podolsky DK, Sands BE, Braakman T, DeWoody KL, Schaible TF, van Deventer SJ (1999) Infliximab for the treatment of fistulas in patients with Crohn's disease. *N Engl J Med* 340:1398–1405
63. Rutgeerts P, D'Haens G, Targan S, Vasiliasukas E, Hanauer SB, Present DH, Mayer L, Van Hogezaand RA, Braakman T, DeWoody KL, Schaible TF, Van Deventer SJ (1999) Efficacy and safety of retreatment with anti-tumor necrosis factor antibody (infliximab) to maintain remission in Crohn's disease. *Gastroenterology* 117:761–769
64. Hanauer SB, Feagan BG, Lichtenstein GR, Mayer LF, Schreiber S, Colombel JF, Rachmilewitz D, Wolf DC, Olson A, Bao W, Rutgeerts P, ACCENT I Study Group (2002) Maintenance infliximab for Crohn's disease: the ACCENT I randomised trial. *Lancet* 359:1541–1549
65. Sands BE, Anderson FH, Bernstein CN, Chey WY, Feagan BG, Fedorak RN, Kamm MA, Korzenik JR, Lashner BA, Onken JE, Rachmilewitz D, Rutgeerts P, Wild G, Wolf DC, Marsters PA, Travers SB, Blank MA, van Deventer SJ (2004) Infliximab maintenance therapy for fistulizing Crohn's disease. *N Engl J Med* 350:876–885
66. Hanauer SB (2003) Crohn's disease: step up or top down therapy. *Best Pract Res Clin Gastroenterol* 17:131–137
67. D'Haens G, Swijsen C, Noman M, Lemmens L, Ceuppens J, Agbahiwe H, Geboes K, Rutgeerts P (2001) Etanercept in the treatment of active refractory Crohn's disease: a single-center pilot trial. *Am J Gastroenterol* 96:2564–2568
68. Sandborn WJ, Hanauer SB, Katz S, Safdi M, Wolf DG, Baerg RD, Tremaine WJ, Johnson T, Diehl NN, Zinsmeister AR (2001) Etanercept for active Crohn's disease: a randomized, double-blind, placebo-controlled trial. *Gastroenterology* 121:1088–1094
69. Sandborn WJ, Feagan BG, Hanauer SB, Present DH, Sutherland LR, Kamm MA, Wolf DC, Baker JP, Hawkey C, Archambault A, Bernstein CN, Novak C, Heath PK, Targan SR, CDP571 Crohn's Disease Study Group (2001) An engineered human antibody to TNF (CDP571) for active Crohn's disease: a randomized double-blind placebo-controlled trial. *Gastroenterology* 120:1330–1338
70. Kupper TS (2004) Etanercept for Crohn's disease. *N Engl J Med* 350:840
71. Akobeng AK, Zochos M (2004) Tumor necrosis factor-alpha antibody for induction of remission in Crohn's disease. *Cochrane Database Syst Rev* CD003574
72. Lin Z, Bai Y, Zheng P (2011) Meta-analysis: efficacy and safety of combination therapy of infliximab and immunosuppressives for Crohn's disease. *Eur J Gastroenterol Hepatol* 23:1100–1110
73. Huang ML, Ran ZH, Shen J, Li XB, Xu XT, Xiao SD (2011) Efficacy and safety of adalimumab in Crohn's disease: meta-analysis of placebo-controlled trials. *J Dig Dis* 12:165–172
74. Ford AC, Sandborn WJ, Khan KJ, Hanauer SB, Talley NJ, Moayyedi P (2011) Efficacy of biological therapies in inflammatory bowel disease: systematic review and meta-analysis. *Am J Gastroenterol* 106:644–659
75. Danese S, Colombel JF, Reinisch W, Rutgeerts PJ (2011) Review article: infliximab for Crohn's disease treatment—shifting therapeutic strategies after 10 years of clinical experience. *Aliment Pharmacol Ther* 33:857–869
76. Dretzke J, Edlin R, Round J, Connock M, Hulme C, Czczot J, Fry-Smith A, McCabe C, Meads C (2011) A systematic review and economic evaluation of the use of tumour necrosis factor-alpha (TNF- α) inhibitors, adalimumab and infliximab, for Crohn's disease. *Health Technol Assess* 15:1–244
77. Loftus EV Jr, Johnson SJ, Wang ST, Wu E, Mulani PM, Chao J (2011) Risk-benefit analysis of adalimumab versus traditional non-biologic therapies for patients with Crohn's disease. *Inflamm Bowel Dis* 17:127–140
78. Jackson DY (2002) Alpha 4 integrin antagonists. *Curr Pharm Des* 8:1229–1253
79. Rutgeerts P, Sandborn WJ, Feagan BG, Reinisch W, Olson A, Johanns J, Travers S, Rachmilewitz D, Hanauer SB, Lichtenstein GR, de Villiers WJ, Present D, Sands BE, Colombel JF (2005) Infliximab for induction and maintenance therapy for ulcerative colitis. *N Engl J Med* 353:2462–2476
80. Goh L, Samanta A (2009) A systematic MEDLINE analysis of therapeutic approaches in ankylosing spondylitis. *Rheumatol Int* 29:1123–1135
81. van den Bosch F, Beaten D, Kruijthof E, DeKeyser F, Mielants H, Veys EM (2001) Treatment of active spondyloarthritis with infliximab, the chimeric monoclonal antibody to tumour necrosis factor alpha. *Ann Rheum Dis* 60(suppl 3):iii33–iii36

82. Brandt J, Haibel H, Reddig J, Sieper J, Braun J (2002) Successful short term treatment of severe undifferentiated spondyloarthropathy with the anti-tumor necrosis factor-alpha monoclonal antibody infliximab. *J Rheumatol* 29:118–122
83. Kruithof E, Van den Bosch F, Baeten D, Herssens A, De Keyser F, Mielants H, Veys EM (2002) Repeated infusions of infliximab, a chimeric anti-TNF α monoclonal antibody, in patients with active spondyloarthropathy: one year follow up. *Ann Rheum Dis* 61:207–212
84. Braun J, Brandt J, Listing J, Zink A, Alten R, Golder W, Gromnica-Ihle E, Kellner H, Krause A, Schneider M, Sørensen H, Zeidler H, Thriene W, Sieper J (2002) Treatment of active ankylosing spondylitis with infliximab: a randomised controlled multicentre trial. *Lancet* 359:1187–1193
85. Gorman JD, Sack KE, Davis JC (2000) Etanercept in the treatment of ankylosing spondylitis: a randomized, double-blind, placebo-controlled study. *Arthritis Rheum* 43:S403
86. Lovell DJ, Giannini EH, Reiff A, Cawkwell GD, Silverman ED, Nocton JJ, Stein LD, Gedalia A, Ilowite NT, Wallace CA, Whitmore J, Finck BK (2000) Etanercept in children with polyarticular juvenile rheumatoid arthritis. *Pediatric Rheumatology Collaborative Study Group. N Engl J Med* 342:763–769
87. Kietz DA, Pepmueller PH, Moore TL (2002) Therapeutic use of etanercept in polyarticular course juvenile idiopathic arthritis over a two year period. *Ann Rheum Dis* 61:171–173
88. De La Mata J, Maese J, Martinez JA, Rosario P, Loza E (2011) Current evidence of the management of undifferentiated spondyloarthritis: a systematic literature review. *Semin Arthritis Rheum* 40:421–429
89. Chaitow J, De Benedetti F, Brunner H et al (2010) Tocilizumab in patients with systemic juvenile idiopathic arthritis: efficacy data from the placebo-controlled 12-week part of the phase 3 TENDER Trial. *Ann Rheum Dis* 69(suppl 3):146
90. Chaudhari U, Romano P, Mulcahy LD, Dooley LT, Baker DG, Gottlieb AB (2001) Efficacy and safety of infliximab monotherapy for plaque-type psoriasis: a randomised trial. *Lancet* 357:1842–1847
91. Mease PJ (2002) Tumor necrosis factor (TNF) in psoriatic arthritis: pathophysiology and treatment with TNF inhibitors. *Ann Rheum Dis* 61:298–304
92. Mease PJ, Goffe BS, Metz J, VanderStoep A, Finck B, Burge DJ (2000) Etanercept in the treatment of psoriatic arthritis and psoriasis: a randomised trial. *Lancet* 356:385–390
93. Dommasch ED, Abuabara K, Shin DB, Nguyen J, Troxel AB, Gelfand JM (2011) The risk of infection and malignancy with tumor necrosis factor antagonists in adults with psoriatic disease: a systematic review and meta-analysis of randomized controlled trials. *J Am Acad Dermatol* 64:1035–1050
94. Rodgers M., Epstein D., Bojke L., et al. (2011) Etanercept, infliximab and adalimumab for the treatment of psoriatic arthritis: a systematic review and economic evaluation. *Health Technol Assess* 15:i–xxi, 1–329
95. Saad AA, Symmons DP, Noyce PR, Ashcroft DM (2008) Risks and benefits of tumor necrosis factor-alpha inhibitors in the management of psoriatic arthritis: systematic review and metaanalysis of randomized controlled trials. *J Rheumatol* 35:883–890
96. Pham T, Fautrel B, Dernis E et al (2007) Recommendations of the French Society for Rheumatology regarding TNF α antagonist therapy in patients with ankylosing spondylitis or psoriatic arthritis: 2007 update. *Joint Bone Spine* 74:638–646
97. Doherty SD, van Voorhees A, Lebwohl MG, Korman NJ, Young MS, Hsu S, Foundation NP (2008) National Psoriasis Foundation consensus statement on screening for latent tuberculosis infection in patients with psoriasis treated with systemic and biologic agents. *J Am Acad Dermatol* 59:209–217
98. Ellis CN, Krueger GG, Alefacept Clinical Study Group (2001) Treatment of chronic plaque psoriasis by selective targeting of memory effector T lymphocytes. *N Engl J Med* 345:248–255
99. Stone JH, Uhlfelder ML, Hellmann DB, Crook S, Bedocs NM, Hoffman GS (2001) Etanercept combined with conventional treatment in Wegener's granulomatosis: a six-month open-label trial to evaluate safety. *Arthritis Rheum* 44:1149–1154
100. Ellman MH, MacDonald PA, Hayes FA (2000) Etanercept as treatment for diffuse scleroderma: a pilot study. *Arthritis Rheum* 43(Suppl.): S392
101. Reiff A, Takei S, Sadeghi S, Stout A, Shaham B, Bernstein B, Gallagher K, Stout T (2001) Etanercept therapy in children with treatment-resistant uveitis. *Arthritis Rheum* 44:1411–1415
102. Nussenblatt RB, Fortin E, Schiffman R, Rizzo L, Smith J, van Veldhuisen P, Sran P, Yaffe A, Goldman CK, Waldmann TA, Whitcup SM (1999) Treatment of noninfectious intermediate and posterior uveitis with the humanized anti-Tac mAb: a phase I/II clinical trial. *Proc Natl Acad Sci USA* 96:7462–7466

103. Tubridy N, Behan PO, Capildeo R, Chaudhuri A, Forbes R, Hawkins CP, Hughes RA, Palace J, Sharrack B, Swingle R, Young C, Moseley IF, MacManus DG, Donoghue S, Miller DH (1999) The effect of anti-alpha4 integrin antibody on brain lesion activity in MS. The UK Antegen Study Group. *Neurology* 53:466-472

Chapter 4

Therapeutic Human Monoclonal Antibodies Against Cancer

Jamie Jarboe, Anumeha Gupta, and Wasif Saif

Abstract

There are over 30 monoclonal antibodies that are FDA approved for a variety of diseases ranging from malignancies to autoimmune diseases to macular degeneration. These antibodies include murine, fully humanized, and chimeric antibodies. There are a number of monoclonal antibodies used in the treatment of malignancies; in fact, three of the top five grossing antibodies (bevacizumab, trastuzumab, and rituximab) are used in oncology Scolnik (mAbs 1:179–184, 2009).

Key words Cancer, Monoclonal antibodies, Bevacizumab, Rituximab, Trastuzumab

1 Development of Monoclonal Antibodies

Monoclonal antibodies are created by injecting human cancer cells, or proteins from cancer cells, into mice. The mouse immune systems respond by creating antibodies against these foreign antigens. The murine cells producing the antibodies are then removed and fused with laboratory-grown cells to create hybrid cells called hybridomas. Hybridomas can indefinitely produce large quantities of these pure antibodies. Monoclonal antibodies can be developed to act against cell growth factors, thus blocking cancer cell growth. Monoclonal antibodies can be conjugated or linked to anticancer drugs, radioisotopes, other biologic response modifiers, or other toxins. When the antibodies bind with antigen-bearing cells, they deliver their load of toxin directly to the tumor. Monoclonal antibodies may also be used to preferentially select normal stem cells from bone marrow or blood in preparation for a hematopoietic stem cell transplant in patients with cancer [1–3].

2 Mechanism of Action

Monoclonal antibodies achieve their therapeutic effect through multiple direct and indirect mechanisms [4]:

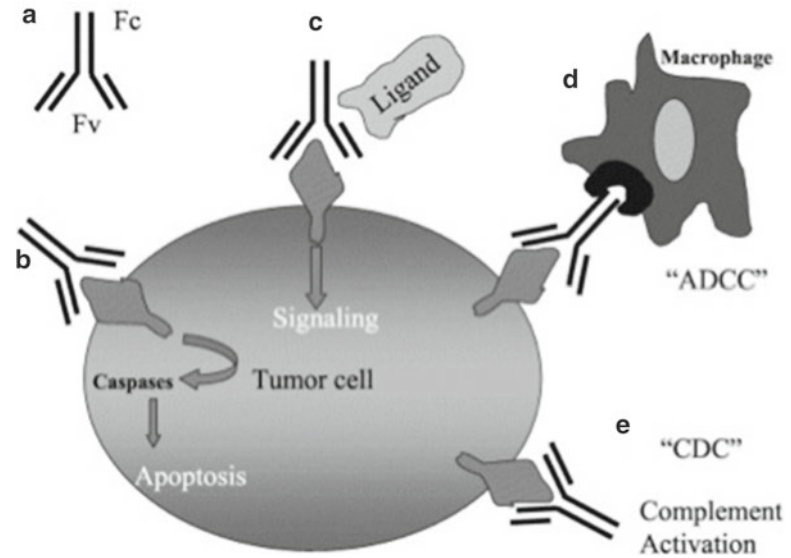

Fig. 1 An illustration of antibody-dependent cell cytotoxicity

1. Can have direct effects in producing apoptosis or programmed cell death.
2. Can block growth factor receptors, effectively arresting proliferation of tumor cells.
3. Can bring about anti-idiotypic antibody formation in cells that express monoclonal antibodies.
4. Recruiting cells that have cytotoxicity, such as monocytes and macrophages. This type of antibody-mediated cell kill is called antibody-dependent cell mediated cytotoxicity (ADCC), Fig. 1.
5. Also bind complement, leading to direct cell toxicity, known as complement dependent cytotoxicity (CDC).

3 Types of Antibodies

Monoclonal antibodies can be placed into one of four categories: murine, chimeric (human–mouse), humanized, and fully human depending upon their structure (Fig. 2). Murine antibodies were the first developed and not surprisingly suffered from immunogenicity problems. Modern recombinant techniques have made it possible to rapidly produce chimeric, humanized, and totally human antibodies. These antibodies have improved efficacy and safety though there are still some issues of immunogenicity [5, 6].

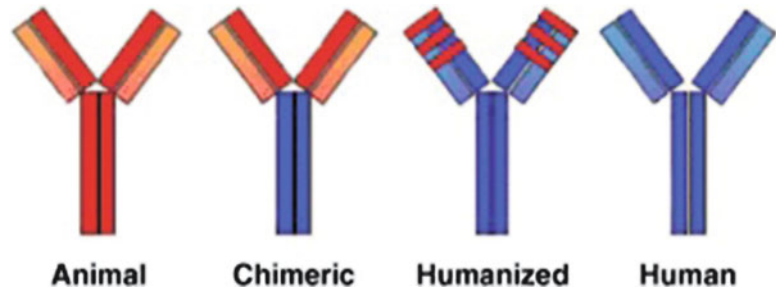

Fig. 2 Monoclonal antibodies

4 Success of Antibodies in Hematology–Oncology

Over 13 antibodies have been approved by the FDA for the treatment of a variety of solid tumors and hematological malignancies (Table 1). In addition, there are a multiple therapeutic and diagnostic antibodies that are currently under testing or development. The most successful story of therapeutic antibodies in patients with solid tumors is with classes of antibodies targeting the EGFR (epidermal growth factor receptor) and VEGF (vascular endothelial growth factor). More importantly, now we have data that aids in patient selection: colorectal cancers bearing wild-type KRAS (kirsten rat sarcoma viral oncogene) tumor treated with anti-EGFR antibodies have improved responses and survival. The use of trastuzumab has also been restricted to patients with either 3+ immunohistochemical staining or fluorescence in situ hybridization positive for ErbB2 (HER2) expression. In the hematologic realm, the most successful target has been CD20 on B-lymphocyte cells.

5 Obstacles to Successful Therapy

There are a number of obstacles to successful therapy with monoclonal antibodies:

1. Antigen distribution of malignant cells is highly heterogeneous, so some cells may express tumor antigens, while others do not.
2. Antigen density can vary as well, with antigens expressed in concentrations too low for monoclonal antibodies to be effective.
3. Tumor blood flow is not always optimal. If monoclonal antibodies need to be delivered via the blood, it may be difficult to reliably get the therapy to the site.
4. High interstitial pressure within the tumor can prevent the passive monoclonal antibodies from binding.

Table 1
FDA approved chimeric and humanized monoclonal antibodies, used in treatment of malignancies

Antibody	Brand name	Company	FDA approval date	Type	Target	Indication
Alemtuzumab	Campath	Genzyme	2001	Humanized	CD52	Chronic lymphocytic leukemia
Bevacizumab	Avastin	Genentech/Roche	2004	Humanized	Vascular endothelial growth factor (VEGF)	Colorectal cancer, nonsmall cell lung cancer, renal cell carcinoma, glioblastoma
Brentuximab vedotin	Adcetris	Seattle Genetics	2011	Chimeric	CD30	Anaplastic large cell lymphoma or Hodgkin lymphoma
Cetuximab	Erbixux	Bristol-Myers Squibb/Lilly	2004	Chimeric	Epidermal growth factor receptor	Colorectal cancer Head and neck cancer
Denosumab	Prolia, Xgeva	Amgen	2010	Human	RANK Ligand inhibitor	Solid tumor bony metastases
Eculizumab	Soliris	Alexion Pharmaceuticals	2007	Humanized	Complement system protein C5	Paroxysmal nocturnal hemoglobinuria
Gemtuzumab	Mylotarg	Wyeth	2000	Humanized	CD33	Acute myelogenous leukemia
Ipilimumab (MDX-101)	Yervoy	Bristol Myers Squibb	2011	Human	Blocks CTLA-4	Melanoma
Ofatumumab	Arzerra	GlaxoSmithKline	2009	Human	CD20	Chronic lymphocytic leukemia
Panitumumab	Vectibix	Amgen	2006	Human	Epidermal growth factor receptor	Colorectal cancer
Pertuzumab	Perjeta	Genentech	2012	Humanized	ErbB2 (HER2)	Breast cancer
Rituximab	Rituxan	Biogen Idec/Genentech	1997	Chimeric	CD20	Non-Hodgkin lymphoma
Tositumomab	Bexxar	GlaxoSmithKline	2003	Human	CD20	Non-Hodgkin lymphoma
Trastuzumab	Herceptin	Genentech	1998	Humanized	ErbB2 (HER2)	Breast cancer, gastrointestinal tumors

5. Since monoclonal antibodies are derived from mouse cell lines, the possibility of an immune response to the antibodies exists. This response not only decreases the efficacy of monoclonal antibody therapy, but also eliminates the possibility of re-treatment.
6. Very rarely do we see cross-reactivity with normal tissue antigens—in general target antigens that are not cross reactive with normal tissue antigens are chosen.

Despite these obstacles, there has been tremendous success in the clinical application of monoclonal antibodies in hematologic malignancies and solid tumors.

6 Clinical Applications of Monoclonal Antibodies

Monoclonal antibodies have several roles in cancer therapy. These antibodies have been used in a variety of ways in the management of cancer including diagnosis, monitoring, and treatment of disease. They aid in diagnosis, such as the application of flow cytometry in the identification of different subsets of non-Hodgkin's lymphoma. We can use monoclonal antibodies to monitor disease progression, such as the measurement of carcinoembryonic antigen in colon cancer. Most importantly, we can utilize monoclonal antibodies directly as therapy [5].

7 Hematologic Malignancies

Focusing solely on hematologic diseases there are currently four fully humanized monoclonal antibodies (alemtuzumab, eculizumab, gemtuzumab, and ofatumumab) and two chimeric antibodies (brentuximab vedotin and rituximab) that are FDA approved.

The first of these approved was Rituximab (brand name Rituxan) [7]. Rituximab is a chimeric monoclonal antibody directed against CD20. CD20 is an antigen expressed on the surface of B lymphocytes. Rixtuximab binds to the CD20 antigen on B lymphocytes facilitating lysis of the lymphocytes and subsequent clearance.

Rituximab was initially developed in the early 1990s for treatment of non-Hodgkin B-cell Lymphoma with FDA approval for this indication coming in 1997. Since that time the use of rituximab has grown widely to encompass not only a variety of B-cell malignancies but also immune-mediated disorders (i.e., rheumatoid arthritis, systemic lupus erythematosus, vasculitis, immune-mediated thrombocytopenia, autoimmune hemolytic anemia, cryoglobulinemia). The FDA approved indications included non-Hodgkin

Lymphoma, Chronic Lymphocytic Leukemia, Rheumatoid Arthritis, Granulomatosis with Polyangiitis, and Microscopic Polyangiitis.

Rituximab is generally viewed as a safe medication and the toxicity profiles determined from a number of clinical trials would confirm this view. The warnings and precautions listed in the prescribing information include infusion reactions, tumor lysis syndrome, severe mucocutaneous reactions, progressive multifocal leukoencephalopathy, hepatitis B virus reactivation, infections, cardiovascular and renal complications.

Rituximab has been studied in a number of clinical trials, which have successfully demonstrated improvement in progressive free and overall survival in non-Hodgkin Lymphoma (including Follicular Lymphoma and Diffuse Large B-cell Lymphoma) as well as improvement in progression free survival in Chronic Lymphocytic Leukemia.

A second chimeric monoclonal antibody, Brentuximab vedotin (brand name Adcetris) was FDA approved in 2011 for the treatment of lymphoma [8]. Brentuximab is a CD30 directed antibody-drug conjugate. It is FDA approved for the treatment of patients with Hodgkin Lymphoma after failure of autologous stem cell transplant or after failure of at least two prior multi-agent chemotherapy regimens in those patients who are not eligible for stem cell transplant. It is also approved for the treatment of patients with systemic Anaplastic Large Cell Lymphoma after failure of at least one prior multi-agent chemotherapy regimen. The approval of Brentuximab for these indications was based upon data supporting improved response rate (without data supporting improvement in progression-free or overall survival). In Hodgkin Lymphoma the overall response rate was 74 % (complete response + partial response). In systemic Anaplastic Large Cell Lymphoma the overall response rate was 86 %.

Clinical trial experience with Brentuximab has demonstrated efficacy as well as a safe toxicity profile. The full prescribing information highlights the common and the more serious potential side effects. These include peripheral neuropathy, infusion reactions, neutropenia, tumor lysis syndrome, progressive multifocal leukoencephalopathy, and Steven–Johnson syndrome. Peripheral neuropathy was predominantly sensory and occurred in 54 % of patients in the clinical trials. Half of the patients saw complete resolution of the neuropathy. Infusion reactions occurred in 12 % of patients in the phase I studies and were all Grade 1 or 2 reactions.

The first humanized monoclonal antibody FDA approved for a hematologic disease was Gemtuzumab ozogamicin (brand name Mylotarg) in 2000 [9]. It was also the first toxin-linked monoclonal antibody approved by the FDA [3]. Gemtuzumab ozogamicin is made up of a cytotoxic antibiotic linked to a recombinant monoclonal antibody directed against the CD33 antigen, which is present on leukemic myeloblasts in most patients with acute myeloid leuke-

mia (AML). It was approved under the accelerated approval regulations for use in patients with CD33 positive AML in first relapse who are over the age of 60 years and not considered candidates for cytotoxic chemotherapy. Approval was based upon a phase II trial that demonstrated a 30 % response rate and was conditional, resting on the future demonstration of benefit in AML patients.

Subsequent trials paired Gemtuzumab ozogamicin with cytotoxic chemotherapies to form therapeutic combinations. It has been shown to be both safe and effective when used in combination for relapsed disease and was also shown to be safe and effective when combined with standard induction chemotherapy in younger patients. One study in particular, SWOG (southwestern oncology group) 106 which added Gemtuzumab ozogamicin to induction chemotherapy in patients under the age of 60 found an increase in 30 day mortality that was uncompensated by improvements in complete response, event-free survival, disease-free survival or overall survival. These findings prompted Pfizer to voluntarily withdraw Gemtuzumab ozogamicin from the market at the request of the FDA in June 2010. Withdrawal occurred prior to results from other randomized trials being made available. Some have made the argument and continue to argue that the withdrawal was premature and should be reversed. This argument finds root in subsequent clinical trials that showed a benefit without increase in toxicity for certain subsets of patients with AML [10, 11].

Alemtuzumab (brand name Campath) was FDA approved in 2001 for the treatment of Chronic Lymphocytic Leukemia (CLL) [12]. It is a humanized monoclonal antibody directed against CD52, a nonmodulating glycosylated peptide antigen that is highly expressed on B-CLL cell (reportedly 500,000 receptors/cell). CD52 is also expressed on normal lymphocytes but not on hematopoietic stem cells. Work on the CD52 antibodies actually began in the 1980s in the United Kingdom. It was initially developed as a murine antibody and subsequently humanized to overcome the immunogenicity of the rodent antibody. It was initially created by immunologists for the prevention of graft-versus-host-disease (GVHD) in allogeneic bone marrow transplant. In 1997, a phase II trial of alemtuzumab was undertaken to evaluate the safety and efficacy in treating patients with CLL who relapsed after standard chemotherapy [13]. The overall response rate was 42 % (including both partial (38 %) and complete response (4 %)).

The current FDA approved indication is for single agent use in patients with B-cell CLL. In 2002, another phase II trial evaluated the use of alemtuzumab as first-line therapy for patients with B-cell CLL [14]. The overall response rate was quite high at 87 %. Neutropenia was the major side effect, occurring to some degree in the majority of patients and in almost a quarter of patients at the worst grade (grade 4). Other reported side effects include infusion reactions, first dose reactions (fever, rigor, fatigue), infections, anemia, and thrombocytopenia.

Eculizumab (brand name Soliris) was FDA approved in 2007 for treatment of patients with paroxysmal nocturnal hemoglobinuria (PNH) with additional approval for treatment of patients with atypical hemolytic uremic syndrome (aHUS) in 2011 [15]. It is a monoclonal antibody that binds to the complement protein C5 with high affinity. Eculizumab is utilized in PNH to reduce red cell hemolysis and in aHUS to inhibit complement-mediated thrombotic microangiopathy. It carries a boxed warning regarding serious meningococcal infections. Life-threatening and fatal meningococcal infections have occurred in patients treated with eculizumab and thus patients should be immunized at least 2 weeks prior to beginning therapy.

Other potential side effects include headache, fever, hypertension, nasopharyngitis, and gastrointestinal disorders (nausea, vomiting). Studies in the PNH population reveal a significant decrease in transfusion requirements among those patients receiving drug versus placebo. In the aHUS population, eculizumab improved platelet counts as well as renal function.

Ofatumumab (brand name Arzerra) is the first humanized anti-CD20 antibody (recall that Rituximab discussed previously is a chimeric antibody directed against CD20). It binds to a novel epitope that includes both small and large loops of the CD20 cell surface antigen; in contrast, rituximab binds to the large loop alone. Ofatumumab received accelerated approval in October 2009 for the treatment of patients with CLL refractory to fludarabine and alemtuzumab based upon interim results of a phase II trial [16]. A total of nine clinical trials have been completed evaluating Ofatumumab in CLL. The overall response rate ranged from 40 to 51 % in these trials even in the Rituximab-refractory patients. The most common adverse events were infusion-related reactions, which occurred in 63 % of patients (the vast majority were grade I or II). Other common or important adverse events were cough, fever, and infections.

Ofatumumab has been evaluated and is currently being evaluated in other hematologic malignancies, including follicular lymphoma, diffuse large B cell lymphoma and Waldenstrom's macroglobulinemia.

Tositumomab is a human antibody directed against CD20 that is coupled to iodine I 131 (I^{131}) (brand name Bexxar) [17]. Tositumomab binds to an extracellular domain of the CD20 molecule and cell death occurs due to ionizing radiation admitted by the I^{131} . It was FDA approved in 2003 for patients with CD20 positive Non-Hodgkin Lymphoma that have progressed during or after rituximab therapy.

I^{131} is a radioisotope of iodine with both beta and gamma emissions. There are a number of radiation precautions that must be carefully followed by patients including maintaining a distance of more than 2 meters from other people. Patients are also required

to take potassium iodine supplementation because I^{131} that detaches from the antibody is typically taken up by the thyroid gland and can result in hypothyroidism. Treatment requires a dosimetric step with biodistribution monitoring followed 1 week later by the actual therapeutic dose. Other potential side effects are severe allergic reactions including anaphylaxis, prolonged, severe cytopenias, secondary malignancies, hypothyroidism, and infections [18].

Efficacy of Tositumomab conjugated to I^{131} was established in a clinical trial of 40 patients with low-grade, transformed low-grade or follicular large-cell lymphoma who had all progressed following at least four cycles of rituximab therapy. The overall response rate was 68 % with a complete response rate of 33 %. Subsequently four other single-arm studies showed similar results. While not FDA approved for frontline therapy, it has been shown to be effective in that setting. It has also been effectively used as consolidation post-chemotherapy and is being evaluated for use in conditioning regimens prior to autologous stem cell transplant [17].

8 Solid Malignancies

8.1 *Gastrointestinal Tumors*

There are currently four FDA approved humanized or chimeric monoclonal antibodies used in the treatment of gastrointestinal malignancies.

Vascular endothelial growth factor (VEGF) is a diffusible glycoprotein produced both by normal and malignant cells. VEGF is a mitogen and plays a very important role in the regulation of angiogenesis for both normal and malignant tissues. It stimulates the growth of new blood vessels to allow for tumor growth and it also maintains the immature blood vessels [19]. Bevacizumab (brand name Avastin) is a humanized monoclonal antibody that binds to VEGF. Through this action, it effectively blocks the activation of key pathways required in angiogenesis by the tumors that utilize VEGF. Currently, there is no established molecular predictor of treatment success with bevacizumab. It is currently approved to treat metastatic colorectal cancer in conjunction with fluoropyrimidine.

A phase II clinical trial completed in 2003 showed that bevacizumab in combination with fluorouracil (FU)/leucovorin (LV) significantly increased the response rate and progression free survival in patients with metastatic colorectal cancer [20]. This led to a key phase III trial published in 2004 which showed a statistically significant improvement in progression free survival and overall survival in patients with metastatic colorectal cancer who were treated with a combination of bevacizumab, irinotecan, bolus fluorouracil, and leucovorin as first line therapy [21]. Additionally, bevacizumab has also shown efficacy in regimens utilizing oxaliplatin in both first and second line settings for metastatic colorectal cancer [22, 23]. It has

also been successfully used in conjunction with cetuximab (anti-EGFR antibody) [24]. This monoclonal antibody is not indicated in the adjuvant setting for colorectal cancer nor is it indicated for use as a single agent. The main side effects associated with bevacizumab include hypertension, proteinuria, bowel perforation (1.5–2 %), arterial thrombotic events (4–5 %) and delayed wound healing. Currently, bevacizumab containing regimens are considered to be standard of care in the treatment of advanced colorectal cancer. There are ongoing trials evaluating the use of bevacizumab in ovarian cancer, melanoma, hepatocellular cancer, and a variety of other solid tumors.

Panitumumab (brand name Vectibix) is a humanized monoclonal antibody that binds to the epidermal growth factor receptor (EGFR). EGFR is a tyrosine kinase receptor and when inhibited, it blocks the phosphorylation and subsequent activation of associated tyrosine kinases [25]. This ultimately leads to decreased production of mediators of cellular growth like VEGF and Interleukin—8. Although EGFR is expressed in normal tissues like the placenta and mammary gland, it is found to be overexpressed in cancers of the colon and the rectum [26]. While the importance of immunohistochemical testing for EGFR expression has been questioned prior to the use of panitumumab, determination of the presence or absence of wildtype KRAS rat sarcoma viral oncogene (KRAS) via fluorescent in situ hybridization (FISH) is a prerequisite prior to starting panitumumab. Clinical studies have shown the drug to have no efficacy in patients with mutated KRAS and metastatic colorectal cancer. FDA approval for panitumumab came in 2006 after a pivotal trial showed improved progression free survival over best supportive care in patients with metastatic colorectal cancer who had progressed on two to three lines of chemotherapy. These results were statistically significant and the patients who benefitted the most were noted to be KRAS wildtype [27]. Panitumumab can be given by itself in the second line setting or in conjunction with chemotherapy in the first and second line settings. It is not indicated for use in the adjuvant setting. Side effects associated with panitumumab include infusion reactions, hypomagnesia, diarrhea, hypersensitivity reactions, dermatological toxicities, and ocular toxicities [28]. Future studies using panitumumab in adjuvant settings for colorectal cancer are needed.

Cetuximab (brand name Erbitux) is a chimeric monoclonal antibody against the extracellular domain of the EGFR. It works by competing with target molecules like epidermal growth factor (EGF) and transforming growth factor alpha (TGF-alpha) [29]. By inhibiting the binding of these target molecules, cetuximab effectively blocks intracellular EGFR signaling and facilitates inhibition of proliferation, angiogenesis, cellular differentiation and stimulates apoptosis. Biomarker testing to rule out KRAS mutation is also required prior to the use of cetuximab. Pivotal clinical trials like CRYSTAL and OPUS showed the efficacy of cetuximab

in patients without the KRAS mutation [30]. Cetuximab is currently approved to be used as monotherapy in the third line setting or in conjunction with systemic chemotherapy in the first and second line settings for treatment of metastatic colorectal cancer [31]. Cetuximab is not currently approved for use in the adjuvant setting. Side effects of cetuximab are similar to other EGFR blocking monoclonal antibodies like panitumumab. In addition, Cetuximab can be associated with a severe hypersensitivity reaction.

The HER2 (ERbB2) growth factor is a member of the ERbB/HER growth factor superfamily, which is composed of HER1 (EGFR), HER2, HER3, and HER4 [32]. Trastuzumab (brand name Herceptin) is a humanized monoclonal antibody that targets the extracellular domain of HER2 receptor. Trastuzumab along with chemotherapy has demonstrated efficacy in metastatic or locally advanced unresectable gastric cancer and gastroesophageal cancer. The ToGA trial, a key phase III clinical trial showed statistically significant efficacy with the use of trastuzumab including improved overall survival and progression free survival [33]. Use of trastuzumab requires demonstration of HER2 expression by immunohistochemistry of at least 3+ or FISH positivity (HER2:CEP 17 ratio of ≥ 2). Side effects of Trastuzumab include left ventricular dysfunction, which is reversible with cessation of the therapy. Therapy has been successfully reinitiated once the ventricular function normalizes without further dysfunction. Trastuzumab is currently being studied for use with chemotherapy in the preoperative (neo-adjuvant) settings. In the metastatic setting, it is used in conjunction with chemotherapy in first and second line settings. Currently there is no role for use as a single agent in metastatic gastric and gastroesophageal cancers.

8.2 Genitourinary Tumors

Based on the fact that most clear cell renal cell carcinomas carry a mutation resulting in constitutive production of cytokines stimulating angiogenesis, many agents that targeted vascular endothelial growth factor (VEGF)-mediated pathways have been developed. In addition to three oral tyrosine kinase inhibitors, pazopanib, sorafenib, and sunitinib, bevacizumab has also been approved by FDA for this indication. Bevacizumab delayed progression of clear cell renal cell carcinoma when compared with placebo in patients with disease refractory to biological therapy [34]. Similarly, bevacizumab plus interferon-alpha as first-line therapy resulted in longer progression free survival but not overall survival compared with interferon alpha alone in two similarly designed randomized controlled trials [35].

Denosumab (brand name Prolia) inhibits RANKL, a protein involved in bone metabolism, and appears to delay bone metastases onset in patients with prostate cancer [36]. RANK-ligand is part of a system of interacting cytokines of the tumor necrosis factor (TNF) family that regulates bone turnover. In the

RANK/RANK-ligand pathway, RANK-ligand, which is secreted by osteoblasts and bone marrow stromal cells, activates RANK on the surface of OCPs, inducing differentiation of precursors into mature cells. This step is antagonized by osteoprotegerin (OPG). This mechanism has been identified in many tumors, of note prostate, multiple myeloma and breast cancer.

8.3 Breast Cancer

Approximately 25 % of patients with breast cancer have tumors that over express HER2/neu [37]. Trastuzumab (brand name Herceptin) has been approved for use as a single agent as well as in combination with chemotherapy in patients with breast cancer:

1. In patients previously treated with cytotoxic chemotherapy whose tumors overexpress HER2/neu, administration of trastuzumab as a single agent resulted in a response rate of 21 % [38].
2. Patients with metastatic disease with chemotherapy plus trastuzumab had an overall survival advantage as compared with those receiving chemotherapy alone (25.1 months vs. 20.3 months, $P=0.05$) [39]. When combined with doxorubicin, trastuzumab is associated with significant cardiac toxicity [40]. Consequently, patients with metastatic breast cancer with substantial overexpression of HER2/neu are candidates for treatment with the combination of trastuzumab and paclitaxel or for clinical studies of trastuzumab combined with taxanes and other chemotherapeutic agents. In one randomized study of patients with metastatic breast cancer treated with trastuzumab, paclitaxel, and carboplatin, patients tolerated the combination well and had a longer time-to-progression, compared to trastuzumab and paclitaxel alone [41].

Pertuzumab (brand name Perjeta) is a humanized, monoclonal antibody that binds to a different epitope at the HER2 extracellular domain than trastuzumab. The binding of pertuzumab to HER2 prevents dimerization with other ligand-activated HER receptors, most notably HER3. The phase III CLEOPATRA study that compared pertuzumab plus trastuzumab plus docetaxel versus placebo plus trastuzumab plus docetaxel, in the first-line HER2+ metastatic setting showed that the median progression free survival was 12.4 months in the control group versus 18.5 months in the pertuzumab group (HR, 0.62; 95 % CI, 0.51–0.75; $P<0.001$). Final OS results are pending. The toxicity profile was similar in both treatment groups with no increase in cardiac toxic effects seen in the pertuzumab combination arm [42].

The role of Bevacizumab in the treatment of metastatic breast cancer remains controversial. ECOG-2100 demonstrated that the addition of bevacizumab to paclitaxel significantly prolonged median progression free survival compared with paclitaxel alone as the initial treatment for patients with metastatic breast cancer (11.8 months vs. 5.9 months; HR, 0.60; $P<0.001$). However, the

addition of bevacizumab did not improve overall survival. In addition, patients on the bevacizumab arm had significantly higher toxicities, including hypertension, proteinuria, cerebrovascular ischemia, and infection [43]. The AVADO trial randomly assigned patients to docetaxel plus either placebo or bevacizumab also showed improved median progression free survival compared with placebo (10.1 months vs. 8.1 months) but did not improve overall survival [44]. Similarly, the RIBBON-1 [45] and RIBBON-2 [46] studies showed similar results. Toxicities associated with bevacizumab were again similar to those seen in prior clinical trials.

8.4 Head and Neck Cancers

Cetuximab (brand name Erbitux; also discussed under gastrointestinal malignancies) recently received full FDA approval for the treatment of patients with locally advanced (with radiation) or metastatic squamous cell carcinoma of the head and neck (HNSCC) (as a single agent). It is also approved for use in a triple drug combination with a platinum and 5-FU, again for patients with recurrent or metastatic disease [47].

Three pivotal trials constitute the supportive data that led to the approval of cetuximab in HNSCC. The initial trial evaluated cetuximab plus radiation compared to radiation alone. The overall survival in the experimental arm was 50 months compared to 30 months in the radiation alone arm [48]. Locoregional control also showed a statistically significant improvement with the addition of cetuximab. A second trial completed in Europe evaluated the triple drug combination (cetuximab plus a platinum and 5FU) versus a platinum and 5FU. Overall survival was improved by 3 months in the experimental arm with a statistically significant improvement in objective response rate. The third study was a single arm study evaluating the use of cetuximab as a single agent in patients with recurrent or metastatic HNSCC. The objective response rate was unimpressive at 13 % but still meaningful for this difficult to treat population.

Considerable work remains to be done, particularly to enhance our understanding of factors that may predict for favorable response to EGFR inhibitor therapy and to evaluate the impact of integrating anti-EGFR therapies into complex chemoradiation programs delivered with curative intent [49].

8.5 Lung Cancer

Bevacizumab (brand name Avastin, discussed above under gastrointestinal malignancies and breast cancer) is also FDA approved for the treatment of non-small cell lung cancer (NSCLC). The approval is specifically for use with carboplatin and paclitaxel as first line treatment of unresectable, locally advanced, recurrent or metastatic disease [50]. Approval came after a single, large, randomized, open-label, multicenter study in patients with locally advanced, metastatic or recurrent non-squamous NSCLC. Patients were

randomized to triple therapy (paclitaxel, carboplatin and bevacizumab) versus a traditional doublet of paclitaxel and carboplatin. Overall survival was improved by 2 months in the experimental arm, which was statistically significant. A second study evaluated bevacizumab in combination with cisplatin and gemcitabine in a similar patient population. This study failed to show a benefit to the addition of bevacizumab and thus it is not FDA approved for use in this combination.

The toxicity profile of bevacizumab in lung cancer is similar to that seen in patients with colorectal or breast cancer and includes hypertension, proteinuria, cerebrovascular ischemia and infection.

Experts disagree about the true benefit of bevacizumab in patients with non-small cell lung cancer. The benefit of bevacizumab is specifically called into question in more recent trials that have included the chemotherapeutic agent, pemetrexed (brand name Alimta). There have been and continue to be a number of trials investigating a variety of combinations for lung cancer as well as investigating the value of maintenance chemotherapy. Lung cancer remains a particularly deadly malignancy that is difficult to treat [51].

8.6 Melanoma

In addition to targeting antigens involved in cancer cell physiology, antibodies can also function to modulate immunological pathways that are critical to immune surveillance.

Ipilimumab (brand name Yervoy) was approved in 2011 for the treatment of unresectable or metastatic melanoma. It is a human cytotoxic T-lymphocyte antigen 4 (CTLA-4)-blocking antibody. It binds to CTLA-3 and blocks its interaction with ligands CD80 and CD86. This blockage augments T-cell activation and proliferation [52]. The exact mechanism of ipilimumab's effect on melanoma is indirect and not entirely understood. Approval was obtained after a randomized double-blind, double-dummy study of over 600 patients with unresectable or metastatic melanoma. The trial actually investigated both Ipilimumab as well as a peptide vaccine. Overall survival was statistically significantly improved in both arms receiving ipilimumab. Due to the nature of this antibody, immune-mediated reactions can be severe and even fatal. Reports of immune-mediated enterocolitis, hepatitis, dermatitis, neuropathies, and endocrinopathies have all been reported. Clinical trial experience suggests that diarrhea, pruritis, and fatigue are the most common adverse reactions experienced. Immune-mediated reactions of any type or severity occurred in approximately 15 % of patients (the majority of these were enterocolitis).

Tremelimumab is another monoclonal antibody that targets CTLA-4 in development; however, results from early phase pivotal trials failed to show a survival advantage and thus it has not been FDA approved for melanoma (or any other malignancy) at this time [53]. It is also being evaluated in the patients with prostate cancer and mesotheliomas [4].

Monoclonal antibodies appeared on the medical treatment scene in the last two decades. As this chapter has detailed there have been successes and failures. The potential for therapeutic benefit remains quite high and thus ongoing investment in and evaluation of monoclonal antibodies will continue. In fact since 2011 over 40 clinical trials have been initiated to evaluate monoclonal antibodies in cancer patients [4].

While there is evidence of clinical response in patients treated with monoclonal antibodies, clinical experience often reveals that the responses are of a short duration. In order to move the field forward, attention must be paid to identifying the appropriate patients for treatment as well as identifying biomarkers that indicate resistance. The currently available monoclonal antibodies are not without side effects and thus continued refinement of development as well as targeting can potentially lead to newer agents with less toxicity. Continued research in the field also has the potential for the development of new technologies, which could improve production resulting in larger quantities and thus more affordable antibodies. Monoclonal antibodies play an important role in cancer therapy and will continue to increase in importance for the foreseeable future.

References

1. Chapman K et al (2009) Preclinical development of monoclonal antibodies. *MAbs* 1(5):505–516
2. Riechmann L (1988) Reshaping human antibodies for therapy. *Nature* 332:323–327
3. Waldman T (2003) Immunotherapy: past, present, and future. *Nat Med* 9:269–277
4. Vacchelli E, Eggermont A, Galon J et al (2013) Trial watch: monoclonal antibodies in cancer therapy. *Oncoimmunology* 2(1):e22789
5. Harding F et al (2010) The immunogenicity of humanized and fully human antibodies: residual immunogenicity resides in the CDR regions. *MAbs* 2(3):256–265
6. Mahapatra M et al (2011) Monoclonal antibodies in hematology. *Med Update* 24:455–458
7. Rituximab (Rituxan) prescribing information.
8. Adcetris (brentuximab vedotin) prescribing information.
9. Bross P et al (2001) Approval summary: gemtuzumab ozogamicin in relapsed acute myeloid leukemia. *Clin Cancer Res* 7:1490–1496
10. Ravandi F et al (2012) Gemtuzumab ozogamicin: time to resurrect? *J Clin Oncol* 30:3921–3923
11. van der Velden V et al (2001) Targeting of the CD33-calicheamicin immunoconjugate Mylotarg (CMA-676) in acute myeloid leukemia: in vivo and in vitro saturation and internalization by leukemic and normal myeloid cells. *Blood* 97:3197–3204
12. Ferrajoli A et al (2001) Alemtuzumab: a novel monoclonal antibody. *Expert Opin Biol Ther* 1:1059–1065
13. Osterborg A et al (1997) Phase II multicenter study of human CD52 antibody in previously treated chronic lymphocytic leukemia. *J Clin Oncol* 15:1567–1574
14. Lundin J et al (2002) Phase II trial of subcutaneous anti-CD52 monoclonal antibody alemtuzumab (Campath-1H) as first-line treatment for patients with B-cell chronic lymphocytic leukemia. *Blood* 100:768–773
15. Soliris (eculizumab) prescribing information.
16. Gupta I et al (2012) Ofatumumab, the first human anti-CD20 monoclonal antibody for the treatment of B cell hematologic malignancies. *Ann N Y Acad Sci* 1263:43–56
17. Bexxar prescribing information.
18. Tomblyn M (2012) Radioimmunotherapy from B-cell non-hodgkin lymphomas. *Cancer Control* 19:196–202
19. Kim KJ, Li B, Winer J et al (1993) Inhibition of vascular endothelial growth factor-induced angiogenesis suppresses tumour growth in vivo. *Nature* 362:841–844
20. Kabbinavar F, Hurwitz H, Fehrenbacher L et al (2003) Phase II, randomized trial com-

- paring bevacizumab plus fluorouracil (FU)/Leucovorin (LV) with FU/LV alone in patients with metastatic colorectal cancer. *J Clin Oncol* 21:60–65
21. Hurwitz H, Fehrenbacher L, Novotny W et al (2004) Bevacizumab plus Irinotecan, fluorouracil, and leucovorin for metastatic colorectal cancer. *N Engl J Med* 350:2335–2342
 22. Glantonio BJ, Catalano PJ, Meropol NJ et al (2007) Bevacizumab in combination with Oxaliplatin, fluorouracil and leucovorin (FOLFOX 4) for previously treated metastatic colorectal cancer: results from the eastern cooperative oncology group study E3200. *J Clin Oncol* 25(12):1539–1544
 23. Saltz LB, Clarke S, Diaz-Rubio E et al (2008) Bevacizumab in combination with oxaliplatin based chemotherapy as first line therapy in metastatic colorectal cancer; a randomized phase 3 study. *J Clin Oncol* 26(12):2013–2019
 24. Saltz LB, Lenz HJ, Kindler HL et al (2007) Randomized phase II trial of cetuximab, bevacizumab, and irinotecan compared with cetuximab and bevacizumab alone in irinotecan refractory colorectal cancer: the BOND-2 study. *J Clin Oncol* 25(9):4557–4561
 25. Van Cutsem E (2006) Challenges in the use of epidermal growth factor receptor inhibitors in colorectal cancer. *Oncologist* 11:1010–1017
 26. US Food and Drug Administration. Vectibix™ (panitumumab). Available at <http://www.fda.gov/cder/foi/label/2006/1251471bl.pdf>. Accessed April 11, 2007
 27. Van Cutsem E, Peeters M, Siena S et al (2007) Open label phase 3 trial of panitumumab plus best supportive care compared with best supportive care alone in patients with chemotherapy refractory metastatic colorectal cancer. *J Clin Oncol* 25(13):1658–1664
 28. Ruthann MG, Kaushikkumar AS, Cohen MH et al (2007) FDA drug approval summary Panitumumab (Vectibix). *Oncologist* 12:577–583
 29. Holubec L, Liska V, Matejka VM et al (2012) The role of cetuximab in the treatment of metastatic colorectal cancer. *Anticancer Res* 32:4007–4012
 30. Van Cutsem E, Kohne CH, Lang I et al (2011) Cetuximab plus irinotecan, fluorouracil, and leucovorin as first line treatment for metastatic colorectal cancer: updated analysis of overall survival according to tumor KRAS and BRAF mutation status. *J Clin Oncol* 29(15):2009–2011
 31. Van Cutsem E, Kohne CH, Hitre E et al (2009) Cetuximab and chemotherapy as initial treatment for metastatic colorectal cancer. *N Engl J Med* 360(14):1408–1417
 32. Hynes NE, Lane HA (2005) ERBB receptors and cancer: the complexity of targeted inhibitors. *Nat Rev Cancer* 5:341–354
 33. Bang Y-J, Van Cutsem E, Feyereislova A et al (2010) Trastuzumab in combination with chemotherapy versus chemotherapy alone for treatment of HER2-positive advanced gastric or gastro-oesophageal junction advanced gastric or gastro-oesophageal junction cancer (ToGA): A phase 3, open-label, randomized controlled trial. *Lancet* 376(9742):687–697
 34. Yang JC, Haworth L, Sherry RM et al (2003) A randomized trial of bevacizumab, an anti-vascular endothelial growth factor antibody, for metastatic renal cancer. *N Engl J Med* 349(5):427–434
 35. Escudier B, Bellmunt J, Négrier S et al (2010) Phase III trial of bevacizumab plus interferon alfa-2a in patients with metastatic renal cell carcinoma (AVOREN): final analysis of overall survival. *J Clin Oncol* 28(13):2144–2150
 36. Lipton A, Fizazi K, Stopeck AT, Henry DH, Brown JE, Yardley DA, Richardson GE, Siena S, Maroto P, Clemens M, Bilynsky B, Charu V, Beuzeboc P, Rader M, Viniegra M, Saad F, Ke C, Braun A, Jun S (2012) Superiority of denosumab to zoledronic acid for prevention of skeletal-related events: a combined analysis of 3 pivotal, randomised, phase 3 trials. *Eur J Cancer* 48(16):3082–3092
 37. Pegram MD, Pauletti G, Slamon DJ (1998) HER-2/neu as a predictive marker of response to breast cancer therapy. *Breast Cancer Res Treat* 52(1–3):65–77 [PUBMED Abstract]
 38. Cobleigh MA, Vogel CL, Tripathy D et al (1999) Multinational study of the efficacy and safety of humanized anti-HER2 monoclonal antibody in women who have HER2-overexpressing metastatic breast cancer that has progressed after chemotherapy for metastatic disease. *J Clin Oncol* 17(9):2639–2648
 39. Slamon DJ, Leyland-Jones B, Shak S et al (2001) Use of chemotherapy plus a monoclonal antibody against HER2 for metastatic breast cancer that overexpresses HER2. *N Engl J Med* 344(11):783–792
 40. Seidman A, Hudis C, Pierri MK et al (2002) Cardiac dysfunction in the trastuzumab clinical trials experience. *J Clin Oncol* 20(5):1215–1221
 41. Robert N, Leyland-Jones B, Asmar L et al (2006) Randomized phase III study of trastuzumab, paclitaxel, and carboplatin compared with trastuzumab and paclitaxel in women with HER-2-overexpressing metastatic breast cancer. *J Clin Oncol* 24(18):2786–2792
 42. Baselga J, Cortés J, Kim SB et al (2012) Pertuzumab plus trastuzumab plus docetaxel

- for metastatic breast cancer. *N Engl J Med* 366(2):109–119
43. Miller K, Wang M, Gralow J et al (2007) Paclitaxel plus bevacizumab versus paclitaxel alone for metastatic breast cancer. *N Engl J Med* 357(26):2666–2676
 44. Miles DW, Chan A, Dirix LY et al (2010) Phase III study of bevacizumab plus docetaxel compared with placebo plus docetaxel for the first-line treatment of human epidermal growth factor receptor 2-negative metastatic breast cancer. *J Clin Oncol* 28(20):3239–3247
 45. Robert NJ, Diéras V, Glaspy J et al (2011) RIBBON-1: randomized, double-blind, placebo-controlled, phase III trial of chemotherapy with or without bevacizumab for first-line treatment of human epidermal growth factor receptor 2-negative, locally recurrent or metastatic breast cancer. *J Clin Oncol* 29(10):1252–1260
 46. Brufsky AM, Hurvitz S, Perez E et al (2011) RIBBON-2: a randomized, double-blind, placebo-controlled, phase III trial evaluating the efficacy and safety of bevacizumab in combination with chemotherapy for second-line treatment of human epidermal growth factor receptor 2-negative metastatic breast cancer. *J Clin Oncol* 29(32):4286–4293
 47. Erbitux (cetuximab), prescribing information.
 48. Astsaturov I, Cohen RB, Harari P (2007) EGFR-targeting monoclonal antibodies in head and neck cancer. *Curr Cancer Drug Targets* 7(7):650–665
 49. Russell J et al (2012) The Use of epidermal growth factor receptor monoclonal antibodies in squamous cell carcinoma of the head and neck. *Chemother Res Pract* 1–13
 50. Avastin (bevacizumab), prescribing information.
 51. Vokes E et al (2013) Evidence-based role of bevacizumab in non-small cell lung cancer. *Ann Oncol* 24:6–9
 52. Yervoy (ipilimumab) prescribing information.
 53. Rughani M et al (2013) New treatment approaches in melanoma: current research and clinical prospects. *Ther Adv Med Oncol* 5:73–80

Chapter 5

Polyclonal and Monoclonal Antibodies in Clinic

Bharath Wootla, Aleksandar Denic, and Moses Rodriguez

Abstract

Immunoglobulins (Ig) or antibodies are heavy plasma proteins, with sugar chains added to amino-acid residues by N-linked glycosylation and occasionally by O-linked glycosylation. The versatility of antibodies is demonstrated by the various functions that they mediate such as neutralization, agglutination, fixation with activation of complement and activation of effector cells. Naturally occurring antibodies protect the organism against harmful pathogens, viruses and infections. In addition, almost any organic chemical induces antibody production of antibodies that would bind specifically to the chemical. These antibodies are often produced from multiple B cell clones and referred to as polyclonal antibodies. In recent years, scientists have exploited the highly evolved machinery of the immune system to produce structurally and functionally complex molecules such as antibodies from a single B clone, heralding the era of monoclonal antibodies. Most of the antibodies currently in the clinic, target components of the immune system, are not curative and seek to alleviate symptoms rather than cure disease. Our group used a novel strategy to identify reparative human monoclonal antibodies distinct from conventional antibodies. In this chapter, we discuss the therapeutic relevance of both polyclonal and monoclonal antibodies in clinic.

Key words Antibody, Polyclonal antibodies, Monoclonal antibodies, Disorders

1 Introduction

Antibodies are naturally occurring proteins that function as antigen-binding entities on the B cell membrane, which are also secreted by plasma cells. Secreted antibodies are versatile and mediate a variety of functions such as neutralization, agglutination, fixation with activation of complement and activation of effector cells. Antibodies fight infections, viruses and other pathogenic substances. When a pathogen enters an immune competent individual, the immune system has the genetic capacity to generate a multitude of antibodies that can target any antigen. The membrane-bound antibody confers antigenic specificity on B cells; the interaction of the membrane antibody with an antigen induces antigen-specific proliferation of B cell clones. Thus, the combination of diversity and specificity makes antibodies a crucial component of the defense mechanism against harmful pathogens.

Natural antibodies, i.e., those antibodies derived from multiple B cell clones (polyclonal) and produced in the absence of deliberate immunization within and outside the immune system, have been shown to prevent autoimmune manifestations in autoimmune animal models and in patients with autoimmune disorders. Another common approach to treat human disorders is to use homogenous antibody preparations, obtained from a single B cell clone (monoclonal). In this chapter, we review available information on the types of polyclonal and monoclonal antibodies being used in the clinical setting.

2 Polyclonal Antibodies

2.1 *Historical Narrative*

In 1890 von Behring discovered that serum of rabbits immunized with tetanus toxin protected experimental animals against tetanus [1]. Encouraged by this finding, Behring successfully applied this strategy to treat diphtheria in children [2]. For his discovery and work, which led to dramatic reduction of diphtheria, in 1901, Emil von Behring received the first Nobel Prize for Physiology and Medicine [3, 4]. This pivotal work opened new avenues in medical research and heralded the use of serum therapy to treat a wide range of infectious diseases using sera prepared against allergic sensitization, toxins, microorganisms and cancers. However, convalescent serum, obtained from people who recovered from infectious diseases, was found to be more effective than animal serum. In 1918, Nicolle and Conseil, two French physicians, reported on the successful use of convalescent serum in the prophylaxis of measles [5]. In 1920, Degkwitz published the first account of a series of over 700 patients successfully inoculated for passive immunization against measles, which led to further interest in human convalescent serum [6]. Advances in biochemical techniques led to the discovery that antibodies are part of the gammaglobulin fraction of serum and hence could be isolated. This discovery provided means to use polyclonal antibodies in the clinical setting [7].

2.2 *Polyclonal Antibodies in Clinic*

In the late 1930s, it was demonstrated that injecting antibodies obtained from human placentas could prevent measles [8]. The development of new techniques in large-scale plasma fractionation and antibody isolation facilitated the use of immunoglobulin preparations to prevent or treat measles, mumps, poliomyelitis, hepatitis and pertussis [9]. In 1952, Bruton reported on X-linked agammaglobulinemia (also called as Bruton's syndrome), a condition in which the individual lacks gammaglobulin fraction in serum, and its successful treatment via intramuscular injections of IgG immunoglobulin obtained by fractionating human plasma [10]. Polyclonal serum actually represents random sets of many antibodies directed to multiple epitopes of multiple antigens. Immunoglobulin G (IgG)

antibodies are the most common antibodies present in circulation of healthy individuals. However, the quantity of Ig that could be administered via intramuscular route was limited, and higher quantities often led to severe anaphylactic reactions. In 1962, Barandun et al. attempted to administer higher quantities of immunoglobulin intravenously in primary immunodeficient patients (PID) but found a high incidence of systemic reactions [11]. This led to the development of isolation procedures at acidic pH (e.g., pH 4.0) in the presence of trace amounts of pepsin (to prevent aggregation of molecules) and the addition of sugars or amino acids as stabilizers that proved safer when administered intravenously. Cutter Biologicals (under the trade name of Gamimune) and Sandoz Pharmaceuticals (now Novartis under the trade name of Sandoglobulin) marketed the first immunoglobulin therapeutic products for widespread intravenous use to replace intramuscular treatments [12]. In contrast to antibody components of serum therapy, intravenous IgG preparations consist of “natural antibodies” or antibodies generated in the absence of deliberate immunization or vaccination regimens. Most of these antibodies are auto- and poly-reactive and hence can be denoted as “natural autoantibodies” [13].

2.3 Intravenous Immunoglobulin

Plasma pools of at least 10,000 healthy donors are necessary to prepare intravenous immunoglobulin (IVIg). The advantage of large donor pools is increased reactivity of individual antibodies to certain antigens. However, given the multitude of reactivities, large donor pools also carry the risk of losing useful rare activity. Theoretically, IVIg comprises the entire range of reactivity exhibited by IgG of normal human sera. The reactivity can target foreign antigens, including bacterial and viral antigens, as well as self-antigens such as membrane-associated self-molecules, intracellular and extracellular antigens. It was found that the self-reactivity of normal serum IgG with solubilized extracts of normal homologous tissues targeted a conserved and limited set of dominant antigens [14–16]. The constant interaction between antibodies, antibody molecules and variable regions of antigen receptors on B cells is an essential component of selection of immune repertoires and establishment of tolerance to self [17, 18].

2.3.1 Components of IVIg Preparations, Production Process and Product Safety

Intact IgG molecules form the primary component of IVIg. Commercial manufacturers as well as not-for-profit organizations produce IVIg. Due to the presence of diverse manufacturers in the market, the purity, pH, osmolarity, sodium and sugar content vary between IVIg preparations [19]. The product undergoes viral inactivation and may contain trace amounts of IgA, anti-A and anti-B (IgG antibodies directed against human blood group antigens), soluble CD4, CD8, HLA molecules and certain cytokines [20–22]. Most of the methodology used to isolate and purify IVIg dates back to the late 1950s. The currently used

methodology includes caprylate precipitation followed by anion exchange chromatography [23]. Characteristics of commercially prepared IVIg are a pH in the range of 4–6, with ≥ 240 mosmol/kg, a total protein quantity of ≥ 30 g/l with ≤ 3 % of immune aggregates. Finally, the product should test negative for HBsAg, HIV p24 antigen, anti-HIV-1 antibodies, anti-HIV-2 antibodies and anti-HCV antibodies [22].

2.3.2 Clinical Use of IVIg Preparations

After demonstrating an attenuated clearance of platelets in a child with immune thrombocytopenic purpura (ITP) [24] followed by a similar effect in adults with ITP [25], IVIg was licensed for use in ITP. IVIg was also tested and used in the clinic as a replacement low-dose therapy for primary and secondary immunodeficiencies. Diseases in this category include PID [26], X-linked agammaglobulinaemia (XLA), acquired hypogammaglobulinemia, common variable immunodeficiency, X-linked hyper-immunoglobulin (Ig)M, severe combined immunodeficiency, HIV infection, Wiskott–Aldrich syndrome, and selective IgG class deficiency [12, 27]. Other currently licensed indications for IVIg include Kawasaki disease, Guillain–Barré syndrome, and chronic inflammatory demyelinating polyneuropathy (CIDP). However, its initial success in treatment of ITP led to its use in treating many systemic inflammatory and autoimmune disorders affecting the joints, skin, hematopoietic system and central nervous system [27]. Licensed uses account for less than half of the annual worldwide sales of IVIg preparations; most sales are for “off-label” IVIg applications [28]. In addition to antibody-mediated diseases, IVIg is also effective in several disorders caused by derailment of cellular immunity, such as dermatomyositis, multiple sclerosis (MS), graft-versus-host disease (GvHD) in recipients of allogeneic bone marrow transplants and treatment of cellular rejection after organ transplantation [29–31]. Table 1 provides a list of licensed and off-label clinical indications for IVIg.

2.3.3 Mechanisms of Action of IVIg

Infused IVIg has a half-life of 21 days in immunocompetent individuals; however, the beneficial effects of IVIg extend beyond its half-life. This suggests that IVIg therapy not only neutralizes pathogenic antibodies but also induces lasting changes in the cellular compartment of the immune system. We will discuss below our understanding of the immunomodulatory mechanisms of IVIg that explain its beneficial effects.

Effects of IVIg on Inflammation

IVIg has potent anti-inflammatory properties as evidenced in Kawasaki’s disease [32] and juvenile arthritis [33]. The group of Jeffrey Ravetch proposed that a small fraction of Fc-sialylated IgG was a constituent of IVIG with increased protective effect in a mouse model of rheumatoid arthritis (K/BxN) [34–36]. However, a recent study from CSL Behring, a company that manufactures

Table 1**IVIg indications (based on data from US Food and Drug Administration, FDA)**

Labeled indications		Off-label uses
<i>Confirmed efficacy</i>		
B-cell chronic lymphocytic leukemia		Dermatomyositis
Chronic inflammatory demyelinating polyneuropathy		Lambert–Eaton syndrome
Guillain–Barré syndrome (adults)		Multiple myeloma
HIV associated immunodeficiency		Myasthenia gravis
Idiopathic thrombocytopenic purpura		Stiff-person syndrome
Kawasaki disease		
Multifocal motor neuropathy with conduction block		
Post-bone marrow transplantation		
Primary immunodeficiency diseases		
<i>Off-label uses</i>		
Moderate efficacy	Mild efficacy	No/low efficacy
Churg–Strauss syndrome	Autoimmune uveitis	Chronic fatigue syndrome
Guillain–Barré syndrome (children)	Birdshot retinochoroidopathy	Hemophilia
Immune hemolytic anemia	Blistering diseases	Immune urticaria
Immune neutropenia	Connective tissue disorders	Immunodeficiencies associated with adult HIV
Parvovirus B19-associated red cell aplasia	Lyell’s syndrome	Inclusion body myositis
Polymyositis	Recurrent spontaneous abortions	Miller Fisher syndrome
	Severe allergic asthma	Multiple sclerosis
	Stevens-Johnson syndrome	Polymyositis
	Systemic lupus erythematosus	Prophylaxis of infections in neonates
	Systemic vasculitis	

IVIg, characterized biochemically and functionally sialic acid-enriched IgG obtained by *Sambucus nigra* agglutinin (SNA) lectin fractionation. They concluded that the contribution of a single mechanism and, more specifically, the putative contribution of the minor fraction of Fc-sialylated IgG within IVIg have not yet been established in the human system. Their results showed that SNA fractionation of IVIg yields only a minor fraction of highly sialylated IgG, wherein the sialic acid localizes to the Fab region. Interestingly, the tested anti-inflammatory activity was associated with Fab not Fc sialylation [37].

IVIg reduces inflammation in several ways. One of these is the attenuation of complement-mediated damage. IVIg binds to activated components C3b and C4b, thereby preventing the deposition of these components on the surface of targets. IVIg’s ability to

bind C3b and C4b is beneficial in severe dermatomyositis, where decreased plasma levels of membrane-attack complex are observed following administration of IVIg [38]. IVIg's ability to interfere with the activation of complement was originally demonstrated in two in vivo models. Basta et al. used a complement-dependent hepatic clearance of IgM-sensitized guinea pig erythrocytes [39], and another model of acute complement-mediated tissue damage induced by rabbit IgG antibodies to endothelial cells. In the latter model, IVIg was given to guinea pigs 3 h before injection of anti-Forsmann antiserum [40]. Mortality was prevented in 38 % of animals mirrored by a fivefold increase in the median duration of survival. The mechanism involved was IVIg inhibition of C3 and C4 uptake on IgG- and IgM-coated targets. In addition, renal biopsy material from patients with immune complex-mediated glomerulonephritis demonstrated a decrease in the amount of immunoglobulin deposits in glomeruli in vitro in the presence of IVIg [41] or in vivo following treatment [42]. This suggests that IVIg modifies the structure, molecular weight, solubility, and phlogistic potential of complexes in immune complex-mediated conditions.

Another anti-inflammatory mechanism of IVIg allows it to modulate the production of cytokines and cytokine antagonists. In Kawasaki's disease, IVIg down regulates levels of inflammatory cytokine interleukin-1 [43] and up regulates plasma levels of interleukin-1-receptor antagonist [44]. In Guillain-Barré syndrome, IVIg decreases circulating levels of interleukin-1 beta [45]. In vitro, IVIg inhibits the activation of endothelial cells in models of inflammation. Cultured endothelial cells transcribe genes for certain adhesion molecules and cytokines in the presence of both tumor necrosis factor alpha and interleukin-1 beta. IVIg blocks this process when added to cultured endothelial cells [46]. A probable mechanism of action for IVIg in Kawasaki's disease is neutralization of the staphylococcal toxin [47]. Toxin-neutralizing properties of IVIg have also been reported in primary hemolytic-uremic syndrome [48] and in chronic relapsing colitis induced by *Clostridium difficile* [49].

Effects on Monocytes,
Macrophages
and Fc Receptors

IVIg suppresses activated monocytes and macrophages by altering various functional aspects of the genes of patients with Kawasaki disease [50]. IVIg also lowers circulating levels of monocyte- or macrophage-inflammatory cytokines, tumor necrosis factor (TNF)- α and IL-1 β [51]. Immune cells with the help of Fc γ Rs recognize the Fc portion of IgG molecules. Fc γ Rs are immunoglobulin superfamily members that recognize the Fc-component of IgG. The underlying mechanism of IVIg in ITP and other autoantibody-mediated cytopenias is the blockade of Fc γ receptors on macrophages. The evidence for this mechanism was derived from in vitro studies in which blood monocytes isolated from ITP

patients (who received IVIg) demonstrated decreased ability to form rosettes with IgG-coated erythrocytes [52] and from in vivo studies in which IVIg decreased the clearance of anti-D-coated autologous erythrocytes [25]. Other evidence includes the increased platelet count in Rh-positive patients with ITP treated with purified anti-D (Rh) antibody [53]. Treatment with IVIG in non-splenectomized patients with ITP prolonged the clearance of radiolabeled, antibody-coated red blood cells, which suggested competitive inhibition of FcγR-bearing phagocytes in the spleen [54]. Finally, infusions of isolated IgG Fc fractions improved platelet counts in children with ITP, which confirmed the importance of Fc-FcγR interactions in mediating the therapeutic effects of IVIg [55]. IVIg can also interfere with activating FcγRs. As evidence, Abe et al. demonstrated down-regulated activatory FcγRI and FcγRIII on human monocytes in Kawasaki's disease patients after IVIg treatment [50]. Similarly, IVIg treatment in a murine nephritis model down regulated FcγRIV on kidney-infiltrating macrophages [56].

Effects on Granulocytes

Monomeric IgG in IVIg preparations functions as an antagonist of FcγRII and FcγRIIIb, which prevents activation of neutrophils by immune complexes [57]. IVIg activates sialic acid-binding, Ig-like lectin 9 (Siglec), a surface molecule on neutrophils, which results in caspase-dependent and caspase-independent forms of cell death. Neutrophil death was mediated by naturally occurring anti-Siglec-9 autoantibodies present in IVIg. Interestingly, anti-Siglec-9, autoantibody-depleted IVIg failed to induce caspase-independent neutrophil death [58]. In addition, neutrophil recruitment to inflamed areas in a mouse model of sickle cell disease was reduced [59]. IVIg may function through rapid inhibition of neutrophil adhesion in this disease model. However, IVIg also contains naturally occurring antibodies that mimic anti-neutrophil cytoplasmic antibodies and activate neutrophils in a TNFα-dependent and Fc-receptor-independent way [60]. This may explain the adverse effects of IVIg therapy (discussed in section 2.3.4 of this chapter) seen in some patients.

Effects on Natural Killer Cells (NK Cells)

IVIg treatment effectively down regulates elevated peripheral blood NK cells in women with recurrent spontaneous abortions [61], but a meta-analysis found insufficient evidence to warrant its use against primary recurrent miscarriage [62, 63]. In patients with hypogammaglobulinemia or agammaglobulinemia, NK cell activity was significantly lower after therapy, which suggests that IVIg diminishes NK activity in vivo and that reduced NK activity correlates with clinical improvement in ITP and autoimmune neutropenia. In contrast high doses of IVIg in Kawasaki disease resulted in significantly increased activity of NK cells and increased numbers of circulating CD16⁺ cells in the peripheral blood.

Furthermore, a study of patients treated with IVIg for seizure disorders suggests that this effect of IVIg on circulating NK cells is not unique to patients with Kawasaki disease [64]. Finally, dendritic cells (DCs) matured in the presence of IVIg (IVIg-DCs)-activated NK cells and increased their interferon-gamma production and degranulation. Interestingly, activated NK cells induced apoptosis of the majority of IVIg-DCs through antibody-dependent cellular cytotoxicity (ADCC). These results suggest that IVIg modulates the ability of the innate immunity to trigger T-cell activation by influencing the interaction between DCs and NK cells [65]. This modulation downsizes the antigen-presenting pool and inhibits T-cell priming, a mechanism that can downplay activated immune system.

Effects on Dendritic Cells (DCs)

DCs are professional antigen-presenting cells. They play a variety of roles in the pathogenesis of autoimmune disorders, inflammatory conditions and allograft rejection. IVIg inhibits DC differentiation and maturation [66]. In addition, IVIg abrogates DC differentiation induced by interferon-alpha in serum from patients with systemic lupus erythematosus [67]. Bayry et al. reported that both Fc and F(ab')₂ fragments of IVIg mediate DC suppression. This indicates that both FcγR- and non-FcR-mediated signaling events are involved in IVIg-mediated modulation of DC function [66]. The expression of major histocompatibility complex (MHC) class II was also down regulated upon IVIg treatment of DCs. In animals models, intact IVIg, but not F(ab')₂ fragments, suppressed DC expression during both the early and the subsequent fulminant phases of autoimmune giant cell myocarditis [68]. IVIg-treated DCs upon adoptive transfer ameliorated ITP, indicating that IVIg may induce soluble immune complexes in vivo that prime dendritic-cell regulatory activity [69].

Effects on B Cells and Antibodies

IVIg has a high content of anti-idiotypic antibodies. This probably accounts for its autoantibody-neutralizing properties as evidenced in patients with acquired hemophilia, an autoimmune hemophilic condition caused by autoantibodies against factor VIII [70, 71]. In patients with vasculitis, IVIg suppressed levels of anti-neutrophil cytoplasmic autoantibodies [72]. In addition, since IVIg is homologous to natural autoantibodies, it may contain anti-idiotypes to neutralize a wide variety of pathogenic autoantibodies. The effect of IVIg on B cells has been documented as down regulation of specific auto-reactive B cells in mice with severe combined immunodeficiency that received lymphoid cells from patients with autoimmune disease [73, 74]. In vitro, IVIg induces differentiation of human B lymphocytes and the secretion of IgG [75]. IVIg also induces proliferation and immunoglobulin synthesis from B cells of patients with common variable immunodeficiency [76]. These induced antibodies may further control pathogenic

autoantibodies, either by idiotype-mediated mechanisms or by sequestering auto-antigens. However, in contrast to these in vitro findings, IVIg therapy decreased peripheral blood B cells in women with recurrent spontaneous abortion [77].

Effects on T Cells

Tha-In et al. compared the effects of IVIg and calcineurin inhibitors (CNI) on human blood-derived T cells and dendritic cells to explore the possible use of IVIg as prophylaxis in acute rejection and GvHD. Their results demonstrated that IVIg and CNI equally inhibited T-cell proliferation and cytokine production after mitogenic and allogenic stimulation in vitro [78]. The inhibition of T cell activation by IVIg may involve the direct interaction of natural autoantibodies against T cell receptor (TCR), CD4, and MHC class I present in IVIg preparations (as discussed earlier). IVIg is also protective in two distinct models of T cell-mediated autoimmune disease, i.e., encephalomyelitis [79] and uveoretinitis [80]. Achiron et al. have demonstrated that IVIg does not bind to resting rat T cells but binds readily to activated T cells, which indicates that IVIg interacts with T cells via an FcγR-independent mechanism [81]. In a mouse model of atherosclerosis (apoE knockout mice), IVIg treatment reduced IgM antibodies to oxidized low-density lipoprotein and led to inactivation of spleen and lymph node T cells [82]. However, IVIg is not effective in concanavalin A (ConA)-induced hepatitis, where ConA activates T lymphocytes and causes T cell-mediated hepatic injury in mice [83]. Kessel et al. reported that IVIg therapy affects T regulatory cells by increasing their suppressive function [84]. Interestingly, IVIg failed to protect against encephalomyelitis in Treg-cell-depleted mice, suggesting that expansion of CD4⁺CD25⁺ regulatory T cells by IVIg is critical in controlling experimental autoimmune encephalomyelitis [85].

2.3.4 Adverse Effects of IVIg Administration

Therapeutic infusions of IVIg are relatively safe; however, patients may occasionally experience adverse reactions that may be managed by infusion rate, proper dosing, administration route, product selection and the administration of other products before or after the infusion. Mild, expected adverse effects may occur in 24–36 % of patients after high-dose IVIg infusions. Table 2 summarizes some of the adverse effects observed in the clinical setting.

3 Monoclonal Antibodies

3.1 Historical Narrative

Kohler and Milstein were the first to demonstrate that antibody-producing cells isolated from murine spleen could be immortally fused to myeloma cells to make hybridomas able to produce endless supplies of monoclonal antibody with predefined specificity [86]. Kinmann, in 1977, reported that it was possible to produce monoclonal antibodies targeted against any antigen through murine

Table 2
IVIg adverse effects

Expected	Unexpected
Hypo/hypertension	Renal complications
Headache	Thromboembolic events
Post-infusion headache	Viral transmission (rare)
Rashes	Prion transmission (rare)
Flu-like symptoms	Inflammatory reactions
Rigors	Hemolysis
Severe back and leg pains	
Anaphylactoid reactions	

transfection studies [87]. The idea of using monoclonal antibodies in clinic met with a lot of skepticism when originally suggested. The first successful use of a monoclonal antibody in clinic was performed in 1982, in a patient with a B-cell lymphoma using monoclonal anti-idiotypic antibody. The patient achieved a 7-year remission [88]. Despite the skepticism of the 1980s, therapeutic monoclonal antibodies have now grown into profitable business products. The majority of recombinant proteins currently in clinical applications are monoclonal antibodies, with as many as 160 products in studies funded by pharmaceutical companies around the world.

3.2 Monoclonal Antibodies in the Clinic

Therapeutic murine monoclonal antibodies (suffix -omab) were introduced into the clinic during the early 1980s; however, recorded problems included lack of efficacy and rapid clearance due to patients' production of human anti-murine antibodies (HAMA). To overcome these, researchers aimed to decrease immunogenicity and increase the efficacy of the antibodies. The technological revolutions involved the production of monoclonal antibody chimeras derived from mouse (suffix -ximab) and human (suffix -zumab) DNA in order to produce fully functional human antibodies [89, 90]. Finally, fully human monoclonal antibodies (suffix -umab) are produced in the laboratory using transgenic mice or phage display libraries. The genetically engineered, functional human monoclonal antibodies have different rates of clearance in circulation. Therapies using monoclonal antibodies aim to harness the body's host-defense mechanism by activating antibody-dependent cytotoxic pathways or complement-mediated cytotoxic pathways. Monoclonal antibody therapy may also target growth inhibitory pathways and/or apoptotic signaling pathways. Sometimes, monoclonal antibody therapy alone will not bring

about the desired result, so a combination therapy is used. Currently, monoclonal antibody therapies are having a significant impact on many disorders of autoimmune origin and in cancer and can be sub-classified under the following three categories immunological, oncological, and anti-infective. We will discuss a few that are approved for usage by the US FDA in the following pages and summarize them in Table 3.

3.2.1 Immunological Disorders

The dysfunction of immune system leads to immunological disorders. Examples are autoimmune diseases, immune deficiencies, hypersensitivities and transplant rejection.

Autoimmune Disorders

This is a group of disorders in which the immune system considers “self” as “foreign”; hence, the immune system attacks and destroys healthy body tissue. There are more than 80 disorders listed under autoimmune disorders, but the list is incomplete because some of the diseases were only suspected to be autoimmune in nature. Most of the FDA-approved monoclonal antibody drugs for autoimmune conditions target TNF- α signaling. Examples are adalimumab (HUMIRA, fully human monoclonal antibody) [91, 92] and infliximab (Remicade, a mouse–human chimeric antibody) [93]. Both of these antibodies bind to TNF- α and inhibit its interaction with TNF receptors [94–96].

Allergy-Related Asthma

Asthma causes the airways of the lungs to become narrow, swell and produce excess mucus. The main symptoms are difficulty in breathing, coughing, wheezing, and shortness of breath. There is no cure for asthma to date. The FDA-approved drug omalizumab (Xolair) [97–100] targets free immunoglobulin E (IgE) in the blood and interstitial fluid. It also binds to membrane-bound forms of IgE on the surface of membrane-IgE-expressing B lymphocytes. However, omalizumab does not bind to IgE already bound to high-affinity receptors. The antibody is humanized and rarely causes major adverse effects.

Ankylosing Spondylitis

Ankylosing spondylitis (AS), a chronic inflammatory disease of the axial skeleton with variable involvement of peripheral joints and non-articular structures, mainly affects joints in the spine and the sacroiliac joint in the pelvis, which results in the eventual fusion of the spine. There is no cure for AS to date. Tumor necrosis factor-alpha (TNF- α) belongs to the acute phase reaction cytokines and is a cytokine involved in systemic inflammation. It is produced primarily by macrophages. The FDA-approved monoclonal antibody golimumab (Simponi) targets TNF- α and hence is a TNF inhibitor. The drug is also beneficial in conditions where TNF- α is up regulated and promotes inflammatory response, such as rheumatoid arthritis, Crohn’s disease, psoriasis, hidradenitis suppurativa, and refractory asthma [101–103].

Table 3
Therapeutic monoclonal antibodies (approved by US Food and Drug Administration)

Targeted disease	Target antigen	Monoclonal antibody
<i>Immunological</i>		
Autoimmune disorders	Inhibition of TNF- α signaling	Adalimumab Infliximab
Allergy-related asthma	Immunoglobulin E (IgE)	Omalizumab
Ankylosing spondylitis (other indications—rheumatoid arthritis, Crohn’s disease, psoriasis, hidradenitis suppurativa, and refractory asthma)	TNF- α inhibitor	Golimumab
Cardiovascular disease	Inhibition of glycoprotein IIb/IIIa	Abciximab
Cryopyrin-associated periodic syndromes (CAPS)	IL-1 β	Canakinumab
Crohn’s disease	Inhibition of TNF- α signaling	Certolizumab pegol
Macular degeneration	Vascular endothelial growth factor A (VEGF-A)	Ranibizumab
Multiple sclerosis (other indications—Crohn’s disease)	Alpha-4 (α 4) integrin	Natalizumab
Paroxysmal nocturnal hemoglobinuria	Complement system protein C5	Eculizumab
Psoriasis	CD11a	Efalizumab
Rheumatoid arthritis	Anti-IL-6R	Atlizumab
Transplant rejection	IL-2R α receptor (CD25)	Daclizumab Basiliximab
	T cell CD3 receptor	Muromonab-CD3
<i>Oncological</i>		
Acute myelogenous leukemia	CD33	Gemtuzumab
Breast cancer	ErbB2 or HER2	Trastuzumab
Chronic lymphocytic leukemia	CD52	Alemtuzumab
	CD20	Ofatumumab
Colorectal cancer	Epidermal growth factor receptor	Panitumumab Cetuximab
	Vascular endothelial growth factor (VEGF)	Bevacizumab
Hodgkin and non-Hodgkin lymphomas	CD30	Brentuximab vedotin
	CD20	Rituximab Tositumomab Ibritumomab tiuxetan
Melanoma	Blocks CTLA-4	Ipilimumab
Postmenopausal osteoporosis (other indications—solid tumor’s bony metastases)	RANK ligand inhibitor	Denosumab
Systemic lupus erythematosus	Inhibition of B-cell activating factor	Belimumab
<i>Anti-infective</i>		
Respiratory syncytial virus	Epitope of the RSV F protein	Palivizumab

Note: This table lists monoclonal antibodies approved by the US FDA as of this writing. There are more than 150 other monoclonal antibodies in clinical trials worldwide

- Cardiovascular Disease** These are disorders that affect the heart and/or blood vessels and account for the majority of deaths worldwide. Abciximab (ReoPro), a chimeric monoclonal antibody directed against glycoprotein IIb/IIIa receptor, was approved by FDA to be used in angioplastic procedures [104]. Angioplasty is a coronary artery procedure, which can result in complications when platelets aggregate to form blood clots. Abciximab, through its antagonist properties, binds to glycoprotein IIb/IIIa receptor and prevents platelets from aggregating [105]. The drug has a short half-life of about 20 min [106, 107].
- Cryopyrin-Associated Periodic Syndromes** Cryopyrin-associated periodic syndromes (CAPS) refer to a spectrum of inherited auto-inflammatory disorders. They share the same genetic basis and overlapping symptomatology. They include familial cold auto-inflammatory syndrome, Muckle–Wells syndrome, and neonatal-onset multisystem inflammatory disease. All these syndromes have been linked to a mutation in the *NLRP3* gene that encodes cryopyrin and results in abnormal production of interleukin-1 β . IL-1 β is an important mediator of the inflammatory response and is involved in a variety of cellular activities including cell proliferation, differentiation, and apoptosis. The FDA-approved human monoclonal antibody canakinumab (Ilaris) targets IL-1 β and was found to be beneficial in CAPS [108–110].
- Crohn's Disease** This is a form of inflammatory bowel disease (IBD). Also known as regional enteritis, it may affect any part of the gastrointestinal tract (GI) from mouth to anus [111]. In genetically susceptible individuals, Crohn's disease can result from the interplay between environmental, bacterial factors and immunological factors [112]. The GI tract is targeted by autoantibodies, possibly directed against the microbial antigens, which lead to a chronic inflammatory disorder. Recent reports, however, indicate that Crohn's disease is an immune-deficient condition rather than an autoimmune condition [113]. Increased levels of TNF- α play a central pathogenic role in inflammatory bowel disease [114]. The FDA-approved drug, certolizumab pegol (Cimzia), is a monoclonal antibody directed against TNF- α [115–117]. To be more precise, the drug is a humanized anti-TNF pegylated FAb' fragment that successfully demonstrated efficacy in a phase III clinical trial for Crohn's disease [118, 119].
- Macular Degeneration** Age-related macular degeneration affects sharp central vision and is a leading cause of vision loss in older people. There are two kinds of macular degeneration, dry and wet. In the dry form, cellular debris accumulates between the retina and the choroid, which can sometimes lead to detached retina. In the wet, more severe form, blood vessels originating from the choroid grow behind the retina and often lead to retinal detachment. The FDA-approved drug to treat wet macular degeneration is ranibizumab (Lucentis)

[120–123], a Fab fragment derived from bevacizumab (Avastin). Like the parent antibody, ranibizumab binds to VEGF but with a much stronger affinity and can prevent or even reverse vision loss caused by wet macular degradation [124].

Multiple Sclerosis

Multiple sclerosis (MS) is an inflammatory demyelinating disease of the central nervous system (CNS) [125]. The underlying immunological abnormalities in MS lead to various neurological and autoimmune manifestations. The disease is also known as disseminated sclerosis and is characterized by damaged fatty myelin sheaths around the axons of the brain and spinal cord. This process leads to demyelination and scarring with varied clinical presentations and heterogeneous histopathological features. The FDA-approved drug for MS is natalizumab (Tysabri) [126, 127], a humanized monoclonal antibody that binds to the cell adhesion molecule α 4-integrin, a molecule that mediates adhesion and migration of immune cells to organs. By binding to α 4-integrin molecule, natalizumab blocks the entry of both CD4⁺ and CD8⁺ lymphocytes into the brain. Natalizumab reduces the ability of inflammatory immune cells to attach and inhibits their ability to cross blood vessel walls [128, 129]. This drug is very successful in reducing clinical relapses in MS patients [127]. However, natalizumab is now used with caution after the documentation of several cases of progressive multifocal leukoencephalopathy (PML) in treated patients [130]. Bloomgren et al. recently collected data from clinical studies, post-marketing sources and independent Swedish registry to estimate the frequency of PML in MS patients treated with natalizumab. They concluded that MS patients with previous immunosuppressive treatment, prolonged natalizumab treatment, and positive status in regard to anti-JC virus antibodies, have a higher risk of developing PML [131].

Paroxysmal Nocturnal Hemoglobinuria

This is a blood disease characterized by complement-mediated intravascular destruction of RBCs in the blood stream, hemoglobin in the urine and thrombosis. Also known as Marchiafava–Micheli syndrome, it is an acquired, potentially life-threatening disease. The FDA-approved monoclonal antibody eculizumab (Soliris) [132–135] is a humanized IgG2/4 antibody that targets complement component 5, inhibiting its cleavage by the C5 convertase and thus blocking the generation of terminal complement complex C5b-9. A double-blind, randomized, placebo-controlled, multicenter, phase-3 trial concluded that eculizumab is an effective therapy for paroxysmal nocturnal hemoglobinuria [136].

Psoriasis

Psoriasis is a noncontagious, autoimmune skin disease that affects the life cycle of skin cells. In this condition, skin cells rapidly grow causing red patches or, sometimes, thick silvery scales that become dry and itchy. There is no cure for psoriasis, but treatments

can provide significant symptomatic relief. The FDA-approved recombinant human monoclonal antibody efalizumab (Raptiva) [137–139] blocks lymphocyte activation and cell migration to skin tissues. The antibody specifically targets the CD11a subunit of lymphocyte function-associated antigen 1 (LFA-1) found on all T cells and also on B cells, macrophages and neutrophils. The antigen assists in recruitment of immune cells to the site of infection. The drug was voluntarily withdrawn from market due to its association with fatal brain infections along with side effects such as sepsis, viral meningitis, invasive fungal disease, and progressive multifocal leukoencephalopathy [140].

Rheumatoid Arthritis

Rheumatoid arthritis (RA) is a chronic, systemic autoimmune inflammatory disease that manifests as stiffness, synovial joint pain and swelling. If the disease is left untreated for many years, bone and cartilage destruction can occur. The primary mediators of inflammation and destruction are TNF- α , IL-6, IL-1, proteases and chemokines. The FDA-approved monoclonal antibodies infliximab, adalimumab, golimumab, and certolizumab pegol, antibodies that are TNF- α inhibitors (described above), were proven effective in reducing clinical signs of inflammation in RA patients [141]. RA is also categorized as a systemic autoimmune disease due to the presence of autoantibodies that play a pivotal role in chronicity and progression. Administration of rituximab, which targets CD20 on B cell surface, results in the depletion of CD20-positive B cells in the peripheral blood of RA patients, although this depletion in the bone marrow is so minimal in a subset of patients that they do not exhibit a clinical response [142]. An alternative treatment targets IL-6, the pleiotropic pro-inflammatory cytokine produced by monocytes, fibroblasts, and lymphocytes, which affects B-cell proliferation, T-cell activation and diverse physiological and pathological processes [143]. Many reports link serum IL-6 levels proportionally with disease activity [144]. The FDA-approved drug for treatment of RA, atlizumab (Tocilizumab, Actemra, and RoActemra) is a humanized anti-IL-6 receptor (IL-6R) antibody. By targeting IL-6R, atlizumab inhibits the signal transduction process of IL-6 signaling pathway [145].

Systemic Lupus Erythematosus

Systemic lupus erythematosus (SLE) is a systemic disease that can affect any part of the body. This is an autoimmune condition in which autoantibodies attack body's cells and tissues resulting in inflammation. B cell-activating factor (BAFF) is an important cytokine expressed by B cell lineage cells and acts as a potent activator of B cells. BAFF also plays an important role in the proliferation and differentiation of B cells. The FDA-approved human monoclonal antibody belimumab (Benlysta) [146–148] specifically targets and inhibits the biological activity of BAFF. The drug is being tested for its potential use in other autoimmune diseases.

Transplant Rejection

When the recipient's immune system is incompatible with the donor's tissue, rejection of transplanted tissues occurs. There are two kinds of immunologic rejection reactions, humoral and cellular. *Humoral immunity* consists of activated B cells and antibody molecules. *Cellular immunity* occurs when organs are transplanted from a deceased donor or one who meets the criteria for brain death following a major trauma. Once transplanted, the resident dendritic cells of the donor migrate to the recipient's peripheral lymphoid tissue and present the donor's peptides to the recipient's naïve helper T cells. Once primed, the naïve T cells interact with alloreactive killer T cells to transduce apoptotic signals to donor tissue. Immunosuppressive agents such as muromonab-CD3 (Orthoclone OKT3) [149, 150], basiliximab (Simulect), or daclizumab (Zenapax) can reduce rejection of transplanted organs. Muromonab-CD3 is the first monoclonal antibody approved for treatment in humans [151]. It is a murine monoclonal IgG2a antibody directed against CD3 receptor on T cells that helps in the apoptosis of T cells and reduces the risk of transplant rejection [152]. Basiliximab, a chimeric IgG1 antibody [153, 154], and daclizumab, a human antibody [155–157], both target the alpha chain of the IL-2 receptor of T cells to reduce immunogenicity in transplant patients.

3.2.2 Oncological Disorders

The dysfunction in cell division and cell growth processes leads to oncological disorders or cancers. Cancers can lead to an increased number of tissue cells (hyperplasia) or can cause the conversion of one type of mature cell into another type of cell (metaplasia). Sometimes cells of the same tissue can show bizarre cell growth wherein cell size, shape and arrangement differ (dysplasia), cells lose their cellular origin and present with different cellular characteristics, shape and organization (anaplasia) and finally result in uncontrolled cell growth (neoplasia). Common examples are leukemias and lymphomas.

Acute Myelogenous Leukemia

This disease is also known as acute myeloid leukemia (AML), a cancer of the blood cells (myeloid lineage). Patients with AML have problems producing new blood cells due to the rapid accumulation of abnormal white blood cells in the bone marrow. The FDA-approved monoclonal antibody gemtuzumab (Mylotarg) is a humanized anti-CD33 (surface marker expressed on leukemic blast cells and also on normal hematopoietic cells) antibody marketed by Wyeth used in the clinic [158–162] from 2000 until 2010. It showed no overall beneficial effect when compared to other commercially available conventional cancer therapies and was ultimately discontinued due to increased drug-related patient death.

Breast Cancer

Cancer of the breast tissue originates from the inner lining of ducts or lobules. Ducts are tubes that carry milk to the nipple, and

lobules are milk-producing glands. Breast cancer occurs mainly in women; however, rare cases have also been reported in elderly men. Conventional treatments include surgery, immunotherapy, drugs and/or radiation therapy. The FDA-approved drug for certain breast cancers is a humanized monoclonal antibody trastuzumab (Herceptin) marketed by Genentech [163, 164]. Herceptin targets ErbB-2, also known as Human Epidermal Growth Factor Receptor 2 (HER2), Neu, CD340 or p185. HER2 is overexpressed in 25–30 % of breast cancers and predicts a worse prognosis as measured by disease-free survival and lower overall survival [165–170]. The FDA approved this drug in September 1998.

Chronic Lymphocytic Leukemia

This cancer, also known as B-cell chronic lymphocytic leukemia (B-CLL), affects the B lymphocytes. Two of the monoclonal antibodies approved by FDA are alemtuzumab (Campath) [171, 172], a humanized antibody directed against CD52, and ofatumumab [173–175] (Arzerra), a human monoclonal antibody directed against the small and large loops of the CD20 molecule on B cells [176]. Both markers are present on the surface of lymphocytes. While alemtuzumab induces caspase-independent cell death in human B-CLL cells through a lipid raft-dependent mechanism [177], ofatumumab binds to CD20 on the surface of B cells and inhibits the activation of early stage B cells [176].

Colorectal Cancer

This cancer, also known as bowel cancer, is characterized by uncontrolled cell growth in the colon, rectum or appendix. Patients usually suffer from rectal bleeding and anemia, which are sometimes associated with weight loss and changes in bowel habits. EGFR or human epidermal growth factor receptor 1 (HER1) is a receptor for the EGF family of protein ligands [178]. The aberrant activation of the EGF family of receptors is implicated in many human cancers and a rational target for therapeutic monoclonal antibodies. The FDA-approved drugs for colorectal cancer are panitumumab (Vectibix, human antibody) [179–181] and cetuximab (Erbix, chimeric antibody), both of which are directed against EGFR. (Cetuximab is also used in some squamous cell carcinomas of the head and neck.) Another FDA-approved monoclonal antibody is bevacizumab (Avastin) [182], a humanized anti-vascular endothelial growth factor (VEGF) monoclonal antibody. VEGF is a signal protein involved in the process of angiogenesis and vasculogenesis. Many VEGF-producing cancers can grow and metastasize [183].

Hodgkin and Non-Hodgkin Lymphomas

Hodgkin's lymphoma is a cancer of lymphocytes. The disease spreads from one lymph node to another in an orderly fashion. Multinucleated Reed–Sternberg cells (RS cells) are the characteristic histopathological finding of Hodgkin's lymphoma. An example of non-Hodgkin's lymphoma (NHL) is anaplastic large-cell

lymphoma (ALCL). This disease involves aberrant T cells and occurs in both nodal and extra-nodal locations. The characteristic phenomenon in both conditions is a prominent, unusual CD30⁺ phenotype of the affected cells. Brentuximab vedotin (Adcetris) [184, 185] is a chimeric monoclonal antibody–drug conjugate that targets CD30. The antibody is linked to an anti-mitotic agent, monomethyl auristatin E, which is reflected by vedotin in the drug’s name. The drug was approved for use in Hodgkin’s lymphoma and ALCL in August of 2011. NHLs vary significantly in severity from mild to very aggressive. Other monoclonal antibodies approved by FDA for NHLs are rituximab [186, 187], ibritumomab tiuxetan [188, 189], and tositumomab [190–193]. These antibodies all target the B-lymphocyte antigen CD20, an activated-glycosylated phosphoprotein expressed on B cell surface from pro-B phase until maturity. Rituximab is a chimeric monoclonal antibody used in lymphomas or malignant B cells disorders. Ibritumomab tiuxetan is a murine monoclonal antibody, ibritumomab, coupled to a chelator tiuxetan with an added radioactive isotope (yttrium-90). Tositumomab is a murine IgG2a antibody, which is given in sequential follow up with iodine (¹³¹I). Tositumomab (antibody covalently bound to radioactive iodine) emits both beta and gamma radiations to destroy the malignant cells.

Melanoma

Melanocytes are the cells that produce the skin color pigment, melanin. Abnormal division of melanocytes leads to melanoma, a less common type of skin cancer but also dangerous if not diagnosed early. The FDA-approved monoclonal antibody therapy for melanoma is a human antibody, ipilimumab (MDX-101, Yervoy) [194, 195] that targets cytotoxic T lymphocyte-associated antigen-4 (CTLA-4). Abnormal melanocytes produce antigens recognized by dendritic cells and then presented to cytotoxic T lymphocytes (CTLs). CTLs, in turn, recognize and destroy these cells. CTLA-4 recognition of inhibitory signal from dendritic cells turns off the cytotoxic reaction, and ipilimumab blocks this inhibitory pathway thereby allowing CTLs to destroy melanoma cells [196].

Postmenopausal Osteoporosis and Bony Metastases

Osteoporosis occurs when postmenopausal changes in hormonal equilibrium and the consequent reduced mineral density of the bone lead to deterioration of the bone microarchitecture. Bone remodeling is an active process mediated by osteoblasts, cells that build new bone material, and osteoclasts, cells that break down bone tissue. Receptor activator of nuclear factor kappa-B ligand (RANKL) or CD254 is present on osteoblasts and serves to activate osteoclasts. The FDA-approved, fully human monoclonal antibody denosumab (Prolia) [197–200] targets RANKL and blocks the primary signal for bone removal by osteoclasts [201]. The drug is also effective in solid tumor bony metastases, where osteolytic bone destruction leads to weakening [202].

3.2.3 Infectious Diseases

Pathogens in the host organism cause infectious disorders. The disease can be transmissible and results in evident clinical symptoms as a result of infection.

Respiratory Syncytial Virus

Respiratory syncytial virus (RSV) is a virus that causes respiratory tract infections. The virus is the leading cause of pneumonia and bronchiolitis in children. In elderly or immunodeficient individuals, viral infection is associated with mortality and morbidity. The FDA-approved humanized IgG monoclonal antibody palivizumab (Synagis) [203, 204] targets RSV surface fusion protein and blocks virus entry into cells, thereby limiting infection. This is a moderately effective prophylactic antibody available for high-risk children [205].

3.3 Efficacy of Monoclonal Antibodies

The knowledge of well-established and optimized methods for antibody generation resulted in a high success rate of approval by FDA for use in clinic. Most of the approved therapeutic antibodies are partially efficacious and are often well tolerated by the patients. However, monoclonal antibody therapy is *not* the first line of treatment for most disorders. To date, very few are considered curative. Monoclonal antibody therapy is also expensive due to high production costs and the large doses administered to patients. Another reason for high patient cost is that the antibodies cannot be administered orally; hence, the patient is dependent on health care services for their use. In addition, the current therapeutic application is often limited as the antigen-specificity of antibodies is mostly directed to extracellular or cell surface targets. Finally, the use of IgG backbone for clinical application results in inefficient penetration of the blood–brain barrier, leading to difficulties in the use of therapeutic monoclonal antibodies in neurological disorders.

3.4 Novel Use of Monoclonal Antibodies for Regeneration

Our laboratory has employed a novel strategy to identify human monoclonal antibodies that promote CNS protection and repair. We isolated antibodies from the sera of patients with monoclonal gammopathies, using selection criteria of monoclonal immunoglobulin concentration of 3 g/dl or greater and a lack of neurologic or antibody-associated pathologies. The screening strategy we employed involved binding to live CNS tissue (cerebellar slices) [206]. We identified two IgM antibodies (sHIgM22 and sHIgM46) that promoted significant remyelination *in vivo*. We then constructed a recombinant version of sHIgM22 (rHIgM22) by cloning the antibody variable region DNA sequence into an expression vector [207, 208] providing the heavy- and light-chain framework. These repair-promoting natural human antibodies are of IgM isotype and have the characteristics of classic natural autoreactive antibodies. GMP-grade rHIgM22 antibody was purified in gram quantities for formal toxicology studies. The antibody is currently undergoing a Phase I, multi-center, double-blind, randomized, placebo-controlled, dose-escalation study designed to evaluate

safety, tolerability, pharmacokinetics, and immunogenicity of single intravenous administrations of rHIgM22 in patients with all clinical presentations of MS. Using a similar strategy, we identified other monoclonal IgM antibodies as candidates to treat other models of neurologic injury and disease. We described two neuron-binding antibodies (sHIgM12 and sHIgM42) that stimulated neurite extension [209]. A recombinant version of sHIgM12 (rHIgM12) was constructed and synthesized [210]. We recently reported that binding rHIgM12 to the neuronal surface reorganized the membrane and signaled the promotion of axonal outgrowth [211]. A single peripheral dose of rHIgM12 also improved motor function in a virus-induced mouse model of MS [212]. Most importantly, the antibodies were able to cross BBB in animal models of virus-induced neurodegenerative diseases and in control-uninfected animals. Mechanistic studies performed in our laboratory indicate that natural autoantibodies function via intracellular-signaling pathways that promote protection and repair [213, 214]. The use of rHIgM22 to enhance remyelination in humans would be the first attempt to promote regeneration, in contrast to the present therapeutic approaches of most FDA-approved drugs currently in market. The neuron-binding antibody represents a promising candidate for the treatment of a number of neurodegenerative diseases. Similar approaches can be used to generate antibodies for regeneration of other tissues.

4 The Future of Antibody Therapy in Clinic

Recent years have witnessed a shortage of IVIg. Possible reasons include excessive off-label usage, which accounts for more than 50 % of the current worldwide IVIg consumption. Good manufacturing procedures using stringent quality control measures may also account for the ~40 % decreased yield of IVIg. Recombinant monoclonal antibodies offer a possible solution to shortage of IVIg. The combination of efficient screening, safe drug production with efficacy in clinical trials and the ability to produce large quantities of product offers advantages over polyclonal IVIg; however, the beneficial effect of using a single recombinant antibody is limited because no disease is the result of a simple imbalance with a single antigen or pathway. As mentioned above, there are only three therapeutic categories of monoclonal antibodies currently in clinical trials: immunological, oncological, and anti-infective [215]. Further studies that decipher the beneficial effects of mixtures of recombinant monoclonal antibodies are necessary to determine whether recombinant monoclonals can replace IVIg.

IVIgM is an important component discarded during the manufacture of IVIgG. Given the plasma concentration of IgM, ~18 t of pooled IgM may be discarded every year. Studies performed in

the past have documented the beneficial effect of polyclonal human IgM molecules. Thus, IVIgM prevents complement activation *in vitro* and *in vivo* in a rat model of acute inflammation [216] and inhibits classical pathway complement activation, but not bactericidal activity, of human serum [217]. Stehr et al. reported on the use of IgM-enriched solution on polymorphonuclear neutrophil function, bacterial clearance and lung histology in endotoxemia, a condition in which both pro-inflammatory and anti-inflammatory cascade systems are initiated simultaneously like in sepsis. Their results document a striking pulmonary protective effect of IVIgM, enhanced reticuloendothelial system bacterial clearance, increased *in vivo* phagocytosis efficiency, and an especially beneficial effect on LPS-induced pulmonary histological changes [218]. The *in vivo* therapeutic efficacy of IVIgM was also confirmed in experimental models of uveitis, myasthenia gravis, and multiple sclerosis [74, 206, 219, 220]. The mechanisms of action of IVIgM include the induction of apoptosis of lymphoid cell lines and human peripheral blood mononuclear cells [221], the suppression of T cell functions *in vitro* and delay in the activation of T lymphocytes in hu-SCID mice [222]. IVIgM may overcome, at least in part, the shortage of IVIg; however, further work is warranted to appreciate the true beneficial potential of polyclonal IgM antibodies.

Recombinant technology to obtain polyclonal antibodies from healthy donors that represent the pool of IgG/IgM offers the best possible solution to overcome shortages. A critical step in the process is to safeguard the beneficial therapeutic potentials of IVIg and/or IVIgM in the recombinant mixtures. A Copenhagen-based company, Symphogen, developed three new essential techniques to prepare polyclonal antibody pools [223]. The first technology, Symplex™, isolates variable light and heavy region of gene pairs (cognate pairs) from the donors' antibody-producing plasma cells. At this stage, the repertoire of gene pairs can represent the entire donor-antibody response. The second technology, SymSelect™, rapidly screens thousands of antibody mixtures for required biological activity. The third technology, Sympress™, enables the company to produce antibody mixtures of reliable consistency in a single bioreactor [224]. Currently, the company has Sym004 in phase II clinical trials. Sym004 is a mixture of 24 selected anti-EGFR antibodies that were systematically tested in dual and triple mixtures for their ability to inhibit cancer cells *in vitro* and tumor growth *in vivo*. EGFR is frequently dysregulated in human malignancies and a validated target for cancer therapy in humans [225]. Recombinant polyclonal antibodies, a relatively new technology, are considered part of the third generation of antibody therapies and may represent the future of antibody therapy in clinical use.

Financial Support and Acknowledgments

This work was supported by grants from the National Institutes of Health (R01s—GM092993, NS024180, NS032129, NS048357, R21—NS073684), the National Multiple Sclerosis Society (NMSS, CA1060A11), the Applebaum, Hilton and Peterson Foundations, the Minnesota Partnership for Biotechnology and Medical Genomics, and the European Regional Development Fund—Project FNUSA-ICRC (No.CZ.1.05/1.1.00/02.0123). We thank the McNeilus Family. We gratefully acknowledge the Mayo Clinic Center for Translational Science Activities (CTSA) for supporting this project through a High Impact Pilot and Feasibility Award (HIPFA) and a Novel Methodology and Development Award (NMDA). BW and AD are supported through funds from NMSS (CA1060A11) and NINDS R21 NS073684 Clinical Translation award, respectively. The authors gratefully thank Lea C. Dacy for editorial assistance through helpful comments and suggestions.

References

- Behring E, Kitasato S (1890) Ueber das Zustandekommen der Diphtherie-Immunität und der Tetanus-Immunität bei Thieren. *Dtsch Med Wochenschr* 16:1113–1114
- Hallauer C (1954) Emil von Behring, the man and his work. *Schweiz Z Pathol Bakteriol* 17:392–399
- Bochalli R (1956) Alfred Nobel and the German Nobel prize winners for physiology and medicine. *Med Monatsschr* 10:44–45
- Lejeune F (1951) German Nobel Prize winners. *Med Welt* 20:429–435
- Nicolle C, Conseil E (1918) Pouvoir préventif du sérum d'un malade convalescent de rougeole. *Bull Mem Soc Med Hop Paris* 42:337
- Degkwitz R (1920) Über Versuche mit Masernrekonvaleszentenserum. *Ztschr f Kinderh* 25:134
- Rezaei N, Abolhassani H, Aghamohammadi A, Ochs HD (2011) Indications and safety of intravenous and subcutaneous immunoglobulin therapy. *Expert Rev Clin Immunol* 7:301–316
- Mc KC (1937) The prevention and modification of measles. *JAMA* 109:2034–2038
- Eibl MM (2008) History of immunoglobulin replacement. *Immunol Allergy Clin North Am* 28:737–764, viii
- Bruton OC (1952) Agammaglobulinemia. *Pediatrics* 9:722–728
- Barandun S, Kistler P, Jeunet F, Isliker H (1962) Intravenous administration of human gamma-globulin. *Vox Sang* 7:157–174
- Orange JS, Hossny EM, Weiler CR, Ballow M, Berger M, Bonilla FA, Buckley R, Chinen J, El-Gamal Y, Mazer BD, Nelson RP Jr, Patel DD, Secord E, Sorensen RU, Wasserman RL, Cunningham-Rundles C (2006) Use of intravenous immunoglobulin in human disease: a review of evidence by members of the Primary Immunodeficiency Committee of the American Academy of Allergy, Asthma and Immunology. *J Allergy Clin Immunol* 117:S525–S553
- Avrameas S (1991) Natural autoantibodies: from 'horror autotoxicus' to 'gnothi seauton'. *Immunol Today* 12:154–159
- Lacroix-Desmazes S, Mouthon L, Coutinho A, Kazatchkine MD (1995) Analysis of the natural human IgG antibody repertoire: lifelong stability of reactivities towards self antigens contrasts with age-dependent diversification of reactivities against bacterial antigens. *Eur J Immunol* 25:2598–2604
- Mouthon L, Haury M, Lacroix-Desmazes S, Barreau C, Coutinho A, Kazatchkine MD (1995) Analysis of the normal human IgG antibody repertoire. Evidence that IgG autoantibodies of healthy adults recognize a limited and conserved set of protein antigens in homologous tissues. *J Immunol* 154:5769–5778
- Nobrega A, Haury M, Grandien A, Malanchere E, Sundblad A, Coutinho A (1993) Global analysis of antibody repertoires. II. Evidence for specificity, self-selection and

- the immunological “homunculus” of antibodies in normal serum. *Eur J Immunol* 23:2851–2859
17. Varela F, Andersson A, Dietrich G, Sundblad A, Holmberg D, Kazatchkine M, Coutinho A (1991) Population dynamics of natural antibodies in normal and autoimmune individuals. *Proc Natl Acad Sci U S A* 88:5917–5921
 18. Varela FJ, Coutinho A (1991) Second generation immune networks. *Immunol Today* 12:159–166
 19. Gelfand EW (2006) Differences between IGIV products: impact on clinical outcome. *Int Immunopharmacol* 6:592–599
 20. Lam L, Whitsett CF, McNicholl JM, Hodge TW, Hooper J (1993) Immunologically active proteins in intravenous immunoglobulin. *Lancet* 342:678
 21. Blasczyk R, Westhoff U, Grosse-Wilde H (1993) Soluble CD4, CD8, and HLA molecules in commercial immunoglobulin preparations. *Lancet* 341:789–790
 22. Bayry J, Negi VS, Kaveri SV (2011) Intravenous immunoglobulin therapy in rheumatic diseases. *Nat Rev Rheumatol* 7:349–359
 23. Buchacher A, Iberer G (2006) Purification of intravenous immunoglobulin G from human plasma—aspects of yield and virus safety. *Biotechnol J* 1:148–163
 24. Imbach P, Barandun S, d’Apuzzo V, Baumgartner C, Hirt A, Morell A, Rossi E, Schoni M, Vest M, Wagner HP (1981) High-dose intravenous gammaglobulin for idiopathic thrombocytopenic purpura in childhood. *Lancet* 1:1228–1231
 25. Fehr J, Hofmann V, Kappeler U (1982) Transient reversal of thrombocytopenia in idiopathic thrombocytopenic purpura by high-dose intravenous gamma globulin. *N Engl J Med* 306:1254–1258
 26. Notarangelo LD (2010) Primary immunodeficiencies. *J Allergy Clin Immunol* 125:S182–S194
 27. Kazatchkine MD, Kaveri SV (2001) Immunomodulation of autoimmune and inflammatory diseases with intravenous immune globulin. *N Engl J Med* 345:747–755
 28. Tha-In T, Bayry J, Metselaar HJ, Kaveri SV, Kwekkeboom J (2008) Modulation of the cellular immune system by intravenous immunoglobulin. *Trends Immunol* 29:608–615
 29. Luke PP, Scantlebury VP, Jordan ML, Vivas CA, Hakala TR, Jain A, Somani A, Fedorek S, Randhawa P, Shapiro R (2001) Reversal of steroid- and anti-lymphocyte antibody-resistant rejection using intravenous immunoglobulin (IVIg) in renal transplant recipients. *Transplantation* 72:419–422
 30. Sokos DR, Berger M, Lazarus HM (2002) Intravenous immunoglobulin: appropriate indications and uses in hematopoietic stem cell transplantation. *Biol Blood Marrow Transplant* 8:117–130
 31. Casadei DH, del CRM, Opelz G, Golberg JC, Argento JA, Greco G, Guardia OE, Haas E, Raimondi EH (2001) A randomized and prospective study comparing treatment with high-dose intravenous immunoglobulin with monoclonal antibodies for rescue of kidney grafts with steroid-resistant rejection. *Transplantation* 71:53–58
 32. Newburger JW, Takahashi M, Burns JC, Beiser AS, Chung KJ, Duffy CE, Glode MP, Mason WH, Reddy V, Sanders SP et al (1986) The treatment of Kawasaki syndrome with intravenous gamma globulin. *N Engl J Med* 315:341–347
 33. Silverman ED, Somma C, Khan MM, Melmon KL, Engleman EG (1990) Abnormal T suppressor cell function in juvenile rheumatoid arthritis. *Arthritis Rheum* 33:205–211
 34. Kaneko Y, Nimmerjahn F, Ravetch JV (2006) Anti-inflammatory activity of immunoglobulin G resulting from Fc sialylation. *Science* 313:670–673
 35. Anthony RM, Nimmerjahn F, Ashline DJ, Reinhold VN, Paulson JC, Ravetch JV (2008) Recapitulation of IVIG anti-inflammatory activity with a recombinant IgG Fc. *Science* 320:373–376
 36. Anthony RM, Kobayashi T, Wermeling F, Ravetch JV (2011) Intravenous gammaglobulin suppresses inflammation through a novel T(H)2 pathway. *Nature* 475:110–113
 37. Kasermann F, Boerema DJ, Rueggsegger M, Hofmann A, Wymann S, Zuercher AW, Miescher S (2012) Analysis and functional consequences of increased Fab-sialylation of intravenous immunoglobulin (IVIg) after lectin fractionation. *PLoS One* 7:e37243
 38. Basta M, Dalakas MC (1994) High-dose intravenous immunoglobulin exerts its beneficial effect in patients with dermatomyositis by blocking endomysial deposition of activated complement fragments. *J Clin Invest* 94:1729–1735
 39. Basta M, Langlois PF, Marques M, Frank MM, Fries LF (1989) High-dose intravenous immunoglobulin modifies complement-mediated in vivo clearance. *Blood* 74:326–333
 40. Basta M, Kirshbom P, Frank MM, Fries LF (1989) Mechanism of therapeutic effect of

- high-dose intravenous immunoglobulin. Attenuation of acute, complement-dependent immune damage in a guinea pig model. *J Clin Invest* 84:1974–1981
41. Sato M, Kojima H, Koshikawa S (1986) Modification of immune complexes deposited in glomeruli in tissue sections treated with sulfonized gamma-globulin. *Clin Exp Immunol* 64:623–628
 42. Lin CY, Hsu HC, Chiang H (1989) Improvement of histological and immunological change in steroid and immunosuppressive drug-resistant lupus nephritis by high-dose intravenous gamma globulin. *Nephron* 53:303–310
 43. Leung DY, Cotran RS, Kurt-Jones E, Burns JC, Newburger JW, Pober JS (1989) Endothelial cell activation and high interleukin-1 secretion in the pathogenesis of acute Kawasaki disease. *Lancet* 2:1298–1302
 44. Aukrust P, Froland SS, Liabakk NB, Muller F, Nordoy I, Haug C, Espevik T (1994) Release of cytokines, soluble cytokine receptors, and interleukin-1 receptor antagonist after intravenous immunoglobulin administration in vivo. *Blood* 84:2136–2143
 45. Sharief MK, Ingram DA, Swash M, Thompson EJ (1999) I.v. immunoglobulin reduces circulating proinflammatory cytokines in Guillain-Barre syndrome. *Neurology* 52:1833–1838
 46. Xu C, Poirier B, Duong Van Huyen JP, Lucchiari N, Michel O, Chevalier J, Kaveri S (1998) Modulation of endothelial cell function by normal polyspecific human intravenous immunoglobulins: a possible mechanism of action in vascular diseases. *Am J Pathol* 153:1257–1266
 47. Leung DY (1996) Kawasaki syndrome: immunomodulatory benefit and potential toxin neutralization by intravenous immune globulin. *Clin Exp Immunol* 104(Suppl 1):49–54
 48. Ashkenazi S, Cleary TG, Lopez E, Pickering LK (1988) Anticytotoxin-neutralizing antibodies in immune globulin preparations: potential use in hemolytic-uremic syndrome. *J Pediatr* 113:1008–1014
 49. Leung DY, Kelly CP, Boguniewicz M, Pothoulakis C, LaMont JT, Flores A (1991) Treatment with intravenously administered gamma globulin of chronic relapsing colitis induced by *Clostridium difficile* toxin. *J Pediatr* 118:633–637
 50. Abe J, Jibiki T, Noma S, Nakajima T, Saito H, Terai M (2005) Gene expression profiling of the effect of high-dose intravenous Ig in patients with Kawasaki disease. *J Immunol* 174:5837–5845
 51. Rhoades CJ, Williams MA, Kelsey SM, Newland AC (2000) Monocyte-macrophage system as targets for immunomodulation by intravenous immunoglobulin. *Blood Rev* 14:14–30
 52. Kimberly RP, Salmon JE, Bussel JB, Crow MK, Hilgartner MW (1984) Modulation of mononuclear phagocyte function by intravenous gamma-globulin. *J Immunol* 132:745–750
 53. Salama A, Mueller-Eckhardt C, Kiefel V (1983) Effect of intravenous immunoglobulin in immune thrombocytopenia. *Lancet* 2:193–195
 54. Bussel JB, Kimberly RP, Inman RD, Schulman I, Cunningham-Rundles C, Cheung N, Smithwick EM, O'Malley J, Barandun S, Hilgartner MW (1983) Intravenous gamma-globulin treatment of chronic idiopathic thrombocytopenic purpura. *Blood* 62:480–486
 55. Debre M, Bonnet MC, Fridman WH, Carosella E, Philippe N, Reinert P, Vilmer E, Kaplan C, Teillaud JL, Griscelli C (1993) Infusion of Fc gamma fragments for treatment of children with acute immune thrombocytopenic purpura. *Lancet* 342:945–949
 56. Kaneko Y, Nimmerjahn F, Madaio MP, Ravetch JV (2006) Pathology and protection in nephrotoxic nephritis is determined by selective engagement of specific Fc receptors. *J Exp Med* 203:789–797
 57. van Mirre E, Teeling JL, van der Meer JW, Bleeker WK, Hack CE (2004) Monomeric IgG in intravenous Ig preparations is a functional antagonist of FcgammaRII and FcgammaRIIIb. *J Immunol* 173:332–339
 58. von Gunten S, Schaub A, Vogel M, Stadler BM, Miescher S, Simon HU (2006) Immunologic and functional evidence for anti-Siglec-9 autoantibodies in intravenous immunoglobulin preparations. *Blood* 108:4255–4259
 59. Chang J, Shi PA, Chiang EY, Frenette PS (2008) Intravenous immunoglobulins reverse acute vaso-occlusive crises in sickle cell mice through rapid inhibition of neutrophil adhesion. *Blood* 111:915–923
 60. Jarius S, Eichhorn P, Albert MH, Wagenpfeil S, Wick M, Belohradsky BH, Hohlfeld R, Jenne DE, Voltz R (2007) Intravenous immunoglobulins contain naturally occurring antibodies that mimic antineutrophil cytoplasmic antibodies and activate neutrophils in a TNFalpha-dependent and Fc-receptor-independent way. *Blood* 109:4376–4382

61. Kwak JY, Kwak FM, Ainbinder SW, Ruiz AM, Beer AE (1996) Elevated peripheral blood natural killer cells are effectively downregulated by immunoglobulin G infusion in women with recurrent spontaneous abortions. *Am J Reprod Immunol* 35:363–369
62. Daya S, Gunby J, Clark DA (1998) Intravenous immunoglobulin therapy for recurrent spontaneous abortion: a meta-analysis. *Am J Reprod Immunol* 39:69–76
63. Hutton B, Sharma R, Fergusson D, Tinmouth A, Hebert P, Jamieson J, Walker M (2007) Use of intravenous immunoglobulin for treatment of recurrent miscarriage: a systematic review. *BJOG* 114:134–142
64. Finberg RW, Newburger JW, Mikati MA, Heller AH, Burns JC (1992) Effect of high doses of intravenously administered immune globulin on natural killer cell activity in peripheral blood. *J Pediatr* 120:376–380
65. Tha-In T, Metselaar HJ, Tilanus HW, Groothuismink ZM, Kuipers EJ, de Man RA, Kwekkeboom J (2007) Intravenous immunoglobulins suppress T-cell priming by modulating the bidirectional interaction between dendritic cells and natural killer cells. *Blood* 110:3253–3262
66. Bayry J, Lacroix-Desmazes S, Carbonneil C, Misra N, Donkova V, Pashov A, Chevailler A, Mouthon L, Weill B, Bruneval P, Kazatchkine MD, Kaveri SV (2003) Inhibition of maturation and function of dendritic cells by intravenous immunoglobulin. *Blood* 101:758–765
67. Bayry J, Lacroix-Desmazes S, Delignat S, Mouthon L, Weill B, Kazatchkine MD, Kaveri SV (2003) Intravenous immunoglobulin abrogates dendritic cell differentiation induced by interferon-alpha present in serum from patients with systemic lupus erythematosus. *Arthritis Rheum* 48:3497–3502
68. Shioji K, Kishimoto C, Sasayama S (2001) Fc receptor-mediated inhibitory effect of immunoglobulin therapy on autoimmune giant cell myocarditis: concomitant suppression of the expression of dendritic cells. *Circ Res* 89:540–546
69. Siragam V, Crow AR, Brinc D, Song S, Freedman J, Lazarus AH (2006) Intravenous immunoglobulin ameliorates ITP via activating Fc gamma receptors on dendritic cells. *Nat Med* 12:688–692
70. Sultan Y, Kazatchkine MD, Maisonneuve P, Nydegger UE (1984) Anti-idiotypic suppression of autoantibodies to factor VIII (antihemophilic factor) by high-dose intravenous gammaglobulin. *Lancet* 2:765–768
71. Rossi F, Sultan Y, Kazatchkine MD (1988) Anti-idiotypes against autoantibodies and alloantibodies to VIII:C (anti-hemophilic factor) are present in therapeutic polyspecific normal immunoglobulins. *Clin Exp Immunol* 74:311–316
72. Rossi F, Jayne DR, Lockwood CM, Kazatchkine MD (1991) Anti-idiotypes against anti-neutrophil cytoplasmic antigen autoantibodies in normal human polyspecific IgG for therapeutic use and in the remission sera of patients with systemic vasculitis. *Clin Exp Immunol* 83:298–303
73. Abedi MR, Hammarstrom L, Broome U, Angelin B, Smith CI, Christensson B (1996) Reduction in serum levels of antimitochondrial (M2) antibodies following immunoglobulin therapy in severe combined immunodeficient (SCID) mice reconstituted with lymphocytes from patients with primary biliary cirrhosis (PBC). *Clin Exp Immunol* 105:266–273
74. Vassilev T, Yamamoto M, Aissaoui A, Bonnin E, Berrih-Aknin S, Kazatchkine MD, Kaveri SV (1999) Normal human immunoglobulin suppresses experimental myasthenia gravis in SCID mice. *Eur J Immunol* 29:2436–2442
75. de Grandmont MJ, Racine C, Roy A, Lemieux R, Neron S (2003) Intravenous immunoglobulins induce the in vitro differentiation of human B lymphocytes and the secretion of IgG. *Blood* 101:3065–3073
76. Bayry J, Fournier EM, Maddur MS, Vani J, Wootla B, Siberil S, Dimitrov JD, Lacroix-Desmazes S, Berdah M, Crabol Y, Oksenhendler E, Levy Y, Mouthon L, Sautes-Fridman C, Hermine O, Kaveri SV (2011) Intravenous immunoglobulin induces proliferation and immunoglobulin synthesis from B cells of patients with common variable immunodeficiency: a mechanism underlying the beneficial effect of IVIg in primary immunodeficiencies. *J Autoimmun* 36:9–15
77. Rigal D, Vermot-Desroches C, Heitz S, Bernaud J, Alfonsi F, Monier JC (1994) Effects of intravenous immunoglobulins (IVIg) on peripheral blood B, NK, and T cell subpopulations in women with recurrent spontaneous abortions: specific effects on LFA-1 and CD56 molecules. *Clin Immunol Immunopathol* 71:309–314
78. Tha-In T, Metselaar HJ, Tilanus HW, Boor PP, Mancham S, Kuipers EJ, de Man RA, Kwekkeboom J (2006) Superior immunomodulatory effects of intravenous immunoglobulins on human T-cells and dendritic cells: comparison to calcineurin inhibitors. *Transplantation* 81:1725–1734

79. Pashov A, Dubey C, Kaveri SV, Lectard B, Huang YM, Kazatchkine MD, Bellon B (1998) Normal immunoglobulin G protects against experimental allergic encephalomyelitis by inducing transferable T cell unresponsiveness to myelin basic protein. *Eur J Immunol* 28:1823–1831
80. Saoudi A, Hurez V, de Kozak Y, Kuhn J, Kaveri SV, Kazatchkine MD, Druet P, Bellon B (1993) Human immunoglobulin preparations for intravenous use prevent experimental autoimmune uveoretinitis. *Int Immunol* 5:1559–1567
81. Achiron A, Mor F, Margalit R, Cohen IR, Lider O, Miron S (2000) Suppression of experimental autoimmune encephalomyelitis by intravenously administered polyclonal immunoglobulins. *J Autoimmun* 15:323–330
82. Nicoletti A, Kaveri S, Caligiuri G, Bariety J, Hansson GK (1998) Immunoglobulin treatment reduces atherosclerosis in apo E knockout mice. *J Clin Invest* 102:910–918
83. Shirin H, Bruck R, Aeed H, Hershkoviz R, Lider O, Kenet G, Avni Y, Halpern Z (1997) Effects of intravenous immunoglobulins on T-cell mediated, concanavalin A-induced hepatitis in mice. *Liver* 17:275–280
84. Kessel A, Ammuri H, Peri R, Pavlotzky ER, Blank M, Shoenfeld Y, Toubi E (2007) Intravenous immunoglobulin therapy affects T regulatory cells by increasing their suppressive function. *J Immunol* 179:5571–5575
85. Ephrem A, Chamat S, Miquel C, Fisson S, Mouthon L, Caligiuri G, Delignat S, Elluru S, Bayry J, Lacroix-Desmazes S, Cohen JL, Salomon BL, Kazatchkine MD, Kaveri SV, Misra N (2008) Expansion of CD4+CD25+ regulatory T cells by intravenous immunoglobulin: a critical factor in controlling experimental autoimmune encephalomyelitis. *Blood* 111:715–722
86. Kohler G, Milstein C (1975) Continuous cultures of fused cells secreting antibody of predefined specificity. *Nature* 256:495–497
87. Klinman NR, Segal GP, Gerhard W, Braciale T, Levy R (1977) Obtaining homogeneous antibody of desired specificity from fragment cultures. In: Haber E, Krause RM (eds) *Antibodies in human diagnosis and therapy*. Raven, New York, pp 225–236
88. Miller RA, Maloney DG, Warnke R, Levy R (1982) Treatment of B-cell lymphoma with monoclonal anti-idiotypic antibody. *N Engl J Med* 306:517–522
89. Morrison SL, Johnson MJ, Herzenberg LA, Oi VT (1984) Chimeric human antibody molecules: mouse antigen-binding domains with human constant region domains. *Proc Natl Acad Sci U S A* 81:6851–6855
90. Boulianne GL, Hozumi N, Shulman MJ (1984) Production of functional chimaeric mouse/human antibody. *Nature* 312:643–646
91. den Broeder A, van de Putte L, Rau R, Schattenkirchner M, Van Riel P, Sander O, Binder C, Fenner H, Bankmann Y, Velagapudi R, Kempeni J, Kupper H (2002) A single dose, placebo controlled study of the fully human anti-tumor necrosis factor-alpha antibody adalimumab (D2E7) in patients with rheumatoid arthritis. *J Rheumatol* 29:2288–2298
92. Rau R (2002) Adalimumab (a fully human anti-tumour necrosis factor alpha monoclonal antibody) in the treatment of active rheumatoid arthritis: the initial results of five trials. *Ann Rheum Dis* 61(Suppl 2):ii70–ii73
93. Onrust SV, Lamb HM (1998) Infliximab: a review of its use in Crohn's disease and rheumatoid arthritis. *BioDrugs* 10:397–422
94. Cuchacovich M, Soto L, Edwardes M, Gutierrez M, Llanos C, Pacheco D, Sabugo F, Alamo M, Fuentealba C, Villanueva L, Gatica H, Schiattino I, Salazar L, Catalan D, Valenzuela O, Salazar-Onfray F, Aguillon JC (2006) Tumour necrosis factor (TNF)alpha-308 G/G promoter polymorphism and TNFalpha levels correlate with a better response to adalimumab in patients with rheumatoid arthritis. *Scand J Rheumatol* 35:435–440
95. Danese S, Sans M, Scaldaferrri F, Sgambato A, Rutella S, Cittadini A, Pique JM, Panes J, Katz JA, Gasbarrini A, Fiocchi C (2006) TNF-alpha blockade down-regulates the CD40/CD40L pathway in the mucosal microcirculation: a novel anti-inflammatory mechanism of infliximab in Crohn's disease. *J Immunol* 176:2617–2624
96. Kirman I, Whelan RL, Nielsen OH (2004) Infliximab: mechanism of action beyond TNF-alpha neutralization in inflammatory bowel disease. *Eur J Gastroenterol Hepatol* 16:639–641
97. Ames SA, Gleeson CD, Kirkpatrick P (2004) Omalizumab. *Nat Rev Drug Discov* 3:199–200
98. Bang LM, Plosker GL (2004) Spotlight on omalizumab in allergic asthma. *BioDrugs* 18:415–418
99. Hennemann A (2004) Omalizumab. A monoclonal antibody against IgE. *Med Monatsschr Pharm* 27:404–407
100. Holgate ST, Chuchalin AG, Hebert J, Lotvall J, Persson GB, Chung KF, Bousquet J,

- Kerstjens HA, Fox H, Thirlwell J, Cioppa GD (2004) Efficacy and safety of a recombinant anti-immunoglobulin E antibody (omalizumab) in severe allergic asthma. *Clin Exp Allergy* 34:632–638
101. Smolen JS, Kay J, Doyle MK, Landewe R, Matteson EL, Wollenhaupt J, Gaylis N, Murphy FT, Neal JS, Zhou Y, Visvanathan S, Hsia EC, Rahman MU (2009) Golimumab in patients with active rheumatoid arthritis after treatment with tumour necrosis factor alpha inhibitors (GO-AFTER study): a multicentre, randomised, double-blind, placebo-controlled, phase III trial. *Lancet* 374: 210–221
 102. Oldfield V, Plosker GL (2009) Golimumab: in the treatment of rheumatoid arthritis, psoriatic arthritis, and ankylosing spondylitis. *BioDrugs* 23:125–135
 103. Kavanaugh A, McInnes I, Mease P, Krueger GG, Gladman D, Gomez-Reino J, Papp K, Zrubek J, Mudivarthi S, Mack M, Visvanathan S, Beutler A (2009) Golimumab, a new human tumor necrosis factor alpha antibody, administered every four weeks as a subcutaneous injection in psoriatic arthritis: twenty-four-week efficacy and safety results of a randomized, placebo-controlled study. *Arthritis Rheum* 60:976–986
 104. Faulds D, Sorkin EM (1994) Abciximab (c7E3 Fab). A review of its pharmacology and therapeutic potential in ischaemic heart disease. *Drugs* 48:583–598
 105. Tchong JE, Kandzari DE, Grines CL, Cox DA, Effron MB, Garcia E, Griffin JJ, Guagliumi G, Stuckey T, Turco M, Fahy M, Lansky AJ, Mehran R, Stone GW (2003) Benefits and risks of Abciximab use in primary angioplasty for acute myocardial infarction: the controlled Abciximab and device investigation to lower late angioplasty complications (CADILLAC) trial. *Circulation* 108: 1316–1323
 106. Schror K, Weber AA (2003) Comparative pharmacology of GP IIb/IIIa antagonists. *J Thromb Thrombolysis* 15:71–80
 107. Weber AA, Schror K (2001) Differential inhibition of adenosine diphosphate- versus thrombin receptor-activating peptide-stimulated platelet fibrinogen binding by abciximab due to different glycoprotein IIb/IIIa activation kinetics. *Blood* 98:1619–1621
 108. Walsh GM (2009) Canakinumab for the treatment of cryopyrin-associated periodic syndromes. *Drugs Today (Barc)* 45:731–735
 109. Lachmann HJ, Kone-Paut I, Kuemmerle-Deschner JB, Leslie KS, Hachulla E, Quartier P, Gitton X, Widmer A, Patel N, Hawkins PN (2009) Use of canakinumab in the cryopyrin-associated periodic syndrome. *N Engl J Med* 360:2416–2425
 110. Church LD, McDermott MF (2009) Canakinumab, a fully-human mAb against IL-1beta for the potential treatment of inflammatory disorders. *Curr Opin Mol Ther* 11:81–89
 111. Baumgart DC, Sandborn WJ (2007) Inflammatory bowel disease: clinical aspects and established and evolving therapies. *Lancet* 369:1641–1657
 112. Stefanelli T, Malesci A, Repici A, Vetrano S, Danese S (2008) New insights into inflammatory bowel disease pathophysiology: paving the way for novel therapeutic targets. *Curr Drug Targets* 9:413–418
 113. Lalande JD, Behr MA (2010) Mycobacteria in Crohn's disease: how innate immune deficiency may result in chronic inflammation. *Expert Rev Clin Immunol* 6:633–641
 114. Brynskov J, Foegh P, Pedersen G, Ellervik C, Kirkegaard T, Bingham A, Saermark T (2002) Tumour necrosis factor alpha converting enzyme (TACE) activity in the colonic mucosa of patients with inflammatory bowel disease. *Gut* 51:37–43
 115. Baker DE (2008) Certolizumab pegol: a polyethylene glycolated Fab' fragment of humanized anti-tumor necrosis factor alpha monoclonal antibody for the treatment of Crohn's disease. *Rev Gastroenterol Disord* 8:240–253
 116. Patel VK, Ghosh S (2008) Certolizumab pegol in Crohn's disease. *Drugs Today (Barc)* 44:837–844
 117. Sandborn WJ (2008) Certolizumab pegol for moderate-to-severe Crohn's disease. *Gastroenterol Hepatol (NY)* 4:467–468
 118. Danese S, Mocciano F, Guidi L, Scribano ML, Comberlato M, Annese V, Colombo E, Stefanelli T, Marzo M, Vangeli M, Pulitano R, Manca A, Armuzzi A, Malesci A, Prantera C, Cottone M (2008) Successful induction of clinical response and remission with certolizumab pegol in Crohn's disease patients refractory or intolerant to infliximab: a real-life multicenter experience of compassionate use. *Inflamm Bowel Dis* 14:1168–1170
 119. Schreiber S (2005) The complicated path to true causes of disease: role of nuclear factor kappaB in inflammatory bowel disease. *Gut* 54:444–445
 120. Rosenfeld PJ, Rich RM, Lalwani GA (2006) Ranibizumab: phase III clinical trial results. *Ophthalmol Clin North Am* 19:361–372
 121. Rosenfeld PJ, Brown DM, Heier JS, Boyer DS, Kaiser PK, Chung CY, Kim RY (2006) Ranibizumab for neovascular age-related

- macular degeneration. *N Engl J Med* 355:1419–1431
122. Narayanan R, Kuppermann BD, Jones C, Kirkpatrick P (2006) Ranibizumab. *Nat Rev Drug Discov* 5:815–816
 123. Dugel PU (2006) Ranibizumab treatment of patients with ocular diseases. *Int Ophthalmol Clin* 46:131–140
 124. Subramanian ML, Abedi G, Ness S, Ahmed E, Fenberg M, Daly MK, Houranah A, Feinberg EB (2010) Bevacizumab vs. ranibizumab for age-related macular degeneration: 1-year outcomes of a prospective, double-masked randomised clinical trial. *Eye (Lond)* 24:1708–1715
 125. Wootla B, Eriguchi M, Rodriguez M (2012) Is multiple sclerosis an autoimmune disease? *Autoimmune Dis* 2012:969657
 126. Bartt RE (2006) Multiple sclerosis, natalizumab therapy, and progressive multifocal leukoencephalopathy. *Curr Opin Neurol* 19:341–349
 127. Polman CH, O'Connor PW, Havrdova E, Hutchinson M, Kappos L, Miller DH, Phillips JT, Lublin FD, Giovannoni G, Wajgt A, Toal M, Lynn F, Panzara MA, Sandrock AW (2006) A randomized, placebo-controlled trial of natalizumab for relapsing multiple sclerosis. *N Engl J Med* 354:899–910
 128. Ramos-Cejudo J, Oreja-Guevara C, Stark Aroeira L, Rodriguez de Antonio L, Chamorro B, Diez-Tejedor E (2011) Treatment with natalizumab in relapsing-remitting multiple sclerosis induces changes in inflammatory mechanism. *J Clin Immunol* 31:623–631
 129. Rice GP, Hartung HP, Calabresi PA (2005) Anti-alpha4 integrin therapy for multiple sclerosis: mechanisms and rationale. *Neurology* 64:1336–1342
 130. Linda H, von Heijne A, Major EO, Ryschkewitsch C, Berg J, Olsson T, Martin C (2009) Progressive multifocal leukoencephalopathy after natalizumab monotherapy. *N Engl J Med* 361:1081–1087
 131. Bloomgren G, Richman S, Hotermans C, Subramanyam M, Goelz S, Natarajan A, Lee S, Plavina T, Scanlon JV, Sandrock A, Bozic C (2012) Risk of natalizumab-associated progressive multifocal leukoencephalopathy. *N Engl J Med* 366:1870–1880
 132. Hillmen P, Muus P, Duhrsen U, Risitano AM, Schubert J, Luzzatto L, Schrezenmeier H, Szer J, Brodsky RA, Hill A, Socie G, Bessler M, Rollins SA, Bell L, Rother RP, Young NS (2007) Effect of the complement inhibitor eculizumab on thromboembolism in patients with paroxysmal nocturnal hemoglobinuria. *Blood* 110:4123–4128
 133. Parker CJ, Kar S, Kirkpatrick P (2007) Eculizumab. *Nat Rev Drug Discov* 6:515–516
 134. Rother RP, Rollins SA, Mojcik CF, Brodsky RA, Bell L (2007) Discovery and development of the complement inhibitor eculizumab for the treatment of paroxysmal nocturnal hemoglobinuria. *Nat Biotechnol* 25:1256–1264
 135. Zareba KM (2007) Eculizumab: a novel therapy for paroxysmal nocturnal hemoglobinuria. *Drugs Today (Barc)* 43:539–546
 136. Hillmen P, Young NS, Schubert J, Brodsky RA, Socie G, Muus P, Roth A, Szer J, Elebute MO, Nakamura R, Browne P, Risitano AM, Hill A, Schrezenmeier H, Fu CL, Maciejewski J, Rollins SA, Mojcik CF, Rother RP, Luzzatto L (2006) The complement inhibitor eculizumab in paroxysmal nocturnal hemoglobinuria. *N Engl J Med* 355:1233–1243
 137. Weinberg JM, Saini R, Tutrone WD (2002) Biologic therapy for psoriasis—the first wave: infliximab, etanercept, efalizumab, and alefacept. *J Drugs Dermatol* 1:303–310
 138. Dredrick RL, Walicke P, Garovoy M (2002) Anti-adhesion antibodies efalizumab, a humanized anti-CD11a monoclonal antibody. *Transpl Immunol* 9:181–186
 139. News (2002) Efalizumab. Anti-CD11a monoclonal antibody—Genentech/Xoma, HU 1124, hu1124, xanelim. *Drugs R&D* 3:40–43
 140. Berger JR, Houff SA, Major EO (2009) Monoclonal antibodies and progressive multifocal leukoencephalopathy. *MAbs* 1:583–589
 141. Agarwal SK (2011) Biologic agents in rheumatoid arthritis: an update for managed care professionals. *J Manag Care Pharm* 17:S14–S18
 142. Nakou M, Katsikas G, Sidiropoulos P, Bertsias G, Papadimitraki E, Raptopoulou A, Koutala H, Papadaki HA, Kritikos H, Boumpas DT (2009) Rituximab therapy reduces activated B cells in both the peripheral blood and bone marrow of patients with rheumatoid arthritis: depletion of memory B cells correlates with clinical response. *Arthritis Res Ther* 11:R131
 143. Kishimoto T (2006) Interleukin-6: discovery of a pleiotropic cytokine. *Arthritis Res Ther* 8(Suppl 2):S2
 144. Madhok R, Crilly A, Watson J, Capell HA (1993) Serum interleukin 6 levels in rheumatoid arthritis: correlations with clinical and laboratory indices of disease activity. *Ann Rheum Dis* 52:232–234
 145. Yoshizaki K, Nishimoto N, Mihara M, Kishimoto T (1998) Therapy of rheumatoid arthritis by blocking IL-6 signal transduction

- with a humanized anti-IL-6 receptor antibody. *Springer Semin Immunopathol* 20:247–259
146. Dennis GJ (2012) Belimumab: a BLyS-specific inhibitor for the treatment of systemic lupus erythematosus. *Clin Pharmacol Ther* 91:143–149
 147. Furie R, Petri M, Zamani O, Cervera R, Wallace DJ, Tegzova D, Sanchez-Guerrero J, Schwarting A, Merrill JT, Chatham WW, Stohl W, Ginzler EM, Hough DR, Zhong ZJ, Freimuth W, van Vollenhoven RF (2011) A phase III, randomized, placebo-controlled study of belimumab, a monoclonal antibody that inhibits B lymphocyte stimulator, in patients with systemic lupus erythematosus. *Arthritis Rheum* 63:3918–3930
 148. Sanz I, Yasothan U, Kirkpatrick P (2011) Belimumab. *Nat Rev Drug Discov* 10:335–336
 149. Macris MP, Frazier OH, Lammermeier D, Radovancevic B, Duncan JM (1989) Clinical experience with Muromonab-CD3 monoclonal antibody (OKT3) in heart transplantation. *J Heart Transplant* 8:281–287
 150. Todd PA, Brogden RN (1989) Muromonab CD3. A review of its pharmacology and therapeutic potential. *Drugs* 37:871–899
 151. Emmons C, Hunsicker LG (1987) Muromonab-CD3 (Orthoclone OKT3): the first monoclonal antibody approved for therapeutic use. *Iowa Med* 77:78–82
 152. Midtvedt K, Fauchald P, Lien B, Hartmann A, Albrechtsen D, Bjerkely BL, Leivestad T, Brekke IB (2003) Individualized T cell monitored administration of ATG versus OKT3 in steroid-resistant kidney graft rejection. *Clin Transplant* 17:69–74
 153. Kovarik J, Breidenbach T, Gerbeau C, Korn A, Schmidt AG, Nashan B (1998) Disposition and immunodynamics of basiliximab in liver allograft recipients. *Clin Pharmacol Ther* 64:66–72
 154. News (1998) Basiliximab approved for use in renal transplant patients. *Am J Health Syst Pharm* 55:1444–1445
 155. Vincenti F, Nashan B, Light S (1998) Daclizumab: outcome of phase III trials and mechanism of action. Double Therapy and the Triple Therapy Study Groups. *Transplant Proc* 30:2155–2158
 156. Abramowicz D (1998) Daclizumab to prevent acute rejection in renal transplantation. *N Engl J Med* 338:1700–1701
 157. Vincenti F, Kirkman R, Light S, Bumgardner G, Pescovitz M, Halloran P, Neylan J, Wilkinson A, Ekberg H, Gaston R, Backman L, Burdick J (1998) Interleukin-2-receptor blockade with daclizumab to prevent acute rejection in renal transplantation. Daclizumab Triple Therapy Study Group. *N Engl J Med* 338:161–165
 158. Treish IM (2000) Targeting leukemia cells with gemtuzumab ozogamicin. *Cancer Pract* 8:254–257
 159. Niculescu-Duvaz I (2000) Technology evaluation: gemtuzumab ozogamicin. Celltech Group. *Curr Opin Mol Ther* 2:691–696
 160. de Vetten MP, Jansen JH, van der Reijden BA, Berger MS, Zijlmans JM, Lowenberg B (2000) Molecular remission of Philadelphia/bcr-abl-positive acute myeloid leukaemia after treatment with anti-CD33 calicheamicin conjugate (gemtuzumab ozogamicin, CMA-676). *Br J Haematol* 111:277–279
 161. Naito K, Takeshita A, Shigeno K, Nakamura S, Fujisawa S, Shinjo K, Yoshida H, Ohnishi K, Mori M, Terakawa S, Ohno R (2000) Calicheamicin-conjugated humanized anti-CD33 monoclonal antibody (gemtuzumab zogamicin, CMA-676) shows cytotoxic effect on CD33-positive leukemia cell lines, but is inactive on P-glycoprotein-expressing sublines. *Leukemia* 14:1436–1443
 162. News (2000) Gemtuzumab for relapsed acute myeloid leukemia. *Med Lett Drugs Ther* 42:67–68
 163. Communication (1998) Molecule of the month: trastuzumab. *Drug News Perspect* 11:305
 164. Communication (1998) Trastuzumab and capecitabine for metastatic breast cancer. *Med Lett Drugs Ther* 40:106–108
 165. Mir O, Berveiller P, Pons G (2007) Trastuzumab—mechanism of action and use. *N Engl J Med* 357:1664–1665, author reply 1665–1666
 166. Karamouzis MV, Konstantinopoulos PA, Papavassiliou AG (2007) Trastuzumab—mechanism of action and use. *N Engl J Med* 357:1664, author reply 1665–1666
 167. Hudis CA (2007) Trastuzumab—mechanism of action and use in clinical practice. *N Engl J Med* 357:39–51
 168. Valabrega G, Montemurro F, Aglietta M (2007) Trastuzumab: mechanism of action, resistance and future perspectives in HER2-overexpressing breast cancer. *Ann Oncol* 18:977–984
 169. Sliwkowski MX, Lofgren JA, Lewis GD, Hotelling TE, Fendly BM, Fox JA (1999) Nonclinical studies addressing the mechanism of action of trastuzumab (Herceptin). *Semin Oncol* 26:60–70
 170. Slamon DJ, Godolphin W, Jones LA, Holt JA, Wong SG, Keith DE, Levin WJ, Stuart SG, Udove J, Ullrich A et al (1989) Studies of the

- HER-2/neu proto-oncogene in human breast and ovarian cancer. *Science* 244:707–712
171. Ferrajoli A, O'Brien S, Keating MJ (2001) Alemtuzumab: a novel monoclonal antibody. *Expert Opin Biol Ther* 1:1059–1065
 172. Smith JA (2001) Alemtuzumab: a new option for refractory chronic lymphocytic leukemia? *Cancer Pract* 9:211–213
 173. Castillo J, Milani C, Mendez-Allwood D (2009) Ofatumumab, a second-generation anti-CD20 monoclonal antibody, for the treatment of lymphoproliferative and autoimmune disorders. *Expert Opin Investig Drugs* 18:491–500
 174. Traynor K (2009) Ofatumumab approved for advanced CLL. *Am J Health Syst Pharm* 66:2062
 175. Zhang B (2009) Ofatumumab. *MAbs* 1: 326–331
 176. Du J, Yang H, Guo Y, Ding J (2009) Structure of the Fab fragment of therapeutic antibody Ofatumumab provides insights into the recognition mechanism with CD20. *Mol Immunol* 46:2419–2423
 177. Mone AP, Cheney C, Banks AL, Tridandapani S, Mehter N, Guster S, Lin T, Eisenbeis CF, Young DC, Byrd JC (2006) Alemtuzumab induces caspase-independent cell death in human chronic lymphocytic leukemia cells through a lipid raft-dependent mechanism. *Leukemia* 20:272–279
 178. Herbst RS (2004) Review of epidermal growth factor receptor biology. *Int J Radiat Oncol Biol Phys* 59:21–26
 179. Chu E (2006) Panitumumab: a new anti-EGFR antibody for the treatment of advanced colorectal cancer. *Clin Colorectal Cancer* 6:13
 180. Hoy SM, Wagstaff AJ (2006) Panitumumab: in the treatment of metastatic colorectal cancer. *Drugs* 66:2005–2014, discussion 2015–2006
 181. Saltz L, Easley C, Kirkpatrick P (2006) Panitumumab. *Nat Rev Drug Discov* 5: 987–988
 182. Ferrara N, Hillan KJ, Gerber HP, Novotny W (2004) Discovery and development of bevacizumab, an anti-VEGF antibody for treating cancer. *Nat Rev Drug Discov* 3:391–400
 183. Willett CG, Boucher Y, di Tomaso E, Duda DG, Munn LL, Tong RT, Chung DC, Sahani DV, Kalva SP, Kozin SV, Mino M, Cohen KS, Scadden DT, Hartford AC, Fischman AJ, Clark JW, Ryan DP, Zhu AX, Blaszkowsky LS, Chen HX, Shellito PC, Lauwers GY, Jain RK (2004) Direct evidence that the VEGF-specific antibody bevacizumab has antivascular effects in human rectal cancer. *Nat Med* 10:145–147
 184. Fanale MA, Forero-Torres A, Rosenblatt JD, Advani RH, Franklin AR, Kennedy DA, Han TH, Sievers EL, Bartlett NL (2012) A phase I weekly dosing study of brentuximab vedotin in patients with relapsed/refractory CD30-positive hematologic malignancies. *Clin Cancer Res* 18:248–255
 185. Foyil KV, Bartlett NL (2011) Brentuximab vedotin for the treatment of CD30+ lymphomas. *Immunotherapy* 3:475–485
 186. Maloney DG, Grillo-Lopez AJ, White CA, Bodkin D, Schilder RJ, Neidhart JA, Janakiraman N, Foon KA, Liles TM, Dallaire BK, Wey K, Royston I, Davis T, Levy R (1997) IDEC-C2B8 (Rituximab) anti-CD20 monoclonal antibody therapy in patients with relapsed low-grade non-Hodgkin's lymphoma. *Blood* 90:2188–2195
 187. Anderson DR, Grillo-Lopez A, Varns C, Chambers KS, Hanna N (1997) Targeted anti-cancer therapy using rituximab, a chimeric anti-CD20 antibody (IDEC-C2B8) in the treatment of non-Hodgkin's B-cell lymphoma. *Biochem Soc Trans* 25:705–708
 188. Gibson AD (2002) Updated results of a Phase III trial comparing ibritumomab tiuxetan with rituximab in previously treated patients with non-Hodgkin's lymphoma. *Clin Lymphoma* 3:87–89
 189. Wiseman GA, Gordon LI, Multani PS, Witzig TE, Spies S, Bartlett NL, Schilder RJ, Murray JL, Saleh M, Allen RS, Grillo-Lopez AJ, White CA (2002) Ibritumomab tiuxetan radioimmunotherapy for patients with relapsed or refractory non-Hodgkin lymphoma and mild thrombocytopenia: a phase II multicenter trial. *Blood* 99:4336–4342
 190. Zelenetz AD (2003) A clinical and scientific overview of tositumomab and iodine I 131 tositumomab. *Semin Oncol* 30:22–30
 191. Press OW, Unger JM, Brazier RM, Maloney DG, Miller TP, LeBlanc M, Gaynor ER, Rivkin SE, Fisher RI (2003) A phase 2 trial of CHOP chemotherapy followed by tositumomab/iodine I 131 tositumomab for previously untreated follicular non-Hodgkin lymphoma: Southwest Oncology Group Protocol S9911. *Blood* 102:1606–1612
 192. News (2003) Iodine-131 Tositumomab: (131)I-anti-B1 antibody, (131)I-tositumomab, anti-CD20 murine monoclonal antibody-I-131, B1, Bexxar, (131)I-anti-B1 antibody, iodine-131 tositumomab, iodine-131 anti-B1 antibody, tositumomab. *BioDrugs* 17:290–295
 193. News (2003) Iodine-131 tositumomab (bexxar) for treatment of lymphoma. *Med Lett Drugs Ther* 45:86–87

194. Hersh EM, O'Day SJ, Powderly J, Khan KD, Pavlick AC, Cranmer LD, Samlowski WE, Nichol GM, Yellin MJ, Weber JS (2011) A phase II multicenter study of ipilimumab with or without dacarbazine in chemotherapy-naïve patients with advanced melanoma. *Invest New Drugs* 29:489–498
195. Robert C, Thomas L, Bondarenko I, O'Day S, JW MD, Garbe C, Lebbe C, Baurain JF, Testori A, Grob JJ, Davidson N, Richards J, Maio M, Hauschild A, Miller WH Jr, Gascon P, Lotem M, Harmankaya K, Ibrahim R, Francis S, Chen TT, Humphrey R, Hoos A, Wolchok JD (2011) Ipilimumab plus dacarbazine for previously untreated metastatic melanoma. *N Engl J Med* 364:2517–2526
196. Robert C, Ghiringhelli F (2009) What is the role of cytotoxic T lymphocyte-associated antigen 4 blockade in patients with metastatic melanoma? *Oncologist* 14:848–861
197. Baron R, Ferrari S, Russell RG (2011) Denosumab and bisphosphonates: different mechanisms of action and effects. *Bone* 48: 677–692
198. Iqbal J, Sun L, Zaidi M (2010) Denosumab for the treatment of osteoporosis. *Curr Osteoporos Rep* 8:163–167
199. Lewiecki EM (2010) Denosumab—an emerging treatment for postmenopausal osteoporosis. *Expert Opin Biol Ther* 10:467–476
200. Rizzoli R, Yasothan U, Kirkpatrick P (2010) Denosumab. *Nat Rev Drug Discov* 9: 591–592
201. McClung MR, Lewiecki EM, Cohen SB, Bolognese MA, Woodson GC, Moffett AH, Peacock M, Miller PD, Lederman SN, Chesnut CH, Lain D, Kivitz AJ, Holloway DL, Zhang C, Peterson MC, Bekker PJ (2006) Denosumab in postmenopausal women with low bone mineral density. *N Engl J Med* 354:821–831
202. Lei S, Shiyong Y (2012) Efficacy and safety of denosumab versus zoledronic acid in patients with bone metastases: a systematic review and meta-analysis. *Am J Clin Oncol* 2012 Oct 8. [Epub ahead of print]
203. Guideline P (1998) Prevention of respiratory syncytial virus infections: indications for the use of palivizumab and update on the use of RSV-IGIV. American Academy of Pediatrics Committee on Infectious Diseases and Committee of Fetus and Newborn. *Pediatrics* 102:1211–1216
204. Trial C (1998) Palivizumab, a humanized respiratory syncytial virus monoclonal antibody, reduces hospitalization from respiratory syncytial virus infection in high-risk infants. The IMPact-RSV Study Group. *Pediatrics* 102:531–537
205. Shadman KA, Wald ER (2011) A review of palivizumab and emerging therapies for respiratory syncytial virus. *Expert Opin Biol Ther* 11:1455–1467
206. Warrington AE, Asakura K, Bieber AJ, Ciric B, Van Keulen V, Kaveri SV, Kyle RA, Pease LR, Rodriguez M (2000) Human monoclonal antibodies reactive to oligodendrocytes promote remyelination in a model of multiple sclerosis. *Proc Natl Acad Sci U S A* 97: 6820–6825
207. Mitsunaga Y, Ciric B, Van Keulen V, Warrington AE, Paz Soldan M, Bieber AJ, Rodriguez M, Pease LR (2002) Direct evidence that a human antibody derived from patient serum can promote myelin repair in a mouse model of chronic-progressive demyelinating disease. *FASEB J* 16:1325–1327
208. Warrington AE, Bieber AJ, Ciric B, Pease LR, Van Keulen V, Rodriguez M (2007) A recombinant human IgM promotes myelin repair after a single, very low dose. *J Neurosci Res* 85:967–976
209. Warrington AE, Bieber AJ, Van Keulen V, Ciric B, Pease LR, Rodriguez M (2004) Neuron-binding human monoclonal antibodies support central nervous system neurite extension. *J Neuropathol Exp Neurol* 63: 461–473
210. Van Keulen VP, Ciric B, Radhakrishnan S, Heckman KL, Mitsunaga Y, Iijima K, Kita H, Rodriguez M, Pease LR (2006) Immunomodulation using the recombinant monoclonal human B7-DC cross-linking antibody rHIgM12. *Clin Exp Immunol* 143: 314–321
211. Xu X, Warrington AE, Wright BR, Bieber AJ, Van Keulen V, Pease LR, Rodriguez M (2011) A human IgM signals axon outgrowth: coupling lipid raft to microtubules. *J Neurochem* 119:100–112
212. Denic A, Macura SI, Warrington AE, Pirko I, Grossardt BR, Pease LR, Rodriguez M (2011) A single dose of neuron-binding human monoclonal antibody improves spontaneous activity in a murine model of demyelination. *PLoS One* 6:e26001
213. Watzlawik J, Holicky E, Edberg DD, Marks DL, Warrington AE, Wright BR, Pagano RE, Rodriguez M (2010) Human remyelination promoting antibody inhibits apoptotic signaling and differentiation through Lyn kinase in primary rat oligodendrocytes. *Glia* 58:1782–1793
214. Wright BR, Warrington AE, Edberg DD, Rodriguez M (2009) Cellular mechanisms of

- central nervous system repair by natural auto-reactive monoclonal antibodies. *Arch Neurol* 66:1456–1459
215. Reichert JM, Rosensweig CJ, Faden LB, Dewitz MC (2005) Monoclonal antibody successes in the clinic. *Nat Biotechnol* 23:1073–1078
 216. Rieben R, Roos A, Muizert Y, Tinguely C, Gerritsen AF, Daha MR (1999) Immunoglobulin M-enriched human intravenous immunoglobulin prevents complement activation in vitro and in vivo in a rat model of acute inflammation. *Blood* 93:942–951
 217. Walpen AJ, Laumonier T, Aebi C, Mohacsi PJ, Rieben R (2004) Immunoglobulin M-enriched intravenous immunoglobulin inhibits classical pathway complement activation, but not bactericidal activity of human serum. *Xenotransplantation* 11:141–148
 218. Stehr SN, Knels L, Weissflog C, Schober J, Haufe D, Lupp A, Koch T, Heller AR (2008) Effects of IGM-enriched solution on polymorphonuclear neutrophil function, bacterial clearance, and lung histology in endotoxemia. *Shock* 29:167–172
 219. Bieber AJ, Warrington A, Asakura K, Ciric B, Kaveri SV, Pease LR, Rodriguez M (2002) Human antibodies accelerate the rate of remyelination following lysolecithin-induced demyelination in mice. *Glia* 37:241–249
 220. Hurez V, Kazatchkine MD, Vassilev T, Ramanathan S, Pashov A, Basuyaux B, de Kozak Y, Bellon B, Kaveri SV (1997) Pooled normal human polyspecific IgM contains neutralizing anti-idiotypes to IgG autoantibodies of autoimmune patients and protects from experimental autoimmune disease. *Blood* 90:4004–4013
 221. Varambally S, Bar-Dayán Y, Bayry J, Lacroix-Desmazes S, Horn M, Sorel M, Bar-Dayán Y, Ruberti G, Kazatchkine MD, Kaveri SV (2004) Natural human polyreactive IgM induce apoptosis of lymphoid cell lines and human peripheral blood mononuclear cells. *Int Immunol* 16:517–524
 222. Vassilev T, Mihaylova N, Voynova E, Nikolova M, Kazatchkine M, Kaveri S (2006) IgM-enriched human intravenous immunoglobulin suppresses T lymphocyte functions in vitro and delays the activation of T lymphocytes in hu-SCID mice. *Clin Exp Immunol* 145:108–115
 223. Bregenholt S, Jensen A, Lantto J, Hyldig S, Haurum JS (2006) Recombinant human polyclonal antibodies: a new class of therapeutic antibodies against viral infections. *Curr Pharm Des* 12:2007–2015
 224. Frandsen TP, Naested H, Rasmussen SK, Hauptig P, Wiberg FC, Rasmussen LK, Jensen AM, Persson P, Wiken M, Engstrom A, Jiang Y, Thorpe SJ, Forberg C, Tolstrup AB (2011) Consistent manufacturing and quality control of a highly complex recombinant polyclonal antibody product for human therapeutic use. *Biotechnol Bioeng* 108:2171–2181
 225. Koefoed K, Steinaa L, Soderberg JN, Kjaer I, Jacobsen HJ, Meijer PJ, Haurum JS, Jensen A, Kragh M, Andersen PS, Pedersen MW (2011) Rational identification of an optimal antibody mixture for targeting the epidermal growth factor receptor. *MAbs* 3:584–595

Production of Human Monoclonal Antibodies by the Epstein–Barr Virus Method

Michael Steinitz

Abstract

Epstein–Barr virus (EBV) is a herpes virus which in vitro efficiently immortalizes nearly all human B lymphocytes. The lymphoblastoid diploid cell lines (LCL's) thus generated preserve the characteristics of the cells initially infected by the virus: the cells produce and secrete immunoglobulins and also express these molecules on their surface. A selection of specific antibody-producing cells (i.e., antigen-committed cells) before EBV-infection or when LCL's have already been established, enables isolation of monoclonal cell lines that secrete specific antibodies. If selection of antigen-committed cells is not feasible, secretion of specific antibodies by cloned LCL's in limiting dilution cultures enables isolation of the desired cell lines. The method allows the production of human IgM, IgG, IgA, and IgE monoclonal antibodies from any individual. Monoclonal antibodies produced by the EBV method resemble the antibody repertoire of the donor of the lymphocytes. Human monoclonal antibodies are promising reagents for passive immunization.

Key words Epstein–Barr virus, Immortalization, Diploid, Lymphoblastoid cell line, Passive immunization, Antibody repertoire/

1 Introduction

In the early 1970s, when monoclonal antibodies were still an unknown entity, I started my post doctoral studies in George Klein's laboratory in Stockholm, Sweden, a worldwide known Epstein–Barr virus (EBV) research center. The exciting finding that EBV efficiently immortalizes human B-cells [1] led George Klein to suggest that the virus might be used to establish cell lines which in vitro produce human-specific antibodies. In a series of studies we generated for the first time human monoclonal antibodies, with prospects for future clinical applications [2].

EBV, a member of the herpes virus family is one of the most common viruses found in humans [3]. Most of the Western population is infected with the virus, each individual maintaining a

life-long active immune response against the virus and against the cells infected by it.

In vivo, EBV infects B cells expressing on their surface the CD21 EBV receptor [4]. Under some conditions even other cells, devoid of the receptor, are infected by the virus. The initial lytic virus infection of B cells is normally followed by an EBV latency that persists within CD27 positive memory B lymphocytes for life [5].

In vitro, resting human B lymphocytes infected with EBV show typical viral latency, reflected by the expression of a limited number of viral proteins and two types of non-translated RNA molecules. The virus-induced-molecules transform the B cells into immortalized diploid cells that usually do not release virus particles. EBV efficiently infects the majority of human B lymphocytes, including IgM, IgG, IgA, and IgE cells [6–10]. The immortalized cells, which grow rapidly as a suspension in standard cell culture media supplemented with fetal calf serum or in serum-free medium, usually reach a density of about 10^6 cells/ml. They maintain the characteristics of the initially infected B lymphocytes, including expression and secretion of immunoglobulins. The cells can be cloned with the support of a feeder layer. Depending on each specific cell line, the tissue culture medium derived from cells at saturation contains 0.5–10 μ g immunoglobulin/ml. Because of their human origin, these cells cannot be grown as peritoneal ascites in normal mice.

EBV can be used to make specific antibody-producing cell lines, provided that the virus-targeted lymphocytes are derived from a donor who has been exposed to the corresponding antigen. This limitation might be overcome if antigen-specific sensitization in vitro systems were developed (*see* Chapter 15 in this volume by Tomimatsu and Shirahata). Somatic mutations and isotype switching take place during in vitro growth of the LCL's [11–13]. The enzymatic activity of activation-induced cytidine deaminase (AID) plays a major role in inducing these changes in the immunoglobulin genes [14]. In contrast to the corresponding process in vivo, the ongoing somatic mutations during in vitro growth do not lead to improved affinity of the antibody but may lower antibody activity.

Because of the very low frequency of cells that produce any specific antibody even in an immunized individual, there is an obvious need to apply a highly sensitive selection method to enrich for the specific cells. Selection takes advantage of the cell-surface expression of the specific antibody on B cells. Alternatively, individual cells (or clones) can be selected simply by assessing their capacity to secrete the specific antibody.

As a rule, peripheral blood lymphocytes are used as a source for establishing antibody-producing cell lines, but even spleen and lymph node-derived cells can serve this purpose.

Numerous laboratories have successfully applied the EBV method to generate IgM, IgG, and IgA-specific antibodies against proteins, carbohydrates and peptides. The monoclonal antibodies

produced by the EBV method resemble antibodies that have emerged in vivo against a specific pathogen. These antibodies may be relevant to future clinical applications such as anti-pathogen passive immunization. Moreover, monoclonal antibodies that are produced by the EBV method from patients with immune disorders and which resemble pathogenic antibodies are valuable reagents for the study of these abnormalities.

The monoclonal antibodies secreted by EBV-immortalized cell lines are purified from the cell culture medium. Alternatively, the cDNA of the immunoglobulin genes can be readily isolated from the antibody-secreting LCL's and used for transfection of cells and bacteria in order to produce large amounts of the antibody.

2 Materials

2.1 Isolation of Lymphocytes

1. A freshly drawn blood sample (10 ml or more) supplemented with any type of anticoagulant or a buffy coat derived from a blood center, is a suitable source of lymphocytes. The blood samples and buffy coats are diluted with phosphate-buffered-saline (PBS).
2. PBS: 0.14 M NaCl (8.0 g), 2.7 mM KCl (0.2 g), 8.0 mM Na₂HPO₄ (1.15 g), 1.4 mM KH₂PO₄ (0.2 g), in double distilled water (1 l), adjusted to pH 7.5. An autoclaved stock solution of 10× concentrated PBS can be prepared in advance.
3. Sterile Ficoll Isopaque (1.077 g/ml) is commercially available.
4. A concentrated (×100) stock solution of 100 µg/ml sterile cyclosporin A (Sandoz, Holzkirchen, Germany) in PBS can be prepared in advance, divided into small aliquots and frozen at -20 °C until use.

2.2 Infection of Cells with EBV and Outgrowth of Lymphoblastoid Cell Lines

1. The EBV reagent used for immortalization is the cell supernatant harvested from the B95-8 marmoset cell line [15] (*see Note 1*).
2. CpG ODN 2006 (5-tcgtcgtttgtcgtttgtcgtt-3), a commercially available 24-mer oligodeoxy nucleotide, is used to activate in vitro the isolated blood lymphocytes. The bases are phosphorothioated to render the compound nuclease-resistant. CpG ODN 2006 is dissolved in RPMI-1640, 10 % FCS at a concentration of 25 µg/ml, sterile-filtered and, kept at -20 °C. It is added to cell cultures at a final concentration of 2.5 µg/ml.
3. RPMI-1640 supplemented with penicillin and streptomycin 10 % FCS is used to grow EBV-immortalized lymphoblastoid cell lines. For some purposes this medium is supplemented with 20 % FCS.

2.3 Selection of Lymphocytes

2.3.1 Selection Based on Cell Surface Expression of Immunoglobulins

Selection of antigen-committed B cells is carried out with antigen-coated magnetic beads (*see Note 2*). The kind of magnetic device required for the isolation of the bead-attached cells depends on the type of magnetic beads used (*see Note 3*).

1. Selection of isotype-specific B lymphocytes.
Commercially available magnetic beads coated with anti-immunoglobulin heavy chain-specific antibodies are used to remove or enrich blood derived specific Ig surface-positive lymphocytes. Both microscopic and submicroscopic magnetic beads are suitable for selection.
2. Selection of antibody-specific B lymphocytes.
Activated magnetic beads (i.e., tosyl activated beads, Dynal, Invitrogen, USA) are coated under sterile conditions with the molecule in question, e.g., proteins, peptides, carbohydrates, or nucleic acids. If the peptides are very short they have to be linked to a large polymer before being coated onto the magnetic beads. It is recommended to prepare the specific peptides with an additional cysteine to enable conjugation to a carrier protein (such as albumin). A variety of chemical reagents for this kind of conjugation are commercially available (Pierce, USA).

2.3.2 Selection Based on Secretion of a Specific Antibody

Flat bottom 96-well microplates are used for oligoclonal growing cells.

2.4 Cloning of Cells

1. Flat bottom 96-well microplates are used to clone cells.
2. 2000 R irradiated blood-derived lymphocytes from any blood donor are used as feeder layer.

2.5 ELISA

Standard ELISA microplates are used for the detection of specific antibodies.

1. Saturation buffers (any one of the following solutions can be used): 50 % FCS in PBS.
3 % bovine serum albumin (BSA) in PBS.
Low-fat milk.
0.5 % gelatin in PBS.
2. Wash buffer.
1/10 diluted PBS with 0.05 % Tween 20.
3. Enzyme-conjugated anti-human immunoglobulin antibodies. These reagents should be diluted according to the manufacturer's instructions.
4. The ELISA substrate should be chosen in accordance with the type of conjugated enzyme reagent used in the test.

3 Methods

There are several alternative strategies for establishing EBV-immortalized lymphoblastoid cell lines that secrete human monoclonal antibodies. Figure 1 is a schematic of these options.

3.1 Isolation of Lymphocytes (See Note 4)

1. Carry out the entire procedure under sterile conditions.
2. Dilute the blood sample with one volume of PBS. If a buffy coat is used, dilute it with 100 ml PBS.
3. Separate the lymphocytes on a discontinuous Ficoll Isopaque gradient. Layer carefully two volumes of cell suspension onto one volume of Ficoll Isopaque in a 15 or 50 ml test tube, avoiding mixing of the two layers.

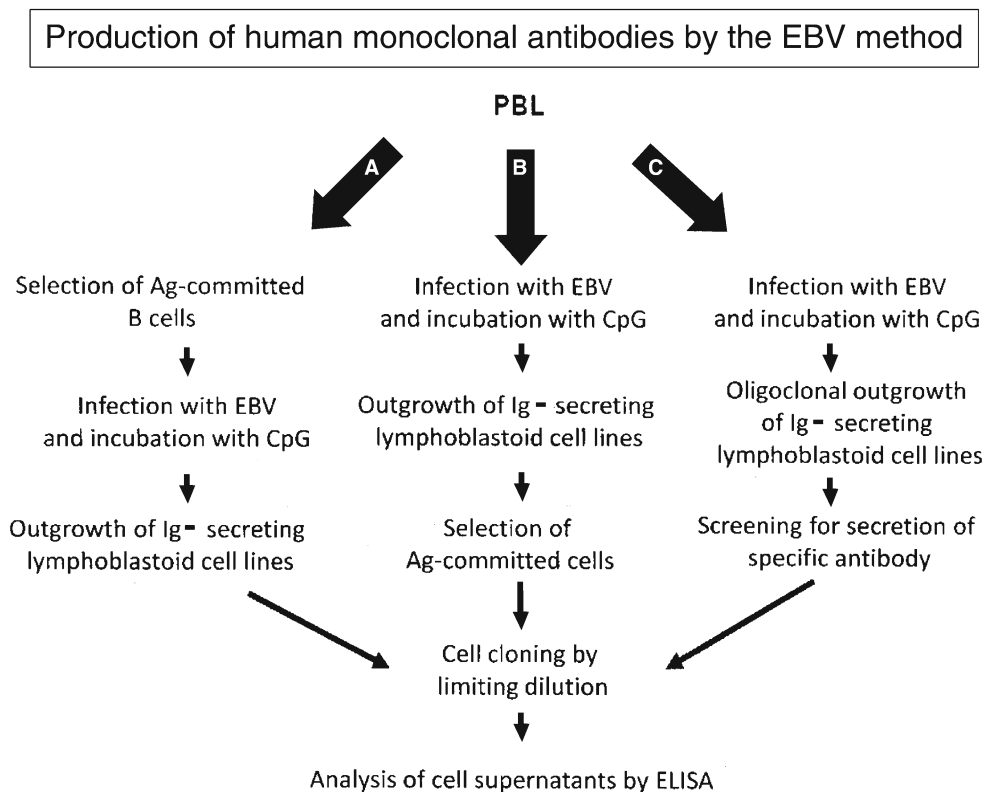

Fig. 1 Schematic showing the strategies involved in producing human monoclonal antibodies from peripheral blood lymphocytes, applying the EBV method. **(A)** Antigen-committed B lymphocytes are selected before EBV infection. **(B)** B lymphocytes, which first are infected with EBV, are allowed to proliferate in vitro and then, upon reaching around 10^7 cells, antigen-committed cells are selected. **(C)** Lymphocytes, which first are infected with EBV, are allowed to grow as oligoclonal in micro-wells and their supernatants are tested for the presence of specific antibodies. In all three schemes the cells are cloned by limiting dilution and finally the cell supernatants are tested, usually by ELISA, for the presence of the specific antibody

4. Centrifuge the test tubes for 20 min at 2,200 rpm (about $800\times g$), with no brake. The erythrocytes form a pellet at the bottom of the test tube; the lymphocytes (and platelets too) are located in the interphase above the Ficoll Isopaque layer.
5. Use a pipette to discard about 4/5 of the upper layer. Then collect into a test tube the interphase, which contains mainly lymphocytes and platelets. The interphase may be contaminated with some erythrocytes (often due to the fact that the blood sample is not fresh), which do not interfere with the process. Obviously, the recovered cell fraction will also contain some Ficoll Isopaque. Dilute the cell fraction with one volume of PBS, 1 % FCS and centrifuge for 10 min, 2,200 rpm (about $800\times g$) (*see Note 5*).

Discard the supernatant (*see Note 6*).

6. Suspend the cells in PBS, 1 % FCS and centrifuge the test tube at 1,100 rpm (about $300\times g$), 5 min. If the supernatant is turbid (reflecting the presence of platelets), washes should be repeated as above (i.e., centrifugation at 1,100 rpm, 5 min) until the supernatant is clear (*see Note 7*).

Suspend the cells in RPMI-1640, 10 % FCS and count. Usually, 10^6 lymphocytes are recovered from 1 ml blood and about 6×10^8 cells are recovered from the entire buffy coat.

3.2 Infection with EBV

1. Spin down the lymphocytes, gently resuspend, and add B95-8 virus-containing reagent (1 ml per 10^7 lymphocytes). Incubate the cells for 1 h at 37 °C. Then spin down the cells at 1,000 rpm for 5 min and discard the supernatant. Resuspend the cells at 10^6 cells/ml in RPMI-1640, 20 % FCS, 1 $\mu\text{g}/\text{ml}$ cyclosporin A, 2.5 $\mu\text{g}/\text{ml}$ CpG ODN (*see Notes 8 and 9*).

The direct result of the viral infection is that the B cells start to proliferate, with an average doubling time of 24 h. In bulk cultures of EBV-infected non-selected blood-lymphocytes (*see Note 10*) the T cells die out within 1–2 weeks. Cyclosporin A, added to the medium at 1 $\mu\text{g}/\text{ml}$, prevents the cytotoxic activity of the T cells against the EBV-immortalized cells. The lymphoblastoid cells, which grow as single cell suspension, forming typical clumps, usually reach a concentration of about 1.0×10^6 cells/ml.

3.3 Selection of Lymphocytes and Establishment of Antibody-Secreting Cell Lines

Cells should be selected before EBV infection (Fig. 1, option A) or when they have already been immortalized by the virus (Fig. 1, option B). When the aim is to establish cell lines that secrete IgG antibodies, it is recommended first to enrich for lymphocytes expressing IgG or to deplete IgM-positive cells before infection with EBV.

Selection of lymphocytes (and of cells derived from EBV-immortalized lines) takes advantage of the fact that the target cells of EBV (and also the lymphoblastoid cells) are

immunoglobulin surface-positive. Usually selection is performed with the aid of ligand-coated magnetic beads and an appropriate magnetic device (*see Note 3*).

1. On the day the lymphocytes are isolated and infected with the virus, resuspend them at a concentration of up to 50×10^6 cells/ml in RPMI-1640, 10 % FCS. It is important to have a single cell suspension and to avoid clumps. The mixture of cells and magnetic beads is now placed in a 1–2 or 5 ml capped test tube, depending on the total number of cells and the type of magnetic device used for selection. The entire procedure should be carried out at 4 °C. Centrifuge the suspension 15 min, 800 rpm (about $250 \times g$) and then keep on ice for 1 h.
2. Gently suspend the pellet, using a pipette with a relatively wide opening. The magnetic device is then used to isolate the beads with their attached cells. Keep the test tube adjoined to the magnet for 2 min, then open the tube and, while keeping it attached to the magnet, decant the fluid, leaving behind the beads and the beads specifically-bound B cells, still attached to the wall of the test tube. Close the tube, remove the magnet and add fresh cold medium as before. Gently resuspend the pellet and repeat the selection procedure five times.
3. Thoroughly resuspend the pellet and add 2×10^7 irradiated feeder cells in 20 ml RPMI-1640, 20 % FCS, 2,5 µg/ml CpG ODN. Seed 200 µl/well into a flat bottom 96-well microplate. Allow the cells to grow for about 4 weeks. There is no need to feed the cells during this period. The magnetic beads do not interfere with the growth of the cells.
4. Collect 100 µl supernatant samples from wells in which there is substantial cell growth and check for the presence of specific antibodies by ELISA or any other rapid assay. Count the cells in wells in which antibodies were detected and clone in flat bottom microplates at 0.5 cells/well with $1-2 \times 10^5$ irradiated feeder cells/well in RPMI-1640, 20 % FCS.
5. Transfer the antibody-producing clones to large tissue culture flasks and freeze in liquid nitrogen, $2-10^6$ cells per ampoule.

3.4 Establishment of Cell Lines that Secrete a Specific Antibody Without Selection of Antigen-Committed Cells

Sometimes, the number of available PBL is small and, in addition, selection of antigen-committed cells is not feasible: the antigen may not be available as a pure reagent or it is not possible to coat the beads with the antigen used for selection. In such cases, a different strategy is called for (*see Fig. 1*, option C). A small number of virus-immortalized antigen-non-selected cells are allowed to grow as oligoclonal in flat-bottom microwells together with irradiated allogeneic lymphocytes as feeder layer. When cell saturation is reached, the supernatants should be tested (usually by ELISA) for the presence of a specific antibody.

1. Dilute EBV-infected cells to a final concentration of 0.5×10^3 to 0.5×10^4 cells/ml in RPMI-1640, 20 % FCS, 1 $\mu\text{g}/\text{ml}$ cyclosporin A, 2.5 $\mu\text{g}/\text{ml}$ CpG ODN, and mix with 10^6 irradiated lymphocytes/ml. Then seed 200 μl in wells of 96-well flat-bottom microplates. Thus, each well will contain only 100–1,000 virus-infected B cells (*see Note 11*).

Incubate the microplates at 37 °C for about 4 weeks without refeeding (*see Notes 12 and 13*).

2. When the cells reach a concentration of about 2×10^5 cells/well, use a multichannel micropipette to collect and transfer a 100 μl supernatant sample from each well into a “master plate.” Then test the supernatants for the presence of specific antibodies (usually by a rapid ELISA).
3. Clone cells from wells that were positive in the ELISA.

3.5 Cloning of EBV-Immortalized Cells

EBV-immortalized cells cannot develop from a single cell unless supported by a feeder cell layer. Moreover, technically it is very difficult to get the cells to grow as monoclonal colonies in soft agar. The cells are therefore cloned by limiting dilution in microplate wells in the presence of 2000 R irradiated allogeneic blood-derived lymphocytes. These cells can be prepared in advance and kept frozen until used as feeder.

Mix one volume of irradiated lymphocytes derived from any blood donor, suspended in medium ($2\text{--}4 \times 10^6$ cells/ml) with one volume of the cell suspension (10 cells/ml) to be cloned. The cell mixture (200 μl) is now seeded in flat-bottom wells in a 96-well microplate, using a multichannel micropipette. Theoretically, under these conditions each well should contain one cell that is capable of proliferating. In practice, we suggest that cloning be performed in 5–10 microplates at a time, 2–3 of them seeded with 1–0.3 cells/well (*see Note 14*).

Wrap the microplates with aluminum foil and keep them in the incubator for 4 weeks without refeeding (*see Note 12*). Eventually the outgrowth of the LCL is clearly observed under an inverted microscope (*see Note 15*).

Transfer the cells collected from the wells to round bottom tissue culture test tubes containing 0.5 ml RPMI-1640, 20 % FCS. One week later transfer the cells to a tissue culture flask with 5 ml medium, as above (*see Note 16*).

3.6 ELISA

The supernatants derived from hundreds of microwells must be rapidly checked for the presence of specific antibodies. A standard ELISA is often the test of choice. Because of the small volume of available supernatant, ELISA should be performed using a 45 μl sample volume. For each supernatant a specific ELISA and a control ELISA are performed simultaneously. The control ELISA is performed identically with the exception that the wells are not coated with the specific antigen.

The ELISA wells should be coated with a relatively pure antigen solution (45 µl/well) in PBS buffer. Saturate the wells with 250 µl of a non-reactive protein solution (*see Note 17*). Then take two samples from every cell supernatant, each consisting of 45 µl, add one to an antigen-coated well, the other to its control well and leave for 1 h at RT (room temperature). Wash the plate as above and add enzyme-conjugated antibody against human immunoglobulins and leave for 1 h at RT. A color reaction develops upon the addition of a specific substrate (*see Note 18*).

4 Notes

1. The cells of this line grow partly as a suspension and are partly surface-attached in RPMI-1640, 10 % fetal calf serum (FCS). To prepare a culture supernatant with a high virus titer, the B95-8 cells are allowed to grow for 4–5 weeks in tissue culture flasks without refeeding. Virus-containing supernatants can be stored at 4 °C or frozen at –20 °C until use. The B95-8 cells are kept frozen in liquid nitrogen, with 10 % dimethyl sulfoxide (DMSO), 90 % FCS. In our experience not all the cells survive the freezing and thawing. However, the cells have an extremely high cloning efficiency and when cultured after being thawed, the cell line is rescued even if very few cells are alive.
2. Blood-derived B lymphocytes express IgM, IgG, IgA, and IgE isotypes, but it should be emphasized that the majority of the cells are IgM-positive. Therefore, if the aim is to establish cell lines that secrete IgG antibodies, it is recommended first to enrich for lymphocytes which express IgG or, alternatively, to deplete IgM-positive cells before infection with EBV.

As the target cells of EBV are immunoglobulin surface-positive B cells, their selection is straightforward. Usually selection is achieved with the aid of ligand-coated magnetic beads.
3. In the past when magnetic beads were not available, specific ligand-coated erythrocytes were used for this purpose [16]. At 4 °C the ligand-coated erythrocytes form rosettes with B cells which express on their surface the corresponding antibody. The rosettes are then easily and very efficiently separated from non-rosetting cells on a discontinuous Ficoll Isopaque gradient, similarly to the separation of blood lymphocytes described elsewhere (*see Subheading 3.1*).
4. The end product of this procedure should be a single cell suspension of lymphocytes with no cell clumps or platelets. Platelets tend to aggregate and also to cause aggregation of lymphocytes. Therefore it is essential to repeat the washes described in Subheading 3.1 until no more platelets remain.

The presence of clumped cells will dramatically worsen selection, as performed in the following steps.

5. In the first wash, the cells are centrifuged at high speed because of the presence of some Ficoll Isopaque in the sample. Under these conditions both cells and platelets are pelleted. However, in the subsequent washes, the test tubes are spun at 1,100 rpm, 5 min, so that the lymphocytes are pelleted, whereas the platelets remain in the supernatant.
6. After discarding the supernatant and prior to any addition of wash solution the cell pellet should be gently resuspended by thoroughly stirring the test tube. This is crucial to avoid formation of cell clumps.
7. Usually three washes are sufficient to remove the platelets but sometimes more washes are required.
8. We usually infect the cells immediately after the lymphocytes have been isolated. However, lymphocytes can be kept overnight on ice in RPMI-1640, 10 % FCS before being infected with the virus. Leaving the cells in the incubator at 37 °C may decrease cell viability and cause non-desired activation of the B cells.
9. CpG ODN was shown to increase dramatically the efficiency of EBV-induced immortalization of B cells [17].
10. The initially isolated cells are a mixture of cells containing only about 10 % B cells.
11. When EBV-immortalized cells are seeded as described, only about 5 % will proliferate into cell lines. Therefore, only 15–150 different B cell clones will develop in each well.
12. The irradiated cells of the feeder layer disintegrate within a short time, whereas the number of the lymphoblastoid cells gradually increases. If the cells are widely dispersed, outgrowth will be poor. It is therefore recommended that about 8 days after seeding, the microplate should be tilted so that all the cells are allowed to slide down to the lower “corner” of the wells. An object, such as an ordinary pencil, is positioned under the microplate at its edge to keep the plate permanently tilted. The fact that the cells are now closely positioned to each other facilitates their outgrowth.
13. There is no need under the conditions described above to refeed the wells during the 4 weeks of culture. It is, however, mandatory to cover each microplate with aluminum foil to decrease evaporation.
14. When cloning the cells it is preferable to seed an average 0.3 cells/well to increase the chances of outgrowth mono-clonality.
15. EBV-immortalized cells (either freshly infected or cells derived from established cell lines) have a low efficiency of cloning, even when grown together with a feeder layer. We have cloned

LCL's numerous times using the limiting dilution method, with allogeneic irradiated blood-derived lymphocytes as feeder. The average cloning efficiency is 15 %. This means that when seeding in a microplate at 0.3 cell/well, there should be cell line outgrowth in about three to four wells per 96-well microplate.

16. It is recommended to place the flask upright, slightly tilted, so that the cells will slide down to one corner of the vessel. Lymphoblastoid cells in close proximity tend to grow out better, particularly when starting as a sparse culture.
17. Usually, 50 % FCS in PBS is the saturation buffer of choice. However, if the background absorption values in the control wells are high (because of the interaction of ELISA reagents with FCS) PBS with BSA, low-fat milk or gelatin is used for saturation (*see* Subheading 2.5).
18. Supernatants derived from five microplates (i.e., 480 wells) can easily be tested simultaneously by ELISA during one day and by one person. The day before the assay, add to each well 45 μ l, antigen, incubate for 1 h at room temperature and then leave overnight at 4 °C. The concentration of antigen used to coat ELISA microwell varies, depending on the type of molecule used. If the antigen is a protein, then usually 1–2 μ g/ml is optimal. High concentrations of antigen might cause interference whereas low concentrations will result in a weak optical signal. The following day knock out the plates to empty the wells, add 250 μ l of a saturation buffer to block the remaining free surface of the wells. Similarly saturate five control plates (devoid of antigen) with saturation solution. On the day before the assay, use a multichannel micropipette to collect supernatants (100 μ l/well) from the five tissue culture microplates in which the immortalized cells grew. Add the supernatants to five similarly marked 96-well round bottom “master microplates” at the locations corresponding to those of the original tissue culture microplates.

On the day the assay is performed, wash the ELISA plates four times by dipping each plate in a dish with the wash buffer and knock out the contents. It should take about 5 min to wash ten plates (i.e., five test microplates and the corresponding five control microplates), four washes each. After the last wash, leave the wash solution in the microplates. Empty one antigen-coated microplate and the corresponding control plate by knocking out the fluids. Use a multichannel micropipette to transfer the supernatants' samples (each 45 μ l) from the “master microplate” to the corresponding wells in the antigen-coated ELISA microplate and to the corresponding control microplate. Repeat the procedure for the remaining microplates. Handle only two plates at a time (as described above) to avoid drying out the ELISA microplates.

If the antigen is a costly reagent then it is recommended to collect the antigen solution from the wells before adding the saturation buffer and save it for future use in ELISA. Obviously, the concentration of rescued antigen will be somewhat lower compared with the original antigen solution.

Acknowledgment

The help of Dr. A. Mahler in preparing the manuscript is greatly appreciated.

References

1. Nilsson K, Ponten J (1975) Classification and biological nature of established human hematopoietic cell lines. *Int J Cancer* 15:321–341
2. Steinitz M, Klein G, Koskimies S, Mäkelä O (1977) EB virus-induced B lymphocyte cell lines producing specific antibody. *Nature* 269:420–422
3. Kuppers R (2003) B cells under influence: transformation of B cells by Epstein-Barr virus. *Nat Rev Immunol* 3:801–812
4. Nemerow GR, Wolfert R, McNaughton ME, Cooper NR (1985) Identification and characterization of the Epstein-Barr virus receptor on human lymphocytes-B and its relationship to the C3d complement receptor (Cr-2). *J Virol* 55:347–351
5. Heath E, Begue-Pastor N, Chaganti S, Croom-Carter D, Shannon-Lowe C, Kube D, Feederle R, Delecluse HJ, Rickinson AB, Bell AI (2012) Epstein-Barr virus infection of naive B cells in vitro frequently selects clones with mutated immunoglobulin genotypes: implications for virus biology. *PLoS Pathog* 8(5):e1002697
6. Ehlin-Henriksson B, Gordon J, Klein G (2003) B-lymphocyte subpopulations are equally susceptible to Epstein-Barr virus infection, irrespective of immunoglobulin isotype expression. *Immunology* 108:427–430
7. Brown NA, Miller G (1982) Immunoglobulin expression by human lymphocytes-B clonally transformed by Epstein-Barr virus. *J Immunol* 128:24–29
8. Miyawaki T, Kubagawa H, Butler JL, Cooper MD (1988) Ig isotypes produced by Ebv-transformed B-cells as a function of age and tissue distribution. *J Immunol* 140:3887–3892
9. Stein LD, Chan MA, Hibi T, Dosch HM (1986) Epstein-Barr virus-induced Ige production in limiting dilution cultures of normal human B-cells. *Eur J Immunol* 16:1167–1170
10. Steinitz M, Klein G (1980) Ebv-transformation of surface Iga-positive human-lymphocytes. *J Immunol* 125:194–196
11. Shannon-Lowe C, Baldwin G, Feederle R, Bell A, Rickinson A, Delecluse HJ (2005) Epstein-Barr virus-induced B-cell transformation: quantitating events from virus binding to cell outgrowth. *J Gen Virol* 86:3009–3019
12. Gil Y, Levy-Nabot S, Steinitz M, Laskov R (2007) Somatic mutations and activation-induced cytidine deaminase (AID) expression in established rheumatoid factor-producing lymphoblastoid cell line. *Mol Immunol* 44:494–505
13. Chezar I, Lobel-Lavi L, Steinitz M, Laskov R (2008) Ongoing somatic hypermutation of the rearranged VH but not of the V-lambda gene in EBV-transformed rheumatoid factor-producing lymphoblastoid cell line. *Mol Immunol* 46:80–90
14. Laskov R, Yahud V, Hamo R, Steinitz M (2011) Preferential targeting of somatic hypermutation to hotspot motifs and hypermutable sites and generation of mutational clusters in the IgVH alleles of a rheumatoid factor producing lymphoblastoid cell line. *Mol Immunol* 48:733–745
15. Miller G, Lipman M (1973) Comparison of yield of infectious virus from clones of human and simian lymphoblastoid lines transformed by Epstein-Barr-virus. *J Exp Med* 138:1398–1412
16. Steinitz M, Tamir S, Frodin JE, Lefvert AK, Mellstedt H (1988) Human monoclonal anti-idiotypic antibodies. I. Establishment of immortalized cell-lines from a tumor patient treated with mouse monoclonal-antibodies. *J Immunol* 141:3516–3522
17. Traggiai E, Becker S, Subbarao K, Kolesnikova L, Uematsu Y, Gismondo MR, Murphy BR, Rappuoli R, Lanzavecchia A (2004) An efficient method to make human monoclonal antibodies from memory B cells: potent neutralization of SARS coronavirus. *Nat Med* 10:871–875

Humanization and Simultaneous Optimization of Monoclonal Antibody

T. Kuramochi, T. Igawa, H. Tsunoda, and K. Hattori

Abstract

Antibody humanization is an essential technology for reducing the potential risk of immunogenicity associated with animal-derived antibodies and has been applied to a majority of the therapeutic antibodies on the market. For developing an antibody molecule as a pharmaceutical at the current biotechnology level, however, other properties also have to be considered in parallel with humanization in antibody generation and optimization. This section describes the critical properties of therapeutic antibodies that should be sufficiently qualified, including immunogenicity, binding affinity, physiochemical stability, expression in host cells and pharmacokinetics, and the basic methodologies of antibody engineering involved. By simultaneously optimizing the antibody molecule in the light of these properties, it should prove possible to shorten the research and development period necessary to identify a highly qualified clinical candidate and consequently accelerate the start of the clinical trial.

Key words Humanization, Immunogenicity, Optimization, Protein expression, Stability, Pharmacokinetics, Optimization

1 Introduction

Monoclonal antibody recognizes antigen with high affinity and neutralizes the function of the antigen. In addition, it binds to the antigen-expressing cells and triggers effector functions that eliminate those cells, through antibody-dependent cellular cytotoxicity (ADCC) or complement-dependent cytotoxicity (CDC), via its Fc region. In the area of autoimmune diseases, antibodies that neutralize the function of inflammatory cytokines, such as IL-6 receptor or tumor necrosis factor, have shown significant efficacy in patients with rheumatoid arthritis [1–4] and, in the area of cancer diseases, antibodies that recognize tumor antigens, such as CD52 or CD20, and eliminate the cancer cells that express them by triggering the effector function have shown survival benefit [5, 6]. Because these monoclonal antibodies have shown higher efficacy with fewer side effects than classical small molecule drugs,

monoclonal antibodies now play an important role in the therapeutic field of various disease areas. To date, 32 recombinant monoclonal antibodies have been approved by the FDA, and more than 300 new candidates are entering into clinical trials [7, 8].

Before the recent success of monoclonal antibodies, initial clinical studies of murine monoclonal antibodies obtained from hybridoma technology were hampered by the development of human anti-murine antibody (HAMA) response [9, 10]. As a result of the response, therapeutic murine monoclonal antibodies were cleared so rapidly from the body that efficacy in the clinical trial was limited.

To address these issues of murine-derived monoclonal antibodies, antibody engineering technology has been developed to generate chimeric and humanized antibodies in which the immune response (immunogenicity) against murine-derived monoclonal antibodies is reduced [11, 12]. Mouse–human chimeric antibody, in which the mouse constant region of murine-derived monoclonal antibody was replaced with a human constant region, significantly reduced the risk of immunogenicity. Furthermore, humanized antibody, in which mouse complementarity-determining regions (CDRs) of mouse–human chimeric antibody were grafted into human frameworks, further reduced the risk of immunogenicity while maintaining the therapeutic activity of the murine or chimeric antibody [13]. The method for generating humanized antibody from murine antibody, called CDR-grafting humanization, significantly contributed to the current success of therapeutic monoclonal antibodies [12].

A number of novel technologies have been reported that further reduce the potential immunogenicity of CDR-grafted humanized antibody [14, 15]. Aiming to reduce the potential immunogenicity of framework residues, researchers have used frameworks based on human germline sequences or consensus sequences as acceptor human frameworks rather than human frameworks with somatic mutation(s), which may include effector T cell epitopes for some individuals [16–18]. Furthermore, aiming to reduce the potential immunogenicity of nonhuman CDRs, grafting specificity-determining residues (SDRs) has been proposed [19–21]. Instead of grafting the entire mouse CDRs into an acceptor human framework, only the SDRs, the minimum CDR residues required for antigen-binding activity, are grafted into the human germline framework. This SDR grafting method results in improved humanness (similarity to human germline sequence) of the humanized antibody and may reduce the number of effector T cell epitopes in the mouse CDRs, potentially minimizing the risk of immunogenicity of the variable region. However, the exact effects of these additional humanization technologies (germline humanization and SDR grafting) on clinical immunogenicity have not been addressed in clinical.

Since the field of therapeutic monoclonal antibodies has become extremely competitive nowadays, especially against validated

antigens, it is necessary to develop highly optimized antibody, not simply humanized antibody [22–25]. Highly optimized humanized antibody would have superior pharmacological properties important for clinical efficacy, such as high antigen-binding activity and long half-life, as well as biophysical properties important for commercial development of the therapeutic antibody, such as stability and expression yield. In order to efficiently generate such highly optimized antibody, it is necessary to consider these pharmacological and biophysical properties during the process of humanization.

A humanization process enabling the generation of highly optimized monoclonal antibody consists of five steps. The first step is to construct a three-dimensional structure model of parental nonhuman antibody by homology modeling. The second step is to select acceptor human frameworks appropriate for their antigen-binding activity, immunogenicity, expression, stability, and pharmacokinetics. The third step is to prepare expression vectors for multiple versions of humanized antibodies. The fourth step is to express and purify the humanized antibodies. The last step is to multidimensionally evaluate the humanized antibodies.

2 Materials

2.1 *Selecting a Framework*

1. 3D modeling software or Web server (Accelrys Inc., CCG (Chemical Computing Group)), WAM (Web Antibody Modeling), PIGS (Prediction of ImmunoGlobulin Structure), or Rosetta Antibody Modeling Server (Rosetta Antibody).
2. GENETYX (GENETYX CORPORATION).

2.2 *Expression and Purification*

1. FreeStyle 293 Expression System (Life Technologies Corporation).
2. FreeStyle 293 Expression Medium (Life Technologies Corporation).
3. 293 fectin (Life Technologies).
4. MILLEX-GV (0.22 or 0.45 μm).
5. rProtein A Sepharose™ Fast Flow (GE Healthcare).

2.3 *Antigen-Binding Activity*

1. Biacore T200 (GE Healthcare).
2. Recombinant protein A/G (Thermo Fisher Scientific Inc.).
3. Sensor chip (CM4, GE Healthcare).
4. Biacore T200 Evaluation Software (GE Healthcare).

2.4 *DSC (Differential Scanning Calorimetry) Analysis*

1. Microcal VP-Capillary DSC System (GE Healthcare).
2. PBS.
3. Origin 7.0 Software (OriginLab Corporation).

2.5 Size Exclusion Chromatography (SEC) Analysis

1. Alliance System (Waters, Milford, MA).
2. TSK gel G3000SWXL column (7.8 mm × 300 mm).
3. 50 mM sodium phosphate, 300 mM sodium chloride, pH 7.0.

2.6 Pharmacokinetics

1. C57BL/6J normal mice.
2. Anti-human IgG.
3. WinNonlin Professional (version 4.0.1) Software (Pharsight).

3 Methods

3.1 Antibody Humanization

3.1.1 Constructing a Structure Model of the Parental Variable Region

If a crystal structure of the parental nonhuman antibody is not available, construct a homology model using available modeling methods. A number of well-established antibody modeling programs based on homology and conformational searching algorithms have been reported [26–31]. Computer software incorporating these methods is commercially available.

3.1.2 Selecting a Framework

Selecting the acceptor human frameworks while considering the four key factors—immunogenicity, antigen-binding activity, expression/stability, and pharmacokinetics—is the most important step in obtaining highly optimized humanized antibody. The conventional CDR-grafting method uses single acceptor human frameworks (frameworks 1, 2, 3, and 4 derived from single human antibody germline sequence) for grafting parent CDRs and, therefore, it is generally difficult to meet all four key factors. In such cases, each nonhuman framework (framework 1, 2, 3, and 4) should be individually humanized by selecting the most appropriate human germline framework for that framework while considering all four key factors (Fig. 1). This approach, called framework shuffling, enables the selection of more desirable human frameworks for generating highly optimized humanized antibody—those which are not only less immunogenic but also have high stability/expression and longer half-life.

1. Align each parental nonhuman antibody framework sequence (heavy chain framework 1, 2, 3, and 4 and light chain framework 1, 2, 3, and 4) with the human germline framework sequences obtained through the protein database, such as IMGT, V BASE, EMBL, or NCBI (*see Notes 1 and 2*).
2. Check the residues comprising the upper hydrophobic core within the immunoglobulin domain: these are located at positions 2, 4, 24, 27, and 29 in framework 1; 69, 71, 78, and 94 in framework 3 of the heavy chain, and at positions 2 and 4 in framework 1; and 64, 66, and 71 in framework 3 of the light chain of the parental nonhuman antibody framework sequence (residue positions are described in Kabat numbering) [32, 33] (Table 1).

residues are as follows: hydrophobic residues which comprise upper and lower hydrophobic cores that are important for packing of the immunoglobulin domain and conformation of framework 1 [34, 35]; hydrophilic core residues which comprise the hydrogen bond network within the immunoglobulin domain; residues in turn structures (ϕ -angle); and residues located in the VH/VL interface (Table 1).

5. All the above residues are highly conserved depending on the germline subgroups, especially those in the VH domain. To select appropriate human germline frameworks that are homologous to the parental nonhuman antibody framework, compare consensus residues and a structure model of parental nonhuman antibody with those of the consensus human germline antibodies (Table 1). Considering the similarity of the sequence and the structure, select a human germline framework with the correct residues at the correct positions as a template (*see Notes 4–6*).
6. Determine the amino acid residues in the framework of parental nonhuman antibody which might influence antigen-binding activity. Amino acid residues that potentially influence the antigen-binding activity are summarized in Table 1. Check whether these residues could interact with the antigen by constructing a structure model of the parental nonhuman antibody.
7. Compare the parental nonhuman antibody framework with the parental nonhuman germline framework with the highest homology, to identify distinctive amino acids in the framework. These distinctive amino acids derived from somatic mutation(s) in the framework might affect the antigen-binding activity.
8. To generate humanized antibody with a longer half-life, select low isoelectric point (pI) frameworks containing larger numbers of Glu and Asp residues and smaller numbers of Arg and Lys residues (*see Note 7*).
9. Check how frequently the selected germline framework sequences are used in human antibodies. If the frequency is extremely low, it could be immunogenic in some individuals. In such cases, reconsider whether another germline sequence with high frequency could be selected (*see Note 8*).
10. There are no key residues in framework 4, therefore select the human germline sequence with the highest homology in the J region as framework 4.
11. Compare the sequence of the designed humanized antibody framework with that of the parental nonhuman antibody.
12. Check all the different amino acids between the designed humanized antibody framework and the parental nonhuman antibody.

13. Check whether these different amino acids could affect the CDR conformation or antigen-binding activity using a constructed parental nonhuman structure model. Generally, amino acid residues that are exposed on the surface of the antibody and are distant from the CDRs do not affect the antigen-binding activity.
14. Check whether or not the selected human germline frameworks have potential chemical modification sites, such as a deamidation site (Asn-Gly), an isomerization site (Asp-Gly), a surface exposed methionine residue, and a glycosylation site (Asn-X-Ser/Thr, where X is not Pro).
15. Check again all the processes from Subheadings 3.1.2, steps 1–14 to confirm that there is no omission.
16. Finally select the appropriate human germline frameworks for 1, 2, 3, and 4, considering the stability, immunogenicity (germline frequency), pharmacokinetics (isoelectric point), and other chemical modification motifs (*see* Notes 9–11).
17. Select the human signal sequence which is derived from the germline sequence used in framework 1 of the humanized antibody. The amino acid of the signal sequence can be obtained from the protein database described above (*see* Note 2).

3.1.3 Designing Versions of Humanized Antibodies

After designing the amino acid sequence of the variable region of the humanized antibody by connecting selected human germline frameworks with parental nonhuman CDRs, care should be taken on the boundary regions of selected human frameworks and parental nonhuman CDRs. For example, as a result of connecting the human germline frameworks and the parental nonhuman CDRs, a potential deamidation site or glycosylation site might be generated on the boundary region. Presence of such modification sites could affect the commercial development of the humanized antibody. It is also possible to reduce potential immunogenicity by paying attention to the amino acid sequences of the boundary regions of selected human germline frameworks and nonhuman CDRs to increase humanness.

1. Design the amino acid sequence of the variable regions of designed humanized antibody by connecting individually selected human germline framework 1, 2, 3, and 4 and CDR 1, 2, and 3 of parental nonhuman antibody.
2. In the amino acid sequences of the boundary regions between the frameworks and CDRs, check whether a deamidation site (Asn-Gly), isomerization site (Asp-Gly), or glycosylation site (Asn-X-Ser/Thr, where X is not Pro) has been generated or not.
3. In the amino acid sequences of the boundary regions between the frameworks and CDRs, check whether designed boundary

regions match with corresponding human germline boundary sequences. If they do not match, consider using another human germline framework can be used as an acceptor framework. For example, Thr-Cys, Ser-Cys, and Asn-Cys are predominant amino acids at positions 22 and 23 of the light chain of the framework. If amino acids at positions 24 and 25 of the light chain of the CDR are Arg-Ser, amino acids at positions 22 and 23 of the framework are generally restricted to either Ser-Cys or Asn-Cys. If the selected framework amino acids at positions 22 and 23 are Thr-Cys, the potential immunogenicity risk of this variable region would be higher than using a framework with Ser-Cys or Asn-Cys at positions 22 and 23. In such cases, consider whether a germline framework with Ser-Cys or Asn-Cys at position 22 and 23 of the light chain could be selected (*see* **Note 12**).

3.1.4 *Expressing and Purifying Humanized Antibody*

1. Design the nucleotide sequences from the amino acid sequences of designed humanized variable regions and synthesize a designed cDNA sequence (*see* **Notes 13** and **14**).
2. Insert the synthesized cDNA fragments of the full-length heavy and light chains (including signal sequence, humanized variable region sequence, and human constant region sequence) into a mammalian cell expression vector to construct the designed humanized antibody heavy chain and light chain expression vectors, respectively. Confirm the nucleotide sequences of the prepared expression vectors by DNA sequencing.
3. Transiently express the antibody with FreeStyle 293 Expression System.
4. Centrifuge the culture supernatants to remove cells and filter them through an 0.45 or 0.22 μm filter. Purify the antibody from the obtained culture supernatants by using rProtein A Sepharose™ Fast Flow.
5. Determine the concentration of the purified antibody by measuring the absorbance at 280 nm using a spectrophotometer and calculating the antibody concentration from the determined values using an absorbance coefficient calculated as previously described.

3.2 *Evaluating Humanized Antibody Variants*

Evaluating the humanized antibody variants in terms of antigen-binding activity, immunogenicity, pharmacokinetics, thermal stability (melting temperature), and accelerated stability study under elevated temperature is necessary for selecting highly optimized humanized antibody. However, it is not efficient to evaluate all these properties for a large number of generated humanized antibody variants, since some of them might have lower antigen-binding activity than the parental nonhuman antibody. Therefore, evaluating

antigen-binding activity, thermal stability, expression level, and aggregation tendency, which are somewhat easy to conduct, is recommended as a primary screening when selecting highly optimized antibody.

3.2.1 Antigen-Binding Activity

Assess the antigen-binding activity of the humanized antibody variants described above by using Biacore T200.

1. Capture purified humanized antibody variants to recombinant protein A/G immobilized onto a sensor chip by an amino-coupling method.
2. Inject appropriate concentrations of the target antigen as an analyte.
3. Analyze the obtained sensorgrams by Biacore T200 Evaluation Software, and determine the KD (M) of each humanized antibody variant (*see* **Notes 15** and **16**).

3.2.2 DSC (Differential Scanning Calorimetry) Analysis

Assess the thermal stability of humanized antibody variants by measuring the melting temperature (T_m) using Microcal VP-Capillary DSC System.

1. Dilute or dialyze the test sample at 0.15 mg/ml concentration into PBS, and use the corresponding buffer as a reference.
2. Scan the sample from 20 to 115 °C at a rate of 240 °C/h. Use a filtering period of 8 s and analyze the data using Origin 7.0 Software.
3. Correct the result of thermograms by subtracting that of the control buffer and determine the T_m of each humanized antibody variant.

3.2.3 Expression Level Analysis

Assess the expression level of each humanized antibody variant by comparing the concentration of purified antibodies in Subheading 3.1.4. However, the concentration of purified humanized antibody is affected not only by the expression level but also by the purification efficiency or recovery. If the precise expression levels of antibody variants are needed, antibody concentration in the supernatant should be determined by Biacore or ELISA using human IgG detection system.

3.2.4 Size Exclusion Chromatography (SEC) Analysis

Evaluate the aggregation tendency of humanized antibody variants by SEC using the high performance liquid chromatography.

1. Inject the humanized antibody variants into a TSK gel G3000SWXL column (7.8 mm × 300 mm) at a flow rate of 0.5 ml/min. Use 50 mM sodium phosphate, 300 mM sodium chloride, pH 7.0 as a mobile phase buffer.
2. Detect the eluted humanized antibody variants by UV absorbance at 215 nm.

3. Analyze the data and calculate the content of aggregate (%) using Empower2 installed in Alliance System.

3.3 Analyzing Framework Back Mutation

By selecting the frameworks 1, 2, 3, and 4 that conserve all the upper core and key structure residues, the humanized antibody generally maintains an equivalent antigen-binding activity to parental nonhuman antibody. However, if none of the humanized antibody variants can maintain an antigen-binding activity equivalent to the parental nonhuman antibody, framework back mutation should be conducted.

1. Shuffle the parent and humanized heavy (VH) and light (VL) chain domains, and analyze the antigen-binding activity to identify which domain(s) is responsible for the loss of antigen-binding activity (*see Note 17*).
 - (i) Humanized VH/Humanized VL.
 - (ii) Humanized VH/Parent VL.
 - (iii) Parent VH/Humanized VL.
 - (iv) Parent VH/Parent VL.
2. Replace each human germline framework sequence in the VH and/or VL that is responsible for the loss of binding with the sequence from the parental nonhuman framework. Specifically, generate the following (a)–(d) antibodies, in which one of the four human germline frameworks is replaced with the parental nonhuman framework. Analyze the antigen-binding activity of these antibodies, and identify which framework(s) is responsible for the loss of antigen-binding activity.
 - (a) pGL FR1_hGL FR2_hGL FR3_hGL FR4.
 - (b) hGL FR1_pGL FR2_hGL FR3_hGL FR4.
 - (c) hGL FR1_hGL FR2_pGL FR3_hGL FR4.
 - (d) hGL FR1_hGL FR2_hGL FR3_pGL FR4.

(hGL is the selected human germline sequence, and pGL is the parental nonhuman antibody framework.)
3. To identify the amino acid residue(s) that is responsible for the loss of antigen-binding activity, compare the amino acid sequence of each human germline framework with that of the parental nonhuman antibody. Check the position of these amino acids using the constructed structure model to determine whether these amino acids should be substituted simultaneously or not. If these different amino acids are in close contact to each other and are expected to affect antigen-binding activity cooperatively, substitute these amino acids simultaneously to those of parental nonhuman antibody. If these amino acids are not in close contact to each other and contribute to the

antigen-binding activity independently, substitute these amino acids separately. Determine the antigen-binding activity of these variants as described above.

3.4 Selecting Highly Optimized Humanized Antibody

After obtaining the humanized antibody variants which show comparable antigen-binding activity to that of parental nonhuman antibody, conducting pharmacokinetics, and predicting the risk of immunogenicity are recommended as a second screening to select highly optimized humanized antibody.

3.4.1 Pharmacokinetics

1. Administer each humanized antibody variant at an appropriate dose to C57BL/6J normal mice by single intravenous (i.v.) or subcutaneous (s.c.) injection.
2. Collect blood samples from each mouse at an appropriate time after the injection.
3. Determine the concentration of each antibody in mouse plasma using anti-human IgG ELISA.
4. Calculate pharmacokinetic parameters (elimination half-life, clearance, and bioavailability) from the plasma concentration–time data using noncompartmental analysis of WinNonlin Professional (version 4.0.1) Software.

3.4.2 Immunogenicity

1. Predict the number of T cell epitope(s) which may be present in the humanized antibody using an *in silico* tool (*see Note 12*).
2. To evaluate the potential immunogenicity, perform an HLA binding assay which measures binding activity of the peptides with MHC class II or an *in vitro* T cell assay using the peptides. Peptides for these assays can be selected by *in silico* prediction. These assays can identify the potential immunogenic peptides in the entire sequence of the humanized antibody.
3. To analyze the potential immunogenicity of whole humanized antibody, perform an *in vitro* T cell assay, which detects the T cell response to humanized antibody by ELISPOT or T cell proliferation.

3.4.3 Selection of Highly Optimized Humanized Antibody

After obtaining pharmacological and biophysical properties of humanized antibody, these properties should be compared with each other to select the highly optimized humanized antibody. If there is just one highly optimized humanized antibody that has superior pharmacological and biophysical properties compared with all other humanized antibody variants, this can be the clinical candidate. However, such cases are very rare and, in most cases, some properties are superior, but other properties are not. Therefore, the key factors (antigen-binding activity, immunogenicity, stability/expression, and pharmacokinetics) should be prioritized according to the properties required for the humanized antibody.

If a subcutaneous formulation is required, stability and pharmacokinetics may have higher priority since a stable and high-concentration formulation needs to be developed. For oncology diseases, immunogenicity might not be the highest priority since the immune response is often compromised in cancer patients.

4 Notes

1. Using human germline frameworks instead of human antibody frameworks with somatic mutation(s) as the acceptor frameworks could reduce the potential immunogenicity of the humanized antibody.
2. The protein database can be accessed through the Web addresses of IMGT (<http://www.imgt.org/>), V BASE (<http://vbase.mrc-cpe.cam.ac.uk/>), EMBL (<http://www.ebi.ac.uk/embl/>), or NCBI (<http://www.ncbi.nlm.nih.gov/>).
3. Upper hydrophobic core residues are key residues for determining CDR structures and strongly affect the antigen-binding activity after CDR grafting. However, human germline sequences which conserve all the upper hydrophobic core residues may not be identified. In such a case, prepare human germline framework sequence variants in which upper hydrophobic core residues are substituted with those of the parental nonhuman framework to enable generation of humanized antibody which maintains an antigen-binding activity equivalent to that of parental nonhuman antibody. After this, check the possibility of back-mutating these substituted amino acid(s) to the germline sequence in order to minimize potential immunogenicity. This approach enables humanization to be completed quickly and allows properties to be optimized through the CDRs and the frameworks simultaneously.
4. Seven VH and seven VL (four of Kappa and three of Lambda) human germline consensus sequences have been generated by sequence homology and the conserved structure residues for each germline sequence have been identified [33].
5. Physicochemical properties of antibodies with these consensus sequences have been evaluated and have revealed that germline families of the heavy chain have a significant effect on the expression and stability of single-chain Fv, and that the VH3 germline family appears to have favorable properties. However, there is a report that CDR grafting into a VH3 germline framework does not necessarily result in stable single-chain Fv [36]. These reports indicate that several factors, including CDR sequences, contribute to the stability of humanized antibodies rather than a single parameter such as germline family.

6. A model structure of each consensus family can be obtained through the PDB database. Accession numbers of each subgroup are as follows: VH1a (1DHA), VH1b (1DHO), VH2 (1DHQ), VH3 (1DHU), VH4 (1DHV), VH5 (1DHW), VH6 (1DHZ), VK1 (1DGX), VK2 (1DH4), VK3 (1DH5), VK4 (1DH6), V λ 1 (1DH7), V λ 2 (1DH8), and V λ 3 (1DH9).
7. Antibody with lower pI has longer half-life [37]. Lower pI antibody has a more negatively charged antibody surface in plasma, which reduces the nonspecific uptake of the antibody into the cell by electrostatic repulsion between the low pI antibody and negatively charged cell surface.
8. Differences in the frequency of germline usage are reported, and it is known that particular germline frameworks are frequently used in the human antibody repertoire [38]. Since a germline framework with high frequency is considered to be more immune tolerant compared to that with low frequency, humanized antibody with a high frequency germline framework sequence is expected to be less immunogenic.
9. An appropriate software, like GENETYX can provide the theoretical isoelectric point of a designed humanized antibody.
10. If none of the framework sequences fulfills all the requirements described above, more than one framework could be selected for humanization. For example, one framework, termed FR1A, conserves the upper hydrophobic core and structure core residues but its pI is extremely high, and the second framework, termed FR1B, conserves upper hydrophobic core residues and has a pI but does not conserve structure core residues. In this case, FR1A and FR1B could both be selected as candidate acceptor frameworks.
11. Chemical modifications, such as deamidation, isomerization, succinimide formation, methionine, and tryptophan oxidation, often lead to reduced antigen-binding activity, and might affect immunogenicity, safety, or pharmacokinetics. Such modification sites should be removed before selecting the clinical candidate.
12. The framework sequences selected for humanization could affect the risk of immunogenicity of the boundary regions. Therefore, *in silico* tools such as Epibase (Lonza Inc.), iTope/TCED (Antitope Ltd.), and EpiMatrix (EpiVax Inc.) [39–43], which can predict the presence of peptide sequences carrying T cell epitopes, could be used to predict the potential immunogenicity of designed humanized antibody variants. Although these *in silico* tools are valuable for predicting the risk of immunogenicity, it should be noted that they tend to be over-predictive.
13. Many companies, such as Life Technologies Corporation and GenScript USA Inc., provide gene design which considers

codon adaptability, mRNA structure, and various cis-elements in transcription and translation. This provides levels of production and gene synthesis that are precise and efficient in comparison to conventional methods of assembly PCR. If your laboratories cannot use these services, nucleotide sequence of human germline framework can be obtained from IMGT, VBASE, EMBL, or NCBI, and cDNA sequence could be synthesized by assembly PCR.

14. If no human constant regions of the heavy and light chains are available in your laboratories, cDNA of the human constant regions also needs to be designed and synthesized.
15. With membrane-bound antigen, the antigen-binding activity of humanized antibody variants can be analyzed by Biacore using the extracellular domain of antigens, or by cell ELISA using a cell line expressing membrane-bound antigen.
16. For Biacore analysis, prepare extracellular domain of antigen with a tag, such as His6 tag. Extracellular domain of antigen is immobilized onto a sensor chip through anti-tag antibody. Inject humanized antibody variants as the analyte and determine the antigen-binding activity. For cell ELISA, prepare an antigen-expressing cell and determine the antigen-binding activity.
17. If the antigen-binding activity of (ii) is lower than that of (iv), the loss of binding activity is caused by the VH domain of humanized antibody. Therefore, use the following process to identify which framework(s) and which amino acid(s) is responsible for the loss of binding activity.

References

1. Nishimoto N, Kishimoto T (2008) Humanized antihuman IL-6 receptor antibody, tocilizumab. *Handb Exp Pharmacol* 181:151–160
2. Buch MH, Emery P (2011) New therapies in the management of rheumatoid arthritis. *Curr Opin Rheumatol* 23:245–251
3. Tanaka T, Kishimoto T (2012) Immunotherapeutic implication of IL-6 blockade. *Immunotherapy* 4:87–105
4. Breedveld F (2011) The value of early intervention in RA—a window of opportunity. *Clin Rheumatol* 33:33–39
5. Pangalis GA et al (2001) Campath-1H (anti-CD52) monoclonal antibody therapy in lymphoproliferative disorders. *Med Oncol* 18:99–107
6. Weiner GJ (2010) Rituximab: mechanism of action. *Semin Hematol* 47:115–123
7. Scott AM, Wolchok JD, Old LJ (2012) Antibody therapy of cancer. *Nat Rev Cancer* 12:278–287
8. Reichert JM (2011) Antibody-based therapeutics to watch in 2011. *MAbs* 3:76–99
9. Schroff RW et al (1985) Human anti-murine immunoglobulin responses in patients receiving monoclonal antibody therapy. *Cancer Res* 45:879–885
10. Shawler DL et al (1985) Human immune response to multiple injections of murine monoclonal IgG. *J Immunol* 135:1530–1535
11. Boulianne GL, Hozumi N, Shulman MJ (1984) Production of functional chimaeric mouse/human antibody. *Nature* 312:643–646
12. Hwang WY, Foote J (2005) Immunogenicity of engineered antibodies. *Methods* 36:3–10
13. Jones PT et al (1986) Replacing the complementarity-determining regions in a human antibody with those from a mouse. *Nature* 321:522–525
14. Almagro JC, Fransson J (2008) Humanization of antibodies. *Front Biosci* 13:1619–1633

15. Wu H, Dall'Acqua WF (2005) Humanized antibodies and their applications. *Methods* 36:1–2
16. Tan P et al (2002) “Superhumanized” antibodies: reduction of immunogenic potential by complementarity-determining region grafting with human germline sequences: application to an anti-CD28. *J Immunol* 169:1119–1125
17. Hwang WY et al (2005) Use of human germline genes in a CDR homology-based approach to antibody humanization. *Methods* 36:35–42
18. Pelat T et al (2008) Germline humanization of a non-human primate antibody that neutralizes the anthrax toxin, by in vitro and in silico engineering. *J Mol Biol* 384:1400–1407
19. Tamura M et al (2000) Structural correlates of an anticarcinoma antibody: identification of specificity-determining residues (SDRs) and development of a minimally immunogenic antibody variant by retention of SDRs only. *J Immunol* 164:1432–1441
20. Gonzales NR et al (2004) SDR grafting of a murine antibody using multiple human germline templates to minimize its immunogenicity. *Mol Immunol* 1:863–872
21. Kashmiri SV et al (2005) SDR grafting—a new approach to antibody humanization. *Methods* 36:25–34
22. Maloney DG (2012) Anti-CD20 antibody therapy for B-cell lymphomas. *N Engl J Med* 366:2008–2016
23. Ducancel F, Muller BH (2012) Molecular engineering of antibodies for therapeutic and diagnostic purposes. *MAbs* 4:445–457
24. Igawa T et al (2011) Engineering the variable region of therapeutic IgG antibodies. *MAbs* 3:243–252
25. Strohl WR (2009) Optimization of Fc-mediated effector functions of monoclonal antibodies. *Curr Opin Biotechnol* 20:685–691
26. Greer J (1991) Comparative modeling of homologous proteins. *Methods Enzymol* 202:239–252
27. Morea V, Lesk AM, Tramontano A (2000) Antibody modeling: implications for engineering and design. *Methods* 20:267–279
28. Whitelegg NR, Rees AR (2000) WAM: an improved algorithm for modelling antibodies on the WEB. *Protein Eng Des Sel* 13:819–824
29. Marcatili P, Rosi A, Tramontano A (2008) PIGS: automatic prediction of antibody structures. *Bioinformatics* 24:1953–1954
30. Sircar A, Kim ET, Gray JJ (2009) RosettaAntibody: antibody variable region homology modeling server. *Nucleic Acids Res* 37:474–479
31. Almagro JC et al (2011) Antibody modeling assessment. *Proteins* 79:3050–3066
32. Ewert S, Honegger A, Plückthun A (2004) Stability improvement of antibodies for extracellular and intracellular applications: CDR grafting to stable frameworks and structure-based framework engineering. *Methods* 34:184–199
33. Ewert S et al (2003) Biophysical properties of human antibody variable domains. *J Mol Biol* 325:531–553
34. Honegger A, Plückthun A (2001) The influence of the buried glutamine or glutamate residue in position 6 on the structure of immunoglobulin variable domains. *J Mol Biol* 309:687–699
35. Jung S et al (2001) The importance of framework residues H6, H7 and H10 in antibody heavy chains: experimental evidence for a new structural subclassification of antibody V(H) domains. *J Mol Biol* 9:701–716
36. Honegger A et al (2009) The influence of the framework core residues on the biophysical properties of immunoglobulin heavy chain variable domains. *Protein Eng Des Sel* 22:121–134
37. Igawa T et al (2010) Reduced elimination of IgG antibodies by engineering the variable region. *Protein Eng Des Sel* 23:385–392
38. Glanville J et al (2009) Precise determination of the diversity of a combinatorial antibody library gives insight into the human immunoglobulin repertoire. *Proc Natl Acad Sci USA* 106:20216–20221
39. Van WI et al (2007) Immunogenicity screening in protein drug development. *Expert Opin Biol Ther* 7:405–418
40. Perry LC, Jones TD, Baker MP (2008) New approaches to prediction of immune responses to therapeutic proteins during preclinical development. *Drugs R&D* 9:385–396
41. Bryson CJ, Jones TD, Baker MP (2010) Prediction of immunogenicity of therapeutic proteins: validity of computational tools. *BioDrugs* 24:1–8
42. Koren E et al (2007) Clinical validation of the “in silico” prediction of immunogenicity of a human recombinant therapeutic protein. *Clin Immunol* 124:26–32
43. De Groot AS, McMurry J, Moise L (2008) Prediction of immunogenicity: in silico paradigms, ex vivo and in vivo correlates. *Curr Opin Pharmacol* 8:620–626

Chimeric Antibodies

Kohei Kurosawa, Waka Lin, and Kunihiro Ohta

Abstract

Here we describe a detailed protocol for the one-step preparation of antigen-specific human chimeric immunoglobulin G (IgG) monoclonal antibodies (mAbs) using an in vitro antibody design method referred to as the ADLib (Autonomously Diversifying Library) system. This method employs a chicken B cell line DT40-based library in which the variable regions of the Ig gene loci have been highly diversified by treatment with the histone deacetylase inhibitors. DT40 cells express both membrane-bound and secreted forms of chicken IgM. This property allows a rapid screening and selection of antibody-producing B cells from the library by using magnetic beads conjugated with any antigen of interest. To apply the ADLib system to the direct generation of human chimeric antibody, we have inserted a DNA segment coding for the constant region of human IgG into the chicken IgM heavy-chain locus of DT40 cells by homologous gene targeting. By a mechanism of alternative splicing, the resulting DT40 strain simultaneously expresses chimeric human IgG that contain the same Ig variable region sequences as the membrane-bound chicken IgM displayed at the cell surface. Application of the ADLib system to this human Ig-inserted DT40 strain enables the one-step isolation of human chimeric IgG that is specific for any antigen of interest and can be easily purified for immediate use.

Key words Chimeric antibody, Monoclonal antibody library, DT40 cell, ADLib system, Gene targeting, RNA processing, Trichostatin A (TSA)

1 Introduction

Chimerization or humanization of antibodies is a necessary process to reduce their immunogenicity when preparing monoclonal antibodies (mAbs) for therapeutic purposes. Chimeric antibodies can be generated by fairly straightforward genetic engineering, by joining the immunoglobulin (Ig) variable regions of a selected mouse hybridoma to human Ig constant regions, and be used as such or as a first stage towards further humanization [1, 2]. However, this process involves multiple steps including time-consuming genetic manipulation that has to be performed for each selected antigen-specific clone as illustrated in Fig. 1a. Chimerization by using mammalian culture cells can also induce a loss of mAb expression

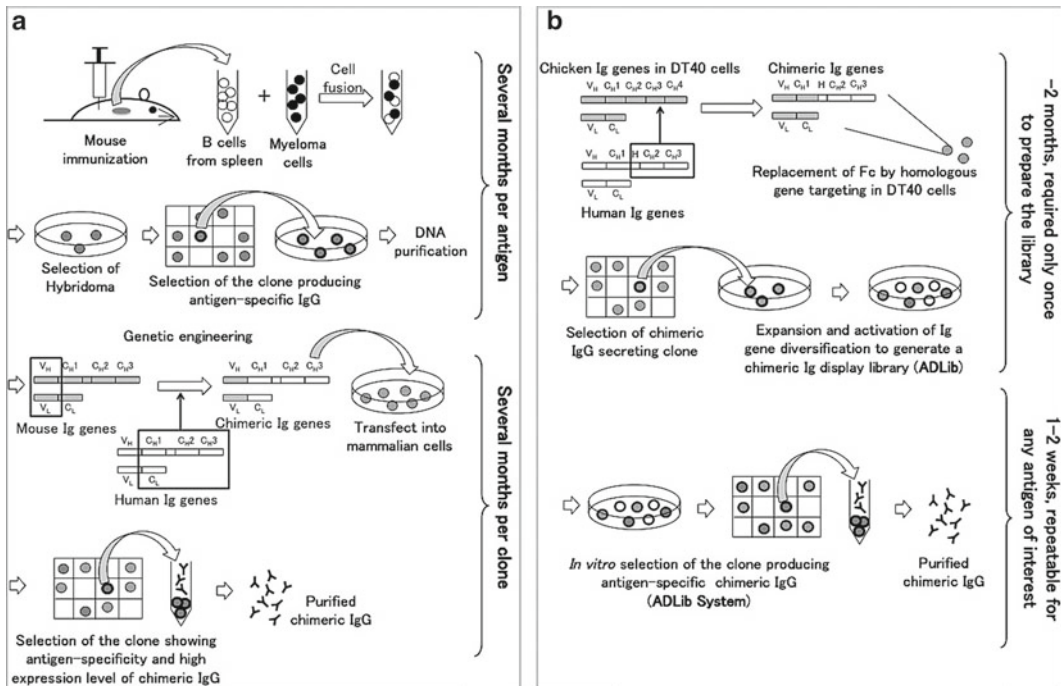

Fig. 1 (a) Schematic diagram of the conventional method to generate mAbs and the chimerization of antibodies. First, the spleen containing B cells from an immunized mouse is collected. The B cells are fused with myeloma cells to construct hybridoma and isolate a clone producing antigen-specific IgG. The DNA sequences coding mouse V_H and V_L are then isolated from the clone, as well as the DNA sequences coding human immunoglobulin constant regions from human cells. Mouse/human chimeric genes are constructed by genetic engineering and transfected into mammalian cells. Finally, the clone revealing a high level expression of chimeric IgG is selected and the IgGs are purified from the culture supernatant [6–8]. (b) Schematic diagram of the method for direct production of chimeric IgGs. A DT40 strain producing membrane-bound form chicken IgM and secreted form human chimeric IgG is constructed by gene targeting. The immunoglobulin variable genes of the transformed clone producing chimeric IgG is diversified by treatment with TSA to generate cell libraries displaying a repertoire of antibodies. Diversified libraries can be stocked for repeated later use by freezing the cells. The cells producing the antigen-specific antibodies of interest are screened and selected using antigen-conjugated magnetic beads. The selected clone is expanded and the human chimeric IgG can be directly purified from the culture supernatant

or specificity, so that repeated selection rounds of compatible candidate clones can be required until finding the best suited one. We previously developed an *in vitro* cell-based technology referred to as the “ADLib (Autonomously Diversifying Library) system,” which allows the rapid screening and isolation of DT40 cells expressing antigen-specific mAbs (in about 1 week starting from the B cell clone selection from the cell surface mAb display library) [3, 4]. In order to facilitate the generation of human chimeric antibodies, we also developed a DT40 strain with a targeted insertion of the Fc region of human IgG1 heavy chain into the chicken IgM heavy chain locus [5]. This particular construct depicted in Fig. 2a allows this cell line to coexpress secreted human chimeric IgG and

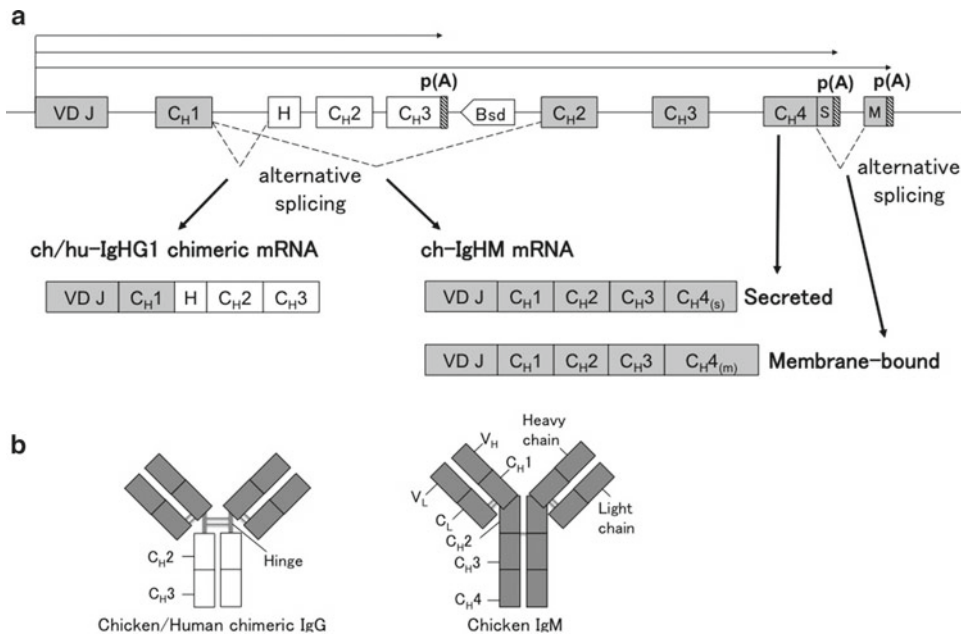

Fig. 2 (a) Map of the chicken IgHM locus with insertion of a human IgG segment. Three types of mature mRNAs are generated from an immunoglobulin heavy chain gene. (b) Schematic diagram of the antibodies coded by the constructed DT40 cells. Chicken/human chimeric antibodies are obtained by joining the Fab region of a chicken mAb, which contains the antigen-binding variable regions and a part of the human Fc regions

membrane-bound chicken IgM by alternative RNA splicing, thus keeping its ability to display mAbs on the cell surface while at the same time producing human chimeric IgG with the same variable region sequences (Fig. 2b). By combining the ADLib system with this human Ig-inserted DT40 strain (Fig. 3), we can directly select and test multiple antigen-specific human chimeric mAb candidates for any antigen of interest in minimal time. This method could therefore remarkably reduce the time and labor spent to prepare useful mAbs for various purposes, as shown in Fig. 1b by comparison to the traditional method of Fig. 1a. The present protocol describes each important step of the complete process from the genetic construction of the human chimeric IgG-producing master strain for library generation, to the selection of antigen-specific candidate clones by applying the ADLib system followed by purification of chimeric human IgG.

2 Materials

DT40 cells expressing chicken IgM on their surface.

Human total genomic DNA (extracted from any suitable human cells, e.g., human primary fibroblasts).

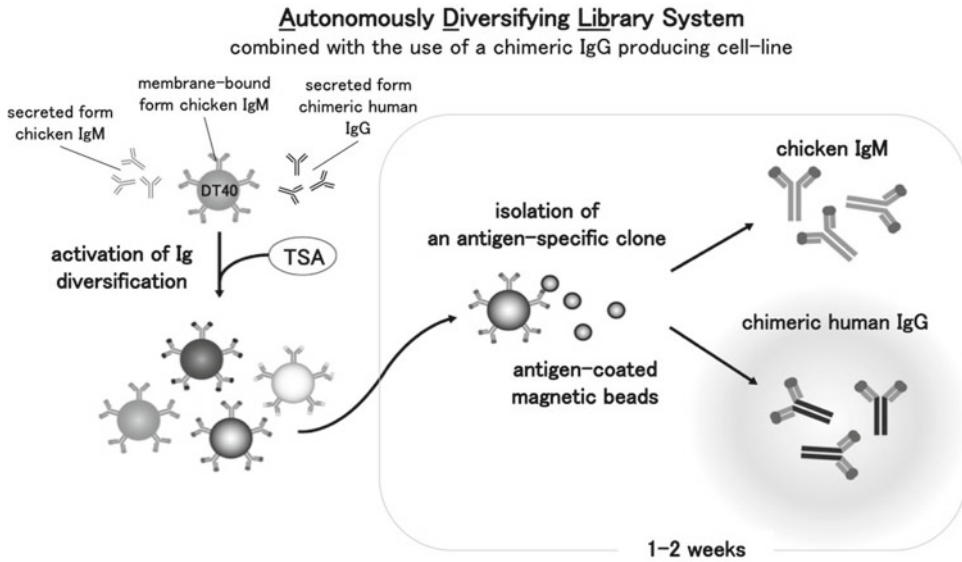

Fig. 3 Schematic diagram of the ADLib system using the DT40 cells expressing chicken/human chimeric IgG. The DT40 cells producing antigen-specific antibodies are screened using antibody-conjugated magnetic beads which are recognized by the membrane-bound form chicken IgM, and then the simultaneously expressed chimeric human IgGs can be purified from the culture supernatants of the selected clones

pCR2.1TOPO vector.

IMDM.

Fetal bovine serum.

Chicken serum.

Penicillin–Streptomycin solution.

2-Mercaptoethanol solution.

Phenol/chloroform.

Phosphate buffer saline.

Electroporation cuvette (0.4 cm).

Electroporator.

Blasticidin.

96-well flat-bottom microtiter plate.

Nitrocellulose membrane.

PBST: PBS, 0.05 % Tween 20.

Skim milk.

Horseshoe Peroxidase (HRP)-conjugated anti-human IgG-Fc antibody.

ECL reagent.

Trichostatin A (TSA).

Tosylactivated M280 Dynabead.

Dynal MPC-S.

Buffer A: 0.1 M Na-Phosphate buffer, pH 7.4.

Buffer B: PBS, 0.1 % BSA, pH 7.4.

Buffer C: 0.2 M Tris-HCl, 0.1 % BSA, pH 8.5.

Sodium azide.

Selection buffer: PBS, 1 % BSA.

U-shaped bottom maxisorp immunoplate.

Tween 20.

Horseshoe Peroxidase (HRP)-conjugated anti-chicken IgM antibody.

TMB+.

0.5 M H₂SO₄.

Microplate reader.

AIM-V.

Protein G affinity chromatography column.

3 Methods

3.1 Construction of the Chimeric Ig Knock-In Vector

1. Amplify the constant region of the chicken IgM heavy chain locus (hereafter referred as to chicken IgHM, about 9 kb between the exons C_H1 and C_H3) using genomic DNA from DT40 as a PCR template. The resultant PCR fragments are then inserted into pCR2.1TOPO vector, according to the protocol by the manufacturer. Note that direct amplification might require some technical tips (*see* **Note 1**).
2. Amplify the constant region of human IgG1 heavy chain locus (hereafter referred as to human IgHG1-Fc, ~2 kb region from 340 bp upstream of the 5' end of hinge region to 670 bp downstream of the polyadenylation site of the human IgG1 locus) by PCR using human genomic DNA as a template. The amplified DNA is inserted into pCR2.1TOPO vector.
3. Insert a Blasticidin S resistance (bsr) marker gene driven by a chicken β -actin promoter into the downstream region of human IgHG1-Fc with an opposite orientation to human IgHG1-Fc.
4. Using appropriate restriction enzymes, excise the amplified DNA fragment containing the full-length IgHG1-Fc and the bsr marker cassette.
5. Insert the above-mentioned DNA fragment into *Bse*RI-generated blunt ends introduced in an intronic region between exons C_H1 and C_H2 of chicken IgHM.
6. Amplify by cloning in *E. coli* and extract large amount of the DNA plasmid (e.g., 100 μ g).

3.2 Cell Culture

Culture DT40 cells in IMDM supplemented with 10 % fetal bovine serum, 1 % chicken serum, 50 U/ml penicillin-50 µg/ml streptomycin and 55 µM 2-mercaptoethanol at 39.5 °C in 5 % CO₂ incubator. Change the medium every 1 or 2 days to maintain the cell density between 2×10^5 and 1.5×10^6 cells/ml.

3.3 Construction of a DT40 Strain Producing Human Chimeric IgG

1. Linearize 50 µg of the vector plasmid DNA with an appropriate restriction enzyme, which can introduce a single cut in vector segments.
2. Purify the DNA segments with phenol/chloroform and followed by ethanol precipitation.
3. Resuspend the DNA pellet in 800 µl of sterilized PBS and keep it on ice.
4. Harvest 1×10^7 DT40 cells and wash them in ice-cold PBS.
5. Add the DNA solution into the cell suspension and transfer to the electroporation cuvette.
6. Incubate the cuvette on ice for 10 min.
7. Vortex briefly and perform electroporation at 25 µF and 550 V.
8. Quick chill the cuvette on ice and stand for 10 min.
9. Transfer the cells in 20 ml medium and incubate at 37 °C and 5 % CO₂ for 24 h.
10. The cells are then harvested and resuspended into 80 ml of selection medium supplemented with blasticidin (final concentration: 15 µg/ml).
11. Dispense the cell suspension into four 96-well plates (200 µl in each well).
12. Incubate at 39.5 °C and 5 % CO₂. Drug-resistant colonies are visible after approximately 7 days.

3.4 Screening and Verification of Target Integration by Dot Blot Analysis

The population of homologous insertion is expected to be low (around 0.2 %) (*see Note 2*). Therefore, a primary screening of transformed clones is performed by dot blot analysis as a convenient method to detect clones secreting human IgG into the culture medium.

1. Remove 2 µl of culture supernatant from each well containing a single colony and transfer them onto a nitrocellulose membrane.
2. Block the membrane in PBST containing 5 % skim milk at room temperature for 1 h.
3. Wash the membrane twice in PBST for 5 min.
4. Incubate with HRP-conjugated anti-human IgG-Fc antibody dissolved in PBTS containing 0.1 % skim milk for 1 h.
5. Wash the membrane five times in PBST (15 min \times 1, 5 min \times 4).

6. Incubate with ECL reagent for 1 min and detect the signals by image visualizer.
7. Transfer the colony corresponding to a dot with a positive signal in culture medium and expand the culture.
8. Verify the correct insertion of the construct by, e.g., extraction of total RNA and RT-PCR to confirm the expression of both chicken and chimeric IgG.

3.5 Preparation of Diversified DT40 Cell Library

DT40 cells secreting chimeric human IgG are treated with Trichostatin A (TSA, at final concentration of 8.3–10 nM) for more than 6 weeks following the method described in a previous publication [4]. The cell density should be lower than 1.5×10^6 cells/ml. The TSA-containing medium should be changed every day.

3.6 Preparation of Antigen-Conjugated Magnetic Beads [4]

1. Add 200 μ l of Tosylactivated M280 Dynabeads into a 1.5-ml tube. Place the tube on Dyal MPC-S for 2 min.
2. Discard the supernatant and detach the tube from Dyal MPC-S.
3. Resuspend the beads in 400 μ l of buffer A containing 0.3 mg/ml of the antigen of interest.
4. Incubate at 37 °C for 16 h with gentle rotation.
5. Insert the tube on Dyal MPC-S for 2 min.
6. Discard the supernatant and remove the tube from Dyal MPC-S.
7. Resuspend the beads in 400 μ l of buffer B and set the tube on Dyal MPC-S for 2 min.
8. Discard the supernatant and detach the tube from Dyal MPC-S.
9. Resuspend the beads in 400 μ l of C and incubate at 37 °C for 4 h.
10. Set the tube on Dyal MPC-S for 2 min.
11. Discard the supernatant and detach the tube from Dyal MPC-S.
12. Resuspend the beads in 400 μ l of buffer B containing 0.02 % sodium azide. Note that antigen-conjugated beads should be prepared prior to the selection described below.

3.7 Selection of Cells Using Magnetic Beads

1. Harvest 1×10^8 cells of the diversified library.
2. Wash the cells twice in 5 ml of selection buffer.
3. Resuspend the cells in 1 ml of selection buffer.
4. The cells are transferred into 1.5-ml tube and collected by centrifugation.

5. During centrifugation, prepare the magnetic beads solution.
 - (a) Add 5 μ l of the antigen-conjugated magnetic beads suspension into 1 ml of selection buffer in a 1.5-ml tube. Resuspend the cells by gentle pipetting.
 - (b) Set the tube on Dynal MPC-S for 2 min.
 - (c) Discard the supernatant and detach the tube from Dynal MPC-S.
 - (d) Resuspend the beads in 1 ml of selection buffer.
 - (e) Repeat **step 5b–d** once again.
6. Mix the cell pellet from **step 4** in the beads suspension from **step 5** in 1.5 ml tube.
7. Incubate at 4 °C with gentle rotation for 30 min.
8. Spin down the liquid briefly and set the tube on Dynal MPC-S for 2 min.
9. Discard the supernatant and detach the tube from Dynal MPC-S.
10. Suspend the pellet in 1 ml of selection buffer by gentle pipetting.
11. Repeat **steps 8–10** four times to wash the pellet.
12. During **step 11**, prepare 30 ml of prewarmed medium in 50 ml tube.
13. Place the tube on Dynal MPC-S for 2 min and discard the supernatant.
14. Resuspend the pellet by gentle pipetting in 0.5 ml of selection buffer.
15. Add the suspension to the medium prepared in **step 12**, mix well by pipetting.
16. Plate the cells into 96-well plates, placing 300 μ l in each well.
17. Incubate at 39.5 °C and 5 % CO₂. Colonies are visible after about 7 days (*see Note 3*).

3.8 Screening of the Clones by ELISA

1. Add 100 μ l of PBS containing 5 μ g/ml of antigen into the wells of 96-well immunoplates. Prepare another immunoplate absorbed with a different protein as a negative control. This control enables us to eliminate clones producing antibodies with nonspecific binding.
2. Incubate at 4 °C overnight.
3. Discard the solution. The plate is then blocked with 200 μ l of PBS containing 1 % BSA.
4. Incubate at room temperature for 30 min.
5. Discard the solution.

6. Wash three times with 200 μ l of PBS containing 0.05 % Tween 20.
7. Add 100 μ l of the culture supernatant from the cells expanded in 96-well plates.
8. Incubate at room temperature for 1 h.
9. Discard the supernatants and wash five times with 200 μ l of PBS containing 0.05 % Tween 20.
10. Add 100 μ l of PBS containing 1 % BSA with HRP-conjugated anti-chicken IgM antibody or anti-human IgG-Fc antibody.
11. Incubate at room temperature for 1 h.
12. Discard the contents.
13. Wash five times with 200 μ l of PBS containing 0.05 % Tween 20.
14. Add 100 μ l of TMB+ and incubate at room temperature for ~3 min.
15. Add 100 μ l of 0.5 M H₂SO₄ to stop the reaction. The reaction should be terminated before reaching a plateau.
16. Measure the optical density at 450 nm with a microplate reader.
17. Subtract the background signal of the medium from the signals of each well in the plates.
18. Calculate the antigen/negative control ratios.
19. Select clones that exhibit a high ratio (e.g., >10).
20. Expand the selected clone in 10 ml then 100 ml culture medium (50 ml \times 2 in 30 cm dish) to prepare cells for the next step.

3.9 Purification of Chimeric IgG

1. Harvest 1×10^8 DT40 cells and transfer into 30 cm culture dishes with 50 ml of AIM-V medium (for a high IgG production and avoiding the contamination of unwanted IgG of serum-containing culture media).
2. Incubate at 39.5 °C and 5 % CO₂ for 48 h.
3. Spin down the cells and filtrate the culture supernatant with a 0.22 μ m filter membrane.
4. Purify the chimeric IgG with a protein G affinity chromatography column (1 ml size) according to the protocol of the manufacturer.
5. Finally, elute the chimeric IgG in 3 ml elution buffer. The expected concentration is around 30 μ g/ml and the purified antibody is ready for use in various applications (e.g., immunostaining, flow-cytometry, and ELISA).

4 Notes

1. Direct amplification of the chicken IgHM constant region (about 9 kb) can be difficult because of intronic repeat sequences and GC-rich regions. If necessary, the region for amplification can be divided into two parts and PCR amplified by Expand Long Template PCR System (Roche) individually, followed by ligation at the *PmI* restriction site in exon C_H2.
2. Homologous gene targeting frequency at the immunoglobulin constant region is very low (~0.2 %) compared to other loci (~50 %), possibly owing to large tandem repeats in the introns.
3. If too many colonies appear (>100 per plate) in Subheading 3.7, the cell number for selection can be reduced (e.g., 1×10^7 cells).

References

1. Liu AY, Robinson RR, Murray ED Jr, Ledbetter JA, Hellstrom I, Hellstrom KE (1987) Production of a mouse–human chimeric monoclonal antibody to CD20 with potent Fc-dependent biologic activity. *J Immunol* 139: 3521–3526
2. Morrison SL, Johnson MJ, Herzenberg LA, Oi VT (1984) Chimeric human antibody molecules: mouse antigen-binding domains with human constant region domains. *Proc Natl Acad Sci USA* 81:6851–6855
3. Seo H, Masuoka M, Murofushi H, Takeda S, Shibata T, Ohta K (2005) Rapid generation of specific antibodies by enhanced homologous recombination. *Nat Biotechnol* 23:731–735
4. Seo H, Hashimoto S, Tsuchiya K, Lin W, Shibata T, Ohta K (2006) An ex vivo method for rapid generation of monoclonal antibodies (ADLib system). *Nat Protoc* 1:1502–1506
5. Lin W, Kurosawa K, Murayama A, Kagaya E, Ohta K (2011) B-cell display-based one-step method to generate chimeric human IgG monoclonal antibodies. *Nucleic Acids Res* 39:e14
6. de StGroth SF, Scheidegger D (1980) Production of monoclonal antibodies: strategy and tactics. *J Immunol Methods* 35:1–21
7. Kohler G, Milstein C (1975) Continuous cultures of fused cells secreting antibody of predefined specificity. *Nature* 256:495–497
8. Kohler G, Milstein C (1976) Derivation of specific antibody-producing tissue culture and tumor lines by cell fusion. *Eur J Immunol* 6: 511–519

Recombinant Genetic Libraries and Human Monoclonal Antibodies

Jarrett J. Adams, Bryce Nelson, and Sachdev S. Sidhu

Abstract

In order to comprehensively manipulate the human proteome we require a vast repertoire of pharmacological reagents. To address these needs we have developed repertoires of synthetic antibodies by phage display, where diversified oligonucleotides are used to modify the complementarity-determining regions (CDRs) of a human antigen-binding fragment (Fab) scaffold. As diversity is produced outside the confines of the mammalian immune system, synthetic antibody libraries allow us to bypass several limitations of hybridoma technology while improving the experimental parameters under which pharmacological reagents are produced. Here we describe the methodologies used to produce synthetic antibody libraries from a single human framework with diversity restricted to four CDRs. These synthetic repertoires can be extremely functional as they produce highly selective, high affinity Fabs to the majority of soluble human antigens. Finally we describe selection methodologies that allow us to overcome immuno-dominance in our selections to target a variety of epitopes per antigen. Together these methodologies allow us to produce human monoclonal antibodies to manipulate the human proteome.

Key words Synthetic antibodies, Phage display, Synthetic libraries, Protein engineering

1 Introduction

With a complete human genome DNA sequence, we are now challenged by the task of developing tools to manipulate the proteome encoded by these ~20,500 genes [1]. Such a task requires a vast repertoire of pharmacological reagents in order to comprehensively manipulate human cellular programming. As nearly every gene can be regulated by protein interactions, development of protein affinity reagents that manipulate cell biology has been the basis of much research. Antibodies, in particular, have been the major focus of this intellectual spotlight. Like small molecules, they can be used to target almost any individual protein with a solvent accessible surface. Antibodies, however, frequently outperform small molecules due to their large binding surface that allows for high

affinity and exquisite specificity. Also, antibodies are integral components of our physiology and humoral immunity. As high concentrations of human isotypes are well tolerated in the human periphery, antibodies can be designed to elicit (or avoid) natural humoral responses critical for certain therapeutic functions. The development of human monoclonal antibodies against human antigens will therefore continue to play a pivotal role in a comprehensive pharmacological toolbox to explore human cellular life and disease.

Typically, hybridoma technologies are used to produce antibodies that target human antigens. This involves a number of cellular manipulations and animal husbandry as host mammals (typically murine) are injected with antigen, amplified B cell populations are harvested from the animal's spleen, splenocytes are fused with an immortalized B cell line to form hybridomas, and finally, fused clones are then screened for antigen binding by ELISA [2]. While a proven approach for antibody development, hybridoma technology is an expensive and laborious means to create diverse sets of high-quality monoclonal antibodies to an antigen set as large as the human proteome. Furthermore the hybridoma technology can be limited by the constraints of the mammalian immune responses that produce the antibodies and their B cells. One common problem with natural immune responses is self-tolerance within the peripheral B cell populations [3]. This lack of autoimmune cells typically makes it difficult to raise antibodies to proteins highly similar to the host proteome, because B cell populations are devoid of responders or responders are repressed by peripheral tolerance mechanisms. Furthermore, it is also clear that targeting multiple unique epitopes of a single antigen can provide a variety of unique antigen responses and cellular outcomes [4]. However identifying multiple unique epitopes per antigen from antibody repertoires remains a challenge, as antibody responses are often skewed towards immuno-dominant features of protein surface [5]. Finally, antibodies recovered from different species must be "humanized" before being used as potential therapeutics. This task is not trivial as grafting the antigen recognition fragments onto a human antibody scaffold can perturb the antibody's recognition and functional properties in unpredictable ways [6].

We therefore sought new technologies that could potentially produce antibody-based pharmacological reagents to the human proteome and allow us to address the major caveats of hybridoma technologies. One attractive alternative is "synthetic" human antibody repertoires produced by a technology called phage display. The unbiased selection from libraries built with a single Fab scaffold allows us to circumvent a number of caveats of hybridoma technology. For instance synthetic libraries are not edited by an animal's adaptive immune system. This allows us to produce Fabs that would be eliminated from an animal's periphery due to

tolerance mechanisms that deplete self-reactive B cells. Furthermore, controlled *in vitro* selections allow us to evade immuno-dominance that arises in any antibody repertoire. Together these advantages allow us to target a more comprehensive set of epitopes per antigen and a larger fraction of the human proteome compared to a hybridoma approach. Finally, human antibody fragments can be used as scaffolds for phage display libraries, obviating any further humanization for therapeutic development.

After more than two decades of antibody phage display, this technology has generated or improved numerous antibodies considered challenging by traditional methods [7–9]. What has made phage display so attractive to scientists is that, using standard molecular biology techniques, one can build highly diverse libraries that will produce functional antibodies from controlled *in vitro* selections. These “test tube” selections allow us to manipulate parameters that simply could not be done in an animal, adding a higher level of sophistication to the antibodies produced by this methodology. By avoiding an animal immune system, the rate at which antibodies are produced, characterized, and sequenced is greatly enhanced. Since the sequence of each antibody is encoded in the encapsulated phage DNA, affinities and specificities of an antibody can be fine-tuned, post selection, by further genetic manipulations and selections. Furthermore, the recombinant nature of the technology allows for rapid reformatting of phage-displayed antibody fragments for the production of full-length immunoglobulins, Fabs, or scFvs (Fig. 1). Phage displayed antibodies can be easily integrated into virtually all monoclonal technologies and applications, and thus, they provide a streamlined approach to the production of human monoclonal antibodies.

Early phage display libraries consisted of natural antibody repertoires amplified from human tissues and transferred into phage display vectors [10]. While this approach to library construction remains common and useful for many applications, these repertoires are still limited to the diversity provided by a natural adaptive immune system (human or otherwise). Exhaustive structure and function studies of antibodies and immuno-fragments have shown the molecular basis of antigen recognition that has evolved in the majority of mammalian systems (Fig. 1). An IgG is comprised of two antigen-binding fragments (Fabs) formed by covalent association of a heavy chain (HC) and a light chain (LC). Furthermore the HC is covalently associated to a second identical HC to form a third receptor-binding fragment (Fc), and this association also serves to dimerize the two antigen-binding sites to produce a bivalent avidity effect. The association of the LC and HC brings together six complementarity-determining region (CDR) loops that protrude from the variable Ig domains of the Fabs. Each of the six loops corresponds to regions of V(D)J genes where CDRs L1, L2, H1, and H2 are encoded in the V genes and

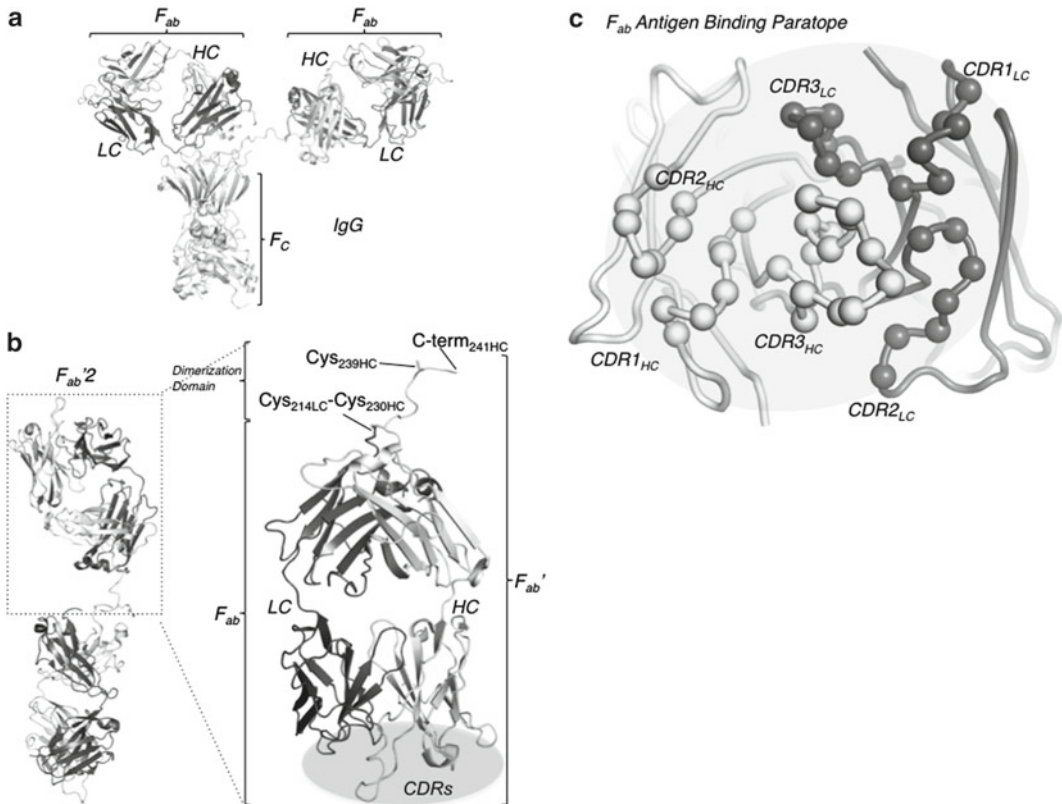

Fig. 1 Antibody structure. **(a)** Ribbon structure of a full human HIV neutralizing IgG (pdb accession 1HZH). Antigen-binding fragments (Fab) and receptor-engaging fragment (Fc) are indicated. **(b)** Ribbon structure of the Fab'2 fragment of an IgG. *Inset* is the structure of the Fab' monomer with intermolecular disulfides indicated. **(c)** Cartoon depiction of a Fab paratope where the residues encoding the complementarity determining regions (CDRs) of the HC and LC are shown as *spheres*. The LC is depicted in *gray* and HC is depicted in *white*

CDRs L3 and H3 are encoded by junctions of V-J genes or V-D-J genes respectively, which fuse during somatic recombination. Each individual in a population produces a unique set of antibody specificities by diversifying the amino acid chemistries encoded in these six CDR loops. Fusing different combinations of V, D and J genes, and pairing different HC and LC together creates an enormous combinatorial diversity that allows us to recognize nearly any foreign macromolecule. While V(D)J recombination dramatically alters the structures and flexibility of the variable CDR loops, the general folds of the variable Ig domains are only slightly influenced by CDR diversity [11]. These observations suggest that a single V_H and V_L framework could likely accommodate an array of CDR chemistries and therefore recognition features. Using this knowledge we have begun experimenting with antibody-based repertoires that are no longer constrained by frameworks of an evolved adaptive immune system.

Synthetic Fab libraries were developed by engineering DNA oligonucleotides that precisely modify the genetic determinants of the CDRs of human V_H and V_L domains within a single Fab framework. These oligonucleotides were used to amplify genetic variants of human Fab fused to a phage coat protein encoded in a phagemid vector. The single human scaffold was selected to ensure the stability of variants, to simplify sub-cloning, and to streamline any modifications required for drug, radioisotope, or viral conjugation. Somewhat surprisingly, given the complexity of evolved immune systems, modifying just the CDRs of a single human Fab framework produced libraries that yielded highly functional Fabs capable of recognizing most protein antigens [12–16]. Remarkably, the antibody recognition system could be further simplified as diverse antibody functions were produced when amino acid diversity is introduced into just four of the six CDR loops in an antibody paratope (Fig. 3b). Most surprising, however, was the finding that we could restrict amino acid chemical diversity in these CDR loops without compromising recognition function [17–20], and in the extreme case, we have shown that a binary code of tyrosine and serine is sufficient for generating antigen-binding sites capable of recognizing diverse proteins [21]. Due to the transformation efficiency of host strains of *Escherichia coli* that produce phage, the number of unique antibodies produced in a single synthetic phage pool ($>10^{10}$ unique sequences) can rival or exceed those of the human periphery [22]. This allows our synthetic repertoires the same or better combinatorial advantage, at least in numbers, as created by V(D)J recombination in natural mammalian systems. Synthetic phage systems are capable of producing affinity reagents that perform as well, if not better, than antibodies derived from the hybridoma technology, but in a much more controlled and rapid manner.

In this chapter we present some of our most recent advancements in antibody phage display methodologies [23–26] that produce highly functional Fab libraries as well as selection strategies to improve the number of targeted epitopes per antigen, in order to produce comprehensive pharmacological tools to the human proteome.

2 Materials

1. 0.2-cm gap electroporation cuvette.
2. 1.0 M Tris base, pH 11.
3. 1.0 mM Hepes, pH 7.4 (4.0 ml of 1.0 M Hepes, pH 7.4 in 4.0 L of ultrapure irrigation USP water, filter sterilize).
4. 10% (v/v) ultrapure glycerol (100 ml ultrapure glycerol in 900 ml ultrapure irrigation USP water, filter sterilize).
5. 10 mM ATP.

6. 10× TM buffer (0.1 M MgCl₂, 0.5 M Tris, pH 7.5).
7. 100 mM dNTP mix (solution containing 25 mM each of dATP, dCTP, dGTP, dTTP).
8. 96-well Maxisorp immunoplates.
9. 96-well round bottom plate.
10. 100 mM HCl.
11. 100 mM dithiothreitol (DTT).
12. 2YT medium (10 g bacto-yeast extract, 16 g bacto-tryptone, 5 g NaCl. Add water to 1.0 L; adjust pH to 7.0 with NaOH; autoclave.)
13. 2YT/carb/cmp medium (2YT, 100 µg/ml carbenicillin, 5 µg/ml chloramphenicol).
14. 2YT/carb/kan medium (2YT, 100 µg/ml carbenicillin, 25 µg/ml kanamycin).
15. 2YT/carb/kan/uridine medium (2YT, 100 µg/ml carbenicillin, 25 µg/ml kanamycin, 0.25 µg/ml uridine).
16. 2YT/carb/KO7 medium (2YT, 100 µg/ml carbenicillin, 10¹⁰ M13KO7-phage/ml).
17. 2YT/tet medium (2YT, 10 µg/ml tetracycline).
18. 2YT/carb/tet medium (2YT, 100 µg/ml carbenicillin, 10 µg/ml tetracycline).
19. 2YT/carb/tet/KO7 (2YT, 100 µg/ml carbenicillin, 10 µg/ml tetracycline, 10¹⁰ M13KO7-phage/ml).
20. 2YT/kan medium (2YT, 25 µg/ml kanamycin).
21. 2YT/kan/tet medium (2YT, 25 µg/ml kanamycin, 10 µg/ml tetracycline).
22. 2YT top agar (16 g tryptone, 10 g yeast extract, 5 g NaCl, 7.5 g granulated agar. Add water to 1.0 L and adjust pH to 7.0 with NaOH, heat to dissolve, autoclave).
23. Bovine Serum Albumin (BSA).
24. ECM-600 electroporator.
25. *E. coli* CJ236 (New England Biolabs, Beverly, MA).
26. *E. coli* SS320 (Lucigen, Middleton, WI).
27. *E. coli* One Shot® OmniMAX™ 2 T1R (Invitrogen, Grand Island, NY).
28. LB/kan plates (LB agar, 25 µg/ml kanamycin).
29. LB/carb plates (LB agar, 50 µg/ml carbenicillin).
30. LB/tet plates (LB agar, 5 µg/ml tetracycline).
31. M13KO7 helper phage (New England Biolabs, Ipswich, MA).

32. Magnetic stir bars (2 in.) soaked in ethanol.
33. Phosphate-buffered saline (PBS) (137 mM NaCl, 3 mM KCl, 8 mM Na₂HPO₄, 1.5 mM KH₂PO₄. Adjust pH to 7.2 with HCl, autoclave.)
34. PBST, PBS, 0.05 % Tween 20.
35. PEG/NaCl (20 % PEG-8000 (w/v), 2.5 M NaCl. Mix and filter sterilize).
36. QIAprep Spin M13 Kit (Qiagen, Valencia, CA).
37. QIAquick Gel Extraction Kit (Qiagen, Valencia, CA).
38. SOC medium (5 g bacto-yeast extract, 20 g bacto-tryptone, 0.5 g NaCl, 0.2 g KCl. Add water to 1.0 L and adjust pH to 7.0 with NaOH, autoclave; add 5.0 ml of autoclaved 2.0 M MgCl₂ and 20 ml of filter sterilized 1.0 M glucose.)
39. Superbroth medium (12 g tryptone, 24 g yeast extract, 5 ml glycerol; add water to 900 ml, autoclave, add 100 ml of autoclaved 0.17 M KH₂PO₄, 0.72 M K₂HPO₄).
40. Superbroth/tet/kan medium (Superbroth medium, 10 µg/ml tetracycline, 25 µg/ml kanamycin).
41. T4 polynucleotide kinase (New England Biolabs, Beverly, MA).
42. T4 DNA ligase (New England Biolabs, Beverly, MA).
43. T7 DNA polymerase (New England Biolabs, Beverly, MA).
44. TAE buffer (40 mM Tris-acetate, 1.0 mM EDTA; adjust pH to 8.0; autoclave).
45. TAE/agarose gel (TAE buffer, 1.0 % (w/v) agarose, 1:5,000 (v/v) 10 % ethidium bromide).
46. Ultrapure irrigation USP water.
47. Uridine (0.25 mg/ml in water, filter sterilize).
48. Ultrapure glycerol.

3 Methods

We present optimized protocols for the construction of phage-displayed libraries encoding >10¹⁰ unique Fab variants (Figs. 1 and 2). A parental Fab framework is displayed using a phagemid (Fig. 2) that is genetically modified to introduce the appropriate diversity into the CDRs (Fig. 3). For these methods we use the Fab' of the human IgG clone HP153 as our template scaffold. The HP153 clone recognizes a bacterial maltose binding protein and is extremely stable and amenable to synthetic modifications of the CDR loops (Fig. 2). We choose the Fab' fragment to allow for covalent assembly of Fab'2 dimers on phage, which mimic the IgG

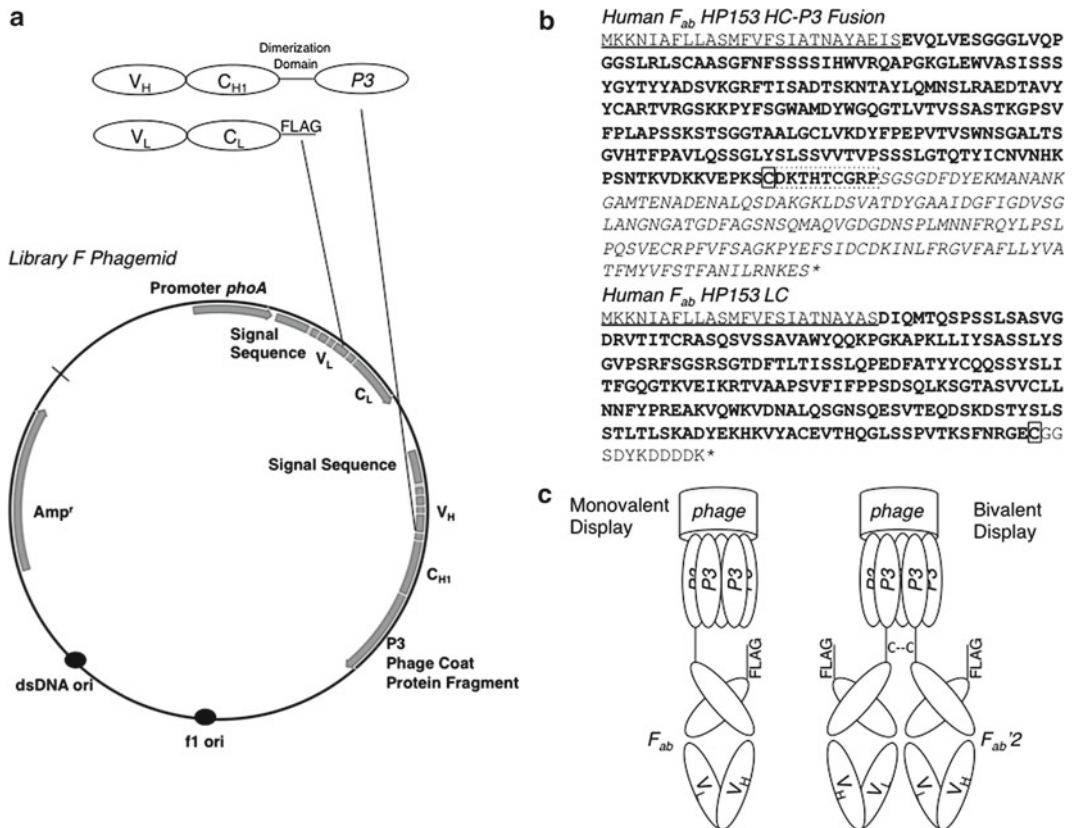

Fig. 2 Fab' encoded by phagemid for phage display. **(a)** Expression of a bicistronic message encoding the light chain (V_L - C_L) and the variable and first constant domains of the heavy chain (V_H - C_{H1}) fused to a truncated gene III coat protein is required for Fab-phage display. N-terminal secretion signals direct the proteins to the periplasm, where light and heavy chains associate to form Fabs. The phagemid also contains origins of single-stranded ($f1$ ori) and double-stranded (dsDNA ori) DNA replication, as well as a selectable marker (Amp^r) that confers resistance to carbenicillin. **(b)** Amino acid sequence of the human HP153 Fab. Signal sequences are *underlined*, Fab' coding sequences are in *bold*, the P3 fragment is in *italics*, cysteines that form interchain disulfides between the HC and LC are *boxed*, and the dimerization domain is shown in a *dashed box*. **(c)** Monovalent Fab (*left*) and bivalent Fab'2 (*right*) display arrangements on phage particles

avidity (Figs. 1 and 2). This genetic library is then transformed into *E. coli* SS320 and coinfecting with M13KO7 helper phage to produce phage particles (Fig. 3). Each initial phage particle produced could potentially display a unique Fab specificity encoded by the genetically modified phagemid encapsulated in the phage particle. These phage particles displaying Fabs can then be rapidly isolated from large complex phage populations by in vitro selections with antigens of interest (Fig. 4), and the encapsulated DNA can be sequenced to decode the diversified CDRs.

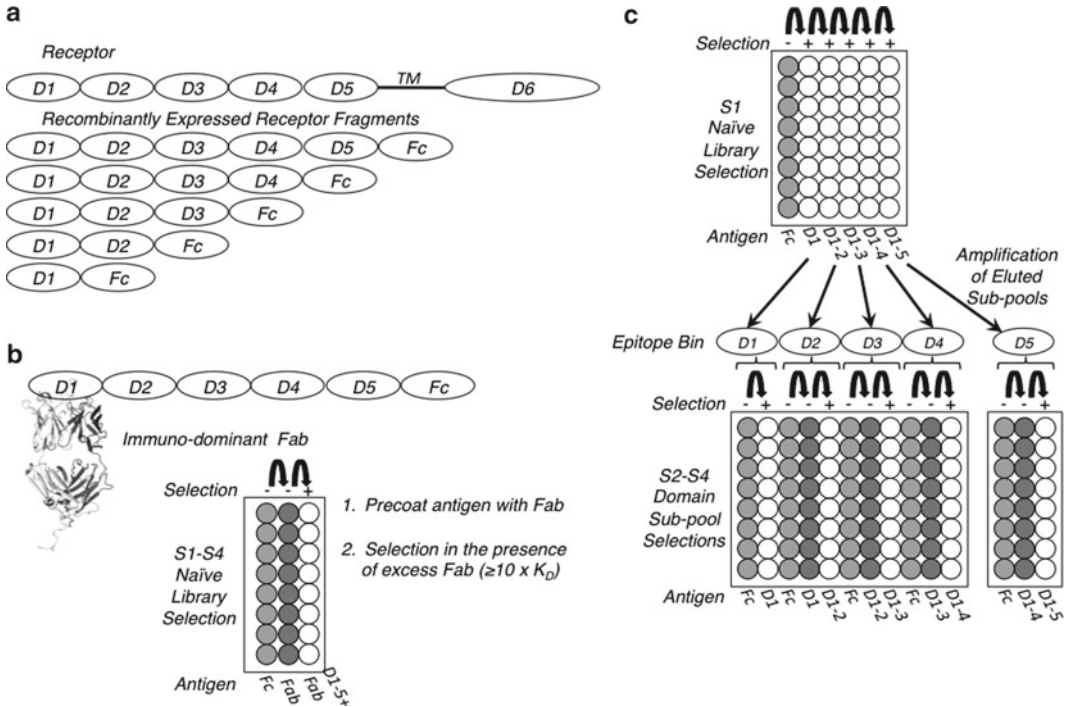

Fig. 4 Selection strategies to avoid immuno-dominance. **(a)** The domain architecture of a hypothetical human receptor with five distinct extracellular domains (D1–D5), a single-pass transmembrane region and an intracellular domain (D6). **(b)** A schematic describing a selection strategy (S1–S4) to avoid immuno-dominant responses from a synthetic library by blocking the immuno-dominant epitope with excess Fab/IgG before and during selections. **(c)** A schematic describing domain exclusion strategy to produce Fabs from synthetic libraries based on protein domain bins. Strategic negative selections are used to exclude certain domain interactions from phage pools while positively selecting for interactions on individual domains

open reading frames are under the control of the inducible alkaline phosphatase promoter (PphoA) while our scFv and V_H domain libraries are controlled by the IPTG-inducible promoter (Ptac). Importantly, the PphoA or Ptac promoters are “leaky,” and thus, are not completely repressed during phage production, allowing for low expression of the Fab-P3 fusion genes in the absence of limiting phosphate or IPTG respectively.

3.2 Library Construction

By using optimized procedures [27, 28, 31, 32] that are based on the classical oligonucleotide-directed mutagenesis method of Kunkel et al. [30], very large phage-displayed antibody repertoires (>10¹⁰ members) can be constructed quite rapidly. Importantly, the method is scalable and can be used to mutate up to four independent regions concurrently with very high efficiency. First, a *dut/ung^r* *E. coli* host is used to propagate phage encapsulating uracil-containing ssDNA (dU-ssDNA) template to which mutagenic oligonucleotides are annealed. “Stop templates” contain

stop codons in the CDRs and ensure that only mutated antibodies are displayed, as the parental stop template will fail to express a full-length Fab-P3 fusion protein. Residual template clones are therefore eliminated from the phage pools during selections.

Diversity within a Fab library can be designed by using mutagenic oligonucleotides that contain mixed bases at particular positions to produce sets of degenerate codons. Alternatively, finer control of codon usage can be achieved by using oligonucleotides synthesized from sets of trinucleotides. By choosing particular codons for specific amino acids, we biased the CDR amino acids to those that are commonly found in natural antibodies [15, 16] or are particularly well suited for antigen recognition [10, 14]. Annealed mutagenic oligonucleotides to the HP153 du-ssDNA template serve to prime synthesis of a complementary DNA strand forming a synthetic daughter strand lacking uracil. A ligase then fuses the synthesized DNA fragments to form covalently closed circular double-stranded heteroduplex DNA (CCC-dsDNA) (Fig. 3). The heteroduplex DNA is then electroporated into a highly competent strain of *dut⁺/ung^r* *E. coli*, SS320, where the synthesized strand is preferentially amplified compared to the template strand.

Transformation into an *E. coli* host results in phagemid replication as a double-stranded plasmid. Upon coinfection with helper phage, single-stranded DNA (ssDNA) replication is initiated and phagemid ssDNA is packaged into phage particles containing phagemid-encoded protein, thereby providing physical linkage between the phenotype of the Fab and the encoding phagemid genotype. Helper phage, such as M13KO7, provides all proteins necessary for assembly of phage particles with some phagemid-encoded P3-fusion protein incorporated. These phage particles produced by infected cells make up both the genetic barcode and interaction readout of the Fab library as the host *E. coli* cells are never introduced to antigens during selections.

3.2.1 Purification of dU-ssDNA Template

Library construction mutagenesis efficiency depends on template purity; therefore the use of highly pure dU-ssDNA is essential for successful library construction. By using a modified Qiagen QIAprep Spin M13 Kit protocol for dU-ssDNA purification, at least 20 µg of dU-ssDNA for a phagemid with medium copy number (e.g., pBR322 backbone) will be isolated, which is sufficient for the construction of one library of $>10^{10}$ members.

1. From a fresh LB/carb plate, pick a single colony of *E. coli* CJ236 (or another *dut⁺/ung^r* strain) containing the appropriate phagemid into 1 ml 2YT medium supplemented with M13KO7 helper phage (10^{10} pfu/ml) and appropriate antibiotics to maintain the host F' episome and the phagemid. For example, 2YT/carb/cmp medium contains carbenicillin to select for

phagemids and chloramphenicol to select for the F' episome of *E. coli* CJ236.

2. Shake at 200 rpm and 37 °C for 2 h before addition of kanamycin (25 µg/ml) to select for clones coinfecting with MI3KO7 (which carries a kanamycin resistance gene).
3. Shake at 200 rpm and 37 °C for another 6 h and transfer the culture to 30 ml 2YT/carb/kan/uridine medium.
4. Shake 20 h at 200 rpm and 37 °C.
5. Pellet bacterial cells by centrifuging for 10 min at 15,000 rpm and 4 °C in a Sorvall SS-34 rotor (27,000×*g*). Transfer the phage-containing supernatant to a new tube containing 1/5 final volume of PEG/NaCl and incubate for 5 min at room temperature.
6. Centrifuge 10 min at 10,000 rpm and 4 °C in an SS-34 rotor (12,000×*g*). Decant the supernatant; centrifuge briefly at 4,000 rpm (2,000×*g*) and aspirate the remaining supernatant. Be sure to use barrier-tips when handling phage to avoid pipetman contamination.
7. Resuspend the phage pellet in 0.5 ml of PBS and transfer to a 1.5-ml microcentrifuge tube.
8. Centrifuge for 5 min at 13,000 rpm (15,800×*g*) in a microcentrifuge, and transfer the supernatant to a fresh 1.5-ml microcentrifuge tube.
9. Add 7.0 µl of buffer MP (Qiagen) and mix. Incubate at room temperature for at least 2 min.
10. Apply the sample to a QIAprep spin column (Qiagen) in a 2-ml microcentrifuge tube. Centrifuge for 30 s at 8,000 rpm (6,000×*g*) in a microcentrifuge. Discard the flow-through. The phage particles remain bound to the column matrix.
11. Add 0.7 ml of buffer MLB (Qiagen) to the column. Centrifuge for 30 s at 8,000 rpm (6,000×*g*) and discard the flow-through.
12. Add 0.7 ml buffer MLB and incubate at room temperature for at least 1 min.
13. Centrifuge at 8,000 rpm (6,000×*g*) for 30 s. Discard the flow-through. The DNA is separated from the protein coat and remains adsorbed to the matrix.
14. Add 0.7 ml buffer PE (Qiagen). Centrifuge at 8,000 rpm (6,000×*g*) for 30 s and discard the flow-through.
15. Repeat **step 14**. Residual proteins and salt are removed.
16. Centrifuge the column at 8,000 rpm (6,000×*g*) for 30 s to remove residual PE buffer.
17. Transfer the column to a fresh 1.5-ml microcentrifuge tube.

18. Add 100 μl buffer EB (Qiagen; 10 mM Tris-Cl, pH 8.5) to the center of the column membrane. Incubate at room temperature for 10 min.
19. Centrifuge for 30 s at 8,000 rpm (6,000 $\times g$). Save the eluant, which contains the purified dU-ssDNA.
20. Analyze the DNA by electrophoresis of 1.0 μl on a TAE/agarose gel. The DNA should appear as a predominant single band, but faint bands with lower electrophoretic mobility are often visible. These are likely caused by secondary structure in the dU-ssDNA.
21. Determine the DNA concentration by measuring absorbance at 260 nm ($A_{260} = 1.0$ for 33 ng/ μl of ssDNA). Typical DNA concentrations range from 200 to 500 ng/ μl .

3.2.2 *In Vitro*
 Synthesis of
 Heteroduplex CCC-dsDNA

A three-step procedure is used to incorporate the mutagenic oligonucleotides into heteroduplex CCC-dsDNA, using dU-ssDNA as a template. The protocol described here is an optimized, large-scale version of a published method [30]. The first step involves phosphorylation of the oligonucleotide that is subsequently annealed to the dU-ssDNA template. Annealed, phosphorylated oligonucleotides prime the template for enzymatic extension of the entire template sequence. Ligation results in the formation of ~20 μg of highly pure, low conductance, heteroduplex CCC-dsDNA that will require purification and desalting before electroporation.

Oligonucleotide
 Phosphorylation with T4
 Polynucleotide Kinase

1. Combine 0.6 μg mutagenic oligonucleotides designed to mutate a CDR with 2.0 μl 10 \times TM buffer, 2.0 μl 10 mM ATP, and 1.0 μl 100 mM DTT. Add water to a total volume of 20 μl in a 1.5-ml microcentrifuge tube. Each mutagenic oligonucleotide requires a separate phosphorylation reaction.
2. Add 20 U of T4 polynucleotide kinase to each tube and incubate for 1.0 h at 37 $^{\circ}\text{C}$. Use immediately for annealing.

Annealing of the
 Oligonucleotides
 to the Template

1. To 20 μg dU-ssDNA template, add 25 μl 10 \times TM buffer, 20 μl of each phosphorylated oligonucleotide, and water to a final volume of 250 μl . These DNA quantities provide an oligonucleotide:template molar ratio of 3:1, assuming that the oligonucleotide:template length ratio is 1:100.
2. Incubate at 90 $^{\circ}\text{C}$ for 3 min, 50 $^{\circ}\text{C}$ for 3 min, and 20 $^{\circ}\text{C}$ for 5 min.

Enzymatic Synthesis
 of CCC-dsDNA

1. To the annealed oligonucleotide/template mixture, add 10 μl 10 mM ATP, 10 μl 10 mM dNTP mix, 15 μl 100 mM DTT, 30 Weiss units T4 DNA ligase, and 30 U T7 DNA polymerase.
2. Incubate overnight at 20 $^{\circ}\text{C}$.

3. Purify and desalt the DNA using the Qiagen QIAquick DNA purification kit.
4. Add 1.0 ml of buffer QG (Qiagen) and mix.
5. Apply the sample over two QIAquick spin columns placed in 2-ml microcentrifuge tubes. Centrifuge at 13,000 rpm ($15,800 \times g$) for 1 min in a microcentrifuge. Discard the flow-through.
6. Add 750 μ l buffer PE (Qiagen) to each column, and centrifuge at 13,000 rpm ($15,800 \times g$) for 1 min. Discard the flow-through.
7. Centrifuge the column at 13,000 rpm ($15,800 \times g$) for 1 min to remove excess buffer PE.
8. Transfer the column to a fresh 1.5-ml microcentrifuge tube and add 35 μ l of ultrapure irrigation USP water to the center of the membrane. Incubate for 2 min at room temperature.
9. Centrifuge at 13,000 rpm ($15,800 \times g$) for 1 min to elute the DNA. Combine the eluants from the two columns. The DNA can be used immediately for *E. coli* electroporation or frozen for later use.
10. Electrophorese 1.0 μ l of the eluted reaction product alongside the ssDNA template (Fig. 3c). A successful reaction results in the complete conversion of ssDNA to dsDNA, which has a lower electrophoretic mobility. No ssDNA should remain and usually at least two product bands are visible. The product band with higher electrophoretic mobility represents the desired product: correctly extended and ligated CCC-dsDNA that transforms *E. coli* efficiently and provides a high mutation frequency ($\sim 80\%$). The product band with lower electrophoretic mobility is a strand-displaced product resulting from intrinsic, unwanted activity of T7 DNA polymerase [33] and provides a low mutation frequency ($\sim 20\%$) that transforms *E. coli* at least 30-fold less efficiently than CCC-dsDNA. If a significant proportion of the single-stranded template is converted to CCC-dsDNA, a highly diverse library with high mutation frequency will result. Sometimes a third band is visible, with an electrophoretic mobility between the other two product bands. This intermediate band is correctly extended but contains unligated dsDNA (knicked dsDNA) resulting from either insufficient T4 DNA ligase activity or from incomplete oligonucleotide phosphorylation.

3.2.3 Conversion of CCC-dsDNA into a Phage-Displayed Library

To complete library construction, the heteroduplex CCC-dsDNA is introduced into an *E. coli* host containing an F' episome to enable M13 bacteriophage infection and propagation. The limiting factor for phage-displayed library diversities are the methods for introducing DNA into *E. coli*, with the most efficient method being high-voltage electroporation. We have isolated an *E. coli* strain (SS320) that is ideal for both high-efficiency electroporation and phage production [32]. The following optimized protocols enable the production of

highly diverse libraries by the large-scale electroporation of CCC-dsDNA into specially prepared electrocompetent *E. coli* SS320 infected by M13KO7 helper phage.

Preparation of
Electrocompetent
E. coli SS320

The following protocol yields approximately 12 ml of highly concentrated, electrocompetent *E. coli* SS320 ($\sim 3 \times 10^{11}$ cfu/ml) infected by M13KO7 helper phage. Cells can be stored indefinitely at -80°C in 10 % glycerol. The use of *E. coli* infected by helper phage ensures that, once transformed with a phagemid, each cell will be able to produce phage particles without the need for further helper phage infection.

1. Inoculate 25 ml 2YT/tet medium with a single colony of *E. coli* SS320 from a fresh LB/tet plate. Incubate at 37°C with shaking at 200 rpm to mid-log phase ($\text{OD}_{600} = 0.8$).
2. Make tenfold serial dilutions of M13KO7 by diluting 20 μl into 180 μl of PBS (use a new pipette tip for each dilution).
3. Mix 500 μl aliquots of mid-log phase *E. coli* SS320 with 200 μl of each M13KO7 dilution and 4 ml 2YT top agar.
4. Pour the mixtures onto prewarmed LB/tet plates and grow overnight at 37°C .
5. Pick an average-sized single plaque and place in 1 ml of 2YT/kan/tet medium. Grow 8 h at 37°C with shaking at 200 rpm.
6. Transfer the culture to 250 ml 2YT/kan medium in a 2-L baffled flask. Grow overnight at 37°C with shaking at 200 rpm.
7. Inoculate six 2-L baffled flasks containing 900 ml superbroth/tet/kan medium with 5 ml of the overnight culture. Incubate at 37°C with shaking at 200 rpm to mid-log phase ($\text{OD}_{600} = 0.8$).
8. Chill three of the flasks on ice for 5 min with occasional swirling. The following steps should be done in a cold room, on ice, with prechilled solutions and equipment.
9. Centrifuge at 5,500 rpm ($5,000 \times g$) and 4°C for 10 min in a Sorvall GS-3 rotor.
10. Decant the supernatant and add culture from the remaining flasks (these should be chilled while the first set is centrifuging) to the same tubes.
11. Repeat the centrifugation and decant the supernatant.
12. Fill the tubes with 1.0 mM HEPES, pH 7.4, and add sterile magnetic stir bars to facilitate pellet resuspension. Swirl to dislodge the pellet from the tube wall and stir at a moderate rate to resuspend the pellet completely.
13. Centrifuge at 5,500 rpm ($5,000 \times g$) and 4°C for 10 min in a Sorvall GS-3 rotor. Decant the supernatant, being careful to retain the stir bar. To avoid disturbing the pellet, maintain the position of the centrifuge tube when removing from the rotor.

14. Repeat **steps 12 and 13**.
15. Resuspend each pellet in 150 ml of 10 % ultrapure glycerol. Use stirbars and do not combine the pellets.
16. Centrifuge at 5,500 rpm ($5,000\times g$) and 4 °C for 15 min in a Sorvall GS-3 rotor. Decant the supernatant and remove the stir bar. Remove remaining traces of supernatant with a pipette.
17. Add 3.0 ml 10 % ultrapure glycerol to one tube and resuspend the pellet by pipetting. Transfer the suspension to the next tube and repeat until all of the pellets are resuspended.
18. Transfer 350 μ l aliquots into 1.5-ml microcentrifuge tubes.
19. Flash freeze with liquid nitrogen and store at -80 °C.

E. coli Electroporation
and Phage Propagation

1. Chill the purified, desalted CCC-dsDNA (20 μ g in a maximum volume of 100 μ l) and a 0.2-cm gap electroporation cuvette on ice.
2. Thaw a 350 μ l aliquot of electrocompetent *E. coli* SS320 on ice. Add the cells to the DNA and mix by pipetting several times (avoid introducing bubbles).
3. Transfer the mixture to the cuvette and electroporate. For electroporation, follow the manufacturer's instructions, preferably using a BTX ECM-600 electroporation system with the following settings: 2.5 kV field strength, 125 Ω resistance, and 50 μ F capacitance.
4. Immediately rescue the electroporated cells by adding 1 ml SOC medium and transferring to 10 ml SOC medium in a 250-ml baffled flask. Rinse the cuvette twice with 1 ml SOC medium. Add SOC medium to a final volume of 25 ml.
5. Incubate for 30 min at 37 °C with shaking at 200 rpm.
6. To determine the library diversity, plate serial dilutions on LB/carb plates to select for the phagemid.
7. Transfer the culture to a 2-L baffled flask containing 500 ml 2YT medium, supplemented with antibiotics for phagemid and M13KO7 helper phage selection (e.g., 2YT/carb/kan medium).
8. Incubate overnight at 37 °C with shaking at 200 rpm.
9. Centrifuge the culture for 10 min at 10,000 rpm and 4 °C in a Sorvall GSA rotor ($16,000\times g$).
10. Transfer the supernatant to a fresh tube and add 1/5 final volume of PEG/NaCl solution to precipitate the phage. Incubate 5 min at room temperature.
11. Centrifuge for 10 min at 10,000 rpm and 4 °C in a GSA rotor ($16,000\times g$). Decant the supernatant. Spin briefly and remove the remaining supernatant with a pipette.

12. Resuspend the phage pellet in 20 ml of PBST buffer.
13. Pellet insoluble matter by centrifuging for 5 min at 15,000 rpm and 4 °C in an SS-34 rotor (27,000 × g). Transfer the supernatant to a clean tube.
14. Estimate the phage concentration spectrophotometrically ($OD_{268} = 1.0$ for a solution of 5×10^{12} phage/ml).
15. The library can be used immediately for selection experiments. Alternatively, the library can be frozen and stored at -80 °C, following the addition of glycerol to a final concentration of 10 %.

3.3 Selections with Synthetic Antibody Phage Libraries to Avoid Immuno-Dominance

Frequently synthetic and natural antibody libraries are prone to biased immuno-dominant responses, where the antibodies raised against an antigen show preference for a single epitope. To explore the signaling properties produced by targeting a range of epitopes, immuno-dominant bias of the library must be avoided. Epitope overlap between Fabs is often difficult to determine by Fab sequence alone and can require exhaustive biochemical analysis of hundreds or even thousands of clones to identify unique epitopes. To alleviate the need for extensive screening of reagents post-selection, we have developed a number of methods to address these issues during selections with synthetic libraries. There are many ways to target novel epitopes. Here we describe two methods to select for divergent epitopes based on using known immuno-dominant Fabs/IgGs or domain bins of an example hypothetical protein. Both these selection strategies will produce enriched phage pools to unique epitopes with high confidence. Phage within these populations can then be individually validated by ELISA and sequenced as described elsewhere [26].

3.3.1 Epitope Exclusion Selections

In this protocol we use a predetermined immuno-dominant Fab/IgG to block the dominant epitope, allowing for Fabs that recognize alternative epitopes to enrich in the phage population. As the Fab is now associated with the antigen, it is important to negatively select the phage library with the Fab alone before positive selection on the complex (Fig. 4b).

1. Coat a column of 8 wells (e.g. A3–H3) of a Maxi-Sorp 96-well plate with 25 µl of each antigen (2 µg/ml). Coat at least one column of eight wells with a negative selecting protein such as Fc, GST, or any stable protein unrelated to your antigen. Coat another eight wells with the immuno-dominant Fab alone. If the antigen of choice is fusion protein for stability or purification, use the fusion tag alone for negative selection. Incubate overnight at 4 °C or at 21 °C for 1 h.
2. Block the plate with 100 µl PBST, 0.5 % BSA for 30 min while gently mixing on oscillating plate mixer at 21 °C.

3. Aspirate blocking buffer and wash plate four times with 100 μ l PBST.
4. To antigen-coated wells, add 25 μ l of immuno-dominant Fab/IgG in PBST at a concentration ≥ 20 times than the measured K_D .
5. Save 10 μ l of naïve library or phage pool for analysis. Place in well A1 of a round bottom 96-well plate.
6. Negatively select the naïve library by adding 25 μ l phage library to the negatively selecting column. Incubate at 21 °C with gentle oscillation for 1 h.
7. Transfer 25 μ l of negatively selected naïve library to Fab-coated wells using an 8-channel pipette. Incubate at 21 °C for 30 min.
8. Transfer 25 μ l of Fab cleared, negatively selected library to antigen-coated wells in the presence of the immuno-dominant Fab/IgG using an 8-channel pipette. Incubate at 21 °C for 30 min.
9. Wash wells eight times with 100 μ l PBST using a 96-well plate washer.
10. Elute phage from each positively selecting fragment column with 100 μ l 0.1 M HCl for 10 min with gentle agitation.
11. Remove eluted phage from each positively selecting column well and pool. Neutralize 800 μ l of pooled eluted phage with 100 μ l 1 M Tris base (pH ~ 11).
12. Collect 10 μ l of eluted phage pool and transfer to a round bottom 96-well plate for analysis (*see step 20*).
13. Infect 5 ml OmniMAX cells grown in 2YT/tet ($OD_{600} = 0.8$) with neutralized phage. Incubate at 37 °C for 1 h while shaking at 200 rpm.
14. Add 5 μ l carbenicillin (50 mg/ml) and coinfect with 5 μ l M13KO7 helper phage ($>10^{10}$ pfu/ml).
15. Incubate for 1 h at 37 °C while shaking at 200 rpm.
16. Inoculate 25 ml 2YT/carb/tet/KO7 with 5 ml coinfecting OmniMAX culture. Let phage amplify for 12 h and pellet cells by centrifugation ($16,000 \times g$).
17. Transfer the supernatant to a fresh tube and add 1/5 final volume of PEG/NaCl solution to precipitate the phage. Incubate 20 min at room temperature. Gently invert tube occasionally.
18. Centrifuge for 10 min at 10,000 rpm and 4 °C in a GSA rotor ($16,000 \times g$). Decant the supernatant. Spin briefly (~2 min) and remove the remaining supernatant with a pipette.
19. Resuspend the phage pellet in 0.5 ml PBST buffer. Pellet the insoluble matter by centrifuging for 5 min at 15,000 rpm and 4 °C in a micro-centrifuge ($21,100 \times g$). Transfer the superna-

tant to a clean tube. This is now a pure amplified phage pool viral stock, which can be used in further rounds of selections or stored at $-20\text{ }^{\circ}\text{C}$ with 25 % glycerol and 1 mM Mg_2SO_4 .

20. Fill rows B–H of a 96-well analysis plate with 90 μl PBS. Begin serial dilutions by diluting the 10 μl aliquots in row A with 90 μl PBS and mix by pipetting up and down ten times. Transfer 10 μl of diluted phage from row A to B and mix again as described above. Transfer 10 μl of diluted phage to row C and mix as described above. Continue process until phage samples have been diluted 1:100,000,000 by factors of 10 (Rows A–H).
21. In a second 96-well plate, dispense 10 μl serially diluted phage from each well of the analysis plate to 90 μl OmniMAX culture grown in 2YT/tet medium to $\text{OD}_{600}=0.8$. Incubate at $37\text{ }^{\circ}\text{C}$ for 1 h.
22. Using an 8-channel pipette, spot 10 μl of each serial dilution on three agar plates containing the following selective media: 2YT/carb, 2YT/kan, or 2YT/tet. Grow at $37\text{ }^{\circ}\text{C}$ for 12 h. Use colony count per 10 μl drop to monitor phagemid enrichment rates compared to M13KO7 before and after selections.
23. Repeat selections (**steps 1–22**) three more times on enriched amplified phage pools using epitope exclusion as described above and illustrated in Fig. 4b.

3.3.2 Domain Exclusion Selections

In this protocol we use receptor fragments to strategically deplete sub-pools of the enriched phage population for specific domains of the antigen. This allows us to enrich phage specific for unique domain bins without having to express each individual domain independently. This strategy allows for the removal of epitope bias from a selection without any a priori knowledge of immuno-dominant epitopes, but it requires multiple forms of the antigen (Fig. 4c).

1. Using bioinformatic software (e.g., [interpro scan](#), [expasy.org](#)), delineate the number of domains in a receptor or antigen.
2. Clone, express, and purify the receptor as constructs with varying domain lengths (e.g., a five domain receptor could be broken down into five fragments: D1, D1–D2, D1–D3, D1–D4, and D1–D5). Use these receptor fragments as antigens in the selections described below.
3. Coat a column (e.g., A1–H1) of eight wells (B1) of a Maxi-Sorp 96-well plate with 25 μl of each receptor fragment (2 $\mu\text{g}/\text{ml}$). Coat at least one column of eight wells with a negative selecting protein such as Fc, GST, or any stable protein unrelated to your antigen. If the antigen of choice is fusion protein for stability or purification, use the fusion tag alone for negative selection. Incubate overnight at $4\text{ }^{\circ}\text{C}$ or for 1 h at $21\text{ }^{\circ}\text{C}$.

4. Block the plate with 100 μ l PBST, 0.5 % BSA for 30 min while gently mixing on an oscillating plate mixer.
5. Aspirate blocking buffer and wash plate four times with 100 μ l PBST.
6. Add 25 μ l PBST to each well.
7. Save 10 μ l of naïve library for analysis. Place in well A1 of a round bottom 96-well plate.
8. Aspirate the PBST from the negatively selecting column. Negatively select the naïve library by adding 25 μ l phage library to the negatively selecting column. Incubate at 21 °C while gently oscillating for 1 h.
9. Aspirate the PBST from a positive selecting column coated with the shortest fragment D1. Tilt the plate to pool phage solution to one side of the well. Transfer 25 μ l of negatively selected naïve library to the positively selecting column of wells using an 8-channel pipette. Incubate at 21 °C for 30 min.
10. Tilt the plate to pool phage solution to one side of the well. Transfer 25 μ l of library from the first positively selecting column to the second positively selecting column containing a longer fragment D1–D2 using an 8-channel pipette. Coat the first positively selecting column with 10 μ l of PBST. Incubate at 21 °C for 30 min.
11. Repeat **step 10** until the phage pool has been positively selected to all fragments of the receptor D1, D1–D2, D1–D3, D1–D4, and D1–D5. Since each positive selection acts as a negative selection for subsequent receptor fragments, it is critical that selections be carried out in a systematic order to avoid depleting Fab specificities that you wish to positively select.
12. Wash wells eight times with 100 μ l PBST using a 96-well plate washer.
13. Elute phage from each positively selecting fragment column with 100 μ l 0.1 M HCl for 10 min with gentle agitation.
14. Remove eluted phage from each positively selecting well and pool according to the antigen fragment (e.g., D1, D1–D2, D1–D3, D1–D4, D1–D5). Neutralize 800 μ l of pooled eluted phage with 100 μ l 1 M Tris base (pH ~11).
15. Collect 10 μ l eluted phage and transfer to wells A2–A12 of the round bottom 96-well analysis plate (*see step 23*).
16. Infect 5 ml *E. coli* OmniMAX cells grown in 2YT/tet medium (OD_{600} = 0.8) with 450 μ l of neutralized phage. Incubate at 37 °C for 1 h.
17. Add 5 μ l carbenicillin (50 mg/ml) and 5 μ l M13KO7 ($>10^{10}$ pfu/ml) helper phage to the *E. coli* OmniMAX culture.
18. Incubate for 1 h at 37 °C while shaking at 200 rpm.

19. Inoculate 25 ml of 2YT/carb/tet/KO7 medium with 5 ml coinfecting *E. coli* OmniMAX culture. Let phage amplify for 12 h.
20. Transfer the supernatant to a fresh tube and add 1/5 final volume of PEG/NaCl solution to precipitate the phage. Incubate 5 min at room temperature. Mix by gently inverting the tube occasionally.
21. Centrifuge for 10 min at 10,000 rpm and 4 °C in a GSA rotor (16,000×*g*). Decant the supernatant. Spin briefly (~2 min) and remove the remaining supernatant with a pipette.
22. Resuspend the phage pellet in 0.5 ml of PBT buffer. Pellet the insoluble matter by centrifuging for 5 min at 15,000 rpm and 4 °C in a micro-centrifuge (21,100×*g*). Transfer the supernatant to a clean tube. This is your phage pool viral stock, which can be used in further rounds of selections or stored at -20 °C with 25 % glycerol and 1 mM Mg₂SO₄.
23. Fill rows B–H of a 96-well analysis plate with 90 µl PBS. Begin serial dilutions by diluting the 10 µl aliquots in row A with 90 µl PBS and mix by pipetting up and down ten times. Transfer 10 µl of diluted phage from row A to B and mix again as described above. Transfer 10 µl of diluted phage to row C and mix as described above. Continue process until phage samples have been diluted 1:100,000,000 by factors of 10 (Rows A–H).
24. In a second 96-well plate, dispense 10 µl of serially diluted phage to 90 µl of *E. coli* OmniMAX culture grown in 2YT/tet to OD₆₀₀=0.8. Incubate at 37 °C for 1 h.
25. Using an 8-channel pipette, spot 10 µl of each serial dilution on three agar plates containing the following selective media: 2YT/carb, 2YT/kan, or 2YT/tet. Grow at 37 °C for 12 h. Use colonies to calculate phagemid enrichment rates compared to M13KO7 before and after selections.
26. Repeat selections (steps 3–26) three to four times on phage pools using domain exclusion as illustrated in Fig. 4c. Use negative selection on each receptor fragment to eliminate domain-specific paratopes from phage sub-pools while positively selecting for each domain independently as described above and illustrated in Fig. 4c.

References

1. Clamp M et al (2007) Distinguishing protein-coding and noncoding genes in the human genome. *Proc Natl Acad Sci USA* 104(49):19428–19433
2. Zhang C (2012) Hybridoma technology for the generation of monoclonal antibodies. *Methods Mol Biol* 901:117–135
3. Zhou H et al (2009) Generation of monoclonal antibodies against highly conserved antigens. *PLoS One* 4(6):e6087
4. Sims AH et al (2012) Defining the molecular response to trastuzumab, pertuzumab and combination therapy in ovarian cancer. *Br J Cancer* 106(11):1779–1789

5. Scheerlinck JP et al (1993) Redistribution of a murine humoral immune response following removal of an immunodominant B cell epitope from a recombinant fusion protein. *Mol Immunol* 30(8):733–739
6. Saldanha JW (2009) Humanization of recombinant antibodies. In: Little M (ed) *Recombinant antibodies for immunotherapy*. Cambridge Books Online, Cambridge, pp 3–19
7. Bradbury AR, Marks JD (2004) Antibodies from phage antibody libraries. *J Immunol Methods* 290(1–2):29–49
8. Hoogenboom HR (2005) Selecting and screening recombinant antibody libraries. *Nat Biotechnol* 23(9):1105–1116
9. Bradbury AR et al (2011) Beyond natural antibodies: the power of in vitro display technologies. *Nat Biotechnol* 29(3):245–254
10. Jespers LS et al (1994) Guiding the selection of human antibodies from phage display repertoires to a single epitope of an antigen. *Biotechnology (N Y)* 12(9):899–903
11. Bond CJ et al (2005) A structure-based database of antibody variable domain diversity. *J Mol Biol* 348(3):699–709
12. Fellouse FA et al (2007) High-throughput generation of synthetic antibodies from highly functional minimalist phage-displayed libraries. *J Mol Biol* 373(4):924–940
13. Uysal S et al (2009) Crystal structure of full-length KcsA in its closed conformation. *Proc Natl Acad Sci USA* 106(16):6644–6649
14. Ye JD et al (2008) Synthetic antibodies for specific recognition and crystallization of structured RNA. *Proc Natl Acad Sci USA* 105(1):82–87
15. Newton K et al (2008) Ubiquitin chain editing revealed by polyubiquitin linkage-specific antibodies. *Cell* 134(4):668–678
16. Gao J, Sidhu SS, Wells JA (2009) Two-state selection of conformation-specific antibodies. *Proc Natl Acad Sci USA* 106(9):3071–3076
17. Fellouse FA, Wiesmann C, Sidhu SS (2004) Synthetic antibodies from a four-amino-acid code: a dominant role for tyrosine in antigen recognition. *Proc Natl Acad Sci USA* 101(34):12467–12472
18. Birtalan S, Fisher RD, Sidhu SS (2010) The functional capacity of the natural amino acids for molecular recognition. *Mol Biosyst* 6(7):1186–1194
19. Fisher RD et al (2010) Structure of the complex between HER2 and an antibody paratope formed by side chains from tryptophan and serine. *J Mol Biol* 402(1):217–229
20. Birtalan S et al (2008) The intrinsic contributions of tyrosine, serine, glycine and arginine to the affinity and specificity of antibodies. *J Mol Biol* 377(5):1518–1528
21. Fellouse FA et al (2005) Molecular recognition by a binary code. *J Mol Biol* 348(5):1153–1162
22. Sidhu SS, Fellouse FA (2006) Synthetic therapeutic antibodies. *Nat Chem Biol* 2(12):682–688
23. Tonikian R et al (2007) Identifying specificity profiles for peptide recognition modules from phage-displayed peptide libraries. *Nat Protoc* 2(6):1368–1386
24. Nelson B, Sidhu SS (2012) Synthetic antibody libraries. *Methods Mol Biol* 899:27–41
25. Miersch S, Sidhu SS (2012) Synthetic antibodies: concepts, potential and practical considerations. *Methods* 57(4):486–498
26. Rajan S, Sidhu SS (2012) Simplified synthetic antibody libraries. *Methods Enzymol* 502:3–23
27. Lee CV et al (2004) High-affinity human antibodies from phage-displayed synthetic Fab libraries with a single framework scaffold. *J Mol Biol* 340(5):1073–1093
28. Sidhu SS et al (2004) Phage-displayed antibody libraries of synthetic heavy chain complementarity determining regions. *J Mol Biol* 338(2):299–310
29. Sidhu SS et al (2000) Phage display for selection of novel binding peptides. *Methods Enzymol* 328:333–363
30. Kunkel TA, Roberts JD, Zakour RA (1987) Rapid and efficient site-specific mutagenesis without phenotypic selection. *Methods Enzymol* 154:367–382
31. Sidhu SS, Weiss GA, Wells JA (2000) High copy display of large proteins on phage for functional selections. *J Mol Biol* 296(2):487–495
32. Sidhu SS (2000) Phage display in pharmaceutical biotechnology. *Curr Opin Biotechnol* 11(6):610–616
33. Lechner RL, Engler MJ, Richardson CC (1983) Characterization of strand displacement synthesis catalyzed by bacteriophage T7 DNA polymerase. *J Biol Chem* 258(18):11174–11184

Chapter 10

Production of Stabilized scFv Antibody Fragments in the *E. coli* Bacterial Cytoplasm

Lilach Vaks and Itai Benhar

Abstract

Monoclonal antibodies (mAbs) are currently the fastest growing class of therapeutic proteins. Parallel to full-length IgG format the development of recombinant technologies provided the production of smaller recombinant antibody variants. The single-chain variable fragment (scFv) antibody is a minimal form of functional antibody comprised of the variable domains of immunoglobulin light and heavy chains connected by a flexible linker. In most cases, scFvs are expressed in the bacterium *E. coli*. The production of soluble scFvs under the reducing conditions of the *E. coli* bacterial cytoplasm is inefficient because of the inability of the disulfide bonds to form. Hence, scFvs are either secreted to the periplasm as soluble proteins or expressed in the cytoplasm as insoluble inclusion bodies and recovered by refolding. The cytoplasmic expression of scFvs as a C-terminal fusion to maltose-binding protein (MBP) provided the high-level production of stable, soluble, and functional fusion protein. The below protocol provides the detailed description of MBP-scFv production in *E. coli* utilizing two expression systems: pMalc-TNN and pMalc-NHNN. Although the MBP tag does not disrupt the most of antibody activities, the MBP-TNN-scFv product can be cleaved by TEV protease in order to obtain untagged scFv.

Key words Single-chain variable fragment (scFv), Maltose-binding protein (MBP), Tobacco etch virus (TEV)

1 Introduction

Monoclonal antibodies (mAbs) are currently the fastest growing class of therapeutic proteins and represent one third of the total number of proteins used for therapy of various diseases in developed countries [1]. The production of fully human mAbs using transgenic mice [2, 3], human hybridomas [4], or *Escherichia coli* (*E. coli*) bacteria [5] permits an almost unlimited antibody supply for clinical and research applications. The development of recombinant technologies provided the production of recombinant antibody variants based on different forms of variable domains [6]. The commonly used single-chain variable fragment (scFv) antibodies are a minimal form of functional antibodies comprising of

only the variable domains of the immunoglobulin heavy and light chain connected by a short flexible peptide linker [7]. In contrast to the bivalent stable 150 kDa IgG molecule, the smaller 25 kDa scFv fragment is monovalent and upon intravenous injection possesses a short serum half-life of only a few hours [8]. Furthermore, due to its small size, the scFv is considered to have better tumor penetration compared to IgG due to its diffusion properties, making it more suitable tool in anticancer therapy and imaging [9, 10].

A recombinant scFv can be produced in a variety of different systems ranging from bacteria to mammalian cells. However, the reducing environment of the bacterial cytoplasm inhibits the formation of the intradomain disulfide bonds within the scFv. The common solution for that is secretion of the scFv to the bacterial periplasm where the oxidizing conditions facilitate the formation of the disulfide bonds [11]. As an alternative that allows exceptionally high level of expression, we suggested the expression of the recombinant antibodies as a C-terminal fusion with the *E. coli* maltose-binding protein (MBP) that stabilized the scFv and provided the efficient functional expression in the cell cytoplasm as a soluble, active form [12]. For most cases, the presence of MBP does not have any negative effect on the majority of antibody properties. Moreover, MBP-scFv fusion protein demonstrated higher stability and functionality in vitro than unfused scFv produced in *E. coli* cytoplasm [12]. In addition, MBP can be used as a tag for affinity purification of the recombinant antibody.

However, the immunogenicity of the bacterial MBP does not allow applying MBP-fusion antibodies in animal and human research in vivo. Therefore, after MBP served its purpose of allowing efficient expression and purification it should be removed. To facilitate that we introduced the tobacco etch virus (TEV) protease cleavage site between the MBP and the scFv. TEV protease is a 27 kDa catalytic domain of the Nuclear Inclusion protein (NIa) that recognizes and cleaves specific amino acid consensus sequence (ENLYFQS) leaving only an N-terminal Serine as an N-terminal extension of the scFv [13]. Thus, the released scFv fragment does not contain an immunogenic tag making it suitable for in vivo application.

In this chapter we describe two different approaches for production of single-chain antibodies in *E. coli* bacteria that include:

1. Expression using plasmid pMALc-TNN-scFv that encodes the MBP-scFv fusion construct with a TEV protease cleavage site between the fused proteins (Fig. 1a). This provides the opportunity to express the scFv as a soluble protein in the cytoplasmic fraction, purify it on an amylose resin column, cleave the antibody from its tag and obtain the purified scFv.
2. Expression using plasmid pMALc-NHNN-scFv that encodes a 6His-tag-MBP-scFv fusion construct that enables the purification of the protein on either Ni-NTA or amylose purification

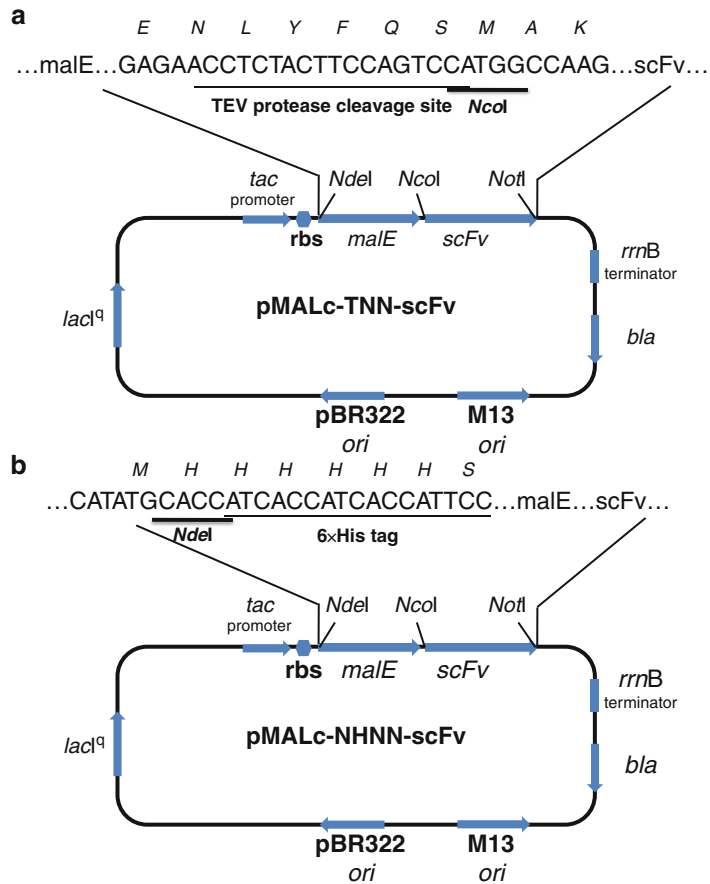

Fig. 1 Maps of pMALc plasmids. Plasmids pMalc-TNN (a) and pMalc-NHNN (b) are ampicillin-resistance carrying *colE1* replicon-based medium copy number plasmids. The plasmids were designed for expression of scFvs, fused to the C-terminus of MBP in the *E. coli* cytoplasm, in a soluble and active form under control of an IPTG-inducible *tac* promoter. pMalc allows the cloning of scFv of interest as *NcoI-NotI* fragments to create an open reading frame which codes for a fusion between the cloned scFv and the C-terminus of MBP. (a) pMalc-TNN plasmid contains the TEV protease recognition site between MBP and scFv that provides the opportunity for controlled release of the single-chain antibody protein fragment from its MBP tag. (b) pMalc-NHNN plasmid encodes 6×His tag at N-terminus of MBP-scFv construct. The resulted fusion protein can be purified using either MBP or 6×His tag, or sequential purification steps using both tags. *MalE* maltose-binding protein (MBP), *Bla* beta-lactamase

columns (*see Note 1*). Moreover, a sequential purification by both columns can be used (Figs. 1b and 2). Although, there is no TEV protease cleavage site to remove the tag in this construct, the presence of maltose binding protein for most cases does not influence the antibody's binding properties and is very convenient for rapid screening of a large number of scFvs (*see Notes 2 and 3*).

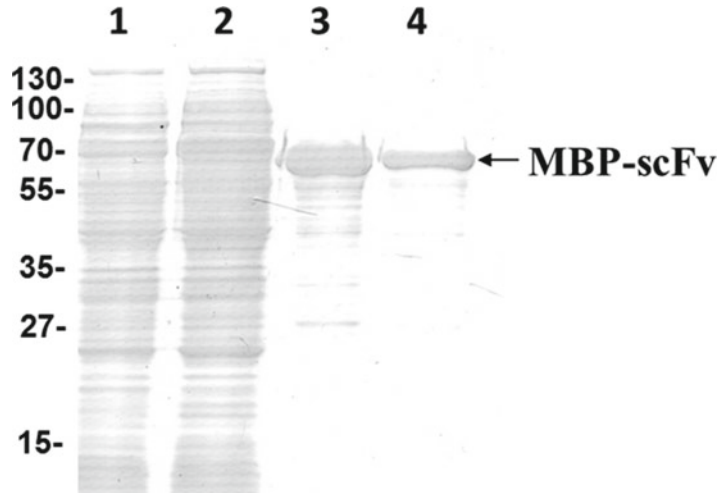

Fig. 2 SDS-PAGE analysis of 6×His-tag-MBP-scFv expression and purification. pMALc-NHNN-scFv vector was used for transformation to *E. coli* Rosetta BL-21 bacteria. The culture was induced for protein expression using IPTG followed by protein purification from soluble cytoplasmic fraction. Protein samples were separated on an SDS 12 % polyacrylamide gel and visualized using Coomassie blue staining. *Lane 1*: uninduced soluble fraction; *lane 2*: induced soluble fraction of 6×His-tag-MBP-scFv; *lane 3*: amylose resin purified 6×His-tag-MBP-scFv; *lane 4*: Ni-NTA purified 6×His-tag-MBP-scFv (previously purified on amylose resin)

2 Materials (See Note 4)

2.1 Construction of pMALc-scFv of Interest

1. Vectors: pMALc-TNN or pMALc-NHNN (*see Note 5*) previously digested with *NcoI* and *NotI* restriction enzymes (*see Note 6*).
2. Single-chain fragment of antibody of interest (*see Note 7*).
3. Primers: *NcoI*-scFv-For (5'-tatataCCATGGcc-scFv sequence-3') and *NotI*-scFv-Rev (5'-tatataGCGGCCGCTTA-scFv sequence-3') (*see Note 8*) for amplification of the scFv. Primer malc6-seq (5'-gacgcgagactaattcgagc-3') can be used for sequencing of the insert cloned in either plasmid.
4. PCR Master Mix 2×Reddy Mix™ (Abgene (<http://www.abgene.com>)) for amplification of scFv fragment.
5. PCR cleanup kit (Geneaid (<http://www.geneaid.com>)).
6. Restriction enzymes: *NcoI* and *NotI* (New England Biolabs (<http://www.neb.com>)).
7. T4 DNA ligase (New England Biolabs (<http://www.neb.com>)).
8. Bacteria strains: *E. coli* DH5α strain (GibcoBRL, Life Technologies (<http://www.lifetechnologies.com>)) is used for cloning.

9. Ampicillin antibiotic (*see* Subheading 2.7).
10. Growth media: Yeast extract-tryptone $\times 2$ (2 \times YT) (*see* Subheading 2.8).

2.2 Expression Using Plasmid pMALc-NHNN/TNN-scFv

1. Vectors: pMALc-TNN-scFv or pMALc-NHNN-scFv (*see* Note 5).
2. Bacteria strain: *E. coli* Rosetta BL-21 (Novagen, now EMD4Biosciences:<http://www.emdmillipore.com/life-science-research>).
3. Antibiotics: ampicillin, chloramphenicol (*see* Subheading 2.7).
4. Luria-Bertani (LB) growth media (*see* Subheading 2.8).
5. Isopropyl β -D-1-thiogalactopyranoside (IPTG): use 0.5 mM for scFv overexpression (*see* Subheading 2.7).

2.3 Purification of pMALc-NHNN-scFv on a Nickel-NTA Column

1. Binding buffer: 50 mM NaH₂PO₄, 0.3 M NaCl, 10 mM imidazole, adjust to pH 8.0. Filter or sterilize by autoclaving. (All the reagents were purchased in Merck & Co., Inc. (<http://www.merck.com>)).
2. Sonication device: ultrasonic liquid processor. Optionally cell disruption by French press apparatus can be used.
3. Ni-NTA agarose beads (Invitrogen, http://tools.invitrogen.com/content/sfs/manuals/ninta_system_man.pdf).
4. 10 ml gravity-flow polypropylene columns (Pierce, now Thermo Scientific (<http://www.piercenet.com>)).
5. Imidazole (0.5 M in PBS) for elution of His-tagged protein from the column (Merck & Co., Inc. (<http://www.merck.com>)).
6. For dialysis: SnakeSkin-Pleated Dialysis tubing (10 kDa cutoff) supplied by Pierce (now Thermo Scientific (<http://www.piercenet.com>)).

2.4 Purification on an Amylose Resin Column

1. Phosphate buffered saline (PBS) (*see* Subheading 2.7) + 0.5 % Triton X-100 detergent (Sigma, <http://www.sigmaaldrich.com>).
2. Sonication device: ultrasonic liquid processor.
3. Amylose resin (New England Biolabs (<http://www.neb.com>)).
4. 10 ml gravity-flow polypropylene columns (Pierce, now Thermo Scientific (<http://www.piercenet.com>)).
5. For elution: 20 mM maltose in PBS. Maltose was purchased in Sigma (<http://www.sigmaaldrich.com>). For PBS preparation *see* Subheading 2.8.

2.5 Expression and Purification of TEV Protease

The TEV protease is commercially available from several vendors (such as Invitrogen (<http://www.invitrogen.com>)). We use plasmid pRK508-TEV [14] for the expression of MBP-TEV protease fusion that can be later purified on amylose column.

1. Vector: pRK508-TEV (*see Note 9*).
2. Bacterial strain: *E. coli* Rosetta BL-21 (Novagen, now EMD4Biosciences: <http://www.emdmillipore.com/life-science-research>).
3. Antibiotics: ampicillin, chloramphenicol (*see Subheading 2.7*).
4. Luria-Bertani (LB) growth media (*see Subheading 2.8*).
5. Isopropyl β -D-1-thiogalactopyranoside (IPTG): use 0.5 mM for overexpression (*see Subheading 2.7*).
6. Phosphate buffered saline (PBS) (*see Subheading 2.7*)+0.5 % Triton X-100 detergent (Sigma, <http://www.sigmaaldrich.com>).
7. Sonication device: ultrasonic liquid processor.
8. Amylose resin (New England Biolabs (<http://www.neb.com>)).
9. 10 ml gravity-flow polypropylene columns (Pierce, now Thermo Scientific (<http://www.piercenet.com>)).
10. For elution: 20 mM maltose in PBS. Maltose was purchased in Sigma (<http://www.sigmaaldrich.com>). For PBS preparation *see Subheading 2.8*.

2.6 Cleavage with TEV Protease and Purification of scFv Fragment

1. TEV reaction buffer \times 20: 1 M Tris-HCl (pH 8.0), 10 mM EDTA (Merck & Co., Inc. (<http://www.merck.com>)).
2. 0.1 M DTT in sterile water (Sigma (<http://www.sigmaaldrich.com>)).
3. Amylose resin (New England Biolabs) (<http://www.neb.com>).
4. 10 ml gravity-flow polypropylene columns (Pierce, now Thermo Scientific (<http://www.piercenet.com>)).

2.7 General Buffers and Reagents

1. Phosphate buffered saline (PBS): 8 g NaCl, 0.2 g KCl, 1.44 g Na₂HPO₄, 0.24 g KH₂PO₄ per 1 L, pH 7.4. (The reagents were purchased in Merck & Co., Inc. (<http://www.merck.com>)).
2. Chloramphenicol (Sigma (<http://www.sigmaaldrich.com>)): 34 mg/ml in 100 % ethanol. Store at -20 °C.
3. Ampicillin (Roche Diagnostics (<http://www.roche.com>)): 100 mg/ml in water. Store at -20 °C.
4. Isopropyl β -D-1-thiogalactopyranoside (IPTG) (Bio-Lab LTD. (<http://www.biolab-chemicals.com>)): 1 M in sterile double-distilled (MilliQ) water (SDDW) stored in 1 ml aliquots at -20 °C.

2.8 Bacteria Growth Media

These may be purchased from any supplier of common bacterial growth medium components or preprepared media. In our lab we use products of Becton-Dickinson (<http://www.bd.com/>).

1. 2×YT: 16 g Bacto-Tryptone, 10 g Yeast extract, 5 g NaCl/L water.
2. LB: 10 g Bacto-Tryptone, 5 g Yeast extract, 10 g NaCl/L water.

To prepare solid media, Bacto-agar at the final concentration of 1.8 % was added to the solutions. Following the autoclaving, the media were supplemented with 0.4 % glucose and antibiotics. The final concentrations of the antibiotics used in this study were as follows: ampicillin: 100 µg/ml, chloramphenicol: 34 µg/ml.

3 Methods

The protocol described below provides the description of scFv production process. The expression of single-chain antibody fragment as MBP-fusions improves its stability and solubility and results in higher production yield of MBP-scFv in an *E. coli* expression system. Besides its “chaperon-like” activity, MBP serves for affinity purification of the scFv construct on amylose resin column. In addition, the pMALc-NHNN vector contains the N-terminal 6×His-tag fused to the MBP-scFv construct for possible purification by Ni-NTA column chromatography. The pMALc-TNN plasmid is used to express MBP-scFv containing TEV protease cleavage site separating the scFv from MBP-tag. Although commercial versions of TEV protease are available (Invitrogen (<http://www.invitrogen.com>)), we describe the expression of MBP-TEV construct in *E. coli* for digestion of the MBP-scFv fusion protein. The main advantage of using “home-made” MBP-TEV protein is the fact that un-tagged scFv will not be trapped by amylose resin, thus can be easily separated from other reaction component.

3.1 Construction of pMALc-scFv of Interest

The pMALc vectors can be used for expression of scFv originated from any organism if the codon usage in *E. coli* bacteria was taken under consideration (*see Note 10*). In spite of the differences between pMALc-TNN and pMALc-NHNN described above, the cloning procedure of single-chain antibody fragment for both vectors is identical.

1. The single-chain antibody of interest (designated as scFv) should be amplified by PCR using *NcoI*-scFv-For and *NotI*-scFv-Rev primers (*see Subheading 2.1*). The PCR reaction conditions are: 95 °C for 5 min; 30 cycles of: 94 °C for 30 s, 55 °C

for 1 min, 72 °C for 1 min; and a final extension of 72 °C for 5 min. The final reaction volume is 50 µl.

2. Purify the resulted PCR product using a PCR cleanup kit (*see Note 11*).
3. Digest the purified PCR fragment with *NotI* and *NcoI* restriction enzymes for 1–1.5 h at 37 °C followed by gel extraction or PCR cleanup.
4. Clone the digested scFv insert to previously *NcoI/NotI* digested pMALc vector by standard ligation procedure and transform it into *E. coli* DH5α competent cells.
5. The success of the cloning should be verified by sequencing using the malc6-seq primer.

3.2 Expression of pMALc-NHNN/TNN-scFv

The expression procedure for pMALc-NHNN-scFv and pMALc-TNN-scFv is identical.

1. Transform Rosetta BL-21 competent cells with pMALc-NHNN/TNN-scFv vector to and plate the transformed cells on a 2×YT-agar plate containing: 100 µg/ml ampicillin and 34 µg/ml chloramphenicol. Leave for 16 h at 37 °C until colonies of transformed bacteria are clearly visible.
2. Inoculate 500 ml of LB+100 µg/ml ampicillin in a 2 L Erlenmeyer flask with pooled colonies scraped off the plate.
3. Grow shaking (250 rpm) at 37 °C to an OD_{600 nm} (optical density) = 0.6–0.8 (about 3 h).
4. For induction add IPTG to the culture to 0.5 mM final concentration.
5. Continue culture growth for 4 h at 30 °C shaking (250 rpm).
6. Spin down the cells by centrifugation at 8,000 × *g* for 30 min. For centrifugation we use RC5C Sorvall centrifuge GSA rotor (Thermo Scientific (<http://www.piercenet.com>)).
7. It is possible to store the cell pellet at –20 °C for several weeks. Alternatively, you can immediately proceed to the cell lysis and protein purification steps.

3.3 Purification of 6×His-MBP-scFv on a Nickel-NTA Column

As was mentioned above, the pMALc-NHNN-scFv construct contains a 6×His-tag that enables the purification of the MBP-scFvs by Nickel-NTA chromatography. It is highly recommended to evaluate the protein concentration and efficiency of induction prior to purification step by SDS-PAGE.

1. Resuspend the cell pellet in cold 1/5 volume (of the induced culture) of binding buffer (*see Subheading 2.3*).
2. Lyse by sonication on ice.

3. Centrifuge at $18,500\times g$ for 30 min at 4 °C to remove the insoluble fraction of the cell lysate. For centrifugation we use 5810R centrifuge (Eppendorf (<http://www.eppendorf.com>)).
4. Transfer the soluble fraction to a clean 50 ml tube and keep it on ice.
5. Prepare the Ni-NTA agarose beads according to vendor's recommendations and wash them with binding buffer. Place them in a gravity column.
6. Load the cell extract and collect flow-through by gravity flow (*see Note 12*).
7. Wash the column with 50 ml of binding buffer.
8. Elute the MBP-scFv fusion protein with 0.5 M imidazole in PBS. Collect ten fraction (2 ml each) and pool protein containing fractions.
9. Analyze the purified MBP-scFv by SDS/PAGE (as shown in Fig. 2).
10. Perform two-step dialysis against PBS at 4 °C using at least 100 volumes of the combined eluate fractions for each dialysis.
11. Store the protein at a final concentration 1 mg/ml at 4 °C. For prolonged storage (longer than 1–2 weeks) store in small aliquots at –80 °C.

3.4 Purification of 6xHis-MBP-scFv and MBP-scFv on an Amylose Resin Column

Both vectors, pMALc-NHNN-scFv and pMALc-TNN-scFv, enable the production of MBP-fused proteins that can be later purified on amylose resin column chromatography. We recommend the evaluation of the protein concentration and efficiency of induction prior to purification step by SDS-PAGE.

1. Resuspend the cell pellet in cold 1/5 volume of PBS+0.1 % Triton X-100.
2. Sonicate on ice until complete lysis is reached.
3. Spin 30 min $18,500\times g$ at 4 °C to remove the insoluble fraction of the cell lysate. For centrifugation we use 5810R centrifuge (Eppendorf (<http://www.eppendorf.com>)).
4. Save the soluble fraction and keep it on ice.
5. Prepare the amylose resin column according to vendor's recommendations and wash the beads with PBS.
6. Load the cell extract on the column and collect flow-through by gravity flow (*see Note 12*).
7. Wash the column with 50 ml PBS.
8. Elute the protein with 20 mM maltose in PBS. Collect 2 ml fractions and pool protein containing fractions.
9. Analyze the purified MBP-scFv by SDS/PAGE (as shown in Fig. 2).

10. Keep the purified protein at a final concentration of 1 mg/ml at 4 °C. For prolonged storage (longer than 1–2 weeks) store in small aliquots at –80 °C. No dialysis step is required.

3.5 Expression and Purification of TEV Protease

The TEV protease is expressed as MBP-fusion and purified on amylose column similar to MBP-scFv purification described in Subheadings 3.2 and 3.4.

1. Transform Rosetta BL-21 competent cells with pRK508-TEV vector and plate the transformed cells on a 2×YT-agar plate containing 100 µg/ml ampicillin and 34 µg/ml chloramphenicol. Leave for 16 h at 37 °C until colonies are clearly visible.
2. Collect the bacteria colonies into 500 ml LB containing 100 µg/ml ampicillin.
3. Grow shaking (250 rpm) at 37 °C to an OD_{600 nm} = 0.6–0.8.
4. Induce the culture by adding IPTG to a final concentration of 1 mM.
5. Continue shaking overnight at 16 °C (250 rpm).
6. Harvest the cells by centrifugation at 8,000×g for 30 min. For centrifugation we use RC5C Sorvall centrifuge GSA rotor (Thermo Scientific (<http://www.piercenet.com>)).
7. It is possible to store the cells pellet at –20 °C for several weeks or immediately continue to purification steps.
8. Resuspend the cell pellet in cold 1/5 volume of PBS+0.1 % Triton X-100.
9. Perform sonication on ice until complete lysis is achieved.
10. Centrifuge at 18,500×g for 30 min at 4 °C to remove the insoluble fraction of the cell lysate. For centrifugation we use 5810R centrifuge (Eppendorf (<http://www.eppendorf.com>)).
11. Transfer the soluble fraction to a clean tube and keep on ice.
12. Prepare the amylose resin column and wash the beads with PBS.
13. Load the cell extract (*see Note 12*).
14. Wash the column with 50 ml PBS.
15. Elute the protein with 20 mM maltose in PBS. Collect ten fractions (2 ml each) and pool protein containing fractions.
16. Store the purified MBP-TEV protease at a final concentration of 1 mg/ml stored in small aliquots at –80 °C. No dialysis step is required.

3.6 Cutting the MBP-TNN-scFv with TEV Protease and Purification of the scFv Fragment

The purification of the untagged scFv is based on the fact that both the TEV protease and the uncleaved MBP-scFv fusion protein are fused to MBP and can be trapped by an amylose column. The cleaved scFv will not bind to the column and will accumulate in the flow through (unbound) fraction. Since amylose does not always

provide a highly purified fusion protein as a single purification step (Fig. 3), for a higher level of protein purity we recommend to perform sequential purification steps using size exclusion chromatography after Amylose resin purification (*see Note 13*).

1. Add the following to the microcentrifuge tube:
 - (a) 100 μg amylose purified MBP-scFv.
 - (b) 37.5 μl TEV reaction buffer $\times 20$.
 - (c) 10 μl MBP-TEV (stock concentration 1 mg/ml).
 - (d) 7.5 μl 0.1 M DTT.
 - (e) Sterile deionized water up to 750 μl .
2. Incubate at 16 $^{\circ}\text{C}$ overnight (*see Notes 14 and 15*).
3. Prepare the amylose resin column and wash the beads with PBS.
4. Load the protein mixture and collect the flow-through.
5. Determine the scFv concentration in the flow through fraction.

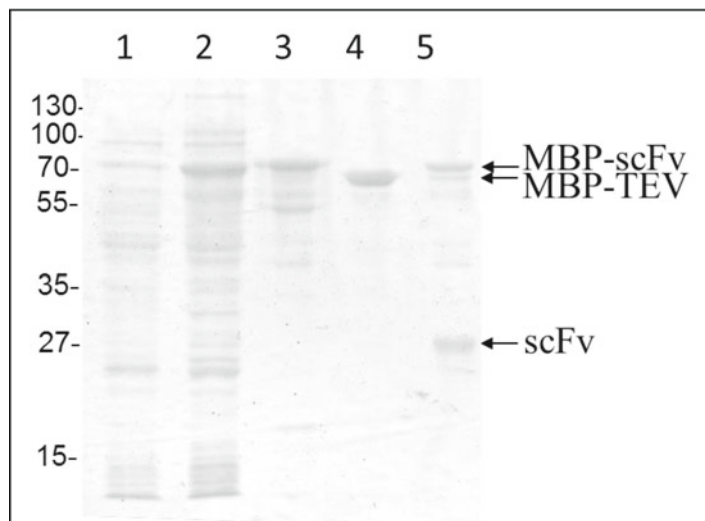

Fig. 3 SDS-PAGE analysis of scFv expression and purification using pMALc-TNN expression system. pMALc-TNN-scFv vector was used for transformation to *E. coli* Rosetta BL-21 bacteria. The culture was induced for protein expression using IPTG followed by protein purification from soluble cytoplasmic fraction. The amylose purified MBP-scFv fusion protein was cleaved with TEV protease that released the scFv from the MBP tag. TEV protease that was used in this work was produced in *E. coli* Rosetta BL-21 bacteria as MBP fusion and purified on amylose resin. The purification of untagged scFv was provided by loading on amylose resin column and collection of unbound fraction. Protein samples were separated on an SDS 12 % polyacrylamide gel and visualized using Coomassie blue staining. Lane 1: uninduced fraction; lane 2: induced MBP-TNN-scFv; lane 3: amylose purified MBP-TNN-scFv; lane 4: amylose purified MBP-TEV; lane 5: amylose (partially) purified untagged scFv (*see Note 13*)

6. Analyze the purified MBP-scFv by SDS/PAGE (as shown in Fig. 3).
7. Store the protein at 4 °C. For prolonged storage (longer than 1 week) store in small aliquots at -80 °C.

4 Notes

1. For efficient purification of MBP fused proteins on amylose resin, it is important to ensure a high levels of the induced proteins within the total soluble fraction (20–30 %). In cases of low induction levels, we recommend preparing the scFv gene by total gene synthesis with optimization for expression in *E. coli*.
2. The presence of fused MBP does not influence scFv protein characteristics. On the other hand, the high immunogenicity of MBP is problematic in terms of its application in animal or human studies for determination of antibody pharmacokinetics, distribution, or therapeutic efficacy.
3. In the protocol, we recommend using sequential chromatography on amylose and Ni-NTA columns. A single-step purification, while in many cases is sufficient for preliminary analysis, rarely provides highly purified proteins. When using pMALc-TNN-scFv that does not contain a built-in 6×His-tag, the user is advised to append one by PCR to the 3' end of the scFv-coding DNA. Alternatively, a 6×His-tag may be appended to the 5' end of the MBP coding sequence as presented in the example of the pMALc-NHNN-scFv plasmid.
4. In the list of Materials (Subheading 2) we provide the names of vendors from which we currently purchase reagents. We do not by any means endorse these particular vendors. We provide the URLs of the vendor sites which are now more commonly used than their physical addresses.
5. The vectors should be purified by miniprep kit. The pMALc plasmid concentration is commonly low: 50–150 ng/μl. Do not continue to a digestion step with plasmid concentration lower than 30 ng/μl.
6. *NotI* restriction enzyme better digests linear DNA. For a successful digestion, we recommend to incubate the uncut plasmid with *NcoI* for 1 h at 37 °C and afterwards to add *NotI* for an additional 1 h incubation. No DNA cleanup procedure between the enzymes is required.
7. For construction of scFv from full length IgG, see ref. 15.

8. For construction of *Nco*I-scFv-For primer use the 18 initial nucleotides of the antibody of interest (no ATG start codon is needed) following the sequence described in Subheading 2.1. For construction of *Not*I-scFv-Rev primer use the reverse complement C-terminal sequence of scFv follow the sequence described in Subheading 2.1 (no stop codon is needed).
9. Plasmid pRK508-TEV for the expression of the TEV protease was kindly provided by Dr. David Waugh, Macromolecular Crystallography Laboratory, National Cancer Institute at Frederick, MD, USA.
10. The low expression levels of the desired protein can be explained by deficiency of a particular aminoacyl tRNA in *E. coli* strain for a particular codon in antibody sequence. The problem can be solved by gene optimization technique or by using the special *E. coli* strains for protein expression.
11. Unless mentioned otherwise, standard protocols of the commercially obtained kits should be used during cloning and purification processes.
12. In the presented protocol we describe the protein purification using gravity-flow columns. For purification using FPLC pump using for example MBPTrap columns (GE Healthcare (<http://www.gehealthcare.com>)), loading at 1 ml/min is preferable.
13. We recommend carrying out size exclusion chromatography not just a polishing step after TEV protease-mediated removal of MBP but also on intact MBP-scFvs. This is important for two reasons: one is that amylose affinity chromatography does not always provide high purity of MBP fusion proteins (Fig. 3). The second reason; in some cases, MBP-based fusion proteins have been shown to form soluble oligomers (also called “soluble aggregates”) [16–18]. Although not common, this may occur with MBP-scFvs too (our unpublished observations). To make sure you obtain reliable functional data of your antibodies you should make sure you are working with soluble monomers with a MW of about 65–70 kDa. Size exclusion chromatography may be accrued out using for example a Superdex 200 column (GE Healthcare (<http://www.gehealthcare.com>)) according to the recommendations of the supplier.
14. Although TEV protease is maximally active at 34 °C, we recommend performing the prolonged incubation at 16 °C to ensure the stability of cleaved scFv.
15. To ensure the cleavage efficiency, analyze the protein mixture following the incubation with TEV protease by SDS-PAGE electrophoresis.

References

1. Hagemeyer CE, von Zur Muhlen C, von Elverfeldt D, Peter K (2009) Single-chain antibodies as diagnostic tools and therapeutic agents. *Thromb Haemost* 101:1012–1019
2. Green LL (1999) Antibody engineering via genetic engineering of the mouse: XenoMouse strains are a vehicle for the facile generation of therapeutic human monoclonal antibodies. *J Immunol Methods* 231:11–23
3. Tomizuka K, Shinohara T, Yoshida H, Uejima H, Ohguma A, Tanaka S, Sato K, Oshimura M, Ishida I (2000) Double trans-chromosomal mice: maintenance of two individual human chromosome fragments containing Ig heavy and kappa loci and expression of fully human antibodies. *Proc Natl Acad Sci USA* 97:722–727
4. Terness P, Welschof M, Moldenhauer G, Jung M, Moroder L, Kirchhoff F, Kipriyanov S, Little M, Opelz G (1997) Idiotypic vaccine for treatment of human B-cell lymphoma. Construction of IgG variable regions from single malignant B cells. *Hum Immunol* 56:17–27
5. Hakim R, Benhar I (2009) “Inclonals”: IgG and IgG-enzyme fusion proteins produced in an *E. coli* expression-refolding system. *MAbs* 1:281–287
6. Kipriyanov SM (2003) Generation of antibody molecules through antibody engineering. *Methods Mol Biol* 207:3–25
7. Bird RE, Hardman KD, Jacobson JW, Johnson S, Kaufman BM, Lee SM, Lee T, Pope SH, Riordan GS, Whitlow M (1988) Single-chain antigen-binding proteins. *Science* 242:423–426
8. Kim SJ, Park Y, Hong HJ (2005) Antibody engineering for the development of therapeutic antibodies. *Mol Cells* 20:17–29
9. Olafsen T, Sirk SJ, Betting DJ, Kenanova VE, Bauer KB, Ladno W, Raubitschek AA, Timmerman JM, Wu AM (2010) ImmunoPET imaging of B-cell lymphoma using 124I-anti-CD20 scFv dimers (diabodies). *Protein Eng Des Sel* 23:243–249
10. Yokota T, Milenic DE, Whitlow M, Schlom J (1992) Rapid tumor penetration of a single-chain Fv and comparison with other immunoglobulin forms. *Cancer Res* 52:3402–3408
11. Kipriyanov S (2002) High-level periplasmic expression and purification of scFvs. In: O’Brien PM, Aitken R (eds) *Antibody phage display*. Humana, New Jersey, pp 333–341
12. Bach H, Mazor Y, Shaky S, Shoham-Lev A, Berdichevsky Y, Gutnick DL, Benhar I (2001) *Escherichia coli* maltose-binding protein as a molecular chaperone for recombinant intracellular cytoplasmic single-chain antibodies. *J Mol Biol* 312:79–93
13. Kapust RB, Waugh DS (2000) Controlled intracellular processing of fusion proteins by TEV protease. *Protein Expr Purif* 19:312–318
14. Kapust RB, Waugh DS (1999) *Escherichia coli* maltose-binding protein is uncommonly effective at promoting the solubility of polypeptides to which it is fused. *Protein Sci* 8:1668–1674
15. Huston JS, Levinson D, Mudgett-Hunter M, Tai MS, Novotny J, Margolies MN, Ridge RJ, Bruccoleri RE, Haber E, Crea R et al (1988) Protein engineering of antibody binding sites: recovery of specific activity in an anti-digoxin single-chain Fv analogue produced in *Escherichia coli*. *Proc Natl Acad Sci USA* 85:5879–5883
16. Lei X, Ahn K, Zhu L, Ubarretxena-Belandia I, Li YM (2008) Soluble oligomers of the intramembrane serine protease YggP are catalytically active in the absence of detergents. *Biochemistry* 47:11920–11929
17. Zanier K, Nomine Y, Charbonnier S, Ruhlmann C, Schultz P, Schweizer J, Trave G (2007) Formation of well-defined soluble aggregates upon fusion to MBP is a generic property of E6 proteins from various human papillomavirus species. *Protein Expr Purif* 51:59–70
18. Nomine Y, Ristriani T, Laurent C, Lefevre JF, Weiss E, Trave G (2001) Formation of soluble inclusion bodies by hpv e6 oncoprotein fused to maltose-binding protein. *Protein Expr Purif* 23:22–32

Chapter 11

Construction and Production of an IgG-Like Tetravalent Bispecific Antibody, IgG–Single-Chain Fv Fusion

Dan Lu and Zhenping Zhu

Abstract

In recent years, both laboratory and clinical studies have demonstrated that bispecific antibodies (BsAbs) may have significant potential application in cancer therapy either by targeting tumor cells with cytotoxic agents including effector cells, radionuclides, drugs, and toxins, or by simultaneously blocking two tumor-associated targets, e.g., tumor growth factors and/or their cell surface receptors. A major obstacle in the development of BsAb has been the difficulty of producing the materials in sufficient quality and quantity by traditional technologies such as the hybrid hybridoma and chemical conjugation methods. The development of recombinant BsAbs as therapeutic agents will depend heavily on the advances made in the design of the constructs (or formats) and production efficiency. Here we describe a recombinant method for the construction and production of a tetravalent IgG-like BsAb molecule, IgG–scFv fusion, in which, a single-chain Fv (scFv) antibody fragment of one antigen specificity is genetically fused to the c-terminal of a conventional IgG of a different antigen specificity.

Key words Antibody engineering, Bispecific antibody, Single-chain variable fragment (scFv), Recombinant antibody, Antibody production, Cancer therapy

1 Introduction

Monoclonal antibodies (mAbs) have become a major class of therapeutic agents providing effective alternatives to the treatment of various human diseases. Unfortunately, all current approved mAbs are not sufficiently effective when used as a single agent in particular in the treatment of cancer. Bispecific antibodies (BsAbs) are antibody-based molecules that can simultaneously bind two separate and distinct antigens on the same or different cells, or different epitopes of the same antigen [1–5]. The early development of BsAb has been to redirect cytotoxic immune effector cells for enhanced killing of tumor cells. In this context, one arm of the BsAb binds an antigen on tumor cells and the other binds a determinant expressed on effector cells, such as CD3, CD16, or CD64, which are expressed on T lymphocytes, natural killer (NK) cells,

or other mononuclear cells [6, 7]. By cross-linking tumor and effector cells, the BsAb not only brings the effector cells within the proximity of the tumor cells but also simultaneously triggers their activation, leading to effective tumor cell killing. Catumaxomab, the first BsAb of this class (against CD3 and EpCAM) was approved in Europe in 2009 [8]. Recently, BsAbs have been developed to target two tumor-associated molecules, e.g., two tumor growth factors and/or their cell surface receptors [9]. By simultaneously targeting two different targets or two different epitopes on the same target, BsAb therapy may lead to downregulation of multiple distinct cell proliferation/survival pathways, resulting in enhanced antitumor activity [10–14].

A major obstacle in the successful development of BsAb has been the difficulty of producing the materials in sufficient quality and quantity for both preclinical and clinical studies. In the recent years, advancement in recombinant antibody engineering technologies has provided significant boost to the development of BsAb. Today, more than 35 BsAb formats, including both fragment-based and full IgG-like molecules, have been published [15, 16]. Compared to the small-size BsAb fragments, IgG-like BsAbs, which contain a full-length IgG Fc fragment, are designed to have IgG-like long serum half-lives as well as potential immune effector functions, i.e., antibody-dependent cellular cytotoxicity (ADCC) and complement-mediated cytotoxicity (CMC) [16]. One format of this class BsAb (Fig. 1), IgG–scFv fusion, in which an scFv of one antigen specificity is fused to the c-terminal of a conventional IgG of a different antigen specificity, attracted significant attentions recently [12–14, 17] (*see Note 1*). Here we describe a recombinant method for the construction and production of a novel fully human, tetravalent IgG–scFv BsAb molecule

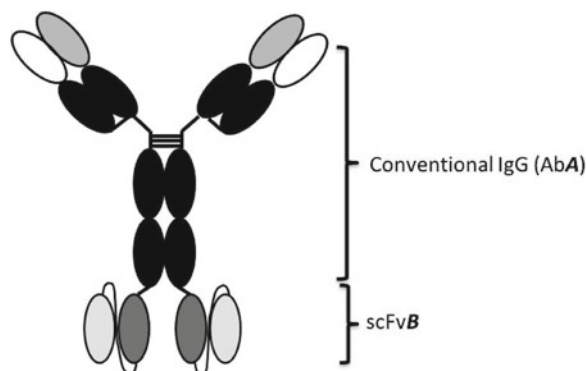

Fig. 1 Schematic diagram of the tetravalent IgG–scFv BsAb. The conventional IgG is from FabA against target 1; the single-chain Fv (scFv) is from FabB against target 2

against two tumor-associated targets, referred as target 1 and target 2, in the entire text in this chapter.

2 Materials

2.1 Generation of the IgG-scFv BsAb Expression Vector

Note: Molecular biology grade or analytic reagents and purified, autoclaved, or MQ water should be used in all the procedures.

2.1.1 General Reagents and Equipment

1. DNA purification kit.
2. PCR kit, for example, Accuprime™ Taq DNA Polymerase High Fidelity and Platinum™ Blue PCR SuperMix (Invitrogen, Carlsbad, CA).
3. PCR product purification kit.
4. Gel extraction or cleanup kit.
5. NanoDrop photometer.
6. Centrifuge with swinging-bucket rotor.
7. Bacteria incubator/Shaker.
8. Thermocycler.
9. Microcentrifuge.
10. Consumable lab wares such as sterilized 0.20- μ l PCR tubes, strips, 96-well PCR plate, sealing film, 100 mm polystyrene petri dishes, sterile 1.5-ml microcentrifuge tubes, 14-ml bacteria culture tube, razor blades, and sterile 0.22- μ m filter.
11. Chemical reagents such as 200 proof ethanol, agarose, agar, ampicillin, and LURIA broth base (LB) medium.
12. Electrophoresis devices.
13. Different percentage of precast E-gel.
14. E-gel® ibase™ Power System.
15. SYBR® Green I nucleic Acid Gel Stain or Ethidium bromide solution, 20 \times TAE, 6 \times DNA loading buffer and 1 kb plus DNA ladder.
16. Ampicillin store solution: 1-ml aliquots of 100 mg/ml in 0.22- μ m-filter sterilized water. Store at -20°C .
17. LBA plate: add 15 g agar to 1 L of LB medium and autoclave. After the medium cools down to 50–60 $^{\circ}\text{C}$, add ampicillin to a final concentration of 100 $\mu\text{g}/\text{ml}$. Mix and pour plates quickly.
18. Quick T4 DNA ligase kit, digestion enzyme *Apa*LI, *Asc*I, *Mfe*I, *Nhe*I, and *Bcl*I (NewEngland BioLabs, Beverly, MA).
19. Chemically competent cells, for example, One Shot® Mach1™ T1 Phage-Resistant *E. coli* cells and One Shot® MAX Efficiency™ DH5 α -T1® *E. coli* (Invitrogen).

2.1.2 Vector for Cloning and Expression

1. pCR[®]2.1-TOPO Vector (Invitrogen).
2. pBh1f Vector (a vector licensed from Dyax Corporation): an expression vector containing genes encoding the human IgG1 heavy chain constant domains (partial CH1, CH2, and CH3), and Neo for stable expression cell line selection. It also includes a 19-amino-acid-long natural leader from human IgG heavy-chain subgroup II, MGWSCIILFLVATATGVHS, which directs the newly synthesized protein to the secretory pathway. Gene expression is regulated by CMV promoter.
3. pShuttle VI vector (a vector licensed from Dyax Corporation): a vector containing IRES motif (internal ribosome entry site).

2.1.3 Primers for Amplification, Cloning, and Sequence

1. PCR primers to amplify heavy chain and light chain variable domain of antibody (underline nuclear acid compliment to either 5' or 3' of variable domain of antibody **B** (**AbB**)):
 - (a) Primers to amplify heavy chain variable domain.
 $V_H\mathbf{B}_{fow}$: 5' CTC TCC CTG TCT CCG GGT NNN NNN NNN NNN 3'.
 $V_H\mathbf{B}_{rew}$: 5' GCC AGA GCC CCC TCC GCC TGA ACC GCC TCC ACC GCT TGA GAC GGT GAC 3'.
 - (b) Primers to amplify light chain variable domain.
 $V_L\mathbf{B}_{fow}$: 5' GGC GGA GGG GGC TCT GGC GGT GGC GGA TCG NNN NNN NNN NNN NNN 3'.
 $V_L\mathbf{B}_{rew}$: 5' TGA TCA TTA NNN NNN NNN NNN NNN 3' (*with BclI site and 2 stop codons*).
2. PCR primers to append scFv**B** to the c-terminal of IgG-CH3:
 - (a) Primers to amplify scFv**B**: $V_H\mathbf{B}_{fow}$ and $V_L\mathbf{B}_{rew}$.
 - (b) Primers to amplify constant domain of IgG-Fc:
 C_H_{fow} : 5' TCC ACC AAG GGC CCA TCG GT 3'.
 C_H_{rew} : 5' ACC CGG AGA CAG GGA GAG GCT CTT 3'.
3. PCR primers for screening the insert in pBh1f vector:
 $CMVfwdprom$: 5' CGCAAATGGGCGGTAGGCCGTG 3'.
 $BatchColREV$: 5' CGCCTGAGTTCCACGACACCGTCAC 3'.
4. Sequence primers:
 - (a) Primers to sequence scFv in pCR[®]2.1-TOPO Vector:
 $M13$ forward: 5' GTAAAACGACGGCCAG 3'.
 $M13$ reverse: 5' CAGGAAACAGCTATGAC 3'.
 - (b) Primers to sequence insert in pBh1f vector:
 $BatchSeqFWD$: 5' AGCAGGCTTGAGGTCTGGAC 3' for light chain variable domain.

BatchSeqREV: 5' TCGGGGAAGTAGTCCTTGAC 3' for heavy chain variable domain.

(c) Primers to sequence Fc-scFv fragment in pBh1 vector:

IRES_seqFow: 5' CACAGGCGTGCCTCTAAGG 3' for IgG1 heavy chain constant domain.

C_H1_seqFow: 5' ACCAAGGGCCCATCGGTCTT 3' for IgG1 heavy chain constant domain.

C_H3_seqFow: 5' TATCCCAGCGACATCGCCGT 3' for appended scFv.

pBh1f_seqRew: 5' AGATGGCTGGCAACTAGAAG 3' for appended scFv.

2.2 Expression and Purification of the IgG-scFv BsAb

2.2.1 Expression of the IgG-scFv BsAb

1. FreeStyle™ MAX 293 Expression System with FreeStyle™ 293-F Cells, FreeStyle™ MAX Reagent, FreeStyle™ 293 Expression Medium and OptiPro™ SFM (Invitrogen).
2. Orbital shaker in 37 °C incubator with a humidified atmosphere of 8 % CO₂.
3. Large-scale DNA purification kit.
4. Polycarbonate, disposable, sterile Erlenmeyer flask with vented cap.
5. Trypan blue stain.
6. Coulter Counter or hemacytometer.
7. Microscope.

2.2.2 Purification of the IgG-scFv BsAb

1. Hitrap™ rProtein A FF column (GE Healthcare, Piscataway, NJ).
2. Pump.
3. Dialyze cassette.
4. NuPAGE® LDS sample buffer, NuPAGE® LDS sample reducing agent, NuPAGE® Antioxidant, seeBlue® Plus2 Pre-Stained Standard, NuPAGE® MES SDS running buffer (20×), NuPAGE® LDS 4–12 % Bis-Tris Gel (1.5 mm × 10 well) and Gel staining buffer (Invitrogen).
5. XCell SureLock™ mini-Cell (Invitrogen).

2.3 Binding ELISA

1. Recombinant protein of target 1 and 2, human anti-target 1 antibody *A* (Ab*A*) and human anti-target 2 antibody *B* (Ab*B*), are produced internally at Kadmon Corporation.
2. Biotin-labeled target 2 protein: Label target 2 protein by using a Biotinylation Kit such as EZ-Link® Sulfo-NHS-Biotin following manufacturer's protocol (ThermoFisher).
3. Streptavidin–HRP conjugated.
4. PBS solution sterile-filter through 0.45-µm filter.
5. No-fat milk.

6. Blocking buffer: PBS containing 3 % milk (3 % PBSM); add 3 g no-fat milk to 100 ml of PBS and mix.
7. 96-well ELISA plates.
8. Plate sealer.
9. Tween 20.
10. Washing buffer (PBST, 0.1 %): Add 1 ml of Tween 20 to 1,000 ml of PBS and mix.
11. Goat antihuman IgG Fab-specific antibody–HRP.
12. TMB peroxidase substrate.
13. Stop solution: 1 N H₂SO₄ diluted from 36 N H₂SO₄.
14. Plate reader.

3 Methods

Two fully human antibody Fab fragments, FabA and FabB, were isolated by screening a human Fab fragment phage-display library [18, 19], licensed from Dyax Corporation (Burlington, MA), containing 3.7×10^{10} unique clones, against target 1 and target 2, respectively, according to the instruction provided by Dyax Corporation. Antibodies isolated from the libraries can be used as the building blocks for BsAb construction, often directly, or in some instance, after affinity maturation [20].

The stability of the parent antibodies, especially that of the scFv used for IgG-scFv BsAb construction, is often the key for the successful expression/purification, as well as the stability/solution behavior of this type of BsAb [12–14]. Much effort have been attempted to stabilize the scFv fragments, including introducing a disulfide bond between the heavy chain variable (VH) and the light chain variable domain (VL) of scFv [21] and grafting the CDRs to a stable frameworks [22]. ScFv libraries were built by using a combination of sequence-based statistical analysis and structure-/knowledge-based methods [22–24] or shuffling the VL and the VH domains based on the Dyax libraries repertoire [25, 26], then screening at higher temperature or other more stringent conditions to identify the stable variants. Many studies indicated that the stability of scFv heavily depends upon its primary structure, i.e., the amino acid sequence of the scFv. In addition, it has been shown that the linker between the scFv and IgG CH3 domain also affects significantly the stability and solution behavior of the IgG-scFv BsAb constructs [12] (*see Note 2*).

In construction of the IgG-scFv BsAb molecule, FabA is first reformatted to a conventional IgG (AbA). The VH and VL domains of FabB are cloned and assembled into an scFv (scFvB) in the orientation, VH-[(Gly)₄Ser]₃-VL, and scFvB is then fused to the c-terminal of AbA IgG CH3 domain (Fig. 2) (*see Notes 1 and 2*).

The IgG-scFv produced in this method is purified by one-step Protein A affinity chromatography and retained high binding affinity to both target 1 and target 2 (Figs. 3 and 4). This IgG-scFv is also very stable as analyzed by differential scanning calorimetry

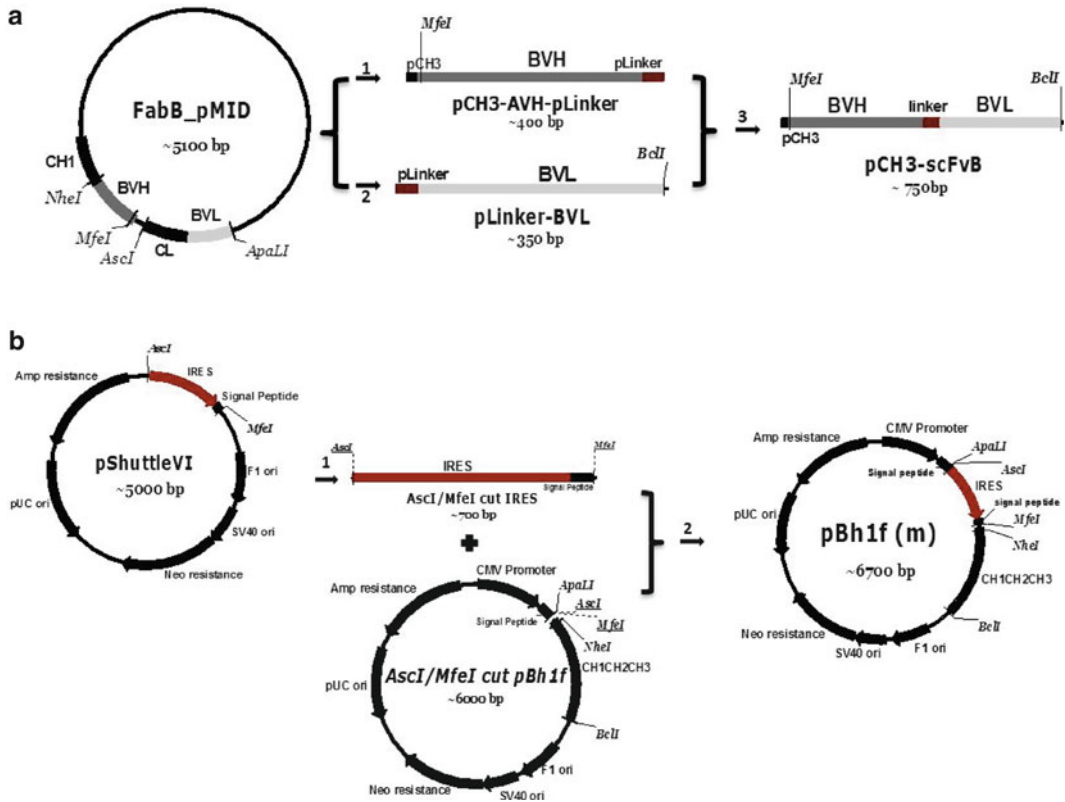
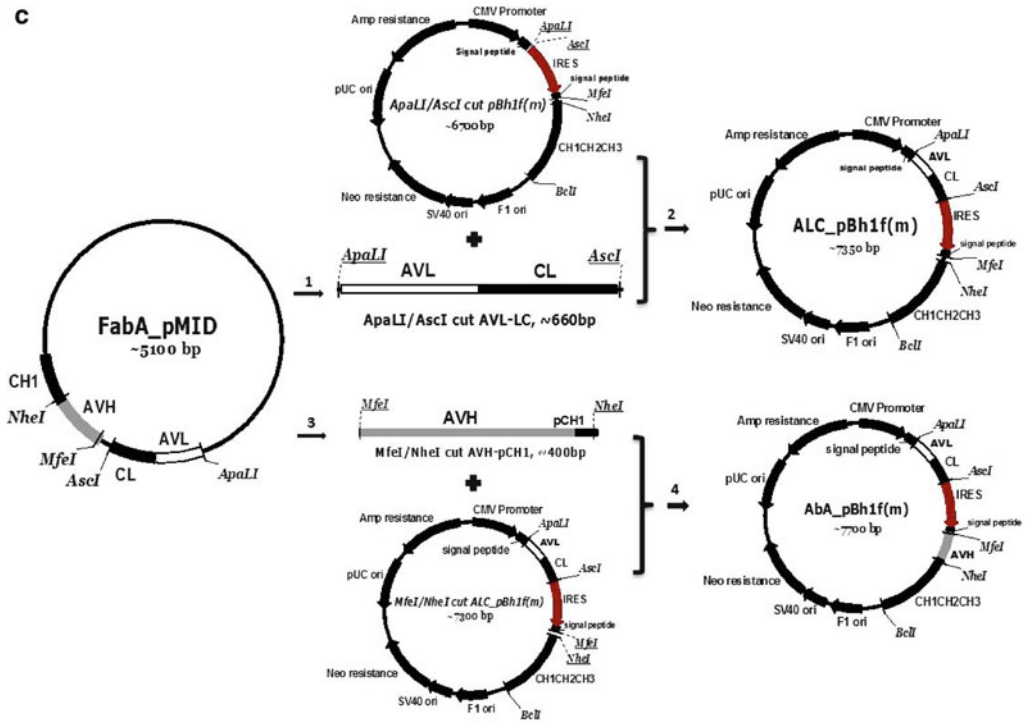

Fig. 2 Scheme of IgG-scFv BsAb construction. **(a)** Assembling of scFvB: (1) Amplification of the heavy chain variable domain (BVH) from FabB_pMid vector; (2) Amplification of the light chain variable domain (BVL) from FabB_pMid vector; (3) Assembling of BVH and BVL into single-chain Fv (scFvB). Partial CH3 and *BclI* site are present in this construct for the subsequent cloning of scFvB to the c-terminal of the conventional IgG AbA. **(b)** Modification of the mammalian expression vector pBh1f. *AscI/MfeI* digestion (1) to release IRES from vector pShuttle VI followed by insertion (2) into the *AscI/MfeI*-cut pBh1f vector. The modified pBh1f vector, which is called pBh1f(m), is used for the IgG-scFv BsAb construction. **(c)** Reformatting of FabA to IgG AbA: (1) *ApaLI/AscI* digestion to release the light chain of AbA (ALC) from FabA_pMID vector; (2) Ligation of the *ApaLI/AscI*-cut ALC to *ApaLI/AscI*-cut pBh1f(m) vector to form ALC_pBh1f(m). (3) *MfeI/NheI* digestion to release the heavy chain variable domain of AbA (AVH) and partial CH1 from FabA_pMID vector; (4) Ligation of the *MfeI/NheI*-cut AVH-pCH1 to the *MfeI/NheI*-cut ALC_pBh1f(m) vector to form AbA_pBh1f(m) vector. **(d)** Construction of the IgG-scFv BsAb: (1) Amplification of IgG1 heavy chain constant domain (pCH1-CH2-CH3) from pBh1f(m) vector; (2) Assembling of pCH1CH2CH3 and pCH3-scFvB to pCH1CH2CH3-scFvB. (3) Ligation of the *NheI/BclI*-cut pCH1CH2CH3-scFvB to the *NheI/BclI*-cut AbA_pBh1f(m) vector to form the final IgG-scFv expression vector, IgG-scFv_pBh1f(m)

c



d

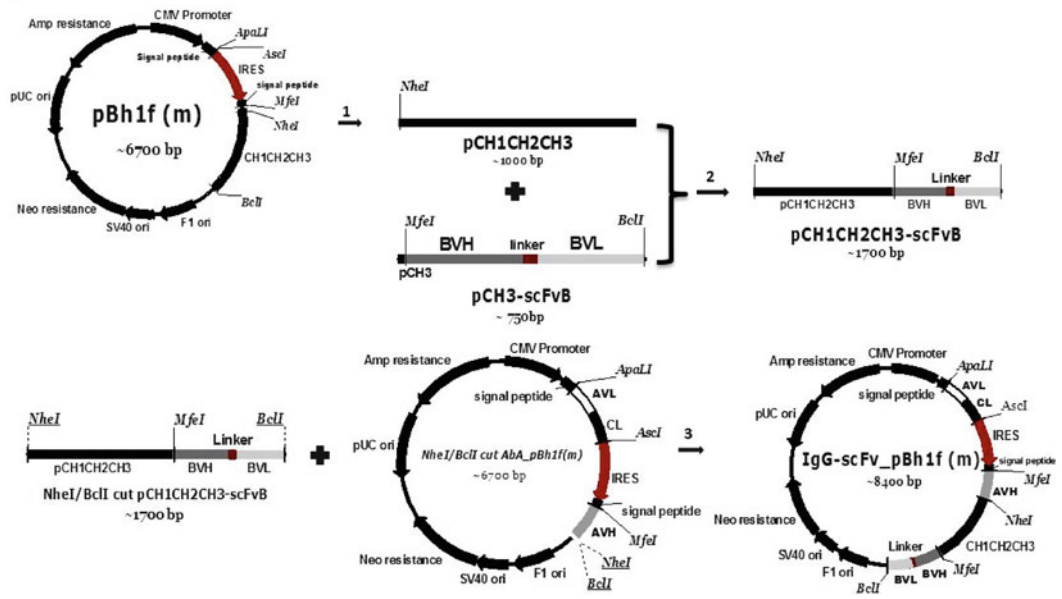

Fig. 2 (continued)

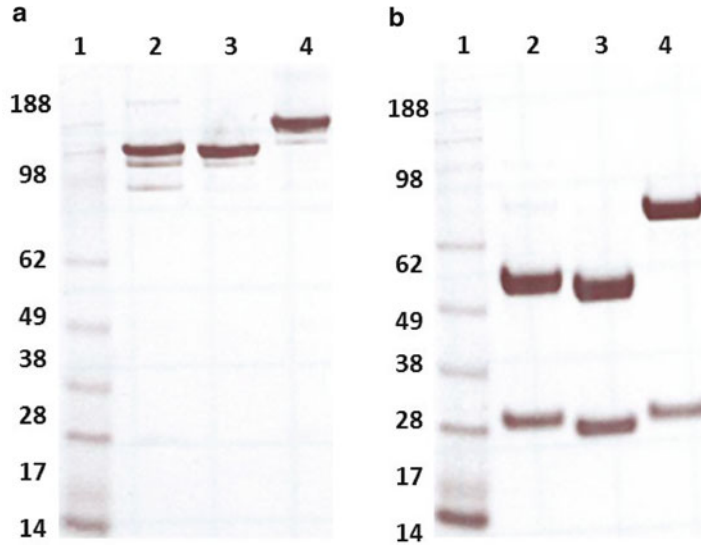

Fig. 3 SDS-PAGE analysis of the purified IgG-scFv BsAb. The purified IgG-scFv BsAb was analyzed by gel electrophoresis under both nonreduced (**a**) and reduced (**b**) conditions. *Lane 1*, molecular weight standards; *Lane 2*, Ab**A**, the Ig form of Fab**A**; *Lane 3*, Ab**B**, the Ig form of Fab**B**; *lane 4*, the IgG-scFv BsAb. Note that the IgG-scFv BsAb yielded a single protein band of ~200 kDa under nonreducing conditions, and two bands of ~75 kDa (the heavy chain–scFv fusion) and ~25 kDa (the light chain) under reducing conditions, whereas both Ab**A** and Ab**B** yields a single band of ~150 kDa under nonreducing conditions, and two bands of ~50 kDa (the heavy chain) and ~25 kDa (the light chain) under reducing conditions

(DSC) and size exclusion chromatography (T_m for scFv**B** is 65 °C and >90 % is monomer, data not showed).

Since many different restriction enzymes are used during the cloning process, it is possible that some of these enzymes are not comparable with the variable domain nucleotide sequences of the antibodies, thus in some cases silent mutagenesis are performed to delete these enzyme digestion sites.

3.1 Assembling of the scFvB (Fig. 2a)

3.1.1 Amplification of the VL and the VH Gene of AbB

1. Design primers to amplify the VH and the VL genes of Ab**B**.
 - (a) There are two different V domain orientations in assembling VH and VL genes into scFv fragment, VH-linker-VL, or VL-linker-VH. Both orientations have been described in the literature and in most cases have led to active scFv proteins [27]. It has also been reported that, depending upon the primary sequence of the V genes, however,

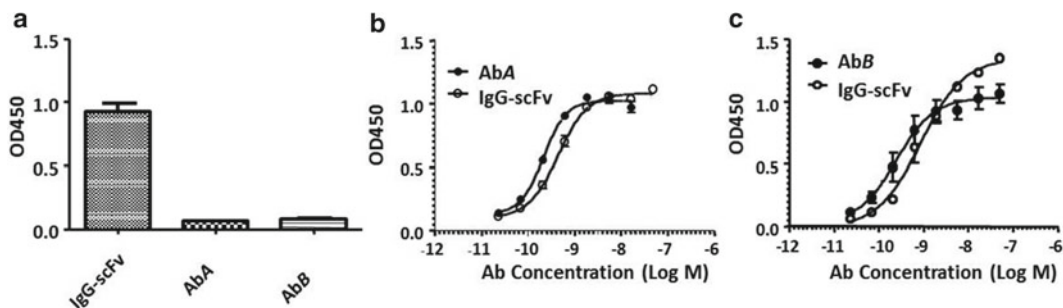

Fig. 4 Bispecific and dose-dependent binding of the IgG-scFv BsAb to target 1 and target 2 as determined by ELISA. **(a)** Target cross-linking assay: the IgG-scFv BsAb, but not the monospecific parent antibodies, is capable of cross-linking the two targets. **(b, c)** Dose-dependent binding to immobilized target 1 and target 2 by the IgG-scFv BsAb and its parent antibodies. The IgG-scFv BsAb binds to both target 1 and target 2, whereas the monospecific parent antibodies only react with their respective targets. **AbA**, the IgG form of FabA; **AbB**, the IgG form of FabB. Data shown represent the mean \pm SD of triplicate determinations

different V domain orientation may cause difference in expression and antigen-binding activity of the resultant scFv [27]. In this protocol, we chose to construct the scFv in VH-linker-VL orientation, and designed the primers accordingly for V gene cloning (Fig. 2a).

- (b) The linker between the VH and the VL also affect the stability and production of the scFv and the final BsAb. The most commonly used linker is $[(\text{Gly})_4\text{Ser}]_n$ ($n = 3-4$). In this method, the 3' primer of VH and 5' primer of VL each contain a nucleotide sequence encoding a 10-amino-acid-long linker, $[(\text{Gly})_4\text{Ser}]_2$. The two primers are complement to each other for 15 nucleotides, thus the linker becomes 15-amino-acid long, $[(\text{Gly})_4\text{Ser}]_3$, after assembling the VH and VL genes into scFv format.
- (c) It is important to design the 5' and 3' primers for the amplification of the VH and the VL genes based on the nucleotide sequences of the parent antibodies. It is recommended to synthesize the 5' primers that are complement to the first 15 nucleotides of the VH or the VL, and to synthesize the 3' primers that are complement to the last 15 nucleotides of the VH or the VL.
- (d) The first 18 nucleotides of $V_H\mathbf{B}_{\text{fow}}$ are complement to the c-terminal of IgG constant domain to facilitate the assembling of Fc-scFv fusion.
- (e) Primer of $V_L\mathbf{B}_{\text{rew}}$ has a *BclI* site, which facilitates insertion of pCH1CH2CH3-scFvB into the expression vector, and two stop codons, which direct the expression of correct-size IgG-BsAb.

- (f) Several other important factors to consider in primer designing include the size of primer, T_m , GC%, and secondary structure.
2. Prepare solution I to amplify the VH gene and solution II to amplify the VL gene:

Solution I

10× AccuPrime™ PCR buffer I	5 μ l
50 ng purified DNA from FabB_pMID21 (<i>see Note 3</i>)	$x\mu$ l
20 pmol of $V_H B_{fow}$	$x\mu$ l
20 pmol of $V_H B_{rew}$	$x\mu$ l
0.2 U AccuPrime™ Tag High Fidelity (<i>see Note 4</i>)	0.2 μ l
Add H ₂ O to a total volume of mix, briefly	50 μ l

Solution II

10× AccuPrime™ PCR buffer I	5 μ l
50 ng purified DNA from FabB_pMID21	$x\mu$ l
20 pmol of $V_L B_{fow}$	$x\mu$ l
20 pmol of $V_L B_{rew}$	$x\mu$ l
0.2 U AccuPrime™ Tag High Fidelity	0.2 μ l
Add H ₂ O to a total volume of mix, briefly	50 μ l

3. Program the thermocycler as follows (*see Note 5*):
- Initial denaturation: 94 °C for 30 s
- 30 cycles of: 94 °C for 30 s, 55 °C for 30 s, 68 °C for 30 s
- Final extension: 72 °C for 10 min
4. Place the PCR tubes into the thermocycler and run the above program.

3.1.2 Purification of the VH and the VL Genes of AbB

1. Prepare a 1.5 % agarose gel with SYBR®Green or Ethidium bromide by using TAE buffer. The wells should be sufficient to accommodate 50 μ l samples.
2. Add 10 μ l 6× loading buffer to the PCR products. Load about 50 μ l samples to each well. Also load 10 μ l 1-kb DNA ladder (0.1 μ g/ μ l) in the standard well.
3. Electrophoresis in TAE buffer until the dye front migrates approximately two-thirds the length of the gel. Photograph the gel under UV light.

4. Use a razor blade carefully to excise the 350-bp (*p*Linker-*BVL*) and 400-bp (*p*CH3-AVH-*p*Linker) bands (*see Note 6*).
5. Use QiagenQIAquick1 Gel Extraction Kit (*see Note 7*) to purify DNA fragments following the manufacturer's instructions.
6. Measure the DNA fragment concentrations by using Nano-Drop photometer.

3.1.3 Assembling of the VH and the VL Genes from AbB into scFv (scFvB)
(*See Note 8*)

1. Add the following materials to a PCR tube:

10× AccuPrime™ PCR buffer I	5 μl
<i>p</i> CH3- <i>BVH</i> - <i>p</i> Linker fragment (44 ng)	<i>x</i> μl
<i>p</i> Linker- <i>BVL</i> fragment (50 ng)	<i>x</i> μl
0.2 U AccuPrime™ Tag High Fidelity	0.2 μl
Add H ₂ O to a total volume of mix, briefly	50 μl

2. Place the tube in the thermocycler and run the following program for 15 cycles:
94 °C for 1 min, 63 °C for 3 min.
3. Add the following to the assembling tube in the above step:

10× AccuPrime™ PCR buffer I	5 μl
20 pmol V _H <i>B</i> _fow	<i>x</i> μl
20 pmol V _L <i>B</i> _rew	<i>x</i> μl
0.2 U AccuPrime™ Tag High Fidelity	0.2 μl
Add H ₂ O to a total volume of mix, briefly	50 μl

4. Return the tube to the thermocycler and run a program consisting of 30 cycles of 94 °C for 30 s, 55 °C for 30 s, and 68 °C for 1 min, and followed by an extension at 72 °C for 10 min.
5. Analyze 5 μl of the PCR product on a 1.2 % E-gel. A predominant band in the size of ~750 bp should present (*see Note 9*).

3.1.4 Sequencing the scFv DNA Fragment of AbB (scFvB)

There are several more steps to clone the scFvB DNA fragments into the eukaryotic expression vector for the production of the final IgG-scFv BsAb. To reduce the risk of carrying over PCR error to the next experiment, it is recommended to clone the assembled scFv fragment into pCR®2.1-TOPO® Vector (*see Note 10*) and sequence the entire scFv fragment (*see Notes 11 and 12*).

1. Prepare the following solution to ligate the assembled *pCH3-scFvB* fragment into *pCR[®]2.1-TOPO[®]* vector:

Fresh <i>pCH3-scFvB</i> PCR product, ~750 bp	0.5–4 μ l
Salt solution	1 μ l
<i>pCR[®]2.1-TOPO[®]</i> vector	1 μ l
Add H ₂ O to a total volume of mix, briefly	6 μ l

2. Incubate at RT for 5 min. Centrifuge briefly and place on ice.
3. Thaw a vial of One Shot1 DH5[™]-T1[®] cell on ice. Pipette 2 μ l of the ligation reaction into cells and stir gently with pipette tip to mix.
4. Incubate the vial on ice for 30 min. Heat shock for exactly 30 s in 42 °C water bath. Do not mix; place the vial on ice for 2 min.
5. Add 250 μ l of prewarmed SOC medium to the vial. Shake the vial at 37 °C in a shaker at 225 rpm for 1 h.
6. Plate 10–200 μ l of cells from the above transformation vial on the LB plates containing 100 μ g/ml ampicillin and X-Gal. Incubate the plates at 37 °C for at least 18 h. Shift the plates to 4 °C for 2–3 h for color development (*see Note 13*).
7. Inoculate 10–12 white colonies into individual 15-ml Snap-On tube containing 5 ml LBA. Shake the tube at 37 °C in a shaker at 225 rpm overnight.
8. Purify plasmid DNA according to the instruction provided by manufacturer. Sequence the insert by using primer M13 forward and primer M13 reverse. Pick clones with correct sequence and continue to the next experiments (*see Note 14*).

3.2 Modification of the IgG Expression Vector *pBh1f* (Fig. 2b); Addition of IRES to *pBh1f* Vector

IgG expression vector, *pBh1f*, from Dyax Corporation is used for BsAb expression. The vector has several important mammalian expression components such as a eukaryotic leader sequence, a CMV promoter, and a Neo resistance gene. The constant domain genes, CH1, CH2, and CH3, of IgG1 are also present in *pBh1f* vector. In this step, an IRES motif (internal ribosome entry site) from encephalomyocarditis virus (ECMV), which mediates the mRNA translation, was cut from the *pShuttle VI* vector and cloned into the *pBh1f* vector.

3.2.1 Release of IRES from pShuttle VI

1. Prepare the following solutions for *AscI*/*MfeI* digestion (*see* **Note 15**):

5 µg of purified DNA of pShuttle VI	xµl
10× NEB buffer 4	5 µl
100× NEB BSA	0.5 µl
10 units of <i>AscI</i>	1 µl
10 units of <i>MfeI</i>	1 µl
Add H ₂ O to a total volume of mix, briefly	50 µl

2. Incubate the above solution at 37 °C for 3–4 h.
3. Prepare 1.0 % agarose gel and purify IRES fragment (~700 bp) as described in Subheading 3.1.2. Resuspend the DNA fragment in 30 µl of MQ H₂O.
4. Measure the DNA concentration by Nano drop photometer.

3.2.2 Preparation of pBh1f Vector

1. Prepare the following solutions for *AscI*/*MfeI* digestion:

5 µg of purified DNA of pBh1f	xµl
10× NEB buffer 4	5 µl
100× NEB BSA	0.5 µl
10 units of <i>AscI</i>	1 µl
10 units of <i>MfeI</i>	1 µl
Add H ₂ O to a total volume of mix, briefly	50 µl

2. Incubate the above solution at 37 °C for 3–4 h.
3. Prepare 1.0 % agarose gel and purify pBh1f vector (~6.0 kb) as described in Subheading 3.1.2. Resuspend the DNA fragment in 30 µl of MQ H₂O.
4. Measure the DNA concentration by Nano drop photometer.

3.2.3 Ligation of IRES to pBh1f Vector

1. Prepare the ligation reaction to insert the IRES to pBh1f vector (*see* **Notes 16** and **17**):

50 ng of <i>AscI</i> / <i>MfeI</i> digested pBh1f	xµl
50 ng of <i>AscI</i> / <i>MfeI</i> released IRES insert ^a	xµl
2× NEB Quick ligation buffer	10 µl
Add H ₂ O to a total volume of mix, briefly	20 µl

^aPrepare a control ligation mixture in a separate 1.5-ml Eppendorf tube by replacing the purified *AscI*/*MfeI* digested IRES fragment with H₂O

2. Add 1 μl of Quick T4 DNA Ligase and mix thoroughly. Centrifuge briefly and incubate at room temperature (25 °C) for 5 min. Chill on ice. This newly ligated vector is renamed as pBh1f(m) (~6,700 bp).

3.2.4 Transformation of *E. coli* with pBh1f(m) Plasmids (See Note 18)

1. Equilibrate a water bath to 42 °C.
2. Warm the vial of SOC medium (come with the cells) to RT and LBA plates at 37 °C for 30 min.
3. Thaw on ice one vial of One Shot[®] Mach1[™] T1 Phage-Resistant cell for each transformation.
4. Add 2–5 μl ligated solutions into the competent cells and mix gently. Incubate on ice for 20 min.
5. Heat-shock the cells for 30 s at 42 °C without shaking.
6. Immediately transfer the vials to ice. Incubate the vial in ice for 2 min.
7. Add 250 μl of RT SOC medium. Cap the vials tightly and shake the tube horizontally (225 rpm) at 37 °C for 1 h.
8. Spread a 25–100 μl of cells from each transformation on a pre-warmed LBA plate.
9. Incubate plates at 37 °C overnight or until the colonies present.

3.2.5 PCR Screening for Colonies with the Right Insert

1. Prepare the following PCR reaction mixture (for ten reaction):

50 pmol of CMVfwdprom	$x\mu\text{l}$
50 pmol of BatchColREV	$x\mu\text{l}$
Platinum [®] Blue PCR SuperMix (Invitrogen)	225 μl
Add H ₂ O to a total volume of mix, briefly	250 μl

2. Program the thermocycler as follows:
Initial denaturation: 94 °C for 30 s
30 cycles: 94 °C for 30 s; 55 °C for 30 s; 68 °C for 60 s
Final extension: 72 °C for 10 min.
3. Aliquot 25 μl PCR reaction mixture to each well of a PCR plate or strip.
4. Seal the PCR reaction plate/strip and place the plate/strip to the thermocycler and run the above program.
5. Load 15 μl PCR sample to 1.0 % E-gel. Electrophoresis for about 15 min. Take the picture under UV light. The colonies with insert should have a 1.1-kb band.

- Purify plasmid DNA according to the manufacturer's instruction and measure the concentration by using Nano-drop.
- Sequence to confirm by using primer BatchSeqFWD and BatchSeqREV.

3.3 Reformatting of FabA to Conventional IgG, AbA (Fig. 2c)

Antibody *A* against target 1 was identified in a Fab format from the Dyax Fab libraries. The Fab*A* is reformatted to a conventional IgG by inserting its whole light chain (*AVL*+*LC*, called *ALC*) to the pBh1f(m) vector first; its heavy chain variable domain with partial CH1 fragment (*AVH-pCH1*) is inserted to pBh1f(m) sequentially.

3.3.1 Insertion of the FabA Light Chain into pBh1f(m) Expression Vector

- Purify significant amount plasmid DNA of Fab*A*_pMID and pBh1f(m) according to the instruction provided by manufacture. Measure the DNA concentration by Nano-drop.
- Prepare the *ApaLI/AscI* digestion solution in two 1.5 ml Eppendorf tubes for Fab*A*_pMID and vector pBh1f(m):

5 µg of purified DNA of Fab <i>A</i> _pMID or pBh1f(m)	<i>x</i> µl
10× NEB buffer 4	5 µl
100× NEB BSA	0.5 µl
10 units of <i>ApaLI</i>	1 µl
10 units of <i>AscI</i>	1 µl
Add H ₂ O to a total volume of mix, briefly	50 µl

- Incubate the above solution at 37 °C for 3–4 h.
- Prepare 1.0 % agarose gel and purify the released Ab*A* light chain fragment (*ALC*) and pBh1f(m) vector as described in Subheading 3.1.2. The correct *ALC* fragment size is about ~660 bp and the pBh1f(m) size is about 6.7 kb. Resuspend the DNA fragments in 30 µl of MQ H₂O.
- Prepare ligation reaction in two Eppendorf 1.5-ml tubes as following:

50 ng of <i>ApaLI/AscI</i> digested pBh1f(m)	<i>x</i> µl
20 ng of <i>ApaLI/AscI</i> released <i>ALC</i> fragment ^a	<i>x</i> µl
2× NEB Quick ligation buffer	10 µl
Add H ₂ O to a total volume of mix, briefly	20 µl

^aPrepare a control ligation mixture in a separate 1.5 ml Eppendorf tube by replacing the purified *ApaLI/AscI* released *ALC* fragment with H₂O

Add 1 µl of Quick T4 DNA Ligase and mix thoroughly. Centrifuge briefly and incubate at room temperature (25 °C) for 5 min. Chill on ice.

6. Perform the transformation as described in Subheading 3.2.3.
7. Perform PCR screening as described in Subheading 3.2.4. The clone with correct insert should have 1.8-kb band. This construct is called *ALC_pBh1f(m)*.
8. Purify plasmid DNA according to the manufacturer's instruction. Measure the DNA concentration by Nano-drop.
9. Sequence to confirm by using primer BatchSeqFWD.

3.3.2 Insertion of the
FabA Heavy Chain Variable
Domain into
pBh1f(m) Vector

1. Prepare the *MfeI/NbeI* digestion solution in two 1.5-ml Eppendorf tubes for FabA_pMID and vector *ALC_pBh1f(m)*:

5 µg of purified DNA of FabA_pMID or <i>ALC_pBh1f(m)</i>	xµl
10× NEB buffer 4	5 µl
100× NEB BSA	0.5 µl
10 units of <i>MfeI</i>	1 µl
10 units of <i>NbeI</i>	1 µl
Add H ₂ O to a total volume of mix, briefly	50 µl

2. Incubate the above solution at 37 °C for 3–4 h.
3. Prepare 1.5 % agarose gel and purify the released AVH-*p*CHI fragment as described in Subheading 3.1.2. The correct AVH-*p*CHI fragment size is about ~400 bp. Resuspend the DNA fragment in 30 µl of MQ H₂O. Measure the DNA concentration by Nano-drop photometer.
4. Prepare 0.8 % agarose gel and purify the *MfeI/NbeI* digested *ALC_pBh1f(m)* as described in Subheading 3.1.2. The vector fragment size is about 7.4 kb. Resuspend the DNA fragment in 30 µl of MQ H₂O. Measure the DNA concentration by Nano-drop photometer.
5. Prepare ligation reaction in a 1.5-ml Eppendorf tubes as following:

50 ng of <i>MfeI/NbeI</i> digested <i>ALC_pBh1f(m)</i>	xµl
20 ng of <i>MfeI/NbeI</i> released AVH fragment ^a	xµl
2× NEB Quick ligation buffer	10 µl
Add H ₂ O to a total volume of mix, briefly	20 µl

^aPrepare a control ligation mixture in a separate 1.5-ml Eppendorf tube by replacing the purified *MfeI/NbeI* released AVH fragment with H₂O

6. Add 1 µl of Quick T4 DNA Ligase and mix thoroughly. Centrifuge briefly and incubate at room temperature (25 °C) for 5 min. Chill on ice.

7. Perform the transformation as described in Subheading 3.2.3.
8. Perform PCR screening as described in Subheading 3.2.4. The clone with correct insert should have 2.2 kb band. This construct is called AbA_pBhIf(m).
9. Purify plasmid DNA according to the manufacturer's instruction. Measure the DNA concentration by Nano-drop.
10. Sequence to confirm by using primer BatchSeqREW.

3.4 Construction of the IgG-scFv BsAb (Fig. 2d)

The CH1CH2CH3 constant domain of IgG1f and scFvB are amplified and assembled into Fc-scFv c-terminal fusion format (pCH1CH2CH3-scFvB). This fragment is digested with *NheI*/*BclI* and inserted into the conventional IgG AbA expression vector [AbA_pBhIf(m)] to make the IgG-scFv BsAb.

3.4.1 PCR Amplification of scFvB and the IgG1f Constant Domain pCH1CH2CH3

1. Prepare the following PCR reaction solution I to amplify scFvB and solution II to amplify IgG1f constant domain pCH1CH2CH3:

Solution I:

10× AccuPrime™ PCR buffer I	5 μl
50 ng purified DNA of scFvB_Topo2.1	x μl
20 pmol of V _H B_fow	x μl
20 pmol of V ₁ B_rew	x μl
0.2 U AccuPrime™ Tag High Fidelity	0.2 μl
Add H ₂ O to a total volume of mix, briefly	50 μl

Solution II:

10× AccuPrime™ PCR buffer I	5 μl
50 ng purified DNA of pBhIf	x μl
20 pmol of C _H _fow	x μl
20 pmol of C _H _rew	x μl
0.2 U AccuPrime™ Tag High Fidelity	0.2 μl
Add H ₂ O to a total volume of mix, briefly	50 μl

2. Program the thermocycler as follows:
 Initial denaturation: 94 °C for 30 s.
 30 cycles of: 94 °C for 30 s, 55 °C for 30 s, 68 °C for 60 s.
 Final extension: 72 °C for 10 min.

- Place the PCR tubes into the thermocycler and run the above program.
- Prepare a 1.0 % agarose gel to purify PCR product of scFvB (~750 bp) and IgG1f constant domain fragments (pCH1CH2CH3, ~1,000 bp) as described in Subheading 3.1.2. Resuspend the DNA fragments in 30 μ l of MQ H₂O. Measure the DNA fragment concentrations by using Nano-Drop photometer.

3.4.2 Assembling of the IgG1f Constant Domain and scFvB to pCH1CH2CH3-scFvB Fusion

- Add the following materials to a PCR tube:

10 \times AccuPrime™ PCR buffer I	5 μ l
scFvB fragment (37.5 ng)	$x\mu$ l
pCH1CH2CH3 fragment (50 ng)	$x\mu$ l
0.2 U AccuPrime™ Tag High Fidelity	0.2 μ l
Add H ₂ O to a total volume of mix, briefly	50 μ l

- Place the tube to the thermocycler and run the following program for 15 cycles:
94 °C for 1 min, 63 °C for 3 min.
- Add the following to the assembling tube in the above step:

10 \times AccuPrime™ PCR buffer I	5 μ l
20 pmol of C _H _fow	$x\mu$ l
20 pmol of V _L B_rew	$x\mu$ l
0.2 U AccuPrime™ Tag High Fidelity	0.2 μ l
Add H ₂ O to a total volume of mix, briefly	50 μ l

- Return the tube to the thermocycler and run a program consisting of 30 cycles of 94 °C for 30 s, 55 °C for 30 s, and 68 °C for 2 min, and followed by an extension at 72 °C for 10 min.
- Analyze 5 μ l of the PCR product on a 1.2 % E-gel. A predominant band in the size of ~1,700 bp should present. This is the assembled pCH1CH2CH3-scFvB fragment.

3.4.3 *NheI/BclI* Digestion of pCH1CH2CH3-scFvB and AbA_pBh1f(m) (See Note 19)

- Prepare the *NheI/BclI* digestion solution in two 1.5-ml Eppendorf tubes:

5 µg of purified DNA of <i>pCH1CH2CH3-scFvB</i> or <i>AbA_pBh1f(m)</i>	<i>x</i> µl
10× NEB buffer 4	5 µl
100× NEB BSA	0.5 µl
10 units of <i>BclI</i>	1 µl
10 units of <i>NheI</i>	1 µl
Add H ₂ O to a total volume of mix, briefly	50 µl

- Incubate at 37 °C for 2–3 h and then raise the temperature to 50 °C and continue to incubate for the other 2–3 h.
- Prepare 1.0 % agarose gel and purify *pCH1CH2CH3-scFvB* DNA fragment as described in Subheading 3.1.2. The correct fragment size is about 1.7 kb. Resuspend the DNA fragment in 30 µl of MQ H₂O. Measure the DNA concentration by Nano-drop photometer.
- Prepare 0.8 % agarose gel and purify the *NheI/BclI* digested *AbA_pBh1f(m)* as described in Subheading 3.1.2. The vector fragment size is about 6.9 kb. Resuspend the DNA fragment in 30 µl of MQ H₂O. Measure the DNA concentration by Nano-drop photometer.

3.4.4 Ligation of *pCH1CH2CH3-scFvB* to *AbA_pBh1f(m)* Vector

- Prepare ligation reaction in two 1.5 ml Eppendorf tubes as following:

50 ng of <i>NheI/BclI</i> digested <i>AbA_pBh1f(m)</i>	<i>x</i> µl
40 ng of <i>NheI/BclI</i> digested <i>pCH1CH2CH3-scFvB</i> fragment ^a	<i>x</i> µl
2× NEB Quick ligation buffer	10 µl
Add H ₂ O to a total volume of mix, briefly	20 µl

^aPrepare a control ligation mixture in a separate 1.5-ml Eppendorf tube by replacing the purified *NheI/BclI* digested *pCH1CH2CH3-scFvB* fragment with H₂O

- Add 1 µl of Quick T4 DNA Ligase and mix thoroughly. Centrifuge briefly and incubate at room temperature (25 °C) for 5 min. Chill on ice.
- Perform the transformation as described in Subheading 3.2.3.
- Perform PCR screening as described in Subheading 3.2.4. Here, primers *C_H_rew* and *V_LB_{rew}* are used. The clone with correct insert should have 1.7-kb band.
- Purify plasmid DNA according to the manufacturer's instruction. Measure the DNA concentration by Nano-drop.

6. Sequence to confirm by using the following primers:
 - (a) IRES_seqFow: 5' CACAGGCGTGCCTCTAAGG 3' for IgG1 constant domain.
 - (b) C_H1_seqFow: 5' ACCAAGGGCCCATCGGTCTT 3' for IgG1 constant domain.
 - (c) C_H3_seqFow: 5' TATCCCAGCGACATCGCCGT 3' for appended scFvB.
 - (d) pBh1f_seqRew: 5' AGATGGCTGGCAACTAGAAG 3' for appended scFvB.

3.5 Expression and Purification of the IgG-scFv BsAb in Free Style 293 Cells

3.5.1 Purification of Plasmid DNA (Large Scale)

Invitrogen PureLink™ HiPure Plasmid DNA purification kit is used in this experiment. Other kits can be also used for this purpose. To ensure to have enough DNA for the transient expression experiment, purification of DNA from 250 ml of LBA overnight culture is recommended.

1. Inoculate an individual *E. coli* clone with the right insert from the master plate into 5 ml of LBA in a 14-ml sterile snap on tube. Incubate at 37 °C overnight.
2. Inoculate the overnight culture into 250 ml of LBA in 1–100 ratios. Incubate at 37 °C overnight.
3. Harvest the cells and purify the DNA by using the Pure-Link™ HiPure Plasmid DNA purification kit following the manufacturer's instructions. Wash the purified DNA pellet with 1 ml of 75 % of ethanol twice (*see Note 20*).
4. Air-dry the DNA. Resuspend the DNA in 0.5–1 ml of sterile water (*see Note 21*).
5. Measure the concentration of DNA.

3.5.2 Expression of the IgG-scFv BsAb in 293 Free Style Cells (See Note 22)

The experiment is designed for a 120 ml-scale expression. Calculate the correct volume of reagents according to manufacturer's instruction and use the suitable-size flask for different scale of transfection.

1. Approximately 24 h before transfection, pass FreeStyle™ 293-F cells at $2.5\text{--}3.0 \times 10^6$ cells/ml. Place the flask on an orbital shaker platform rotating at 135 rpm at 37 °C, 8 % CO₂.
2. On the day of transfection, transfer a small aliquot of the cell suspension to a microcentrifuge tube and determine viability and the amount of cell clumping using the trypan blue dye exclusion method. Vigorously vortex for 45 s to breakup cell clumps and determine total cell counts using a Coulter Counter or a hemacytometer. Viability of cells must be over 90 %.
3. Dilute the cells to 1×10^6 /ml with FreeStyle™ 293 Expression Medium. Transfer 120 ml of cells to a 500 ml-shaker flask.

Place the shaker flask back to the 37 °C incubator on an orbital shaker.

4. Gently invert the tube of FreeStyle™ MAX Transfection Reagent several times to mix. Do not vortex.
5. For each transfection sample, prepare lipid–DNA complexes by performing the following:
 - A: Dilute 150 µg of plasmid DNA to OptiPro™ SFM to a total volume of 2.4 ml. Mix gently.
 - B: Dilute 150 µl of FreeStyle™ MAX Reagent to a total volume of 2.4 ml. Mix gently.
6. Mix A and B immediately by inverting the tube for a few times.
7. Incubate the lipid mixture for 10 min at room temperature to allow the DNA–293fectin™ complexes to form (no longer than 20 min).
8. Slowly add the DNA–lipid mixture into the 500 ml flask containing cells while slowly swirling the flask.
9. Incubate transfected cell cultures at 37 °C, 8 % CO₂ on an orbital shaker platform rotating at 135 rpm.
10. Harvest the supernatant between 5 and 7 days (*see Note 23*).

3.5.3 Purification of the IgG-scFv BsAb by Protein A Affinity Chromatography

1. Estimate the antibody expression level by using ELISA or other methods. Pick a suitable-size Hitrap™ rProtein A FF column (1 ml) based on the antibody expression level (*see Note 24*).
2. Connect the column to a pump. Equilibrate the column with PBS.
3. Load through a pump the filtered sample to the protein A column at a speed of 1.0 ml/min.
4. Wash the column with PBS at 25× the column volume.
5. Elute the antibody with 10× the column volume of elution buffer, Tri-Glycine (pH 2.9), or citric acid (pH 3.0) (*see Note 25*).
6. Collect 10× 1.0 ml fractions. Each collection tube contains 100 µl Tris–HCl buffer (pH 8.0) to bring the pH of the eluted material back to 7.0.
7. Re-equilibrate the column with PBS to prepare for the next run.
8. Measure OD280 of each fraction for a rough estimation of the protein concentration.
9. Pool all eluted fractions with antibodies. Dialyze the purified antibody overnight against PBS.
10. Concentrate the samples if desired. Determine the protein concentration by measuring OD280. Aliquot the final antibody preparations and store at –80 °C for future use.

3.5.4 SDS-PAGE Analysis
of the Purified
IgG-scFv BsAb

1. Sample Preparation

For nonreducing conditions: Mix 5 µg of purified antibodies with 15 µl 4× NuPAGE®LDS Sample buffer in a 1.5-ml Eppendorf tube. Add PBS to the final volume of 60 µl.

For reducing conditions: Mix 5 µg of purified antibodies with 15 µl 4× NuPAGE®LDS Sample buffer and 6 µl of NuPAGE®Sample reducing agent in a 1.5-ml Eppendorf tube. Add PBS to the final volume of 60 µl. Heat the sample tubes at 100 °C for 10 min.

2. Gel Electrophoresis

Load both the reduced and nonreduced samples, along with a molecular weight standard (see Blue®Plus2 Pre-Stained Standard), onto each well of a 4–12 % NuPAGE® Novex Bis-Tris Gel (10 well, 1.5 mm thick). Run the gel at 200 V constant voltage for about 50 min. The start current is about 110–125 mA, the end current is about 70–80 mA.

Remove the gel from cassette, wash the gel 3× with deionized water at RT for 10 min each, following by incubation of the gel with 100 ml staining buffer at RT for 1 h.

Destain the gel with deionized water at RT for 1–2 h. Take a picture of the gel (Fig. 3).

3.6 Binding
Activities of the
IgG-scFv BsAb to Its
Targets (by ELISA)

3.6.1 Target Cross-
Linking
(Dual-Binding) Assay

1. Coating Target 1 onto the ELISA Plate

Add 100 µl of target 1 (1–2 µg/ml) to each well of a flat bottom 96-well ELISA plate. Incubate the plate at 4 °C overnight.

Wash the plate with PBST two times. Add 200 µl of 3 % PBSM to each well and incubate the plate at RT for 2 h (or at 37 °C for 1 h).

Wash the plate with PBST two times.

2. Preparation of the IgG-scFv BsAb–Target 2 Complex

Prepare 200 µl of the IgG-scFv BsAb and control mono-specific antibodies A (AbA) and B (AbB), both in IgG format, in PBSM at concentration of 10 nM.

Block a 96-well round-bottom plate with 3 % PBSM for 2 h at RT (or 1 h in 37 °C).

Aliquot 50 µl of each antibody preparation to each well of the blocked 96-well round-bottom plate in triplicate.

Add 50 µl of a biotin-labeled target 2 (see Note 26) in PBS (2 µg/ml) to each well of the plate containing the antibody preparation.

Rock the plate on a slow shaker at RT for 1 h.

3. Target Crossing-Linking Assay

Transfer the antibody–target 2 mixture to the plate pre-coated with target 1.

Incubate the plate at RT for 1 h.

Wash the plate with PBST three times.

Add 100 μ l of streptavidin–HRP (1 μ g/ml) to each well of the plate. Incubate the plate at RT for an additional hour.

Wash the plate five times with PBST.

Add 100 μ l of substrate mixture (1:1 dilution of substrate A and B from TMB) to each well. Leave the plate at RT until sufficient blue color develops.

Add 100 μ l of 1 N H_2SO_4 to each well to stop the reaction. The color turns from blue to yellow.

Read the absorbance at 450 nm using an ELISA plate reader.

Calculate the mean and standard deviation of the triplicates and plot the bar graph by using Graphpad from Prism (Fig. 4a).

3.6.2 Dose-Dependent Binding of the IgG-scFv BsAb to Its Targets

1. Coating and Blocking of ELISA Plates

Coat ELISA plates with either target 1 or target 2 as described in “Coating Target 1 onto the ELISA Plate”.

2. Preparation of Antibody Dilutions

Fill each well of a 96-well plate from row 2 to row 8 with 220 μ l of PBS (in triplicates).

Add 330 μ l of antibodies in a concentration 50 nM to the wells of row 1 of the 96-well plate (in triplicates).

Transfer 110 μ l antibodies from wells in row 1 to those in row 2, mix well the solution by pipetting up and down for at least ten times (1–3 dilution).

Transfer 110 μ l of antibodies solution from wells in row 2 to those in row 3, mix, and repeat the dilution procedure until row 8.

3. ELISA

Transfer the diluted antibody samples to the receptor-coated 96-well plates. Incubate the plate at RT for 1 h.

Wash plate with PBST three times. Add 100 μ l of a goat antihuman IgG-Fab-specific antibody–HRP conjugate (1/5,000 diluted in 3 % PBSM) per well and incubate the plate for an additional 1 h at RT.

Wash plates, develop color, and read OD450nm as described in “Target Crossing-Linking Assay”.

Use GraphPad from Prism to plot a graph of OD450 vs. antibody concentration (Fig. 4b, c).

4 Notes

1. In addition to the IgG-scFv format described in this protocol, scFv can also be fused to the C-terminal of an IgG light chain [28, 29], or the N-terminal of an IgG heavy chain [29] to generate IgG-like bispecific antibodies. Further, two scFvs directed against different antigens or epitopes can be fused simultaneously to both the C-terminal and the N-terminal of an IgG heavy chain to generate a trispecific antibody [29]. According to ref. [28], fusion of an scFv or even a smaller peptide to the C-terminus of an IgG light chain appeared to disrupt the disulfide bond formation between the light and heavy chains, but did not seem to affect the binding, stability, or in vivo properties of the resulting BsAb.
2. A flexible peptide, usually in the form of $[(\text{Gly})_4\text{Ser}]_n$ ($n=0-4$), is often used as the linker between the scFv and its IgG fusion partner, when constructing the BsAb in both C-terminal and N-terminal fusion formats. The optimal linker length may vary, between 0 and 20 amino acids, among different IgG-scFv fusion partners, thus needs to be experimentally tested.
3. There are a variety of methods for purification of DNA from *E. coli*. It is recommended to choose the protocols most convenient and comfortable to the investigator. DNA concentration is measured by NanoDrop photometer due to the lower amount usage.
4. Proofreading DNA-polymerase such as *pfx* can be used to amplify the gene to reduce PCR error. But PCR yield is much lower in some cases.
5. The following procedures can be used to increase the yield of PCR:
 - (a) Optimize the PCR conditions including using different concentration of MgSO₄, template, and primers; changing the annealing temperature; using purified primers.
 - (b) Synthesize new PCR primers with different T_m.
 - (c) Precipitate the PCR reaction mixture by ethanol and use the recovered products as templates to re-amplify the VH and VL genes.
 - (d) Try different brand DNA polymerases.
6. During the primary PCR reaction to amplify the VH and VL products, additional bands may be produced. This should not cause any problems when the VH and VL bands (350 bp) are excised and purified from the gel for further steps.

7. There are a variety of methods for purification of DNA from agarose gel. It is recommended to choose the protocols most convenient and comfortable to the investigator.
8. scFv assembling efficiency highly depends on the quality and quantity of VH and VL fragments. Therefore, VH and VL need to be purified and their concentrations need to be measured by Nano-drop first. Alternatively, DNA fragments are analyzed in 1.5 % agarose gel to ensure that same amount of VH and VL is used for assembling.
9. If the yield of the scFv product is poor after the assembly and amplification process, it is recommended:
 - (a) Precipitate the PCR reaction mixture by ethanol and use the recovered products as templates to re-amplify the scFv genes.
 - (b) Adjust the amount of VH and VL in the assembling reaction. There could be significant deviation in the quantification of VH and VL products especially when the PCR yields are low.
 - (c) Change the overlapping length between 3' VH primer and 5' VL primer.
10. There are a variety of PCR cloning kits available. It is recommended to choose the kit and protocols most convenient and comfortable to the investigator.
11. If there are more than one PCR products appearing after assembling, it is recommended to excise and purify the 750-bp band after gel electrophoresis. To the purified fragment, add Taq polymerase buffer, dATP, and 0.5 unit of Taq polymerase, incubate the reaction for 10–15 min at 72 °C, and use the mixture in the pCR®2.1-TOPO® cloning reaction.
12. If proofreading polymerases are used in the PCR reaction, addition of 3' A-overhangs is recommended. After PCR amplification, place vials on ice and add 0.7 unit of Taq polymerase, mix and incubate at 72 °C for 8–10 min. Place the reaction mixture on ice and use immediately in the pCR®2.1-TOPO® cloning reaction.
13. The following conditions may affect the cloning efficiency:
 - (a) pH > 9: Check the pH of the PCR reaction and adjust with 1 M Tris-HCl to pH = 8.
 - (b) Excess (or overly dilute) PCR product: Reduce (or concentrate) the PCR product.
 - (c) PCR products do not contain sufficient 3' A-overhangs even though Taq polymerase is used: Taq polymerase is less efficient at adding a nontemplate 3' A next to another A. Taq is most efficient at adding a nontemplate 3' A next

- to a C. Redesign the primers so that they contain a 5' G instead of a 5' T.
14. The scFv fragments could be cloned into the vector in two different orientations. It will not affect the subsequent experiments as long as the DNA sequence of the scFv inserts is correct
 15. HFTM enzymes are available from NEB. In this case, buffer IV can be used for double digestion.
 16. There are a few methods to reduce the cloning background from the uncompleted vector digestion and vector self-ligation:
 - (a) Sequential digestion instead of double digestion.
 - (b) Dephosphorylation of vector by using alkaline phosphatase, such as CIP.
 17. For the best efficiency of DNA ligation, a molar ratio of insert to vector is about 3–5 to 1. Several ligation reactions with various insert/vector molar ratios can be set up to optimize the ligation.
 18. There are a variety of bacterial host cells and methods for transformation of plasmid DNA. It is recommended to choose the protocols most convenient and comfortable to the investigator.
 19. There is a *BclI* site on the light chain constant domain of λ subtype antibody. If the conventional IgG part is λ subtype, the *BclI* site needs to be removed by silent mutagenesis. Alternatively, the noncommon antibody digestion site such as *NotI* and *BsiWI* can be added to the c-terminal of CH3 in expression vector pBh1. The QuikChange XL Site-Directed Mutagenesis Kit from Agilent is recommended for this purpose.
 20. Plasmid DNA for transfection into eukaryotic cells must be clean, sterile, and free from phenol and sodium chloride. Contaminants may kill the cells, and salt will interfere with complex formation, decreasing transfection efficiency. It is recommended to wash the DNA with 70 % of ethanol. DNA preparation is further decontaminated by performing filtration through a 0.22 μm filter before use. After this step, all experiments should be performed under sterile conditions to avoid potential contamination during mammalian cell expression.
 21. The plasmid DNA is diluted with certain ratio of the transfection reagent. Therefore, DNA concentration is very important. It is recommended to dissolve the DNA in small amount of MQ H₂O and measuring the concentration first. If the concentration is too high, more water can be added to make sure

that DNA is completely dissolved. It is ideal to have the final DNA concentration between 1 and 2 mg/ml.

22. Other cell lines, such as 293 and CHO, are also being commonly used as the host cells for transient expression of antibody molecules. It is recommended to choose cell lines and transfection protocols most convenient and comfortable to the investigator.
23. To enhance antibody production in transient transfection, it is suggested:
 - (a) Make sure that cell viability is greater than 90 %, and in 3–30 passages.
 - (b) Optimize transfection conditions by varying DNA and transfection reagent ratio.
 - (c) Test the antibody concentration at different time points after transfection to determine the optimal time point for culture harvesting.
24. It is recommended to concentrate the supernatant before Protein A purification if the antibody concentration is too low. As an alternative to column chromatography, batch purification method can also be used for concentrated supernatant of small volume. In a 50-ml Falcon tube, mix 40 ml of supernatant with 0.5 ml of PBS-washed Protein A sepharose beads and incubate at RT for 1 h (or 4 °C for 2 h). Centrifuge down the beads and aspirate the supernatant. Pack the beads to a 10-ml column. Wash the column with 15-ml PBS and elute the IgG-scFv as described in Subheading 3.5.3.
25. Certain antibodies may precipitate in Tri-glycine elution buffer. In this case, it is recommended to use citric acid buffer (pH=3) to elute the protein.
26. Protein is labeled with biotin according to the manufacture's instruction. It is recommended to test the biotin-labeled protein for binding activity before its use in the cross-linking ELISA.

References

1. Fischer N, Leger O (2007) Bispecific antibodies: molecules that enable novel therapeutic strategies. *Pathobiology* 74:3–14
2. Jain M, Kamal N, Batra SK (2007) Engineering antibodies for clinical applications. *Trends Biotechnol* 25:307–316
3. Demarest SJ, Glaser SM (2008) Antibody therapeutics, anti-body engineering, and the merits of protein stability. *Curr Opin Drug Discov Devel* 11:675–687
4. Chames P, Baty D (2009) Bispecific antibodies for cancer therapy. *Curr Opin Drug Discov Devel* 12:276–283
5. Thakur A, Lum LG (2010) Cancer therapy with bispecific antibodies: clinical experience. *Curr Opin Mol Ther* 12:340–349
6. Kipriyanov SM, Le Gall F (2004) Recent advances in the generation of bispecific antibodies for tumor immunotherapy. *Curr Opin Drug Discov Devel* 7:233–242
7. Lum LG, Thakur A (2011) Targeting T cells with bispecific antibodies for cancer therapy. *BioDrugs* 25:365–379
8. Shen J, Zhu Z (2008) Catumaxomab, a rat/murine hybrid trifunctional bispecific mono-

- clonal antibody for the treatment of cancer. *Curr Opin Mol Ther* 10:373–384
9. Marvin JS, Zhu Z (2006) Bispecific antibodies for dual-modality cancer therapy: killing two signaling cascades with one stone. *Curr Opin Drug Discov Devel* 9:184–193
 10. Lu D, Zhang H, Koo H et al (2005) A fully human recombinant IgG-like bispecific antibody to both the epidermal growth factor receptor and the insulin-like growth factor receptor for enhanced antitumor activity. *J Biol Chem* 280:19665–19672
 11. Wu C, Ying H, Grinnell C et al (2007) Simultaneous targeting of multiple disease mediators by a dual-variable-domain immunoglobulin. *Nat Biotechnol* 25:1290–1297
 12. Schaeter G, Haber L, Crocker L et al (2011) A two-in-one antibody against HER3 and EGFR has superior inhibitory activity compared with monospecific antibodies. *Cancer Cell* 20:472–486
 13. Michaelson JS, Demarest SJ, Miller B et al (2009) Anti-tumor activity of stability-engineered IgG-like bispecific antibodies targeting TRAIL-R2 and LTbetaR. *MAbs* 1:128–141
 14. Dong J, Sereno A, Aivazian D et al (2011) A stable IgG-like bispecific antibody targeting the epidermal growth factor receptor and the type I insulin-like growth factor receptor demonstrates superior anti-tumor activity. *MAbs* 3:273–288
 15. Baeuerle P (2012) Revival of bispecific antibodies, resource of 3rd annual world bispecific antibody summit (Boston, USA). <http://bispecific.com/uploads/ffiles/2012/05/904821.pdf>
 16. Marvin JS, Zhu Z (2005) Recombinant approaches to IgG-like bispecific antibodies. *Acta Pharmacol Sin* 26:649–658
 17. Dong J, Sereno A, Snyder WB et al (2011) Stable IgG-like bispecific antibodies directed towards the type I insulin-like growth factor receptor demonstrate enhanced ligand blockade and anti-tumor activity. *J Biol Chem* 286:4703–4717
 18. de Haard HJ, van Neer N, Reurs A et al (1999) A large non-immunized human Fab fragment phage library that permits rapid isolation and kinetic analysis of high affinity antibodies. *J Biol Chem* 274:18218–18230
 19. Hoet RM, Cohen EH, Kent RB et al (2005) Generation of high-affinity human antibodies by combing donor-derived and synthetic complementarity-determining-region diversity. *Nat Biotechnol* 23:344–348
 20. Lu D, Shen J, Vil MD et al (2003) Tailoring in vitro selection for a picomolar affinity human antibody directed against vascular endothelial growth factor receptor 2 for enhanced neutralizing activity. *J Biol Chem* 278:43496–43507
 21. Reiter Y, Brinkmann U, Lee B et al (1996) Engineering antibody Fv fragments for cancer detection and therapy: disulfide-stabilized Fv fragments. *Nat Biotechnol* 14:1239–1245
 22. Worn A, Pluckthun A (2001) Stability engineering of scfv fragments. *J Mol Biol* 305:989–1010
 23. Miller BR, Demarest SJ, Lugovskoy A et al (2010) Stability engineering of scFvs for the development of bispecific and multivalent antibodies. *Protein Eng Des Sel* 23:549–557
 24. Demarest SJ, Glaser SM (2008) Antibody therapeutics, antibody engineering, and the merits of protein stability. *Curr Opin Drug Discov Devel* 11:675–687
 25. Mabry R, Lewis KE, Moore M et al (2010) Engineering of stable bispecific antibodies targeting IL-17A and IL-23. *Protein Eng Des Sel* 23:115–127
 26. Mabry R, Snively M (2010) Therapeutic bispecific antibodies: the selection of stable single-chain fragments to overcome engineering obstacles. *IDrugs* 13:543–549
 27. Lu D, Jimenez X, Witte L, Zhu Z (2004) The effect of variable domain orientation and arrangement on the antigen-binding activity of a recombinant human bispecific diabody. *Biochem Biophys Res Commun* 28:507–513
 28. Orcutt KD, Ackerman ME, Cieslewicz M et al (2009) A modular IgG-scFv bispecific antibody topology. *Protein Eng Des Sel* 23:221–228
 29. Dimasi N, Gao C, Fleming R et al (2009) The design and characterization of oligospecific antibodies for simultaneous targeting of multiple disease mediators. *J Mol Biol* 393:672–692

Construction of Human Antibody Gene Libraries and Selection of Antibodies by Phage Display

André Frenzel, Jonas Kügler, Sonja Wilke,
Thomas Schirrmann, and Michael Hust

Abstract

Antibody phage display is the most commonly used in vitro selection technology and has yielded thousands of useful antibodies for research, diagnostics, and therapy.

The prerequisite for successful generation and development of human recombinant antibodies using phage display is the construction of a high-quality antibody gene library. Here, we describe the methods for the construction of human immune and naive scFv gene libraries.

The success also depends on the panning strategy for the selection of binders from these libraries. In this article, we describe a panning strategy that is high-throughput compatible and allows parallel selection in microtiter plates.

Key words Antibody, Phage display, scFv, Library, Naive library, Immune library, In vitro selection, Panning

1 Introduction

Generation of recombinant antibodies is an essential process in the development of valuable tools for research and diagnostic, and for therapeutic antibodies.

One important field for antibodies in research is providing binders to analyze the whole proteome. After sequencing of the human genome, including the genome of individual persons, research focus shifted to the analysis of gene products. The human genome encodes about 20,000–25,000 protein encoding genes [1, 2]. Due to alternative mRNA splicing and posttranslational modifications, the number of different human proteins is supposed to exceed the amount of genes several fold [3]. For each gene tools are necessary to investigate amount, localization, and function of its products. Here, antibodies represent a key tool for the decryption of the human proteome. Only in vitro technologies like phage display are assumed to deliver these binders [4–9]. For this purpose,

pilot projects to generate antibodies to the complete human genome were performed and complete antibody generation pipelines have been developed [10–12].

To date, there are many examples for the application of antibodies derived by phage display for diagnostics [13–15]. A great advantage of antibody phage display for diagnostic is the direct access to the genetic information of the binder, allowing for a fast adaptation of the antibody format (e.g. IgG, scFv-Fc, biotinylated antibody, or scFv-phoA fusion [10] to the desired diagnostic assay).

Until January 2012, 32 therapeutic monoclonal antibodies are approved by the US Food and Drug Administration (FDA) or European Medicines Agency (EMA, since 2009 EMA) with additional candidates pending approval (<http://www.landesbioscience.com/journals/mabs/about>). The primary applications of therapeutic antibodies are cancer and autoimmune diseases [16]. The mechanisms of therapeutic antibodies are diverse and include neutralizing of substances, e.g. toxins [17–19] or cytokines [20], blocking of receptors [21], binding to cells and activating the host-immune system [22], or combinations of these effects [23]. In 1986, the first antibody of murine origin muronomab-CD3 (Orthoclone OKT3®) was approved for therapy [22]. The second generation of therapeutic antibodies were chimeric, e.g. Infliximab (Remicade®) [24] or Cetuximab (Erbix®) [25], and later the antibodies were humanized, e.g. Trastuzumab [26]. In 2002, the first fully-human antibody was commercially available. Adalimumab (Humira®) was isolated using antibody phage display by guided selection [27]. Human antibodies are assumed to be less immunogenic, but also these fully human molecules can lead to adverse events [28, 29].

Currently, two major strategies are used for the generation of human antibodies: transgenic mice and in vitro selection technologies. Transgenic mice contain the human immunoglobulin repertoire instead of the murine, allowing the generation of human antibodies by the hybridoma technology [30–33]. An advantage of transgenic mice is the in vivo affinity maturation. Already, transgenic mice yielded a significant number of antibodies which reached clinical studies. Examples are Panitumumab (Vectibix®) and Golimumab (Simponi®) [34, 35]. The disadvantages are limitations in respect of toxic and conserved antigens [36].

The alternative is the generation of human antibodies by antibody phage display which is completely independent from any immune system by an in vitro selection process, called “panning.” The first antibody gene repertoires in phage were generated and screened by using the lytic phage Lambda [37], however, with limited success. The display method most commonly used today is based on the groundbreaking work of Georg P. Smith on filamentous phage display [38]. Here, genotype and phenotype of oligopeptides were linked by fusing the corresponding gene

fragments to the minor coat protein III gene of the filamentous bacteriophage M13. The resulting peptide::pIII fusion protein is expressed on the surface of phage allowing the affinity purification of the peptide and its corresponding gene. In the same way, antibody fragments fused to pIII can be presented on the surface of M13 phage particles. This technology was invented in parallel in Cambridge, Heidelberg, and La Jolla in 1990/1991 [39–44]. Due to the limitations of the *E. coli* folding machinery, only antibody fragments like scFv (single-chain Fragment variable), Fab (Fragment antigen binding), VHH (camel heavy chain variable domain), or dAbs (human heavy chain variable domain) are used routinely for antibody phage display [45–47], as the production of IgGs in *E. coli* is possible only in rare cases [48, 49]. Two different genetic systems have been developed for the expression of the antibody::pIII fusion proteins for phage display. First, the antibody genes can be directly inserted into the phage genome fused to the wild-type pIII gene [44]. However, most of the successful systems, uncouple antibody expression from phage propagation by providing the genes encoding the antibody::pIII fusion proteins on a separate plasmid (called “phagemid”) and containing a phage morphogenetic signal for packaging the vector into the assembled phage particles [40]. Despite other *in vitro* methods like ribosomal display [50, 51], puromycin display [52], or yeast surface display [53], antibody phage display has become the most widely used selection method for human antibodies. To date, several therapeutic antibodies derived from phage display are in clinical development [16, 54–57].

2 Materials

2.1 Construction of Antibody Gene Libraries

2.1.1 Isolation of Lymphocytes

1. Phosphate buffered saline (PBS) pH 7.4 (8.0 g NaCl, 0.2 g KCl, 1.44 g Na₂HPO₄·2H₂O, 0.24 g KH₂PO₄ in 1 L).
2. Lymphoprep (Progen, Heidelberg).
3. mRNA isolation Kit (Oligotex mRNA Minikit, Qiagen, Hilden, Germany) or Trizol (Invitrogen, Karlsruhe, Germany) for total RNA.

2.1.2 cDNA Synthesis

1. Superscript III (Invitrogen) + 5× RT buffer + 0.1 m DTT.
2. RNaseOut (Invitrogen).
3. Random hexamer oligonucleotide primer (dN₆).
4. dNTP mix (10 mM each).

2.1.3 First and Second Antibody Gene PCR

1. GoTaq (Promega, Mannheim, Germany) + 5× buffer.
2. dNTP mix (10 mM each).
3. Oligonucleotide primer (*see* Table 1).

Table 1
Primers used for first and second PCR of antibody genes for antibody gene library construction using phagemids like pHAL14 or pHAL30. Restriction sites are *underlined*

Primer	5' to 3' sequence
First antibody gene PCR VH	
MHVH1_f	cag gtb cag ctg gtg cag tct gg
MHVH1/7_f	car rts cag ctg gtr car tct gg
MHVH2_f	cag rtc acc ttg aag gag tct gg
MHVH3_f1	sar gtg cag ctg gtg gag tct gg
MHVH3_f2	gag gtg cag ctg ktg gag wcy sg
MHVH4_f1	cag gtg car ctg cag gag tct gg
MHVH4_f2	cag stg cag ctr cag sag tss gg
MHVH5_f	gar gtg cag ctg gtg cag tct gg
MHVH6_f	cag gta cag ctg cag cag tca gg
MHIgMCH1_r	aag ggt tgg ggc gga tgc act
MHIgGCH1_r	gac cga tgg gcc ctt ggt gga
MHIgECH1_r	tgg gct ctg tgt gga gg
First antibody gene PCR kappa	
MHVK1_f1	gac atc cag atg acc cag tct cc
MHVK1_f2	gmc atc crg wtg acc cag tct cc
MHVK2_f	gat rtt gtg atg acy cag wct cc
MHVK3_f	gaa atw gtg wtg acr cag tct cc
MHVK4_f	gac atc gtg atg acc cag tct cc
MHVK5_f	gaa acg aca ctc acg cag tct cc
MHVK6_f	gaw rtt gtg mtg acw cag tct cc
MHkappaCL_r	aca ctc tcc cct gtt gaa gct ctt
First antibody gene PCR lambda	
MHVL1_f1	cag tct gtg ctg act cag cca cc
MHVL1_f2	cag tct gtg ytg acg cag ccg cc
MHVL2_f	cag tct gcc ctg act cag cct
MHVL3_f1	tcc tat gwg ctg acw cag cca cc
MHVL3_f2	tct tct gag ctg act cag gac cc
MHVL4_f1	ctg cct gtg ctg act cag ccc
MHVL4_f2	cag cyt gtg ctg act caa tcr yc
MHVL5_f	cag sct gtg ctg act cag cc
MHVL6_f	aat ttt atg ctg act cag ccc ca
MHVL7/8_f	cag rct gtg gtg acy cag gag cc
MHVL9/10_f	cag scw gkg ctg act cag cca cc
MHlambdaCL_r	tga aca ttc tgt agg ggc cac tg
MHlambdaCL_r2	tga aca ttc cgt agg ggc aac tg

(continued)

Table 1
(continued)

Primer	5' to 3' sequence
Second antibody gene PCR VH	
MHVH1-NcoI_f	gtcctcgca cc atg gcc cag gtb cag ctg gtg cag tct gg
MHVH1/7-NcoI_f	gtcctcgca <u>cc atg gcc</u> car rts cag ctg gtr car tct gg
MHVH2-NcoI_f	gtcctcgca <u>cc atg gcc</u> cag rtc acc ttg aag gag tct gg
MHVH3-NcoI_f1	gtcctcgca <u>cc atg gcc</u> sar gtg cag ctg gtg gag tct gg
MHVH3-NcoI_f2	gtcctcgca <u>cc atg gcc</u> gag gtg cag ctg ktg gag wcy sg
MHVH4-NcoI_f1	gtcctcgca <u>cc atg gcc</u> cag gtg car ctg cag gag tcg gg
MHVH4-NcoI_f2	gtcctcgca <u>cc atg gcc</u> cag stg cag ctr cag sag tss gg
MHVH5-NcoI_f	gtcctcgca <u>cc atg gcc</u> gar gtg cag ctg gtg cag tct gg
MHVH6-NcoI_f	gtcctcgca <u>cc atg gcc</u> cag gta cag ctg cag cag tca gg
MHIgMCH1scFv-HindIII_r	gtcctcgca <u>aag ctt</u> tgg ggc gga tgc act
MHIgGCH1scFv-HindIII_r	gtcctcgca <u>aag ctt</u> gac cga tgg gcc ctt ggt gga
MHIgECH1scFv-HindIII_r	gtcctcgca <u>aag ctt</u> tgg gct ctg tgt gga gg
Second antibody gene PCR kappa	
MHVK1-MluI_f1	accgcctcc <u>a cgc gta</u> gac atc cag atg acc cag tct cc
MHVK1-MluI_f2	accgcctcc <u>a cgc gta</u> gmc atc crg wtg acc cag tct cc
MHVK2-MluI_f	accgcctcc <u>a cgc gta</u> gat rtt gtg atg acy cag wct cc
MHVK3-MluI_f	accgcctcc <u>a cgc gta</u> gaa atw gtg wtg acr cag tct cc
MHVK4-MluI_f	accgcctcc <u>a cgc gta</u> gac atc gtg atg acc cag tct cc
MHVK5-MluI_f	accgcctcc <u>a cgc gta</u> gaa acg aca ctc acg cag tct cc
MHVK6-MluI_f	accgcctcc <u>a cgc gta</u> gaw rtt gtg mtg acw cag tct cc
MHkappaCLscFv-NotI_r	accgcctcc <u>gc gcc cgc</u> gaa gac aga tgg tgc agc cac agt
Second antibody gene PCR lambda	
MHVL1-MluI_f1	accgcctcc <u>a cgc gta</u> cag tct gtg ctg act cag cca cc
MHVL1-MluI_f2	accgcctcc <u>a cgc gta</u> cag tct gtg ytg acg cag ccg cc
MHVL2-MluI_f	accgcctcc <u>a cgc gta</u> cag tct gcc ctg act cag cct
MHVL3-MluI_f1	accgcctcc <u>a cgc gta</u> tcc tat gwg ctg acw cag cca cc
MHVL3-MluI_f2	accgcctcc <u>a cgc gta</u> tct tct gag ctg act cag gac cc
MHVL4-MluI_f1	accgcctcc <u>a cgc gta</u> ctg cct gtg ctg act cag ccc
MHVL4-MluI_f2	accgcctcc <u>a cgc gta</u> cag cyt gtg ctg act caa tcr yc
MHVL5-MluI_f	accgcctcc <u>a cgc gta</u> cag sct gtg ctg act cag cc
MHVL6-MluI_f	accgcctcc <u>a cgc gta</u> aat ttt atg ctg act cag ccc ca
MHVL7/8-MluI_f	accgcctcc <u>a cgc gta</u> cag rct gtg gtg acy cag gag cc
MHVL9/10-MluI_f	accgcctcc <u>a cgc gta</u> cag scw gkg ctg act cag cca cc
MHLambdaCLscFv-NotI_r	accgcctcc <u>gc gcc cgc</u> aga gga sgg ygg gaa cag agt gac
Primer for colony PCR and sequencing	
MHLacZ-Pro_f	ggctcgtatggtgtgtgg
MHgIII_r	c taa agt ttt gtc gtc ttt cc

4. Agarose (Peqlab, Erlangen, Germany).
5. TAE-buffer 50× (2 M Tris-HCl, 1 M acetic acid, 0.05 M EDTA pH 8).
6. NucleoSpin Gel and PCR Clean-up (Macherey-Nagel, Düren, Germany).

2.1.4 First Cloning

Step: VI

1. MluI (NEB, Frankfurt, Germany).
2. NotI (NEB).
3. NEBuffer 3 (NEB).
4. BSA (NEB).
5. Calf intestine phosphatase (CIP) (MBI Fermentas, St. Leon-Rot).
6. T4 ligase (Promega, Mannheim).
7. 3 M sodium acetate pH 5.2.
8. *E. coli* XL1-Blue MRF' (Agilent, Böblingen, Germany), genotype: $\Delta(mcrA)183 \Delta(mcrCB-bsdSMR-mrr)173 endA1 supE44 thi-1 recA1 gyrA96 relA1 lac$ [F' *proAB lacI^qZ*ΔM15 Tn10 (Tet^r)].
9. Electroporator MicroPulser (BIO-RAD, München).
10. 2 M Glucose (steril filtered).
11. 2 M Magnesium solution (1 M MgCl₂, 1 M MgSO₄) (autoclaved).
12. SOC medium pH 7.0 (2 % (w/v) tryptone, 0.5 % (w/v) yeast extract, 0.05 % (w/v) NaCl, 20 mM Mg solution, 20 mM glucose) (sterilize magnesium and glucose separately, add solutions after autoclavation).
13. 2×TY-medium pH 7,0 (1,6 % (w/v) tryptone, 1 % (w/v) yeast extract, 0,5 % (w/v) NaCl).
14. Ampicillin (100 mg/mL stock).
15. 2×TY-GAT (2×TY+100 mM glucose+100 μg/mL ampicillin+20 μg/mL tetracycline).
16. Tetracycline (10 mg/mL stock).
17. 9 cm Petri dishes.
18. 25 cm square Petri dishes (“pizza plates”).
19. 2×TY-GAT agar plates (2×TY-GAT, 1.5 % (w/v) agar-agar).
20. Nucleobond Extra Midi Kit (Macherey-Nagel).

2.1.5 Second Cloning

Step: VII

1. NcoI-HF (NEB).
2. HindIII-HF (NEB).
3. NEBuffer 4 (NEB).
4. Glycerol of 99.5 % (Roth, Karlsruhe, Germany).

2.1.6 Colony PCR

1. Oligonucleotide primer (*see* Table 1).

2.1.7 Library Packaging and scFv Phage Production

1. 2×TY-GA medium (2×TY, 100 mM glucose, 100 µg/mL ampicillin).
2. M13K07 Helperphage (Stratagene) for monovalent display.
3. Hyperphage for oligovalent display (Progen, Heidelberg).
4. 2×TY-AK (2×TY, containing 100 µg/mL ampicillin, 50 µg/mL kanamycin).
5. Sorval Centrifuge RC5B Plus, rotor GS3 and SS34.
6. Polyethylene glycol (PEG) solution (20 % (w/v) PEG 6000, 2.5 M NaCl).
7. Phage dilution buffer (10 mM Tris-HCl pH 7.5, 20 mM NaCl, 2 mM EDTA).
8. Mouse anti-pIII monoclonal antibody PSKAN3 (MoBiTec).
9. Goat anti-mouse IgG alkaline phosphatase (AP) conjugate.

2.2 Antibody Selection (Panning)

2.2.1 Coating of Microtiter Wells

1. Maxisorb microtiter plates or stripes.
2. Dimethyl sulfoxide (DMSO).
3. PBST (PBS + 0.1 % (v/v) Tween 20).

2.2.2 Panning

1. MPBST (2 % skim milk in PBST, prepare fresh).
2. Panning block solution (1 % (w/v) skim milk + 1 % (w/v) BSA in PBST, prepare fresh).
3. 10 µg/mL Trypsin in PBS.
4. *E. coli* XL1-Blue MRF' (Agilent).
5. M13K07 Helperphage (Stratagene).
6. Round bottom polypropylene microtiter plates.
7. Thermoshaker PST60-HL4.
8. Eppendorf 5810R, Rotor A-4-81 with MTP adapter.
9. 2×TY medium pH 7.0 (1.6 % (w/v) tryptone, 1 % (w/v) yeast extract, 0.5 % (w/v) NaCl).
10. 10×GA (1 M glucose, 1 mg/mL ampicillin).

2.2.3 Production of Soluble Monoclonal Antibody Fragments in Microtiter Plates

1. 96 well U-bottom polypropylene (PP) microtiter plates.
2. AeraSeal breathable sealing film (Excel Scientific, Victorville, USA).
3. Buffered 2×TY-SAI (buffered 2×TY containing 50 mM saccharose + 100 µg/mL ampicillin + 50 µM isopropyl-beta-d-thiogalactopyranoside (IPTG)).

2.2.4 ELISA of Soluble Monoclonal Antibody Fragments

1. Mouse anti-His-tag monoclonal antibody.
2. Mouse anti-myc-tag monoclonal antibody.

3. Mouse anti-pIII monoclonal antibody.
4. Goat anti-Mouse IgG serum, (Fab specific) HRP conjugated.
5. Oligonucleotide primers (*see* Table 1).

3 Methods

3.1 Construction of Single-Chain Antibody Gene Libraries

Depending on the scientific or medical applications, different types of antibody gene libraries can be constructed and used. Immune libraries are constructed from antibody V-genes isolated from IgG secreting plasma cells of immunized donors [18, 41]. Immune libraries are typically generated and used in medical research to obtain antibodies against one particular target antigen, e.g. a cell surface antigen of a pathogen or a tumor marker. Naive, semisynthetic, and synthetic libraries have been subsumed as “single-pot” libraries, as they are designed to isolate antibody fragments binding to nearly every possible antigen. Naive libraries are constructed from rearranged V genes from B cells (IgM) of nonimmunized donors. An overview of antibody gene libraries and vectors is given in various reviews [6, 58, 59].

A panel of methods have been employed to clone the genetic diversity of human antibody repertoires. After isolation of mRNA from B-lymphocytes and preparation of cDNA, the construction of immune libraries is usually done by a two step cloning or assembly PCR (*see* below). Very large “single pot” naive antibody gene libraries are generally constructed by two or three separate cloning steps. In the “two step cloning strategy,” the amplified repertoire of light chain genes is cloned first into the phage display vector. In the second step the heavy chain gene repertoire—as the heavy chain contributes more to antibody diversity, due to its highly variable CDRH3 [60]—is cloned into the phagemids containing the light chain gene repertoire [10, 61–63]. In the “three step cloning strategy,” separate heavy and light chain libraries are engineered. The VH gene repertoire has then to be excised and cloned into the phage display vector containing the repertoire of VL genes [64]. Assembly PCR is another common method used for the cloning of naive [65, 66] or immune [41] scFv phage display libraries. The VH and VL genes including the additional linker sequence are amplified separately and fused by assembly PCR, before the scFv encoding gene fragments are cloned into the vector. Since the CDRH3 is a major source of sequence variety in antibodies [60], the assembly PCR can be combined with a randomization of the CDR3 regions, leading to semisynthetic libraries. Here, oligonucleotide primers encoding various CDR3 and J gene segments were used for the amplification of the V gene segments of human germlines [67]. Hoogenboom and Winter [68] as well as Nissim and colleagues [69] used degenerated CDRH3

oligonucleotide primers to generate a semisynthetic heavy chain repertoire derived from human V gene germline segments. Afterwards, this VH repertoire was combined with an anti-BSA light chain. For some libraries a single framework of a well-known/robust antibody was used as scaffold for the integration of randomly created CDRH3 and CDRL3 [70, 71]. Jirholt and colleagues [72] and Söderlind and colleagues [73] amplified all CDR regions derived from B cells before shuffling them into this antibody framework by assembly PCR. An entirely synthetic library was described by Knappik et al. [74] who utilized seven different VH and VL germline master frameworks combined with six synthetically created CDR cassettes. The construction of large naive and semisynthetic libraries requires significant effort to tunnel the genetic diversity through the bottleneck of *E. coli* transformation, e.g. 600 transformations were necessary for the generation of a 3.5×10^{10} phage library [45].

The following protocols describe the generation of human naive or immune scFv antibody gene libraries by a two step cloning strategy already approved for naive [10] and immune libraries [17–19].

3.1.1 Isolation of Lymphocytes (Peripheral Blood Mononuclear Cells (PBMC))

1. Mix 20 mL fresh blood or EDTA/citric acid treated blood ($\sim 2 \times 10^7$ cells) of each donor with 20 mL PBS (*see Note 1*).
2. Fill 10 mL Lymphoprep in a 50 mL polypropylene tube. Carefully cover Lymphoprep with 40 mL of the diluted blood using a plastic pipette.
3. Centrifuge the blood with $800 \times g$ for 20 min at RT (without brake!).
4. The lymphocytes form a distinct layer between the Lymphoprep and the medium, whereas the erythrocytes and granulocytes will be pelleted. Carefully aspirate the lymphocytes using a plastic pipette and transfer to a new 50 mL polypropylene tube.
5. Fill up with 50 mL PBS and pellet the lymphocytes with $250 \times g$ for 10 min at RT. Discard the supernatant (be careful, the lymphocyte pellet is not solid).
6. Repeat this washing step to remove most of the thrombocytes.
7. Resuspend the lymphocytes pellet in the supplied extraction buffer of the mRNA isolation kit according to the manufacturer's instructions or use 0.5 mL Trizol for total RNA isolation (*see Note 2*). After resuspension using the mRNA extraction buffer or Trizol. The RNA pellet can be stored at -80°C .

3.1.2 *cDNA Synthesis*

1. Set up mixture for the first strand cDNA synthesis:

Solution or component	Volume	Final concentration
mRNA or total RNA	11.5 μL	50–250 ng (mRNA) or 2–20 μg (total RNA)
Random hexamer oligonucleotide primer (dN ₆) (10 μM)	2.5 μL	1.5 μM
dNTP-Mix (10 mM each)	1.25 μL	500 μM

2. Denature the RNA for 5 min at 70 °C. Afterwards directly chill down on ice for 5 min.
3. Add the following components:

Solution or component	Volume	Final concentration
RT buffer (5 \times)	5 μL	1 \times
0.1 M DTT	2.5 μL	10 mM
Superscript III reverse transcriptase (200 U/ μL)	1 μL	200 U
RNaseOut	1.25 μL	–

4. Incubate the 25 μL mixture for 5 min at 25 °C for primer annealing. Afterwards incubate 60 min at 50 °C for first strand synthesis.
5. Denature the RNA/DNA hybrids and the enzyme for 5 min at 85 °C. Store at –20 °C.

3.1.3 *First Antibody Gene PCR*

1. The cDNA derived from 50 to 250 ng mRNA or 2–20 μg total RNA will be used as template to amplify VH and the light chain. Set up the PCR reactions as follows (30 \times mastermix for 27 PCR reactions):

Solution or component	Volume	Final concentration
dH ₂ O	1,130 μL	–
Buffer with MgCl ₂ (5 \times)	300 μL	1 \times
dNTPs (10 mM each)	30 μL	200 μM each
cDNA	25 μL	Complete first strand synthesis reaction
GoTaq 5 U/ μL	7.5 μL	1.25 U

2. Divide the master mix in 450 μL for VH, 350 μL for kappa and 550 μL for lambda.
3. Add to each of the three reactions the corresponding reverse primers (*see* also Table 1) as follows (use the IgM primer for naive antibody gene libraries or the IgG primer for an immune antibody gene libraries. Also IgE libraries are possible with the IgE primer set):

Antibody gene	Primer	Volume	Final concentration
VH	MHIgMCH1_r or MHIgGCH1_r or MHIgECH1_r (10 μM)	18 μL	0.4 μM
kappa	MHkappaCL_r (10 μM)	14 μL	0.4 μM
lambda	MHlambdaCL_r1/_r2 mix (9:1) (10 μM)	22 μL	0.4 μM

4. Divide the mixture to 9 (VH), 7 (Kappa), and 11 (Lambda) PCR reactions each with 48 μL and add 2 μL (10 μM , 0.4 μM final concentration) of the subfamily-specific forward primer (*see* also Table 1):

VH:	(1) MHVH1_f, (2) MHVH1/7_f, (3) MHVH2_f, (4) MHVH3_f1, (5) MHVH3_f2, (6) MHVH4_f1, (7) MHVH4_f2, (8) MHVH5_f, (9) MHVH6_f
Vkappa:	(10) MHVK1_f1, (11) MHVK1_f2, (12) MHVK2_f, (13) MHVK3_f, (14) MHVK4_f, (15) MHVK5_f, (16) MHVK6_f
Vlambda:	(17) MHVL1_f1, (18) MHVL1_f2, (19) MHVL2_f, (20) MHVL3_f1, (21) MHVL3_f2, (22) MHVL4_f1, (23) MHVL4_f2, (24) MHVL5_f, (25) MHVL6_f, (26) MHVL7/8_f, (27) MHVL9/10_f

5. Carry out the PCR using the following program:

94 °C	1 min	
94 °C	1 min	
55 °C	1 min	
72 °C	2 min	
72 °C	10 min	

- Separate PCR products by 1.5 % TAE agarose gel electrophoresis, cut out the amplified antibody genes (VH: ~380 bp, kappa/lambda: ~650 bp) (*see Note 3*) and purify the PCR products using a gel extraction kit according to the manufacturer's instructions. Pool all VH, kappa, and lambda subfamilies separately. Determine the DNA concentration. Store the three purified first PCR pools at -20°C .

3.1.4 Second Antibody Gene PCR

- In the second PCR the restriction sites for library cloning will be added. Set up the PCR reactions as follows (30× mastermix for 27 PCR reactions) (*see Note 4*):

Solution or component	Volume	Final concentration
dH ₂ O	2,200 μL	–
Buffer with MgCl ₂ (5×)	600 μL	1×
dNTPs (10 mM each)	60 μL	200 μM each
GoTaq 5 U/μL	15 μL	2.5 U

- Divide the master mix in 900 μL for VH, 700 μL for kappa and 1,100 μL for lambda.
- Add to each of the three reactions the corresponding reverse primers (*see also Table 1*) as follows:

Antibody gene	Primer	Volume	Final concentration
VH	MHIgMCH1scFv-HindIII_r or MHIgGCH1scFv-HindIII_r (10 μM)	18 μL	0.2 μM
kappa	MHKappaCLscFv-NotI_r (10 μM)	14 μL	0.2 μM
lambda	MHLambdaCLscFv-NotI_r (10 μM)	22 μL	0.2 μM

- Add the corresponding PCR products of the first PCR as follows:

VH	900 ng
Kappa	700 ng
Lambda	1,100 ng

- Divide the solutions to 9 (VH), 7 (Kappa), and 11 (Lambda) PCR reactions, each with 98 μL and add 2 μL (10 μM, 0.2 μM final concentration) the subfamily specific forward primer (*see also Table 1*):

VH:	(1) MHVH1-NcoI_f, (2) MHVH2-NcoI_f, (3) MHVH1/7-NcoI_f, (4) MHVH3-NcoI_f1, (5) MHVH3-NcoI_f2, (6) MHVH4-NcoI_f1, (7) MHVH4-NcoI_f2, (8) MHVH5-NcoI_f, (9) MHVH6-NcoI_f
Vkappa:	(10) MHVK1-MluI_f1, (11) MHVK1-MluI_f2, (12) MHVK2-MluI_f, (13) MHVK3-MluI_f, (14) MHVK4-MluI_f, (15) MHVK5-MluI_f, (16) MHVK6-MluI_f

6. Carry out the PCR using the following program:

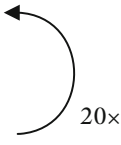
94 °C	1 min	
94 °C	1 min	
57 °C	1 min	
72 °C	1.5 min	
72 °C	10 min	

7. Separate the PCR products by 1.5 % TAE agarose gel electrophoresis, cut out the amplified antibody genes (VH: ~400 bp, kappa/lambda: ~400 bp) and purify the PCR products using a gel extraction kit according to the manufacturer's instructions. Pool all VH, kappa, and lambda subfamilies separately. Determine the DNA concentration. Store the three purified second PCR pools at -20 °C.

3.1.5 First Cloning Step: VL

1. Prepare a plasmid preparation of pHAL14 vector for library cloning (*see Note 5*).
2. Digest the vector and the VL PCR products. Always perform additional single enzyme digestions of the vector in parallel to check whether the digestion is complete (*see Note 6*):

Solution or component	Volume	Final concentration
dH ₂ O	83-x μL	-
pHAL14 or VL	x μL	5 μg or 2 μg
NEB buffer 3 (10×)	10 μL	1×
BSA (100×)	1 μL	1×
NEB MluI (10 U/μL)	3 μL	30 U
NEB NotI (10 U/μL)	3 μL	30 U

3. Incubate at 37 °C for 2 h. Control the digest of the vector by using a 5 µL aliquot on 1 % TAE agarose gel electrophoresis. If the vector is not fully digested, extend the incubation time.
4. Inactivate the enzymes at 65 °C for 10 min.
5. Add 0.5 µL CIP (1 U/µL) and incubate at 37 °C for 30 min. Repeat this step once.
6. Purify the vector and the PCR product using a PCR purification kit according to the manufacturer's instructions and elute with 50 µL elution buffer or water. The short stuffer fragment containing multiple stop codons between MluI and NotI in pHAL14 will be removed. Determine the DNA concentration.
7. Ligate the vector pHAL14 (4,255 bp) and VL (~380 bp) as follows (*see Note 4*):

Solution or component	Volume	Final concentration
dH ₂ O	89-x-yµL	-
pHAL14	xµL	1,000 ng
VL (kappa or lambda)	yµL	270 ng
T4 ligase buffer (10×)	10 µL	1×
T4 ligase (3 U/µL)	1 µL	3 U

8. Incubate at 16 °C overnight.
9. Inactivate the ligation at 65 °C for 10 min.
10. Precipitate the ligation with 260 µL containing 10 µL 3 M sodium acetate pH 5.2 and 250 µL ethanol, incubate for 2 min at RT and centrifuge for 5 min at 16,000×g and 4 °C.
11. Wash the pellet with 500 µL 70 % (v/v) ethanol and pellet the DNA for 2 min at 16,000×g and 4 °C. Repeat this step once and resolve the DNA pellet in 35 µL dH₂O.
12. Thaw 25 µL electrocompetent *E. coli* XLI-Blue MRF on ice and mix with the ligation reaction.
13. Transfer the 60 µL mix to a prechilled 0.1 cm cuvette. Dry the electrode of the cuvette with a tissue paper.
14. Perform a 1.7 kV pulse using an electroporator (*see Note 7*). Immediately, add 1 mL 37 °C prewarmed SOC medium, transfer the suspension to a 2 mL tube and shake for 1 h at 600 rpm and 37 °C.
15. To determine the amount of transformants, use 10 µL (=10⁻² dilution) of the transformation and perform a dilution series down to 10⁻⁶ dilution. Plate out a 10⁻⁶ dilution on 2×TY-GAT agar plates and incubate overnight at 37 °C.
16. Plate out the remaining 990 µL on 2×YT-GAT agar "pizza plate" and incubate overnight at 37 °C.

17. Calculate the amount of transformants, that should be 1×10^6 – 5×10^8 cfu. Control colonies for full size insert by colony PCR (*see* Protocol 3.1.7).
18. Float off the colonies on the “pizza plate” with 40 mL 2×TY medium using a Drigalsky spatula. Use 5 mL bacteria solution for midi plasmid preparation according to the manufacturer’s instructions. Determine the DNA concentration.

3.1.6 Second Cloning
Step: VH

1. Digest the pHAL14-VL repertoire and the VH PCR products. Always perform additional single enzyme digestions of the vector in parallel (*see* Note 6):

Solution or component	Volume	Final concentration
dH ₂ O	81– <i>x</i> μL	–
pHAL14-VL or VH	<i>x</i> μL	5 μg or 2 μg
NEB buffer 4 (10×)	10 μL	1×
BSA (100×)	1 μL	1×
NEB NcoI-HF (20 U/μL)	1.5 μL	30 U
NEB HindIII-HF (20 U/μL)	1.5 μL	30 U

2. Incubate at 37 °C for 2 h (*see* Note 8). Control the digest of the vector by using a 5 μL aliquot on 1 % agarose gel electrophoresis.
3. Inactivate the digestion at 80 °C for 20 min.
4. Add 0.5 μL CIP (1 U/μL) and incubate at 37 °C for 30 min. Repeat this step once.
5. Purify the vector and the PCR product using a PCR purification kit according to the manufacturer’s instructions and elute with 50 μL elution buffer or water. The short stuffer fragment between NcoI and HindII in pHAL14 will be removed. Determine the DNA concentration.
6. Ligate the vector pHAL14-VL (~4,610 bp) and VH (~380 bp) as follows (*see* Note 4):

Solution or component	Volume	Final concentration
dH ₂ O	89– <i>x</i> – <i>y</i> μL	–
pHAL14	<i>x</i> μL	1,000 ng
VH	<i>y</i> μL	250 ng
T4 ligase buffer (10×)	10 μL	1×
T4 ligase (3 U/μL)	1 μL	3 U

7. Incubate at 16 °C overnight.

8. Inactivate the ligation at 65 °C for 10 min.
9. Precipitate the ligation with 260 µL containing 10 µL 3 M pH 5.2 sodium acetate and 250 µL ethanol, incubate for 2 min at RT and centrifuge for 5 min at 16,000×*g* and 4 °C.
10. Wash the pellet with 500 µL 70 % (v/v) ethanol and pellet the DNA for 2 min at 16,000×*g* and 4 °C. Repeat this step once and resolve the pellet in 35 µL dH₂O.
11. Thaw 25 µL electrocompetent *E. coli* XLI-Blue MRF on ice and mix with the ligation reaction.
12. Transfer the 60 µL mix to a prechilled 0.1 cm cuvette. Dry the electrode of the cuvette with a tissue paper.
13. Perform a 1.7 kV pulse using an electroporator (*see Note 7*). Immediately, add 1 mL 37 °C prewarmed SOC medium, transfer to a 2 mL cap and incubate for 1 h at 600 rpm.
14. To determine the amount of transformants, use 10 µL (=10⁻² dilution) of the transformation and perform a dilution series down to 10⁻⁶ dilution. Plate out a 10⁻⁶ dilution on 2×TY-GAT agar plates and incubate overnight at 37 °C.
15. Plate out the remaining 990 µL on 2×TY-GAT agar “pizza plate” and incubate overnight at 37 °C.
16. Calculate the amount of transformants (1×10⁶–5×10⁸ should be reached to be included into the final library). Control colonies for full size insert by colony PCR (*see Protocol 3.1.7*).
17. Float off the colonies on the “pizza plate” with 25 mL 2×TY medium using a Drigalsky spatula (~OD 20–25 = ~2×10¹⁰ cells/mL). Use 800 µL bacteria solution (~1×10¹⁰ bacteria) and 200 µL glycerol for glycerol stocks. Make 5–20 glycerol stocks per sublibrary and store at –80 °C.
18. When all transformations are done, thaw one aliquot of each sublibrary on ice, mix all sublibraries and make new aliquots for storage at –80 °C (*see Note 9*).

3.1.7 Colony PCR

1. Choose 10–20 single colonies per transformation. Set up the 10 µL PCR reaction per colony as follows (*see Table 1* for primer sequences):

Solution or component	Volume	Final concentration
dH ₂ O	7.5 µL	
GoTaq buffer (5×)	2 µL	1×
dNTPs (10 mM each)	0.2 µL	Each 200 µM
MHLacZPro_f 10 µM	0.1 µL	0.1 µM
MHgIII_r 10 µM	0.1 µL	0.1 µM
GoTag (5 U/µL)	0.1 µL	0.5 U
Template	Picked colonies from dilution plate	

2. Control the PCR by 1.5 % TAE agarose gel electrophoresis.
3. The PCR products should be ~1,100 bp when including VH and VL, ~750 bp when including only VL or VH and 375 bp if the vector contains no insert. Each used sublibrary should have more than 80 % full-size inserts to be included into the final library.

3.1.8 Library Packaging and scFv Phage Production

1. To package the library, inoculate 400 mL 2×TY-GA in a 1 L Erlenmeyer flask with 1 mL antibody gene library stock. Grow at 250 rpm at 37 °C up to an $OD_{600nm} \sim 0.5$.
2. Infect 25 mL bacteria culture ($\sim 1.25 \times 10^{10}$ cells) with 2.5×10^{11} colony forming units (cfu) of the helperphage M13K07 or Hyperphage according to a multiplicity of infection (moi) = 1:20 (*see Note 10*). Incubate 30 min without shaking and the following 30 min with 250 rpm at 37 °C.
3. To remove the glucose which represses the lac promoter of pHAL14 and therefore the scFv::pIII fusion protein expression, harvest the cells by centrifugation for 10 min at $3,200 \times g$ in 50 mL polypropylene tubes.
4. Resuspend the pellet in 400 mL 2×TY-AK in a 1 L Erlenmeyer flask. Produce scFv-phage overnight at 250 rpm and 30 °C.
5. Pellet the bacteria by centrifugation for 10 min at $10,000 \times g$ in two GS3 centrifuge tubes. If the supernatant is not clear, centrifuge again to remove remaining bacteria.
6. Precipitate the phage from the supernatant by adding 1/5 volume PEG solution in two GS3 tubes. Incubate for 1 h at 4 °C with gentle shaking, followed by centrifugation for 1 h at $10,000 \times g$.
7. Discard the supernatant, resolve each pellet in 10 mL phage dilution buffer in SS34 centrifuge tubes and add 1/5 volume PEG solution.
8. Incubate on ice for 20 min and pellet the phage by centrifugation for 30 min at $10,000 \times g$.
9. Discard the supernatant and put the open tubes upside down on tissue paper. Let the viscous PEG solution move out completely. Resuspend the phage pellet in 1 mL phage dilution buffer. Titer the phage preparation (*see Subheading 3.2.4*). Store the packaged antibody phage library at 4 °C.
10. The library packaging should be controlled by 10 % SDS-PAGE, Western Blot and anti-pIII immunostain (mouse anti-pIII 1:2,000, goat anti-mouse IgG AP conjugate 1:10,000). Wild-type pIII has a calculated molecular mass of 42.5 kDa, but it runs at an apparent molecular mass of 65 kDa in SDS-PAGE. Accordingly, the scFv:pIII fusion protein runs at about 95 kDa.

3.2 Antibody Selection (Panning)

The in vitro procedure for isolation of antibody fragments by their binding activity was called “panning,” referring to the gold washers tool [75]. In principle, the antigen is immobilized to a solid surface, such as nitrocellulose [76], magnetic beads [77], column matrixes [40] or, most widely used plastic surfaces with high protein binding capacity as polystyrole tubes, respectively microtiter wells [78]. The antibody phage are incubated with the surface-bound antigen, followed by stringent washing to remove the vast excess of nonbinding antibody phage. Subsequently, the bound antibody phage will be eluted and reamplified by infection of *E. coli*. The selection cycle will be repeated by infection of the phagemid-bearing *E. coli* colonies from the former panning round with a helperphage to produce new antibody phage, which can be used for further panning rounds until a significant enrichment of antigen specific phage is achieved. The number of antigen specific antibody phage clones should increase with every panning round. Usually 2–3 panning rounds, sometimes up to 6, are necessary to select specifically binding antibody fragments.

The first step in the evaluation process of potential binders is often done—but not a requisite—by an ELISA of the polyclonal phage preparations from each panning round against the target antigen and negative control proteins, e. g. BSA. We recommend this assay only for troubleshooting and not for routine use [79]. For screening of monoclonal binders, scFvs are produced as soluble monoclonal antibody fragments in microtiter plates followed by an antigen ELISA. An ELISA with monoclonal phage preparations should be omitted, because antibody clones that bind only as scFv-phage or scFv-pIII fusion but not as soluble scFv fragment are identified [80, 81], resulting in artifacts.

The following protocols describe the panning and the screening of the selected antibody fragments completely in microtiter plates (MTPs). A classic protocol by plating the infected bacteria after elution during the panning can be found in an earlier publication [79].

3.2.1 Coating of Microtiter Plate Wells

1. (A) Protein antigen: For the first panning round, use 2–10 µg protein/well per panning, for the following rounds use 0.1–1 µg protein/well for more stringent conditions. Dissolve the antigen in 150 µL PBS and incubate it in a polystyrole (PS) microtiter plate well (MTP) overnight at 4 °C (*see Note 11*).
- (B) Oligopeptide antigen: Use 500–1,000 ng oligopeptide for each panning round. Dissolve the oligopeptide in 150 µL PBS, transfer into a streptavidin-coated MTP well and incubate overnight at 4 °C (*see Note 12*).
2. Wash the coated microtiter plate wells 3× with PBST using an ELISA washer (*see Note 13*).

3.2.2 Panning

1. (A) Block the antigen-coated MTP wells with MPBST for 2 h at RT. The wells must be completely filled. Afterwards, wash the blocked antigen-coated wells 3× with PBST (*see Note 13*).
(B) *You need to perform this step only in the first panning round but we suggest to perform this step also in following rounds!* In parallel, block an additional MTP well (without antigen!) per panning with MPBST for 1 h at RT for preincubation of the antibody gene library. The MTP wells must be completely filled. When using biotinylated antigens, use a streptavidin MTP well. Wash 3× with PBST (*see Note 13*). Incubate 10^{11} – 10^{12} antibody phage (you should use ~100× more phage particles compared to the library size) from the library in 50 µL panning block for 1 h at RT (*see Note 14*). This step removes unspecific binders which often occur from the antibody gene libraries due to incorrect folding of individual antibodies.
2. Carry over the preincubated antibody phage library to the blocked MTP wells or fill 10^{11} – 10^{12} amplified phage solved in 50 µL panning block from the first or second panning round in the blocked MTP wells. Incubate at RT for 2 h for binding of the antibody phage. When using biotinylated antigens add 50 µg streptavidin for competition per MTP well.
3. Remove the nonspecifically bound antibody phage by stringent washing. Therefore, wash the wells 10× with an ELISA washer in the first panning round. In the following panning rounds increase the number of washing steps (20× in the second panning round, 30× in the third panning round...) (*see Note 13*).
4. Elute bound antibody phage with 50 µL Trypsin solution for 30 min at 37 °C (*see Note 15*).
5. After the third panning round, use 10 µL of the eluted phage for titration (*see Subheading 3.2.3*).
6. Inoculate 50 mL 2×TY-T with an overnight culture of *E. coli* XL1-Blue MRF in 100 mL Erlenmeyer flasks and grow at 250 rpm and 37 °C to OD₆₀₀ 0.4–0.5 (*see Note 16*).
7. Fill 130 µL exponentially growing *E. coli* in a polypropylene (PP) MTP well and inoculate with 50 µL of the XL1-Blue MRF overnight culture. Incubate the bacteria for 30 min at 37 °C without shaking. Afterwards add 20 µL of 10×GA and incubate overnight at 37 °C and 850 rpm (*see Note 17*).
8. Fill 180 µL 2×TY-GA in a MTP well and add 10 µL of the overnight culture. Grow the phagemid-bearing bacteria for 2 h at 37 °C and 850 rpm (the bacteria should reach OD_{~600} = 0.5).
9. Infect the bacteria with 10 µL M13K07 helperphage (2×10^{11} phage particles/mL = 2×10^9 phage particles, MOI 1:20). Incubate for 30 min at 37 °C without shaking, followed by 30 min at 37 °C at 850 rpm.

10. Centrifuge the MTP plate at $3,220\times g$. Remove 180 μL supernatant with a pipette. Do not destroy the pellet.
11. Produce scFv-phage by adding 180 μL 2 \times TY-AK and incubation overnight at 30 °C and 800 rpm.
12. Centrifuge the MTP plate at $3,220\times g$. Transfer the supernatant ($\sim 1\times 10^{12}$ scFv-phage/mL) into a new PP MTP. The supernatant can directly be used for the next panning round.

3.2.3 Phage Titration

1. Inoculate 5 mL 2 \times TY-T in a 100 mL Erlenmeyer flask with *E. coli* XL1-Blue MRF' and grow overnight at 37 °C and 250 rpm (*see Note 18*).
2. Inoculate 50 mL 2 \times TY-T with 500 μL overnight culture and grow at 250 rpm at 37 °C up to $\text{OD}_{600}\sim 0.5$ (*see Note 16*).
3. Make serial dilutions of the phage suspension in PBS. The number of eluted phages depends on several parameters (e.g. antigen, library, panning round, and washing stringency). In case of a successful enrichment, the titer of eluted phage usually is 10^3 – 10^5 phage per well after the first panning round and increases two to three orders in magnitude per each additional panning round. The phage preparation after reamplification of the eluted phage have a titer of about 10^{12} – 10^{14} phage/mL.
4. Infect 50 μL bacteria with 10 μL phage dilution and incubate 30 min at 37 °C.
5. You can perform titrations in two different ways:
 - (A) plate the 60 μL infected bacteria on 2 \times TY-GA agar plates (9 cm petri dishes).
 - (B) pipet 10 μL (in triplicate) on 2 \times TY-GA agar plates. Here, about 20 titering spots can be placed on one 9 cm petri dish. Dry drops under work bench.
6. Incubate the plates overnight at 37 °C.
7. Count the colonies and calculate the cfu/mL titer according to the dilution.

3.2.4 Production of Soluble Monoclonal Antibody Fragments in Microtiter Plates

1. Fill each well of a 96 well U-bottom PP MTP with 150 μL 2 \times TY-GA.
2. Pick 92 clones with sterile tips from the third panning round and inoculate each well (*see Note 19*). Seal the plate with a breathable sealing film.
3. Incubate overnight in a microtiter plate shaker at 37 °C and 1,000 rpm.
4. (A) Fill a new 96 well polypropylene microtiter plate with 150 μL 2 \times TY-GA and add 10 μL of the overnight cultures. Incubate for 2 h at 37 °C and 1,000 rpm.

(B) Add 30 μL glycerol solution to the remaining 140 μL overnight cultures. Mix by pipetting and store this master-plate at $-80\text{ }^{\circ}\text{C}$.

5. Pellet the bacteria in the microtiter plates by centrifugation for 10 min at $3,200\times g$ and $4\text{ }^{\circ}\text{C}$. Remove 180 μL glucose containing medium by carefully pipetting (do not disturb the pellet).
6. Add 180 μL buffered $2\times\text{TY-SAI}$ and incubate overnight at $30\text{ }^{\circ}\text{C}$ and 1,000 rpm (*see Note 20*).
7. Pellet the bacteria by centrifugation for 10 min at $3,200\times g$ in the microtiter plates. Transfer the antibody fragment containing supernatant to a new polypropylene microtiter plate and store at $4\text{ }^{\circ}\text{C}$.

3.2.5 ELISA of Soluble Monoclonal Antibody Fragments

1. To analyze the antigen specificity of the monoclonal soluble antibody fragments, coat 100–1,000 ng antigen per well overnight at $4\text{ }^{\circ}\text{C}$. As control coat 100–1,000 ng BSA or streptavidin per well (for coating *see* Subheading 3.2.1).
2. Wash the coated microtiter plate wells $3\times$ with PBST (washing procedure *see* Subheading 3.2.1 and **Note 13**).
3. Block the antigen-coated wells with MPBST for 2 h at RT. The wells must be completely filled.
4. Fill 50 μL MPBST in each well and add 50 μL of antibody solution (*see* Subheading 3.2.4). Incubate for 1.5 h at RT (or overnight at $4\text{ }^{\circ}\text{C}$).
5. Wash the microtiter plate wells $3\times$ with PBST as above.
6. Incubate 100 μL mouse 9E10 anti-myc tag antibody solution for 1.5 h (appropriate dilution in MPBST).
7. Wash the microtiter plate wells $3\times$ with PBST as above.
8. Incubate 100 μL goat anti-mouse HRP conjugate (1:10,000 in MPBST).
9. Wash the microtiter plate wells $3\times$ with PBST.
10. Shortly before use, mix 19 parts TMB substrate solution A and 1 part TMB substrate solution B. Add 100 μL of this TMB solution into each well and incubate for 1–15 min.
11. Stop the color reaction by adding 100 μL 1 N sulphuric acid. The color turns from blue to yellow.
12. Measure the extinction at 450 nm using an ELISA reader.
13. Identify positive candidates with a signal (on antigen) $10\times$ over noise (on control protein, e.g. BSA) (*see Note 21*).

4 Notes

1. Be careful with human blood samples since they are potentially infectious (HIV, hepatitis, etc.)!
2. Both methods, mRNA or total RNA isolation, work well.
3. The VH amplifications of VH subfamilies sometimes result also in longer PCR products. Cut out only the ~380 bp fragment. The amplifications of kappa subfamilies should always give a clear ~650 bp fragment (complete light chain). When amplifying lambda subfamilies often other PCR products are generated, especially the amplification of the lambda 2 subfamily results often in slushy bands. If some subfamilies are bad amplified and no clear ~650 bp fragment is detectable, use only the ~650 bp fragments from the well amplified subfamilies. Additional comment: since the first PCR amplifies the full LC, it can be used also to construct Fab or scFab [82] libraries from this material.
4. For a very large naive antibody gene library perform as many PCRs as sufficient to perform 20 light chains ligations/transformations and about 100 VH ligations. For an immune library 4 light chains ligations/transformations and 8 VH ligations are usually sufficient. Prepare and digest also adequate amounts of pHAL14 and VL for the first cloning step and pHAL14-VL library and VH for the second cloning step. Keep kappa and lambda libraries in all steps (cloning, packaging) separately and mix only after phage production before panning.
5. The vector pHAL30 is a modified version of pHAL14. In pHAL30 the orientation of the tags is Myc-His instead of His-Myc resulting in a higher scFv production rate (unpublished results).
6. Always perform single digests using only one enzyme in parallel, to control the success of the restriction reaction. Analyze the digestion by TAE agarose gel electrophoresis by comparing with the undigested plasmid. Use only material where both single digests are successful and where no degradation is visible in the double digest.
7. The pulse time should be between 4 and 5 ms for optimal electroporation efficiency.
8. Often the HindIII digestion is incomplete after 2 h. Then, inactivate the enzymes by heating up to 65 °C for 10 min, add additional 5 µL of HindIII and incubate overnight. You can use also higher concentrated HindIII. Alternative: perform the NcoI digest first for 2 h, inactivate the digest, and afterwards perform the HindIII digest. This problem only occurs when HindIII is used and not if HindIII-HF.

9. To minimize loss of diversity, avoid too many freeze and thaw steps, e.g. when constructing an immune library make eight transformations in parallel and directly package the immune library. When making a big immune library, combine only a glycerin stock of each sublibrary which corresponds to maximum 2×10^9 independent clones to ensure that the library diversity can be kept when packaging 1 mL of mixed library glycerin stock. When the library size is bigger than 2×10^9 independent clones, do not package the library as complete library, package “blocks” of sublibraries. Combine the phage particles of each “block” before panning to get the final complete library.
10. The use of Hyperphage as helperphage instead of M13K07 offers oligovalent phage display, facilitates the selection of specific binders in the first and most critical panning round by avidity effect [18, 83–85]. The Hyperphage should be only used for library packaging. For the following panning rounds use M13K07 to enhance the stringency of the panning process.
11. If the protein is not binding properly to the microtiter plate surface, try bicarbonate buffer (50 mM NaHCO_3 , pH 9.6).
12. More hydrophobic oligopeptides may need to be dissolved in PBS containing 5 % DMSO. If biotinylated oligopeptides are used as antigen for panning, dissolve 200 ng Streptavidin in 150 μL PBS and coat overnight at 4 °C. Coat two wells for each panning, one well is for the panning, the second one for the preincubation of the library to remove streptavidin binders! It is necessary to use free streptavidin during panning for competition to remove streptavidin binders. Pour out the wells and wash 3 \times with PBST. Dissolve 100–500 ng biotinylated oligopeptide in PBS and incubate for 1 h at RT. Alternatively, oligopeptides with a terminal cysteine residue can be coupled to BSA and coated overnight at 4 °C.
13. The washing should be performed with an ELISA washer (e. g. TECAN Columbus Plus) to increase the stringency and reproducibility. To remove antigen or blocking solutions wash 3 \times with PBST (“standard washing protocol” for TECAN washer). If no ELISA washer is available, wash manually 3 \times with PBST.
After binding of antibody phage, wash 10 \times with PBST (“stringent bottom washing protocol” in case of TECAN washer). If no ELISA washer is available, wash manually 10 \times with PBST and 10 \times with PBS. For stringent off-rate selection increase the number of washing steps or additionally incubate the microtiter plate in 1 L PBS for several days.
14. Antibody phage which bind unspecifically are usually enriched during panning. These unspecific binding often results from

misfolded or incomplete antibodies. They often bind to BSA, Streptavidin, and plastic surfaces.

15. Phagemids like pSEX81 [63] or pHAL14 [10, 85] have coding sequences for a trypsin-specific cleavage site between the antibody fragment gene and the gIII. Trypsin also cleaves within antibody fragments but does not degrade the phage particles including the pIII that mediates the binding of the phage to the F pili of *E. coli* required for the infection. We observed that proteolytic cleavage of the antibody fragments from the antibody::pIII fusion by trypsin increases not only the elution but also enhances the infection rate of eluted phage particles, especially when using Hyperphage as helperphage.
16. If the bacteria have reached OD₆₀₀ ~ 0.5 before they are needed, store the culture immediately on ice to maintain the F pili on the *E. coli* cells for several hours. M13K07 helperphage (kan⁺) or other scFv-phage (amp⁺) can be used as positive control to check the infectibility of the *E. coli* cells.
17. The high concentration of glucose is necessary to efficiently repress the lac promoter controlling the antibody::pIII fusion gene on the phagemid. Low glucose concentrations lead to an inefficient repression of the lac promoter and background expression of the antibody::pIII fusion protein. Background antibody expression is a strong selection pressure frequent causing mutations in the phagemid, especially in the promoter region and the antibody::pIII fusion gene. Bacteria with this kind of mutations in the phagemids proliferate faster than bacteria with nonmutated phagemids. Therefore, the 100 mM glucose must be included in every step of *E. coli* cultivation except during the phage production!
18. For troubleshooting, analyze the titer of the eluted phage particles after each panning round. When the antibody gene library was packaged using Hyperphage, the titer of the eluted phage after the second panning may not increase as strongly or even decreases slightly due to the change from oligovalent to monovalent display.
19. We recommend to pick 92 clones. Use the wells H3, H6, H9, and H12 for controls. H3 and H6 are negative controls: these wells will not be inoculated and not used for the following ELISA with soluble antibodies. We inoculate the wells H9 and H12 with a clone containing a phagemid encoding a known antibody fragment. In ELISA, the wells H9 and H12 are coated with the antigen corresponding to the control antibody fragment in order to check scFv production and ELISA.
20. The appropriate IPTG concentration for induction of antibody or antibody::pIII expression depends on the vector design. A concentration of 50 μM was well suited for vectors with a Lac promoter like pSEX81 [63], pIT2 [86], pHENIX [87],

and pHAL14 [10, 18, 85]. The method for the production of soluble antibodies works with vectors with (e.g. pHAL14) and without (e.g. pSEX81) an amber stop codon between antibody fragment and gIII. If the vector has no amber stop codon the antibody::pIII fusion protein will be produced [88]. Buffered culture media and the addition of saccharose enhances the production of many but not all scFvs [89]. We observed that antibody::pIII fusion proteins and antibody phage sometimes show differences in antigen binding in comparison to soluble antibody fragments, because some antibodies can bind the corresponding antigen only as pIII fusion. Therefore, we recommend to perform the screening procedure only by using soluble antibody fragment, to avoid false positive binders.

21. The background (noise) signals should be about $OD_{450} \sim 0.02$ after 5–30 min TMB incubation time.

Acknowledgements

We thank Stefan Dübel for discussion and corrections on the manuscript. We gratefully acknowledge the financial support by the FP7 collaborative projects AffinityProteome (contract 222635) and AFFINOMICS (contract 241481). This review is an updated and revised version of [54, 79] and the professorial dissertation (Habilitation) of Michael Hust.

References

1. Wheeler DA, Srinivasan M, Egholm M, Shen Y, Chen L, McGuire A, He W, Chen Y-J, Makhijani V, Roth GT, Gomes X, Tartaro K, Niazi F, Turcotte CL, Irzyk GP, Lupski JR, Chinault C, Song X, Liu Y, Yuan Y, Nazareth L, Qin X, Muzny DM, Margulies M, Weinstock GM, Gibbs RA, Rothberg JM (2008) The complete genome of an individual by massively parallel DNA sequencing. *Nature* 452:872–876
2. Levy S, Sutton G, Ng PC, Feuk L, Halpern AL, Walenz BP, Axelrod N, Huang J, Kirkness EF, Denisov G, Lin Y, MacDonald JR, Pang AWC, Shago M, Stockwell TB, Tsiamouri A, Bafna V, Bansal V, Kravitz SA, Busam DA, Beeson KY, McIntosh TC, Remington KA, Abril JF, Gill J, Borman J, Rogers Y-H, Frazier ME, Scherer SW, Strausberg RL, Venter JC (2007) The diploid genome sequence of an individual human. *PLoS Biol* 5:e254
3. Harrison PM, Kumar A, Lang N, Snyder M, Gerstein M (2002) A question of size: the eukaryotic proteome and the problems in defining it. *Nucleic Acids Res* 30:1083–1090
4. Bradbury ARM, Sidhu S, Dübel S, McCafferty J (2011) Beyond natural antibodies: the power of in vitro display technologies. *Nat Biotechnol* 29:245–254
5. Colwill K, Persson H, Jarvik NE, Wyrzucki A, Wojcik J, Koide A, Kossiakoff AA, Koide S, Sidhu S, Dyson MR, Pershad K, Pavlovic JD, Karatt-Vellatt A, Schofield DJ, Kay BK, McCafferty J, Mersmann M, Meier D, Mersmann J, Helmsing S, Hust M, Dübel S, Berkowicz S, Freemantle A, Spiegel M, Sawyer A, Layton D, Nice E, Dai A, Rocks O, Williton K, Fellouse FA, Hersi K, Pawson T, Nilsson P, Sundberg M, Sjöberg R, Sivertsson A, Schwenk JM, Takanen JO, Hober S, Uhlén M, Dahlgren L-G, Flores A, Johansson I, Weigelt J, Crombet L, Loppnau P, Kozieradzki I, Cossar D, Arrowsmith CH, Edwards AM, Gräslund S (2011) A roadmap to generate renewable protein binders to the human proteome. *Nat Methods* 8(7):551–558

6. Hust M, Dübel S (2004) Mating antibody phage display with proteomics. *Trends Biotechnol* 22:8–14
7. Ohara R, Knappik A, Shimada K, Frisch C, Ylera F, Koga H (2006) Antibodies for proteomic research: comparison of traditional immunization with recombinant antibody technology. *Proteomics* 6:2638–2646
8. Taussig MJ, Stoevesandt O, Borrebaeck CAK, Bradbury AR, Cahill D, Cambillau C, de Daruvar A, Dübel S, Eichler J, Frank R, Gibson TJ, Gloriam D, Gold L, Herberg FW, Hermjakob H, Hoheisel JD, Joos TO, Kallioniemi O, Koegl M, Konthur Z, Korn B, Kremmer E, Krobitsch S, Landegren U, van der Maarel S, McCafferty J, Muyldermans S, Nygren P-A, Palcy S, Plückthun A, Polic B, Przybylski M, Saviranta P, Sawyer A, Sherman DJ, Skerra A, Templin M, Ueffing M, Uhlén M (2007) ProteomeBinders: planning a European resource of affinity reagents for analysis of the human proteome. *Nat Methods* 4:13–17
9. Wingren C, James P, Borrebaeck CAK (2009) Strategy for surveying the proteome using affinity proteomics and mass spectrometry. *Proteomics* 9:1511–1517
10. Hust M, Meyer T, Voedisch B, Rülker T, Thie H, El-Ghezal A, Kirsch MI, Schütte M, Helmsing S, Meier D, Schirrmann T, Dübel S (2011) A human scFv antibody generation pipeline for proteome research. *J Biotechnol* 152:159–170
11. Mersmann M, Meier D, Mersmann J, Helmsing S, Nilsson P, Gräslund S, Colwill K, Hust M, Dübel S, Structural Genomics Consortium (2010) Towards proteome scale antibody selections using phage display. *Nat Biotechnol* 27:118–128
12. Pershad K, Pavlovic JD, Gräslund S, Nilsson P, Colwill K, Karatt-Vellatt A, Schofield DJ, Dyson MR, Pawson T, Kay BK, McCafferty J (2010) Generating a panel of highly specific antibodies to 20 human SH2 domains by phage display. *Protein Eng Des Sel* 23:279–288
13. Meyer T, Stratmann-Selke J, Meens J, Schirrmann T, Gerlach GF, Frank R, Dübel S, Strutzberg-Minder K, Hust M (2011) Isolation of scFv fragments specific to OmpD of *Salmonella typhimurium*. *Vet Microbiol* 147:162–169
14. Pitaksajakul P, Lekcharoensuk P, Upragarin N, Barbas CF, Ibrahim MS, Ikuta K, Ramasoota P (2010) Fab MAbs specific to HA of influenza virus with H5N1 neutralizing activity selected from immunized chicken phage library. *Biochem Biophys Res Commun* 395:496–501
15. Schütte M, Thullier P, Pelat T, Wezler X, Rosenstock P, Hinz D, Kirsch MI, Hasenberg M, Frank R, Schirrmann T, Gunzer M, Hust M, Dübel S (2009) Identification of a putative Crf splice variant and generation of recombinant antibodies for the specific detection of *Aspergillus fumigatus*. *PLoS One* 4:e6625
16. Dübel S (2007) Recombinant therapeutic antibodies. *Appl Microbiol Biotechnol* 74:723–729
17. Chahboun S, Hust M, Liu Y, Pelat T, Miethe S, Helmsing S, Jones RG, Sesardic D, Thullier P (2011) Isolation of a nanomolar scFv inhibiting the endopeptidase activity of botulinum toxin A, by single-round panning of an immune phage-displayed library of macaque origin. *BMC Biotechnol* 11:113
18. Pelat T, Hust M, Laffly E, Condemine F, Bottex C, Vidal D, Lefranc M-P, Dübel S, Thullier P (2007) High-affinity, human antibody-like antibody fragment (single-chain variable fragment) neutralizing the lethal factor (LF) of *Bacillus anthracis* by inhibiting protective antigen-LF complex formation. *Antimicrob Agents Chemother* 51:2758–2764
19. Pelat T, Hust M, Hale M, Lefranc M-P, Dübel S, Thullier P (2009) Isolation of a human-like antibody fragment (scFv) that neutralizes ricin biological activity. *BMC Biotechnol* 9:60
20. Alonso-Ruiz A, Pijoan JL, Ansuategui E, Urkaregi A, Calabozo M, Quintana A (2008) Tumor necrosis factor alpha drugs in rheumatoid arthritis: systematic review and metaanalysis of efficacy and safety. *BMC Musculoskelet Disord* 9:52
21. Peeters M, Price T, Van Laethem J-L (2009) Anti-epidermal growth factor receptor monotherapy in the treatment of metastatic colorectal cancer: where are we today? *Oncologist* 14:29–39
22. Chatenoud L, Bluestone JA (2007) CD3-specific antibodies: a portal to the treatment of autoimmunity. *Nat Rev Immunol* 7:622–632
23. Adams GP, Weiner LM (2005) Monoclonal antibody therapy of cancer. *Nat Biotechnol* 23:1147–1157
24. Moss ML, Sklair-Tavron L, Nudelman R (2008) Drug insight: tumor necrosis factor-converting enzyme as a pharmaceutical target for rheumatoid arthritis. *Nat Clin Pract Rheumatol* 4:300–309
25. Dalle S, Thieblemont C, Thomas L, Dumontet C (2008) Monoclonal antibodies in clinical oncology. *Anticancer Agents Med Chem* 8:523–532
26. Jones SE (2008) Metastatic breast cancer: the treatment challenge. *Clin Breast Cancer* 8:224–233
27. Osbourn J, Groves M, Vaughan T (2005) From rodent reagents to human therapeutics using antibody guided selection. *Methods* 36:61–68

28. Getts DR, Getts MT, McCarthy DP, Chastain EML, Miller SD (2010) Have we overestimated the benefit of human(ized) antibodies? *MABs* 2:682–694
29. Harding FA, Stickler MM, Razo J, DuBridg RB (2010) The immunogenicity of humanized and fully human antibodies: residual immunogenicity resides in the CDR regions. *MABs* 2:256–265
30. Fishwild DM, O'Donnell SL, Bengoechea T, Hudson DV, Harding F, Bernhard SL, Jones D, Kay RM, Higgins KM, Schramm SR, Lonberg N (1996) High-avidity human IgG kappa monoclonal antibodies from a novel strain of minilocus transgenic mice. *Nat Biotechnol* 14:845–851
31. Jakobovits A (1995) Production of fully human antibodies by transgenic mice. *Curr Opin Biotechnol* 6:561–566
32. Kuroiwa Y, Kasinathan P, Choi YJ, Naeem R, Tomizuka K, Sullivan EJ, Knott JG, Duteau A, Goldsby RA, Osborne BA, Ishida I, Robl JM (2002) Cloned transchromosomal calves producing human immunoglobulin. *Nat Biotechnol* 20:889–894
33. Lonberg N, Huszar D (1995) Human antibodies from transgenic mice. *Int Rev Immunol* 13:65–93
34. Kay J, Matteson EL, Dasgupta B, Nash P, Durez P, Hall S, Hsia EC, Han J, Wagner C, Xu Z, Viswanathan S, Rahman MU (2008) Golimumab in patients with active rheumatoid arthritis despite treatment with methotrexate: a randomized, double-blind, placebo-controlled, dose-ranging study. *Arthritis Rheum* 58:964–975
35. Moroni M, Veronese S, Benvenuti S, Marrapese G, Sartore-Bianchi A, Di Nicolantonio F, Gambacorta M, Siena S, Bardelli A (2005) Gene copy number for epidermal growth factor receptor (EGFR) and clinical response to antiEGFR treatment in colorectal cancer: a cohort study. *Lancet Oncol* 6:279–286
36. Winter G, Milstein C (1991) Man-made antibodies. *Nature* 349:293–299
37. Huse WD, Sastry L, Iverson SA, Kang AS, Alting-Mees M, Burton DR, Benkovic SJ, Lerner RA (1989) Generation of a large combinatorial library of the immunoglobulin repertoire in phage lambda. *Science* 246:1275–1281
38. Smith GP (1985) Filamentous fusion phage: novel expression vectors that display cloned antigens on the virion surface. *Science* 228:1315–1317
39. Barbas CF, Kang AS, Lerner RA, Benkovic SJ (1991) Assembly of combinatorial antibody libraries on phage surfaces: the gene III site. *Proc Natl Acad Sci USA* 88:7978–7982
40. Breitling F, Dübel S, Seehaus T, Klewinghaus I, Little M (1991) A surface expression vector for antibody screening. *Gene* 104:147–153
41. Clackson T, Hoogenboom HR, Griffiths AD, Winter G (1991) Making antibody fragments using phage display libraries. *Nature* 352:624–628
42. Hoogenboom HR, Griffiths AD, Johnson KS, Chiswell DJ, Hudson P, Winter G (1991) Multi-subunit proteins on the surface of filamentous phage: methodologies for displaying antibody (Fab) heavy and light chains. *Nucleic Acids Res* 19:4133–4137
43. Marks JD, Hoogenboom HR, Bonnert TP, McCafferty J, Griffiths AD, Winter G (1991) By-passing immunization. Human antibodies from V-gene libraries displayed on phage. *J Mol Biol* 222:581–597
44. McCafferty J, Griffiths AD, Winter G, Chiswell DJ (1990) Phage antibodies: filamentous phage displaying antibody variable domains. *Nature* 348:552–554
45. Hoet RM, Cohen EH, Kent RB, Rookey K, Schoonbroodt S, Hogan S, Rem L, Frans N, Daukandt M, Pieters H, van Hegelsom R, Neer NC, Nastri HG, Rondon IJ, Leeds JA, Hufton SE, Huang L, Kashin I, Devlin M, Kuang G, Steukers M, Viswanathan M, Nixon AE, Sexton DJ, Hoogenboom HR, Ladner RC (2005) Generation of high-affinity human antibodies by combining donor-derived and synthetic complementarity-determining-region diversity. *Nat Biotechnol* 23:344–348
46. Holt LJ, Herring C, Jespers LS, Woolven BP, Tomlinson IM (2003) Domain antibodies: proteins for therapy. *Trends Biotechnol* 21:484–490
47. Hust M, Dübel S (2010) Human antibody gene libraries. In: *Antibody engineering*. Springer, Heidelberg, pp 65–84
48. Mazor Y, Van Blarcom T, Mabry R, Iverson BL, Georgiou G (2007) Isolation of engineered, full-length antibodies from libraries expressed in *Escherichia coli*. *Nat Biotechnol* 25:563–565
49. Simmons LC, Reilly D, Klimowski L, Raju TS, Meng G, Sims P, Hong K, Shields RL, Damico LA, Rancatore P, Yansura DG (2002) Expression of full-length immunoglobulins in *Escherichia coli*: rapid and efficient production of aglycosylated antibodies. *J Immunol Methods* 263:133–147
50. Hanes J, Plückthun A (1997) In vitro selection and evolution of functional proteins by using ribosome display. *Proc Natl Acad Sci USA* 94:4937–4942
51. He M, Taussig MJ (1997) Antibody-ribosome-mRNA (ARM) complexes as efficient selection particles for in vitro display and evolution of antibody combining sites. *Nucleic Acids Res* 25:5132–5134
52. Roberts RW, Szostak JW (1997) RNA-peptide fusions for the in vitro selection of peptides

- and proteins. *Proc Natl Acad Sci USA* 94:12297–12302
53. Boder ET, Wittrup KD (1997) Yeast surface display for screening combinatorial polypeptide libraries. *Nat Biotechnol* 15:553–557
 54. Frenzel A, Fröde D, Meyer T, Schirrmann T, Hust M (2012) Generating recombinant antibodies for research diagnostics and therapy using phage display. *Curr Biotechnol* 1:33–41
 55. Hoogenboom HR (2005) Selecting and screening recombinant antibody libraries. *Nat Biotechnol* 23:1105–1116
 56. Nieri P, Donadio E, Rossi S, Adinolfi B, Podestà A (2009) Antibodies for therapeutic uses and the evolution of biotechniques. *Curr Med Chem* 16:753–779
 57. Thie H, Meyer T, Schirrmann T, Hust M, Dübel S (2008) Phage display derived therapeutic antibodies. *Curr Pharm Biotechnol* 9:439–446
 58. Hust M, Dübel S (2005) Phage display vectors for the in vitro generation of human antibody fragments. *Methods Mol Biol* 295:71–96
 59. Qi H, Lu H, Qiu H-J, Petrenko V, Liu A (2012) Phagemid vectors for phage display: properties, characteristics and construction. *J Mol Biol* 417:129–143
 60. Shirai H, Kidera A, Nakamura H (1999) H3-rules: identification of CDR-H3 structures in antibodies. *FEBS Lett* 455:188–197
 61. Johansen LK, Albrechtsen B, Andersen HW, Engberg J (1995) pFab60: a new, efficient vector for expression of antibody Fab fragments displayed on phage. *Protein Eng* 8:1063–1067
 62. Little M, Welschhof M, Braunagel M, Hermes I, Christ C, Keller A, Rohrbach P, Kürschner T, Schmidt S, Kleist C, Terness P (1999) Generation of a large complex antibody library from multiple donors. *J Immunol Methods* 231:3–9
 63. Welschhof M, Terness P, Kipriyanov SM, Stanescu D, Breitling F, Dörsam H, Dübel S, Little M, Opelz G (1997) The antigen-binding domain of a human IgG-anti-F(ab')₂ autoantibody. *Proc Natl Acad Sci USA* 94:1902–1907
 64. de Haard HJ, van Neer N, Reurs A, Hufton SE, Roovers RC, Henderikx P, de Bruijne AP, Arends JW, Hoogenboom HR (1999) A large non-immunized human Fab fragment phage library that permits rapid isolation and kinetic analysis of high affinity antibodies. *J Biol Chem* 274:18218–18230
 65. McCafferty J, Fitzgerald KJ, Earnshaw J, Chiswell DJ, Link J, Smith R, Kenten J (1994) Selection and rapid purification of murine antibody fragments that bind a transition-state analog by phage display. *Appl Biochem Biotechnol* 47:157–171, discussion 171–3
 66. Vaughan TJ, Williams AJ, Pritchard K, Osbourn JK, Pope AR, Earnshaw JC, McCafferty J, Hodits RA, Wilton J, Johnson KS (1996) Human antibodies with subnanomolar affinities isolated from a large non-immunized phage display library. *Nat Biotechnol* 14:309–314
 67. Akamatsu Y, Cole MS, Tso JY, Tsurushita N (1993) Construction of a human Ig combinatorial library from genomic V segments and synthetic CDR3 fragments. *J Immunol* 151:4651–4659
 68. Hoogenboom HR, Winter G (1992) By-passing immunisation. Human antibodies from synthetic repertoires of germline VH gene segments rearranged in vitro. *J Mol Biol* 227:381–388
 69. Nissim A, Hoogenboom HR, Tomlinson IM, Flynn G, Midgley C, Lane D, Winter G (1994) Antibody fragments from a “single pot” phage display library as immunochemical reagents. *EMBO J* 13:692–698
 70. Barbas CF, Bain JD, Hoekstra DM, Lerner RA (1992) Semisynthetic combinatorial antibody libraries: a chemical solution to the diversity problem. *Proc Natl Acad Sci USA* 89:4457–4461
 71. Desiderio A, Franconi R, Lopez M, Villani ME, Viti F, Chiaraluce R, Consalvi V, Neri D, Benvenuto E (2001) A semi-synthetic repertoire of intrinsically stable antibody fragments derived from a single-framework scaffold. *J Mol Biol* 310:603–615
 72. Jirholt P, Ohlin M, Borrebaeck CA, Söderlind E (1998) Exploiting sequence space: shuffling in vivo formed complementarity determining regions into a master framework. *Gene* 215:471–476
 73. Söderlind E, Strandberg L, Jirholt P, Kobayashi N, Alexeiva V, Aberg AM, Nilsson A, Jansson B, Ohlin M, Wingren C, Danielsson L, Carlsson R, Borrebaeck CA (2000) Recombining germline-derived CDR sequences for creating diverse single-framework antibody libraries. *Nat Biotechnol* 18:852–856
 74. Knappik A, Ge L, Honegger A, Pack P, Fischer M, Wellnhöfer G, Hoess A, Wölle J, Plückthun A, Virnekäs B (2000) Fully synthetic human combinatorial antibody libraries (HuCAL) based on modular consensus frameworks and CDRs randomized with trinucleotides. *J Mol Biol* 296:57–86
 75. Parmley SF, Smith GP (1988) Antibody-selectable filamentous fd phage vectors: affinity purification of target genes. *Gene* 73:305–318
 76. Hawlisch H, Müller M, Frank R, Bautsch W, Klos A, Köhl J (2001) Site-specific anti-C3a receptor single-chain antibodies selected by

- differential panning on cellulose sheets. *Anal Biochem* 293:142–145
77. Moghaddam A, Borgen T, Stacy J, Kausmally L, Simonsen B, Marvik OJ, Brekke OH, Braunagel M (2003) Identification of scFv antibody fragments that specifically recognise the heroin metabolite 6-monoacetylmorphine but not morphine. *J Immunol Methods* 280:139–155
 78. Hust M, Maiss E, Jacobsen H-J, Reinard T (2002) The production of a genus-specific recombinant antibody (scFv) using a recombinant potyvirus protease. *J Virol Methods* 106:225–233
 79. Schirrmann T, Hust M (2010) Construction of human antibody gene libraries and selection of antibodies by phage display. *Methods Mol Biol* 651:177–209
 80. Goffinet M, Chinestra P, Lajoie-Mazenc I, Medale-Giamarchi C, Favre G, Faye J-C (2008) Identification of a GTP-bound Rho specific scFv molecular sensor by phage display selection. *BMC Biotechnol* 8:34
 81. Lillo AM, Ayriss JE, Shou Y, Graves SW, Bradbury ARM (2011) Development of phage-based single chain Fv antibody reagents for detection of *Yersinia pestis*. *PLoS One* 6:e27756
 82. Hust M, Jostock T, Menzel C, Voedisch B, Mohr A, Brenneis M, Kirsch MI, Meier D, Dübel S (2007) Single chain Fab (scFab) fragment. *BMC Biotechnol* 7:14
 83. Rondot S, Koch J, Breitling F, Dübel S (2001) A helper phage to improve single-chain antibody presentation in phage display. *Nat Biotechnol* 19:75–78
 84. Soltes G, Hust M, Ng KKY, Bansal A, Field J, Stewart DIH, Dübel S, Cha S, Wiersma EJ (2007) On the influence of vector design on antibody phage display. *J Biotechnol* 127:626–637
 85. Kirsch M, Hülseweh B, Nacke C, Rülker T, Schirrmann T, Marschall H-J, Hust M, Dübel S (2008) Development of human antibody fragments using antibody phage display for the detection and diagnosis of Venezuelan equine encephalitis virus (VEEV). *BMC Biotechnol* 8:66
 86. Goletz S, Christensen PA, Kristensen P, Blohm D, Tomlinson I, Winter G, Karsten U (2002) Selection of large diversities of antiidiotypic antibody fragments by phage display. *J Mol Biol* 315:1087–1097
 87. Finnern R, Pedrollo E, Fisch I, Wieslander J, Marks JD, Lockwood CM, Ouwehand WH (1997) Human autoimmune anti-proteinase 3 scFv from a phage display library. *Clin Exp Immunol* 107:269–281
 88. Mersmann M, Schmidt A, Tesar M, Schöneberg A, Welschof M, Kipriyanov S, Terness P, Little M, Pfizenmaier K, Moosmayer D (1998) Monitoring of scFv selected by phage display using detection of scFv-pIII fusion proteins in a microtiter scale assay. *J Immunol Methods* 220:51–58
 89. Hust M, Steinwand M, Al-Halabi L, Helmsing S, Schirrmann T, Dübel S (2009) Improved microtiter plate production of single chain Fv fragments in *Escherichia coli*. *N Biotechnol* 25:424–428

Antigen-Specific Human Monoclonal Antibodies from Transgenic Mice

Susana Magadán Mompó and África González-Fernández

Abstract

Due to the difficulties found when generating fully human monoclonal antibodies (mAbs) by the traditional method, several efforts have attempted to overcome these problems, with varying levels of success. One approach has been the development of transgenic mice carrying immunoglobulin (Ig) genes in germ line configuration. The engineered mouse genome can undergo productive rearrangement in the B cell population, with the generation of mouse B lymphocytes expressing human Ig (hIg) chains. To avoid the expression of mouse heavy or light chains, the endogenous mouse Ig (mIg) loci must be silenced by gene-targeting techniques. Subsequently, to obtain antigen-specific mAbs, conventional immunization protocols can be followed and the mAb technique used (fusion of activated B cells with mouse myeloma cells, screening, cloning, freezing, and testing) with these animals expressing human Ig genes. This chapter describes the type of transgenic knockout mice generated for various research groups, provides examples of human mAbs developed by research groups and companies, and includes protocols of immunization, generation, production, and purification of human mAbs from such mice. In addition, it also addresses the problems detected, and includes some of the methods that can be used to analyze functional activities with human mAbs.

Key words Human monoclonal antibodies, Transgenic mice, Immunoglobulin transgenes, Knockout mice, Transloci bearing human Ig genes, Gene targeting, YAC-based human Ig transloci

1 Introduction

Antibodies are one of the main defense mechanisms of vertebrate animals, able to neutralize and destroy pathogens with the help of other components of the immune system. Until the development of monoclonal antibodies (mAbs) in 1975 by Köhler and Milstein [1], antisera containing a mixture of several types of antibodies (polyclonal antibodies) were used for diagnostic or therapeutic purposes. The first evidence that mAbs could have therapeutic potential came in the early 1980s, when a patient (Philip Karr) suffering from a lymphoma showed a clear response to treatment with mouse antibodies directed against the Ig idiotype in his tumoral cells [2]. Soon after, several pharmaceutical companies started to

become involved in the production of mAbs directed against different human surface molecules, developing antibodies for the treatment of cancer and autoimmune diseases, as well as against transplant rejection processes. From the first clinical trials, it became clear that murine antibodies could be immunogenic [3]. After several immunizations, patients developed hypersensitivity reactions and anti-murine antibodies were produced (HAMA: human anti-mouse antibodies or HARA: human anti-rat antibodies), thereby reducing the potential of antibodies in human therapy.

Although the use of *fully human mAbs* could have several advantages compared with the use of murine antibodies (lower immunogenicity, better interaction with human effector systems such as opsonization, binding to Fc receptors, or the same glycosylation pattern), the production of human mAbs has resulted to be more tedious than first thought. There have been several attempts to produce fully human mAbs, which are very well addressed in other chapters of this book. The use of viral infection, fusion with human myeloma cells, and heterohybridomas with mouse myeloma fused to human B cells are just three examples of approaches to produce the tumoral transformation of B cells. The low yields of antibody production, the absence of a stable human myeloma cell line, the instability of the heteromyelomas produced, and the technical problems found during the fusions all led to the search for new alternative methods for obtaining human antibodies in large quantities.

One of these alternatives was the *genetic modification* of murine antibodies. The genetic structure of Igs with discrete gene domains made their manipulation relatively easy by changing murine sequences to human ones. Chimerization, humanization, CDR grafting, and chain shuffling were the methods used to decrease the antigenicity of the murine antibodies [4], while trying to maintain the affinity and specificity of the original antibodies. Indeed, several chimeric or humanized antibodies have already been approved by the Food and Drug Administration (FDA) of the United States and by the European Medical Agency (EMA) [5, 6]. However, immune responses to chimeric or humanized antibodies have also been observed in patients, especially in those receiving mAbs for long periods of time due to their chronic processes [7], which reinforced the need to go one step further and obtain fully human antibodies.

The use of *phage libraries carrying human Ig genes* was one of the techniques that allowed the production of fully human mAbs [8]. The cloning of human Ig coding regions in phage genes (single chain Fv fragments, scFv) allowed the production of phage libraries with different Ig specificities. In this context, the selection of the antibody with the desired specificity and affinity is carried out by the sequential enrichment of engineered phages against a

specific antigen. This method has numerous advantages, including that no animal immunization is required, any antigen can be used (even when highly toxic) and it has a low cost. Initially, there were some problems when using phage libraries carrying human Ig sequences, among others: low affinity; absence of glycosylation in the antibody fragments; and immunogenicity to some random combinations of heavy and light chains that are not normally found *in vivo*. Moreover, without the Fc regions, the scFVs do not fulfill certain important effector functions such as antibody dependent cytotoxicity, complement activation or induction of phagocytosis, which are essential for some therapies. Although most phage libraries only carry variable Ig regions (single chain Fv from heavy and light chains), using adequate expression systems (such as the cloning of coding regions for heavy and light chains in mammalian cells), it was possible to produce fully human antibodies, overcoming the problems mentioned above [9, 10].

New expression vectors, the identification of adequate places for the gene integration of the genome and the development of new methods to grow cells have turned the cell culture system into the most suitable approach for producing high yields of human antibodies. The most frequently used cell lines are those of lymphoid origin, like mouse myelomas (NSO or SP2/0) that are easy to transfect and have a high secretory level, and non-lymphoid cells, such as CHO (from Chinese hamster ovary) or Hela (from human cervical cancer). Differences in the pattern of Ig glycosylation are crucial elements for the immune response that can be generated against such engineered human antibodies. It is known that around 1 % of the IgG molecules present in human serum are directed against the epitope $\alpha 1,3\text{-Gal } \beta 1,4\text{-GlcNAc}$, probably due to their presence in enteric bacteria [11]. Although murine cells can add a terminal $\alpha 1,3$ galactose to the antibodies, making them highly immunogenic [12], human, primate, and CHO cells have lost the enzyme responsible for this type of glycosylation [13]. Some examples of fully human mAbs using phage display are adalimumab (anti-TNF α) against rheumatoid arthritis, Crohn's disease, or psoriasis, and ABT-874 against p40 (neutralizing both IL-12 and IL-23) [5, 9].

The introduction of human hematopoietic cells into *severe combined immunodeficient (SCID) mice* is another approach to producing human antibodies. These mice receive human hematopoietic cells (either into fetal tissue or peripheral blood cells) [14, 15] and are immunized to generate fully human mAbs. To produce *Trimera mice*, conventional animals are totally irradiated to destroy their bone marrow. These mice then receive a bone marrow transplant, obtained from SCID mice, and subsequently human hematopoietic tissue. Following antigen immunization, hybridomas secreting antigen specific human antibodies can be generated from such treated mice [16]. However, maintenance of

these animals is not easy, as it requires special installations and sterile conditions, while the animals can suffer from agammaglobulinemia, severe lymphopenia, and infections.

In the 1980s, thanks to the development of molecular biology techniques and to the advances in the manipulation of embryonic cells, in microinjections and in the use of several vectors, different models were generated of *transgenic mice carrying Ig genes* (initially of mouse or rat origin) [17]. The first transgenic mice carried a rearranged mouse Ig transgene, but the expression of the transgene was very poor. New attempts, including rearranged mouse or rat Ig genes entirely under their own control regions, allowed the correct expression of the transgenes. This opened up the possibility for other research groups to introduce more Ig genes into the mouse germ line, either in rearranged or in un-rearranged form. The generation of several transgenic mice carrying different types of Ig transgenes has provided, and continues to provide, invaluable information about phenomena such as, among others [17], the following: control of expression of Ig genes; allelic and isotypic exclusion; the rearrangement and somatic hypermutation processes [18–20]; description of regulatory elements; identification of hotspots and cold mutations; and the development of new techniques, such as the use of Peyer's patches B cells to analyze mutations [21–23].

After this success, in the 1990s, some researchers tried to engineer mouse strains by the introduction of human immunoglobulin genes codifying for heavy and light chains into the mouse germ line. These *transgenic mice* carrying un-rearranged sequences of human immunoglobulin genes could potentially now produce B cells expressing human Igs. This was possible because human sequences were shown to be compatible with the mouse factors involved in the rearrangement of Ig genes, class switch and affinity maturation. The animals could secrete fully human antibodies in their serum with a diverse repertoire, be immunized in a conventional way, and undergo similar processes of selection and maturation to mouse B cells. These strains could now be used to generate mouse hybridomas following the classical approach of producing a large panel of fully human mAbs with high affinity and specificity, against a large repertoire of antigens (pathogens, proteins or even human tumoral cells) [24–26].

As reviewed by Brüggemann [27], transgenic mice were developed using vectors containing different amounts of foreign DNA: miniloci; bacteriophage P1 clones; bacterial chromosomes (BACs); yeast chromosomes (YACs); or human chromosome fragments (HCF) (Table 1). One important question was how many genes (especially of variable regions) should be integrated, following the hypothesis that a larger number of genes could generate a wider repertoire of antibodies. As miniloci or plasmids only integrate low amounts of foreign DNA, artificial chromosomes were

Table 1
Summary of some examples of genetic constructions used to generate transgenic mice able to produce human Igs

Loci	Tg (#)	Size (kb)	Functional V genes	References
<i>IgH*</i>				
HuIgH	μ	25	2	[24, 28]
HuIgH ^{cos}	μ	100	2	[24, 51]
HC1	μ γ1	61	1	[52]
HC2	μ γ1	80	4	[53]
<i>Igk*</i>				
KC1	κ	24	1	[52]
Kco4	κ	43	4	[53]
<i>IgH**</i>				
J1.3	μ	85	2	[54, 55]
HuIgH	μ	240	5	[33]
YH1	μ	220	5	[56]
YH2	μ γ2	1020	≈40	[57]
hCF(SC20)	μγ(1–4)	1500	≈40	[58]
<i>Loci k**</i>				
Yk1	κ	170	2	[33]
HuIgkYAC	κ	300	2	[59]
HucosIgkYAC	κ	1300	≈80	[51]
KCo5	κ	450	≈26	[60]
Yk2	κ	800	≈25	[56]
hCF(2-W23)	κ	3000	≈35	[58]
<i>Loci Ig λ**</i>				
Yλ	λ	380	15	[61]

*Genetic constructions using cosmids (COS)

**Genetic constructions using yeast artificial chromosomes (YAC)

used instead to include more genes, containing either heavy or light chain genes. The amount of DNA incorporated, the number of different V segments, the presence or absence of regulatory elements in those transgenes, or the integration in the genome, all differed from one mouse to another, leading to important differences between the types of transgenic mice [27, 28].

To avoid mouse antibody production, gene targeting on embryonic stem cells was necessary to remove endogenous Ig genes. A mouse unable to secrete μ heavy chain was the pioneer [29] (Table 2) and was, subsequently, used by many groups. Although the normal development of B cells was impaired in these mice without the C_μ membrane exon, the production of endogenous mouse IgA or IgG was observed in these mice. This meant that the generation of new knockout mice lacking J heavy genes was required to avoid gene rearrangement [30]. Mice homozygous

for the deletion of J heavy genes presented a complete interruption in B cell development (no mature B cells were found in bone marrow or in the periphery) and an impaired antibody production. However, the introduction of a complex human immunoglobulin Yeast Artificial Chromosome (YAC) into these mice led to the recovery of the B cell population [31].

Several knockout mice for κ chains were also generated in the 1990s (Table 2). Although some hybrid antibodies (human heavy with mouse λ chains) were observed in some mice, the inactivation of the λ locus was shown to be not as crucial as that of the κ locus, because over 90 % of the mouse antibodies used the κ chain [32]. Recently, a λ knockout mouse has been developed and patented by Drs Brüggemann and Zou, X (Table 2), and it can be crossed with other transgenic and knockout mice.

The development of the “final” transgenic mouse producing fully human Igs in the absence of mouse endogenous antibodies is a very complex process, which has required and continues to require, the effort and time of several research groups and companies (Table 3). Once the transgenic and knockout mice are developed, several crossings of individual mice are necessary to obtain animals with distinct features. Figure 1 shows an example of obtaining a mouse carrying six features: a mouse carrying a human heavy transgene (HuIgH+) is crossed with a mouse lacking endogenous heavy genes (ko moIgH-/-); a human transgenic κ mouse (HuIg κ +) is crossed with a knockout mouse for mouse κ (ko moIg κ -/-); a mouse carrying a human λ (HuIg λ +) transgene, is crossed with a mouse knockout for endogenous λ genes (Ko moko λ -/-). Finally, all these resulting mice must then be crossed to generate a mouse with six features: HuIgH+, HuIg κ +, HuIg λ +, moIgH (-/-), moIgk (-/-), moIg λ (-/-), which is able to produce the human Ig chains included in the transgenes, without the presence of endogenous mouse antibodies (Fig. 1).

The production of human antibodies using several types of transgenic mice has mainly been carried out by companies and by a small number of research groups (Table 3). The extreme difficulty in generating these mice, their requirements in terms of crossing and special maintenance and, more importantly, the patents protecting most of these mice have restricted the use of this source of human antibodies in research laboratories. Moreover, several problems have been found in certain mice, including a low number of peripheral B cells, the expression of endogenous mouse chains (by aberrant rearrangements or splicing processes), and a lower efficiency in the production of Igs. In recent years, several biotechnology companies (Abgenix, Medarex, Kyowa Kirin company, Kymab, or Crescendo Biologics) have been dedicating particular attention and efforts to these mice, for their use in the generation of therapeutic fully human monoclonal antibodies (Table 3).

Some research groups [27, 28, 33, 34], including our group [35–39], have generated hybridomas from transgenic mice carrying

Table 2
Summary of knockout mice for Ig genes, indicating the genes inactivated and effects on animals

Inactivation	Gene affected	Effects	References
<i>Heavy</i>			
μ MT (-/-)	Ko: mouse Ig μ membrane exon. Stop codon and neo cassette intro the membrane exon of the IgM constant region	Absence of B cells	[29]
JH (-/-)	Ko: mouse JH genes	No detectable mouse IgM or IgG antibodies	[30] GenPharm International. Taconic
IgD (-/-)	Ko: one exon of the constant region (C δ 3) and exons for the secretory and membrane-spanning part of the protein (δ S, δ X, δ M1, and δ M2) (inactivated by insertion of a neomycin resistance gene)	No detectable mouse IgD antibodies	[62]
IgE (-/-)	ko: homozygous null mutation of the C ϵ gene	No detectable mouse IgE antibodies	[63]
JH (-/-)	Ko: First exon Joining heavy chain locus	Mouse IgM levels reduced Mouse IgA levels elevated Mouse IgG marginal reduction	[64]
<i>Kappa</i>			
κ (-/-)	Ko: C κ (inactivated by insertion of a neomycin resistance gene)	Increased mouse λ + B cells κ rearrangements not completely abolished	[65]
κ (-/-)	Ko: κ (intron enhancer, inactivated by insertion of a neomycin resistance gene)	Increased mouse λ + B cells κ rearrangements completely blocked	[66]
κ (+/-) κ (-/-)	Ko: J κ , κ intron enhancer and C κ exon with a neo cassette	Tenfold more λ + B cells	[67]
κ (-/-)	Ko: C κ by gene targeting	Four main λ are expressed (λ 1, 2(V2), 2(Vx), 3)	[68]
κ (-/-)	Ko: Neo cassette in the C κ	Affected serum titers after secondary immunization	[69]
<i>Lambda</i>			
λ (-/-)	Ko: λ locus deleted using LoxP constructs	No λ expression	Bruggemann, M.; Zou, X. Patent number: 20110093961

Ko knockout

Table 3
Examples of mice carrying human Ig genes obtained by crossing

Crossing	Regions affected	Effects	Company/Ref
λ (-/-) \times κ (-/-)	Ko: mouse λ and κ chain loci	No production of light chains	[32]
Double inactivated (DI) strain	Ko: mouse JH and Ck regions	Pro-B but no mature B cells	Abgenix. US patent application Ser. No. 07/466,008, filed Jan. 12, 1990
J (-/-) \times k (-/-)	Ko: mouse J segment genes (heavy and light chains)	No expression of mouse heavy and kappa chains	Abgenix. Patent number: 6673986. Filing date: Mar 15, 1993
Double-Tc/KO mice	Ko: mouse C μ 2, C μ 3-C μ 4, and M μ 1-M μ 2 exons replaced by a neo cassette	No mouse IgM or IgG on serum No kappa expression	[70]
Double-Tc/KO(λ 1 low/low) strain	Ko: Mouse Ck exon replaced by a neo cassette Animal crossed with CD1 animals homozygous λ 1 low	Low mouse lambda expression	
BAB4	Tg: human Heavy, human kappa Ko: mouse heavy, mouse kappa	No mouse IgM on serum No kappa expression	[40]
BAB5	Tg: human Heavy, kappa, lambda Ko: mouse heavy, kappa	No mouse IgM on serum No kappa expression	[40]
Medarex's HuMAb Mouse (TM)	Tg: human heavy, kappa Ko: mouse heavy, kappa	Human Igs, Mouse antibody producing genes inactivated	Medarex

KHK's TC Mouse™	Tg: two human chromosome fragments containing the Ig heavy chain locus and the human kappa locus (unstable)	Human Igs	Kyowa Kirin company
KM Mouse™	Crossing KHK's TC mouse with Medarex's HuMAB Mouse Tg Tg: human heavy, human kappa Ko: mouse heavy, mouse kappa	Majority of human Ig subclasses (IgG1, 2, 3, 4, IgA)	Medarex-Kyowa Kirin companies
KM Mouse™ × λHAC KM Mouse™	Tg: human lambda light chain	Human lambda expression	Kyowa Kirin company
XenoMouse I Strain	Tg: Human IgMκ antibodies Ko: mouse JH and Ck regions	Reduced number of B cells	[33]
XenoMouse IIa Strain:	Similar to Xenomouse I, but additional γ2 and mouse 3'enhancer on cis	Normal B cells	Abgenix
L6 strain	Tg: human heavy and kappa light chains Ko: double inactivated mouse background (L6)	Normal B cells	Abgenix
Xenomouse strain	Tg: Human V, D, Cμ, Cδ, Cγ1, γ2, γ3, α, ε Tg: human Vk, Jk, Ck Ko: mouse H (J segment genes), Ck deleted	Human Igs	Abgenix
Kymouse™	Human Heavy, κ and λ loci Kymouse HK™ (Ig H and Ig κ) Kymouse HL™ (Ig H and Ig λ) Kymouse HKL™ (Ig H, Ig κ and Ig λ) Kymouse KO (Knockout mouse Ig κ)	Human Igs	Kymab
Crescendo transgenic platform	Engineered human Ig H analogous to H chain antibodies produced naturally in llamas	Human Igs with only heavy chains	Crescendo Biologics

Ig transgenic, *ko* knockout, *Ig* immunoglobulin, *Ref* references

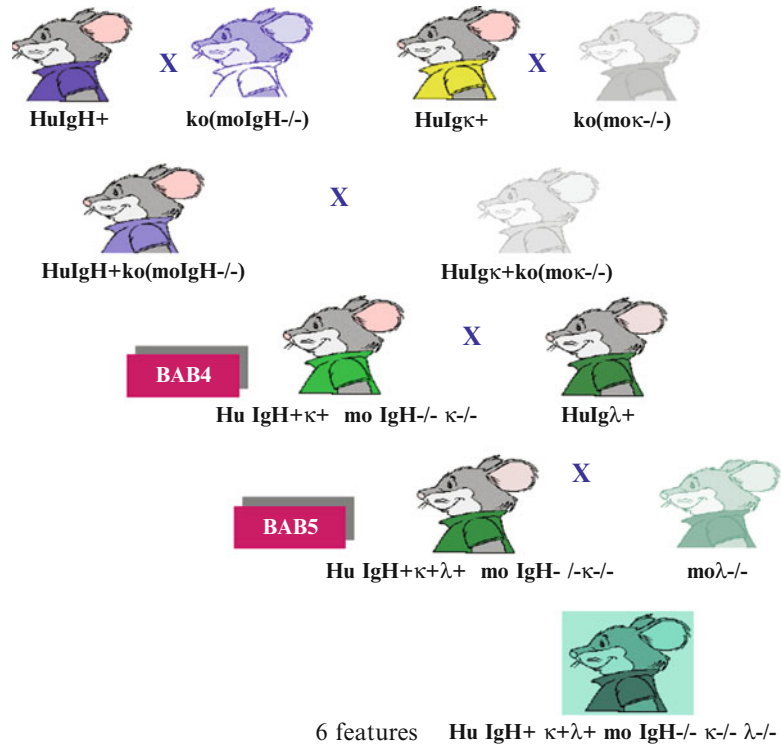

Fig. 1 Examples of mouse crosses to generate transgenic mice carrying four features (like BAB4 mice), five features (like BAB5 mice) or six features. *HuIgH+*, *HuIgκ+* and *HuIgλ+*: transgenic mouse carrying human heavy, kappa and lambda genes. *ko* (*moIgH-/-*, *moIgκ-/-*, *moIgλ-/-*): knockout for mouse heavy, kappa and lambda genes

human Ig genes. In our case, two different mouse strains (BAB 4 and BAB 5) developed by Dr Brüggemann [40] were used. The BAB4 strain (referred to as four-feature mice) carries human IgM,κ transgenes in an inactivated background of mouse heavy and κ chain genes, while the BAB5 strain (referred to as five-feature mice) carries an additional human λ transgene. Both strains produce fully human IgM antibodies [35] with either human κ or λ chains; few antibodies carrying endogenous mouse lambda were found, even though the animals did not have the λ locus inactivated. Several mouse hybridomas secreting human IgM antibodies have been produced from these animals [35–38]. We have shown that the rearrangement of only one human IGVH gene was sufficient to generate a wide repertoire of antigen-specific antibody responses in these mice [37]. Other authors have indicated that a reduced V repertoire has important consequences on T-independent antigen responses [41].

We were able to generate human monoclonal antibodies with several specificities from BAB4 and BAB5 mice, such as those directed against human CD69 [36], human class II MHC molecules [38] or human leucocytes [39], which could potentially be used in human therapy. Hybridomas secreting human Ig antibodies

have also been developed by other groups, generating mAbs directed against tetanus toxin, IgE, progesterone, human CD4, EGFR, IL-8, I-selectin, GCSF, etc. [27], or even more recently against the HIV gp140 antigen [34].

The following companies have engineered mice to produce fully human antibodies in vivo: *Bristol-Myers Squibb* (<http://www.bms.com>) with the *UltiMab platform* developed by *Medarex*; *Amgen*, who acquired *Abgenix* with its *Xenomouse technology* (<http://www.amgen.com>); *Kirin Brewery Company* with its *TransChromo mice* (mice carrying chromosomal fragments bearing the intact human Ig loci); and *Regeneron*, with its *VelocImmune* mice.

The *Medarex-UltiMab platform* consists of a transgenic mouse strain capable of producing multiple high-affinity human sequence IgG κ mAbs. The light-chain transgene is partly derived from a yeast artificial chromosome encompassing nearly half of the human V κ region, while the heavy-chain transgene encodes for human μ and γ 1 constant regions. Over 30 antibody compounds have been derived via the UltiMabTechnology, some have already been approved while others are undergoing different clinical trials (Table 4).

The *TransChromo mice* (TC MouseTM) from the *Kirin Brewery Company* incorporate the entire human immunoglobulin (hIg) loci, expressing a fully diverse repertoire of hIgs, including all the subclasses of IgGs (IgG1-G4). Immunization of the TC Mouse with human antigens led to obtaining hybridoma clones expressing fully human antibodies specific for the target human antigen. However, due to the instability of the Igkappa locus-bearing HCF2, the efficiency of hybridoma production was less than one-tenth of that observed in normal mice [42]. This problem was solved by crossing these mice with the Medarex-YAC transgenic mice, generating the *KM Mouse*, which performed as well as normal mice regarding efficiency of hybridoma production.

The company *Abgenix* developed *XenoMouse* strains including most of the variable region repertoire in germ line-configured human IgH and Igk loci, the genes for C μ , C δ and either C γ 1 or C γ 2 or C γ 4, as well as the cis elements required for their function. The IgH and Igk transgenes were bred onto a genetic background deficient in the production of murine Ig, and the mice developed a diverse primary immune repertoire similar to that from adult humans [43]. The immunization of these mice, followed by conventional hybridoma technology, has allowed the generation of fully human mAbs, such as Panitumumab, Denosumab, and Conatumumab (Table 4).

The *Regeneron* company (<http://www.regeneron.com/velocim>) has developed the *VelocImmune technology*, which allows the generation of fully human antibodies in two steps: (1) Conventional hybridoma cells are generated from transgenic animals carrying the entire human Ig heavy and k light chain variable repertoire. As these animals contain all their mouse constant regions, the obtained hybridomas secrete chimeric mAbs (human-mouse) against the immunizing antigen. (2) The mouse constant

Table 4
Summary of fully human monoclonal antibodies derived from transgenic technology

Antibody	Company ^a	Target	Indication	Approval ^a
Denosumab XGEVA (Prolia [®])	XGEVA, Amgen	RANKL	Postmenopausal osteoporosis	FDA 2010 EMA 2010
Golimumab CNTO148 (Simponi [®])	Centocor Johnson & Johnson Medarex	TNF α	Rheumatoid arthritis, psoriatic arthritis, and ankylosing spondylitis	FDA 2009 EMA 2009
Ipilimumab (MDX-101) (Yervoy [™])	Bristol-Myers Squibb.	CD152 (CTLA-4)	Activator of the immune system: late stage melanoma and other type of tumors	FDA 2011
Ofatumumab (Arzerra HuMax-CD20 [®])	Medarex/Genmab	CD20	Chronic lymphocytic leukemia	FDA 2009 EMA 2010
Panitumumab (ABX-EGF) (Vectibix [™])	Amgen/Abgenix	Epidermal growth factor receptor (EGFR)	Metastatic colorectal carcinoma	FDA 2006 EMA 2007
Ustekinumab CNTO 1275 (Stelara [®])	Centocor Johnson & Johnson Medarex	P40 from IL-12 and IL-23 receptors	Psoriasis, multiple sclerosis	FDA 2009 EMA 2008
<i>On clinical trials</i>				
Conatumumab	Amgen	CD262	Solid tumors	Clinical trials
Ganitumab (AMG 479)	Amgen	IGF-1R	Tumors	Clinical trials
REGN727	Regeneron	inhibitor of PCSK9	Control of LDL cholesterol levels	Clinical trials (phase 2)

REGN668	Regeneron	IL-4R	Allergy processes and immune conditions	Clinical trials (phase II)
REGN421	Regeneron	Dll4	Advanced malignancies	Clinical trials (phase I)
REGN910	Regeneron	ANG2	Oncology	Clinical trials (phase I)
REGN475	Regeneron	nerve growth factor (NGF)	Pain	Clinical trials (phase II)
REGN728, REGN1033, REGN846 and REGN1154	Regeneron	undisclosed	Undisclosed	Clinical trials (phase I)
Salirumab (REGN88)	Regeneron/Sanofi	IL-6 R	Rheumatoid arthritis	Phase III
Tremelimumab	Pfizer	CTLA-4	Melanoma, small cell lung cancer and prostate cancer	Clinical trials
Zalutumumab HuMax-E GFr	GenMab	EGFR	Tumors	Dropped 2011
Zanolimumab HuMax-CD4™	Genmab/Merck Serono	CD4	Cutaneous T-cell lymphoma	Clinical trials

^aObservation: Commercialization by companies and the state of clinical trials can change during time. It has been compiled from various sources. This table contains partial information from Arruebo et al. [5]

region is replaced in those hybrid cells by its human counterpart through genetic engineering and further insertion into mammalian cell lines. Using this technology, the company has developed several antibodies, which are now at different phases of clinical trials, some of them in collaboration with the company Sanofi. The current portfolio of human mAbs on clinical trials derived from transgenic mice (Table 4) or from other types of technologies [5] is very large, indicating the high level of interest in them by the pharmaceutical industry.

Together with new technologies being developed for the generation of human mAbs [44, 45], companies such as *Kymab* (with a new platform called *kymouse*TM) and *Crescendo Biologics* (with its triple knockout mice lacking mouse H, κ , and λ genes) are working in this field, and in the near future it is very possible that many more human mAbs will be approved by the regulatory agencies for several human diseases.

The generation of human mAbs from transgenic mice will now be described in detail. Firstly, the immunization protocols will be presented, followed by the generation of hybridomas, screening of the antibody-secreting hybridomas, and further antibody purification. In addition, the problems detected and the potential functional studies to be performed in vitro and in vivo with the antibodies are included.

2 Materials

Immunization

- *Adjuvants: several adjuvants* can be used, such as Complete and Incomplete Freund's Adjuvants (CFA, IFA) (Sigma), Ribi Adjuvant System (Ribi ImmunoChem Research), and Aluminum Hydroxide (Alum).

Fusion

- *Murine myeloma cell lines* Sp2/0 (ATTC, CRL-1653) or NSO. Other mouse hybridoma fusion partners are listed in the American Type Culture Collection (www.atcc.org).
- *Splenocytes* from immunized transgenic mice carrying human Ig genes.
- *Media:* Roswell Park Memorial Institute (RPMI) or Dulbecco Modified Eagle's Minimal Essential Medium (DMEM), supplemented with 5–20 % fetal calf serum (FCS), 4 mM l-glutamine, 1 mM sodium pyruvate, nonessential amino acids, 50 U penicillin, 50 μ g streptomycin (all from Life Technologies).
- *Hybridoma-grade dimethyl sulfoxide* (DMSO) for cryopreservation (Sigma).
- *Hypoxanthine–Aminopterin–Thymidine (HAT) and hypoxanthine–thymidine (HT)* for hybridoma selection (Sigma).

- *Polyethylene glycol* solution (PEG) 50 % (w/v) (Sigma).
- *4 % Trypan Blue solution*, made with Phosphate buffered saline (PBS) for counting viable cells.

Screening by ELISA or by flow cytometry

- *Buffers: Phosphate-buffered saline (PBS)*; 5.68 g sodium phosphate dibasic (0.01 M), 35.48 g sodium chloride (0.15 M), 2.8 g bovine albumin, 4.0 g sodium azide, complete to 4 L with deionized water, pH to 7.4. *0.1 M Citrate buffer*: prepare two solutions, 0.1 M citric acid and 0.1 M sodium citrate, and combine them to get a pH of 4.3.
- *Secondary antibodies*: goat or rabbit Igs conjugated with enzymes (ELISA) or fluorochromes (flow cytometry) directed against human immunoglobulin heavy and/or light chains.

Immunoglobulin sequencing

- *Total RNA isolation kit* (RNeasy mini kit, Qiagen), reverse transcriptase (SuperScript[®] III RT, Invitrogen).
- *Standard PCR reagents* (Taq polymerase, dNTPs, primers, thermo tubes, agarose, ethidium bromide).
- *Sequencing kit* (BigDye[®] Terminator Cycle Sequencing kit, from Life Technologies).

Antibody purification

- *Protein A, Protein G, Protein L* or other affinity chromatography reagents used to purify mAbs (all from Pierce). There are different commercial pre-packed ready-to-use columns (Pierce, Thermo Scientific, Amersham Biosciences). Slide-A-Lyzer Dialysis Cassettes (Pierce).

Complement activation

- Human serum as source of complement or commercial human complement (Sigma).
- Lyophilized rabbit complement (Sigma).
- Propidium iodide at 20 µg/ml in PBS.

Equipment and laboratory ware

- *Cell culture laboratory including*: laminar flow hood, CO₂ incubator, fridges (−20 and −80°C), liquid nitrogen container, inverted and standard microscopes, 37 °C water bath, refrigerated centrifuges. Sterile pipettes, sterile 24-well and 96-well plates, tissue culture flasks, 15 and 50 ml conical tubes, hemocytometers, sterile scissors and forceps.
- *Equipment for screening tests*: ELISA reader (Envision), Flow Cytometer (Coulter)

- *DNA Sequencing*: PCR-thermocycler (Bio-Rad), sequencer (3130 Genetic Analyzer, Applied Biosystems).

3 Methods

3.1 Immunization

Protocols for mice immunization vary widely according to the antigen used (*see Note 1*). In general, the immunogen is prepared with an adjuvant, and injected several times (2–3 times or more) at regular intervals (after 3–4 weeks). The titer of specific human antibodies in mouse serum should be at least 1/1,000 by ELISA.

3.1.1 Immunogen Preparation

1. When the antigen is a *soluble protein*, Alum can be used as adjuvant.
 - (a) Mix 1 ml of protein (at 1 mg/ml) with 1 ml of a solution 5 % Alum ($\text{KAl}(\text{SO}_4)_2 \cdot 12\text{H}_2\text{O}$) in sterile distilled water.
 - (b) Add NaOH 4 M, drop by drop, to adjust the pH to 6.5. A white precipitate appears. Centrifuge 5 min (at $1,000 \times g$). Discard the supernatant, wash the precipitate in sterile PBS (pH 7.4) and, finally, add PBS to reach the desired concentration.
2. *Intact (tumoral, primary or peripheral blood) cells* are highly immunogenic and do not usually require adjuvants. Nevertheless, our experience with transgenic mice suggests that the use of Freund's adjuvants improves the immune response.
 - (a) Wash the target cells with PBS (pH 7.4) followed by centrifugation. Add PBS and count the cells using Trypan blue in a Neubauer chamber. Prepare 5×10^6 – 1×10^7 cells in 250 μl of sterile PBS.
 - (b) Add an equal volume of Freund's adjuvant and mix thoroughly to get a thick white emulsion. A 1 ml-syringe or a vortex can be used.
3. *Small molecules*, such as peptides or oligosaccharides with low molecular weight, are not usually immunogenic (called *haptens*) and they have to be attached covalently to a carrier (a protein or other compound). The most common carriers are keyhole limpet hemocyanin (KLH), bovine serum albumin (BSA) and ovalbumin (OVA), *see Note 2*.
 - (a) Add 5 mg of peptide to 5 mg of KLH dissolved in 1 ml of 50 mM sodium borate buffer pH 8. Slowly add 1 ml fresh 1 % glutaraldehyde solution with gentle mixing at room temperature (RT). Incubate 2 h at RT rotating gently.
 - (b) Add 0.25 ml of 1 M glycine to bind unreacted glutaraldehyde. Dialyze the reaction mixture overnight at 4 °C against PBS. Prepare the immunogen immediately with Alum or Freund's adjuvant as indicated above.

3.1.2 Animals, Route and Schedule of Inoculation

1. At least five mice (6–12 weeks old) per immunogen should be used. The first immunization is usually by intraperitoneal (ip) inoculation, and it is common to use “complete” adjuvants containing heat-killed bacteria such as *Mycobacterium tuberculosis* in Complete Freund’s Adjuvant (CFA), or *Bordetella pertussis* (10^9 bacteria) in Alum.
2. 3–4 weeks later, the animals are immunized again, but now with incomplete adjuvants (without bacteria) by ip injection. After 10 days, the presence of antigen-specific human antibodies can be detected in serum. Blood can be obtained by mandibular vein puncture or by tail nicking. In both cases, anesthesia is not required. After collection, blood is maintained at 37 °C for 1 h and then at 4 °C for several hours or overnight. After centrifugation at $10,000\times g$ for 10 min, serum is collected, aliquoted and can be maintained at –20 °C for long periods of time.
3. Sera from immunized mice are tested by indirect ELISA (using specific antigen) or by flow cytometry (on target cells) (see later). If the human antibody levels in mice are not sufficient, repeat the ip immunization 2–3 weeks later, until the required levels are reached.
4. Choose the desired animal (more than one can be used per fusion). Three days before fusion, immunize it again by intravenous (iv) injection without adjuvant. The amount of antigen to be injected in the final boost could be around 25 µg of protein /hapten-carrier or 5×10^6 cells resuspended in sterile PBS or in saline.

3.1.3 Serum Titration by ELISA

This protocol is useful when the antigen used for immunization is a soluble protein or a hapten.

1. Dilute the antigen in PBS (pH 7.4) at a final protein concentration of 1–10 µg/ml. Coat the wells of a 96-well plate with 50 µl of the antigen and incubate for 2 h at room temperature, or 4 °C overnight. The incubation time, type of buffer, antigen concentration and the type of plate to be used, may require some optimization.
2. Remove the coating solution and wash the plate three times by filling the wells with 200 µl PBS (with or without 0.01 % Tween 20). Flick the plate over a sink to be sure that all the solution is removed. Dry by blotting onto tissue paper.
3. Block the remaining protein-binding sites by adding 200 µl of blocking buffer (5 % nonfat dry milk, or 5 % FCS, or PBS–2 % Bovine serum albumin (BSA)) per well. Incubate overnight at 4 °C or for at least 2 h at RT. If the plate is to be stored at 4 °C, add sodium azide (0.01 %) and it can be stored for 2 months.
4. Wash the plate twice with PBS–0.01 % Tween 20. Add 50 µl per well of diluted serum in blocking buffer. Test serial

dilutions, for example from 1/250 to 1/10,000. Incubate for 1–2 h at 37 °C, or overnight at 4 °C.

5. Wash the plate three times with PBS–0.01 % Tween 20 in PBS. Add to each well 50 µl of enzyme labeled antibodies directed against human immunoglobulins (HuIgs). Rabbit or goat anti-HuIgs can be used coupled to horseradish peroxidase diluted in PBS–1 % BSA, following the commercial indications, and incubate for 1 h at RT or at 37 °C.
6. Wash the plate three times with PBS–0.01 % Tween 20 in PBS. Add 50 µl/well of ABTS, the horseradish peroxidase substrate, diluted in 0.1 M citrate buffer (pH 4.3) with 1 µl H₂O₂/5 ml buffer (prepare fresh). Incubate at room temperature for 5–20 min, depending on the rate of color development. Stop the reaction by adding 50 µl/well of 0.1 M citric acid with 0.01 % sodium azide, and read the absorbance at 405 nm in an ELISA reader.

3.1.4 Serum Titration by Flow Cytometry

1. Target cells (3×10^5) are incubated at 4 °C for 30–45 min with PBS alone or with serial dilutions of serum (from 1/10 to 1/1,000 or more).
2. Wash twice with PBS by spinning in a microfuge. Stain cells with 50 µl of diluted FITC-rabbit anti-HuIgs Abs at 4 °C for 20 min. Dilutions will depend on the original concentration; follow commercial indications or prepare several dilutions to standardize the immunofluorescence technique (Dako).
3. The stained cells are washed twice with PBS and the cellular fluorescence is measured using a Flow Cytometer. Fluorescence can be analyzed several days later, if the cells are fixed with 0.1 % formaldehyde in PBS at 4 °C.

3.2 Hybridoma Production

1. When human transgenic mice are used as a source of B lymphocytes, the protocol for obtaining hybridomas does not differ significantly from those previously described [46, 47], in which the myeloma and spleen cells are fused using polyethylene glycol (PEG). It is very important to take into account the need to work under sterile conditions when producing and growing hybridomas. Regarding cells, a healthy myeloma cell line is required (we recommend Sp2/0), as well as spleen cells from immunized transgenic mouse (*see Note 3*).
2. A week before cell fusion, the myeloma cell culture should be started in a suitable medium (DMEM or RPMI-1640 with antibiotics and supplemented with 5 % FCS). Cells must have high viability (>95 %) and a density of $\cong 2\text{--}5 \times 10^6$ cells/ml. Cell density can be controlled by periodic monitoring of cell growth, including daily visualization under an inverted micro-

scope and cell counting (using Trypan Blue stain and a Neubauer chamber, or an automatic cell counter).

3. Kill the mouse by cervical dislocation and immerse it in 70 % ethanol. From this step, all work must be carried out under a laminar flow hood in sterile conditions. Tear the superficial skin and make a small incision in the left abdominal side. Take the spleen with a forceps and release it by cutting the mesentery.
4. Prepare a spleen single-cell suspension in culture medium (RPMI) at 4 °C and supplemented with 10 % FCS. Transfer the suspension to a sterile 15 ml tube and harvest by centrifugation ($200 \times g$, 5 min at 4 °C). Add medium without FCS to the pellet and count the cells. To remove the erythrocytes, 0.1 Methylene Violet 6B can be used in 0.21 % citric acid in saline. Keep the tube with the single-cell suspension at 4 °C.
5. The myeloma cells (Sp2/0) are maintained in culture for approximately 1 week and then transferred to different sterile tubes and centrifuged (at $200 \times g$ for 5 min at 4 °C). The pellets are added to a single tube and suspended in culture medium without FCS. Count the cells using Trypan Blue.
6. In a sterile 50 ml conical tube, mix spleen and myeloma cells in a 3:1 (spleen: myeloma) proportion. Fill the tube with serum free medium and spin at $200 \times g$ for 5 min at RT. Discard the supernatant, be sure to eliminate all medium, because it is very important to maintain the concentration of PEG (the fusion agent).
7. Place the tube in a 37 °C water bath (continue working under a laminar flow hood). Add slowly (drop by drop) 1 ml of 37 °C pre-warmed PEG with a glass pipette, and stir the mixture with the pipette. After adding all PEG, continue stirring for 2 min.
8. With the same pipette, add drop by drop a total of 10 ml of serum free pre-warmed medium, and continue stirring. Finally, add drop by drop a total of 12 ml of serum free pre-warmed medium, but now without stirring. Keep the tube at 37 °C in a water bath for 20–30 min.
9. Spin at $200 \times g$ for 5 min and then resuspend the cells in media with 20 % FCS and HAT $1 \times$. Distribute the cells into 24-flat-bottom well plates (four plates are usually used per fusion, each one at a different concentration). The plates have to be kept, with minimal manipulation, in an incubator (at 37 °C with 5 % CO₂ on air) for approximately 1–2 weeks. Monitor the clone growth under an inverted microscope.

3.3 Selection of Cell Colonies

If the fusion is successful, several round colonies appear in each well. When the colony is sufficiently large, it is possible to pick it up under an inverted magnifier and transfer it to an individual well in a 96-well plate.

1. To perform this pre-cloning, examine 24-well plates on an inverted stereo microscope (low magnification) and delimit with a marker the position of the colony. Pick up individual colonies under the inverted stereo microscope using a micropipette (volume 10 μ l) and transfer each colony into an individual well on a previously prepared 96-well plate with 190 μ l of medium (20 % FCS and HAT 1 \times). Check daily, replacing 50 % of the well volume with new media and finally, before cloning, test the antibody production by the screening method.
2. The hybridoma can be adapted to grow in normal medium (without HAT), either before or after cloning. In this process, usually a high proportion of cells do not survive. Strict monitoring of cell growth and viability is required during the adaptation phase. Furthermore, secretion levels should also be assessed, as they can change during adaptation. For 5–7 days, substitute HAT for HT medium, changing 25 % of medium daily. When the cells are stable in HT medium, proceed in the same way, but now changing to normal medium. During these steps, always keep cryopreserved cells as backup. Cells growing in HAT or HT media (at least two vials of each) and in media alone (at least six vials of each) are cryopreserved using the standard procedure in a freshly prepared mixture of 90–95 % FCS and 5–10 % tissue-culture-grade DMSO, with at least 10⁶ viable cells per cryovial. Cells can be maintained in a liquid nitrogen container at –196 °C for long periods of time (*see Note 4*).

3.4 Hybridoma Cloning by Limiting Dilutions

There are several methods for hybridoma cloning, such as the use of agar or cell separation by FACS-sorter, but here the limiting dilution procedure, a simple and quick method, is described.

1. Prior to cloning, count hybridoma cells using a Neubauer chamber and dilute them to the correct concentration. In a flat bottom 96-well plate, add 2000 cells (in 200 μ l) into each well of the first left column. Add 100 μ l medium to the remaining wells, using a multichannel pipette. With the same pipette, perform serial dilutions (1/2) by transferring 100 μ l from the first left column to the second, mix and transfer 100 μ l from the second column to the third and so on, until the last right column (column 12). Fill the wells with medium until a final volume of 200 μ l.
2. Analyze under an inverted microscope if individual cells have been added into the last right columns, and keep the plates in the incubator with 5 % CO₂ at 37 °C. Leave cells growing for 5–7 days, checking daily, and identify with a marker the wells that have a single cell clone.
3. Test the supernatant of these wells, by the previously chosen screening method, to find out if the cells produce the desired antibody. Select 3–5 of the best colonies, expand and freeze them.

4. To have stable cells, every hybridoma requires at least two to three consecutive rounds of recloning. Even highly selected hybridoma cells need to be periodically retested to confirm their specificity and to be recloned, to avoid the overgrowing of hybridomas that have lost their secretion capacity.

3.5 Selection of Positive Clones

One of the most important aspects is the correct choice of a screening assay to determine the presence of specific antibodies in the supernatants. The screening assay should set up well before carrying out the fusion, using the serum of the immunized mice as a source of antigen-specific antibodies, and serum from non-immunized animals as well as medium as negative controls (*see Note 5*).

3.6 Characterization of Human Antibodies

Before introducing the human mAbs obtained in clinical assays or from a commercial supplier, they must be thoroughly characterized. This process includes not only determining the isotype or immunochemical properties of the mAb (*see Note 11*), but also its functional activities (*see Notes 6–9*).

3.6.1 Isotype Determination

Knowledge of the antibody class/subclass and the type of light chain of the antibody structure makes it possible to focus the strategy of purification and to predict its effector functions, such as complement activation, antibody dependent cell cytotoxicity (ADCC) and induction of phagocytosis. There are several available assays for determining the type of immunoglobulin heavy and light chains, although the easiest way is to adapt the screening assay (indirect ELISA or Flow cytometry), including for secondary antibodies directed against specific classes or subclasses of human immunoglobulins. Similarly, it is possible to modify the ELISA for the quantification of the antibody secreted, using a sandwich ELISA in which the plate is coated with rabbit or goat immunoglobulins directed against human antibodies, and with commercial human serum to perform the standard curve (*Beckman*) (*see Note 10*).

3.6.2 DNA Sequence

The primary structure or the amino acid sequence of our human mAb may be deduced from DNA sequencing. Any of the different tools offered by the International IMMuno-GenETics (IMGT) information system® (www.imgt.org) [48] can be used to align the obtained Ig sequences with human germinal sequences, to determine the VDJ and VJ junctions, and to deduce the secondary and tertiary structure, as well as many other analyses.

1. Isolate RNA from 2.5×10^6 hybridoma cells using RNeasy mini kit (Qiagen).
2. Obtain first-strand cDNA by incubating the RNA with human immunoglobulin constant region specific primer (there is a tool on the IMGT Web site, www.imgt.org, to find the specific

primer for each human isotype) and SuperScript® III RT (Life Technologies). The retrotranscription is performed following the manufacturer's instructions.

3. Amplify the rearranged V–J and V–D–J regions by PCR using between 2 and 5 μl of cDNA, in the presence of 2 mM MgCl_2 , 0.1 mM dNTPs, 3 U of Taq polymerase (Bioline), and a total volume of 50 μl . Use 0.25 μM of human VH or VL sense primers, in combination with JH or JL specific antisense primers (visit the IMGT Web site, www.imgt.org, to find the specific primer for each human segments).
4. To obtain a good product, 30 cycles are sufficient: 30 s denaturation (94 °C), 1 min annealing (depends on the primer sequences) and 1 min elongation (72 °C). Before adding the enzyme, the samples are preheated at 94 °C for 2 min, and the final cycle is completed by 10 min elongation at 72 °C. The PCR products are analyzed on a 1.5 % agarose gel and are then ready for sequencing.

3.6.3 Effector Functions: Complement Dependent Cytotoxicity Assay

The mechanisms of action of the mAbs produced should be studied by in vitro and in vivo assays. These assays should include tests to evaluate the ability for complement binding and activation, Fc receptor binding, ADCC and possible cytotoxic effects, even if these properties are not required for the purpose of the particular human mAb being used.

1. The ability of a human mAb to activate complement can be analyzed by Flow cytometry. A total of 5×10^5 target cells are incubated for 30 min at 4 °C with 250 μl medium alone (as negative control), or 250 μl hybridoma supernatant, or an isotype control (a human mAb that does not recognize our target cell).
2. Wash cells twice by spinning and incubate them at 37 °C for 30 min with 250 μl rabbit complement diluted 1:2 in medium (Sigma), human complement (Sigma), or human serum as a source of complement.
3. Add 5 μl of propidium iodide (20 $\mu\text{g}/\text{ml}$) (Sigma) and analyze death cells by Flow cytometry for propidium iodide staining (Fig. 2).

3.7 Purification

Antibody purification is required to concentrate the mAb for in vivo studies or if it is going to be used with fluorochromes, biotin, or enzymes. Human mAbs can be purified by several methods, including ammonium sulfate precipitation, affinity chromatography, gel filtration, or a combination of techniques for obtaining an efficient purification ratio. The choice of the technique depends on the type of antibody, as well as on the initial concentration, and the purity is enhanced if the hybridoma is previously adapted to a reduced or free serum medium.

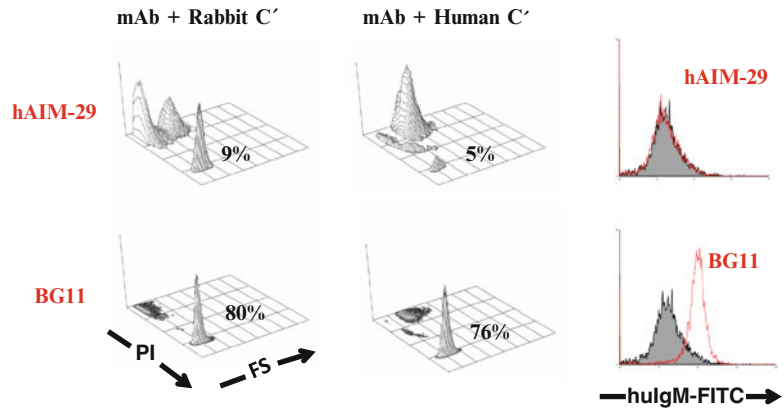

Fig. 2 Complement activation by human mAbs. Target cells (Hmy-22, a tumoral B cell line) were incubated with rabbit or human complement (C') in the presence of hAIM-29 (human IgM mAb anti human CD69) or BG11 (human IgM mAb anti-human B cells). The viability of the cells was tested by the incorporation of propidium iodide (PI) by Flow Cytometry analysis. The *panels* at the extreme *right* of the figure show how target cells were stained with hAIM-29 and BG11 human mAbs, followed by FITC-conjugated anti-human IgM (*red line*)

When the concentration of the antibody is low, for example in hybridoma supernatants, affinity chromatography is the most suitable purification method. The affinity ligands are usually attached to sepharose/agarose gel beads or to membranes, such as proteins with high affinity to the Fc portion of different antibody classes (Protein G/A or specific antibodies directed against some isotypes), or to the light chains (Protein L or specific antibodies directed against light chains), or to the specific antigen recognized by our human mAb. Among these, the most frequently used are protein G or A, as the specific antigens are not always easily obtained in large quantities and at high purity (*see Notes 12–17*).

3.7.1 Purification Using Protein A/G/L

1. Centrifuge the human mAb supernatant at $20,000 \times g$, 4°C and filter through a $0.45\ \mu\text{m}$ filter. Dilute the sample in binding buffer and ensure that the pH is similar to that of the binding buffer (*see Table 5*).
2. Pre-warm the Protein A/G/L-Agarose resin or Sepharose gel, and the diluted sample and buffers at RT (Immunopure Immobilized Protein L, Pierce). Then, add 2–4 ml to a disposable polystyrene column and allow time to ensure proper packing.
3. Equilibrate the column by adding 5–10 volumes of binding buffer (*see Table 5*), allowing the buffer to drain through the column.

Table 5
Protein A/G/L characteristics for human moAb purification

	Human antibody	Binding capacity	Binding buffer pH	Elution buffer pH
Prot A	IgG _{1,2,4} ; IgA; IgM	IgG, strong IgA and IgM, weak	0.1 M phosphate, 0.15 M NaCl pH 7.2–8	0.1 M Glycine–HCl pH 4
Prot G	All IgG	Strong	0.1 M phosphate pH 5–6	0.1 M Glycine–HCl pH 2.5
Prot L	All classes with kappa light chain ^a	Medium	0.1 M phosphate, 0.15 M NaCl pH 7.2–8	0.1 M Glycine–HCl pH 2.5

This is general information. You can find differences that depend on the product. Please read the technical brochure carefully

^aThe protein L binds human kappa chains, which have a V segment belonging to the I, III, or IV family [50]

4. Carefully add the diluted hybridoma supernatant into the column, avoiding that the total amount of Ig applied to the column is higher than 80 % of the total capacity of the column.
5. By saving the flow-through, the non-bound antibody can be recovered and examined by antibody-specific assays.
6. After passing the sample, wash the column with 10–15 volumes of binding buffer, and collect aliquots in which the non-bound antibody can be recovered.
7. Proceed to the release of bound human antibodies using 5–10 ml of elution buffer (*see* Table 5) and collecting 0.5–1 ml aliquots in different tubes, into which had previously been added 100 µl of 1 M phosphate buffer at pH 7.5–9, per each 1 ml of sample collected.
8. The presence of Igs in the collected tubes is monitored by measuring the absorbance in a spectrophotometer at 280 nm. When the absorbance of two or three consecutive fractions is 0, the column can be regenerated.
9. Wash the column with 6 volumes of elution buffer and monitor the presence of protein in the collected fractions. Finally, add 5 ml of water with 0.02 % sodium azide and store the column at 4 °C.
10. The eluted samples should be dialyzed to exchange the buffer; use a buffer that is compatible with the techniques that are going to be applied to a particular human mAb.

3.7.2 Purification Using Other Immobilized Ligand Columns

If the antigen recognized by the particular human mAb being used is available in large quantities or the antibodies being used are directed against HuIgs, the purification can be performed by

affinity chromatography using a column in which these ligands are previously bound.

1. CNBr-activated Sepharose 4B is probably the most widely used matrix, which is commercially available and ready to use.
2. The amount of CNBr-activated Sepharose 4B to be used depends on the ligand quantity. In general, 1 g resin has to be weighed for 3.5 ml of gel, bearing in mind that 1 ml of gel is required per each 5–10 mg of protein to be linked. If the ligand has a very low molecular weight, 2 mg/ml of gel can be used.
3. Before starting the coating with the ligand (antigen or antibody), it should be verified that it is pure and has previously been dialyzed against the coupling buffer (0.1 M NaHCO₃, pH 8.3, 0.5 M NaCl). After dialysis, determine the protein concentration (Bio-Rad Dye method). A final concentration of 2–8 mg/ml is required. If necessary, concentrate the ligand by Amicon or by Centricon filtration.
4. Rehydrate the CNBr-Sepharose gel in 1 mM HCl for 15 min at RT. Do not use a magnetic stirrer. Pour the gel into a bottle top vacuum filter, and wash the gel with 1 mM HCl (200 ml/g resin). Take care that the gel does not dry. Resuspend the gel in 1–2 ml of coupling buffer and mix with the dialyzed ligand in a 15 or 50-ml Falcon tube. Complete with coupling buffer. Rotate the tube for 1–2 h at RT or overnight at 4 °C. To control the coupling, remove supernatant aliquots and measure the optical density at 280 nm.
5. When the coupling is over 90 %, wash the gel with at least five gel volumes of coupling buffer in a bottle top vacuum filter, and proceed to block the remaining active groups by holding the resin for 2 h at RT in 0.1 M Tris-HCl pH 8.
6. Spin out the resin at 400 × *g* for 5 min. Remove the supernatant and wash the resin by centrifugation, alternating three times the following buffers: 0.1 M sodium acetate, 0.5 M NaCl, pH 4 (with acetic acid) and 0.1 M Tris, 0.5 NaCl, pH 8 (with HCl). Finally, the resin is resuspended in PBS, 0.1 % sodium azide, and stored at 4 °C.
7. To purify the human mAb, pour the gel into a polystyrene disposable column and wash with PBS. Apply the sample (previously filtered through a 0.45 μm filter) and proceed to the elution as indicated earlier for the protein A/G/L affinity columns. To assess the most suitable buffer, different elution buffers (with different pH and ionic strength) have to be tested. The presence of Igs can also be monitored by measuring the absorbance at 280 nm.
8. Wash the column with PBS until the elution liquid is at pH 7.4. Store the column in PBS containing 0.1 % azide.

3.8 Production (Medium Scale) with CELLine System

In the past, the production of mAb on a small-medium scale was performed by injecting the hybridoma cells into the peritoneal cavity of a mouse previously primed with pristane. This method prompts ethical questions due to the pain and distress caused in these animals, and many countries have imposed new laws that prohibit or limit the use of animals for expanding hybridomas. Alternatively, different *in vitro* mAb production systems can be used that are based on hollow fiber, suspension growth or double membrane technology [49]. In all cases, a reasonable investment in staff and equipment is required. This section includes a detailed description of our experience using CELLine-CL350 systems distributed by Integra Bioscience for growing hybridomas producing human mAbs. CELLine is a multichamber system based on membrane technology, in which hybridoma cells are maintained in a 15-ml cultivation chamber, and are separated from the nutrient compartment by a semipermeable membrane. Small molecules pass across the membrane, but the antibodies are retained in the cell growth chamber.

1. Culture medium (DMEM or RPMI, 10 % FCS) and nutrient medium (DMEM or RPMI) must be warmed to 37 °C. It is important to wet the semipermeable membrane prior to the inoculation of cells. Add 10 ml of nutrient medium into the nutrient chamber and let the semipermeable membrane equilibrate for at least 5 min. Selective access to the nutrient and cultivation chambers is possible through separate compartments closed by independent caps.
2. Hybridoma cells should have a cellular viability higher than 95 %; around 8×10^6 viable cells in 5 ml culture medium are needed. Open the cell compartment and inoculate the hybridoma cells by inserting the pipette into the silicone cone, trying to avoid bubbles. Close the cell chamber cap.
3. Add 340 ml of nutrient medium into its compartment and close the cap. Place the CELLine into the incubator (5 % CO₂, 37 °C), monitoring hybridoma growth, particularly when using this system for the first time to grow hybridomas. Each cell culture has its own growth characteristics. After 72 h, take an aliquot and test for cell viability and antibody level, using the chosen screening method.
4. 5–7 days later (depending on the hybridoma growth), nutrient media must be discarded and changed, and the antibodies contained in the cell compartment are then recovered. With a 10-ml serological pipette, carefully mix the cells up and down and aspirate the cell suspension, which could be more than 5 ml, due to osmotic flux.
5. Centrifuge the tube for 5 min at $300 \times g$, then take the supernatant and filter it through a 0.22 µm filter. The antibody level

should be tested (by ELISA or flow cytometry) and purified by affinity chromatography, or frozen at -20°C .

6. The cell pellet is resuspended with nutrient media, and 20 % of these cells are mixed with 4 ml of warmed culture medium and inoculated again into the culture chamber. Add 350 ml of fresh nutrient medium into its compartment, and place the CELLLine system into the incubator until the next harvest, approximately every 5–7 days. If the sterility barrier is not breached and the system is handled carefully, the culture can be maintained for several months.

4 Notes

1. As the immune response in transgenic mice may be lower than in conventional mice, repeated immunizations may be required. The use of a good adjuvant to potentiate antigen immunogenicity and analysis of serum 7–15 days after second immunization are both strongly recommended.
2. When haptens are conjugated to carrier proteins, it should be remembered that mice would produce antibodies to the carrier protein, as well as to the hapten. It is important to design a screening test that is useful for discriminating between hapten-specific and carrier-specific antibodies. For example, if KLH is to be used as a carrier, the hapten should also be linked to BSA or OVA by the same coupling method, and this complex should be used to assess anti-hapten antibody titers. Alternatively, special activated microplates can be used for covalent immobilization of peptides, carbohydrates, etc.
3. Numerous mouse myeloma cells have been successfully used for the generation of hybridomas. However, the most widely used cell lines are NSO/1 and Sp2/O, both descendants of MOPC-21. Neither of these cell lines produce endogenous Igs and they can both be selected using HAT (due to their defect in an essential biosynthetic pathway).
4. Stability of the hybridoma can be a problem, which may require continuous cloning–freezing–thawing. Even when growing well, the hybridoma quite frequently stops the production of antibodies. Therefore, a routine screening process (by ELISA, cytometry...) is required. Thawing the hybridoma cells in wells with a layer of mouse spleen or thymic cells can sometimes help.
5. There is frequently a low yield of antibodies using conventional hybridoma media, CELLLine flakes or even ascites. Growing cells at high concentrations can partially resolve this problem.

6. Regarding mAb characterization, the analysis of carbohydrate content must not be forgotten. In general, antibodies are mainly glycosylated within the Fc region and, depending on the expression system, the glycosylation pattern of the mAbs can be modified, principally mannosylation, galactosylation, fucosylation, and sialylation. Knowing the glycosylation level is important, because these residues can affect the effector functions, immunogenicity, and half-life of these therapeutic mAbs in the human body.
7. It is important to verify if the human mAbs show cross-reactivity with other human tissues. This cross-reactivity can be determined using immunohistochemical procedures.
8. In vivo assays with human antibodies in animal models are difficult to perform, due to the immunogenicity reactions. To obtain a situation comparable to a human being, immunosuppressed animals should be used, after previously receiving transplanted human bone marrow cells.
9. Absence of mouse J chain in human Igs. Conventional mouse IgM and IgA incorporate a mouse J chain in their structure, showing characteristic pentameric or dimeric forms, respectively. In the absence of the J chain, monomeric and hexameric forms of IgM should be expected, but not pentameric forms. Using Western blot, we investigated if the mouse J chain was present in an IgM mAb generated from a BAB4 mouse, but it was not detected, indicating that these antibodies could be expressed and secreted in the absence of this protein chain.
10. Problems with some immunological methods. When human antibodies are directed against human cells, a high level of background can be found if using secondary antibodies (labeled antibodies directed to human IgM or to human immunoglobulins) in certain techniques, such as immunofluorescence (flow cytometry, confocal) or histochemistry using human tissues. Previous blocking with human serum will even increase this background. The background is mainly found in human B cells and macrophages, and at the tissue interstices.
11. There is a limited repertoire of antibodies, due to the low number of V genes integrated in the genome. It is not a real problem if the work is undertaken with T-dependent antigens. The use of only one VH gene can be sufficient to generate a variety of antibodies, thanks to other sources of variability (light chains, rearrangement, mutations...) [37].
12. For purification of human antibodies, protein G is the most suitable if human IgG mAbs are to be purified, regardless of the type of subclass (Protein A could be also used, except for human IgG3 subclass). However, in some cases, the pH used for the optimal protein G binding ($\text{pH} \cong 5$) and/or elution ($\text{pH} 2.5$) can alter the antigen binding or the biological activity of the human mAb. In such situations, protein A may be a better

alternative, as pH 7–8 is the optimum for protein A binding, while the elution can be performed at pH 3–6.

13. The main problem comes when the objective is to purify other isotypes (IgM or IgA) because these ligands have shown a low affinity to protein A/G. One option can be protein L. This is an immunoglobulin-binding protein isolated from the bacteria *Peptostreptococcus magnus*, which binds certain kappa variable segments (families I, II, and III) without interfering with antigen binding [50].
14. Different production of heavy and light chains. An overproduction of light chains, but not of the whole antibody, is frequently found. For a correct quantification of antibody production, please test for the presence of the heavy chain. Overproduction of light chains can also affect the purification of antibodies when protein L is used, resulting in a low yield of antibody purification.
15. The half-life of human IgM is very short: 3–4 days. For IgM mAbs, using genetic engineering techniques to change the isotype to IgG is strongly recommended.
16. If transgenic mice carrying human Ig genes are still producing endogenous mouse Igs, the yield of human antibody production can be lower due to competition with the endogenous Igs. The best animal model is the one that does not produce endogenous Igs.
17. Availability. The majority of animal models producing human Igs are not readily available to the scientific community, because of the patents protecting this technology. As mentioned earlier, several companies are now developing fully human mAbs using this technology.

References

1. Köhler G, Milstein C (1975) Continuous cultures of fused cells secreting antibody of predefined specificity. *Nature* 256:495–497
2. Miller RA, Maloney DG, Warnke R, Levy R (1982) Treatment of B-cell lymphoma with monoclonal anti-idiotype antibody. *N Engl J Med* 306:517–522
3. Stas P, Pletinckx J, Gansemans Y, Lasters I (2009) Immunogenicity assessment of antibody therapeutics. In: Melvyn Little ATA (ed) *Recombinant antibodies for immunotherapy*. Cambridge University Press, Cambridge
4. Benny KC Lo (2005) Protein therapeutics: mouse, humanized and human antibodies. In: Walker JM, Rapley R (eds) *Medical methods handbook*. Springer, Berlin, pp 429–446
5. Arruebo M, Vilaboa N, Sáez GB, Lambea J, Tres A, Valladares M, González-Fernández A (2011) Assessment of the evolution of cancer treatment therapies. *Cancers* 3:3279–3330
6. Elbakri A, Nelson PN, Abu Odeh RO (2010) The state of antibody therapy. *Hum Immunol* 71:1243–1250
7. Hansel TT, Kropshofer H, Singer T, Mitchell JA, George AJT (2010) The safety and side effects of monoclonal antibodies. *Nat Rev Drug Discov* 9:325–338
8. Chester KA, Begent RH, Robson L, Keep P, Pedley RB, Boden JA et al (1994) Phage libraries for generation of clinically useful antibodies. *Lancet* 343:455–456
9. Lonberg N (2008) Fully human antibodies from transgenic mouse and phage display platforms. *Curr Opin Immunol* 20:450–459

10. Bratkovic T (2010) Progress in phage display: evolution of the technique and its application. *Cell Mol Life Sci* 67:749–767
11. Hamadeh RM, Jarvis GA, Galili U, Mandrell RE, Zhou P, Griffiss JM (1992) Human natural anti-Gal IgG regulates alternative complement pathway activation on bacterial surfaces. *J Clin Invest* 89:1223–1235
12. Sheeley D, Merrill B, Taylor L (1997) Characterization of monoclonal antibody glycosylation: comparison of expression systems and identification of terminal alpha-linked galactose. *Anal Biochem* 247:102–110
13. Borrebaeck CK, Malmberg AC, Ohlin M (1993) Does endogenous glycosylation prevent the use of mouse monoclonal antibodies as cancer therapeutics? *Immunol Today* 14:477–479
14. Kamel-Reid S, Letarte M, Doedens M, Greaves A, Murdoch B, Grunberger T et al (1991) Bone marrow from children in relapse with pre-B acute lymphoblastic leukemia proliferates and disseminates rapidly in scid mice. *Blood* 78:2973–2981
15. McCune JM (1996) Development and applications of the SCID-hu mouse model. *Semin Immunol* 8:187–196
16. Eren R, Lubin I, Terkieltaub D, Ben-Moshe O, Zauberman A, Uhlmann R et al (1998) Human monoclonal antibodies specific to hepatitis B virus generated in a human/mouse radiation chimera: the Trimer system. *Immunology* 93:154–161
17. Storb U (1987) Transgenic mice with immunoglobulin genes. *Annu Rev Immunol* 5:151–174
18. Brinster RL, Ritchie KA, Hammer RE, O'Brien RL, Arp B, Storb U (1983) Expression of a microinjected immunoglobulin gene in the spleen of transgenic mice. *Nature* 306:332–336
19. Rusconi S, Köhler G (1985) Transcription and expression of a specific pair of rearranged immunoglobulin mu and kappa genes in a transgenic mouse line. *Nature* 314:330–334
20. Grosschedl R, Weaver D, Baltimore D, Costantini F (1984) Introduction of a mu immunoglobulin gene into the mouse germ line: specific expression in lymphoid cells and synthesis of functional antibody. *Cell* 38:647–658
21. González-Fernández A, Milstein C (1993) Analysis of somatic hypermutation in mouse Peyer's patches using immunoglobulin kappa light-chain transgenes. *Proc Natl Acad Sci USA* 90:9862–9866
22. Betz AG, Milstein C, González-Fernández A, Pannell R, Larson T, Neuberger MS (1994) Elements regulating somatic hypermutation of an immunoglobulin kappa gene: critical role for the intron enhancer/matrix attachment region. *Cell* 77:239–248
23. Yélamos J, Klix N, Goyenechea B, Lozano F, Chui Y, González F et al (1995) Targeting of non-Ig sequences in place of the V segment by somatic hypermutation. *Nature* 376:225–229
24. Wagner S, Popov A, Davies S, Xian J, Neuberger M, Brüggemann M (1994) The diversity of antigen-specific monoclonal antibodies from transgenic mice bearing human immunoglobulin gene miniloci. *Eur J Immunol* 24:2672–2681
25. Brüggemann M, Taussig MJ (1997) Production of human antibody repertoires in transgenic mice. *Curr Opin Biotechnol* 8:455–458
26. Jakobovits A, Green LL, Hardy MC, Maynard-Currie CE, Tsuda H, Louie DM et al (1995) Production of antigen-specific human antibodies from mice engineered with human heavy and light chain YACs. *Ann N Y Acad Sci* 764:525–535
27. Brüggemann M (2004) Chapter 34: Human monoclonal antibodies from translocus mice. In: Honjo T, Neuberger MS (eds) *Molecular biology of B cell*, 1st edn. Academic, New York
28. Brüggemann M, Caskey HM, Teale C, Waldmann H, Williams GT, Surani MA et al (1989) A repertoire of monoclonal antibodies with human heavy chains from transgenic mice. *Proc Natl Acad Sci USA* 86:6709–6713
29. Kitamura D, Roes J, Kühn R, Rajewsky K (1991) A B cell-deficient mouse by targeted disruption of the membrane exon of the immunoglobulin mu chain gene. *Nature* 350:423–426
30. Chen J, Trounstein M, Alt FW, Young F, Kurahara C, Loring JF et al (1993) Immunoglobulin gene rearrangement in B cell deficient mice generated by targeted deletion of the JH locus. *Int Immunol* 5:647–656
31. Green LL, Jakobovits A (1998) Regulation of B cell development by variable gene complexity in mice reconstituted with human immunoglobulin yeast artificial chromosomes. *J Exp Med* 188:483–495
32. Zou X, Piper T, Smith J, Allen N, Xian J, Brüggemann M (2003) Block in development at the pre-B-II to immature B cell stage in mice without Ig kappa and Ig lambda light chain. *J Immunol* 170:1354–1361
33. Green LL, Hardy MC, Maynard-Currie CE, Tsuda H, Louie DM, Mendez MJ et al (1994) Antigen-specific human monoclonal antibodies from mice engineered with human Ig heavy and light chain YACs. *Nat Genet* 7:13–21
34. Pruzina S, Williams G, Kaneva G, Davies S, Martín-López A, Brüggemann M et al (2011) Human monoclonal antibodies to HIV-1 gp140 from mice bearing YAC-based human

- immunoglobulin transloci. *Protein Eng Des Sel* 24:791–799
35. Magadán S, Valladares M, Suarez E, Sanjuán I, Molina A, Ayling C et al (2002) Production of antigen-specific human monoclonal antibodies: comparison of mice carrying IgH/kappa or IgH/kappa/lambda transloci. *Biotechniques* 33:680–684
 36. Molina A, Valladares M, Sancho D, Viedma F, Sanjuan I, Madrid F et al (2003) The use of transgenic mice for the production of a human monoclonal antibody specific for human CD69 antigen. *J Immunol Methods* 2823:147–158
 37. Suárez E, Magadán S, Sanjuán I, Valladares M, Molina A, Gambón F et al (2006) Rearrangement of only one human IGHV gene is sufficient to generate a wide repertoire of antigen specific antibody responses in transgenic mice. *Mol Immunol* 43:1827–1835
 38. Díaz B, Sanjuan I, Gambón F, Loureiro C, Magadán S, González-Fernández A (2009) Generation of a human IgM monoclonal antibody directed against HLA class II molecules: a potential agent in the treatment of haematological malignancies. *Cancer Immunol Immunother* 58:351–360
 39. Magadán S, Sanjuán I, Valladares M et al. (2004) A new potential therapeutic agent against B cell malignancies. 12th annual international congress of immunology/4th annual conference of the Federation-of-Clinical-Immunology-Societies (FOCIS), Montreal, Canada, 2004. In: Medimond international proceedings, pp 409–422
 40. Nicholson I, Zou X, Popov A, Cook G, Corps E, Humphries S et al (1999) Antibody repertoires of four- and five-feature translocus mice carrying human immunoglobulin heavy chain and kappa and lambda light chain yeast artificial chromosomes. *J Immunol* 163:6898–6906
 41. Xu J, Davis M (2000) Diversity in the CDR3 region of V(H) is sufficient for most antibody specificities. *Immunity* 13:37–45
 42. Ishida I, Tomizuka K, Yoshida H, Tahara T, Takahashi N, Ohguma A et al (2002) Production of human monoclonal and polyclonal antibodies in TransChromo animals. *Cloning Stem Cells* 4:91–102
 43. Green L (1999) Antibody engineering via genetic engineering of the mouse: XenoMouse strains are a vehicle for the facile generation of therapeutic human monoclonal antibodies. *J Immunol Methods* 231:11–23
 44. Ni J (2009) New technologies for the generation of human monoclonal antibody. *Trends Biopharm Ind* 5:3–12
 45. Beck A, Wurch T, Bailly C, Corvaia N (2010) Strategies and challenges for the next generation of therapeutic antibodies. *Nat Rev Immunol* 10:345–352
 46. Galfrè G, Howe S, Milstein C, Butcher G, Howard J (1977) Antibodies to major histocompatibility antigens produced by hybrid cell lines. *Nature* 266:550–552
 47. Galfrè G, Milstein C (1981) Preparation of monoclonal antibodies: strategies and procedures. *Methods Enzymol* 3:3–46
 48. Lefranc M (2003) IMGT, the international ImMunoGeneTics database. *Nucleic Acids Res* 31:307–310
 49. Dewar V, Voet P, Denamur F, Smal J (2005) Industrial implementation of *in vitro* production of monoclonal antibodies. *ILAR J* 46:307–313
 50. Nilson B, Lögdberg L, Kastern W, Björck L, Akerström B (1993) Purification of antibodies using protein L-binding framework structures in the light chain variable domain. *J Immunol Methods* 164:33–40
 51. Zou X, Xian J, Davies N, Popov A, Brüggemann M (1996) Dominant expression of a 1.3 Mb human Ig kappa locus replacing mouse light chain production. *FASEB J* 10:1227–1232
 52. Taylor L, Carmack C, Schramm S, Mashayekh R, Higgins K, Kuo C et al (1992) A transgenic mouse that expresses a diversity of human sequence heavy and light chain immunoglobulins. *Nucleic Acids Res* 20:6287–6295
 53. Lonberg N, Taylor LD, Harding FA, Trounstein M, Higgins KM, Schramm SR et al (1994) Antigen-specific human antibodies from mice comprising four distinct genetic modifications. *Nature* 368:856–859
 54. Brüggemann M, Neuberger MS (1996) Strategies for expressing human antibody repertoires in transgenic mice. *Immunol Today* 17:391–397
 55. Wagner S, Gross G, Cook G, Davies S, Neuberger M (1996) Antibody expression from the core region of the human IgH locus reconstructed in transgenic mice using bacteriophage P1 clones. *Genomics* 35:405–414
 56. Mendez M, Green L, Corvalan J, Jia X, Maynard-Curie C, Yang X et al (1997) Functional transplant of megabase human immunoglobulin loci recapitulates human antibody response in mice. *Nat Genet* 15:146–156
 57. Jakobovits A, PubMed P (1998) Production and selection of antigen-specific fully human monoclonal antibodies from mice engineered with human Ig loci. *Adv Drug Deliv Rev* 1:1–2
 58. Tomizuka K, Yoshida H, Uejima H, Kugoh H, Sato K, Ohguma A et al (1997) Functional expression and germline transmission of a human chromosome fragment in chimaeric mice. *Nat Genet* 16:133–143

59. Davies NP, Rosewell IR, Richardson JC, Cook GP, Neuberger MS, Brownstein BH et al (1993) Creation of mice expressing human antibody light chains by introduction of a yeast artificial chromosome containing the core region of the human immunoglobulin kappa locus. *Biotechnology (N Y)* 11:911–914
60. Fishwild DM, O'Donnell SL, Bengoechea T, Hudson DV, Harding F, Bernhard SL et al (1996) High-avidity human IgG kappa monoclonal antibodies from a novel strain of minilocus transgenic mice. *Nat Biotechnol* 14:845–851
61. Popov A, Zou X, Xian J, Nicholson I, Brüggemann M (1999) A human immunoglobulin lambda locus is similarly well expressed in mice and humans. *J Exp Med* 189:1611–1620
62. Nitschke L, Kosco M, Köhler G, Lamers M (1993) Immunoglobulin D-deficient mice can mount normal immune responses to thymus-independent and -dependent antigens. *Proc Natl Acad Sci USA* 90:1887–1891
63. Oettgen H, Martin T, Wynshaw-Boris A, Deng C, Drazen J, Leder P (1994) Active anaphylaxis in IgE-deficient mice. *Nature* 370:367–370
64. Erlandsson L, Andersson K, Sigvardsson M, Lycke N, Leanderson T (1998) Mice with an inactivated joining chain locus have perturbed IgM secretion. *Eur J Immunol* 28:2355–2365
65. Zou Y, Takeda S, Rajewsky K (1993) Gene targeting in the Ig kappa locus: efficient generation of lambda chain-expressing B cells, independent of gene rearrangements in Ig kappa. *EMBO J* 12:811–820
66. Takeda S, Zou Y, Bluethmann H, Kitamura D, Muller U, Rajewsky K (1993) Deletion of the immunoglobulin kappa chain intron enhancer abolishes kappa chain gene rearrangement in cis but not lambda chain gene rearrangement in trans. *EMBO J* 12:2329–2336
67. Chen J, Trounstein M, Kurahara C, Young F, Kuo CC, Xu Y et al (1993) B cell development in mice that lack one or both immunoglobulin kappa light chain genes. *EMBO J* 12:821–830
68. Sanchez P, Drapier A, Cohen-Tannoudji M, Colucci E, Babinet C, Cazenave P (1994) Compartmentalization of lambda subtype expression in the B cell repertoire of mice with a disrupted or normal C kappa gene segment. *Int Immunol* 6:711–719
69. Zou X, Xian J, Popov A, Rosewell I, Müller M, Brüggemann M (1995) Subtle differences in antibody responses and hypermutation of lambda light chains in mice with a disrupted chi constant region. *Eur J Immunol* 25:2154–2162
70. Tomizuka K, Shinohara T, Yoshida H, Uejima H, Ohguma A, Tanaka S et al (2000) Double trans-chromosomic mice: maintenance of two individual human chromosome fragments containing Ig heavy and kappa loci and expression of fully human antibodies. *Proc Natl Acad Sci USA* 97:722–727

Chapter 14

Phage Display Technology for Human Monoclonal Antibodies

Cecilia Deantonio, Diego Cotella, Paolo Macor, Claudio Santoro, and Daniele Sblattero

Abstract

During the last 15 years in vitro technologies opened powerful routes to combine the generation of large libraries together with fast selection procedures to identify lead candidates. One of the commonest methods is based on the use filamentous phages. Antibodies (Abs) can be displayed successfully on the surface of phage by fusing the coding sequence of the antibody variable (V) regions to the phage minor coat protein pIII. By creating large libraries, antibodies with affinities comparable to those obtained using traditional hybridomas technology can be selected by a series of cycles of selection on antigen. As in this system antibody genes are cloned simultaneously with selection they can be easily further engineered for example by increasing their affinity (to levels unobtainable in the immune system), modulating their specificity or their effector function (by recloning into a full-length immunoglobulin scaffold). This chapter describes the basic protocols for antibody library construction, handling, and selection.

Key words Phage display, Antigens, Monoclonal antibody, High-throughput, scFv

1 Introduction

Traditional methods to generate monoclonal antibodies rely on the immunization of laboratory animals and the subsequent selection of immortalized clonal hybridoma cells. The process is laborious, requires costly animal houses and its efficacy depends on the ability of the immune system to mount a humoral productive response to the potential antigens. The advent of molecular biology has brought in the field new potentialities allowing to recapitulate in vitro the complete process of antibody production, by-passing immunization, animal handling, and the laborious process of selection. The essential of in vitro methods is the cloning of antibody fragments in a format suitable for selection. A great advantage of in vitro methods to generate antibodies is speed, high throughput potential and flexibility of the approach: antibodies

can be selected and their affinities and specificities can be precisely tailored according to the needs. Phage [1, 2] and yeast display [3, 4] are the commonest methods for this purpose.

In 1985, G.P. Smith [5] first introduced the concept of displaying exogenous proteins on the surface of M13 phages, setting the basis to build libraries displaying large repertoire of different proteins. Antibody display libraries have been the most successful applications of this concept [6]. The general concept beyond this display technology is that a large library of antibodies of potential interest is created, from which ones with desirable properties can be selected. A phage displaying a specific antibody on its surface could be isolated for its binding property to a target ligand from a collection of billions of phages displaying different antibodies. Furthermore, since the phage displays proteins encoded by its genome, the selection of a phage allows the concomitant cloning of the corresponding antibody gene that is then easily identified by DNA sequencing (*see Fig. 1*).

In order to carry out this procedure a number of crucial steps are required.

First, a library must be created that contains the DNA sequences encoding the antibody diversity. V fragments are inserted into a vector in frame to the sequence encoding the phage protein p3. Thus once assembled, the phage particle will harbor a p3 protein displaying at its amino terminus a functional antibody fragment. In the creation of such libraries two different choices can be made:

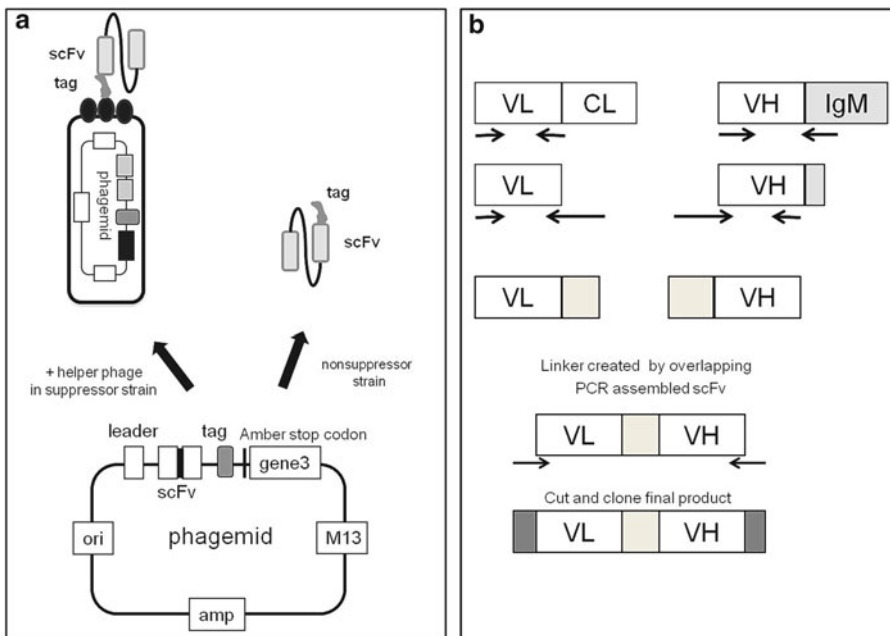

Fig. 1 (a) Schematic of a phagemid display vector. (b) PCR assembly of V genes into an scFv format

(a) the antibody format; (b) the source of V region repertoire. In general successful approaches have been using either the single chain fragment variables [7] format, consisting in a VH and VL regions linked by a flexible linker, or the Fab format, in which VH–CH1 and VL–CL associate non-covalently [8]. V genes repertoires can be recovered by the RT-PCR amplification of the entire repertoire of antibody variable (V) gene fragments from lymphoid tissue RNAs using defined sets of primers [9] or they can be generated de novo by gene synthesis. Such naïve libraries have proved to be potent sources of antibodies against many different targets [1, 10, 11], including those poorly antigenic in animals. As an alternative antibody libraries have been created synthetically by introducing diversity using oligonucleotides into frameworks with desirable properties [12–14]. In this case although originally completely degenerate oligonucleotides were used to generate diversity [15] more recently it has been found that the use of diversity restricted to only three or four amino acids can provide antibodies with similarly high affinities [14].

Second, once library is created, the enrichment of antigen specific phage antibodies is carried out by “phage panning,” using immobilized [16] or labeled antigen [17]. In this process, the antigen of interest is immobilized on a solid support, such as microplate wells or magnetic beads. The phage particles are then added to allow binding of phage that display appropriate antibodies. After extensive washing to remove all nonspecifically bound material, phage that display a relevant antibody will be retained while non-adherent phages will be washed away. The selection procedure is repeated two to five rounds (the only requirements are the good quality and abundance of the target to allow several cycles of selection to be performed) resulting in a population that consists to a high percentage of phage that express the desired antibodies (i.e., those that bind the antigen of interest). Bound phages are then recovered, used to infect bacteria and grown for further enrichment and eventually for binding analysis. The possibility to perform successive rounds of selection permits the isolation of proteins present in very low number in a population of billions of different phages. A typical selection round is illustrated in Fig. 2.

Finally, the antibodies specific for the given antigen are identified through a screening, by ELISA or FACS, within a number of random clones. Furthermore, as antibody genes are directly identified by sequencing they can be subjected to downstream genetic engineering, for instance to increase affinity (through generation of secondary libraries of mutated antibodies) and/or to build full-length immunoglobulin with desired effector functions.

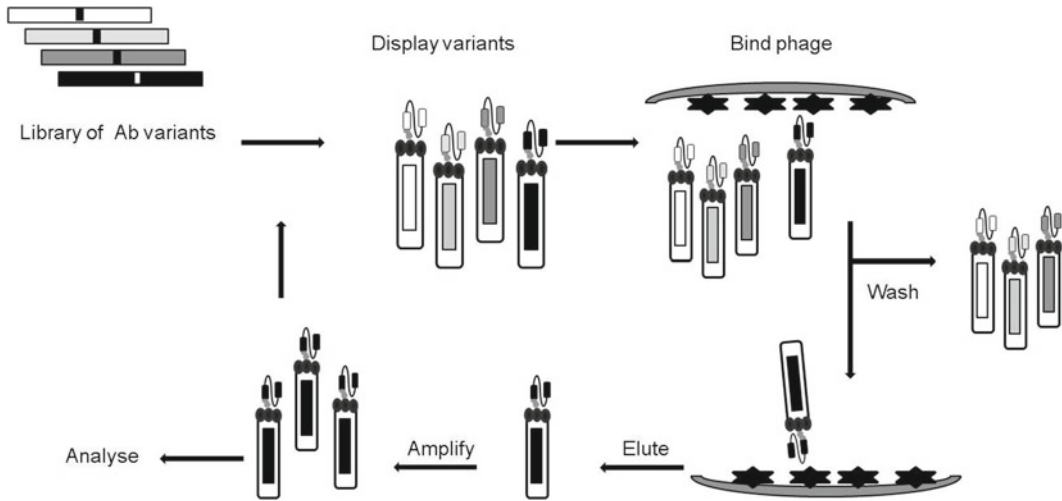

Fig. 2 Phage display selection cycle. Up to five rounds of selection over a specific target are performed; in each round, unreactive clones are removed and reactive clones are amplified. Positive clones are successively isolated and identified by DNA sequencing

2 Materials

2.1 Construction of Antibody Libraries

1. Bacterial strain used is *Escherichia coli* DH5 α F' [F'/endA1 hsd17(rK_mKp) supE44 thi-1 recA1gyrA (Nalr) relA1 _ (lacZYA-argF) U169 deoR (F80dlacD-(lacZ)M15)].
2. Ficoll-Paque PLUS (GE Healthcare).
3. Plasmidic DNA is prepared using the Macherey-Nagel Nucleospin Plasmid kit, following the instructions of the manufacturer.
4. Stock solutions of antibiotics are prepared by dissolving kanamycin at 50 mg/mL in water and ampicillin at 100 mg/mL in water. Kanamycin and ampicillin stocks are kept at -20°C . Repeated freeze and thaw of ampicillin is avoided, and aliquots are prepared for single use. All antibiotics are purchased from Sigma.
5. 2xTY liquid broth is prepared adding, for 1 L, 16 g bacto-tryptone, 10 g bacto-yeast, and 5 g NaCl to ddH₂O. Final pH 7.0. Agar plates are prepared by adding 1.5 % bacto-agar to 2xTY broth. Make up to 1 L with distilled water, autoclave and allow to cool to 55°C . At this temperature antibiotics and glucose can be added, prior to pouring into plates.
6. Glycerol molecular biology grade (60 % v/v), autoclaved.
7. All restriction endonucleases, T4 ligase and buffers are purchased from New England Biolabs. All cloning steps are performed according to the manufacturer suggestions and to standard molecular biology procedures.

8. The NucleoTrap kit and NucleoTrap[®]CR kit (Macherey–Nagel) are used for purification of DNA from agarose gel and reaction mixtures, respectively, following the instructions of the manufacturer.
9. 100 μ L aliquots of electrocompetent DH5 α F' bacteria are used for transformation; each aliquot is used for transformation of 1.5 μ L of purified DNA, using 1 mm gap cuvette (Eppendorf).

2.2 Phage Production and Titration

1. Helper phage M13KO7: purchased from GE Healthcare or Life Agilent Technologies.
2. Solution for precipitation of phages: 20 % (w/v) polyethylene glycol (PEG) 6000 and 2.5 M NaCl (purchased from Fluka). The solution is filtered through a 0.22 μ m filter before use, store at room temperature.
3. PBS: 8 g NaCl, 0.2 g KCl, 1.44 g Na₂HPO₄, and 0.24 g KH₂PO₄ in 1 L H₂O, final pH 7.4.
4. 2xTYAG: add 100 μ g/mL ampicillin and 2 % of glucose to 2xTY liquid broth.
5. 2xTYAK: add 100 μ g/mL ampicillin and 25 μ g/mL kanamycin to 2xTY liquid broth.

2.3 Phage Selection to Immobilized Antigen

1. Nunc Immuno MaxiSorb Tubes (Nunc, cat. no. 444202).
2. Antigen of interest dissolved in either carbonate buffer (pH 9.6) or PBS at a concentration of 1–100 μ g/mL.
3. Carbonate buffer: mix 0.1 M Na₂CO₃ and 0.1 M NaHCO₃ until pH 9.6. 0.1 M Na₂CO₃, 10.6 g Na₂CO₃/L H₂O; 0.1 M NaHCO₃ 8.4 g NaHCO₃/L H₂O.
4. PBS–Tween-20: add 1 g Tween-20 per liter of PBS.
5. 2 % MPBS: 2 g nonfat milk powder/100 mL PBS.
6. 4 % MPBS: 4 g nonfat milk powder/100 mL PBS.
7. 100 mM triethylamine: 140 μ L triethylamine/10 mL H₂O. Prepare fresh; pH must be 12.

2.4 Immuno-precipitation with Magnetic Beads

1. Biotinylated antigen, 100–500 nM, best done using a commercial kit (e.g., Pierce).
2. Streptavidin-coupled Dynabeads M-280 (Life Sciences).
3. Small magnets designed for fitting of 1.5–2 mL tubes.
4. 100 mM triethylamine: 140 μ L triethylamine/10 mL H₂O. Prepare fresh; pH must be 12.
5. 1 mM DTT.

2.5 Phage ELISA

1. Antigen: 1–100 µg/mL dissolved in either carbonate buffer or PBS.
2. For antigen immobilization by absorption Nunc MaxiSorb 96-well plates (Nunc, cat. no. 442404).
3. Anti-phage mAb (GE Healthcare, cat. no. 27-9421-01) and other companies sell an anti-phage monoclonal antibody already coupled to HRP (horseradish peroxidase). Usually used at 1/5,000.
4. TMB (3,3',5,5'-tetramethylbenzidine) ready-to-use, pre-mixed solution for colorimetric HRP-based ELISA detection
5. 2 N sulfuric acid: 55.6 mL 97 % sulfuric acid dilute up to 1 L H₂O.

2.6 Soluble ELISA

1. Antigen: 1–100 µg/mL dissolved in either carbonate buffer or PBS.
2. For antigen immobilization by absorption on Nunc MaxiSorb 96-well plates (Nunc, cat. no. 442404).
3. Monoclonal antibody anti-immunoaffinity tag (e.g., 9E10 anti-myc, anti HIS6, anti V5) for detection of soluble scFv.
4. Appropriate horseradish peroxidase (HRP)-conjugated anti-mouse IgG.
5. (3,3',5,5'-tetramethylbenzidine) ready-to-use, pre-mixed solution for colorimetric HRP-based ELISA detection.
6. 2 N sulfuric acid: 55.6 mL 97 % sulfuric acid dilute up to 1 L H₂O.

3 Methods

3.1 V Genes Amplification from Peripheral Blood Lymphocytes

A library with the maximum antibody diversity could be generated by amplifying naturally rearranged V genes. There are two requirements: the availability of peripheral blood lymphocytes (PBLs) from several non-immunized donors and a set of PCR primers able to amplify all known VH, Vκ, and Vλ gene sequences [9, 18].

1. Samples of human PBLs are purified by density gradient centrifugation on Ficoll Hypaque and are used as starting material (*see Note 1*).
2. Total RNA is prepared by using a commercial kit (e.g., Qiagen). The quality of the RNA preparation should be checked on an appropriate gel.
3. cDNA is synthesized using Reverse Transcriptase and random hexamer primers starting with 1–5 µg of total RNA in a final volume of 20 µL following instructions provided.

4. VH genes are amplified by PCRs and a reaction should be carried out for each individual VH-Back primers (as described in [9]) in order to amplify even rarely occurring VH genes. VH back primers are paired with an IgM constant-region primer. Reaction volumes is 20 μ L, using 0.5 μ L of cDNA reaction, 10 pmol of each primer, 200 μ M dNTPs, 2 μ L 10 \times PCR buffer, and 0.5 μ L (2.5 U) of Taq DNA polymerase. Cycling parameters are 94 $^{\circ}$ C for 1 min (denaturation), 55 $^{\circ}$ C for 1 min (annealing), and 72 $^{\circ}$ C for 1 min (extension) for 30 cycles. All 20 μ L are loaded on a 1.5 % agarose gel and gel purified.
5. V λ and V κ genes are similarly amplified (using individual VL-back primers with the mix of VL-for primers) from random primed cDNA with the same cycling parameters. All 20 μ L are loaded on a 1.5 % agarose gel and gel purified using a purification kit.
6. Pull through PCR of amplified V regions. V regions amplified from cDNA are re-amplified to increase the amount available for cloning as well as to add extra DNA sequence (e.g., for restrictions sites) at each end. As the starting template is a PCR fragment this amplification tends to be extremely efficient. VH (and VL) purified genes are pooled equally and re-amplified using external primers (*see* Fig. 1b) in 50 μ L volumes using 1 μ L of purified VH (other parameters as above). All 50 μ L are loaded on a 1.5 % agarose gel and gel purified.
7. The scFv library is assembled by mixing equal amounts (200–500 ng) of VH and VL genes and performing assembly essentially as described in [19]: 8 cycles of PCR without primers followed by 25 cycles in the presence of external primers. Cycling parameters are 94 $^{\circ}$ C for 1 min (denaturation), 60 $^{\circ}$ C for 1 min (annealing) and 72 $^{\circ}$ C for 1 min 30 s (extension). Five assembly reaction of 50 μ L should be set up and product purified on a 1.5 % agarose gel.

3.2 Ligation and Electroporation of ScFv Library

In general, the diversity of a library is limited by the amount of vector/insert used and by the transfection efficiency of bacteria, and the largest libraries require hundreds of electroporations to generate the required diversity (*see* Note 2).

1. 5 μ g of phagemid cloning vector pDAN5 [11] and 1 μ g purified scFvs are sequentially digested, first with BssHIII restriction endonuclease for 3 h at 50 $^{\circ}$ C, then with NheI for 2 h at 37 $^{\circ}$ C. Efficient digestion with both enzymes is crucial to avoid self-ligation of the vector and high backgrounds at transformation. Both vector and scFv insert are loaded on an agarose gel and gel purified using a purification kit.
2. Ligation reaction is prepared as follow: double-digested and purified vector 2–5 μ g, double digested and purified scFv

0.5–1 μg (phagemid: insert molar ratio of 1:3, 1:5); T4 ligase; 1 \times ligase buffer. Incubate reactions at 15 °C overnight (*see Note 3*).

3. Clean up ligation either by using a commercial DNA cleanup kit or by phenol extraction and ethanol precipitation.
4. Elute or resuspend the DNA in 40 μL H_2O .
5. The ligation mix is electroporated into electrocompetent DH5 α F'. 20–40 electroporations should be performed. The cuvettes should be kept at –20 °C until ready for use (*see Note 4*).
6. After electroporation, rescue cells by quickly adding to each 1 mL 2xTY, transfer to a 5-mL tube and incubate at 37 °C for 1 h. Pool transformations and plated on 2xTYAG 15 cm plates and grow O/N at 25–28 °C to obtain a primary library. Make dilutions to estimate library diversity.
7. The next day colonies are scraped up in 2xTY 10 % glycerol and frozen down in 1 mL aliquots.

3.3 Rescuing Phagemid Particles from Libraries

Growth of phagemid libraries requires the use of helper phage, which provides all the other proteins needed to produce the phage particles. The different clones of the library have very different effects on bacterial growth rates, therefore library amplification should be minimized to prevent bias towards the least toxic clones. The purpose of the helper phage (a phage with a packaging signal disabled or weaker than that of phagemid vector) is to provide all the proteins required for phagemid replication, ssDNA production, and packaging.

1. The starting culture should contain at least ten times more clones than the original library diversity but should not exceed $\text{OD}_{600\text{nm}}$ 0.05. For most rescues, the inoculum is therefore 30–300 μL of the glycerol stock (or concentrated solution of bacteria scraped from plate). The inoculum should be placed in an appropriate volume of 2xTYAG in a sterile flask 5–10 times bigger than the culture volume.
2. Grow with shaking (250 rpm) for 1.5–2.5 h at 37 °C, to an $\text{OD}_{600\text{nm}}$ of 0.5. check the OD regularly so not to overgrow the cells (this growth will get the cells into mid-log phase so that they express the F-pilus for infection) (*see Note 5*).
3. When an $\text{OD}_{600\text{nm}}$ of 0.5 is reached, add a 20-fold excess of helper phage (consider cell concentration as 3×10^8 mL). Leave at 37 °C for 45 min, standing with occasional agitation.
4. Spin the cells for 10 min at 4,000 $\times g$. When bacteria need to be kept vital, they should be spun no greater than 4,000 $\times g$. When they are to be removed to collect supernatant, higher g forces can be used.
5. Discard the supernatant.

6. Dissolve the bacterial pellet in a volume five times greater than the initial culture volume of 2xTYAK. Grow shaking (250 rpm) overnight at 28–30 °C, using enough flasks to ensure that the flask volume is 5–10 times greater than the culture volume.
7. The following day bacteria are centrifuged at 6,300–15,000 rfc for 25 min at 4 °C. The supernatant, containing phages, is collected and subject to PEG precipitation.

3.4 PEG Precipitation of Phagemid Particles

The concentration of phage or phagemid particles in the supernatant of culture medium is usually 10^{11-12} per mL. It is often useful to remove bacterial debris and concentrate phages. This is best done by PEG precipitation. The addition of polyethylene glycol (average molecular weight 6,000) to a final concentration of 1–4 % (w/v) results in precipitation of essentially all phage particles [20]. Particles are dissolved in PBS and re-centrifuged to remove bacteria, prior to a second PEG precipitation and filter sterilization, if desired.

1. Add 1/5 volume of PEG/NaCl solution to the cleared supernatant (e.g., 20–100 mL), mix well and leave for 30–60 min on ice. Successful precipitation can usually be seen after few minutes as haziness.
2. Spin down at $4,000 \times g$ for 15 min at 4 °C; discard supernatant. The pellet should be white. If it is brown, this is usually due to contamination with bacteria, and the PEG precipitation should be repeated.
3. Dissolve phage pellet in 1/10 original volume with PBS.
4. Spin in microcentrifuge (10 min, max speed) to remove the remaining bacteria, a small brown pellet could be visible. Transfer supernatant to a new tube.
5. **Steps 1–4** can be repeated for added purity (double PEG precipitation), and especially if the first PEG precipitate is brown, and should always be done for prolonged storage of phage preparations. In this case add 1/5 PEG solution to the supernatant; leave on ice for 10–20 min; haziness should be seen immediately. Spin phage down (5 min, max speed), remove supernatant carefully and dissolve the pellet in PBS 1/50 of the original volume with a blue 1 mL filter-tip. Remove bacteria again by spinning (2 min, max speed).
6. The phages are now ready for selection. The standard titer after double precipitation should be about $2-10 \times 10^{13}$ phages/mL. Although phages can be stored at 4 °C without much loss of titer the displayed antibodies will proteolytically be removed by contaminating proteases so they should be used within few days (*see Note 6*).

3.5 Phage Titration into *E. coli*

Phagemid concentration should be titrated both before the selection as well as after (eluted phages). *E. coli* expressing F-pili are infected by phagemid and after appropriately dilution plated into 2xTY agarose plates with the appropriate antibiotic to form colonies after O/N growth. Colonies will be formed only by those cells which have acquired antibiotic resistance which is a reflection of phage infection.

1. Make serial 10- to 100-fold dilutions of the phagemid solution in Eppendorf tubes in 2xTY medium to final volumes of 1 mL, i.e., 10 μ L into 990 μ L (10^{-2}), 10 μ L of this into 990 μ L (10^{-4}), etc. For accurate titrations make tenfold rather than 100-fold dilution steps around the relevant dilutions. Use new sterile tips for pipetting each titration step, otherwise the titration is inaccurate. For phagemid stocks after PEG precipitation (10^{12-13} phages/mL) go down to 10^{-10} ; for phagemid eluates (10^{6-8} phages/mL at round 1–2 of selections) go down to 10^{-6} .
2. Add 10 μ L of the diluted phages to 1 mL of exponentially growing *E. coli*. Incubate without shaking at 37 °C for 45 min.
3. Plate 100 μ L of each dilution onto 2xTYAG plates overnight at 28 °C.
4. As a control, uninfected *E. coli* should be plated and grown on a separate ampicillin plate. If colonies grow on this plate it indicates possibly an infection of contaminating phagemid indicating inadequate sterile techniques.
5. Next day, count the number of colonies and calculate the phage titer. Titer is expressed as number of phages/mL.

3.6 Selection of Phage Antibodies to an Antigen Immobilized on Plastic Surfaces

While many different plastic surfaces are suitable for selections, immunotubes (Nunc) have become the standard. They have a high capacity (600 ng/cm²) and have yielded many specific antibodies from a number of different antibody libraries. Surfaces can be coated with antigen in a variety of ways, the most common being direct adsorption to a plastic surface where it is non-covalently associated via electrostatic and van der Waals interactions. Usually antigen is coated at 1–10 μ g/mL and conditions which work for ELISA are likely to work for selection. Nonfat powdered milk is the standard blocking reagent. Tween 20 0.1–0.5 % can also be added to all incubation to reduce nonspecific or polyreactive binders. After antigen coating the phagemid library is incubated in direct contact with plastic surface. Washes are then performed and in principle non-binding phages are washed away while specific phages will be retained and later rescued by infection. In practice, this cannot be carried out in a single cycle, but requires a number of rounds of binding, washing, elution and amplification. In general two to four cycles are usually required.

1. Add 1 mL antigen to a 75 mm×12 mm Nunc-immunotube. Leave O/N at 4 °C (or 1 h at 37 °C). Next day, wash 3× with PBS (simply pour solution in and pour out again immediately).
2. Block the immunotube by adding 2 % MPBS to the rim. Seal the tube with parafilm and leave for 30 min to 2 h at room temperature. Meanwhile, preblock PEG-concentrated phage ($1-5 \times 10^{12}$ phages) in a final volume of 1 mL with 2 % MPBS (*see Note 7*).
3. Wash the immunotube 2× with PBS–Tween-20 and 2× with PBS and transfer phage-mix (**step 2**) to immunotube and cover tube with parafilm. Incubate for 30 min on a rotator and then for 1.5 h standing at room temperature.
4. Wash tubes with 20 washes PBS–Tween-20, then 20 washes with PBS (*see Note 8*). Each washing step is performed by pouring buffer in and out immediately (*see Note 9*). This is best achieved using a wash bottle.
5. Elute phage from tube by adding 1 mL 100 mM triethylamine. Cover tube with fresh parafilm (this prevents cross contamination) and rotate the tube for 10 min on an under and over turntable. Do not increase elution time as phage viability decreases.
6. Transfer solution to an Eppendorf tube with 0.5 mL of 1.0 M Tris–HCl, pH 7.4 and mix by inversion. It is necessary to neutralize the phage eluate immediately after elution.
7. Transfer phage mix to ice or store at 4 °C.
8. Titrate the phage in DH5 α F' cells to determine the output.
9. Re-infect the selected phages in DH5 α F' cells and harvest phage (*see Subheading 3.3*).
10. Start new round of selection.
11. An alternative methods to elute selected phages from the immunotube include adding 1 mL of bacteria at OD_{600nm} 0.5 (*see Note 10*) and leaving the tube at 37 °C for 30–45 min with occasional shaking. In this case bacteria are plated directly on 2 cm×15 cm 2xTY agar plates added with ampicillin and grown O/N at 28 °C.

3.7 Selection of Phage Antibodies Using Biotinylated Antigen and Streptavidin-Paramagnetic Beads

An alternative to selecting antibodies bound to plastic plates is to select the antibodies in solution. This solves problems related to antigens that change conformation when directly coated onto solid surfaces. Furthermore, affinity selections are more straightforward with this method allowing a precise control of the interaction between the phage particle and the antigen that takes place in solution. The antigen is labeled by biotinylation (using the kits which are sold by many companies) and incubated with the phage antibody library, after both have been appropriately blocked.

Once the interaction between the two has occurred the complex can be retrieved by using magnetic beads coated with streptavidin. Specificity is achieved by washing the beads several times. Phages are eluted from the beads with either acid or alkaline solution.

1. Phage preparation (corresponding to 10^{12} phages) is saturated to a final concentration of 2 % MPBS in 500 μ L volume.
2. 100 μ L streptavidin-magnetic beads are added to select streptavidin binding phage. Solution is equilibrated on rotator at room temperature for 60 min.
3. Remove the streptavidin binding phage by drawing the beads to one side using a magnet and removing the supernatant.
4. Add biotinylated antigen (100–500 nM) to the equilibrated phage mix.
5. Incubate on rotator at room temperature for 30 min to 1 h.
6. While incubating the phage wash 100–200 μ L streptavidin-magnetic beads with PBS and resuspend in 2 % MPBS on rotator at room temperature for 30 min to 1 h.
7. Draw equilibrated beads to one side with magnet, remove buffer and resuspend beads with phage-antigen mix and incubate on rotator at room temperature for 15 min (*see Note 11*).
8. Place tubes in magnetic rack and wait until all beads are bound to the magnetic site (30 s). Wash the beads from the cap by tipping rack upside down and back again.
9. Leave tubes in the rack for 1–2 min then aspirate the tubes carefully, leaving the beads on the side of the tube.
10. Wash the beads carefully six times with 0.75 mL PBS–Tween-20.
11. Wash the beads four times with 0.75 mL PBS.
12. Elute phage from beads with 500 μ L 100 mM TEA for 10 min incubation maximum.
13. Transfer the solution to an Eppendorf tube containing 250 μ L Tris–HCl, pH 7.4 and mix by inversion. It is necessary to neutralize the phage eluate immediately after elution.
14. Use an aliquot of the selected phages to re-infect in DH5 α F' cells for another round of selection, repeating all steps above.
15. Store the remaining beads or eluate at 4 °C as a backup.
16. Bound phages could be eluted by mixing the beads with 1 mL of *E. coli* DH5 α F', at OD_{600nm} 0.5, at 37 °C, for 45 min, with occasional shaking (*see Note 10*). In this case bacteria are plated on 2 cm \times 15 cm 2xTY agar plates added with ampicillin and grown O/N at 28 °C.

3.8 Library Amplification After Selection

1. In the case of immunotube selection mix 5 mL of DH5 α F' cell with 0.5 mL of phage eluate (*see Note 12*) in a 50-mL Falcon tube. The eluate must be diluted at least tenfold (for toxicity reasons) if TEA has been used for elution.
2. For soluble biotinylated antigen selections mix 1 mL of *E. coli* with 100–200 μ L of phage eluate (*see Note 12*).
3. Incubate at 37 °C for 30 min with occasional shaking.
4. Plate out samples on 2 cm \times 15 cm 2xTYAG plates. For later rounds of selection, one plate is sufficient, as diversity is reduced.
5. Grow the plates O/N at 28 °C. Growth at higher temperatures may lead to loss of some antibody clones.
6. After overnight growth add 2 mL into 2 cm \times 15 cm plates and scrape the bacteria off using a sterile spreader.
7. Transfer the cells to a Falcon tube, and make a homogeneous suspension by pipetting up and down with a sterile pipette.
8. Add sterile glycerol to 15 % final concentration and immediately store at –80 °C samples into a Cryotube in at least two aliquots.
9. Rescue phage from library according to Subheading 3.3.

3.9 Growing Phage Clones in Microtiter Plates for ELISA Testing

After two or three rounds of selection, individual colonies from the selection are tested for antigen binding by ELISA. A microtiter-well system can be used for individual phage preparation. The principle involving growth, helper phage infection, and phage production is the same as that for the library, but it is applied to single clones in the 96-well plate format. Care must be taken to prevent cross-contamination between wells; both growth and ELISA controls should be included on the master plates.

1. Put 100 μ L of 2xTYAG into each well of a 96-well flat-bottomed plate. Inoculate a single colony in each well by touching the top of a colony with an autoclaved toothpick or sterile plastic tip. Grow with shaking (250 rpm) overnight at 30 °C (*see Note 13*). There is no need for specific holder designed for microtiter plates, this could be inserted within a plastic box cushioned with foam, tightly taped and placed as far as possible from the ventilator to avoid evaporation (*see Note 14*).
2. Next day, use a 96-well sterile transfer device or pipet to inoculate 2 μ L per well from this plate to a 96-well induction plate containing 120 μ L 2xTYAG per well. Use round-bottomed 96-well plates. Grow to OD_{600nm} 0.5 (around 2.5 h), at 37 °C, shaking.
3. To each well add 50 μ L 2xTYAG containing 1×10^9 pfu helper phage. The ratio of phage to bacterium should be about 20:1. Stand 30 min at 37 °C.

4. After the incubation, spin at 500 rfc as faster will crack the plates for 10 min; then remove the supernatant with a multi-channel pipette or suction device.
5. Resuspend the bacterial pellet in 150 μL 2xTYAK. Glucose is omitted in this step. Grow overnight 28 °C shaking.
6. Next day, spin at 500 rfc (faster will crack the plates) for 10 min and use 50 μL supernatant per well for phage ELISA.

3.10 Phage ELISA

1. Coat plate with 100 μL per well of protein antigen used for selections. Coating is in PBS, and occasionally in carbonate buffer. Leave O/N at 4 °C or at 37 °C for 1 h. This is dependent upon the particular antigen and should be tested if possible (*see Note 15*).
2. Discard the antigen solution, rinse wells twice with PBS and block with 120 μL per well of 2 % MPBS, for at least 45 min at room temperature.
3. Wash wells twice with PBS.
4. Add 50 μL 4 % MPBS and 50 μL culture supernatant containing the phage antibodies to the appropriate wells, mix carefully. Leave approximately 1.5 h at room temperature with mild shaking.
5. Discard solution, wash out wells 3 \times with PBS–Tween-20 and 3 \times with PBS.
6. Add 100 μL diluted HRP conjugated mouse anti-phage mAb. Use the dilution indicated by the manufacturer. Incubate for 1 h at room temperature.
7. Discard solution and wash wells 3 \times with PBS–Tween-20 and 3 \times with PBS.
8. Dispense 100 μL TMB solution per well, leave at room temperature in the dark for 5–20 min (sometimes longer).
9. Quench by adding 50 μL stop solution 2 N H_2SO_4 .
10. Read at 450 nm.

3.11 Growing Soluble Fragments in Microtiter Plates

An alternative to using phagemids for ELISAs is to use antibody soluble fragments. The phagemid vector usually carries an amber stop codon between the gene coding for the scFv and the geneIII, and therefore, the gene coding for the scFv fragment is transcribed and soluble fragments are produced. The antibody leaks into the supernatant that could be directly used as primary antibody source.

1. Put 100 μL of 2xTYAG into each well of a 96-well flat-bottomed plate. Inoculate a single colony in each well by touching the top of a colony with an autoclaved toothpick or sterile plastic tip. Grow with shaking (250 rpm) overnight at 30 °C (*see Note 13*). There is no need for specific holder designed for microtiter

plates, this could be inserted within a plastic box cushioned with foam, tightly taped and placed as far as possible from the ventilator to avoid evaporation (*see Note 14*).

2. Next day, use a 96-well sterile transfer device or pipette to inoculate 2 μL per well from this plate to a 96-well induction plate containing 100 μL 2xTYA, 0.1 % glucose per well. Grow at 37 °C, shaking, until OD_{600nm} is approximately 0.6 (about 2–3 h).
3. Add 50 μL 2xTYA, 1.5 mM IPTG (final concentration 0.5 mM IPTG). Continue shaking at 25–28 °C O/N.
4. Next day, spin at 500 rfc for 10 min and use 50 μL supernatant in ELISA.

3.12 Soluble Fragment ELISA in Microtiter Plates

Soluble scFv can be tested for antigen binding activity on ELISA plates coated directly with antigens. Detection is done by a sandwich assay involving anti-tag antibody and a secondary enzyme-conjugated antibody.

1. Coat plate with 100 μL per well of protein antigen used for selections. Coating is in PBS, and occasionally in 100 mM sodium hydrogen carbonate, pH 9.6. Leave overnight at 4 °C or at 37 °C for 1 h. This is dependent upon the particular antigen and should be tested if possible.
2. Discard the antigen solution and rinse wells twice with PBS and block with 120 μL per well of 2 % MPBS, for at least 45 min at room temperature.
3. Wash wells twice with PBS.
4. Add 50 μL 4 % MPBS to all wells and then add 50 μL culture supernatant containing soluble antibody fragment to the appropriate wells. Leave 1.5 h at room temperature with mild shaking.
5. Discard solution, and wash out wells 3 \times with PBS–Tween-20 and 3 \times with PBS.
6. Pipette 100 μL of anti tag antibody, at the appropriate dilution, in 2 % MPBS into each well. Incubate at room temperature for 1 h.
7. Discard antibody, and wash out wells with 3 \times with PBS–Tween-20 and 3 \times with PBS.
8. Add 100 μL of diluted anti-mouse-HRP (horseradish peroxidase), or anti-mouse-AP (alkaline phosphatase), labeled secondary antibody to each well. Incubate for 1 h at room temperature.
9. Discard second antibody, and wash wells 3 \times with PBS–Tween-20 and 3 \times with PBS.

10. To develop with TMB: dispense 100 μL TMB solution per well, leave at room temperature in the dark for 10–30 min (sometimes longer). Quench by adding 50 μL stop solution (2 N H_2SO_4).
11. Read at 450 nm.

3.13 PCR Amplification and Fingerprinting of Selected Clones

After positive clones have been identified, it is important to determine how many different antibodies have been selected.

A simple and fast method involves using PCR to amplify the scFv regions and then to digest the DNA samples with a frequently cutting restriction enzyme, such as BstNI or HaeIII. The digested DNA fragments are separated on an agarose gel and the various clones are characterized by their own DNA fragment patterns.

1. Make up a PCR-Mastermix with 20 μL per clone. Use forward and back primers mapping external to the 5' and 3' end of the scFv insert.
2. Aliquot 20 μL of the Mastermix into 0.5 mL tubes, or into 96-well PCR microplates.
3. Add 0.5–1 μL of culture taken from the master plate into PCR reaction (excess bacteria in the PCR reaction can cause inhibition)
4. Heat to 94 $^\circ\text{C}$ for 10 min using the PCR-block. This is needed to break open the bacteria and release the template DNA. Cycle 30 times: 94 $^\circ\text{C}$, 1 min, 55–60 $^\circ\text{C}$, 1 min, 72 $^\circ\text{C}$, 1 min
5. Check 5 μL of the PCR reaction on a 1.5 % agarose-gel. This will indicate how many clones lack the insert.
6. Make up a fingerprinting-Mastermix and add 15 μL to each PCR tube.
7. Mastermix is as follow: BSA (10 $\mu\text{g}/\text{mL}$) 0.2 μL , BstNI buffer (10 \times) 3 μL , Water 11.6 μL , BstNI (10 U/ μL) 0.2 μL
8. Digest samples at 60 $^\circ\text{C}$ for 2–3 h.
9. Load on a 2 % agarose gel, run and compare the banding patterns of individual clones on a UV transilluminator.

4 Notes

1. Blood samples should be processed as soon as these are taken from the donor, prolonged storage on ice or at 4 $^\circ\text{C}$ results in the isolation of degraded RNA.
2. Large libraries are constructed by maximizing the efficiency of all reactions and protocols. Small decrease in the performances of protocols at any of these steps will easily lead to the production of libraries 10- to 100-fold smaller than expected. Optimized steps must include RNA extraction, PCR amplification, restriction

enzymes digestion, ligation, and purification. For an efficient ligation DNA fragments and vector must be fully cut, with no or little degradation, most of the vector can be re-ligated after cutting.

3. The ligation should be done using high-concentration T4 ligase enzyme O/N that works best rather than a few hours at room temperature. Cleanup of the large-scale ligation and resuspension in water is essential as high concentration of DNA is required without presence of any salts in solution, since the presence of contaminants leads to a dramatic decrease in the electroporation transformation efficiency.
4. Electrocompetent cells can be produced in-house or purchased from several manufacturers. The use of high-efficiency cells (above 5×10^9 transformants per μg of DNA) is required. In order to obtain highly electrocompetent cells, work as quickly as possible during resuspension of cells, and do not leave cells on ice any longer than necessary.
5. When infecting F' bacteria with phagemid, it is important to ensure that the bacteria are expressing the pilus. At the time of infection, bacteria should be in log-phase growth, with an $\text{OD}_{600\text{nm}}$ around 0.5. This $\text{OD}_{600\text{nm}}$ 0.5 could not be simply obtained by diluting bacteria grown to saturation (i.e., $\text{OD}_{600\text{nm}}$ 2.0). Bacteria should always be kept at 37 °C before infection as the pilus is lost after 2–3 min at room temperature. It is therefore strongly suggested to prepare in advance all reagents before removing the bacteria from the shaker, and to perform all steps quickly, without allowing the temperature to decrease.
6. For selection steps, it is therefore strongly suggested to use freshly prepared phages, and to store them at 4 °C for no longer than 1 day. Alternatively phages could be purified by CsCl gradient centrifugation, in this case they are stable for years if stored at –80 °C.
7. This blocking step is suggested to reduce background binding and should be performed in all selection rounds.
8. Sometimes problems with “stickiness” of antigens is a problem, in which case polyreactive clones may be selected from the repertoire. In that case inclusion of Tween-20 (0.05–0.1 %) in ALL incubation steps (in selection itself, in all washes and blocking steps) may help to remove these binders, reduce the background and favor the specific ones.
9. According to most experimental protocol, the stringency of the washing steps should increase with the selection rounds. We use the following procedure: tubes are washed 15 times with PBS–Tween-20 (0.05–0.1 %) and 15 times with PBS, to remove unbound phages, for the first round of selection. For the second round, 15 washes with PBS–Tween-20 (0.05–0.1 %) are followed by 20 min washing in rotation with PBS, followed by 20 more PBS washes.

10. It is important that bacterial culture has the correct OD_{600nm} for the elution step at the end of the selection. It is therefore necessary to start bacterial growth early enough so that at the end of the experiment (about 3 h) bacteria are in log-phase growth with an OD_{600nm} in the 0.3–0.6 range. It is suggested to grow bacteria in several tubes (only 1 mL is required for a single elution) inoculating different starting amounts of bacteria, and choose the tube with the OD_{600nm} closest to 0.5 for the final elution step.
11. Incubation with slow and constant rotation is required, since the beads quickly form deposits on the bottom of the tube.
12. It is advisable to use no more than half of the selected phages for amplification, since in the event of an error, one can always return and repeat the amplification.
13. This plate will be the “master plate” with the primary selected clones that are not infected by helper phage. Care should be taken to avoid contamination or mislabeling of the plate.
14. Growth conditions in microtiter plates (speed, temperature, and position of the plate in the incubator) should be tested during the first time growth.
15. The antigen can be recovered after coating for further use if needed. In this case overnight incubation at 4 °C is recommended.

Acknowledgments

This work was supported in part by Fondazione Cariplo, Compagnia Sanpaolo, NIH U54 DK093500-01. EC Marie Curie Research Training Network [contract no. MRTN-CT-20010-289964].

References

1. Marks JD et al (1991) By-passing immunization. Human antibodies from V-gene libraries displayed on phage. *J Mol Biol* 222(3):581–597
2. Scott JK, Smith GP (1990) Searching for peptide ligands with an epitope library. *Science* 249(4967):386–390
3. Boder ET, Midelfort KS, Wittrup KD (2000) Directed evolution of antibody fragments with monovalent femtomolar antigen-binding affinity. *Proc Natl Acad Sci USA* 97(20):10701–10705
4. Boder ET, Wittrup KD (1997) Yeast surface display for screening combinatorial polypeptide libraries. *Nat Biotechnol* 15:553–557
5. Smith GP (1985) Filamentous fusion phage: novel expression vectors that display cloned antigens on the virion surface. *Science* 228(4705):1315–1317
6. Bradbury A et al (2003) Antibodies in proteomics I: generating antibodies. *Trends Biotechnol* 21(6):275–281
7. McCafferty J et al (1990) Phage antibodies: filamentous phage displaying antibody variable domains. *Nature* 348(6301):552–554
8. Hoogenboom HR et al (1991) Multi-subunit proteins on the surface of filamentous phage: methodologies for displaying antibody (Fab) heavy and light chains. *Nucleic Acids Res* 19(15):4133–4137
9. Sblattero D, Bradbury A (1998) A definitive set of oligonucleotide primers for amplifying human V regions. *Immunotechnology* 3(4):271–278

10. Vaughan TJ et al (1996) Human antibodies with sub-nanomolar affinities isolated from a large non-immunized phage display library [see comments]. *Nat Biotechnol* 14(3):309–314
11. Sblattero D, Bradbury A (2000) Exploiting recombination in single bacteria to make large phage antibody libraries. *Nat Biotechnol* 18(1):75–80
12. Hoogenboom HR, Winter G (1992) By-passing immunisation. Human antibodies from synthetic repertoires of germline VH gene segments rearranged in vitro. *J Mol Biol* 227(2):381–388
13. Sidhu SS, Kossiakoff AA (2007) Exploring and designing protein function with restricted diversity. *Curr Opin Chem Biol* 11(3):347–354
14. Fellouse FA et al (2007) High-throughput generation of synthetic antibodies from highly functional minimalist phage-displayed libraries. *J Mol Biol* 373(4):924–940
15. Krebs B et al (2001) High-throughput generation and engineering of recombinant human antibodies. *J Immunol Methods* 254(1–2):67–84
16. Bradbury A et al (2003) Antibodies in proteomics II: screening, high-throughput characterization and downstream applications. *Trends Biotechnol* 21(7):312–317
17. Di Niro R et al (2010) Rapid interactome profiling by massive sequencing. *Nucleic Acids Res* 38(9):e110
18. Lim TS et al (2010) V-gene amplification revisited—an optimised procedure for amplification of rearranged human antibody genes of different isotypes. *N Biotechnol* 27(2):108–117
19. Krebber A et al (1997) Reliable cloning of functional antibody variable domains from hybridomas and spleen cell repertoires employing a reengineered phage display system. *J Immunol Methods* 201:35–55
20. Yamamoto KR et al (1970) Rapid bacteriophage sedimentation in the presence of polyethylene glycol and its application to large-scale virus purification. *Virology* 40(3):734–744

Antigen-Specific In Vitro Immunization: A Source for Human Monoclonal Antibodies

Kosuke Tomimatsu and Sanetaka Shirahata

Abstract

Human monoclonal antibody has great potential for treatment of various diseases utilizing their specificity against antigens. We have shown an in vitro immunization (IVI) protocol inducing antigen-specific immune responses in human peripheral blood mononuclear cells (PBMCs) for efficient production of human monoclonal antibodies. By using IVI method antigen specific antibody genes can be efficiently obtained because of increasing production of antigen-specific antibodies from in vitro immunized PBMCs. This IVI protocol will be widely applied for combination with several display methods and enhance the production of human monoclonal antibodies.

Key words Human monoclonal antibody, In vitro immunization, Antigen specific antibody production, Antibody engineering

1 Introduction

Monoclonal antibodies are proteins that specifically and sensitively react with specific sites on target molecules. They have become important tools in modern biological research and have great clinical potential, particularly in the analysis and treatment of human disease. Production of monoclonal antibodies by using laboratory animals is relatively easy; however, their therapeutic efficacy is restricted by their antigenicity and rapid elicitation of a neutralizing anti-monoclonal antibody immune response in human patients. Thus, it is necessary to obtain fully human antibody to overcome the problem of antigenicity.

In the case of mouse monoclonal antibody, antigen injected intraperitoneally induces strong immune response. But in human, there are ethical limitations which necessitate establishment of in vitro methods to sensitize naïve lymphocytes by antigens of interest. For the selection of antigen specific human antibody genes in vitro, several display methods as phage [1, 2], bacterial [3], ribosomal and yeast [4] were developed and many researchers have

succeeded to produce entire human monoclonal antibodies by using these methods. The affinity of antibodies that can be isolated from naïve libraries is intrinsically linked to the library size. Indeed, for the isolation of monoclonal antibody with high affinity it is essential to construct an enormous size of library which requires considerable time and effort.

We have developed an *in vitro* immunization protocol to induce antigen specific immune responses in human PBMCs for efficient production of human monoclonal antibodies [5]. Using this protocol, B cells producing antigen specific antibody can be propagated within a week and it enable to isolate antigen specific antibody genes from relative small scale library by combined with several display methods.

2 Materials

2.1 Preparation of Human Peripheral Blood Mononuclear Cells

1. Culture medium for PBMCs: Enhanced RDF (RPMI1640: DMEM:Ham's F12 = 1:1:2) (eRDF) supplemented with 10 % heat-inactivated fetal bovine serum (FBS).
2. Lymphocyte separation medium (LSM) (Organon Teknika, Durham, NC).

2.2 In Vitro Immunization

1. Dishes for *in vitro* immunization (IVI): 48-well flat bottom multiwell plate.
2. Recombinant human interleukin 2 (IL-2).
3. Recombinant human interleukin 4 (IL-4).
4. 2-mercaptoethanol.
5. L-leucyl-L-leucine methyl ester (LLME).
6. CpG Oligodeoxynucleotide (ODN):
D-type CpG ODN (5'-ggTGCATCGATGCAGGGGggG-3')*.
K-type CpG ODN (5'-tcgagcgttctcC-3')*.
*Capital and small letters indicate bases with phosphodiester and phosphorothioate-modified backbones respectively.
7. Phosphate buffered saline (PBS).

2.3 Enzyme Linked Immunospot Assay

1. Multiscreen HA filter plates.
2. Fish gelatin (FG).
3. PBS containing 0.05 % Tween 20 (PBST).
4. 0.5 M sodium carbonate buffer (pH 9.6).
5. Anti-human IgM antibody conjugated with horse radish peroxidase (HRP).
6. True Blue substrate solution (KPL, Gaithersburg, MD).
7. Melipunch (Millipore).

2.4 Enzyme Linked Immunosorbent Assay

1. 96-well microtiter enzyme linked immunosorbent assay (ELISA) plate.
2. Anti-human IgM.
3. Anti-human IgG.
4. Anti-human IgM conjugated with HRP.
5. Anti-human IgG conjugated with HRP.
6. Substrate solution: 0.1 M citrate buffer containing 0.003 % H₂O₂ and 0.3 mg/ml 2,2'-azido-bis (3-ethylbenzothiazoline-6-sulfonic acid) diammonium salt (ABTS).

2.5 Acquisition of Antibody Genes from In Vitro Immunized PBMCs

1. GenElute™ Total RNA Miniprep kit.
2. M-MLV Reverse transcriptase.
3. Oligo(dT)₂₀ primer.
4. DECP-treated water.
5. KOD-Plus- (Toyobo).
6. DNA size marker.
7. Sterile tips and PCR tubes.

3 Methods

The following procedure describes an in vitro immunization method to induce antigen specific antibody producing B lymphocytes for efficient acquisition of human antibody genes. The method makes bias of genetic diversity against the target antigen on the obtained antibody genes.

3.1 Preparation of Human Peripheral Blood Mononuclear Cells

Human PBMCs are separated by density-gradient centrifugation from several healthy donors. All experiments in this protocol should be carried out in accordance with the principles of the Declaration of Helsinki and the regulations of the Ethics Committee.

1. Human peripheral blood is collected from healthy donor. Start preparation of PBMCs from 100 ml of peripheral blood at a time.
2. Dilute blood 1:1 with calcium-magnesium-free PBS. Add 25 ml of the peripheral blood into 50 ml tube with 25 ml of PBS.
3. Mix thoroughly by inverting.
4. Add carefully 25 ml of the diluted peripheral blood on 15 ml of LSM solution in 50 ml tube (*see Note 1*). Use a clear plastic centrifuge tube.
5. Centrifuge at $400 \times g$ for 30 min.

6. Carefully collect the band including lymphocytes on LSM and transfer to a new 50 ml tube with 20 ml of 10 % FBS/ERDF medium (*see Note 2*).
7. Fill up to 45 ml with 10 % FBS/ERDF.
8. Centrifuge at $400\times g$ for 30 min.
9. Discard supernatant and resuspend pellet in 5 ml of 10 % FBS/ERDF and transfer to a 15 ml tube.
10. Count nucleated cells with either a hemocytometer or an electronic counting device.
11. Add 9 ml of 10 % FBS/ERDF and centrifuge at $400\times g$ for 7 min.
12. Go to Subheading 3.2 (*see Note 3*).

3.2 In Vitro Immunization

PBMCs are strongly suppressed by immunosuppressive cells, including NK cells and monocytes: no sensitization to antigens occurs if one uses PBMCs directly isolated from human blood. Treatment of PBMCs with L-leucyl-L-leucine methyl ester (LLME) removes these immunosuppressive cells and thus enables the in vitro sensitization with any antigen [6–8]. Then, LLME treated cells are immunized with antigens in the presence of cytokines (IL-2, IL-4), D-type and K-type CpG-ODN and subsequent tissue culture for a week in 48-well plate. Compared to the control, PBMCs immunized in vitro demonstrate an augmentation of cell to cell interactions and consequently numerous larger cluster formations, increased expression of antibody genes, increased total antibody productions, and induced antigen-specific antibody producing cells (Fig. 1).

1. Dilute the prepared PBMC pellet with 10 % FBS/ERDF supplemented with 0.25 mM LLME and adjust cell density to 1×10^7 cells/ml.
2. Incubate cells for 20 min at room temperature (*see Note 4*).
3. Centrifuge at $400\times g$ for 7 min.
4. Aspirate off supernatant.
5. Resuspend with 10 % FBS/ERDF and centrifuge at $400\times g$ for 7 min.
6. Aspirate off supernatant.
7. Resuspend with 10 % FBS/ERDF and centrifuge at $400\times g$ for 7 min.
8. Aspirate off supernatant.
9. Resuspend PBMCs with 10 % FBS/ERDF supplemented with 50 mM. 2-mercaptoethanol, 1 mM D-type CpG, IL-2, and IL-4 (*see Note 5*) and transfer to 48-well plate at $0.5\text{--}1.0\times 10^7$ cells/500 μl per well.

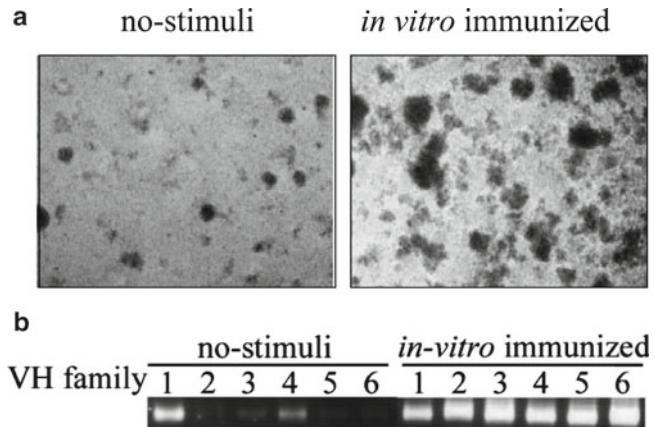

Fig. 1 Augmented responses of PBMCs by in vitro immunization. LLME-treated PBMCs were sensitized with antigen in ERDF medium supplemented with 10 % FBS, IL-2, IL-4, CpG-ODN. (a) Cluster formation. After 7 days in tissue culture, clusters of PBMCs are observed under a phase contrast microscope. (b) Amplification of VH genes derived from in vitro antigen-stimulated PBMCs. After 7 days of culture, total RNA, isolated from antigen-sensitized and control PBMCs, was used to synthesize cDNA. The VH genes were amplified by PCR using family-specific primers

10. Add a specific antigen dissolved in PBS (*see Note 6*).
11. Leave in tissue culture for 3 days at 37 °C.
12. Add K-type CpG to a final concentration of 1 mM.
13. Culture for 4 days at 37 °C.
14. Collect cells with their tissue culture medium into 1.5 ml tube.
15. Centrifuge in a microfuge $3,400 \times g$ 1 min. The cells in the pellet are used for enzyme linked immunospot assay (ELISpot) analysis and for the acquisition of antibody genes by PCR whereas the culture supernatant is used for analysis of antibody production by ELISA.

3.3 Enzyme Linked Immunospot Assay

This method provides effective measurement of antigen-specific antibody production from in vitro stimulated cells on single cell level (Fig. 2). After 7 days of immunization, cells are collected and tested for their immune response against the specific antigen used for immunization. The in vitro immunized cells are cultured on an immunospot plate coated by several relevant antigens. Secreted antibodies that recognize antigen are detected by a secondary antibody.

1. Coat Multiscreen HA filter plate with the relevant antigen in 100 μ l of 0.5 M carbonate buffer and incubate overnight at room temperature.
2. Wash three times with PBS.

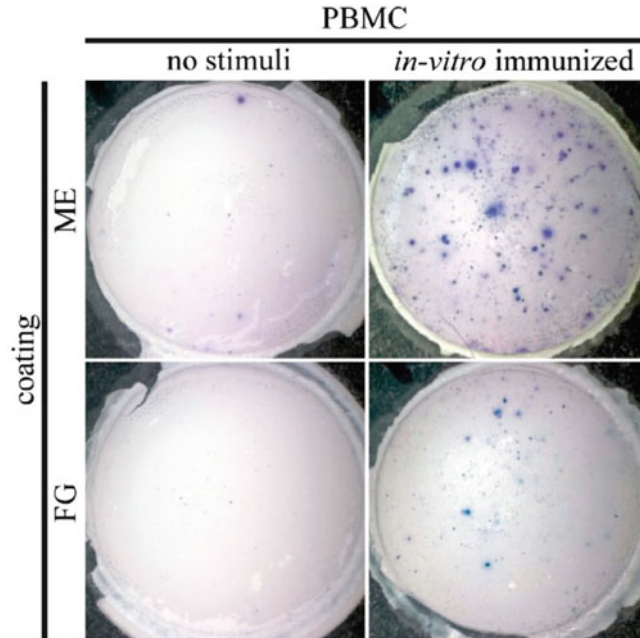

Fig. 2 ELISpot analysis of in vitro antigen immunized PBMCs. LLME-treated PBMCs were sensitized with antigen (Mite Extract, ME) in ERDF medium supplemented with 10 % FBS, IL-2, IL-4, CpG-ODN or cultured in ERDF medium supplemented with 10 % FBS only (as control) for 6 days. The PBMCs were transferred into Multiscreen HA plates coated with FG or ME. B cells secreting antigen-specific antibody were detected as *blue spots* (Color figure online)

3. Block the plate by adding 300 μ l of 1 % fish gelatin in PBS.
4. Incubate for 2 h at 37 $^{\circ}$ C.
5. Wash three times with PBS.
6. Add in vitro immunized-PBMCs in eRDF medium supplemented with 10 % FBS and cytokines (the same conditions as described for in vitro immunization) to the plate, in triplicates, at 1×10^5 cells per well and incubate for 24 h in a humidified atmosphere at 37 $^{\circ}$ C and 5 % CO_2 . During the incubation the cells will secrete antibodies, which will bind to the coated antigen.
7. Wash three times with PBST.
8. Add 10,000-fold diluted goat anti-human IgM antibody conjugated with horse radish peroxidase and incubate for 2 h at 37 $^{\circ}$ C.
9. Wash three times with PBST.
10. Add 50 μ l of TrueBlue substrate solution per well.
11. Incubate for 10 min at 37 $^{\circ}$ C.
12. Wash the plate in distilled water to stop the color reaction.

13. Dry the plate completely in the dark.
14. Punch out these membranes from the ELISpot plate to a sealing tape on the blue ELISpot transfer pad.
15. Count the number of spots using the ImageJ software.

3.4 Enzyme Linked Immunosorbent Assay

The ELISA is used for the detection and quantification of antibodies secreted from PBMCs.

1. Coat the wells of 96-well microtiter ELISA plate with 100 μ l of 1,000-fold diluted anti-human IgM or anti-human IgG antibody in carbonate buffer and incubate for 2 h at 37 °C.
2. Wash three times with PBST (*see Note 7*).
3. Block the plate by adding 300 μ l of 1 % fish gelatin in PBS.
4. Incubate for 2 h at 37 °C.
5. Wash three times with PBST.
6. Prepare serially diluted human IgM or IgG standards.
7. Add 50 μ l of appropriately diluted supernatants of in vitro immunized PBMCs to each well. In parallel, perform an ELISA with the diluted IgM or IgG standards.
8. Incubate for 2 h at 37 °C.
9. Wash three times with PBST.
10. Add 100 μ l of 2,000-fold diluted anti-human IgM or anti-human IgG antibody conjugated with HRP in 1 % FG PBS and incubate for 2 h at 37 °C.
11. Wash three times with PBST.
12. Add 100 μ l of ABTS substrate solution per well with a multi-channel pipette and incubate for 20 min at 37 °C.
13. Measure the absorbance at 405 nm using an ELISA reader.

3.5 Acquisition of Antibody Genes from In Vitro Immunized PBMCs

Total RNA from the in vitro immunized PBMCs is extracted using the RNA Extraction Kit. It is used as a template for the cDNA synthesis reaction with M-MLV reverse transcriptase.

3.5.1 cDNA Synthesis

1. Collect in vitro immunized PBMCs by centrifugation.
2. Resuspend the cell pellet in 250 μ l of lysis solution including 2-mercaptoethanol.
3. Transfer lysate to GenElute filtration column and centrifuge.
4. Add 250 μ l 70 % ethanol to the filtrate and mix thoroughly.
5. Transfer to binding column and centrifuge.
6. Discard flow through.
7. Add 500 μ l Wash solution 1 to the column and centrifuge.
8. Transfer column to a new collection tube.

9. Add 500 μl of Wash solution 2 to column and centrifuge.
10. Discard flow through.
11. Add 500 μl of Wash solution 2 to column and centrifuge for 2 min to remove ethanol.
12. Transfer column to a new collection tube.
13. Add 50 μl elution solution to the column and centrifuge.
14. Use eluate for RT-PCR.
15. Measure the absorbance at 260 and 280 nm using a spectrophotometer.
16. Add the following components to a nuclease-free microcentrifuge tube: 1 μg total RNA, 0.5 μg oligo (dT)₂₀ primer (50 μM), and DECP-treated water to 14 μl final volume.
17. Incubate at 65 °C for 10 min and then quickly chill on ice.
18. Add the following components to the reaction tube: 1.25 μl 10 mM dNTPs, 5 μl 5 \times concentrated reaction buffer, 4.25 μl DECP-treated water, and 0.5 μl M-MLV reverse transcriptase, and mix by gentle pipetting.
19. Incubate at 37 °C for 50 min.
20. Inactivate the reaction by heating at 70 °C for 15 min.

3.6 PCR

1. Add the following components to a PCR reaction tube: 5 μl 10 \times concentrated PCR Buffer for KOD-Plus-, 5 μl of 2 mM dNTPs, 2 μl 25 mM MgSO₄, 3 μl sense primer (10 μM), 3 μl anti-sense primer (10 μM), 1 μl KOD-Plus-, and distilled water to 50 μl final volume. Table 1 provides the information for the primers.
2. Place the reaction tubes on thermal cycler and follow the indicated protocol of temperatures and incubation times. First, initial denaturalization cycle at 94 °C. Then repeat 30 cycles the following program: Denature at 94 °C, 15 s, annealing at 60 °C, 30 s and extension at 68 °C, 1 min. The last step is a final elongation cycle at 72 °C, 5 min.
3. Add 5 μl 10 \times concentrated loading dye.
4. Load into the agarose gel slot and perform electrophoresis.
5. Visualize with UV illumination. If the amplified PCR products align with the expected size, then they can be used as specific reagents in the phage display method.

4 Notes

1. Layer diluted blood onto LSM carefully so that a sharp blood-LSM interface is created. Avoid mixing diluted blood into the LSM.

Table 1
Oligonucleotide primers used for amplification of the human immunoglobulin gene

Name	Sequence
Human VH back primers	
HuVH1BACK	5'-CAGGTSCAGCTGGTRCAGTC-3'
HuVH2BACK	5'-CAGRTCACCTTGAAGGAGTC-3'
HuVH3BACK	5'-SAGGTGCAGCTGGTGGAGTC-3'
HuVH4BACK	5'-CAGGTGCAGCTGCAGGAGTC-3'
HuVH5BACK	5'-GARGTGCAGCTGGTGCAGTC-3'
HuVH6BACK	5'-CAGGTACAGCTGCAGCAGTC-3'
Human JH forward primers	
HuJH1-2FOR	5'-TGAGGAGACGGTGACCAGGGTGCC-3'
HuJH3FOR	5'-TGAAGAGACGGTGACCATTGTCCC-3'
HuJH4-5FOR	5'-TGAGGAGACGGTGACCAGGGTTCC-3'
HuJH6FOR	5'-TGAGGAGACGGTGACCGTGGTCCC-3'
Human Vk back primers	
HuVk1BACK	5'-GMCATCCRGWTGACCCAGTCT-3'
HuVk2BACK	5'-GATRTGTGATGACYCAGTCT-3'
HuVk3BACK	5'-GAAATWGTGWTGACRCAGTCT-3'
HuVk4BACK	5'-GACATCGTGATGACCCAGTCT-3'
HuVk5BACK	5'-GAAACGACACTCACGCAGTCT-3'
HuVk6BACK	5'-GAAATTGTGCTGACTCAGTCT-3'
Human Jk forward primers	
HuJk1FOR	5'-ACGTTTGATTTCCACCTTGGTCCC-3'
HuJk2FOR	5'-ACGTTTGATCTCCAGCTTGGTCCC-3'
HuJk3FOR	5'-ACGTTTGATATCCACTTTGGTCCC-3'
HuJk4FOR	5'-ACGTTTGATCTCCACCTTGGTCCC-3'
HuJk5FOR	5'-ACGTTTAATCTCCAGTCGTGTCCC-3'
Human VI back primers	
HuVI1BACK	5'-CAGTCTGTGTTGACGCAGCCGCC-3'
HuVI2BACK	5'-CAGTCTGCCCTGACTCAGCCTGC-3'
HuVI3aBACK	5'-TCCTATGTGCTGACTCAGCCACC-3'
HuVI3bBACK	5'-TCTTCTGAGCTGACTCAGGACCC-3'
HuVI4BACK	5'-CACGTTATACTGACTCAACCGCC-3'
HuVI5BACK	5'-CAGGCTGTGCTCACTCAGCCGTC-3'
HuVI6BACK	5'-AATTTTATGCTGACTCAGCCCCA-3'
Human JI forward primers	
HuJI1FOR	5'-ACCTAGGACGGTGACCTTGGTCCC-3'
HuJI2-3FOR	5'-ACCTAGGACGGTCAGCTTGGTCCC-3'
HuJI4FOR	5'-ACCTAAAACGGTGAGCTGGGTCCC-3'

M: A or C; *R*: A or G; *S*: C or G; *W*: A or T; *Y*: C or T

2. Carefully collect white band on LSM not to suck LSM. It is recommended to use a Pipette aid-attached Pasteur pipette.
3. If the procedure cannot be carried out continuously, then dilute the PBMCs pellet with 10 % FBS/ERDF, adjusting cell density to 1×10^7 cells/ml and leave at 37 °C. However, cells should be used as soon as possible.
4. Invert the 15 ml tube every 5 min during LLME treatment.
5. Efficient induction of immune responses in vitro requires a fine tuning of the appropriate conditions of the cytokines. The balance of concentrations of IL-2 and IL-4 and individual difference related to the donors of PBMCs affect the immune responses in vitro [9]. According to our experience, 1–50 U/ml and 1–50 ng/ml are the appropriate concentrations for IL-2 and IL-4, respectively.
6. We confirmed the method for various antigens.
 - (a) Soluble proteins dissolved in PBS can be used directly as sensitizing antigen [10].
 - (b) Antibodies against cell-surface antigens, such as cell-receptors, will probably play an increasingly important role in the clinic. However, in vitro generation of antibodies against cell-surface antigens is difficult owing to the difficulty in preparation of sufficient amounts of antigen at high purity and in their native conformation. We therefore used whole cell which express target protein on the cell-surface as a sensitizing antigen. We focused on the high affinity IgE receptor epsilon alpha chain (FcεRIα) that triggers allergic reactions and which is expressed on human basophile cell line KU812F. The cells were fixed with 1 % glutaraldehyde on a fish gelatin-coated 48-well plate. The wells were gently washed three times and then LLME-treated PBMCs were added to the wells and cultured for a week. We succeed to induce KU812F cell specific immune response in vitro and to produce an anti-FcεRIα specific human monoclonal antibody [11].
 - (c) Cytokines, used as antigen for the stimulation of PBMCs might interfere with the cellular milieu of in vitro immunization. We failed to produce specific antibodies when TNF-α protein. In contrast, peptide derived from the TNF-α protein induced specific B cells that produced antibodies against the TNF-α protein. These results suggest that anti-cytokine antibodies can be engendered by using protein-derived peptides as sensitizing antigen in the in vitro immunization system [12].
7. In the procedure of ELISA, the wells are emptied by flicking the plate over a sink. The remaining drops are removed by patting the plate on a paper towel.

References

1. McCafferty J, Griffiths AD, Winter G, Chiswell DJ (1990) Phage antibodies: filamentous phage displaying antibody variable domains. *Nature* 348:552–554
2. Clackson T, Hoogenboom HR, Griffiths AD, Winter G (1991) Making antibody fragments using phage display libraries. *Nature* 352:624–628
3. Mazor Y, Van BT, Mabry R, Iverson BL, Georgiou G (2007) Isolation of engineered, full-length antibodies from libraries expressed in *Escherichia coli*. *Nat Biotechnol* 5:563–565
4. Border ET, Witttrup KD (1997) Yeast surface display for screening combinatorial polypeptide libraries. *Nat Biotechnol* 15:553–557
5. Ichikawa A, Katakura Y, Teruya K, Hashizume S, Shirahata S (1999) In vitro immunization of human peripheral blood lymphocytes: establishment of B cell lines secreting IgM specific for cholera toxin B subunit from lymphocyte stimulated with IL-2 and IL-4. *Cytotechnology* 31:131–139
6. Thiele DL, Lipsky PE (1986) The immunosuppressive activity of L-leucyl-L-leucine methyl ester: selective ablation of cytotoxic lymphocytes and monocytes. *J Immunol* 136:1038–1048
7. Borrebaeck CA, Danielsson L, Moller SA (1987) Human monoclonal antibodies produced from L-leucin methyl ester treated and in vitro immunized peripheral blood lymphocytes. *Biochem Biophys Res Commun* 148:941–946
8. Mason PD, Weetman AP, Sissons JG, Borysiewicz LK (1988) Suppressive role of NK cells in pokeweed mitogen-induced immunoglobulin synthesis: effect of depletion/enrichment of Leu 11b⁺ cells. *Immunology* 65:113–118
9. Yamashita M, Katakura Y, Shim SY, Matsumoto SE, Tamura T, Morihara K, Aiba Y, Teruya K, Tsuchiya T, Shirahata S (2002) Different individual immune responses elicited by in vitro immunization. *Cytotechnology* 40:161–165
10. Matsumoto SE, Yamashita M, Katakura Y, Aiba Y, Tomimatsu K, Kabayama S, Teruya K, Shirahata S (2008) A rapid and efficient strategy to generate antigen-specific human monoclonal antibody by *in vitro* immunization and the phage display method. *J Immunol Methods* 332:2–9
11. Tomimatsu K, Matsumoto SE, Yamashita M, Teruya K, Katakura Y, Kabayama S, Shirahata S (2009) Production of human monoclonal antibodies against FcεRIα by a method combining *in vitro* immunization with phage display. *Biosci Biotechnol Biochem* 73:1465–1469
12. Tamura T, Tomimatsu K, Katakura Y, Yamashita M, Matsumoto SE, Aiba Y, Jung YS, Abe Y, Fujiki T, Teruya K, Shirahata S (2007) Anti-peptide antibody production elicited by in vitro immunization of human peripheral blood mononuclear cells. *Biosci Biotechnol Biochem* 71:2871–2875

Chapter 16

Methods for Radiolabelling of Monoclonal Antibodies

Vladimir Tolmachev, Anna Orlova, and Karl Andersson

Abstract

The use of radionuclide labels allows to study the pharmacokinetics of monoclonal antibodies, to control the specificity of their targeting and to monitor the response to an antibody treatment with high accuracy. Selection of label depends on the processing of an antibody after binding to an antigen, and on the character of information to be derived from the study (distribution of antibody in the extracellular space, target occupancy or determination of sites of metabolism). This chapter provides protocols for labelling of antibodies with iodine-125 (suitable also for other radioisotopes of iodine) and with indium-111. Since radiolabelling might damage and reduce the immunoreactive fraction and/or affinity of an antibody, the methods for assessment of these characteristics of an antibody are provided for control.

Key words Direct radioiodination, Indirect radioiodination, CHX-A'DTPA, Indium-111, Iodine-125, Immunoreactive fraction, Saturation assay, LigandTracer

1 Introduction

Following fate of antibodies in vivo can provide important information during preclinical development of antibody-based therapies, during clinical trials and, with the advent of personalized medicine, in daily clinical practice. The use of radioactive labels for antibodies facilitates such studies, because it is easy to quantify radioactivity concentration. Moreover, current imaging techniques, such as single photon emission computed tomography (SPECT) and positron emission tomography (PET), permit to visualize and quantify distribution of radioactivity in vivo by non-invasive procedures. Radiolabelled antibodies can be used during preclinical development for investigation of pharmacokinetics and targeting properties, dose finding and evaluation of response for treatment, hence speeding up the process of drug discovery. The dose finding can be facilitated in clinical trials, reducing the number of patients treated with suboptimal doses of antibodies. In addition, the radiolabeled antibodies can be used for selection of

patients who have tumors expressing a particular antigen and may benefit from particular therapy [1].

It has to be taken into account that labelling chemistry can influence cellular retention of radioactivity. Majority of antibodies are internalized after binding to cell-surface antigens, either by clathrin-dependent endocytosis or due to the normal turnover of cellular membrane constituents via non-clathrin-dependent endocytosis [2, 3]. After internalization and translocation into lysosomal compartment, antibodies are proteolytically degraded. In vitro studies have demonstrated that the fate of a radioactive label after proteolytic degradation depends on lipophilicity of radiocatabolites [4, 5]. Lipophilic radiocatabolites can diffuse through phospholipid lysosomal and cellular membranes, and leave the malignant cells. Such fate is typical for vast majority of radio-halogen labels [6]. If the radiocatabolites are bulky hydrophilic (e.g., charged) molecular moiety, they would be retained inside the cells before excretion by relatively slow externalization. The radio-labels, which are trapped inside the cells after internalization and degradation of targeting protein, are called “residualizing” or “trapped.” Radiometals are mainly residualizing labels [7] since their radiocatabolites are polar and often charged. Accordingly, different labels show different aspects of antibody distribution in vivo. Radioactivity associated with non-residualizing halogen labels reflects distribution of an antibody in blood, in extracellular space and bound to membranes of target cells or to extracellular matrix. Radioactivity associated with residualizing radiometal labels reflects, along with distribution of antibody outside cells, the amount of antibody, which has been internalized and degraded inside the tumor cells and by catabolizing organs. Combination of both residualizing and non-residualizing labels for the same antibody provides the most complete information concerning its fate in vivo. Resolving gamma-spectra of radiometal and radiohalogen labels, one can derive such information from a single biodistribution study, upon co-injection in the same animal of an antibody labelled in two different ways [8].

One has to be aware that radiolabelling can influence a binding capacity of an antibody. For example, an oxidative radioiodination of antibodies using Chloramine-T [9] is the most commonly used method due to its robustness and simplicity. Radioiodide is oxidized in situ with subsequent attack of nucleophilic side-chains of a protein. A predominant site of electrophilic iodination at physiological pH is tyrosine [10]. It was found [11, 12] that tyrosine residues are overrepresented in complementarity determining regions (CDR) of antibodies. Iodination of tyrosines in CDR might decrease antigen binding capacity of antibodies [12]. Lysines are presented in CDR to much lesser extent [13], and indirect halogenation, which is based on coupling of radiolabelled precursor to ω -amino groups of lysines, is often safer for proteins.

However, over-modification of lysines might be also unfavorable for binding capacity and biodistribution properties of radiolabelled antibodies. For this reason, one should take care that a number of pendant group (for radioiodination) or chelators (for radiometal labelling) should not exceed four to five per protein molecule. After labelling of an antibody, the functional properties of antibody binding should be quantified to verify that adequate binding and acceptable immunoreactive fraction (IRF) is retained. The minimum level of quality control is to verify that the labelled protein interacts with the intended target. Since the binding properties of the unlabelled protein may be unknown, the value produced by the binding assay may serve as a characteristic of the labelled product, which can be followed over time to prove consistent performance of the labelling protocol. The saturation assay, which estimates the equilibrium dissociation constant K_D is a representative binding assay that performs well for interactions that reach equilibrium within one to a few hours. Real-time interaction analysis is a novel and more precise method for quantifying details of the binding characteristics. It is advantageous for high-affinity interactions, and requires less work than the manual binding assays, but relies on access to specialized equipment.

Another aspect of labelling quality is the immunoreactive fraction, i.e., the fraction of the labelled product, which is capable of binding to the target. The Lindmo assay [14] is the most commonly used method for assessing immunoreactive fraction.

In this chapter, we provide a description of two methods of radioiodination [a direct radioiodination using Chloramine-T (Fig. 1a) and indirect radioiodination using *N*-succinimidyl 4-trimethylstannylbenzoate (Fig. 1b)] and labelling with ^{111}In using CHX-A''-DTPA (Fig. 1c). The most commonly used method for determination of affinity (saturation assay) and immunoreactive fraction (Lindmo analysis) of radiolabelled antibodies are also provided. In addition, a new method for determination of affinity of targeting proteins to living cells, LigandTracer analysis, is described. Besides an affinity value, this method provides information concerning association and dissociation kinetics of an antibody interaction.

^{125}I ($T_{1/2} = 60$ days) is the most commonly used radionuclide for preclinical studies (in vitro experiments, biodistribution in small rodents using direct ex vivo measurements, imaging in mice). This nuclide combines a long half-life with low radiation dose to personnel. The same protocol may be used for radioiodination using ^{131}I ($T_{1/2} = 8$ d) (e.g., for radionuclide therapy, or for dual-label biodistribution studies), ^{123}I ($T_{1/2} = 13.3$ h) (SPECT imaging) and ^{124}I ($T_{1/2} = 4.18$ d) (PET imaging). ^{111}In ($T_{1/2} = 2.8$ d) is a commercially available radiometal. Its half-life is compatible with bio-kinetics of intact IgG. ^{111}In is suitable for in vitro experiments, biodistribution in small rodents using direct ex vivo measurements, imaging in mice, as well as for clinical imaging using SPECT/CT (*see Note 1*).

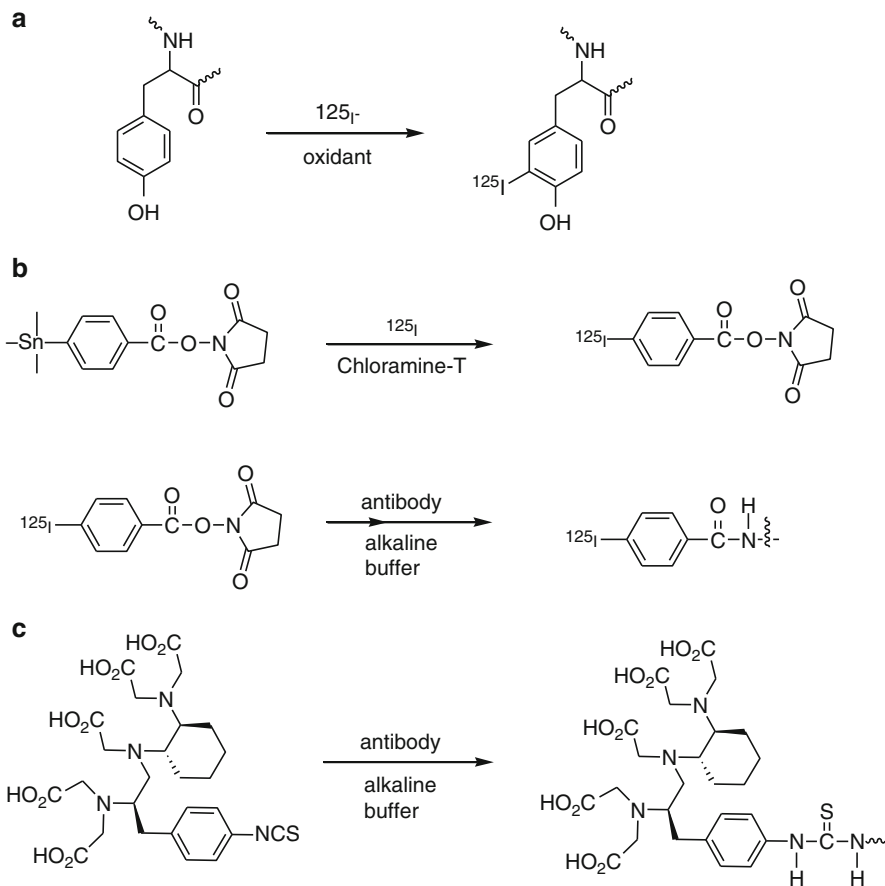

Fig. 1 Labelling of antibodies with ^{125}I by oxidative radioiodination using Chloramine-T (**a**), indirect radioiodination using *N*-succinimidyl 4-thrimethylstannylbenzoate (**b**)-Conjugation of CHX-A''-DTPA for labelling with ^{111}In (**c**)

2 Materials

2.1 Purification of an Antibody

1. Milli-Q/ELGA water.
2. NAP-5 column (GE Healthcare).
3. Eppendorf tubes (1.7 ml).
4. Antibody solution.
5. Automatic pipette 1 ml, pipette tips.
6. Lyophilizing machine (freeze dryer).

2.2 Direct Radioiodination of an Antibody with ^{125}I Using Chloramine-T

1. Milli-Q/ELGA water.
2. Electronic balance (0.1 mg).
3. Freeze-dried antibody.
4. NAP-5 column (GE Healthcare).

5. Eppendorf tubes (1.7 ml).
6. ^{125}I stock solution (GE Healthcare or PerkinElmer) (*see Note 1*).
7. Chloramine-T trihydrate, sodium chloro-(4-methylphenyl) sulfonylazanide (Sigma or Merck).
8. Sodium metabisulfite, $\text{Na}_2\text{S}_2\text{O}_5$ (Sigma or Merck).
9. Automatic pipette 5–50 μl , pipette tips.
10. Automatic pipette 1 ml, pipette tips.
11. 0.05 M phosphate buffered saline, pH 7.4 (PBS).
12. Timer.
13. Vortex mixer.
14. Dose calibrator set for ^{125}I .
15. Tec-Control Chromatography 150-771 strips (Biodex).
16. 70 % acetone/30 % water mixture.
17. PhosphorImager or TLC scanner (optional).

**2.3 Indirect
Radioiodination
of an Antibody Using
N-Succinimidyl
para-Iodobenzoate**

N-succinimidyl 4-(trimethylstannyl) benzoate can be synthesized according to method described by Kozirowski et al. [15].

1. Freeze-dried antibody.
2. ^{125}I stock solution (GE Healthcare or PerkinElmer) (*see Note 1*).
3. Siliconized Eppendorf tubes (1.7 ml).
4. 0.07 M sodium borate, pH 9.3.
5. *N*-succinimidyl 4-(trimethylstannyl) benzoate (ATE).
6. Chloramine-T trihydrate, sodium chloro-(4-methylphenyl) sulfonylazanide (Sigma or Merck).
7. Sodium metabisulfite, $\text{Na}_2\text{S}_2\text{O}_5$ (Sigma or Merck).
8. 0.1 % aqueous solution of acetic acid.
9. 5 % acetic acid in methanol.
10. Milli-Q/ELGA water.
11. Vortex mixer.
12. Timer.
13. NAP-5 column (GE Healthcare).
14. 0.05 M phosphate buffered saline, pH 7.4 (PBS).
15. Automatic pipette 1 ml, pipette tips.
16. Automatic pipette 2–50 μl , pipette tips.
17. Tec-Control Chromatography 150-771 strips (Biodex).
18. 70 % acetone/30 % water mixture.
19. TLC tank.
20. Dose calibrator set for ^{125}I .
21. PhosphorImager or TLC scanner (optional).

2.4 Labelling of an Antibody with ^{111}In Using CHX-A'' DTPA

1. Ion-exchange resin Chelex 100 in sodium form (Sigma).
2. Disposable 0.4 μm filters.
3. Disposable syringes.
4. Disposable polypropylene 20 ml vials.
5. Freeze-dried antibody.
6. Siliconized Eppendorf tubes (1.7 ml).
7. 0.07 M sodium borate, pH 9.3, stored over Chelex 100.
8. 0.2 M ammonium acetate, pH 5.5, stored over Chelex 100.
9. CHX-A''DTPA, *N*-[(*R*)-2-Amino-3-(*p*-isothiocyanato-phenyl)propyl]-*trans*-(*S,S*)-cyclohexane-1,2-diamine-*N,N,N'*,*N'',N''*-pentaacetic acid (Macrocyclics).
10. Vortex mixer.
11. Heating block providing 37 °C.
12. NAP-5 column (GE Healthcare).
13. Automatic pipette 1 ml, pipette tips.
14. Automatic pipette 2–50 μl , pipette tips.
15. ^{111}In chloride in 0.05 M hydrochloric acid for labelling of antibodies (*see* **Note 1**).
16. Tec-Control Chromatography 150-771 strips.
17. 0.2 M citric acid.
18. PhosphorImager or TLC scanner (optional).

2.5 Determination of Immunoreactive Fraction

1. Cells, adherent or in suspension, 4×10^7 cells.
2. Radiolabelled antibody.
3. Non-labelled antibody.
4. 0.05 M phosphate buffered saline, pH 7.4 (PBS).
5. Polypropylene centrifuge tubes, 15 ml.
6. Siliconized Eppendorf tubes.
7. Pipette controller (e.g., Pipetboy).
8. Glass or plastic pipettes, 10 ml.
9. Set of automatic pipettes 1 μl to 1 ml, pipette tips.
10. Cell scraper for adherent cells.
11. Vortex mixer.
12. Cell counter.
13. Centrifuge (at least $5,000 \times g$, with timer).
14. Gamma-counter.

2.6 Determination of Dissociation Constant/Saturation Assay

1. Cells, adherent.
2. Radiolabelled antibody.
3. Non-labelled antibody.

4. 0.05 M phosphate buffered saline, pH 7.4 (PBS).
5. Complete cultivation medium for the designated adherent cell line.
6. Trypsin–EDTA, 0.25 % trypsin, 0.02 % EDTA in buffer, or other appropriate buffer for cell detachment.
7. Polypropylene centrifuge tubes, 15 ml.
8. Disposable cell dishes or 24-well cell plates.
9. Siliconized Eppendorf tubes.
10. Disposable test tubes.
11. Vials for cell counting.
12. Pipette controller (e.g., Pipetboy).
13. Disposable plastic pipettes (10 ml).
14. Set of automatic pipettes 1 µl to 1 ml, pipette tips.
15. Vortex mixer.
16. Cell counter.
17. Gamma-counter.

2.7 LigandTracer

1. Adherent cells, expressing at least 30,000–50,000 antigen copies per cell.
2. Circular cell dish with 87 mm outer bottom diameter (e.g., Nunclon™ cat. No. 150350 or 172958 on www.nuncbrand.com).
3. Cell culture medium, approximately 50 ml.
4. Radiolabeled antibody, typically 3–30 µg (depends on the apparent affinity).
5. LigandTracer instrument suitable for the selected radiolabel (¹²⁵I: LigandTracer Grey, PET/SPECT radionuclides: LigandTracer Yellow).

3 Methods

3.1 Purification of an Antibody (see Note 1)

Purification of antibodies is essential for all conjugation labelling techniques. Most commonly, a conjugation of a chelator or a linker is directed to an amino group of a protein. Very often, antibody preparations contain free amino acids. The presence of free amino acids may interfere with amino-directed coupling.

1. Pre-equilibrate the NAP-5 column with Milli-Q water by passing 10 ml of Milli-Q water through the column.
2. Load 0.5 ml of the antibody solution on the column.
3. Collect and discard first 0.5 ml of eluate.
4. Add 1 ml of Milli-Q water to a column.

5. Collect eluate into an Eppendorf tube.
6. Freeze the eluate at $-18\text{ }^{\circ}\text{C}$ for at least 3 h.
7. Freeze-dry the eluate overnight.

**3.2 Direct
Radioiodination of an
Antibody with ^{125}I
Using Chloramine-T**

Important! The work should be performed in a well-ventilated fume-hood. Contamination control should be performed after labelling (*see Note 1*).

1. From the freeze-dried antibody, prepare a solution in PBS containing 2 mg/ml.
2. Prepare Eppendorf tubes containing 1–1.5 mg of Chloramine-T and sodium metabisulfite.
3. Before starting of labelling, pre-equilibrate a NAP-5 column with PBS, by passing at least 10 ml of the buffer through the column.
4. Prepare immediately before labelling a Chloramine-T solution in PBS (1 mg/ml) and sodium metabisulfite solution (2 mg/ml in PBS).
5. Place 10 μl ^{125}I stock solution into an Eppendorf tube (*Note:* Up to 20 μl of ^{125}I stock solution can be used according to this protocol).
6. Add 20 μl antibody solution (40 μg) to the ^{125}I solution.
7. Add 40 μl PBS to the mixture of ^{125}I and the antibody solution.
8. Add 15 μl of Chloramine-T solution in PBS to the mixture of ^{125}I and antibody. Vortex carefully and incubate the mixture for 60 s.
9. Add 15 μl sodium metabisulfite solution to the reaction mixture and vortex the mixture carefully. Calculate the mixture volume, $X\mu\text{l}$.
10. Load the reaction mixture on the NAP-5 column. Let it pass through the upper filter. Then add $(500 - X)\mu\text{l}$ PBS and let it pass through the upper filter.
11. Collect the eluate as a void volume fraction.
12. Add 1 ml PBS. Collect the eluate a high molecular weight fraction containing the labelled antibody.
13. Add 1.5 ml PBS. Collect the eluate a low molecular weight fraction.
14. Cap the column, start with the lower end to reduce the risk of contamination. Measure activity of empty reaction mixture vial, the high molecular weight fraction, the low molecular

weight fraction, and the column to calculate yield according to formula

$$\text{Yield} = \frac{[\text{activity of high molecular weight fraction}]}{[\text{sum of all measured activities}]}.$$

15. Take 1 μl sample of the high molecular weight fraction and place on Tec-Control Chromatography 150-771 strip. Elute the strip with the 70 % acetone/30 % water mixture.
16. Evaluate purity of the conjugate. The radiolabelled antibody would stay at the application point, while free ^{125}I would migrate with the solvent front. This might be done quantitatively using PhosphorImager or TLC scanner. Alternatively one can cut the Tec-Control Chromatography 150-771 in the middle. After measurement of background (B), measure radioactivity of half with the application point (A) and half with the solvent front (F). Calculate the purity according to formula

$$P(\%) = (A - B) \times 100 / (A + F - 2 \times B).$$

17. ^{125}I -antibody can typically be stored frozen at $-20\text{ }^{\circ}\text{C}$ for a few days.

3.3 Indirect Radioiodination of an Antibody Using N-Succinimidyl para-Iodobenzoate

Important! The work should be performed in a well-ventilated fume-hood. Contamination control should be performed after labelling.

1. Prepare an Eppendorf tube, containing approx. 1 mg antibody.
2. Prepare Eppendorf tubes containing 1–1.5 mg of Chloramine-T and sodium metabisulfite.
3. Prepare an Eppendorf tube containing 0.5–1 mg of *N*-succinimidyl 4-(trimethylstannyl) benzoate (ATE).
4. Immediately before labelling, dissolve the antibody in 0.07 M sodium borate, pH 9.3, to a concentration of 3 mg/ml.
5. Immediately before labelling, dissolve Chloramine-T in Milli-Q/ELGA water to a concentration of 4 mg/ml.
6. Immediately before labelling, dissolve sodium metabisulfite in Milli-Q water to a concentration of 8 mg/ml.
7. Immediately before labelling, dissolve ATE in 5 % acetic acid in methanol to a concentration of 1 mg/ml.
8. Place 4–10 μl ^{125}I stock solution into an Eppendorf tube.
9. Add 10 μl of 0.1 % aq. solution of acetic acid to ^{125}I .
10. Add 5 μl ATE-solution to the mixture. Vortex carefully.

11. Add 10 μl Chloramine-T solution to the mixture. Vortex carefully!
12. Incubate the mixture for 5 min at room temperature.
13. Add 10 μl sodium metabisulfite solution to the mixture. Vortex carefully.
14. Add 100 μl of the antibody solution to the mixture. Vortex carefully.
15. Incubate the mixture 60 min at room temperature. Calculate the mixture volume, $X\mu\text{l}$.
16. During incubation, pre-equilibrate a NAP-5 column with PBS (at least 10 ml).
17. Load the reaction mixture on the NAP-5 column and let it pass through the upper filter.
18. Add $(500 - X)$ μl PBS and let it pass through the upper filter.
19. Collect the eluate as a void volume.
20. Add 1 ml PBS. Collect the eluate a high molecular weight fraction containing the labelled antibody.
21. Add 1.5 ml PBS. Collect the eluate a low molecular weight fraction.
22. Cap the column, start with the lower end to reduce the risk of contamination. Measure activity of empty reaction mixture vial, the high molecular weight fraction, the low molecular weight fraction and the column to calculate yield according to formula

$$\text{Yield} = \frac{[\text{activity of high molecular weight fraction}]}{[\text{sum of all measured activities}].}$$

23. Take 1 μl sample of the high molecular weight fraction and place on Tec-Control Chromatography 150-771 strip. Elute the strip with the 70 % acetone/30 % water mixture.
24. Evaluate purity of the conjugate using the Tec-Control strips, as it has been described in Subheading 3.2, step 16. The radio-labeled antibody would stay at the application point, while free ^{125}I and ^{125}I -iodobenzoic acid would migrate with the solvent front.

3.4 Labelling of Antibody with ^{111}In Using CHX-A" DTPA

3.4.1 Preparation of Metal-Free Buffers (See Note 2)

1. Prepare 0.07 M sodium borate, pH 9.3, and 0.2 M ammonium acetate, pH 5.5, using a high-quality water and p.a. reagents.
2. Add Chelex 100 (10 g/l of buffer), mix carefully and let stay overnight.
3. Immediately before use, filter the buffer through a 0.4 μm filter into a disposable polypropylene vial. Use first 5 ml to rinse vials.

3.4.2 *Conjugation of CHX-A''DTPA to an Antibody*

1. Collect in an Eppendorf tube ~1.4 mg freeze-dried antibody. Note the exact weight.
2. Calculate required amount of CHX-A''DTPA. For a coupling of four chelator per an antibody molecule, 0.0188 μg CHX-A''DTPA per 1 μg of antibody is required.
3. Take in an Eppendorf tube 0.7–1.2 mg CHX-A''DTPA. Note the exact weight.
4. Dissolve CHX-A''DTPA in 0.07 M sodium borate, pH 9.3, to obtain a final concentration of 1 mg/ml. Use sonication if reagents dissolves slowly.
5. Add a calculated amount of CHX-A''DTPA in 0.07 M sodium borate, pH 9.3, to the antibody powder.
6. Add 200 μl of 0.07 M sodium borate, pH 9.3. Vortex the mixture carefully! Calculate the volume of the solution, $X\mu\text{l}$.
7. Incubate the reaction mixture for at least 4 h (preferably overnight) at 37 °C.
8. Pre-equilibrate a NAP-5 column with 0.2 M ammonium acetate, pH 5.5, stored over Chelex 100, by passing at least 10 ml of the buffer through the column.
9. Load the reaction mixture on the column. Let it pass through the upper filter.
10. Add $(500 - X)$ μl of 0.2 M ammonium acetate, pH 5.5.
11. Collect and discard the eluate.
12. Add 900 μl of 0.2 M ammonium acetate, pH 5.5, to the column, collect the eluate.
13. You can consider that all your antibody is eluted in 900 μl . Calculate the antibody concentration.
14. Divide the eluate, containing CHX-A''DTPA-antibody into aliquots containing 100 μg of antibody. The aliquots can be stored frozen at -20 °C.

3.4.3 *Labelling of CHX-A''DTPA antibody with ^{111}In*

1. Calculate a volume of ^{111}In stock solution required for approx. 10 MBq.
2. Add a required volume of ^{111}In to an aliquot of CHX-A''DTPA-antibody conjugate in 0.2 M ammonium acetate, pH 5.5 (100 μg).
3. Vortex the mixture carefully and incubate at room temperature for 1 h.
4. Take 1 μl sample and place on Tec-Control Chromatography 150-771 strip. Elute the strip with 0.2 M citric acid.
5. Evaluate purity of the conjugate as described in Subheading 3.2, **step 16**. The radiolabelled antibody would stay at the application point, while free ^{111}In would migrate with the solvent front.

6. If the purity of ^{111}In —labelled antibody is over 95 %, dilute the mixture with PBS to 1 ml. If the purity is below 95 %, purify the conjugate using NAP-5 column according to manufacturer's instructions.
7. ^{111}In —labelled antibody can be stored frozen at $-20\text{ }^{\circ}\text{C}$ for a few days.

3.5 Determination of Immunoreactive Fraction

This protocol was established in our laboratories based on the methodology described by Lindmo and coworkers [14]. We refer readers interested in the theoretical background of the method to that publication *see* **Notes 3–5**.

1. Calculate a volume of a labelled antibody to prepare 15 ml solution with concentration of $20 \times K_D$ (where K_D is an apparent dissociation constant of non-labelled antibody at equilibrium). If K_D is not known, assume that $K_D = 30\text{ nM}$.
2. Calculate an amount of non-labelled antibody to prepare 1.1 ml solution with concentration $1,000 \times K_D$.
3. Adherent cells: Scrape cells and resuspend them in PBS by pipetting.
4. Count cells to assess cell concentration per milliliter.
5. Prepare four Eppendorf tubes, each with a cell pellet containing 10^7 cells in 1 ml by gentle centrifugation. Start with 15 ml centrifuge tubes if needed.
6. Put cell samples on ice or move them to a cold room ($4\text{ }^{\circ}\text{C}$).
7. Prepare a 1.1 ml aliquot of the non-labelled antibody in a polypropylene centrifuge tube, mark it, vortex gently.
8. Add 1 ml of the non-labelled antibody solution to one of the Eppendorf tubes with a cell pellet and resuspend the cells.
9. Add 1 ml PBS to other three tubes with cell pellets and resuspend the cells.
10. Prepare from each Eppendorf tube a series of 5–6 cell samples (0.5 ml) by consecutive dilutions by 1:2 in PBS, leave 0.5 ml cell suspension in the last series sample, mark samples.
11. Prepare a 15 ml aliquot of the labelled antibody in a polypropylene centrifuge tube, mark the tube, vortex gently.
12. Add 0.5 ml of the labelled antibody to each vial containing cells.
13. Incubate the cells with the radiolabelled antibody at $4\text{ }^{\circ}\text{C}$ for at least 4 h.
14. Form cell pellets by centrifugation (at least $5,000 \times g$ for 5 min).
15. Take 0.5 ml of supernatant from each Eppendorf tube to empty Eppendorf tube, mark the tubes.
16. Measure radioactivity content in samples.

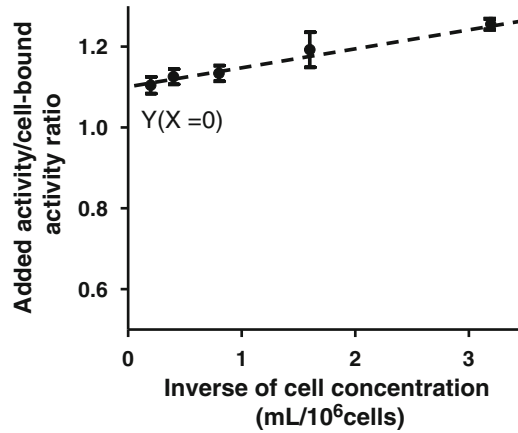

Fig. 2 Ratio of total added radioactivity to cell bound radioactivity as a function of inverse cell concentration. The immunoreactive fraction is calculated as $1/\gamma(X=0)$

17. Measure the background radioactivity of the sample holders used for radioactivity measurement.
18. Subtract the background radioactivity to obtain a background-corrected value for each supernatant and each pellet.
19. Calculate cell associated radioactivity $A(\text{cells})$ according to

$$A(\text{cells}) = \frac{A(\text{pellet} + \text{supernatant})}{A(\text{pellet} + \text{supernatant}) + A(\text{supernatant})}$$

20. For each data point, subtract unspecific binding ($A(\text{cells})$) values for samples incubated with non-labelled antibody).
21. Calculate for each data point.

$$\gamma = \frac{A(\text{pellet} + \text{supernatant}) + A(\text{supernatant})}{A(\text{cells})}$$

22. Calculate to each data point inverse cell concentration.

$$X = \frac{\text{ml}}{\text{Ig}(\text{cells in sample})}$$

23. Plot a graph of ratio of total added radioactivity to cell bound radioactivity as a function of inverse cell concentration (ml/cells) and extrapolate the line to interception with γ axes ($X=0$) (Fig. 2). We recommend using appropriate program for calculation (e.g., GraphPad Prizm, GraphPad Software Inc).
24. Calculate Immunoreactive fraction as $\text{IRF} = 100\% \times 1/\gamma(X=0)$.

3.6 Determination of Dissociation Constant/Saturation Assay

1. Prepare a set of four cell culture dishes with adherent antigen-expressing cells per concentration used, typically 32–48 dishes (triplicate plus one cell culture dish for determination of nonspecific binding by antigen blocking). Seed cells in advance, taking in account cells character (doubling time, receptor expression, time to stable attachment, etc.).
2. Calculate the labelled antibody concentrations (8–12 data points) starting from $0.2 \times K_D$ to $20 \times K_D$ (where K_D is an apparent dissociation constant of non-labelled antibody at equilibrium). If K_D value is unknown, we recommend a concentration range of 200 pM to 100 nM. Remember that actual concentration added to cell samples will be twice lower! *see Notes 6 and 7.*
3. Calculate dilution conditions for designed antibody concentrations, typically 1:3 (at least 3 ml solution for every is unknown concentration).
4. Calculate the amount of non-labelled protein required to prepare 7 ml solution with concentration $60 \times K_D$. If $K_D = 30$ nM.
5. Prepare solution of non-labelled antibody in PBS (in a polypropylene centrifuge tube, 15 ml), mark, and vortex gently.
6. Prepare solution of the labelled antibody in PBS (in a polypropylene centrifuge tube, 15 ml), mark the tube, and vortex gently.
7. Prepare a dilution series of labelled antibody solutions according to calculations using PBS, mark vials, vortex.
8. Wash cells with fresh media.
9. Put culture dishes with cells on ice or move them to cold room (4 °C).
10. Add 500 µl of non-labelled antibody solution to one of cell dishes for every data point, mark. Antigens in this dish will be close to saturated, and the majority of antibody binding will be unspecific. This dish will be designated as an unspecific binding control sample.
11. Add 500 µl PBS to all other cell culture dishes.
12. Add 500 µl of the labelled antibody solution with the lowest concentration to cell culture dishes (triplicate samples plus an unspecific binding control sample) and mark dishes.
13. Take one standard sample (500 µl) to a test tube and mark tube.
14. Repeat these two (**steps 12 and 13**) steps for every concentration.
15. Incubate cell samples at 4 °C for 4 h.
16. After incubation, aspirate the radioactive solution, wash cells with fresh PBS, detach cells with 0.5 ml trypsin-EDTA

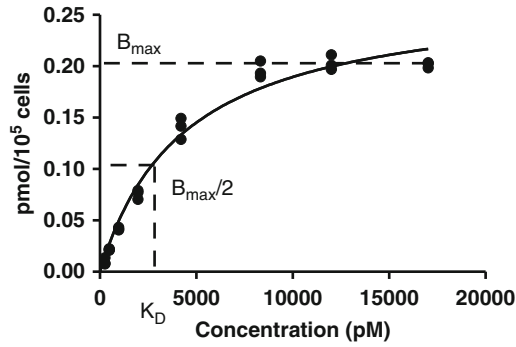

Fig. 3 Graphical determination of K_D (apparent dissociation constant of non-labelled antibody at equilibrium) for a radiolabelled antibody

solution (or other reagent), add 1 ml PBS, resuspend cells, take 0.5 ml for cell counting, collect the rest of cell suspension to test tubes for measurement, and mark test tubes with radioactive samples.

17. Count cells in all samples.
18. Measure radioactivity in all cell samples and the concentration standards.
19. Measure background radioactivity in the sample holders.
20. Subtract background radioactivity for each sample to obtain background-corrected values.
21. Calculate the real added radiolabelled antibody concentrations for each data point assuming that the highest concentration as the most reliable one (minimum losses due to protein absorption).
22. Calculate measured radioactivity for the highest concentration of added radiolabelled antibody as counts per minute (CPM) per pmol.
23. Calculate bound radioactivity per cell for every sample (e.g., CPM/10⁶ cells).
24. Subtract unspecifically bound radioactivity (radioactivity of the unspecific binding control sample for this data point) and obtain specifically bound radioactivity for every data point.
25. Calculate specifically bound radioactivity as pmol/10⁶ cells for every sample.
26. Plot a graph specifically bound radioactivity per cell (pmol/10⁶ cells) vs. concentration (pM). Determine B_{max} (maximum number of binding sites per cell) and calculate K_D as a concentration of radiolabelled antibody causing binding equal to $B_{max}/2$ (Fig. 3). We recommend using an appropriate software (e.g., GraphPad Prism, GraphPad Software Inc.) *see* **Notes 8 and 9**.

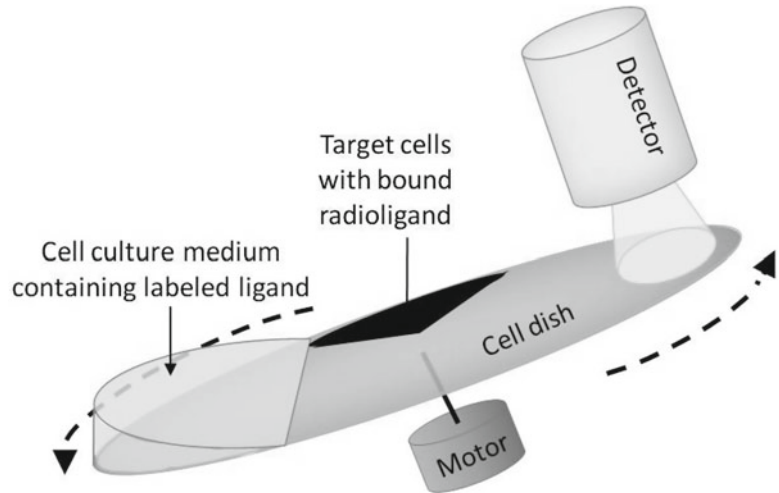

Fig. 4 Schematic illustration of LigandTracer technology

3.7 Determination of Dissociation Constant Using LigandTracer

LigandTracer technology has been described in a series of papers and the technical details of how to successfully conduct a real-time binding assay on living cells has been discussed elsewhere [16, 17]. Read the instrument instruction booklet prior to starting—standard operating procedures for maintaining and operating the instrument are clearly described there.

In brief, LigandTracer technology relies on a circular cell dish containing adherent cell in a limited portions, where the dish is placed on a tilted, slowly rotating support (Fig. 4). The radioactivity detector is placed over the elevated portion of the dish and registers the additional radioactivity brought under the detector by the cells. Hence, if the radiolabelled antibody binds to the cells, the detector will register an increased signal when the cells are below the detector than when the cells are out-of-view. Since the dish rotates continuously, approximately one data point per minute is collected, making it possible to follow the progress of the interaction over time.

3.7.1 Cell Dish Preparations

1. Take an 87 mm cell dish and place it tilted on some object (a cell dish lid is usually fine).
2. Carefully dispense 1–2 ml of cell culture medium containing ~1 million adherent cells into the lower part.
3. Place in an incubator (still tilted) and let the cells attach firmly. This typically takes 8 h, but it is strongly dependant on the cell line.
4. When the cells have attached, aspirate the medium, place the dish horizontally, add ~10 ml of cell culture medium, and culture the cells for at least 24 h before using the dish.

3.7.2 Antibody Binding Measurement

1. Place the dish in the appropriate LigandTracer device and keep 3 ml of cell culture medium in the dish. Most LigandTracer assays are conducted at room temperature, but it is possible to use the device at reduced temperature (+4 to 8 °C) if deemed necessary.
2. Start the device and collect a baseline using the default settings during 3–10 min.
3. Stop the device and add a small aliquot of labelled antibody to the dish. Add 1 µg of antibody to the 3 ml liquid already present in the dish, this corresponds to approximately 2 nM. Start the device and wait 120–180 min.
4. Inspect the shape of the binding curve and compare it to Fig. 5.
 - (a) If the first incubation step resulted in a curve approaching equilibrium, stop the instrument and add 2 µg antibody to the dish.
 - (b) If the first incubation step resulted in a linear curve of increasing signal, stop the instrument and add 9 µg antibody to the dish.
 - (c) If no linear or curvilinear signal increase is seen, add 9 µg antibody to the dish.
5. Start the device and wait 120–180 min.
6. Inspect the shape of the binding curve and compare it to Fig. 5.
 - (a) If the first and/or the second incubation step resulted in a curve approaching equilibrium, stop the instrument and prepare for retention (**step 9** below).
 - (b) If the second incubation step resulted in a curve approaching equilibrium, stop the instrument and prepare for retention (**step 9** below).
 - (c) If the first and the second incubation steps resulted in a linear increase of signal, stop the instrument and add 20 µg antibody to the dish.
 - (d) If no linear or curvilinear signal increase is seen, add 20 µg antibody to the dish.
7. Start the device and wait 120–180 min.
8. Inspect the shape of the binding curve and compare it to Fig. 5.
 - (a) If there is a visible binding signal, prepare for retention (**step 9** below).
 - (b) If there is no visible binding signal, stop the measurement and conclude that no binding can be detected.

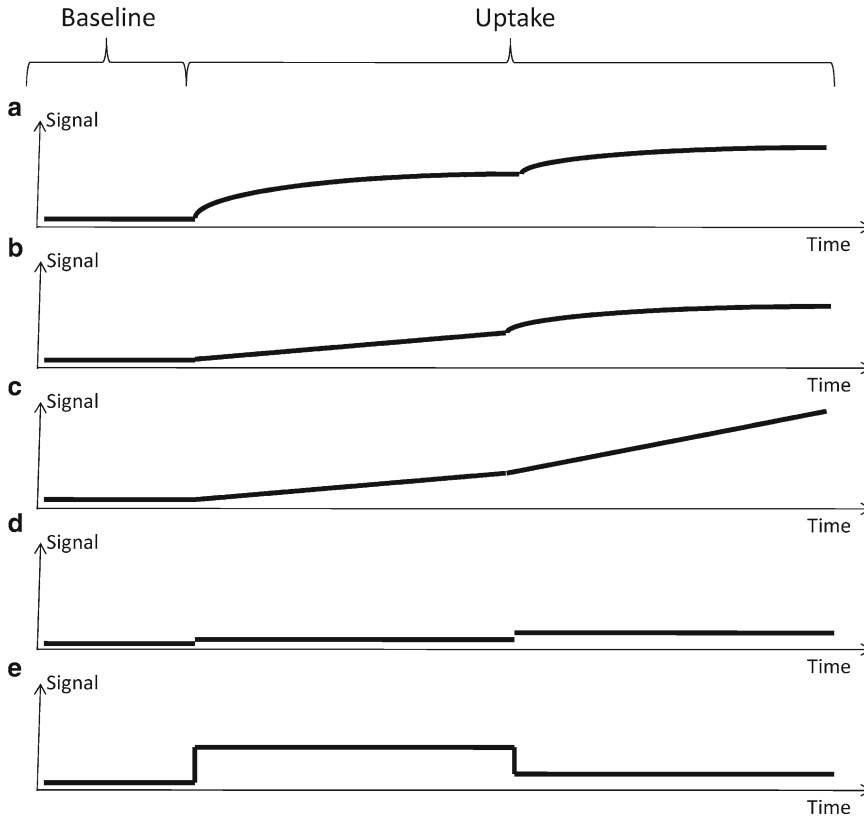

Fig. 5 Illustrative examples of two incubation steps of increasing antibody concentration in a LigandTracer assay. **(a)** Binding *curve* clearly approaching equilibrium at both concentrations is a strong proof for specific interaction. **(b)** First a linear signal increase, followed by the binding *curve* approaching equilibrium is a strong proof for specific interaction. **(c)** Linear signal increases at all tested concentrations can have multiple causes, including too low antibody concentration and unspecific interaction, and is hence inconclusive regarding binding properties. **(d)** No or very small signal changes throughout the assay is usually indicative of antibody inability to bind antigens, but may also be due to insufficient number of cells. **(e)** *Square* pulse like binding traces is usually indicative of antibody inability to bind antigens but can have multiple causes, including weak antibody interaction

9. Retention measurement: Stop the instrument and aspirate the liquid in the cell dish. Add 3 ml of fresh cell culture medium. It is typically not required to include any wash steps. Restart the instrument and let it collect data for 3–15 h.

3.7.3 Data Analysis

Ocular analysis of the binding trace is often sufficient for a qualitative statement on if the antibody has the ability to bind the antigen. The most important feature to look for is a binding signal collected during incubation that approaches equilibrium (Fig. 5a, b). Such a curve shape indicates that the antibody binds to a finite number of antigen molecules on the cells. Exclusively linear uptake curves (Fig. 5c) are inconclusive, but indicate that either higher concen-

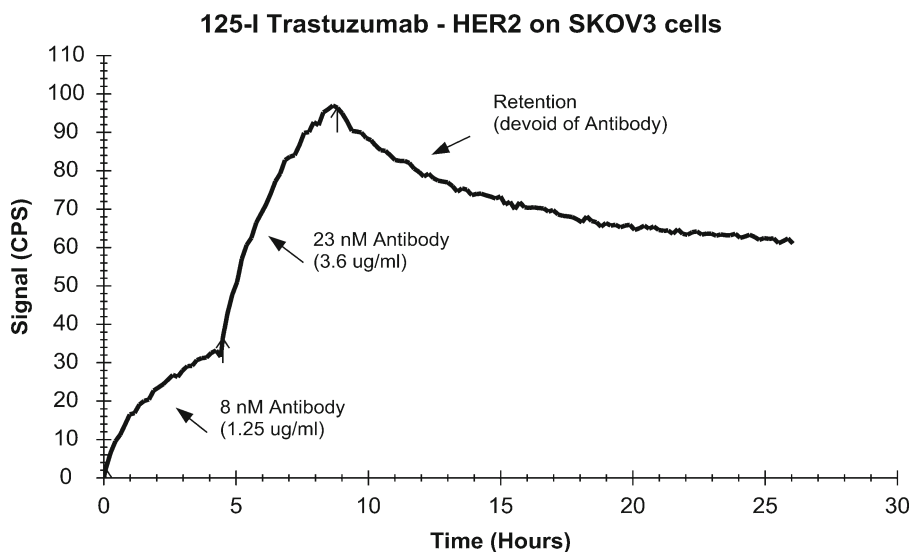

Fig. 6 Antibody trastuzumab (labelled with ^{125}I using the CAT protocol) interacting with HER2 expressed on SKOV3 cells, as measured using LigandTracer Grey

tration (or more time) is needed or that the interaction is unspecific (i.e., having an infinite or at least very large number of binding sites on the cells). Lack of signal (Fig. 5d), or square pulses (Fig. 5d), is usually a sign of inability for the antibody to bind.

The retention measurement which is conducted after replacing the antibody with fresh cell culture medium reveals how long time the antibody stays in complex with the antigen. Most antibodies stay bound with their antigen for several hours, resulting in a slowly decreasing signal (Fig. 6).

The affinity and the binding kinetics can be resolved through fitting the time-resolved interaction model to the collected data in specialized software, e.g., TraceDrawer. Such an analysis can produce precise and accurate estimates on both binding strength (affinity), and time to equilibrium (binding kinetics), and may even reveal how many parallel processes that are hidden in one and the same binding trace (Interaction Map). Detailed discussions on kinetic analysis are beyond the scope of this publication, but plenty of material has been published elsewhere [18, 19] *see* Note 10.

4 Notes

1. Radionuclides emit ionizing radiation, which is potentially damaging for workers. During work, the Radiation Safety guidelines set by institutions and the national nuclear regulatory authorities must be followed strictly and meticulously. Protective equipment, personal dosimeters, and radiation

survey monitors are required when handling any radioactive materials.

2. CHX-A''DTPA has no particular selectivity for radionuclides and reacts with a broad range of transitional metals. Metal contaminations may saturate the chelator and prevent binding of radionuclides. All solution should be prepared using high quality (Milli-Q or ELGA) water. Buffers should be purified from metal contamination using Chelex 100 resin. Colorless polypropylene Eppendorf tubes and pipette tips contain usually low level of metal impurities, and might be used directly. However, care should be taken to prevent them from dust contamination, as dust might contain metals. For some preparations with very high specific activity, reaction tubes and pipette tips might additionally treated as described by Wadas and Anderson [20].
3. Receptor expression on the selected cell line can be a limiting factor in case of low expression level or high K_D value due to receptor depletion. In the sample with highest cell concentration, antigens have to be in a large excess over antibody.
4. Time to equilibrium in the antibody/antigen interaction can be another limiting factor. In the case of slow binding kinetics, incubation time should be prolonged.
5. In the case when cell number is not a limiting factor and receptor expression is high, estimation of Immunoreactive fraction can be done using one data point with cell pellets of $1-2 \times 10^7$ cells/pellet. In such conditions $X \rightarrow 0$ [21]. The Immunoreactive fraction can be calculated as

$$\text{IRF} = \frac{A(\text{pellets} + \text{supernatant}) \times 100\%}{A(\text{pellets} + \text{supernatant}) + A(\text{supernatant})}$$

6. Radioactivity in solution with the lowest and the highest concentrations added to the cells have to be measurable using gamma-counter. If radioactivity in solutions for high concentrations will be too high (causing problems with the dead time of the counter) samples can be divided in several test tubes. Do not forget to collect pipette tips for radioactivity measurements.
7. The accuracy of the method depends on accurate estimation of the antibody concentrations used in the experiment. Take in account that in consecutive dilutions real protein concentrations can be lower than calculated ones due to absorbance to plastic. Therefore, it is strongly recommended to take a standard sample to every added concentration and recalculate the real concentrations based on radioactivity measurements.

8. Internalization of radiolabelled antibodies may influence appreciable the measurement result leading to overestimation of the bound radioactivity in the case of residualizing radio-metal labels (due to intracellular trapping of internalized antibody) and underestimation of bound activity in the case of radioiodine labels (due to leakage of radiocatabolites). *For this reason, the assay must be performed at 4 °C or on ice, when internalization is inhibited.*
9. Remember that the time to equilibrium depends on concentration, on-rate and off-rate of the antibody–antigen interaction. In the case of strongly binding antibody (and in particular low off-rate), time of equilibrium might be equal to several hours or even days. Too short incubation would cause a serious underestimate of the affinity. For this reason, it is desirable to evaluate a binding kinetics of an antibody *at lowest concentration* before determination of K_D and select incubation time when the plateau of uptake is achieved. The use of LigandTracer is free from this limitation.
10. If the cells detach during the LigandTracer measurement, inaccurate data will be collected. The detection limit of LigandTracer method depends on the cellular system, but is typically 30,000–50,000 receptors per cell.

References

1. van Dongen GA et al (2007) Immuno-PET: a navigator in monoclonal antibody development and applications. *Oncologist* 12:1379–1389
2. Geissler F et al (1992) Intracellular catabolism of radiolabeled anti-mu antibodies by malignant B-cells. *Cancer Res* 52:2907–2915
3. Kyriakos RJ et al (1992) The fate of antibodies bound to the surface of tumor cells in vitro. *Cancer Res* 52:835–842
4. Mattes MJ et al (1994) Processing of antibody–radioisotope conjugates after binding to the surface of tumor cells. *Cancer* 73:787–793
5. Shih LB et al (1994) The processing and fate of antibodies and their radiolabels bound to the surface of tumor cells in vitro: a comparison of nine radiolabels. *J Nucl Med* 35:899–908
6. Tolmachev V, Orlova A, Lundqvist H (2003) Approaches to improve cellular retention of radiohalogen labels delivered by internalising tumour-targeting proteins and peptides. *Curr Med Chem* 10:2447–2460
7. DeNardo GL et al (2004) Radiometals as payloads for radioimmunotherapy for lymphoma. *Clin Lymphoma* 5(Suppl 1):S5–S10
8. Malmberg J et al (2011) Comparative biodistribution of imaging agents for in vivo molecular profiling of disseminated prostate cancer in mice bearing prostate cancer xenografts: focus on ¹¹¹In- and ¹²⁵I-labeled anti-HER2 humanized monoclonal trastuzumab and ABY-025 affibody. *Nucl Med Biol* 38:1093–1102
9. Hunter WM, Greenwood FC (1962) Preparation of iodine-131 labelled human growth hormones of high specific activity. *Nature* 194:495–496
10. Wilbur DS (1992) Radiohalogenation of proteins: an overview of radionuclides, labeling methods, and reagents for conjugate labeling. *Bioconjug Chem* 3:433–470
11. Olafsen T et al (1996) Abundant tyrosine residues in the antigen binding site in anti-osteosarcoma monoclonal antibodies TP-1 and TP-3: application to radiolabeling. *Acta Oncol* 35:297–301
12. Nikula TK et al (1995) Impact of the high tyrosine fraction in complementarity determining regions: measured and predicted effects of radioiodination on IgG immunoreactivity. *Mol Immunol* 32:865–872
13. Olafsen T et al (1995) Cloning and sequencing of V genes from anti-osteosarcoma

- monoclonal antibodies TP-1 and TP-3: location of lysine residues and implications for radiolabeling. *Nucl Med Biol* 22:765–771
14. Lindmo T et al (1984) Determination of the immunoreactive fraction of radiolabeled monoclonal antibodies by linear extrapolation to binding at infinite antigen excess. *J Immunol Methods* 72:77–89
 15. Kozirowski J, Henssen C, Weinreich R (1998) A new convenient route to radioiodinated N-succinimidyl 3- and 4-iodobenzoate, two reagents for iodination of proteins. *Appl Radiat Isot* 49:955–959
 16. Björke H, Andersson K (2006) Automated, high-resolution cellular retention and uptake studies in vitro. *Appl Radiat Isot* 64:901–905
 17. Björkelund H et al (2011) Gefitinib induces epidermal growth factor receptor dimers which alters the interaction characteristics with ^{125I}-EGF. *PLoS One* 6:e24739
 18. Önell A, Andersson K (2005) Kinetic determinations of molecular interactions using Biacore—minimum data requirements for efficient experimental design. *J Mol Recognit* 18:307–317
 19. Björkelund H, Gedda L, Andersson K (2011) Avoiding false negative results in specificity analysis of protein–protein interactions. *J Mol Recognit* 24:81–89
 20. Wadas TJ, Anderson CJ (2006) Radiolabeling of TETA- and CB-TE2A-conjugated peptides with copper-64. *Nat Protoc* 1:3062–3068
 21. Wällberg H et al (2010) Evaluation of the radiocobalt-labeled [MMA-DOTA-Cys⁶¹]-Z_{HER2.2.395}-Cys antibody molecule for targeting of HER2-expressing tumors. *Mol Imaging Biol* 12:54–62

Purification of Human Monoclonal Antibodies and Their Fragments

Thomas Müller-Späth and Massimo Morbidelli

Abstract

This chapter summarizes the most common chromatographic mAb and mAb fragment purification methods, starting by elucidating the relevant properties of the compounds and introducing the various chromatography modes that are available and useful for this application. A focus is put on the capture step affinity and ion exchange chromatography. Aspects of scalability play an important role in judging the suitability of the methods. The chapter introduces also analytical chromatographic methods that can be utilized for quantification and purity control of the product. In the case of mAbs, for most purposes the purity obtained using an affinity capture step is sufficient. Polishing steps are required if material of particularly high purity needs to be generated. For mAb fragments, affinity chromatography is not yet fully established, and the capture step potentially may not provide material of high purity. Therefore, the available polishing techniques are touched upon briefly. In the case of mAb isoform and bispecific antibody purification, countercurrent chromatography techniques have been proven to be very useful and a part of this chapter has been dedicated to them, paying tribute to the rising interest in these antibody formats in research and industry.

Key words Purification, Downstream processing, Preparative chromatography, Affinity chromatography, Cation-exchange chromatography, Size-exclusion chromatography, Hydrophobic interaction chromatography, Protein A, Continuous chromatography, Countercurrent chromatography, Posttranslational modifications, MCSGP

1 Introduction

1.1 Properties of mAbs, mAb Isoforms, and mAb Fragments Relevant for Chromatographic Purification

As the production of monoclonal antibodies (mAbs) using recombinant cell technology has been developed and refined since the 1970s [1] so have been the technologies to purify them. Early antibody purification strategies comprised non-chromatographic steps such as flocculation and precipitation, which are in part rediscovered today [2]. Nevertheless, due to the availability of very robust and powerful chromatographic stationary phases providing excellent impurity clearance, manufacturing costs for mAbs have dropped to \$20–100/g [3]. By today, many biopharmaceutical

companies producing mAbs have developed fully industrialized generic platform downstream processes comprising 2–3 chromatographic steps [3–10] (*see Note 1*). As first step, almost exclusively affinity chromatography is used. In many cases, as second step (first polishing step), cation exchange chromatography is used in bind/elute mode. Anion exchange chromatography in flow through mode is frequently used as third chromatography step (second polishing step). Very roughly speaking, in the aforementioned three-step purification process, the purpose of the capture step is the removal of a large part of the host cell proteins, the main purpose of the cation exchange step is the removal of aggregates and the main purpose of anion exchange chromatography is the removal of host cell DNA and leaked protein A.

The gold standard in mAb affinity capture is protein A affinity chromatography which is based on the interaction of protein A, immobilized on the stationary phase, with the Fc region of the mAb molecule. The binding of protein A is not equally strong for all Immunoglobulins and, in the case of IgG, not equal for all subclasses. An indication about the expected binding strength can be found in [11]. A generally stronger binding is observed by protein G. In particular, protein G is able to bind to IgG₃, while protein A is not. Higher binding strength however does not automatically result in higher binding capacities. Also the presence of impurities may influence the binding capacity. Generally, in protein G chromatography, a stronger eluent is required to recover captured antibody from the affinity stationary phase. In both protein A and protein G affinity chromatography, the elution is carried out using a low pH buffer. In industrial applications, the affinity step eluate is typically held at low pH to inactivate viruses. However, low pH conditions may promote irreversible mAb aggregate formation. Since aggregation may also progress over time, it is important to identify pH conditions suitable for virus inactivation on the one hand but to maintain an acceptable aggregate content on the other hand. Thus, in most cases, protein A chromatography is preferred over protein G chromatography, since lower aggregate levels are generally obtained with the former one. The susceptibility of monoclonal antibodies to irreversible aggregation is dependent on their protein sequence, their conformation and the environmental conditions [12]. Irreversible aggregates comprise mainly mAb dimers, and readily during cell culture, irreversible aggregates are formed. For modern antibodies, typically 1–3 % mAb aggregates are observed in mAb cell culture supernatants. Except for low pH conditions during the elution from affinity media, generally the formation of new irreversible aggregates is not an issue in the chromatographic steps of the downstream processing of antibodies.

Monoclonal antibodies typically display charge heterogeneity due to posttranslational modifications [13–15]. Glycosylation is a major posttranslational modification influencing the activity of the monoclonal antibody [15]. However, different glycoforms of

full monoclonal antibodies cannot be resolved using standard chromatographic methods since the difference of the glycan sizes are typically small compared to the size of the mAb (1–3 %) and the glycans are not exposed on the outside of the molecule but directed towards the interior of the globular conformation (*N*-linked glycosylation). Even glycoforms of antibodies with *O*-linked glycosylation (with charged, sialylated glycans) in the Fab region have not been separated using standard chromatographic techniques to our knowledge. The most common glycans of mAbs do not carry charges at the conditions relevant for chromatography and therefore do not influence charge-based adsorption behavior.

MAB fragments are mostly produced using recombinant microbial expression systems such as *Escherichia coli* where glycosylation machineries have not yet been established in the industry. Thus, mAb fragments from these expression systems are generally not glycosylated. In contrast, other expression systems such as yeast are capable of glycosylation and yeast strains expressing human-like glycosylation patterns have been developed [16].

Charge heterogeneity of monoclonal antibodies and fragments can be induced by various mechanisms [14]. The most important ones are deamidation and lysine clipping. Deamidation introduces negative charges to the mAb molecule by converting an (exposed) amino group into a carboxyl group. Deamidation is promoted by storing the mAbs at elevated temperature (e.g., 25 °C) and pH (pH > 7). Lysine clipping is an enzymatic reaction taking place during the cell culture process. mAbs with C-terminal lysine groups (positive charge) may lose one or both lysine groups due to clipping. For further details on posttranslational modifications and the mechanisms for the induction of charge heterogeneity, the reader is referred to the literature [15]. The charge heterogeneity is an important feature of monoclonal antibodies that needs to be taken into account when purifying and analyzing mAbs by ion exchange chromatography. In ion exchange chromatography, broad eluting peaks due to charge heterogeneity must not be confused with broad peaks which are due to dispersion and mass transfer effects.

MABs and mAb fragments generally possess a high isoelectric point pI in the range of pH 8–9. To account for the abovementioned charge isoforms, often a pI range is reported in the literature, when a specific mAb is discussed. The high pI allows for purification by cation exchange chromatography since most impurities have a pI in the neutral or acidic range (the pI of DNA, for instance is at pH 2–3) and will pass through a cation exchange column at neutral pH or slightly acidic pH while the mAb is retained.

The key impurities in recombinant monoclonal antibody purification are host cell proteins (HCP). Host cell proteins represent a heterogeneous mixture of hundreds of proteins, some of them having “by accident” very similar adsorptive properties

(in non-affinity chromatography) as the mAb, leading to co-elution in non-affinity chromatography (e.g. CIEEX chromatography).

Due to their lack of Fc regions, HCPs are not captured by protein A while the selectivity of the protein A ligand for the mAb is extremely high, leading to excellent binding of the mAb.

However HCPs may adsorb non-specifically onto the stationary phase matrix. In addition, data has been presented indicating the association of HCP and mAb, leading to a co-purification of mAb and HCPs. Our observations confirm that this phenomenon is in fact widespread among mAbs. These recent findings highlight the importance of the washing steps in chromatography [17].

1.2 Chromatographic Purification of mAbs, mAb Isoforms and mAb Fragments

1.2.1 Affinity Chromatography

Today almost exclusively, protein A chromatography is used for antibody capture from cell culture supernatant. In order to prepare the harvest for protein A capture, the cells are removed (e.g., by centrifugation) and the supernatant is filtered. Afterwards, the clarified supernatant is loaded onto the equilibrated protein A column. After the loading, the column is typically washed with the equilibration buffer. Additional washes, such as a high salt wash or other washes with low concentrations of organic solvents or denaturants may be included in order to remove impurities that have adsorbed on the stationary phase or the mAb [17]. The elution of the captured mAb is typically done using a step gradient elution with a low pH buffer. The eluate is neutralized either right away or after a hold time (virus inactivation in industrial production). After the mAb elution the column is cleaned. Modern, polymer-based protein A affinity materials may be cleaned routinely with 0.1 M NaOH and may be sanitized using 0.5 M NaOH without a major loss of capacity allowing for running them over hundreds of cycles. After cleaning, the column is re-equilibrated for the next run or stored.

For mAb fragments the affinity-based chromatography has not been available until the last few years. The available affinity stationary phases have been developed only for a relatively short period compared to protein A stationary phases which have been developed for decades. Currently available κ/λ affinity stationary phase display much lower capacities and less chemical resistance compared to protein A/G stationary phases.

1.2.2 Size Exclusion Chromatography

Monoclonal antibodies are large molecules of typically about 150 kDa size which suggests separation from small molecular weight impurities by size exclusion chromatography (SEC). However, SEC processes generally have a low productivity since SEC is not adsorption-based and only a small amount of sample can be loaded. Typically, the feed volume is <4 % of the packed bed column volume. Due to its low productivities SEC is not attractive for large scale processing of mAbs or fragments. However it is useful for purification and characterization of proteins in product development where productivity and scalability are not of key

importance. In the form of small scale desalting cartridges (1–5 mL) it is a useful tool for rapid desalting and buffer exchange of mAb samples. SEC is also used as standard HPLC analytics to determine the aggregate content of mAb samples. Molecules of smaller molecular weight than the mAbs are typically less well resolved. Agarose and silica-based SEC columns are available for mAb analytics. SEC columns packed with silica-based, small, rigid particles and can be operated at higher flow rates and backpressures than columns packed with softer agarose based material. On the other hand, agarose based stationary phases can be cleaned with caustic soda while silica based materials are degraded when treated with caustic and should generally not be operated at pH 8.0 or above. Thus, if silica-based columns are used, it is recommended to use a guard column for protection, due to the limited cleaning possibilities.

1.2.3 *Hydrophobic Interaction Chromatography*

In contrast to other adsorption-based chromatography methods, hydrophobic interaction chromatography (HIC) is entropically driven and separating proteins according to their hydrophobicity. In mAb purification, the main purpose for using HIC is the removal of aggregates which are generally more hydrophobic than the monomeric proteins. Adsorption takes place at high salt concentrations, and typically low salt concentrations are used for desorption. The high salt concentrations, required for binding (typically 1–1.5 M ammonium sulfate), which raise the question of waste disposal, have made HIC unpopular for the purification of mAbs, particularly since powerful alternatives, such as multimodal chromatography, have become available.

1.2.4 *Multimodal Chromatography*

Multimodal chromatography (MMC) is increasingly used for the polishing of mAbs. It typically combines ion-exchange and HIC functionalities. The purpose of MMC is the removal of residual impurities like HCP, DNA and aggregates, preferably in flow-through mode. To obtain the best performance, both pH and ionic strength have to be optimized. Being based on polymeric backbones and synthetic ligands, the resins have high chemical resistance also towards cleaning with caustic soda.

1.2.5 *Ion Exchange Chromatography*

Due to their high pI mAbs are mostly purified in bind/elute mode in using cation exchange chromatography (CIEX) and in flow through mode (impurities bind) using anion exchange chromatography (AIEX). Both CIEX and AIEX stationary phases are available as weak and strong forms. The strong forms have very low and very high pK values, respectively, leaving them fully deprotonated (CIEX) or protonated (AIEX), respectively, at the pH values relevant for the purification of mAbs (ca. pH 4.0–8.5). Most common ligands of strong CIEX and AIEX materials are sulfonate (SO₃) and quaternary ammonia (Q) ligands. Weak CIEX and AIEX stationary phases have pK values close to or within the pH range

relevant for the purification of mAbs. This means that the resins have buffering capacities themselves which lead to (undesired) pH effects upon the change of the ionic strength [18]. With increasing awareness of this sensitivity and the demand for robust processes, the use of weak IEX stationary phases such as resins with COO (CIEX) or DEAE (AIEX) ligands in new process developments is declining.

In industrial mAb purification processes, CIEX is very commonly used as second purification step following protein A affinity capture. This combination makes use of the fact that the protein A eluate typically has a low pH, providing conditions that allow for binding of the mAb on the CIEX stationary phase. For mAb elution from CIEX typically salt gradients are used, either as linear or step gradients. The buffer systems are dependent on the pH range in which the CIEX step is operated. For instance, acetate buffers are used in a range of pH 4.5–5.5 while Phosphate buffers are suitable in a range of pH 6.5–7.5 [28]. The loads on CIEX are typically in the range of 10–100 mg mAb per milliliter of packed bed.

1.3 Operating Mode: Single- or Multicolumn?

1.3.1 Single Column Batch Chromatography

Single column (or “batch chromatography”) is the most commonly used operating mode for the purification of mAbs. In many cases the mAb can be isolated with high yield and purity using single column affinity chromatography due to the very different adsorptive properties of the mAb and most of the key impurities (HCPs). However, protein A affinity chromatography is much less effective when it comes to removal of mAb aggregates and mAb fragments that contain an Fc region. This is due to the fact that these impurities are product-related and display similar adsorptive properties as the product. Single column chromatography has full gradient capability and allows for the separation of complex mixtures into at least three fractions which is a prerequisite for successful purification of biomolecules using non-affinity chromatography. However, the mAb and the product-related impurities partially-overlap and cannot be separated with high yield and high purity simultaneously. This dilemma is called the “yield/purity trade-off” of (non-affinity) batch chromatography. The trade-off is observed frequently if product-related impurities are present. However, using countercurrent chromatography, even small differences in the adsorptive properties of the product and the impurities can be exploited allowing for achievement of high product yields and purities at the same time.

Further application examples of countercurrent chromatography include the “difficult” antibody separation cases of cation exchange purification of mAb isoforms [19, 20] and the isolation of bispecific antibodies from a mixture containing the parental antibodies [21].

1.3.2 *Countercurrent Chromatography for Capture and Polishing Applications*

Countercurrent chromatography exists in many embodiments; however, not all of them are equally suitable for mAb purification. In the literature often the term “continuous” is used as synonym for “countercurrent” chromatography. The countercurrent principle relates to the movement of stationary phase (chromatographic material) and mobile phase (buffer/solvent) in opposite directions. Since it is difficult to realize a process, where the (solid) stationary phase is physically moved in opposite direction to the mobile phase, in practice the movement is simulated by discretizing the chromatographic bed into multiple columns and actually moving inlet and outlet ports for buffers, feed solutions and products in a carousel fashion. Thus, countercurrent chromatography in practice features at least two columns. It has to be differentiated from parallelized single column chromatography which is subject to the yield-purity trade-off described earlier.

As mentioned above, large advantages in terms of yield and purity with respect to batch chromatography are to be expected in the case of “difficult” separations, where an overlap of the desired product with impurities is observed in a corresponding single column batch chromatogram.

Countercurrent chromatography processes suitable for solving the “difficult” separation cases have to be distinguished from countercurrent loading processes aiming solely at exploiting better the capacity of the stationary phase. The latter type of process features a capture mode using several interconnected columns and is known under the names BioSMB[®], BioSC[®], or CaptureSMB[®]. These countercurrent capture processes have in common that they allow for saturating the stationary phase beyond the dynamic binding capacity without product loss by using multiple (typically three) columns that are interconnected during the loading. Thus, the most upstream column can be completely saturated while the product that is breaking through is captured by the interconnected downstream column. Subsequently, the most upstream column can be washed, eluted and regenerated, while the second column becomes the first column to be loaded. Thus, depending on the discrepancy between the static and the dynamic capacity of the stationary phase, the resin utilization can be significantly improved. Thus, this technique can be particularly useful in the case where the stationary phase is expensive, e.g., affinity chromatography. However, the countercurrent capture processes described above do not resolve the yield/purity trade-off since the elution of the mAb is done in single column mode (elution column disconnected from the other columns).

A multicolumn technique that is much known for the separation of chiral compounds is the four-zone simulated moving bed chromatography (SMB) process with extract and raffinate removal. However, this technique is limited to two-fraction separations and cannot operate gradients, which disqualifies it for mAb purification.

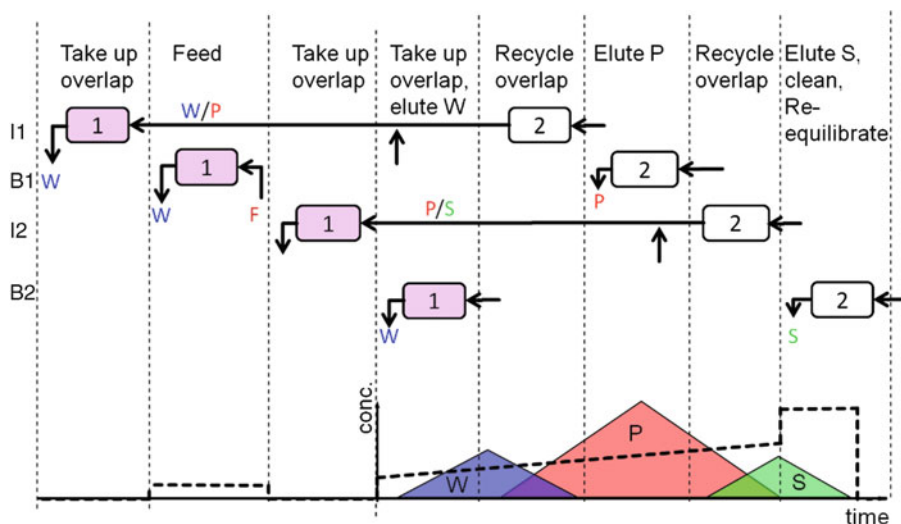

Fig. 1 Schematic illustration of the twin-column MCSGP process principle (first switch). The *dashed vertical lines* separate the different process tasks according to the zones of the schematic batch chromatogram shown in the lower part of the figure. Phases I1, B1, I2 and B2 are carried out sequentially

In contrast to SMB and the countercurrent capture processes, multicolumn countercurrent solvent gradient purification (MCSGP) solves the yield-purity trade-off of batch chromatography by internal recycling of the impure side fractions (parts in the chromatogram, where impurities and desired product are overlapping). MCSGP has linear gradient and three-fraction separation capabilities and uses columns with the same stationary phase as single column chromatography. MCSGP has proven to be very useful for removal of fragments and aggregates in mAb purification [22]. The determination of the MCSGP operating parameters (pump flow rates, gradient concentrations) can be carried out straight from a single column batch chromatogram without calculations. In the literature, so far 6, 5, 4 and 3-(identical) 2-column embodiments of MCSGP have been described [22–26]. Current applications and research confirm that the twin-column MCSGP process is about to replace the embodiments with three or more columns as it requires less hardware without compromising the performance.

A schematic of the twin-column MCSGP process for the separation of a ternary mixture using a linear gradient is provided in Fig. 1. MCSGP is based on the internal recycling of impure side fractions, which correspond to the overlapping fractions W/P and P/S as illustrated in Fig. 1. The columns are in interconnected mode for recycling of W/P and P/S and in single column batch mode for elution of the pure product P.

The chromatogram at the bottom of Fig. 1 shows a schematic batch chromatogram that has been divided into different sections

(vertical dashed lines) according to the tasks that were carried out in the batch chromatography run (equilibration, feeding, elution, cleaning). In addition, the elution phase is subdivided into different sections according to the presence of the components W (weakly adsorbing impurities), W/P (overlapping region), P (product), P/S (overlapping region), and S (strongly adsorbing impurities). Thus, there are sections where the components are present in a pure form (W, P, S) and there are the overlapping regions (W/P, P/S).

During each phase of the process the columns perform a specific task which corresponds to a section in the batch chromatogram. The tasks of the phases I1, B1, I2 and B2 (as indicated on the left of the figure) are carried out sequentially, by columns 1 and 2, respectively. Since there are eight tasks during each of the phases I1, B1, I2, B2, two tasks are carried out simultaneously.

A complete cycle of a twin-column MCSGP process comprises two “switches” with four phases each (I1, B1, I2, B2) as illustrated in Fig. 1. The phases in each switch are identical; the difference is only in the column position: In the first switch, column 1 is downstream of column 2 while in the second switch (not shown in Fig. 1) column 2 is downstream of column 1. The four phases correspond to the following tasks:

- Phase I1: The overlapping part W/P is internally recycled from the upstream into the downstream column. Thereby the recycling stream is diluted inline with buffer to allow for binding of P in the downstream column. At the end of phase A, pure product is ready for elution at the outlet of the upstream column.
- Phase B1: Pure P is eluted and collected from the upstream column, keeping the overlapping part P/S and S in the column. At the same time, fresh feed is injected into the downstream column.
- Phase I2: The overlapping part between P and S is internally recycled from the upstream into the downstream column. The recycling stream is diluted inline with buffer to allow for binding of P in the downstream column. At the end of the step, all P has been recycled and only S is left in the upstream column.
- Phase B2: The upstream column is cleaned to remove S and re-equilibrated. The columns switch positions. As in other countercurrent chromatographic processes, in MCSGP the columns are not physically moved but the movement is simulated by changing the flow paths through valve switching.

Due to the analogy between the process tasks of the single column batch process and the tasks of the MCSGP process, it is possible to derive the operating parameters for MCSGP from the batch operating parameters and the corresponding chromatogram. The operating parameter determination procedure is outlined in the method chapter.

2 Materials

2.1 Columns and Resins

Table 1 shows an overview of preparative and analytical chromatographic stationary phases suitable for the purification of monoclonal antibodies. In the analytical case the typical amount of antibody injected is in the order of magnitude of 10–100 µg/mL of packed bed volume while in preparative chromatography the load is typically in the range of 10–100 mg/mL of packed bed volume. Tables 1 and 2 show chromatographic materials that have been used successfully by the authors using the methods described later in this chapter. The analytical materials presented refer to pre-packed columns while for the preparative materials the names of the bulk materials are provided. However, also for the bulk materials, pre-packed columns of various sizes are available (refer to supplier). Most generally for production of small amounts of antibodies (mg–g range), 0.5–1.0 cm inner diameter columns with 10–15 cm length are sufficient.

2.2 Equipment

It is possible to carry out protein A chromatography using disposable or multi-use cartridges that can be supplied with buffers and feed using a syringe. This procedure is very simple but offers no control of important process parameters, such as the load and the flow velocity and a chromatogram may not be recorded. For reproducible results and proper process development, it is recommended to use an HPLC or a preparative device. Suppliers of HPLCs equipments are, for example, Agilent, Waters, Dionex. Preparative equipment is provided for example by GE Healthcare

Table 1
Columns for mAb and mAb fragment analysis

Chromatography type	Column name	Supplier	Particle diameter (µm)	Column size (i.D. × L) in (mm)
Protein A	Poros A20	Life technologies	20	2.1 × 3.0
CIEX (strong)	Tosoh SP STAT	Tosoh	7	4.6 × 100
CIEX (weak)	Propac wCX 10	Dionex	10	4 × 250
CIEX (strong)	Bio Pro SP-F 5	YMC	5	4.6 × 30
AIEX (strong)	Propax SAX 10	Dionex	10	4 × 250
AIEX (strong)	Bio Pro QA-F 5	YMC	5	4.6 × 30
SEC (<200 kDa)	Superdex 200 10/300 GL	GE Healthcare	34	10 × 300
SEC (<200 kDa)	TSKgel G3000 SWXL	Tosoh	5	7.8 × 300
SEC (<75 kDa)	Superdex 75 10/300 GL	GE Healthcare	34	10 × 300
HIC	Propac HIC 10	Dionex	5	4.6 × 100

Table 2
Stationary phases for preparative purification of mAb and mAb fragments

Chromatography type	Resin name	Supplier	Average particle diameter (μm)
Protein A	MAb Select SuRe	GE Healthcare	85
Protein A	Amsphere JWT203	JSR Life Sciences	50
Protein A	AF-rProtein A-650F	Tosoh	45
CIEX (strong)	Poros 50 HS	Life technologies	5
CIEX (strong)	Eshmuno S	Merck KgAA	85
CIEX (strong)	Toyopearl SP-650 M	Tosoh	65
AIEX (strong)	Poros 50 HQ	Life technologies	50
AIEX (strong)	Eshmuno Q	Merck KgAA	85
HIC	Toyopearl Phenyl-650 M	Tosoh	65

(ÄKTA series). A preparative system allowing also for the exploitation of the advantages of countercurrent chromatography is provided by ChromaCon (Contichrom series). All systems feature accurate pumps, a feed supply system (HPLC: autosampler, prep. Systems: sample pump), and a monitoring system (HPLC: UV, prep systems: UV, pH, cond).

A variety of technical solutions exist to speed up process development. A preliminary stationary phase and buffer screening can be carried out in 96-well plate format. Equipment for parallelization of single column batch chromatography is available too.

2.3 Protein A Affinity Chromatography

2.3.1 Buffers for Protein A Chromatography

The buffer recipes for the method are reported in Table 3. Buffer A is 25 mM Phosphate, 150 mM NaCl, pH 7.0, the wash buffer is 25 mM Phosphate, 1 M NaCl, pH 7.0, and the elution buffer is 100 mM Citrate, pH 3.0. Alternative elution buffers include 100 mM Glycine or 100 mM Acetate. The pH is adjusted using HCl or NaOH (1 M).

2.3.2 Feed Preparation for Protein A Chromatography

In order to prevent the chromatography column from being fouled it is important to remove cells, cell debris and other insoluble components from the starting material. A strongly recommended first step is centrifugation. A second required step is filtration (*see Note 2*).

2.3.3 Stationary Phases for Protein A Chromatography

The method was tested with MabSelect Sure (GE Healthcare), Amsphere JWT203 (JSR Life Sciences), and Tosoh AF-rProtein A-650F but it is expected to work for all preparative and analytical protein A stationary phases including cartridges. However, before using the method with other stationary phases, make sure that they are compatible with 0.1 M NaOH as cleaning agent and chose alternative cleaning agents if required.

Table 3
Buffers for protein A chromatography method

Substance (g)	Buffer A (equil)	Buffer B (wash)	Buffer C (elute)	CIP buffer (clean)
NaH ₂ PO ₄	0.8	0.8	0	0
Na ₂ HPO ₄	2.6	2.6	0	0
NaCl	8.8	58.4	0	0
Citric acid monohydrate	0	0	21.0	0
NaOH (solid)	0	0	0	4
Water (DI)	1,000	1,000	1,000	1,000
pH	Adjust to 7.0	Adjust to 7.0	Adjust to 3.0	Do not adjust

Table 4
Buffers for CIEX chromatography method

Substance (g)	Buffer A (equil)	Buffer B (wash)	CIP buffer (clean)
NaH ₂ PO ₄	0.8	0.8	0
Na ₂ HPO ₄	2.6	2.6	0
NaCl	0	58.4	0
NaOH (solid)	0	0	40
Water (DI)	1,000	1,000	1,000
pH	Adjust to 6.0	Adjust to 6.0	Do not adjust

2.4 Cation-Exchange chromatography

2.4.1 Buffers for CIEX

The buffer recipes for the method are reported in Table 4. Buffer A is 25 mM Phosphate, pH 6.0 and buffer B is 25 mM Phosphate, 1,000 mM NaCl, pH 6.0. The cleaning buffer is 1 M NaOH. The pH is adjusted using HCl or NaOH (1 M).

2.4.2 Feed

Preparation for CIEX

As a rule of thumb, in order to provide sufficient binding of the mAb on the CIEX stationary phase, the pH should be at least 1 unit below the pI of the mAb and the conductivity should be below 5 mS/cm. In order to reduce the ionic strength, the feed may be diluted with water, diafiltered against a suitable buffer or desalted using a desalting column (small scale only).

2.4.3 Stationary Phases for CIEX

The method described here was tested for multiple CIEX resins reported in Table 2. However, before using the method with other stationary phases, make sure that they are compatible with 1.0 M NaOH as cleaning agent.

3 Methods

3.1 Protein A Affinity Chromatography

The following protocol describes a generic protein A affinity chromatography capture method for mAbs of IgG subclasses 1, 2, 4. The method is intended to provide a starting point and has not been optimized. Always wear appropriate protective gear when preparing and performing experiments.

The protein A capture method is reported in the following. The step duration is given in column volumes (CV), which refers to the total packed bed column volume. As an example, 1 CV of a 0.5 i.D. \times 10 cm length column is 2 mL. The linear flow velocity u is defined as the ratio between the volumetric flow velocity Q and the column cross section A ($u = Q/A$). Thus, for the above-mentioned column, if Q is 1 mL/min, we obtain $u = 1 / 0.2 \text{ cm} / \text{min} = 5 \text{ cm} / \text{min} = 300 \text{ cm} / \text{h}$. The reported protein A capture method should be carried out at 300 cm/h. It comprises the following steps.

- Equilibrate 5 CV with 100 % buffer A (equilibrate).
- Load Feed (Feed).
- Wash 5 CV with 100 % buffer A (wash 1).
- Wash 5 CV with 100 % buffer B (wash 2).
- Wash 10 CV with 100 % buffer A (wash 3).
- Elute 5 CV with 100 % buffer C (step gradient elution, collect as fractions or pool).
- Rinse 2 CV with 100 % buffer A (rinse).
- CIP 8 CV with 100 % CIP buffer (clean).
- Re-equilibrate 8 CV with buffer A (re-equilibrate).

The feed volume is dependent on the antibody concentration and the capacity of the stationary phase is dependent on the feed composition (impurity content) and on the loading flow velocity. For modern cell culture supernatants with low impurity content, loads (dynamic capacities) of 30–40 mg mAb/mL of column volume can be obtained at a loading flow velocity of 300 cm/h.

Testing a loading capacity of $X \text{ mg/mL}$, the amount of column volumes of feed (CV_{feed}) that can be loaded are calculated by: $CV_{\text{feed}} = X / c_{\text{feed}}$. Thus, in the case of a loading capacity of 30 mg/mL and a feed concentration of $c_{\text{feed}} = 3 \text{ g/L}$, one would have to load $CV_{\text{feed}} = 10$ column volumes of feed.

After an optional hold at low pH (virus inactivation), the protein A eluate is neutralized in order to avoid formation of aggregates. For neutralization, a strong basic buffer should be used (e.g., 1 M Tris, pH 8.0).

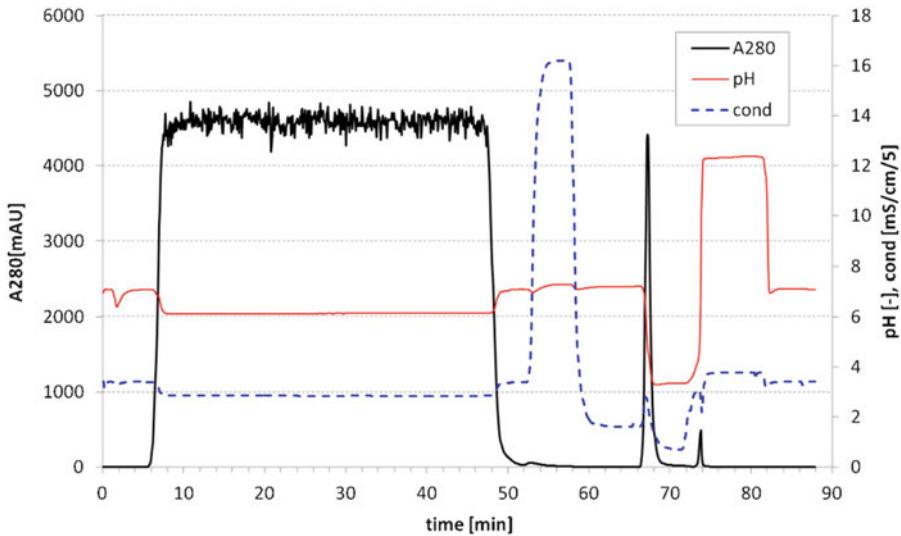

Fig. 2 Chromatogram obtained using the preparative protein A affinity chromatography method described in this chapter to capture mAb from clarified cell culture supernatant. The stationary phase was MabSelect SuRe packed into a 0.5 i.D. × 5 cm L column. The high UV signal during the loading step (5–45 min) is due to impurities in the flow through. The mAb is eluted at about 68 min as the pH drops. A small second peak is eluted as the column is cleaned using 0.1 M NaOH

A representative chromatogram from a direct capture of mAb from clarified cell culture supernatant is shown in Fig. 2.

The column is stored according to the manufacturer's instructions for the stationary phase. Most manufacturers recommend storage in 20 % Ethanol at 4–8 °C.

See **Note 3** for further information on protein A gradient selection and neutralization conditions and **Note 4** for antibody storage conditions.

3.2 CIEX Chromatography

The following protocol describes a bind/elute cation exchange method for purification of mAbs with a pI of 8 or higher. For antibodies with lower pI values 6.5–8, acetate buffers, pH 5.0 (same molarity) may be used. The method uses a linear gradient and may be used for both analytical and preparative purposes. Always wear appropriate protective gear when preparing and performing experiments.

The CIEX chromatography method is reported in the following. The step duration is given in column volumes (CV). Refer to protein A method description for calculation of the linear flow rate. The reported method should be carried out at 300 cm/h and comprises the following steps.

- Equilibrate 5 CV with 100 % buffer A (equilibrate).
- Load Feed (Feed).
- Wash 5 CV with 100 % buffer A (wash 1).
- Linear gradient from 100 % A to 100 % B in 10 CV (elution).
- CIP 8 CV with 100 % CIP buffer (clean).
- Re-equilibrate 5 CV with buffer B (re-equilibrate).
- Re-equilibrate 10 CV with buffer A (re-equilibrate).

As with protein A affinity chromatography, the feed volume is dependent on the antibody concentration and the capacity of the stationary phase is dependent on the feed composition (impurity content) and on the loading flow velocity. Furthermore it is dependent on the pH and the ionic strength of the feed (see section on ion exchange). When the mAb is captured from clarified cell culture supernatant in a preparative run, generally the ionic strength and the pH need to be adjusted. Cell culture harvest typically has a conductivity of 10–20 mS/cm and a pH value of 7.0–7.5. To achieve reasonable loads of 20–50 mg/mL (mg antibody per mL of packed bed) up to fourfold dilution (deionized water) and pH-adjustment to pH < 6.5 may be required. When adjusting the conditions, harvest components may precipitate requiring an additional filtration before loading onto the column. In the worst case, the mAb precipitates and other loading conditions need to be found. It is recommended to use 20 mg/mL as starting value for the preparative load in the case of preparative CIEX. If successful, the load may be generously increased in the following runs.

For mAb polishing using CIEX, in the case where the load conditions have been properly adjusted in terms of ionic strength and pH (e.g., protein A eluate), loads can exceed 100 mg/mL.

For analytical CIEX, the feed step in the method reported above is replaced by a single injection. Typical injection amounts are 10–100 μ g and no adjustment of the clarified and filtered sample prior to injection is required. An injection amount of 20 μ g mAb is recommended as starting value in the case of analytical CIEX.

In the cases where a high product concentration is more important than the product purity, a step gradient (0–100 % B) should be used instead of the linear gradient indicated above. This case has been reported for the purification of λ light chain fragment purification, where the high product concentration was important to increase the output of a subsequent SEC step (the feed volume is limited in SEC) [27].

Typically, the eluate from CIEX is stable for a couple of days-weeks at sterile conditions if stored at 4–8 °C (see **Note 4**). The column is stored according to the manufacturer's instructions for the stationary phase. Most manufacturers recommend storage in 20 % Ethanol at 4–8 °C.

3.3 SEC for mAb and mAb Fragment Purification

Despite its disadvantages in terms of throughput SEC can be a useful purification step on a small scale in cases where throughput and productivity are not of major importance. Since SEC is not adsorption-based and runs with standard buffers it requires only minimal process development. For mAb purification, it can be used for instance as a polishing step following protein A affinity chromatography

For the case of mAb fragment purification, affinity chromatography is not as well established and SEC can prove useful too. Arosio et al. [27] have reported the use of SEC for the purification of a λ light chain fragment, which was pre-concentrated using cation exchange chromatography (see above). They used a HiLoad™ 26/60 Superdex 75 prep grade column (GE Healthcare, Uppsala, SEC with a load of 12 mL CIEX eluate containing concentrated λ light chain fragment. The linear flow rate was 100 cm/h and 25 mM Phosphate, 100 mM Sulfate, adjusted to pH 7.0, was used as mobile phase.

In the case of large-scale mAb purification the combination of protein A/G affinity chromatography and CIEX has rendered SEC obsolete.

3.4 Analytics for mAbs and mAb Fragments

The following section very briefly describes the analytics that can be used to test the produced mAb and mAb fragment samples for aggregates, charged isoforms, HCP and DNA, respectively.

3.4.1 Analytical Size Exclusion Chromatography

The following analytical method was tested with Tosoh G3000 SWXL (with guard column) (7.8 × 300 mm) and for Superdex 200 10/300 GL on an Agilent 1100 HPLC series: The flow rate was 0.5 mL/min and the run time was for 65 min. the load was 20 μ g. The running buffer was 25 mM Phosphate, 100 mM Sulfate, adjusted to pH 7.0. Detection was done at 280 nm. Aggregates and high molecular weight impurities elute as pre-peak in front of the mAb monomer peak while low molecular weight impurities elute in the tail as shown in the result chromatogram in Fig. 3. When using SEC columns, make sure that the maximum acceptable pressure of the columns is not exceeded; reduce the flow rate if necessary. Try the method first with a load of 20–40 μ g.

3.4.2 Analytical Protein A Chromatography

Analytical protein A chromatography is useful for the quantification of mAb in product pools and other fractions. Essentially the same buffers as described in Table 3 can be used in combination with a simplified method:

- Injection.
- Wash 5 CV with 100 % buffer A (wash 1).
- Elute 10 CV with 100 % buffer C (step gradient).
- Re-equilibrate 15 CV with buffer A (re-equilibrate).

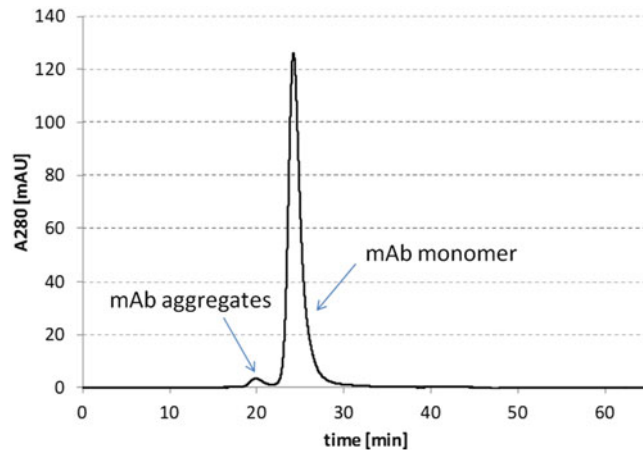

Fig. 3 Size exclusion chromatogram (Superdex 200 10/300 GL), of monoclonal antibody protein A eluate. mAb monomer and aggregates can be distinguished

The method does not include a cleaning step since less and purer sample is loaded onto the column compared to preparative protein A chromatography. However, regular column cleaning is recommended according to the manufacturer's instructions.

The detection is done at 280 nm. For rapid analytics, the linear flow rate should be maximized, however, remaining within the pressure limits of the column and the equipment. For instance, for the Poros A20 column (2.1 mm × 30 mm) a flow rate of 1 mL/min is well suited, which corresponds to a linear flow rate of 1,700 cm/h. Blank runs should be performed and subtracted from the sample runs. The detection limit is typically 0.05 mg/mL. Try the method first with a load of 10–20 µg.

3.4.3 Analytical CIEX Chromatography

Please refer to the description of the preparative CIEX method which is applicable also for analytical purposes. Try the method first with an injection of 20–40 µg as feed step.

3.4.4 HCP-ELISA, DNA Assay

HCP-ELISAs and DNA assays are carried out easily prefabricated, generic kits. Suppliers such as Cygnustechnologies (Southport, NC, USA) offer a large variety of HCP kits for various cell lines. For DNA quantification kits such as Quant-iT™ dsDNA assay kit (Invitrogen, Carlsbad, CA, USA) can be used. A 96-well plate reader is required for reading out the results.

3.5 Multicolumn Chromatography Design

In order to properly determine multicolumn chromatography (MCSGP) operating parameters, which are based on the section borders (Fig. 1) information of the product concentration and impurity concentration is required, as schematically illustrated in the batch chromatogram in Fig. 1. This information is typically obtained by fractionating a preparative single column linear gradient elution and analyzing the fractions by offline analysis.

In the following, the operating parameter determination procedure of a twin column MCSGP process is outlined briefly. In general, the operating parameters of the MCSGP process include two pump flow rates per phase (I1, B1, I2, B2), gradient concentrations (a linear gradient is defined by a start and end concentration) and finally switch times. No gradient is run during the feed step, the cleaning/re-equilibration step and by the inline dilution.

Once the section borders have been identified, the pump flow rates are calculated based on the elution volumes at the section border which are known from the single column batch flow rate and the section width. The gradient concentrations correspond to the gradient concentrations at the section borders.

The feed flow rate typically is set according to the amount of product that is expected to be eluted from the process during cyclic steady state (see “Elute P” section in Fig. 1). The inline dilution during the internal recycling steps is typically done using binding buffer and the cleaning and re-equilibration is typically also done isocratically.

The operating parameter determination procedure is outlined in [23] for a 6-column MCSGP process, an article describing more in detail the procedure for a 2-column process is in preparation. Sets of MCSGP operating parameters are provided in refs. 19, 20, supplementary material, and 22, supplementary material).

4 Notes

1. *Which purification for which purpose?* Obviously, depending on the purpose of the mAb material produced, different purity requirements persist. In industry, the purity specifications for HCP contents are typically < 10 ppm for the final product while cell culture supernatants frequently contain 100,000 ppm HCP or more. Figure 4 shows a schematic of a generic downstream process as applied in the industry with the roughly estimated impurity concentrations after each chromatography step. Protein A affinity chromatography generally reduces HCP content by 100–10,000 fold (2–4 logs). For purposes of antibody characterization (analytical chromatography, SDS page, IEF, MS) this level of purity is generally sufficient. Also if only milligram amounts of antibody are available (<100 mg), purification development cannot be carried out much beyond the capture step. A feasibility study of a downstream process using small scale columns (1–2 mL column volume) as shown in Fig. 4 requires at least 1 g of mAb. This does not include any scale up or process optimization.
2. *Supernatant filtration.* In order to prevent the chromatography column from being fouled it is important to remove cells, cell

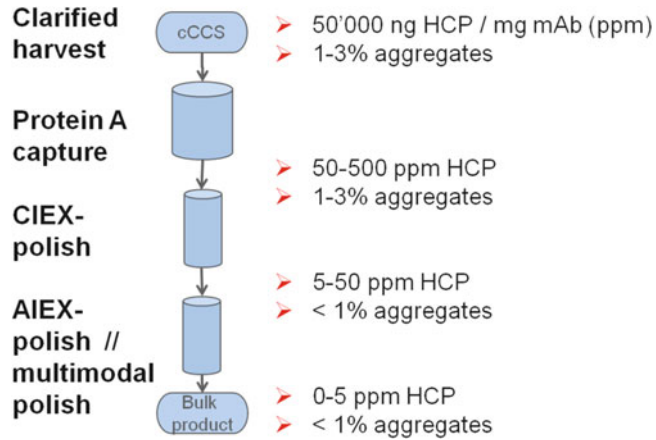

Fig. 4 Chromatographic steps of a generic industrial mAb downstream process. The roughly estimated impurity concentrations after each step are reported on the *right hand side* of the figure

debris and other insoluble components from the starting material. A recommended first step is centrifugation. A second required step is filtration. Depending on the amounts of starting solution to be filtered and the concentration of insoluble components, syringe filters (mL range), disk filters (mL–L range), depth filters (L range), or ultrafiltration (L range) may be used. The filter pore size should be 0.2–0.45 μm . For fast processing in the L range it is recommended to use a peristaltic pump.

3. *Protein A affinity chromatography.*

Experimental advice:

- Use a linear gradient instead of step gradient if excessive aggregation is observed (>5 % aggregates). The eluate will be less concentrated but the elution conditions are much gentler.
- In most cases for antibody preparation in research, virus inactivation is not relevant and the neutralization buffer may be readily added into the fraction collection containers. However, in the industry, virus clearance is of critical importance in the development of purification processes for drug candidates.
- It is recommended to neutralize the eluate in such way that it can be loaded onto the first polishing step without further treatment. For instance, if the first polishing step is a cation exchange step, it is recommended to neutralize the eluate to pH 5–6.
- Protein A eluate neutralization with 1 M or 0.1 M NaOH may lead to irreversible aggregate formation due very high

pH values that occur locally at the point of addition of the base in the eluate vessel. For 1 M Tris, pH 8.0 required neutralization buffer volume is typically in the range of 100–200 μL buffer per mL of protein A eluate.

4. *Storage of mAb solutions.* Most antibody solutions are stable for a couple of weeks when kept in the fridge 4–8 °C in buffers at pH 6.0 with 0.25 mg/mL sodium azide as preservative. Most antibodies are also freeze-thaw stable but freeze-thawing should not be exaggerated (<3 times) in order to minimize the formation of irreversible aggregates.

References

1. Köhler G, Milstein C (1975) Continuous cultures of fused cells secreting antibody of predefined specificity. *Nature* 256(5517):495–497
2. Liu HF, Ma J, Winter C, Bayer R (2010) Recovery and purification process development for monoclonal antibody production. *MAbs* 2(5):480–499
3. Kelley B (2009) Industrialization of mAb production technology. The bioprocessing industry at a crossroads. *MAbs* 1(5):443–452
4. Birch JR, Racher AJ (2006) Antibody production. *Adv Drug Deliv Rev* 58(5–6):671–685
5. Kelley B (2007) Very large scale monoclonal antibody purification: the case for conventional unit operations. *Biotechnol Prog* 23(5):995–1008
6. Low D, O’Leary R, Pujar NS (2007) Future of antibody purification. *J Chromatogr B Analyt Technol Biomed Life Sci* 848(1):48–63
7. Mehta A, Tse ML, Fogle J, Len A, Shrestha R, Fontes N, Lebreton B, Wolk B, van Reis R (2008) Purifying therapeutic monoclonal antibodies. *Chem Eng Progr* 104(5):S14–S20
8. Shukla AA, Hubbard B, Tressel T, Guhan S, Low D (2007) Downstream processing of monoclonal antibodies—application of platform approaches. *J Chromatogr B Analyt Technol Biomed Life Sci* 848(1):28–39
9. Walsh G (2005) Biopharmaceuticals: recent approvals and likely directions. *Trends Biotechnol* 23(11):553–558
10. Shukla AA, Thömmes J (2010) Recent advances in large-scale production of monoclonal antibodies and related proteins. *Trends Biotechnol* 28(5):253–261
11. (2007) Antibody purification handbook. GE Healthcare. Table 3.2 http://wolfson.huji.ac.il/purification/pdf/affinity/amersham_antibpurifhandbook.pdf
12. Arosio P, Barolo G, Müller-Späth T, Wu H, Morbidelli M (2011) Aggregation stability of a monoclonal antibody during downstream processing. *Pharm Res* 28(8):1884–1894
13. Harris RJ, Kabakoff B, Macchi FD, Shen FJ, Kwong M, Andya JD, Shire SJ, Bjork N, Totpal K, Chen AB (2001) Identification of multiple sources of charge heterogeneity in a recombinant antibody. *J Chromatogr B* 752(2):233–245
14. Walsh G, Jefferis R (2006) Post-translational modifications in the context of therapeutic proteins. *Nat Biotechnol* 24(10):1241–1252
15. Jefferis R (2009) Glycosylation as a strategy to improve antibody-based therapeutics. *Nat Rev Drug Discov* 8(3):226–234
16. Choi B-K, Bobrowicz P, Davidson RC, Hamilton SR, Kung DH, Li H, Miele RG, Nett JH, Wildt S, Gerngross TU (2003) Use of combinatorial genetic libraries to humanize N-linked glycosylation in the yeast *Pichia pastoris*. *Proc Natl Acad Sci* 100(9):5022–5027
17. Shukla AA, Hinckley P (2008) Host cell protein clearance during protein a chromatography: development of an improved column wash step. *Biotechnol Progr* 5(25):1115–1121
18. Pabst TM, Carta G (2007) pH transitions in cation exchange chromatographic columns containing weak acid groups. *J Chromatogr A* 1142(1):19–31
19. Muller-Spätth T, Aumann L, Melter L, Strohle G, Morbidelli M (2008) Chromatographic separation of three monoclonal antibody variants using multicolumn countercurrent solvent gradient purification (MCSGP). *Biotechnol Bioeng* 100(6):1166–1177
20. Muller-Spätth T, Krattli M, Aumann L, Strohle G, Morbidelli M (2010) Increasing the activity of monoclonal antibody therapeutics by continuous chromatography (MCSGP). *Biotechnol Bioeng* 107(4):652–662

21. Muller-Spath T, Ulmer N, Aumann L, Strohlein G, Bavand M, Hendriks LJA, de Kruif J, Throsby M, Bakker ABH (2013) Purifying common light-chain bispecific antibodies. *BioProcess International* 11(5):36–45
22. Muller-Spath T, Aumann L, Ströhlein G, Kornmann H, Valax P, Delegrange L, Charbaut E, Baer G, Lamproye A, Johnck M, Schulte M, Morbidelli M (2010) Two step capture and purification of IgG2 using multicolumn countercurrent solvent gradient purification (MCSGP). *Biotechnol Bioeng* 107(6):974–984
23. Aumann L, Morbidelli M (2007) A continuous multicolumn countercurrent solvent gradient purification (MCSGP) process. *Biotechnol Bioeng* 98(5):1043–1055
24. Strohlein G, Aumann L, Mazzotti M, Morbidelli M (2006) A continuous, countercurrent multi-column chromatographic process incorporating modifier gradients for ternary separations. *J Chromatogr A* 1126(1–2): 338–346
25. Aumann L, Morbidelli M (2008) A semicontinuous 3-column countercurrent solvent gradient purification (MCSGP) process. *Biotechnol Bioeng* 99(3):728–733
26. Aumann L, Morbidelli M. WO/2006/116886
27. Arosio P, Owczarz M, Müller-Spätth T, Rognoni P, Beeg M et al (2012) In vitro aggregation behavior of a non-amyloidogenic λ light chain dimer deriving from U266 multiple myeloma cells. *PLoS One* 7(3):e33372. doi:[10.1371/journal.pone.0033372](https://doi.org/10.1371/journal.pone.0033372)
28. (2010) Ion exchange chromatography & chromatofocusing – principles and methods handbook. GE Healthcare. Appendix 2, pp 160–161, http://www.gelifesciences.com/gehcls_images/GELS/Related%20Content/Files/1314823637792/litdoc11000421AB_20110901010317.pdf

Idiotype-Specific Intravenous Immunoglobulin (IVIg) for Therapy of Autoimmune Diseases

Miri Blank, Tomer Bashi, and Yehuda Shoenfeld

Abstract

Intravenous immunoglobulin (IVIg) is used successfully for therapy of inflammatory and autoimmune diseases, especially in cases of conventional therapy resistance. Within the broad spectrum of immunomodulatory activities of IVIg in vitro and in vivo, the anti-idiotypic activity, neutralizing the autoimmune disease related idiotypes, is one of the main mechanism. We and others have proven that from the IVIg composition, diverse fractions of autoimmune disease specific IVIg can be affinity purified (sIVIg). This sIVIg was shown to be more efficient than the whole compound of IVIg in experimental animal models of autoimmune diseases.

The affinity purification of disease sIVIg encompasses three stages. The first stage is to construct an autoantigen column for affinity purification of the autoantibodies. In the second stage the purified autoantibodies are used to construct a new column composed of the autoantibodies. The later is utilized for affinity purification of anti-autoantibodies (anti- idiotypes) IVIg defined as autoimmune disease specific IVIg- sIVIg.

Key words IVIg, Specific IVIg, Anti-idiotypic, Autoimmune disease, Immunomodulation

1 Introduction

Antibody-based therapy, which is the administration of polyclonal or monoclonal antibodies, has emerged as an important therapeutic approach in a wide variety of diseases including autoimmune. Polyclonal intravenous immunoglobulin (IVIg) became available in the early 1980s and supplanted intramuscular immunoglobulin G (IgG) in the treatment of antibody-deficiency diseases. During the last two decades, IVIg has shown potent immunomodulatory and anti-inflammatory effects in many diseases, from immune deficiency, autoimmune, infections, cancer supporting-therapy to other immune disorders [1–6]. IVIg contains more than 95 % intact IgG molecules, with traces of immunoglobulin A (IgA) (less than 2.5 %) and immunoglobulin M (IgM) (negligible). The therapeutic

immunomodulatory effect of IVIG lies within its content. A standard IVIG preparation contains natural polyreactive antibodies mainly anti-idiotypic which are able to neutralize and immunomodulate autoantibodies [3–6]. IVIG, when administered properly to a selected patient population, was shown to be an effective treatment in autoimmune and cancer diseases, as well as for recurrent pregnancy loss, with side effects that are mostly mild and transient [5, 7]. The notion that IVIG contains anti-idiotypic antibodies comes from Sultan's observation that 95 % of anti-factor VIII antibodies were cleared from patient's serum within 36 hours of IVIG treatment [8]. According with this, most of the clinical reports in SLE patients demonstrate significant decline of anti-double stranded-DNA (anti-dsDNA) autoantibodies after the treatment with IVIG [9]. Evidently, commercial IVIG preparations contain anti-idiotypic antibodies against anti-factor VIII antibodies [8] and anti-DNA autoantibodies [10, 11], as well as other autoantibodies such as anti-intrinsic factor antibodies [11], anti-thyroglobulin autoantibodies [11], anti-neutrophil cytoplasmic antibodies [12], anti-microsomal antibodies [13], anti-neuroblastoma antibodies [14], anti-phospholipid antibodies [15], anti-platelet antibodies [16], anti-Sm idiotype (4B4) [17], and anti-GM1 antibodies [18]. These anti-idiotypic antibodies can inhibit the binding of the pathogenic autoantibodies to their corresponding antigen *in vitro* [10, 11] and *in vivo*, thereby treating or preventing disease manifestations [15, 17, 19]. Another possible explanation for the beneficial effect of IVIG anti-idiotypic antibodies is their inhibitory effect on the spontaneous secretion of anti-dsDNA by peripheral B lymphocytes, as was demonstrated *in vitro* [20]. We and others believe that the idiotypic network is an important mechanism for controlling the immune repertoire.

Although the commercial IVIG compound encompass a wide rainbow of anti-idiotypic antibodies, it is given "as-is" to diverse autoimmune diseases. Therefore, there is a need to fractionate disease specific IVIG which may be may have high disease specificity in a lower concentration.

During the last decade we have generated specific IVIG to disease specific idiotypes which were proven to be significantly more effective than the commercial IVIG compound [21–25]. We fractionated from IVIG a specific anti-anti-dsDNA anti-idiotypic antibodies for SLE (lupus-sIVIG), which was proven to be 200 times more effective in ameliorating lupus nephritis in NZBxW/F1 lupus prone mice than the whole IVIG [21]. Specific anti-anti- β_2 glycoprotein-I anti-idiotypic antibodies were affinity purified for antiphospholipid syndrome (APS-sIVIG) were 200 times more efficient than the original IVIG in preventing fetal loss in APS mice and 500 times more efficient in supporting *in vitro* human trophoblast invasiveness [22]. Specific anti-anti-desmoglein-1,3 anti-idiotypic IVIG for pemphigus vulgaris (PV-sIVIG) prevented the

development of acantholysis in experimental PV mice 66 folds more than the whole IVIG compound at the same concentration [23]. Anti-anti-myeloperoxidase anti-idiotypic antibodies (MPO-ANCA-sIVIG) were fractionated for small vessel vasculitis (Churg-Strauss syndrome and microscopic polyangiitis) and significantly inhibited TNF α -primed neutrophils' oxidative burst, in comparison to the whole IVIG [24]. Autoimmune sIVIG has the advantage of being more specific, more effective and can be used in much lower concentration than the whole IVIG compound.

2 Materials

Prepare all buffers using ultrapure water and filter them with 0.45 μ m filter before use. Store the sera which will serve as the origin for autoantibodies affinity purification, in 2 ml aliquots at -20°C . Save the reagents at room temperature, freeze the purified immunoglobulins in aliquots at -20°C until use.

2.1 Purification of Anti-dsDNA Autoantibodies

- DNA-cellulose (Pharmacia Biotech Inc., USA).
- Pierce BCA protein assay (Thermo Scientific, Rockford, IL, USA).
- Tris buffer (TBS) 0.025 M Tris, 0.145 M NaCl, pH 7.4.
- Elution solution 2.5 M MgCl₂ (*see Note 1*).
- Pierce BCA protein assay (Thermo Scientific, Rockford, IL, USA).
- Anti-dsDNA ELISA kit: ORGenTec Diagnostika GmbH, Mainz, Germany.

2.2 Purification of Anti-Protein/ Glycoprotein Autoantibodies

1. HiTrap™ *N*-hydroxysuccinimide (NHS)-activated-Sepharose™ High Performance (GE Healthcare Bioscience AB Uppsala, Sweden) (*see Note 2*).
 - Coupling buffer: 0.2 M NaHCO₃, 0.5 M NaCl, pH-8.3.
 - Buffer A: 0.5 M ethanolamine, 0.5 M NaCl, pH-8.3.
 - Buffer B: 0.1 M acetate, 0.5 M NaCl, pH-4.
 - Equilibration buffer: 0.1 M NaH₂PO₄, 0.15 M NaCl, pH-7.0.
 - Storage solution: 0.05 M Na₂HPO₄, 0.1 % NaN₃, pH-7.0.
 - Elution buffer, 0.2 M glycine-HCl, pH 2.5
 - Neutralizing Tris buffer, 2 M Tris pH 8 (*see Note 3*).
2. Cyanogen bromide (CNBr)-activated Sepharose 4B Fast Flow.
 - Glass filter with 0.45 μ m nitrocellulose membrane.
 - Coupling buffer: 0.1 M NaHCO₃, 0.5 M NaCl, pH 8.

- Glycine blocking buffer, 0.2 M, pH 8.0.
- PBST: NaCl 137 mM, KCl 2.7 mM, Na₂HPO₄·7H₂O 4.3 mM, KH₂PO₄ 1.4 mM, Tween20 0.05 %.
- Low pH wash: 0.1 M acetic acid, 0.5 M NaCl, pH 4.0.
- Elution buffer: 0.1 M Glycine–HCl pH 2.5.
- Neutralization buffer: 2 M Tris pH 8.

2.3 Biotinylation

- Biotinylation solution: Biotinamidocaproate-*N*-Hydroxy-Succinimide-Ester in 10 µg in 1 ml Dimethylformamide (*see* **Note 4**).

3 Methods

The principle of preparation of disease specific anti-idiotypic IVIG, is by affinity purification of antibodies which has disease specific idiotypic activity (*see* **Note 5**), generating a column which is composed of the idiotypes, loading IVIG and elution of anti-idiotypic IVIG, a disease specific sIVIG.

3.1 Affinity Purification of Disease Specific Autoantibodies

In order to affinity purify autoantibodies, construct a column that will present the specific autoantigen. Next, load patients' sera and elute the specific autoantibodies.

Example 1: Purification of Anti-dsDNA Autoantibodies

1. Use DNA-cellulose pre-equilibrated with Tris buffer. Load serum from relevant patient with an autoimmune disease at an *active* stage of disease. Load 2 ml of patient serum diluted five times with TBS for 4 h at room temperature.
2. Wash the column with Tris buffer to remove the unbound material until the optical density (OD) will reach about 0.05 OD at 280 nm.
3. Elute the bound immunoglobulins with elution solution, collect 1 ml fractions and check the density values of absorbance at 280 nm.
4. Wash the column from unbound material until the OD is stable on about 0.05 OD at 280 nm.
5. Collect protein containing fractions according to OD values and extensively dialyze against Tris buffer.
6. Store the column at 4 °C. If you store for more than a week, add 5 ml Tris buffer+0.02 % NaN₃ to avoid contamination.
7. Define the protein concentrations of the fractions by employing "BCA protein assay" according to the manufacturer protocol.

8. Test the efficacy of the column by following the anti-dsDNA activity. Add the eluated/dialyzed fractions and the flow-through of the affinity column at different dilution using anti-dsDNA ELISA Kit.

Example 2: Purification of Anti-Protein/Glycoprotein/Peptide Autoantibodies

Stage 1: Ligand Coupling to HiTrap™ NHS-Activated HP Column

1. Dissolve ligand in coupling buffer to 0.5–10 mg in 10 ml coupling buffer if you use a pump (*see Note 6*).
2. Wash out the isopropanol with 1 mM HCl, ice-cold. Use 3 × 2 ml for HiTrap 1 ml and 3 × 10 ml for HiTrap 5 ml. Be sure not to exceed flow rates of 1 ml/min (1/2 drop/s) for HiTrap 1 ml and 5 ml/min (2 drop/s) for HiTrap 5 ml at this stage. Do not exceed flow rate of 1 ml/min.
3. Immediately inject 1 ml of the ligand solution in coupling buffer into the HiTrap™ column.
4. Seal the column and let it stand for 4 h at 4 °C.
5. Washing and deactivation (*see Note 7*).
 - (a) Inject three times 2 ml of buffer A
 - (b) Inject three times 2 ml of buffer BRepeat **steps a** and **b** procedures three times
6. Store the column at 4 °C. If you store for more than a week, add 5 ml Tris buffer + 0.02 % NaN₃ to avoid contamination.

Stage 2: Fractionation of the Autoantibodies

1. Load 2 ml serum from a patient with an autoimmune disease after filter though 0.45 mm, on a specific ligand column, at an active stage of the disease, with high titer of disease specific autoantibodies which are directed to the ligand bound to the column, 4 h at room temperature or overnight at 4 °C.
2. Wash extensively the column with Tris buffer.
3. Elute the fractions of the bound immunoglobulin with 0.2 M glycine-HCl, pH 2.5, collect fraction of ~500 ml in microfuge tubes and immediately neutralized with 2 M Tris pH 8 (*see Note 3*).
4. Dialyze the eluted fractions against Tris buffer.
5. Define the protein concentration using the BCA kit.
6. Test the specificity of the affinity purified autoantibodies binding to the autoantigen using specific ELISA or Western immunoblot.

3.2 Construction of an Autoantibodies Column

1. Swell freeze-dried CNBr-activated Sepharose 4B (1 g) resin by incubation with 100 ml of 1 mM HCl 60 min at room temperature with rotator (*see Note 8*).
2. Wash the resin with 200 ml 1 mM HCl on a glass filter 0.45 μm using vacuum.
3. Wash the resin again with 200 ml coupling buffer using vacuum.
4. Remove coupling buffer by spinning at 4,000 rpm ($350\times g$), 1 min at room temperature.
5. 2 mg/5 ml of affinity purified autoantibodies, with or without combination with monoclonal antibodies or alternatively scFVs, dialyze against coupling buffer overnight at 4 °C. Add the immunoglobulins to the pelleted resin and incubate with rotation 6 h at room temperature or overnight at 4 °C. The autoantibodies will be covalently bound to the CNBr-activated Sepharose 4B swelled resin in coupling buffer.
6. Add 25 ml blocking buffer for 2 h at room temperature or overnight at 4 °C, in order to block the remaining active NH groups. Transfer to a BioRad column and allow resin to settle.
7. To remove excess of non-bound autoantibodies and glycine, repeat three cycles of washing with 20 ml followed by 20 ml of PBST buffer followed (*see Note 9*).
8. The washed column should be equilibrated with sterile Tris-HCl buffer pH 7.4.

3.3 Affinity Purification of Disease Specific IVG (sIVIG)

1. Dialyze 500 mg (10 ml) of the commercial IVIG preparation (5 % Ig). Against loading buffer (0.05 M Tris containing 0.5 M NaCl, pH 8.0), diluted in 50 ml of loading buffer, filtered through the 0.45 μm filter (Minisart, Sartorius AG, Germany).
2. Load the IVIG for 16 h at 4 °C on the column composed of the disease specific autoantibodies.
3. Wash out the unbound material with Tris buffer.
4. Elute the bound IVIG with 0.2 M glycine-HCl, pH 2.5 and immediately neutralized with 2 M Tris.
5. Dialyze the relevant fractions against Tris buffered, sterilized by membrane filtration on a low protein binding acetate filter (0.2 μm) and frozen in aliquots at -70 °C.

3.4 Assay for the In Vitro Efficacy of the Disease Specific sIVIG Activity

To prove the anti-idiotypic activity of sIVIG in comparison to IVIG, inhibition studies should be performed by ELISA.

1. Due to the fact that all the immunoglobulins are from a human origin, there is a need to biotinylate the autoantibodies in order to follow the potential of IVIG or sIVIG to inhibit the autoantibody binding to the autoantigen.

Biotinylation procedure: Dialyze autoantibodies and control IgG at concentration of 100 µg/100 µl against 0.1 M NaHCO₃ for 4 h at room temperature or overnight at 4 °C. Apply 10 µl biotinylation buffer to 100 µl antibodies for 2 h at room temperature with mild shaking and dialyze against Tris buffer. Test the efficacy of the biotinylation on an anti-human-IgG coated ELISA plates (1 µg/ml 0.1 M NaHCO₃ pH 8.6 overnight at 4 °C followed by blocking with 3 % BSA in Tris buffer for 1 h at 37 °C). Probe the binding with streptavidin-alkaline phosphatase (at dilution recommended by the company), followed by appropriate substrate. Perform extensive washings with Tris buffer between the steps. Read the ELISA plate at OD of 405 nm by ELISA reader.

2. Define the 50 % binding of disease specific autoantibodies to the autoantigen by ELISA. Commercial kit or homemade plates may be used. Apply to the autoantigen coated, blocked plates, affinity purified autoantibodies from patients with an autoimmune disease or commercial IgG as a control immunoglobulin at different dilutions, incubate for 2 h at room temperature with moderate shaking. Probe the binding by anti-human IgG alkaline phosphatase (at concentration recommended by the company) followed by appropriate substrate, supplied by the relevant kit. Read the plate at 405 nm OD.
3. Combine the affinity purified biotinylated autoantibodies at 50 % binding to the specific autoantigen, with different concentration of IVIG or sIVIG. Incubate overnight at 4 °C. Apply the mixture to ELISA plates coated with the autoantigen as used for defining the 50 % binding. Probe the autoantibodies binding to the autoantigen by streptavidin conjugated with alkaline phosphatase followed by appropriate substrate. Read the plate at 405 nm optical density. Calculate the percent of inhibition as follow:

$$\% \text{ inhibition} = 100 - [(\text{OD of 0 inhibitor} - \text{OD with inhibitor}) / \text{OD without inhibitor}] \times 100].$$

4 Notes

1. If the MgCl₂ stock solution is too sticky, warm the solution to room temperature or 30 min at 37 °C, before using for elution.
2. This prepacked column is ready to use. It is a disposable column for preparative affinity purification. The column can be operated with a syringe or peristaltic pump. Keep the column at 4 °C. Before use, remove the top-cap and apply a drop of *ice cold* 1 mM HCl to the top of the column to avoid air bubbles.

Connect the HiTrap luer adaptor (or tubing from a system) to the top of the column. Remove the twist-off end.

3. Before the elution step, calibrate the amount of 2 M Tris pH 8 to be added to the elution solution in order to get pH 7.4.
4. The biotinylation solution in dimethylformamide can be stored a week at 4 °C.
5. Affinity purify autoantibodies from each patient separately and keep in 2 ml aliquots at -70 °C. Use for each autoimmune disease between 15 and 40 sera from different patients at an *active stage of disease*, with high titer of ligand specific autoantibodies. Combine the eluted affinity purified immunoglobulins *only* when you construct the idiotype column, to avoid cross reaction between the immunoglobulins.
6. If the ligand is in another solution, dialyze it in coupling buffer to exchange the buffer, to be ready for coupling to the column.
7. Buffer A is used for deactivation of excess of unbound active groups. Buffer B is used for washing out of non specific bound ligands. After the procedure of deactivation and washings, if you are not going to use this column within a week add 2 ml of storage buffer.
8. Don't allow the resin to dry all over the procedure.
9. Store the column at 4 °C. If you store for more than a week, add 5 ml PBST-0.02 % NaN₃ to avoid contamination.

References

1. Dwyer JM (1992) Manipulating the immune system with immune globulin. *N Engl J Med* 326:107-116
2. Bayry J, Thirion M, Misra N et al (2003) Mechanisms of action of intravenous immunoglobulin in autoimmune and inflammatory diseases. *Neurol Sci* 24:S217-S221
3. Kazatchkine MD, Kaveri SV (2001) Immunomodulation of autoimmune and inflammatory diseases with intravenous immune globulin. *N Engl J Med* 345:747-755
4. Dalakas MC (1997) Intravenous immune globulin therapy for neurologic diseases. *Ann Intern Med* 126:721-730
5. Sherer Y, Levy Y, Shoenfeld Y (2002) IVIG in autoimmunity and cancer—efficacy versus safety. *Expert Opin Drug Saf* 1:153-158
6. Kazatchkine MD (1990) Anti-idiotypic suppression of autoantibodies with high dose intravenous immunoglobulins. *Prog Clin Biol Res* 337:411-414
7. Omwandho CO, Gruessner SE, Roberts TK, Tinneberg HR (2004) Intravenous immunoglobulin (IVIG): modes of action in the clinical management of recurrent pregnancy loss (RPL) and selected autoimmune disorders. *Clin Chem Lab Med* 42:359-370
8. Sultan Y, Kazatchkine MD, Maissonneuve P, Nydegger UE (1984) Anti-idiotypic suppression of autoantibodies to factor VII (antihemophilic factor) by high-dose intravenous immunoglobulin. *Lancet* 2:765-768
9. Schroeder JO, Zeuner RA, Euler HH, Löffler H (1996) High dose intravenous immunoglobulins in systemic lupus erythematosus: clinical and serological results of a pilot study. *J Rheumatol* 23:71-75
10. Evans MJ, Suenaga R, Abdou NI (1991) Detection and purification of anti-idiotypic antibody against anti-DNA in intravenous immune globuline. *J Clin Immunopathol* 11:291-295
11. Rossi F, Kazatchkine MD (1989) Anti-idiotypes against autoantibodies in pooled normal human polyspecific Ig. *J Immunol* 143:4104-4109
12. Rossi F, Jayne DR, Lockwood CM, Kazatchkine MD (1991) Anti-idiotypes against anti-neutrophil cytoplasmic antigen autoantibodies in

- normal human polyspecific IgG for therapeutic use and in the remission sera of patients with systemic vasculitis. *Clin Exp Immunol* 83:298–303
13. Tandon N, Jayne DR, McGregor AM, Weetman AP (1992) Analysis of anti-idiotypic antibodies against anti-microsomal antibodies in patients with thyroid autoimmunity. *J Autoimmun* 5:557–570
 14. Lundkvist I, van Doorn PA, Vermeulen M, Brand A (1993) Spontaneous recovery from the Guillain-Barre syndrome is associated with anti-idiotypic antibodies recognizing a cross-reactive idiotype on anti-neuroblastoma cell line antibodies. *Clin Immunol Immunopathol* 67:192–198
 15. Caccavo D, Vaccaro F, Ferri GM et al (1994) Anti-idiotypes against antiphospholipid antibodies are present in normal polyspecific immunoglobulins for therapeutic use. *J Autoimmun* 7:537–548
 16. Mehta YS, Badakere SS (1996) In-vitro inhibition of antiplatelet autoantibodies by intravenous immunoglobulins and Rh immunoglobulins. *J Postgrad Med* 42:46–49
 17. DeKeyser F, DeKeyser H, Kazatchkine MD et al (1996) Pooled human immunoglobulins contain anti-idiotypes with reactivity against the SLE-associated 4B4 cross-reactive idiotype. *Clin Exp Rheumatol* 14:587–591
 18. Yuki N, Miyagi F (1996) Possible mechanism of intravenous immunoglobulin treatment on anti-GM1 antibody-mediated neuropathies. *J Neurol Sci* 139:160–162
 19. Silvestris F, Cafforio P, Dammacco F (1994) Pathogenic anti-DNA idiotype-reactive IgG in intravenous immunoglobulin preparations. *Clin Exp Immunol* 97:19–25
 20. Evans M, Abdou NI (1993) In vitro modulation of anti-DNA secreting peripheral blood mononuclear cells of lupus patients by anti-idiotypic antibody of pooled human intravenous immune globulin. *Lupus* 2:371–375
 21. Shoenfeld Y, Rauova L, Gilburd B et al (2002) Efficacy of IVIG affinity-purified anti-double-stranded DNA anti-idiotypic antibodies in the treatment of an experimental murine model of systemic lupus erythematosus. *Int Immunol* 14:1303–1311
 22. Blank M, Anafi L, Zandman-Goddard G et al (2007) The efficacy of specific IVIG anti-idiotypic antibodies in antiphospholipid syndrome (APS): trophoblast invasiveness and APS animal model. *Int Immunol* 19:857–865
 23. Mimouni D, Blank M, Payne AS et al (2010) Efficacy of intravenous immunoglobulin (IVIG) affinity-purified anti-desmoglein anti-idiotypic antibodies in the treatment of an experimental model of pemphigus vulgaris. *Clin Exp Immunol* 162:543–549
 24. Svetlicky N, Ortega OD, Mouthon L et al (2013) The advantage of specific intravenous immunoglobulin (sIVIG) on regular IVIG: experience of the last decade. *J Clin Immunol* 33(Suppl 1):S27–S32
 25. Blank M, Nur I, Toub O et al (2005) Toward molecular targeting with specific intravenous immunoglobulin preparation. *Clin Rev Allergy Immunol* 29:213–217

INDEX

A

- Adjuvanticity2
 ADLib system. *See* Autonomously Diversifying Library (ADLib) system
 Affinity chromatography 143, 147, 183, 191, 206, 259, 266, 267, 269, 271, 332, 334, 336, 337, 341–346, 348, 349
 Antibody affinity22–23
 Antibody engineering..... 1, 3, 9, 10, 21, 124, 186
 Antibody fragment16, 19–21, 151, 171–183, 217, 221–222, 232, 234–235, 238, 239, 247, 277, 278, 291
 Antibody from human patients or vaccines19–20
 Antibody production19, 28, 212, 246, 249, 250, 264, 273, 277, 300, 301
 Antibody repertoire 24–26, 135, 150, 151, 158, 222
 Antigen..... 2, 10, 37, 61, 79, 112, 123, 139, 150, 185, 216, 245–273, 277, 297–306, 310, 354
 Anti-idiotype..... 3, 27, 62, 86, 88, 354, 356
 Autoimmune disease46, 47, 86, 87, 89, 93, 123, 216, 246, 353–360
 Autonomously Diversifying Library (ADLib) system..... 140–142

B

- B-cell immune response14
 Bevacizumab.....28, 64, 69–74, 90, 92, 95
 Biological limitation27
 Bispecific antibody.....185–212

C

- Cancer 10, 11, 13–15, 19–21, 24–27, 29, 39–41, 61–75, 80, 89, 90, 94–96, 99, 123, 134, 183, 185, 216, 246, 247, 257, 353, 354
 Cancer therapy 65, 75, 99, 172
 Cation-exchange chromatography.....342
 CDRs insertion into “scaffold”18–19
 Cell selection 12, 13, 24, 81, 112, 114, 116, 117
 Chimeric intermediate..... 18, 19
 Chimeric monoclonal antibody 18, 65, 66, 70, 91, 96
 CHX-A^mDTPA311, 312, 314, 318–320, 328
 Class switching.....21–22, 24
 Clinical and pre-clinical limitation.....23

- Conjugated antibody119, 291
 Continuous chromatography337–339
 Countercurrent chromatography336–340
 Crohn’s disease 38–42, 47–50, 53, 89–91, 247

D

- Diagnostics 9–11, 20, 21, 27, 30, 31, 63, 176, 215, 216, 245
 Diploid112
 Downstream processing.....332
 DT40 cell140–142, 144, 145, 147

E

- Effector function limitation.....28–29
 Epstein Barr virus..... 111–122
 Ethical limitation 9–32, 297

G

- Gene targeting..... 140, 148, 249, 251

H

- High dose tolerance.....4
 High-throughput..... 12, 17, 277
 Human B-cells, source.....15
 Humanized antibody..... 18, 95, 124–136
 Humanizing via chimeric intermediate18
 Human lymphocytes, source.....15
 Hybridoma 11, 12, 37, 38, 61, 87, 124, 139, 140, 150, 151, 153, 171, 216, 247, 248, 250, 254, 255, 258, 262–268, 270, 271, 277
 Hydrophobic interaction chromatography335

I

- Immortalization..... 11, 113, 120
 Immune ecology14–15
 Immune library..... 236, 237
 Immunogenicity1–7, 12, 17, 38, 62, 67, 88, 94, 98, 124–126, 129, 130, 133–135, 139, 172, 182, 246, 247, 271, 272
 Immunoglobulin transgene.....248
 Immunomodulation..... 42, 82, 353, 354
 Indium-111 (¹¹¹In).....311, 312, 314, 318–320
 Inflammatory disease..... 37–54, 89, 91, 93

Informed consent29–32
 Intravenous immunoglobulin (IVIG) 26, 81–88,
 98, 353–360
 specific353–360
 In vitro immunization (IVI)297–306
 In vitro selection 151, 156, 216
 Isotype 10, 20–22, 24, 97, 112, 114,
 119, 150, 265–267, 273
 IVI. *See* In vitro immunization (IVI)
 IVIG. *See* Intravenous immunoglobulin (IVIG)

K

Knockout mice87, 249–251, 253, 254, 258

L

Library of monoclonal antibody 140, 298
 Limitations of manufacturing 11, 22–29
 Lymph node 11, 15, 23–27, 87, 95, 112
 Lymphoblastoid cell line 113, 115

M

Maltose-binding protein (MBP)172, 173, 175, 177,
 179–183
 Manufacturing11, 17, 27, 32, 331
 MBP. *See* Maltose-binding protein (MBP)
 MCSGP. *See* Multicolumn countercurrent solvent gradient
 purification (MCSGP)
 Migrating B-cell15
 Multicolumn countercurrent solvent gradient
 purification (MCSGP) 338, 339, 347–350

N

Naive library 222, 223, 225, 236
 Natural antibody 13–14, 24, 26, 29, 32,
 80, 81, 151, 159, 165
 Nature’s experiment,29
 Niche habitats214–215

P

Panning216, 221, 232–238, 279
 Passive immunization 29, 80, 113
 Patient information, tracing32
 Phage display11, 16, 19, 88, 150, 151, 153, 155–158,
 162–165, 190, 215–239, 247, 277–294, 304
 Polyclonal antibody 2, 79–99, 245, 353
 Posttranslational modification 27, 215, 332, 333
 Preparative chromatography340
 Production cost27–28, 97
 Protein A 191, 206–207, 212, 259, 267–269,
 272, 273, 332, 334, 336, 340–350
 Protein engineering20
 Protein expression 112, 174, 181, 183, 231, 238
 Psoriasis38–41, 48, 51–53, 89, 90, 92–93, 247, 256

Psoriatic arthritis38–41, 48, 51–53, 256
 Purification 21, 27, 125, 131, 141, 147, 157,
 159–162, 165, 167, 172–183, 187, 189, 190,
 195–196, 205–207, 209, 210, 212, 217, 228, 229,
 258, 259, 265–269, 272, 273, 281, 283, 293, 312,
 315–316, 331–350, 355–359

R

Radioiodination
 direct 311–313, 316–317
 indirect 311–313, 317–318
 Recombinant antibody 17, 98, 171, 172, 186, 215
 Rheumatoid arthritis (RA)38–47, 51, 53, 65,
 66, 82, 89, 90, 93, 123, 247, 256, 257
 Rituximab 27, 43–47, 64–66, 68, 69, 90, 93, 96
 RNA processing 19, 141, 292

S

scFv. *See* Single-chain fragment variable (scFv)
 Screening limitation28
 SEC. *See* Size-exclusion chromatography (SEC)
 Single-chain fragment variable (scFv) 19–21,
 151, 157, 158, 171–183, 186, 188–190, 193, 194,
 196, 209–211, 217, 221–223, 231, 232, 236, 238,
 239, 246, 247, 278, 279, 282, 283, 290–292, 358
 Size-exclusion chromatography (SEC) 126, 131–132,
 181, 183, 193, 334–335, 340, 345, 346
 Stability17, 21, 125–127, 129–131,
 133, 134, 153, 165, 167, 172, 177, 183, 190,
 194, 204, 271
 Synthetic antibody16, 27, 29, 165–169
 Synthetic library17, 26, 27, 150, 158,
 165, 222, 223

T

Technical limitation9–32
 TEV. *See* Tobacco etch virus (TEV)
 Therapeutic antibody2, 4, 5, 7, 17, 27,
 28, 63, 97, 125, 215–217
 Therapeutics 1–6, 9–11, 14, 16, 17, 20, 21,
 27, 28, 30, 37–54, 61–75, 81, 85, 88, 90, 95,
 97–99, 124, 139, 150, 151, 171, 182, 185, 216,
 245, 250, 272, 297, 353
 Tobacco etch virus (TEV)172, 173, 175–177,
 180–183
 Transgenic mice38, 88, 171, 216, 245–273
 Transloci bearing human Ig gene 246, 250–254,
 258, 273
 Trastuzumab28, 63, 64, 71, 72, 90, 95, 216, 327
 Trichostatin A (TSA) 140, 142, 145

Y

YAC-based human Ig transloci 248, 249