

## A Note on the TU Dresden IAC-21 paper

In the latest TU Dresden paper on EmDrive research [1], fig. 3 shows the basic geometry of the cavity. The cavity has a flat small end plate and a spherical large end plate.

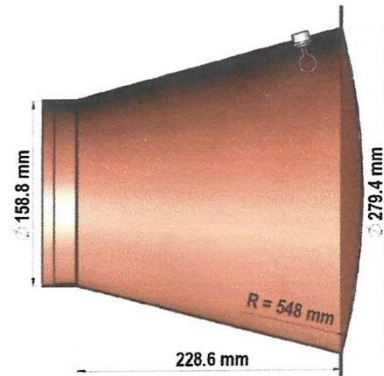
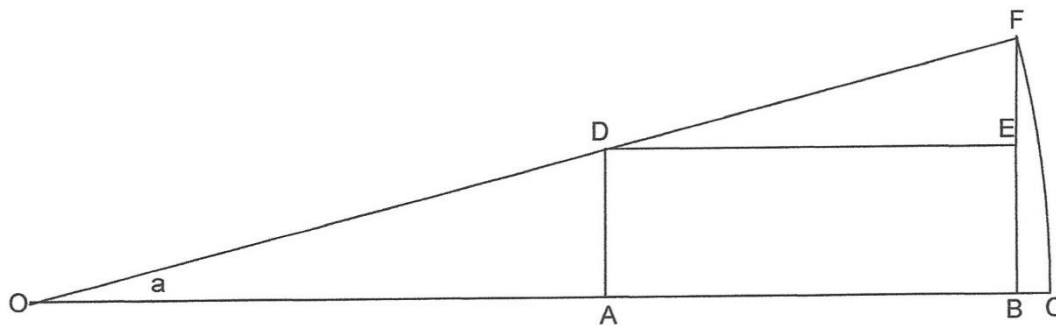

Fig. 3: Geometrical dimensions of the copper cavity with a spherical end-cap at the large diameter.

Applying simple trigonometry to the cavity design:



$$EF = \frac{279.4}{2} - \frac{158.8}{2} = 60.3 \text{ mm}$$

$$\tan a = \frac{EF}{DE} \quad \text{Then } \tan a = \frac{60.3}{228.6} \quad \text{Then } a = 14.78 \text{ deg}$$

$$\sin a = \frac{EF}{DF} \quad \text{Then } DF = 236.37 \quad \text{i.e. Path length along side-wall} = 236.37 \text{ mm}$$

$$AD = \frac{158.8}{2} = 79.4$$

$$\tan a = \frac{AD}{OA} \quad \text{Then } OA = 300.94$$

$$AC = 548 - OA \quad \text{Then } AC = 247.06 \quad \text{i.e. Path length along axis} = 247.06 \text{ mm}$$

$$\text{Then path length difference for one EM transit} = 247.06 - 236.37 = 10.69$$

Assume TMO12 mode [2] and one wavelength = AC

Then phase distortion across wave-front for one transit =  $\frac{10.69}{247.06} = .043$

Then max number of transits before one half wavelength distortion occurs =  $\frac{1}{.043 \times 2} = 11.63$

This represents the maximum possible Q for the cavity, although at this point, path angles are no longer orthogonal to end plates and significant side wall reflection will take place.

The cavity will clearly be incapable of resonating correctly as a travelling wave cavity, and therefore will not produce any thrust according to the theory of EmDrive operation.

R J Shawyer

5 November 2021

#### References

1. Thrust Measurements of Microwave, Superconducting and Laser Type EmDrives.

O. Neunzig M. Weikart M. Tajmar

IAC-21,C4,10-C3.5,1 x63502

2. Notes on Dresden SP2020+1 EmDrive paper

R. Shawyer April 2021 [www.emdrive.com](http://www.emdrive.com)