

### 3. The Motion of Rigid Bodies



**Figure 22:** Wolfgang Pauli and Niels Bohr stare in wonder at a spinning top.

Having now mastered the technique of Lagrangians, this section will be one big application of the methods. The systems we will consider are the spinning motions of extended objects. As we shall see, these can often be counterintuitive. Certainly Pauli and Bohr found themselves amazed!

We shall consider extended objects that don't have any internal degrees of freedom. These are called "rigid bodies", defined to be a collection of  $N$  points constrained so that the distance between the points is fixed. i.e.

$$|\mathbf{r}_i - \mathbf{r}_j| = \text{constant} \quad (3.1)$$

for all  $i, j = 1, \dots, N$ . A simple example is a dumbbell (two masses connected by a light rod), or the pyramid drawn in the figure. In both cases, the distances between the masses is fixed.

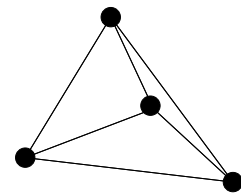

**Figure 23:**

Often we will work with continuous, rather than discrete, bodies simply by replacing  $\sum_i m_i \rightarrow \int d\mathbf{r} \rho(\mathbf{r})$  where  $\rho(\mathbf{r})$  is the density of the object. A rigid body has six degrees of freedom

### 3 Translation + 3 Rotation

The most general motion of a free rigid body is a translation plus a rotation about some point  $P$ . In this section we shall develop the techniques required to describe this motion.

#### 3.1 Kinematics

Consider a body fixed at a point  $P$ . The most general allowed motion is a rotation about  $P$ . To describe this, we specify positions in a *fixed space frame*  $\{\tilde{\mathbf{e}}_a\}$  by embedding a *moving body frame*  $\{\mathbf{e}_a\}$  in the body so that  $\{\mathbf{e}_a\}$  moves with the body.

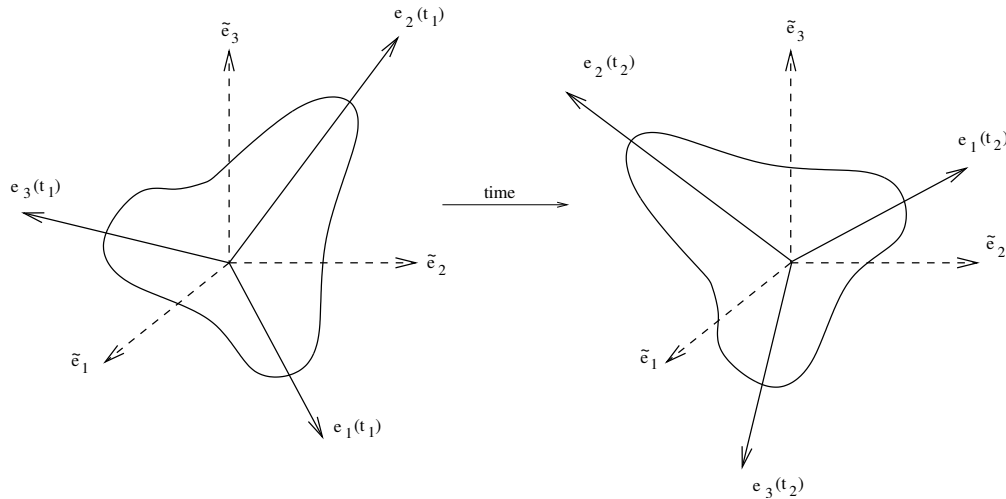

**Figure 24:** The fixed space frame and the moving body frame.

Both axes are orthogonal, so we have

$$\tilde{\mathbf{e}}_a \cdot \tilde{\mathbf{e}}_b = \delta_{ab} \quad , \quad \mathbf{e}_a(t) \cdot \mathbf{e}_b(t) = \delta_{ab} \quad (3.2)$$

We will soon see that there is a natural choice of the basis  $\{\mathbf{e}_a\}$  in the body.

**Claim:** For all  $t$ , there exists a unique orthogonal matrix  $R(t)$  with components  $R_{ab}(t)$  such that  $\mathbf{e}_a(t) = R_{ab}(t)\tilde{\mathbf{e}}_b$

**Proof:**  $\mathbf{e}_a \cdot \mathbf{e}_b = \delta_{ab} \Rightarrow R_{ac}R_{bd}\tilde{\mathbf{e}}_c \cdot \tilde{\mathbf{e}}_d = \delta_{ab} \Rightarrow R_{ac}R_{bc} = \delta_{ab}$  or, in other words,  $(R^T R)_{ab} = \delta_{ab}$  which is the statement that  $R$  is orthogonal. The uniqueness of  $R$  follows by construction:  $R_{ab} = \mathbf{e}_a \cdot \tilde{\mathbf{e}}_b$ .  $\square$

So as the rigid body rotates it is described by a time dependent orthogonal  $3 \times 3$  matrix  $R(t)$ . This matrix also has the property that its determinant is 1. (The other possibility is that its determinant is  $-1$  which corresponds to a rotation and a reflection  $\mathbf{e}_a \rightarrow -\mathbf{e}_a$ ). Conversely, every one-parameter family  $R(t)$  describes a possible motion of the body. We have

$$C = \text{Configuration Space} = \text{Space of } 3 \times 3 \text{ Special Orthogonal Matrices} \equiv SO(3)$$

A  $3 \times 3$  matrix has 9 components but the condition of orthogonality  $R^T R = 1$  imposes 6 relations, so the configuration space  $C$  is 3 dimensional and we need 3 generalised coordinates to parameterise  $C$ . We shall describe a useful choice of coordinates, known as Euler angles, in section 3.5.

### 3.1.1 Angular Velocity

Any point  $\mathbf{r}$  in the body can be expanded in either the space frame or the body frame:

$$\begin{aligned} \mathbf{r}(t) &= \tilde{r}_a(t) \tilde{\mathbf{e}}_a && \text{in the space frame} \\ &= r_a \mathbf{e}_a(t) && \text{in the body frame} \end{aligned} \quad (3.3)$$

where  $\tilde{r}_b(t) = r_a R_{ab}(t)$ . Taking the time derivative, we have

$$\begin{aligned} \frac{d\mathbf{r}}{dt} &= \frac{d\tilde{r}_a}{dt} \tilde{\mathbf{e}}_a && \text{in the space frame} \\ &= r_a \frac{d\mathbf{e}_a(t)}{dt} && \text{in the body frame} \\ &= r_a \frac{dR_{ab}}{dt} \tilde{\mathbf{e}}_b \end{aligned} \quad (3.4)$$

Alternatively, we can ask how the body frame basis itself changes with time,

$$\frac{d\mathbf{e}_a}{dt} = \frac{dR_{ab}}{dt} \tilde{\mathbf{e}}_b = \frac{dR_{ab}}{dt} R_{bc}^{-1} \mathbf{e}_c \equiv \omega_{ac} \mathbf{e}_c \quad (3.5)$$

where, in the last equality, we have defined  $\omega_{ac} = \dot{R}_{ab}(R^{-1})_{bc} = \dot{R}_{ab}R_{cb}$  using the fact that  $R^T R = 1$ .

**Claim:**  $\omega_{ac} = -\omega_{ca}$  i.e.  $\omega$  is antisymmetric.

**Proof:**  $R_{ab}R_{cb} = \delta_{ac} \Rightarrow \dot{R}_{ab}R_{cb} + R_{ab}\dot{R}_{cb} = 0 \Rightarrow \omega_{ac} + \omega_{ca} = 0$  □

Since  $\omega_{ac}$  is antisymmetric, we can use it to define an object with a single index (which we will also call  $\boldsymbol{\omega}$ ) using the formula

$$\omega_a = \frac{1}{2}\epsilon_{abc}\omega_{bc} \quad (3.6)$$

so that  $\omega_3 = \omega_{12}$  and so on. We treat these  $\omega_a$  as the components of a vector *in the body frame*, so  $\boldsymbol{\omega} = \omega_a \mathbf{e}_a$ . Then finally we have our result for the change of the body frame basis with time

$$\frac{d\mathbf{e}_a}{dt} = -\epsilon_{abc}\omega_b \mathbf{e}_c = \boldsymbol{\omega} \times \mathbf{e}_a \quad (3.7)$$

where, in the second equality, we have used the fact that our body frame axis has a “right-handed” orientation, meaning  $\mathbf{e}_a \times \mathbf{e}_b = \epsilon_{abc}\mathbf{e}_c$ . The vector  $\boldsymbol{\omega}$  is called the *instantaneous angular velocity* and its components  $\omega_a$  are measured with respect to the body frame.

Since the above discussion was a little formal, let’s draw a picture to uncover the physical meaning of  $\boldsymbol{\omega}$ . Consider a displacement of a given point  $\mathbf{r}$  in the body by rotating an infinitesimal amount  $d\phi$  about an axis  $\hat{\mathbf{n}}$ . From the figure, we see that  $|d\mathbf{r}| = |\mathbf{r}| d\phi \sin \theta$ . Moreover, this displacement is perpendicular to  $\mathbf{r}$  since the distance to  $P$  is fixed by the definition of a rigid body. So we have

$$d\mathbf{r} = d\boldsymbol{\phi} \times \mathbf{r} \quad (3.8)$$

with  $d\boldsymbol{\phi} = \hat{\mathbf{n}}d\phi$ . “Dividing” this equation by  $dt$ , we have the result

$$\dot{\mathbf{r}} = \boldsymbol{\omega} \times \mathbf{r} \quad (3.9)$$

where  $\boldsymbol{\omega} = d\boldsymbol{\phi}/dt$  is the instantaneous angular velocity. In general, both the axis of rotation  $\hat{\mathbf{n}}$  and the rate of rotation  $d\phi/dt$  will change over time.

**Aside:** One could define a slightly different type of angular velocity by looking at how the space frame coordinates  $\tilde{r}_a(t)$  change with time, rather than the body frame axes  $\mathbf{e}_a$ . Since we have  $\tilde{r}_b(t) = r_a R_{ab}(t)$ , performing the same steps as above, we have

$$\dot{\tilde{r}}_b = r_a \dot{R}_{ab} = \tilde{r}_a (R^{-1} \dot{R})_{ab} \quad (3.10)$$

which tempts us to define a different type of angular velocity, sometimes referred to as “convective angular velocity” by  $\Omega_{ab} = R_{ac}^{-1} \dot{R}_{cb}$  which has the  $R^{-1}$  and  $\dot{R}$  in a different order. Throughout our discussion of rigid body motion, we will only deal with the original  $\boldsymbol{\omega} = \dot{R}R^{-1}$ .

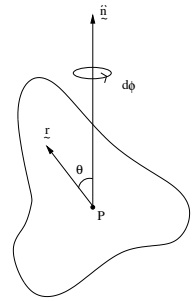

**Figure 25:**

### 3.1.2 Path Ordered Exponentials

In the remainder of this chapter, we will devote much effort to determine the angular velocity vector  $\boldsymbol{\omega}(t)$  of various objects as they spin and turn. But how do we go from this to the rotation  $R(t)$ ? As described above, we first turn the vector  $\boldsymbol{\omega} = w_a \mathbf{e}_a$  into a  $3 \times 3$  antisymmetric matrix  $\omega_{ab} = \epsilon_{abc} \omega_c$ . Then, from this, we get the rotation matrix  $R$  by solving the differential equation

$$\boldsymbol{\omega} = \frac{dR}{dt} R^{-1} \quad (3.11)$$

If  $\boldsymbol{\omega}$  and  $R$  were scalar functions of time, then we could simply integrate this equation to get the solution

$$R(t) = \exp \left( \int_0^t \boldsymbol{\omega}(t') dt' \right) \quad (3.12)$$

which satisfies the initial condition  $R(0) = 1$ . But things are more complicated because both  $\boldsymbol{\omega}$  and  $R$  are matrices. Let's first describe how we take the exponential of a matrix. This is defined by the Taylor expansion. For any matrix  $M$ , we have

$$\exp(M) \equiv 1 + M + \frac{1}{2}M^2 + \dots \quad (3.13)$$

As our first guess for the solution to the matrix equation (3.11), we could try the scalar solution (3.12) and look at what goes wrong. If we take the time derivative of the various terms in the Taylor expansion of this putative solution, then problems first arise when we hit the  $\frac{1}{2}M^2$  type term. The time derivative of this reads

$$\frac{1}{2} \frac{d}{dt} \left( \int_0^t \boldsymbol{\omega}(t') dt' \right)^2 = \frac{1}{2} \boldsymbol{\omega}(t) \left( \int_0^t \boldsymbol{\omega}(t') dt' \right) + \frac{1}{2} \left( \int_0^t \boldsymbol{\omega}(t') dt' \right) \boldsymbol{\omega}(t) \quad (3.14)$$

We would like to show that  $\dot{R} = \boldsymbol{\omega}R$ . The first term on the right-hand side looks good since it appears in the Taylor expansion of  $\boldsymbol{\omega}R$ . But the second term isn't right. The problem is that we cannot commute  $\boldsymbol{\omega}(t)$  past  $\boldsymbol{\omega}(t')$  when  $t' \neq t$ . For this reason, equation (3.12) is *not* the solution to (3.11) when  $\boldsymbol{\omega}$  and  $R$  are matrices. But it does give us a hint about how we should proceed. Since the problem is in the ordering of the matrices, the correct solution to (3.11) takes a similar form as (3.12), but with a different ordering. It is the *path ordered exponential*,

$$R(t) = P \exp \left( \int_0^t \boldsymbol{\omega}(t') dt' \right) \quad (3.15)$$

where the  $P$  in front means that when we Taylor expand the exponential, all matrices are ordered so that later times appear on the left. In other words

$$R(t) = 1 + \int_0^t \omega(t') dt' + \int_0^{t''} \int_{t'}^t \omega(t'') \omega(t') dt' dt'' + \dots \quad (3.16)$$

The double integral is taken over the range  $0 < t' < t'' < t$ . If we now differentiate this double integral with respect to  $t$ , we get just the one term  $\omega(t) \left( \int_0^t \omega(t') dt' \right)$ , instead of the two that appear in (3.14). It can be checked that the higher terms in the Taylor expansion also have the correct property if they are ordered so that matrices evaluated at later times appear to the left in the integrals. This type of path ordered integral comes up frequently in theories involving non-commuting matrices, including the standard model of particle physics.

As an aside, the rotation matrix  $R$  is a member of the Lie group  $SO(3)$ , the space of  $3 \times 3$  orthogonal matrices with unit determinant. The antisymmetric angular velocity matrix  $\omega$ , corresponding to an instantaneous, infinitesimal rotation, lives in the Lie algebra  $so(3)$ .

### 3.2 The Inertia Tensor

Let's look at the kinetic energy for a rotating body. We can write

$$\begin{aligned} T &= \frac{1}{2} \sum_i m_i \dot{\mathbf{r}}_i^2 \\ &= \frac{1}{2} \sum_i m_i (\boldsymbol{\omega} \times \mathbf{r}_i) \cdot (\boldsymbol{\omega} \times \mathbf{r}_i) \\ &= \frac{1}{2} \sum_i m_i ((\boldsymbol{\omega} \cdot \boldsymbol{\omega})(\mathbf{r}_i \cdot \mathbf{r}_i) - (r_i \cdot \boldsymbol{\omega})^2) \end{aligned} \quad (3.17)$$

Or, in other words, we can write the kinetic energy of a rotating body as

$$T = \frac{1}{2} \omega_a I_{ab} \omega_b \quad (3.18)$$

where  $I_{ab}$ ,  $a, b = 1, 2, 3$  are the components of the *inertia tensor* measured in the body frame, defined by

$$I_{ab} = \sum_i m_i ((\mathbf{r}_i \cdot \mathbf{r}_i) \delta_{ab} - (\mathbf{r}_i)_a (\mathbf{r}_i)_b) \quad (3.19)$$

Note that  $I_{ab} = I_{ba}$  so the inertia tensor is symmetric. Moreover, the components are independent of time since they are measured with respect to the body frame. For

continuous bodies, we have the analogous expression

$$I = \int d^3\mathbf{r} \rho(\mathbf{r}) \begin{pmatrix} y^2 + z^2 & -xy & -xz \\ -xy & x^2 + z^2 & -yz \\ -xz & -yz & x^2 + y^2 \end{pmatrix} \quad (3.20)$$

Since  $I_{ab}$  is a symmetric real matrix, we can diagonalise it. This means that there exists an orthogonal matrix  $O$  such that  $OIO^T = I'$  where  $I'$  is diagonal. Equivalently, we can rotate the body frame axis  $\{\mathbf{e}_a\}$  to coincide with the eigenvectors of  $I$  (which are  $\{O\mathbf{e}_a\}$ ) so that, in this frame, the inertia tensor is diagonal. These preferred body axes, in which  $I$  is diagonal, are called the *principal axes*. In this basis,

$$I = \begin{pmatrix} I_1 & & \\ & I_2 & \\ & & I_3 \end{pmatrix} \quad (3.21)$$

The eigenvalues  $I_a$  are called the *principal moments of inertia*. The kinematical properties of a rigid body are fully determined by its mass, principal axes, and moments of inertia. Often the principal axes are obvious by symmetry.

**Claim:** The  $I_a$  are real and positive.

**Proof:** If  $\mathbf{c}$  is an arbitrary vector, then

$$I_{ab}c^a c^b = \sum_i m_i (r_i^2 c^2 - (\mathbf{r}_i \cdot \mathbf{c})^2) \geq 0 \quad (3.22)$$

with equality only if all the  $\mathbf{r}_i$  lie on a line. If  $\mathbf{c}$  is the  $a^{\text{th}}$  eigenvector of  $I$  then this result becomes  $I_{ab}c^a c^b = I_a |\mathbf{c}|^2$  which tells us  $I_a \geq 0$ .  $\square$

### Example: The Rod

Consider the inertia tensor of a uniform rod of length  $l$  and mass  $M$  about its centre. The density of the rod is  $\rho = M/l$ . By symmetry, we have  $I = \text{diag}(I_1, I_1, 0)$  where

$$I_1 = \int_{-l/2}^{l/2} \rho x^2 dx = \frac{1}{12} M l^2 \quad (3.23)$$

### Example: The Disc

Now consider a uniform disc of radius  $r$  and mass  $M$ . We take the  $z$  axis to be perpendicular to the disc and measure  $I$  about its centre of mass. Again we know that  $I = \text{diag}(I_1, I_2, I_3)$ . The density of the disc is  $\rho = M/\pi r^2$ , so we have

$$I_1 = \int \rho y^2 d^2x \quad , \quad I_2 = \int \rho x^2 d^2x$$

so  $I_1 = I_2$  by symmetry, while

$$I_3 = \int \rho(x^2 + y^2) d^2x$$

Therefore

$$I_3 = I_1 + I_2 = 2\pi\rho \int_0^r r'^3 dr' = \frac{1}{2}Mr^2 \quad (3.24)$$

So the moments of inertia are  $I_1 = I_2 = \frac{1}{4}Mr^2$  and  $I_3 = \frac{1}{2}Mr^2$ .

#### 3.2.1 Parallel Axis Theorem

The inertia tensor depends on what point  $P$  in the body is held fixed. In general, if we know  $I$  about a point  $P$  it is messy to compute it about some other point  $P'$ . But it is very simple if  $P$  happens to coincide with the centre of mass of the object.

**Claim:** If  $P'$  is displaced by  $\mathbf{c}$  from the centre of mass, then

$$(I_{\mathbf{c}})_{ab} = (I_{c.of.m})_{ab} + M(c^2\delta_{ab} - \mathbf{c}_a\mathbf{c}_b) \quad (3.25)$$

**Proof:**

$$\begin{aligned} (I_{\mathbf{c}})_{ab} &= \sum_i m_i \{ (\mathbf{r}_i - \mathbf{c})^2 \delta_{ab} - (\mathbf{r}_i - \mathbf{c})_a (\mathbf{r}_i - \mathbf{c})_b \} \\ &= \sum_i m_i \{ r_i^2 \delta_{ab} - (\mathbf{r}_i)_a (\mathbf{r}_i)_b + [-2\mathbf{r}_i \cdot \mathbf{c} \delta_{ab} + (\mathbf{r}_i)_a \mathbf{c}_b + (\mathbf{r}_i)_b \mathbf{c}_a] + (c^2 \delta_{ab} - \mathbf{c}_a \mathbf{c}_b) \} \end{aligned} \quad (3.26)$$

But the terms in square brackets that are linear in  $\mathbf{r}_i$  vanish if  $\mathbf{r}_i$  is measured from the centre of mass since  $\sum_i m_i \mathbf{r}_i = 0$ .  $\square$

The term  $M(c^2\delta_{ab} - \mathbf{c}_a\mathbf{c}_b)$  is the inertia tensor we would find if the whole body was concentrated at the centre of mass.

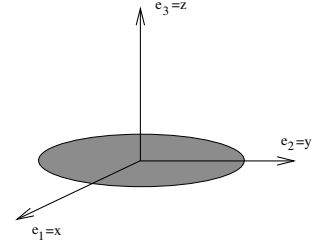

**Figure 26:**



### Example: The Rod Again

The inertia tensor of the rod about one of its ends is  $I_1 = \frac{1}{12}Ml^2 + M(l/2)^2 = \frac{1}{3}Ml^2$ .

### Example: The Disc Again

Consider measuring the inertia tensor of the disc about a point displaced by  $\mathbf{c} = (c, 0, 0)$  from the centre. We have

$$\begin{aligned} I_{\mathbf{c}} &= M \begin{pmatrix} \frac{1}{4}r^2 & & \\ & \frac{1}{4}r^2 & \\ & & \frac{1}{2}r^2 \end{pmatrix} + M \left[ \begin{pmatrix} c^2 & & \\ & c^2 & \\ & & c^2 \end{pmatrix} - \begin{pmatrix} c^2 & & \\ & 0 & \\ & & 0 \end{pmatrix} \right] \\ &= M \begin{pmatrix} \frac{1}{4}r^2 & & \\ & \frac{1}{4}r^2 + c^2 & \\ & & \frac{1}{2}r^2 + c^2 \end{pmatrix} \end{aligned}$$

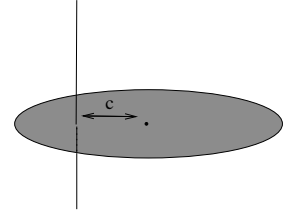

Figure 27:

### 3.2.2 Angular Momentum

The angular momentum  $\mathbf{L}$  about a point  $P$  can also be described neatly in terms of the inertia tensor. We have

$$\begin{aligned} \mathbf{L} &= \sum_i m_i \mathbf{r}_i \times \dot{\mathbf{r}}_i \\ &= \sum_i m_i \mathbf{r}_i \times (\boldsymbol{\omega} \times \mathbf{r}_i) \\ &= \sum_i m_i (r_i^2 \boldsymbol{\omega} - (\boldsymbol{\omega} \cdot \mathbf{r}_i) \mathbf{r}_i) \\ &= I \boldsymbol{\omega} \end{aligned} \tag{3.27}$$

In the body frame, we can write  $\mathbf{L} = L_a \mathbf{e}_a$  to get

$$L_a = I_{ab} \omega_b \tag{3.28}$$

where  $\boldsymbol{\omega} = \omega_a \mathbf{e}_a$ . Note that in general,  $\boldsymbol{\omega}$  is *not* equal to  $\mathbf{L}$ : the spin of the body and its angular momentum point in different directions. This fact will lead to many of the peculiar properties of spinning objects.

### 3.3 Euler's Equations

So far we have been discussing the rotation of a body fixed at a point  $P$ . In this section we will be interested in the rotation of a free body suspended in space - for example, a satellite or the planets. Thankfully, this problem is identical to that of an object fixed at a point. Let's show why this is the case and then go on to analyse the motion.

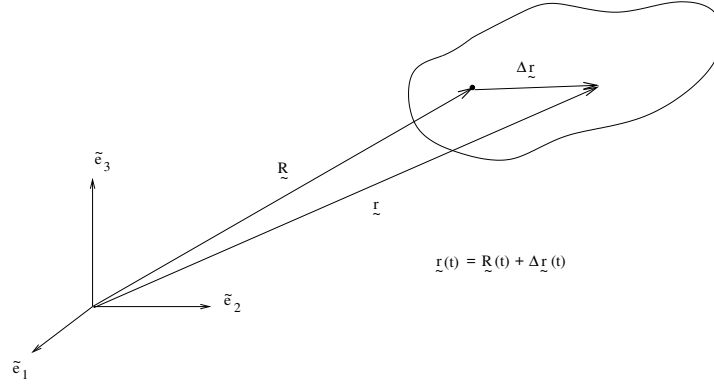

**Figure 28:**

The most general motion of a body is an overall translation superposed with a rotation. We could take this rotation to be about any point in the body (or, indeed, a point outside the body). But it is useful to consider the rotation to be about the center of mass. We can write the position of a particle in the body as

$$\mathbf{r}_i(t) = \mathbf{R}(t) + \Delta \mathbf{r}_i(t) \quad (3.29)$$

where  $\Delta \mathbf{r}_i$  is the position measured from the centre of mass. Then examining the kinetic energy (which, for a free body, is all there is)

$$\begin{aligned} T &= \frac{1}{2} \sum_i m_i \dot{\mathbf{r}}_i^2 \\ &= \sum_i m_i \left[ \frac{1}{2} \dot{\mathbf{R}}^2 + \dot{\mathbf{R}} \cdot (\boldsymbol{\omega} \times \Delta \mathbf{r}_i) + \frac{1}{2} (\boldsymbol{\omega} \times \Delta \mathbf{r}_i)^2 \right] \\ &= \frac{1}{2} M \dot{\mathbf{R}}^2 + \frac{1}{2} \boldsymbol{\omega}_a I_{ab} \boldsymbol{\omega}_b \end{aligned} \quad (3.30)$$

where we've used the fact that  $\sum_i m_i \Delta \mathbf{r}_i = 0$ . So we find that the dynamics separates into the motion of the centre of mass  $\mathbf{R}$ , together with rotation about the centre of mass. This is the reason that the analysis of the last section is valid for a free object.

### 3.3.1 Euler's Equations

From now on, we shall neglect the center of mass and concentrate on the rotation of the rigid body. Since the body is free, its angular momentum must be conserved. This gives us the vector equation

$$\frac{d\mathbf{L}}{dt} = 0 \quad (3.31)$$

Let's expand this in the body frame. we have

$$\begin{aligned} 0 &= \frac{d\mathbf{L}}{dt} = \frac{dL_a}{dt} \mathbf{e}_a + L_a \frac{d\mathbf{e}_a}{dt} \\ &= \frac{dL_a}{dt} \mathbf{e}_a + L_a \boldsymbol{\omega} \times \mathbf{e}_a \end{aligned} \quad (3.32)$$

This simplifies if we choose the body axes  $\{\mathbf{e}_a\}$  to coincide with the the principal axes. Using  $L_a = I_{ab}\omega_b$ , we can then write  $L_1 = I_1\omega_1$  and so on. The equations of motion (3.32) are now three non-linear coupled first order differential equations,

$$\begin{aligned} I_1\dot{\omega}_1 + \omega_2\omega_3(I_3 - I_2) &= 0 \\ I_2\dot{\omega}_2 + \omega_3\omega_1(I_1 - I_3) &= 0 \\ I_3\dot{\omega}_3 + \omega_1\omega_2(I_2 - I_1) &= 0 \end{aligned} \quad (3.33)$$

These are *Euler's Equations*.

We can extend this analysis to include a torque  $\boldsymbol{\tau}$ . The equation of motion becomes  $\dot{\mathbf{L}} = \boldsymbol{\tau}$  and we can again expand in the body frame along the principal axes to derive Euler's equations (3.33), now with the components of the torque on the RHS.

### 3.4 Free Tops

“To those who study the progress of exact science, the common spinning-top is a symbol of the labours and the perplexities of men.”

*James Clerk Maxwell, no less*

In this section, we'll analyse the motion of free rotating bodies (known as free tops) using Euler's equation.

We start with a trivial example: the sphere. For this object,  $I_1 = I_2 = I_3$  which means that the angular velocity  $\boldsymbol{\omega}$  is parallel to the angular momentum  $\mathbf{L}$ . Indeed, Euler's equations tell us that  $\omega_a$  is a constant in this case and the sphere continues to spin around the same axis you start it on. To find a more interesting case, we need to look at the next simplest object.

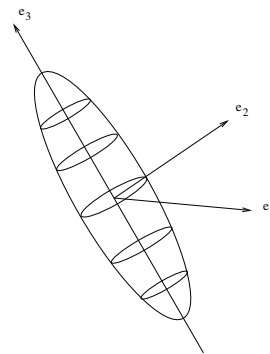
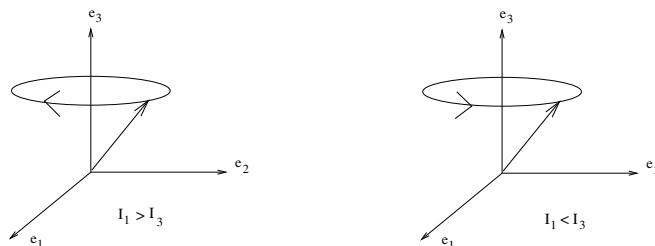

**Figure 29:**

#### 3.4.1 The Symmetric Top

The symmetric top is an object with  $I_1 = I_2 \neq I_3$ . A typical example is drawn in figure 29. Euler's equations become

$$\begin{aligned} I_1\dot{\omega}_1 &= \omega_2\omega_3(I_1 - I_3) \\ I_2\dot{\omega}_2 &= -\omega_1\omega_3(I_1 - I_3) \\ I_3\dot{\omega}_3 &= 0 \end{aligned} \quad (3.34)$$



**Figure 30:** The precession of the spin: the direction of precession depends on whether the object is short and fat ( $I_3 > I_1$ ) or tall and skinny ( $I_3 < I_1$ )

So, in this case, we see that  $\omega_3$ , which is the spin about the symmetric axis, is a constant of motion. In contrast, the spins about the other two axes are time dependent and satisfy

$$\dot{\omega}_1 = \Omega\omega_2 \quad , \quad \dot{\omega}_2 = -\Omega\omega_1 \quad (3.35)$$

where

$$\Omega = \omega_3(I_1 - I_3)/I_1 \quad (3.36)$$

is a constant. These equations are solved by

$$(\omega_1, \omega_2) = \omega_0(\sin \Omega t, \cos \Omega t) \quad (3.37)$$

for any constant  $\omega_0$ . This means that, in the body frame, the direction of the spin is not constant: it *precesses* about the  $\mathbf{e}_3$  axis with frequency  $\Omega$ . The direction of the spin depends on the sign on  $\Omega$  or, in other words, whether  $I_1 > I_3$  or  $I_1 < I_3$ . This is drawn in figure 30.

What does this look like in an inertial frame? The angular momentum  $\mathbf{L}$  is a fixed vector. But  $\omega^3$ , and hence  $L_3$ , are also fixed which ensures that the angle between  $\mathbf{e}_3$  and  $\mathbf{L}$  doesn't change in time. Instead,  $\mathbf{e}_3$  precesses around  $\mathbf{L}$ , while the body simultaneously spins such that  $\boldsymbol{\omega}$  remains between  $\mathbf{e}_3$  and  $\mathbf{L}$ . (If this is hard to visualise, then try searching YouTube for "free symmetric tops" or something similar and you will find [videos like this](#).) The fact that  $\boldsymbol{\omega}$  precesses around the body frame axis  $\mathbf{e}_3$  is sometimes referred to as a wobble.

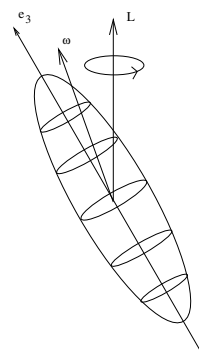

**Figure 31:**

### 3.4.2 Example: The Earth's Wobble

The spin of the earth causes it to bulge at the equator so it is no longer a sphere but can be treated as a symmetric top. It is an oblate ellipsoid, with  $I_3 > I_1$ , and is spherical to roughly 1 part in 300, meaning

$$\frac{I_1 - I_3}{I_1} \approx -\frac{1}{300} \quad (3.38)$$

Of course, we know the magnitude of the spin  $\omega_3$ : it is  $\omega_3 = (1 \text{ day})^{-1}$ . This information is enough to calculate the frequency of the earth's wobble; from (3.36), it should be

$$\Omega_{\text{earth}} = \frac{1}{300} \text{ day}^{-1} \quad (3.39)$$

This calculation was first performed by Euler in 1749 who predicted that the Earth completes a wobble every 300 days. Despite many searches, this effect wasn't detected until 1891 when Chandler re-analysed the data and saw a wobble with a period of 427 days. It is now known as the *Chandler wobble*. It is very small! The angular velocity  $\omega$  intercepts the surface of the earth approximately 10 metres from the North pole and precesses around it. More recent measurements place the frequency at 435 days, with the discrepancy between the predicted 300 days and observed 435 days due to the fact that the Earth is not a rigid body, but is flexible because of tidal effects. Less well understood is why these same tidal effects haven't caused the wobble to dampen and disappear completely. There are various theories about what keeps the wobble alive, from earthquakes to fluctuating pressure at the bottom of the ocean.

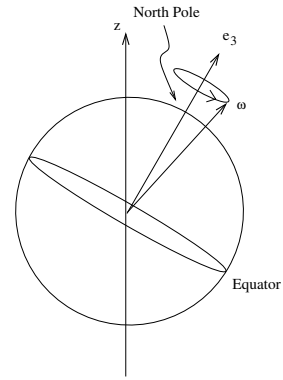

**Figure 32:**

### 3.4.3 The Asymmetric Top: Stability

The most general body has no symmetries and  $I_1 \neq I_2 \neq I_3 \neq I_1$ . The rotational motion is more complicated but there is a simple result that we will describe here. Consider the case where the spin is completely about one of the principal axes, say  $\mathbf{e}_1$ . i.e.

$$\omega_1 = \Omega \quad , \quad \omega_2 = \omega_3 = 0 \quad (3.40)$$

This solves Euler's equations (3.33). The question we want to ask is: what happens if the spin varies slightly from this direction? To answer this, consider small perturbations about the spin

$$\omega_1 = \Omega + \eta_1 \quad , \quad \omega_2 = \eta_2 \quad , \quad \omega_3 = \eta_3 \quad (3.41)$$

where  $\eta_a$ ,  $a = 1, 2, 3$  are all taken to be small. Substituting this into Euler's equations and ignoring terms of order  $\eta^2$  and higher, we have

$$\begin{aligned} I_1 \dot{\eta}_1 &= 0 \\ I_2 \dot{\eta}_2 &= \Omega \eta_3 (I_3 - I_1) \end{aligned} \tag{3.42}$$

$$I_3 \dot{\eta}_3 = \Omega \eta_2 (I_1 - I_2) \tag{3.43}$$

We substitute the third equation into the second to find an equation for just one of the perturbations, say  $\eta_2$ ,

$$I_2 \ddot{\eta}_2 = \frac{\Omega^2}{I_3} (I_3 - I_1)(I_1 - I_2) \eta_2 \equiv A \eta_2 \tag{3.44}$$

The fate of the small perturbation depends on the sign of the quantity  $A$ . We have two possibilities

- $A < 0$ : In this case, the disturbance will oscillate around the constant motion.
- $A > 0$ : In this case, the disturbance will grow exponentially.

Examining the definition of  $A$ , we find that the motion is unstable if

$$I_2 < I_1 < I_3 \quad \text{or} \quad I_3 < I_1 < I_2 \tag{3.45}$$

with all other motions stable. In other words, a body will rotate stably about the axis with the largest or the smallest moment of inertia, but not about the intermediate axis. Pick up a tennis racket and try it for yourself!

#### 3.4.4 The Asymmetric Top: Poinsot Construction

The analytic solution for the general motion of an asymmetric top is rather complicated, involving Jacobian elliptic functions. But there's a nice geometrical way of viewing the motion due to Poinsot.

We start by working in the body frame. There are two constants of motion: the kinetic energy  $T$  and the magnitude of the angular momentum  $\mathbf{L}^2$ . In terms of the angular velocity, they are

$$2T = I_1 \omega_1^2 + I_2 \omega_2^2 + I_3 \omega_3^2 \tag{3.46}$$

$$\mathbf{L}^2 = I_1^2 \omega_1^2 + I_2^2 \omega_2^2 + I_3^2 \omega_3^2 \tag{3.47}$$

Each of these equations defines an ellipsoid in  $\boldsymbol{\omega}$  space. The motion of the vector  $\boldsymbol{\omega}$  is constrained to lie on the intersection of these two ellipsoids. The first of these ellipsoids, defined by

$$\frac{I_1}{2T} \omega_1^2 + \frac{I_2}{2T} \omega_2^2 + \frac{I_3}{2T} \omega_3^2 = 1 \quad (3.48)$$

is known as the *inertia ellipsoid* (or, sometimes, the inertia quadric). If we fix the kinetic energy, we can think of this abstract ellipsoid as embedded within the object, rotating with it.

The inertia ellipsoid is drawn in figure 33, where we've chosen  $I_1 > I_2 > I_3$  so that the major axis is  $\omega_3$  and the minor axis is  $\omega_1$ . The lines drawn on the figure are the intersection of the inertia ellipsoid with the other ellipsoid, defined by (3.47), for various values of  $\mathbf{L}^2$ . Since this has the same major and minor axes as the inertia ellipsoid (because  $I_1^2 > I_2^2 > I_3^2$ ), the intersection lines are small circles around the  $\omega_1$  and  $\omega_3$  axes, but two lines passing through the  $\omega_2$  axis. For fixed  $T$  and  $\mathbf{L}^2$ , the vector  $\boldsymbol{\omega}$  moves along one of the intersection lines. This provides a pictorial demonstration of the fact we learnt in the previous subsection: an object will spin in a stable manner around the principal axes with the smallest and largest moments of inertia, but not around the intermediate axis. The path that  $\boldsymbol{\omega}$  traces on the inertia ellipsoid is known as the *polhode curve*. We see from the figure that the polhode curves are always closed, and motion in the body frame is periodic.

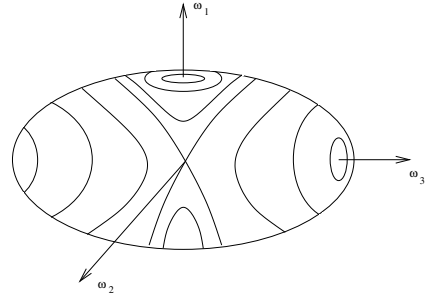
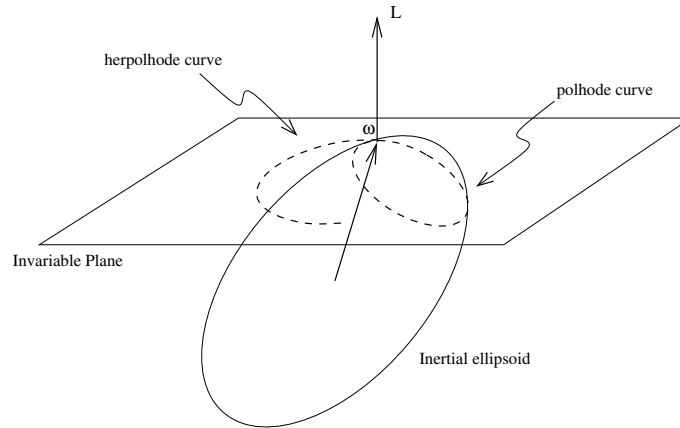

**Figure 33:**

So much for the body frame. What does all this look like in the space frame? The vector  $\mathbf{L}$  is a constant of motion. Since the kinetic energy  $2T = \mathbf{L} \cdot \boldsymbol{\omega}$  is also constant, we learn that  $\boldsymbol{\omega}$  must lie in a fixed plane perpendicular to  $\mathbf{L}$ . This is known as the *invariable plane*. The inertia ellipsoid touches the invariable plane at the point defined by the angular velocity vector  $\boldsymbol{\omega}$ . Moreover, the invariable plane is always tangent to the inertial ellipsoid at the point  $\boldsymbol{\omega}$ . To see this, note that the angular momentum can be written as

$$\mathbf{L} = \nabla_{\boldsymbol{\omega}} T \quad (3.49)$$

where the gradient operator is in  $\boldsymbol{\omega}$  space, i.e.  $\nabla_{\boldsymbol{\omega}} = (\partial/\partial\omega_1, \partial/\partial\omega_2, \partial/\partial\omega_3)$ . But recall that the inertia ellipsoid is defined as a level surface of  $T$ , so equation (3.49) tells



**Figure 34:** The inertia ellipsoid rolling around on the invariable plane, with the polhode and herpolhode curves drawn for a fixed time period.

us that the angular momentum  $\mathbf{L}$  is always perpendicular to the ellipsoid. This, in turn, ensures that the invariable plane is always tangent to the ellipsoid. In summary, the angular velocity traces out two curves: one on the inertia ellipsoid, known as the *polhode curve*, and another on the invariable plane, known as the *herpolhode curve*. The body moves as if it is embedded within the inertia ellipsoid, which rolls around the invariable plane without slipping, with the center of the ellipsoid a constant distance from the plane. The motion is shown in figure 34. Unlike the polhode curve, the herpolhode curve does not necessarily close.

### An Example: The Asteroid Toutatis

Astronomical objects are usually symmetric, but there's an important exception wandering around our solar system, depicted in figure<sup>1</sup> 35. This is the asteroid Toutatis. In September 2004 it passed the earth at a distance of about four times that to the moon. This is (hopefully!) the closest any asteroid will come for the next 60 years. The orbit of Toutatis is thought to be chaotic, which could potentially be bad news for Earth a few centuries from now. As you can see from the picture, its tumbling motion is complicated. It is aperiodic. The pictures show the asteroid at intervals of a day. The angular momentum vector  $\mathbf{L}$  remains fixed and vertical throughout the motion. The angular velocity  $\boldsymbol{\omega}$  traces out the herpolhode curve in the horizontal plane, perpendicular to  $\mathbf{L}$ . The angular momentum vector  $\boldsymbol{\omega}$  also traces out a curve over the asteroid's

---

<sup>1</sup>This picture was created by Scott Hudson of Washington State University and was taken from <http://www.solarviews.com/eng/toutatis.htm> where you can find many interesting facts about the asteroid.



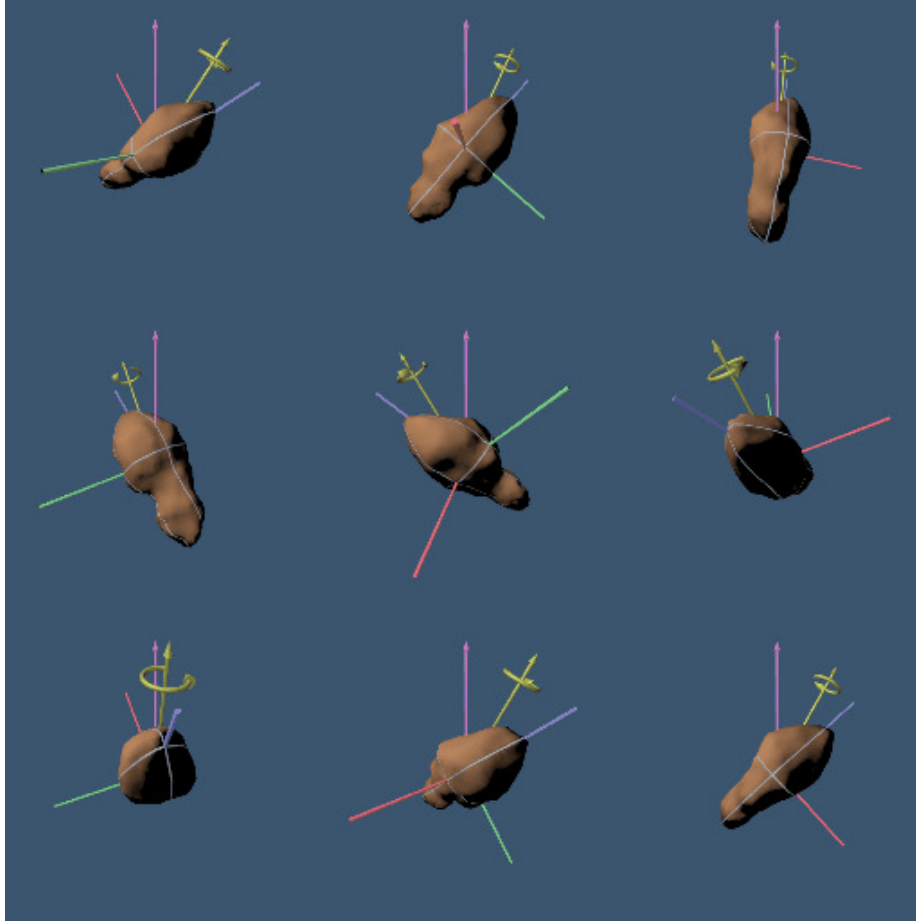

**Figure 35:** By Toutatis! The three principal axes are shown in red, green and blue (without arrows). The angular momentum  $\mathbf{L}$  is the vertical, purple arrow. The angular velocity  $\boldsymbol{\omega}$  is the circled, yellow arrow.

surface: this is the polhode curve. It has a period of 5.4 days which you can observe by noting that  $\boldsymbol{\omega}$  has roughly the same orientation relative to the principal axes every five to six days.

However, there are further effects at play in a real object like Toutatis which is not spinning around a principal axis. Various stresses and strains lead to dissipation. This means that the angular velocity  $\boldsymbol{\omega}$  does not quite follow the polhode curve in Figure 33. Instead it begins close to the major axis  $\omega_3$  and slowly spirals towards the minor axis  $\omega_1$ . This is why we see so few wobbling asteroids.

### 3.5 Euler's Angles

So far we've managed to make quite a lot of progress working just with the angular velocity  $\omega_a$  and we haven't needed to introduce an explicit parametrization of the configuration space  $C$ . But to make further progress we're going to need to do this. We will use a choice due to Euler which often leads to simple solutions.

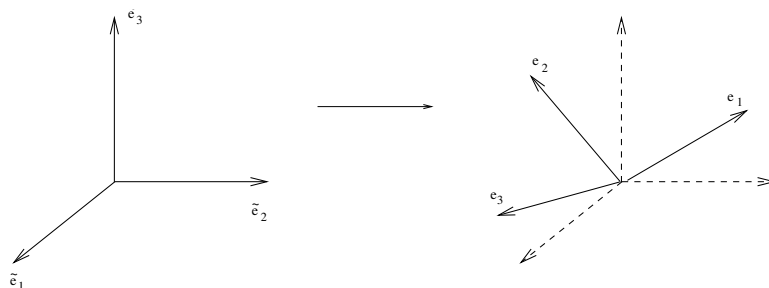

**Figure 36:** The rotation from space frame  $\{\tilde{\mathbf{e}}_a\}$  to body frame  $\{\mathbf{e}_a\}$ .

A general rotation of a set of axis is shown in Figure 36. We'd like to construct a way of parameterizing such a rotation. The way to do this was first described by Euler:

#### Euler's Theorem:

An arbitrary rotation may be expressed as the product of 3 successive rotations about 3 (in general) different axes.

**Proof:** Let  $\{\tilde{\mathbf{e}}_a\}$  be space frame axes. Let  $\{\mathbf{e}_a\}$  be body frame axes. We want to find the rotation  $R$  so that  $\mathbf{e}_a = R_{ab}\tilde{\mathbf{e}}_b$ . We can accomplish this in three steps

$$\{\tilde{\mathbf{e}}_a\} \xrightarrow{R_3(\phi)} \{\mathbf{e}'_a\} \xrightarrow{R_1(\theta)} \{\mathbf{e}''_a\} \xrightarrow{R_3(\psi)} \{\mathbf{e}_a\} \quad (3.50)$$

Let's look at these step in turn.

**Step 1:** Rotate by  $\phi$  about the  $\tilde{\mathbf{e}}_3$  axis. So  $\mathbf{e}'_a = R_3(\phi)_{ab}\tilde{\mathbf{e}}_b$  with

$$R_3(\phi) = \begin{pmatrix} \cos \phi & \sin \phi & 0 \\ -\sin \phi & \cos \phi & 0 \\ 0 & 0 & 1 \end{pmatrix} \quad (3.51)$$

This is shown in Figure 37.

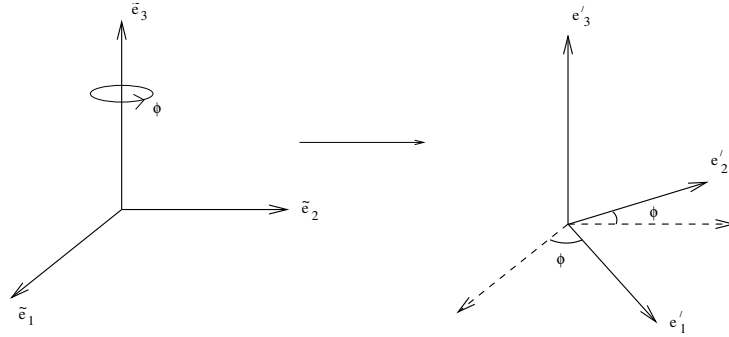
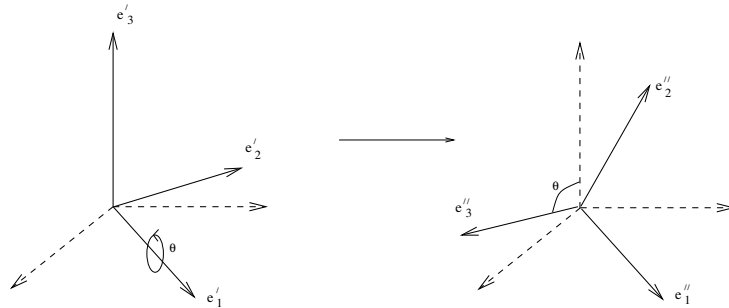

**Figure 37:** Step 1: Rotate around the space-frame axis  $\tilde{\mathbf{e}}_3$ .

**Step 2:** Rotate by  $\theta$  about the *new* axis  $\mathbf{e}'_1$ . This axis  $\mathbf{e}'_1$  is sometimes called the “line of nodes”. We write  $\mathbf{e}''_a = R_1(\theta)_{ab}\mathbf{e}'_b$  with

$$R_1(\theta) = \begin{pmatrix} 1 & 0 & 0 \\ 0 & \cos \theta & \sin \theta \\ 0 & -\sin \theta & \cos \theta \end{pmatrix} \quad (3.52)$$

This is shown in Figure 38

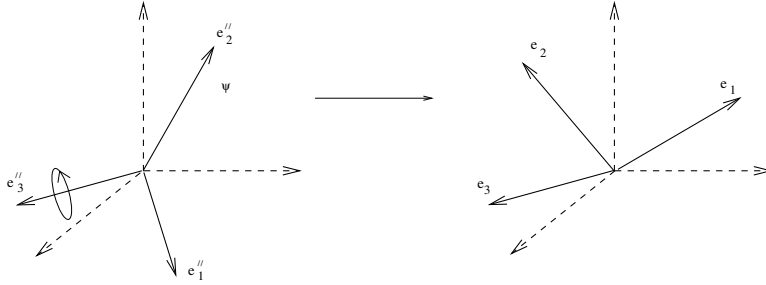

**Figure 38:** Step 2: Rotate around the new axis axis  $\mathbf{e}'_1$ .

**Step 3:** Rotate by  $\psi$  about the *new new* axis  $\mathbf{e}''_3$  so  $\mathbf{e}_a = R_3(\psi)_{ab}\mathbf{e}''_b$  with

$$R_3(\psi) = \begin{pmatrix} \cos \psi & \sin \psi & 0 \\ -\sin \psi & \cos \psi & 0 \\ 0 & 0 & 1 \end{pmatrix} \quad (3.53)$$

This is shown in Figure 39.



**Figure 39:** Step 3: Rotate around the latest axis  $\mathbf{e}''_3$ .

So putting it all together, we have

$$R_{ab}(\phi, \theta, \psi) = [R_3(\psi)R_1(\theta)R_3(\phi)]_{ab} \quad (3.54)$$

□

The angles  $\phi, \theta, \psi$  are the Euler angles. If we write out the matrix  $R(\phi, \theta, \psi)$  longhand, it reads

$$R = \begin{pmatrix} \cos \psi \cos \phi - \cos \theta \sin \phi \sin \psi & \sin \phi \cos \psi + \cos \theta \sin \psi \cos \phi & \sin \theta \sin \psi \\ -\cos \phi \sin \psi - \cos \theta \cos \psi \sin \phi & -\sin \psi \sin \phi + \cos \theta \cos \psi \cos \phi & \sin \theta \cos \psi \\ \sin \theta \sin \phi & -\sin \theta \cos \phi & \cos \theta \end{pmatrix}$$

**Note:** Recall that we may expand a vector  $\mathbf{r}$  either in the body frame  $\mathbf{r} = r_a \mathbf{e}_a$ , or in the space frame  $\mathbf{r} = \tilde{r}_a \tilde{\mathbf{e}}_a$ . The above rotations can be equally well expressed in terms of the coordinates  $r_a$  rather than the basis  $\{\mathbf{e}_a\}$ : we have  $\tilde{r}_b = r_a R_{ab}$ . Be aware that some books choose to describe the Euler angles in terms of the coordinates  $r_a$  which they write in vector form. In some conventions this can lead to an apparent reversal in the ordering of the three rotation matrices.

### 3.5.1 Leonhard Euler (1707-1783)

As is clear from the section headings, the main man for this chapter is Euler, by far the most prolific mathematician of all time. As well as developing the dynamics of rotations, he made huge contributions to the fields of number theory, geometry, topology, analysis and fluid dynamics. For example, the lovely equation  $e^{i\theta} = \cos \theta + i \sin \theta$  is due to Euler. In 1744 he was the first to correctly present a limited example of the calculus of variations (which we saw in section 2.1) although he generously gives credit to a rather botched attempt by his friend Maupertuis in the same year. Euler also invented much of the modern notation of mathematics:  $f(x)$  for a function;  $e$  for exponential;  $\pi$  for, well,  $\pi$  and so on.

Euler was born in Basel, Switzerland and held positions in St Petersburg, Berlin and, after falling out with Frederick the Great, St Petersburg again. He was pretty much absorbed with mathematics day and night. Upon losing the sight in his right eye in his twenties he responded with: “Now I will have less distraction”. Even when he went completely blind later in life, it didn’t slow him down much as he went on to produce over half of his total work. The St Petersburg Academy of Science continued to publish his work for a full 50 years after his death.

### 3.5.2 Angular Velocity

There’s a simple expression for the instantaneous angular velocity  $\boldsymbol{\omega}$  in terms of Euler angles. To derive this, we could simply plug (3.54) into the definition of angular velocity (3.5). But this is tedious, and a little bit of thought about what this means physically will get us there quicker. Consider the motion of a rigid body in an infinitesimal time  $dt$  during which

$$(\psi, \theta, \phi) \rightarrow (\psi + d\psi, \theta + d\theta, \phi + d\phi) \quad (3.55)$$

From the definition of the Euler angles, the angular velocity must be of the form

$$\boldsymbol{\omega} = \dot{\phi} \tilde{\mathbf{e}}_3 + \dot{\theta} \mathbf{e}'_1 + \dot{\psi} \mathbf{e}_3 \quad (3.56)$$

But we can express the first two vectors in terms of the body frame. They are

$$\begin{aligned} \tilde{\mathbf{e}}_3 &= \sin \theta \sin \psi \mathbf{e}_1 + \sin \theta \cos \psi \mathbf{e}_2 + \cos \theta \mathbf{e}_3 \\ \mathbf{e}'_1 &= \cos \psi \mathbf{e}_1 - \sin \psi \mathbf{e}_2 \end{aligned} \quad (3.57)$$

from which we can express  $\boldsymbol{\omega}$  in terms of the Euler angles in the body frame axis

$$\boldsymbol{\omega} = [\dot{\phi} \sin \theta \sin \psi + \dot{\theta} \cos \psi] \mathbf{e}_1 + [\dot{\phi} \sin \theta \cos \psi - \dot{\theta} \sin \psi] \mathbf{e}_2 + [\dot{\psi} + \dot{\phi} \cos \theta] \mathbf{e}_3 \quad (3.58)$$

By playing a similar game, we can also express  $\boldsymbol{\omega}$  in the space frame axis.

### 3.5.3 The Free Symmetric Top Revisited

In section 3.4 we studied the free symmetric top working in the *body frame* and found a constant spin  $\omega_3$  while, as shown in equation (3.37),  $\omega_1$  and  $\omega_2$  precess as

$$(\omega_1, \omega_2) = \omega_0 (\sin \Omega t, \cos \Omega t) \quad \text{with} \quad \Omega = \omega_3 \frac{(I_1 - I_3)}{I_1} \quad (3.59)$$

But what does this look like in the *space frame*? Now that we have parametrised motion in the space frame in terms of Euler angles, we can answer this question. This is simplest if we choose the angular momentum  $\mathbf{L}$  to lie along the  $\tilde{\mathbf{e}}_3$  space-axis. Then because both  $\mathbf{L}$  and its body-frame component  $L_3 = I_3 \omega_3$  are conserved, so too is the angle between them. But this angle is precisely  $\theta$ . We learn that  $\dot{\theta} = 0$ .

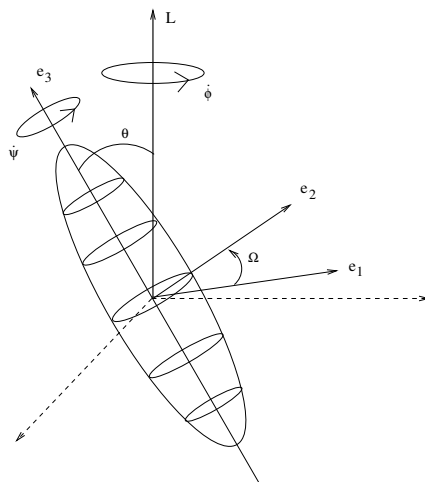

**Figure 40:** Euler angles for the free symmetric top when  $\mathbf{L}$  coincides with  $\tilde{\mathbf{e}}_3$

Next, we use the equations (3.58) to solve for  $\phi(t)$  and  $\psi(t)$ . The solution is given by  $\dot{\psi} = \Omega$ . (This relation also follows by starting at the figure and thinking about how the object spins as it precesses around  $\mathbf{L}$ .) But we know from (3.58) that the expression for  $\omega_3$  (which, remember, is the component of  $\boldsymbol{\omega}$  in the body frame) in terms of Euler angles is  $\omega_3 = \dot{\psi} + \dot{\phi} \cos \theta$  so, substituting for  $\Omega = \dot{\psi}$ , we find the precession frequency

$$\dot{\phi} = \frac{I_3 \omega_3}{I_1 \cos \theta} \quad (3.60)$$

Staring at the figure, the relationship  $\dot{\psi} = \Omega$  may be not be immediately clear.

### An Example: The Wobbling Plate

The physicist Richard Feynman tells the following story:

*“I was in the cafeteria and some guy, fooling around, throws a plate in the air. As the plate went up in the air I saw it wobble, and I noticed the red medallion of Cornell on the plate going around. It was pretty obvious to me that the medallion went around faster than the wobbling.*

*I had nothing to do, so I start figuring out the motion of the rotating plate. I discover that when the angle is very slight, the medallion rotates twice as fast as the wobble rate – two to one. It came out of a complicated equation!*

*I went on to work out equations for wobbles. Then I thought about how the electron orbits start to move in relativity. Then there’s the Dirac equation*

*in electrodynamics. And then quantum electrodynamics. And before I knew it...the whole business that I got the Nobel prize for came from that piddling around with the wobbling plate.”*

Feynman was right about quantum electrodynamics. But what about the plate? We can look at this easily using what we’ve learnt. The spin of the plate is  $\omega_3$ , while the precession, or wobble, rate is  $\dot{\phi}$  which is given in (3.60). To calculate this, we need the moments of inertia for a plate. But we figured this out for the disc in Section 3.2 where we found that  $I_3 = 2I_1$ . We can use this to see that  $\dot{\psi} = -\omega_3$  for this example and so, for slight angles  $\theta$ , have

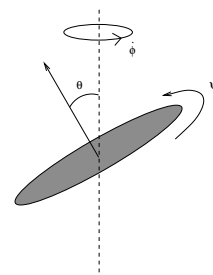

$$\dot{\phi} \approx -2\dot{\psi} \tag{3.61} \quad \text{Figure 41:}$$

Or, in other words, the wobble rate is twice as fast as the spin of the plate. It’s the opposite to how Feynman remembers!

There is another elegant and simple method you can use to see that Feynman was wrong: you can pick up a plate and throw it. It’s hard to see that the wobble to spin ratio is exactly two. But it’s easy to see that it wobbles faster than it spins.

### 3.6 The Heavy Symmetric Top

The “heavy” in the title of this section means that the top is acted upon by gravity. We’ll deal only with a symmetric top, pinned at a point  $P$  which is a distance  $l$  from the centre of mass. This system is drawn in the figure. The principal axes are  $\mathbf{e}_1$ ,  $\mathbf{e}_2$  and  $\mathbf{e}_3$  and we have  $I_1 = I_2$ . From what we have learnt so far, it is easy to write down the Lagrangian:

$$\begin{aligned} L &= \frac{1}{2}I_1(\omega_1^2 + \omega_2^2) + \frac{1}{2}I_3\omega_3^2 - Mgl \cos \theta \\ &= \frac{1}{2}I_1(\dot{\theta}^2 + \sin^2 \theta \dot{\phi}^2) + \frac{1}{2}I_3(\dot{\psi} + \cos \theta \dot{\phi})^2 - Mgl \cos \theta \end{aligned} \tag{3.62}$$

A quick examination of this equation tells us that both  $\psi$  and  $\phi$  are ignorable coordinates. This gives us the constants of motion  $p_\psi$  and  $p_\phi$ , where

$$p_\psi = I_3(\dot{\psi} + \cos \theta \dot{\phi}) = I_3\omega_3 \tag{3.63}$$

This is the angular momentum about the symmetry axis  $\mathbf{e}_3$  of the top. The angular velocity  $\omega_3$  about this axis is simply called the *spin* of the top and, as for the free symmetric top, it is a constant. The other constant of motion is

$$p_\phi = I_1 \sin^2 \theta \dot{\phi} + I_3 \cos \theta (\dot{\psi} + \dot{\phi} \cos \theta) \tag{3.64}$$

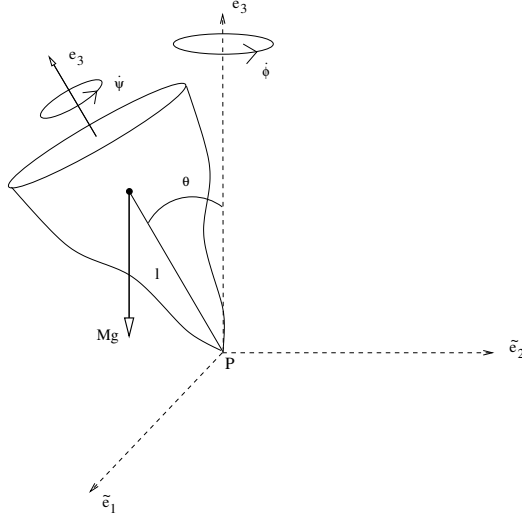

**Figure 42:** The heavy top with its Euler angles

As well as these two conjugate momenta, the total energy  $E$  is also conserved

$$E = T + V = \frac{1}{2}I_1(\dot{\theta}^2 + \dot{\phi}^2 \sin^2 \theta) + \frac{1}{2}I_3\omega_3^2 + Mgl \cos \theta \quad (3.65)$$

To simplify these equations, let's define the two constants

$$a = \frac{I_3\omega_3}{I_1} \quad \text{and} \quad b = \frac{p_\phi}{I_1} \quad (3.66)$$

Then we can write

$$\dot{\phi} = \frac{b - a \cos \theta}{\sin^2 \theta} \quad (3.67)$$

and

$$\dot{\psi} = \frac{I_1 a}{I_3} - \frac{(b - a \cos \theta) \cos \theta}{\sin^2 \theta} \quad (3.68)$$

So if we can solve  $\theta = \theta(t)$  somehow, then we can always integrate these two equations to get  $\phi(t)$  and  $\psi(t)$ . But first we have to figure out what  $\theta$  is doing. To do this, let's define the "reduced energy"  $E' = E - \frac{1}{2}I_3\omega_3^2$ . Then, since  $E$  and  $\omega_3$  are constant, so is  $E'$ . We have

$$E' = \frac{1}{2}I_1\dot{\theta}^2 + V_{\text{eff}}(\theta) \quad (3.69)$$

where the effective potential is

$$V_{\text{eff}}(\theta) = \frac{I_1(b - a \cos \theta)^2}{2 \sin^2 \theta} + Mgl \cos \theta \quad (3.70)$$



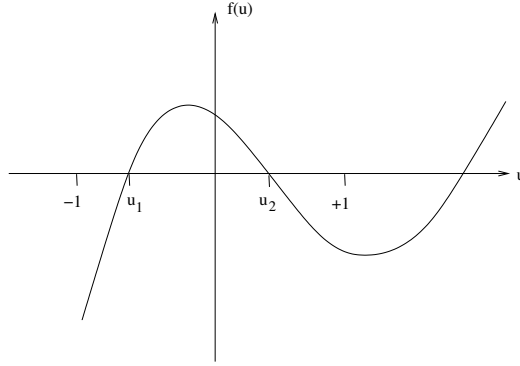

**Figure 43:**

So we've succeeded in getting an equation (3.69) purely in terms of  $\theta$ . To simplify the analysis, let's define the new coordinate

$$u = \cos \theta \quad (3.71)$$

Clearly  $-1 \leq u \leq 1$ . We'll also define two further constants to help put the equations in the most concise form

$$\alpha = \frac{2E'}{I_1} \quad \text{and} \quad \beta = \frac{2Mgl}{I_1} \quad (3.72)$$

With all these redefinitions, the equations of motion (3.67), (3.68) and (3.69) can be written as

$$\dot{u}^2 = (1 - u^2)(\alpha - \beta u) - (b - au)^2 \equiv f(u) \quad (3.73)$$

$$\dot{\phi} = \frac{b - au}{1 - u^2} \quad (3.74)$$

$$\dot{\psi} = \frac{I_1 a}{I_3} - \frac{u(b - au)}{1 - u^2} \quad (3.75)$$

We could take the square root of equation (3.73) and integrate to reduce the problem to quadrature. The resulting integral is known as an "elliptic integral". But, rather than doing this, there's a better way to understand the physics qualitatively.

Note that the function  $f(u)$  defined in (3.73) is a cubic polynomial that behaves as

$$f(u) \rightarrow \begin{cases} +\infty & \text{as } u \rightarrow \infty \\ -\infty & \text{as } u \rightarrow -\infty \end{cases} \quad (3.76)$$

and  $f(\pm 1) = -(b \mp a)^2 \leq 0$ . So if we plot the function  $f(u)$ , it looks like figure 43

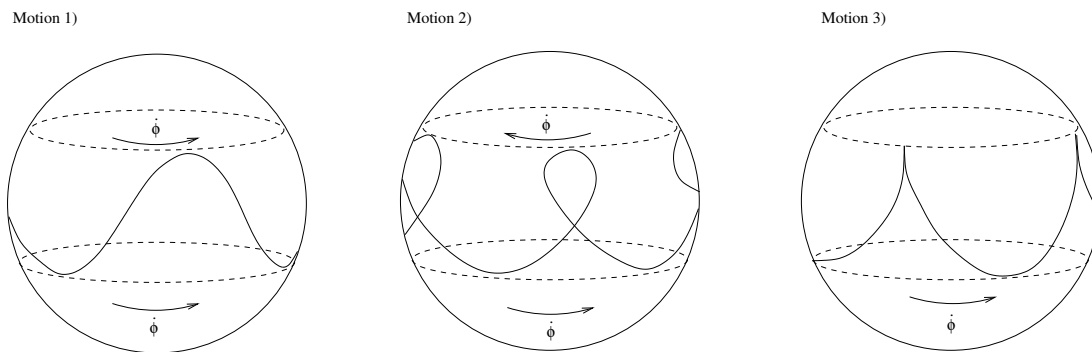

**Figure 44:** The three different types of motion depend on the direction of precession at the extremal points.

The physical range is  $\dot{u}^2 = f(u) > 0$  and  $-1 \leq u \leq 1$  so we find that, like in the spherical pendulum and central force problem, the system is confined to lie between the two roots of  $f(u)$ .

There are three possibilities for the motion depending on the sign of  $\dot{\phi}$  at the two roots  $u = u_1$  and  $u = u_2$  as determined by (3.74). These are

- $\dot{\phi} > 0$  at both  $u = u_1$  and  $u = u_2$
- $\dot{\phi} > 0$  at  $u = u_1$ , but  $\dot{\phi} < 0$  at  $u = u_2$
- $\dot{\phi} > 0$  at  $u = u_1$  and  $\dot{\phi} = 0$  at  $u = u_2$

The different paths of the top corresponding to these three possibilities are shown in figure 44. Motion in  $\phi$  is called *precession* while motion in  $\theta$  is known as *nutation*.

### 3.6.1 Letting the Top Go

The last of these three motions is not as unlikely as it may first appear. Suppose we spin the top and let it go at some angle  $\theta$ . What happens? We have the initial conditions

$$\begin{aligned}
 \dot{\theta}_{t=0} = 0 &\Rightarrow f(u_{t=0}) = 0 \\
 &\Rightarrow u_{t=0} = u_2 \\
 \text{and } \dot{\phi}_{t=0} = 0 &\Rightarrow b - au_{t=0} = 0 \\
 &\Rightarrow u_{t=0} = \frac{b}{a}
 \end{aligned} \tag{3.77}$$

Remember also that the quantity

$$p_\phi = I_1 \dot{\phi} \sin^2 \theta + I_3 \omega_3 \cos \theta = I_3 \omega_3 \cos \theta_{t=0} \quad (3.78)$$

is a constant of motion. We now have enough information to figure out the qualitative motion of the top. Firstly, it starts to fall under the influence of gravity, so  $\theta$  increases. But as the top falls,  $\dot{\phi}$  must turn and increase in order to keep  $p_\phi$  constant. Moreover, we also see that the direction of the precession  $\dot{\phi}$  must be in the same direction as the spin  $\omega_3$  itself. What we get is motion of the third kind.

### 3.6.2 Uniform Precession

Can we make the top precess with bobbing up and down? i.e. with  $\dot{\theta} = 0$  and  $\dot{\phi}$  constant. For this to happen, we would need the function  $f(u)$  to have a single root  $u_0$  lying in the physical range  $-1 \leq u_0 \leq +1$ . This root must satisfy,

$$\begin{aligned} f(u_0) &= (1 - u_0^2)(\alpha - \beta u_0) - (b - a u_0)^2 = 0 \\ \text{and } f'(u_0) &= -2u_0(\alpha - \beta u_0) - \beta(1 - u_0^2) + 2a(b - a u_0) = 0 \end{aligned} \quad (3.79)$$

Combining these, we find  $\frac{1}{2}\beta = a\dot{\phi} - \dot{\phi}^2 u_0$ . Substituting the definitions  $I_1 a = I_3 \omega_3$  and  $\beta = 2Mgl/I_1$  into this expression, we find

$$Mgl = \dot{\phi}(I_3 \omega_3 - I_1 \dot{\phi} \cos \theta_0) \quad (3.80)$$

The interpretation of this equation is as follows: for a fixed value of  $\omega_3$  (the spin of the top) and  $\theta_0$  (the angle at which you let it go), we need to give exactly the right push  $\dot{\phi}$  to make the top spin without bobbing. In fact, since equation (3.80) is quadratic in  $\dot{\phi}$ , there are two frequencies with which the top can precess without bobbing.

Of course, these “slow” and “fast” precessions only exist if equation (3.80) has any solutions at all. Since it is quadratic, this is not guaranteed, but requires

$$\omega_3 > \frac{2}{I_3} \sqrt{Mgl I_1 \cos \theta_0} \quad (3.81)$$

So we see that, for a given  $\theta_0$ , the top has to be spinning fast enough in order to have uniform solutions. What happens if it's not spinning fast enough? Well, the top falls over!

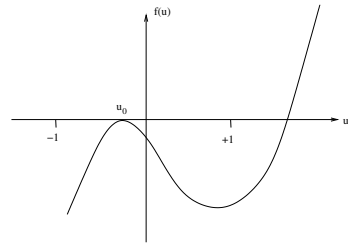

Figure 45:

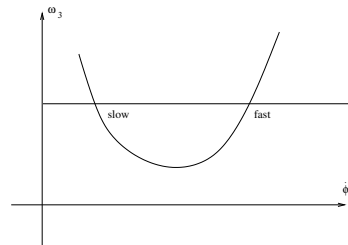
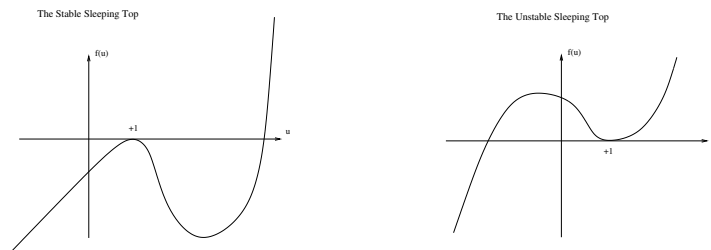

Figure 46:



**Figure 47:** The function  $f(u)$  for the stable and unstable sleeping top.

### 3.6.3 The Sleeping Top

Suppose we start the top spinning in an upright position, with

$$\theta = \dot{\theta} = 0 \quad (3.82)$$

When it spins upright, it is called a *sleeping top*. The question we want to answer is: will it stay there? Or will it fall over? From (3.73), we see that the function  $f(u)$  must have a root at  $\theta = 0$ , or  $u = +1$ :  $f(1) = 0$ . From the definitions (3.66) and (3.72), we can check that  $a = b$  and  $\alpha = \beta$  in this situation and  $f(u)$  actually has a double zero at  $u = +1$ ,

$$f(u) = (1 - u)^2(\alpha(1 + u) - a^2) \quad (3.83)$$

The second root of  $f(u)$  is at  $u_2 = a^2/\alpha - 1$ . There are two possibilities

**1:**  $u_2 > 1$  or  $\omega_3^2 > 4I_1Mgl/I_3^2$ . In this case, the graph of  $f(u)$  is drawn in first in figure 47. This motion is stable: if we perturb the initial conditions slightly, we will perturb the function  $f(u)$  slightly, but the physical condition that we must restrict to the regime  $f(u) > 0$  means that the motion will continue to be trapped near  $u = 1$

**2:**  $u_2 < 1$  or  $\omega_3^2 < 4I_1Mgl/I_3^2$ . In this case, the function  $f(u)$  looks like the second figure of 47. Now the top is unstable; slight changes in the initial condition allow a large excursion.

In practice, the top spins upright until it is slowed by friction to  $I_3\omega_3 = 2\sqrt{I_1Mgl}$ , at which point it starts to fall and precess.

### 3.6.4 The Precession of the Equinox

The Euler angles for the earth are drawn in figure 48. The earth spins at an angle of  $\theta = 23.5^\circ$  to the plane of its orbit around the sun (known as the plane of the elliptic).

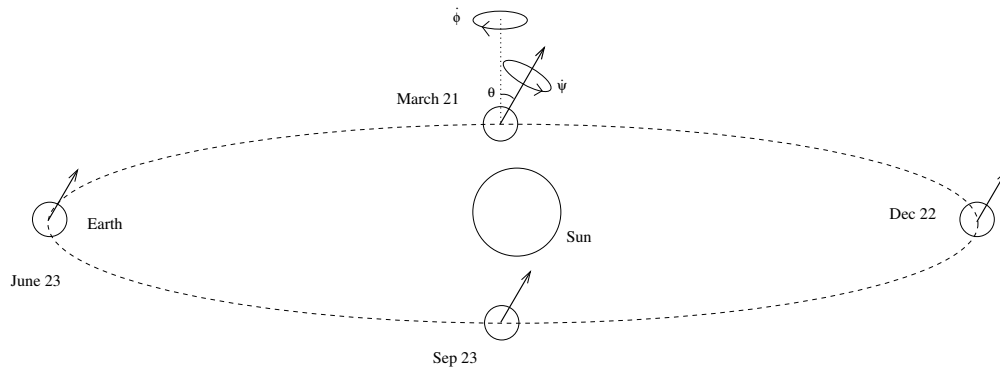

**Figure 48:** The precession of the earth.

The spin of the earth is  $\dot{\psi} = (\text{day})^{-1}$ . This causes the earth to bulge at the equator so it is no longer a sphere, but rather a symmetric top. In turn, this allows the moon and sun to exert a torque on the earth which produces a precession  $\dot{\phi}$ . Physically this means that the direction in which the north pole points traces a circle in the sky and what we currently call the “pole star” will no longer be in several thousand years time. It turns out that this precession is “retrograde” i.e. opposite to the direction of the spin.

One can calculate the precession  $\dot{\phi}$  of the earth due to the moon and sun using the techniques described in the chapter. But the calculation is rather long and we won’t go over it in this course. (See the book by Hand and Finch if you’re interested). Instead, we will use a different technique to calculate the precession of the earth: astrology.<sup>2</sup>

To compute the precession of the earth, the first fact we need to know is that Jesus was born in the age of Pisces. This doesn’t mean that Jesus looked up Pisces in his daily horoscope (while scholars are divided over the exact date of his birth, he seems to exhibit many traits of a typical Capricorn) but rather refers to the patch of the sky in which the sun appears during the first day of spring. Known in astronomical terms as the “vernal equinox”, this day of the year is defined by the property that the sun sits directly above the equator at midday. As the earth precesses, this event takes place at a slightly different point in its orbit each year, with a slightly different backdrop of stars as a result. The astrological age is defined to be the background constellation in which the sun rises during vernal equinox.

---

<sup>2</sup>I learnt about this fact from John Baez’ website where you can find lots of well written explanations of curiosities in mathematical physics: <http://math.ucr.edu/home/baez/README.html>.

It is easy to remember that Jesus was born in the age of Pisces since the fish was used as an early symbol for Christianity. The next fact that we need to know is that we're currently entering the age of Aquarius (which anyone who has seen the musical Hair will know). So we managed to travel backwards one house of the zodiac in 2,000 years. We've got to make it around 12 in total, giving us a precession time of  $2,000 \times 12 = 24,000$  years. The actual value of the precession is 25,700 years. Our calculation is pretty close considering the method!

The earth also undergoes other motion. The value of  $\theta$  varies from  $22.1^\circ$  to  $24.5^\circ$  over a period of 41,000 years, mostly due to the effects of the other planets. These also affect the eccentricity of the orbit over a period of 105,000 years.

### 3.7 The Motion of Deformable Bodies

Take a lively cat. (Not one that's half dead like Schrödinger's). Hold it upside down and drop it. The cat will twist its body and land sprightly on its feet. Yet it doesn't do this by pushing against anything and its angular momentum is zero throughout. If the cat were rigid, such motion would be impossible since a change in orientation for a rigid body necessarily requires non-vanishing angular momentum. But the cat isn't rigid (indeed, it can be checked that dead cats are unable to perform this feat) and bodies that can deform are able to reorient themselves without violating the conservation of angular momentum. In this section we'll describe some of the beautiful mathematics that lies behind this. I should warn you that this material is somewhat more advanced than the motion of rigid bodies. The theory described below was first developed in the late 1980s in order to understand how micro-organisms swim<sup>3</sup>.

#### 3.7.1 Kinematics

We first need to describe the configuration space  $\mathcal{C}$  of a deformable body. We factor out translations by insisting that all bodies have the same center of mass. Then the configuration space  $\mathcal{C}$  is the space of all shapes with some orientation.

Rotations act naturally on the space  $\mathcal{C}$  (they simply rotate each shape). This allows us to define the smaller *shape space*  $\tilde{\mathcal{C}}$  so that any two configurations in  $\mathcal{C}$  which are related by a rotation are identified in  $\tilde{\mathcal{C}}$ . In other words, any two objects that have the same shape, but different orientation, are described by different points in  $\mathcal{C}$ , but the same point in  $\tilde{\mathcal{C}}$ . Mathematically, we say  $\tilde{\mathcal{C}} \cong \mathcal{C}/SO(3)$ .

---

<sup>3</sup>See A. Shapere and F. Wilczek, "Geometry of Self-Propulsion at Low Reynolds Number", J. Fluid Mech. **198** 557 (1989) . This is the same Frank Wilczek who won the 2004 Nobel prize for his work on quark interactions.

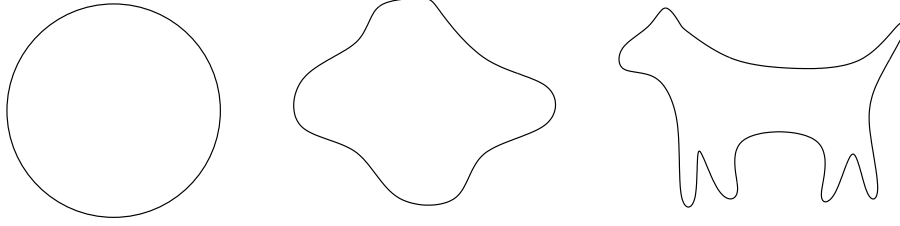

**Figure 49:** Three possible shapes of a deformable object.

We can describe this in more detail for a body consisting of  $N$  point masses, each with position  $\mathbf{r}_i$ . Unlike in section 3.1, we do not require that the distances between particles are fixed, i.e.  $|\mathbf{r}_i - \mathbf{r}_j| \neq \text{constant}$ . (However, there may still be some restrictions on the  $\mathbf{r}_i$ ). The configuration space  $\mathcal{C}$  is the space of all possible configurations  $\mathbf{r}_i$ . For each different shape in  $\mathcal{C}$ , we pick a representative  $\tilde{\mathbf{r}}_i$  with some, fixed orientation. It doesn't matter what representative we choose — just as long as we pick one. These variables  $\tilde{\mathbf{r}}_i$  are coordinates on the space shape  $\tilde{\mathcal{C}}$ . For each  $\mathbf{r}_i \in \mathcal{C}$ , we can always find a rotation matrix  $R \in SO(3)$  such that

$$\mathbf{r}_i = R \tilde{\mathbf{r}}_i \quad (3.84)$$

As in section 3.1, we can always do this to continuous bodies. In this case, the configuration space  $\mathcal{C}$  and the shape space  $\tilde{\mathcal{C}}$  may be infinite dimensional. Examples of different shapes for a continuously deformable body are shown in figure 49.

We want to understand how an object rotates as it changes shape keeping its angular momentum fixed (for example, keeping  $\mathbf{L} = 0$  throughout). The first thing to note is that we can't really talk about the rotation between objects of different shapes. (How would you say that the the third object in figure 49 is rotated with respect to the first or the second?). Instead, we should think of an object moving through a sequence of shapes before returning to its initial shape. We can then ask if there's been a net rotation. As the object moves through its sequence of shapes, the motion is described by a time dependent  $\tilde{\mathbf{r}}_i(t)$ , while the corresponding change through the configuration space is

$$\mathbf{r}_i(t) = R(t) \tilde{\mathbf{r}}_i(t) \quad (3.85)$$

where the  $3 \times 3$  rotation matrix  $R(t)$  describes the necessary rotation to go from our fixed orientation of the shape  $\tilde{\mathbf{r}}$  to the true orientation. As in section 3.1.1, we can define the  $3 \times 3$  anti-symmetric matrix that describes the instantaneous angular velocity of

the object. In fact, it will for once prove more useful to work with the “convective angular velocity” defined around equation (3.10)

$$\Omega = R^{-1} \frac{dR}{dt} \quad (3.86)$$

This angular velocity is non-zero due to the changing shape of the object, rather than the rigid rotation that we saw before. Let’s do a quick change of notation and write coordinates on the shape space  $\tilde{\mathcal{C}}$  as  $x^A$ , with  $A = 1, \dots, 3N$  instead of in vector notation  $\tilde{\mathbf{r}}_i$ , with  $i = 1, \dots, N$ . Then, since  $\Omega$  is linear in time derivatives, we can write

$$\Omega = \Omega_A(x) \dot{x}^A \quad (3.87)$$

The component  $\Omega_A(x)$  is the  $3 \times 3$  angular velocity matrix induced if the shape changes from  $x^A$  to  $x^A + \delta x^A$ . It is independent of time: all the time dependence sits in the  $\dot{x}^A$  factor which tells us how the shape is changing. The upshot is that for each shape  $x \in \tilde{\mathcal{C}}$ , we have a  $3 \times 3$  anti-symmetric matrix  $\Omega_A$  associated to each of the  $A = 1, \dots, 3N$  directions in which the shape can change.

However, there is an ambiguity in defining the angular velocity  $\Omega$ . This comes about because of our arbitrary choice of reference orientation when we picked a representative  $\tilde{\mathbf{r}}_i \in \tilde{\mathcal{C}}$  for each shape. We could quite easily have picked a different orientation,

$$\tilde{\mathbf{r}}_i \rightarrow S(x^A) \tilde{\mathbf{r}}_i \quad (3.88)$$

where  $S(x^A)$  is a rotation that, as the notation suggests, can vary for each shape  $x^A$ . If we pick this new set of representative orientations, then the rotation matrix  $R$  defined in (3.85) changes:  $R(t) \rightarrow R(t) S^{-1}(x^A)$ . Equation (3.86) then tells us that the angular velocity also change as

$$\Omega_A \rightarrow S \Omega_A S^{-1} + S \frac{\partial S^{-1}}{\partial x^A} \quad (3.89)$$

This ambiguity is related to the fact that we can’t define the meaning of rotation between two different shapes. Nonetheless, we will see shortly that when we come to compute the net rotation of the same shape, this ambiguity will disappear, as it must. Objects such as  $\Omega_A$  which suffer an ambiguity of form (3.89) are extremely important in modern physics and geometry. They are known as non-abelian *gauge potentials* to physicists, or as *connections* to mathematicians.



### 3.7.2 Dynamics

So far we've learnt how to describe the angular velocity  $\Omega$  of a deformable object. The next step is to see how to calculate  $\Omega$ . We'll now show that, up to the ambiguity described in (3.89), the angular velocity  $\Omega$  is specified by the requirement that the angular momentum  $\mathbf{L}$  of the object is zero.

$$\begin{aligned}\mathbf{L} &= \sum_i m_i \mathbf{r}_i \times \dot{\mathbf{r}}_i \\ &= \sum_i m_i \left[ (R\tilde{\mathbf{r}}_i) \times (R\dot{\tilde{\mathbf{r}}}_i) + (R\tilde{\mathbf{r}}_i) \times (\dot{R}\tilde{\mathbf{r}}_i) \right] = 0\end{aligned}\quad (3.90)$$

In components this reads

$$L_a = \epsilon_{abc} \sum_i m_i \left[ R_{bd}R_{ce}(\tilde{\mathbf{r}}_i)_d(\dot{\tilde{\mathbf{r}}}_i)_e + R_{bd}\dot{R}_{ce}(\tilde{\mathbf{r}}_i)_d(\tilde{\mathbf{r}}_i)_e \right] = 0\quad (3.91)$$

The vanishing  $\mathbf{L} = 0$  is enough information to determine the following result:

**Claim:** The  $3 \times 3$  angular velocity matrix  $\Omega_{ab} = R_{ac}^{-1}\dot{R}_{cb}$  is given by

$$\Omega_{ab} = \epsilon_{abc} \tilde{I}_{cd}^{-1} \tilde{L}_d\quad (3.92)$$

where  $\tilde{I}$  is the instantaneous inertia tensor of the shape described by  $\tilde{\mathbf{r}}_i$ ,

$$\tilde{I}_{ab} = \sum_i m_i ((\tilde{\mathbf{r}}_i \cdot \tilde{\mathbf{r}}_i) \delta_{ab} - (\tilde{\mathbf{r}}_i)_a (\tilde{\mathbf{r}}_i)_b)\quad (3.93)$$

and  $\tilde{L}_a$  is the apparent angular momentum

$$\tilde{L}_a = \epsilon_{abc} \sum_i m_i (\tilde{\mathbf{r}}_i)_b (\dot{\tilde{\mathbf{r}}}_i)_c\quad (3.94)$$

**Proof:** We start by multiplying  $L_a$  by  $\epsilon_{afg}$ . We need to use the fact that if we multiply two  $\epsilon$ -symbols, we have  $\epsilon_{abc}\epsilon_{afg} = (\delta_{bf}\delta_{cg} - \delta_{bg}\delta_{cf})$ . Then

$$\begin{aligned}\epsilon_{afg}L_a &= \sum_i m_i \left[ R_{fd}R_{ge}(\tilde{\mathbf{r}}_i)_d(\dot{\tilde{\mathbf{r}}}_i)_e - R_{gd}R_{fe}(\tilde{\mathbf{r}}_i)_d(\dot{\tilde{\mathbf{r}}}_i)_e \right. \\ &\quad \left. - R_{gd}\dot{R}_{fe}(\tilde{\mathbf{r}}_i)_d(\tilde{\mathbf{r}}_i)_e + R_{fd}\dot{R}_{ge}(\tilde{\mathbf{r}}_i)_d(\tilde{\mathbf{r}}_i)_e \right] = 0\end{aligned}\quad (3.95)$$

Now multiply by  $R_{fb}R_{gc}$ . Since  $R$  is orthogonal, we know that  $R_{fb}R_{fd} = \delta_{bd}$  which, after contracting a bunch of indices, gives us

$$R_{fb}R_{gc}\epsilon_{afg}L_a = \sum_i m_i \left[ (\tilde{\mathbf{r}}_i)_b (\dot{\tilde{\mathbf{r}}}_i)_c - (\tilde{\mathbf{r}}_i)_c (\dot{\tilde{\mathbf{r}}}_i)_b - \Omega_{bd}(\tilde{\mathbf{r}}_i)_c (\tilde{\mathbf{r}}_i)_d + \Omega_{cd}(\tilde{\mathbf{r}}_i)_b (\tilde{\mathbf{r}}_i)_d \right] = 0$$

This is almost in the form that we want, but the indices aren't quite contracted in the right manner to reproduce (3.92). One can try to play around to get the indices working right, but at this stage it's just as easy to expand out the components explicitly. For example, we can look at

$$\begin{aligned}
\tilde{L}_1 &= \sum_i m_i [(\tilde{\mathbf{r}}_i)_2(\dot{\tilde{\mathbf{r}}}_i)_3 - ((\tilde{\mathbf{r}}_i)_3(\dot{\tilde{\mathbf{r}}}_i)_2)] \\
&= \sum_i m_i [\Omega_{21}(\tilde{\mathbf{r}}_i)_3(\tilde{\mathbf{r}}_i)_1 + \Omega_{23}(\tilde{\mathbf{r}}_i)_3(\tilde{\mathbf{r}}_i)_3 - \Omega_{31}(\tilde{\mathbf{r}}_i)_2(\tilde{\mathbf{r}}_i)_1 - \Omega_{32}(\tilde{\mathbf{r}}_i)_2(\tilde{\mathbf{r}}_i)_2] \\
&= \tilde{I}_{11}\Omega_{23} + \tilde{I}_{12}\Omega_{31} + \tilde{I}_{13}\Omega_{12} = \frac{1}{2} \epsilon_{abc} \tilde{I}_{1a} \Omega_{bc}
\end{aligned} \tag{3.96}$$

where the first equality is the definition of  $\tilde{L}_1$ , while the second equality uses our result above, and the third equality uses the definition of  $\tilde{I}$  given in (3.93). There are two similar equations, which are summarised in the formula

$$\tilde{L}_a = \frac{1}{2} \epsilon_{bcd} \tilde{I}_{ab} \Omega_{cd} \tag{3.97}$$

Multiplying both sides by  $\tilde{I}^{-1}$  gives us precisely the claimed result (3.92). This concludes the proof.  $\square$ .

To summarise: a system with no angular momentum that can twist and turn and change its shape has an angular velocity (3.92) where  $\tilde{\mathbf{r}}_i(t)$  is the path it chooses to take through the space of shapes. This is a nice formula. But what do we do with it? We want to compute the net rotation  $R$  as the body moves through a sequence of shapes and returns to its starting point at a time  $T$  later. This is given by solving (3.86) for  $R$ . The way to do this was described in section 3.1.2. We use *path ordered exponentials*

$$R = \tilde{P} \exp \left( \int_0^T \Omega(t) dt \right) = \tilde{P} \exp \left( \oint \Omega_A dx^A \right) \tag{3.98}$$

The path ordering symbol  $\tilde{P}$  puts all matrices evaluated at later times to the right. (This differs from the ordering in section 3.1.2 where we put later matrices to the left. The difference arises because we're working with the angular velocity  $\Omega = R^{-1}\dot{R}$  instead of the angular velocity  $\omega = \dot{R}R^{-1}$ ). In the second equality above, we've written the exponent as an integral around a closed path in shape space. Here time has dropped out. This tells us an important fact: it doesn't matter how quickly we perform the change of shapes — the net rotation of the object will be the same.

In particle physics language, the integral in (3.98) is called a “Wilson loop”. We can see how the rotation fares under the ambiguity (3.87). After some algebra, you can find that the net rotation  $R$  of an object with shape  $x^A$  is changed by

$$R \rightarrow S(x^A) R S(x^A)^{-1} \tag{3.99}$$

This is as it should be: the  $S^{-1}$  takes the shape back to our initial choice of standard orientation; the matrix  $R$  is the rotation due to the change in shape; finally  $S$  puts us back to the new, standard orientation. So we see that even though the definition of the angular velocity is plagued with ambiguity, when we come to ask physically meaningful questions — such as how much has a shape rotated — the ambiguity disappears. However, if we ask nonsensical questions — such as the rotation between two different shapes — then the ambiguity looms large. In this manner, the theory contains a rather astonishing new ingredient: it lets us know what are the sensible questions to ask! Quantities for which the ambiguity (3.87) vanishes are called *gauge invariant*.

In general, it's quite hard to explicitly compute the integral (3.98). One case where it is possible is for infinitesimal changes of shape. Suppose we start with a particular shape  $x_A^0$ , and move infinitesimally in a loop in shape space:

$$x_A(t) = x_A^0 + \alpha_A(t) \quad (3.100)$$

Then we can Taylor expand our angular velocity components,

$$\Omega_A(x(t)) = \Omega_A(x^0) + \left. \frac{\partial \Omega_A}{\partial x^B} \right|_{x^0} \alpha_B \quad (3.101)$$

Expanding out the rotation matrix (3.98) and taking care with the ordering, one can show that

$$\begin{aligned} R &= 1 + \frac{1}{2} F_{AB} \oint \alpha_A \dot{\alpha}_B dt + \mathcal{O}(\alpha^3) \\ &= 1 + \frac{1}{2} \int F_{AB} dA_{AB} + \mathcal{O}(\alpha^3) \end{aligned} \quad (3.102)$$

where  $F_{AB}$  is anti-symmetric in the shape space indices  $A$  and  $B$ , and is a  $3 \times 3$  matrix (the  $a, b = 1, 2, 3$  indices have been suppressed) given by

$$F_{AB} = \frac{\partial \Omega_A}{\partial x^B} - \frac{\partial \Omega_B}{\partial x^A} + [\Omega_A, \Omega_B] \quad (3.103)$$

It is known as the *field strength* to physicists (or the *curvature* to mathematicians). It is evaluated on the initial shape  $x_A^0$ . The second equality in (3.102) gives the infinitesimal rotation as the integral of the field strength over the area traversed in shape space. This field strength contains all the information one needs to know about the infinitesimal rotations of objects induced by changing their shape.

One of the nicest things about the formalism described above is that it mirrors very closely the mathematics needed to describe the fundamental laws of nature, such as the strong and weak nuclear forces and gravity. They are all described by “non-abelian gauge theories”, with an object known as the gauge potential (analogous to  $\Omega_A$ ) and an associated field strength.